

WOODS

1001378 SUB-FRAME MOUNTING KIT

**Woods Backhoe Model:
BH9000**

mounting to

**John Deere Tractor Models:
5200, 5300, 5400, 5500
5210, 5310, 5410, 5510
With and Without Cab**

equipped with:

**John Deere Loaders
520
540**

**Woods Loaders
1020
1027**

**MANUAL
PART NUMBER
MAN0047**

WOODS®

TO THE DEALER:

Assembly and proper installation of this product is the responsibility of the WOODS dealer. Read manual instructions and safety rules. Make sure all items on the Dealer’s Pre-Delivery and Delivery Check Lists in the Operator’s Manual are completed before releasing equipment to the owner.

The dealer must complete the Warranty Registration included in this manual. Both dealer and customer must sign the registration which certifies that all Dealer Check List items have been completed. The dealer is to return the prepaid postage portion to WOODS, give one copy to the customer, and retain one copy. **Note: Warranty credit is subject to this form being completed and returned.**

TO THE OWNER:

Read this manual before operating your WOODS equipment. The information presented will prepare you to do a better and safer job. Keep this manual handy for ready reference. Require all operators to read this manual carefully and become acquainted with all the adjustment and operating procedures before attempting to operate. Replacement manuals can be obtained from your dealer or, in the United States and Canada, by calling 1-800-319-6637.

The equipment you have purchased has been carefully engineered and manufactured to provide dependable and satisfactory use. Like all mechanical products, it will require cleaning and upkeep. Lubricate the unit as specified. Observe all safety information in this manual and safety decals on the equipment.

For service, your authorized WOODS dealer has trained mechanics, genuine WOODS service parts, and the necessary tools and equipment to handle all your needs.

Use only genuine WOODS service parts. Substitute parts will void the warranty and may not meet standards required for safe and satisfactory operation. Record the model number and serial number of your equipment in the spaces provided:

Model: #1001378 Sub-Frame Mounting Kit Date of Purchase: _____

Serial Number: (see Parts List section for location) _____

Provide this information to your dealer to obtain correct repair parts.

Throughout this manual, the term **IMPORTANT** is used to indicate that failure to observe can cause damage to equipment. The terms **CAUTION**, **WARNING** and **DANGER** are used in conjunction with the Safety-Alert Symbol, (a triangle with an exclamation mark), to indicate the degree of hazard for items of personal safety.



This Safety-Alert Symbol indicates a hazard and means **ATTENTION! BECOME ALERT! YOUR SAFETY IS INVOLVED!**



Indicates an imminently hazardous situation that, if not avoided, will result in death or serious injury



Indicates a potentially hazardous situation that, if not avoided, could result in death or serious injury, and includes hazards that are exposed when guards are removed.



Indicates a potentially hazardous situation that, if not avoided, may result in minor or moderate injury.

IMPORTANT

Indicates that failure to observe can cause damage to equipment.

NOTE

Indicates helpful information.

**WOODS
DUAL
GANNON
ALLOWAY
GILL
GANNONBMP
WAIN ROY
CF
ALITEC**

SAFETY RULES



ATTENTION! BECOME ALERT! YOUR SAFETY IS INVOLVED!



Safety is a primary concern in the design and manufacture of our products. Unfortunately, our efforts to provide safe equipment can be wiped out by an operator's single careless act.

In addition to the design and configuration of equipment, hazard control and accident prevention are dependent upon the awareness, concern, judgement, and proper training of personnel involved in the operation, transport, maintenance and storage of equipment.

It has been said "The best safety device is an informed, careful operator." We ask you to be that kind of operator.

INSTALLATION

- This Sub-Frame Mounting Kit is to be used only for the backhoes and tractors specified in the Sub-Frame Mount Installation section of this manual. Any other use or modification of this mounting kit may result in serious injury or death.
- Hydraulics must be connected as instructed in this manual. Do not substitute parts, modify, or connect in any other way.
- After connecting hoses, check that all control lever positions function as instructed in the Operator's Manual. Do not put into service until control lever and equipment movements are correct.

TRAINING

- Safety instructions are important! Read all attachment and power unit manuals; follow all safety rules and safety decal information. (Replacement manuals are available from dealer or, in the United States and Canada, call 1-800-319-6637.) Failure to follow instructions or safety rules can result in serious injury or death.
- If you do not understand any part of this manual and need assistance, see your dealer.
- Know your controls and how to stop engine and attachment quickly in an emergency.
- Keep hands and body away from pressurized lines. Use paper or cardboard, not hands or other body parts to check for leaks. Wear safety goggles. Hydraulic fluid under pressure can easily penetrate skin and will cause serious injury or death.
- Make sure that all operating and service personnel know that if hydraulic fluid penetrates skin, it must be surgically removed as soon as possible by a doctor familiar with this form of injury or gan-

grene, serious injury, or death will result. **CONTACT A PHYSICIAN IMMEDIATELY IF FLUID ENTERS SKIN OR EYES. DO NOT DELAY.**

- Never allow children or untrained persons to operate equipment.

PREPARATION

- Check that all hardware is properly installed. Always tighten to torque chart specifications unless instructed otherwise in this manual.
- Air in hydraulic systems can cause erratic operation and allow loads or equipment components to drop unexpectedly. When connecting equipment or hoses or performing any hydraulic maintenance, purge any air in hydraulic system by operating all hydraulic functions several times. Do this before putting into service or allowing anyone to approach the equipment.
- After connecting hoses, check that all control lever positions function as instructed in the Operator's Manual. Do not put into service until control lever and equipment movements are correct.
- Protective hose sleeves must cover all hydraulic hoses and be secured onto metal hose fittings. Replace hoses or sleeves if damaged or if protective sleeve cannot be properly positioned or secured.
- Make sure all hydraulic hoses, fittings, and valves are in good condition and not leaking before starting power unit or using equipment. Check and route hoses carefully to prevent damage. Hoses must not be twisted, bent sharply, kinked, frayed, pinched, or come into contact with any moving parts. Operate moveable components through full operational range to check clearances. Replace any damaged hoses immediately.
- Always wear relatively tight and belted clothing to avoid entanglement in moving parts. Wear sturdy, rough-soled work shoes and protective equipment for eyes, hair, hands, hearing, and head.
- Make sure attachment is properly secured, adjusted, and in good operating condition.
- The sub-frame mount is designed to provide secure mounting and adequate operator clearance when properly installed. Check clearance dimensions shown in figure 1 to be sure you have installed sub-frame correctly. Follow all mounting instructions in this manual. Do not operate backhoe unless there is adequate clearance. Failure to

SAFETY RULES



ATTENTION! BECOME ALERT! YOUR SAFETY IS INVOLVED!



check and comply with these instructions may result in serious injury or death.

- Remove seat and upper support assembly before installing or removing backhoe from tractor. Failure to comply may result in equipment failure and/or personal injury.
- Always use the special heavy-duty top link (provided with backhoe) and the OEM high-strength top link pin (provided with tractor) to mount top link to tractor. Use a 1" x 5" grade 5 bolt to mount top link to backhoe.
- If tractor is equipped with draft sensing control, set control to "HEAVY" (minimum sensitivity) position.
- On tractors equipped with optional "Draft Control Hitch," you must install the "Draft Lockout" (provided in sub-frame kit) into position as shown. Failure to install the "Draft Lockout" will allow upper hitch to move during backhoe operation and could result in operator injury.
- Make sure all safety decals are installed. Replace if damaged. (See Safety Decals section for location.)
- A minimum 25% of tractor and equipment weight must be on the tractor front wheels when attachments are in transport position. Without this weight, tractor could tip over, causing personal injury or death. The weight may be attained with a loader, front wheel weights, ballast in tires, or front tractor weights. Weigh the tractor and equipment. Do not estimate.

OPERATION

- Do not allow bystanders in the area when operating, attaching, removing, assembling, or servicing equipment.
- Before operating, make sure stabilizer pads are lowered firmly to the ground. Stabilizer arms provide support for the backhoe and support for the backhoe mounting brackets.
- Do not operate equipment while under the influence of alcohol or drugs.
- Always comply with all state and local lighting and marking requirements.
- Do not allow riders. Do not lift or carry anybody on the power unit or attachments.
- The only time the backhoe may be operated from a position other than the operator seat is during backhoe attachment and removal. Operator must

- Read Sub-Frame Mounting Kit Manual instructions on attaching and removing backhoe and use extreme care
- Always stand between rear tire and backhoe stabilizer arms or along side of tractor to avoid being trapped should the boom swing control be accidentally activated.

- Never leave equipment unattended with engine running or with bucket in raised position. Always engage swing and boom transport locks, relieve system pressure by operating controls, and remove ignition key before leaving equipment.

MAINTENANCE

- Refer to backhoe manual and follow all maintenance safety rules and instructions.
- Do not modify or alter or permit anyone else to modify or alter the equipment or any of its components in any way.
- Your dealer can supply original equipment hydraulic accessories and repair parts. Substitute parts may not meet original equipment specifications and may be dangerous.
- Always wear relatively tight and belted clothing to avoid entanglement in moving parts. Wear sturdy, rough-soled work shoes and protective equipment for eyes, hair, hands, hearing, and head.
- Do not allow bystanders in the area when operating, attaching, removing, assembling, or servicing equipment.
- Make sure attachment is properly secured, adjusted, and in good operating condition.
- Keep all persons away from operator control area while performing adjustments, service, or maintenance.
- Before working on backhoe, extend boom and dipperstick and place bucket on ground. Make sure that all system pressure has been relieved by operating controls before performing maintenance or service or before disconnecting any hydraulic lines.
- Tighten all bolts, nuts and screws to torque chart specifications. Check that all cotter pins are installed securely to ensure equipment is in a safe condition before putting unit into service.
- Make sure all safety decals are installed. Replace if damaged. (See Safety Decals section for location.)

BACKHOE SUB-FRAME INSTALLATION

Safety is a primary concern in the design and manufacture of our products. Unfortunately, our efforts to provide safe equipment can be wiped out by an operator's single careless act.

In addition to the design and configuration of equipment, hazard control and accident prevention are dependent upon the awareness, concern, judgement, and proper training of personnel involved in the operation, transport, maintenance and storage of equipment.

It has been said "The best safety device is an informed, careful operator." We ask you to be that kind of operator.

DANGER

■ The sub-frame mount is designed to provide secure mounting and adequate operator clearance when properly installed. Check clearance dimensions shown in figure 1 to be sure you have installed sub-frame correctly. Follow all mounting instructions in this manual. Do not operate backhoe unless there is adequate clearance. Failure to check and comply with these instructions may result in serious injury or death.

■ The only time the backhoe may be operated from a position other than the operator seat is during backhoe attachment and removal. Operator must

- Read Operator's Manual instructions on attaching and removing backhoe and use extreme care
- Engage swing lock to prevent boom rotation
- Always stand rearward of backhoe stabilizer arms or along side of tractor to avoid being trapped should the boom swing control be accidentally activated.

WARNING

■ Only use #1001378 Sub-Frame Mounting Kit for mounting Woods BH9000 backhoe on John Deere 5200, 5300, 5400, 5210, 5310, 5410 and 5510 tractors equipped with either Woods model 1020/1027 loaders or John Deere 520 and 540 loaders. Any other use or modification of this mounting kit may result in serious injury or death.

■ Safety instructions are important! Read all attachment and power unit manuals; follow all safety rules and safety decal information. (Replacement manuals are available from dealer or, in the United States and Canada, call 1-800-319-6637.) Failure to follow instructions or safety rules can result in serious injury or death.

■ Keep all persons away from operator control area while performing adjustments, service, or maintenance.

■ Before working on backhoe, extend boom and dipperstick and place bucket on ground. Make sure that all system pressure has been relieved by operating controls before performing maintenance or service or before disconnecting any hydraulic lines.

■ A minimum 25% of tractor and equipment weight must be on the tractor front wheels when attachments are in transport position. Without this weight, tractor could tip over, causing personal injury or death. The weight may be attained with a loader, front wheel weights, ballast in tires, or front tractor weights. Weigh the tractor and equipment. Do not estimate.

■ Make sure all hydraulic hoses, fittings, and valves are in good condition and not leaking before starting power unit or using equipment. Check and route hoses carefully to prevent damage. Hoses must not be twisted, bent sharply, kinked, frayed, pinched, or come into contact with any moving parts. Operate moveable components through full operational range to check clearances. Replace any damaged hoses immediately.

SUB-FRAME INSTALLATION Cont'd

CAUTION

- If you do not understand any part of this manual and need assistance, see your dealer.
- Always wear relatively tight and belted clothing to avoid entanglement in moving parts. Wear sturdy, rough-soled work shoes and protective equipment for eyes, hair, hands, hearing, and head.

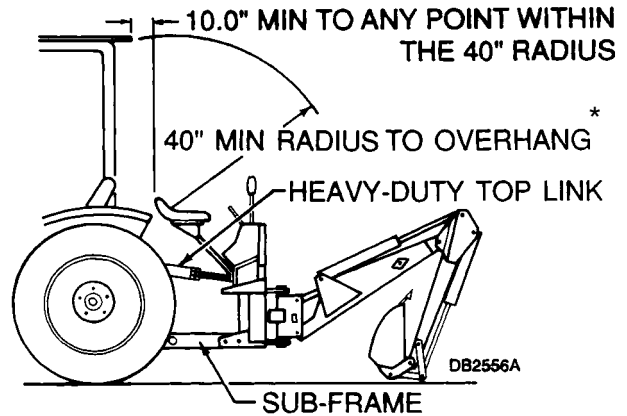

* Operator's seat must be located in the lowest and most forward position to obtain 40" minimum radius.

Figure 1 Sub-Frame Clearance

TRACTOR PREPARATION

1. Refer to the WOODS BH9000 Backhoe Operator's Manual for backhoe assembly instructions.

NOTE: For installing this sub-frame, reference to right, left, forward and rearward directions are determined from the operator's position in the tractor seat.

2. Remove the tractor top link, 3-point lower lift arms, and anti-sway links.

3. Remove three bolts from both lower 3-point arm pivot pins, leave pins in place (Figure 2).

4. **NOTE:** Leave all hardware loose until sub-frame weldment has been fit up.



Figure 2 Remove hardware from pivot pins

SUB-FRAME INSTALLATION Cont'd

Install Front Support

1. Remove cap screw (4) and hose holder (5) from bottom of tractor chassis.
2. Install front hanger (1) to bottom of tractor chassis and secure using four cap screws (2) and flat washers (3) as shown in Figure 3.
3. Install cap screw (4), hose holder (5) and hex lock nut (6) to left front corner of front support.

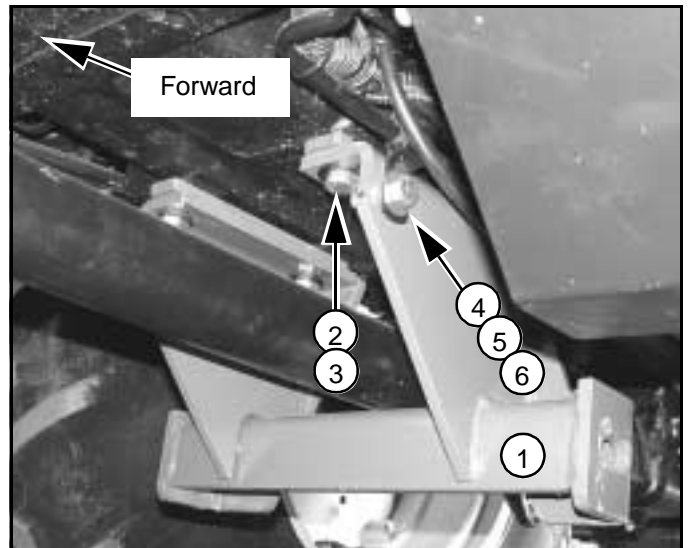

Figure 3 Front Support Installed

- | | | |
|----|---------|--------------------------------|
| 1. | 1001383 | Front Support |
| 2. | 33125 | M14 x 2.0P x 50mm Cap screw |
| 3. | 46070 | 9/16 Flat washer, hardened |
| 4. | ----- | M14 x 2.0P Cap screw (Tractor) |
| 5. | ----- | Hose holder (Tractor) |
| 6. | 307825 | M14 x 2.0P Hex nut |

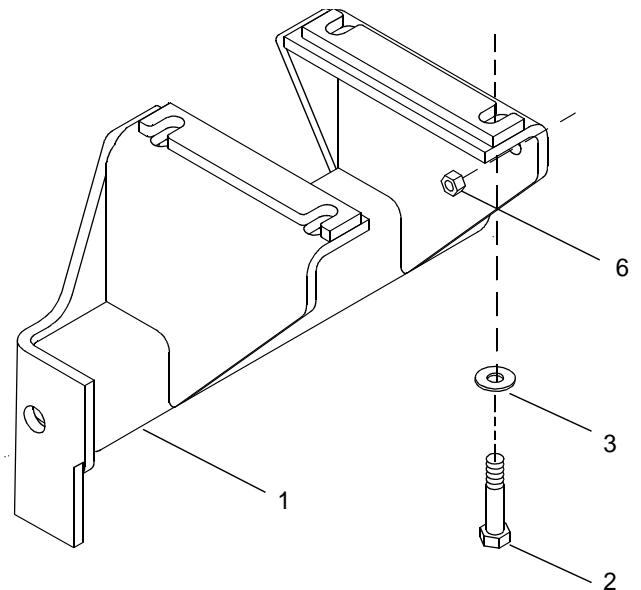

Figure 4 Front Support Installation

SUB-FRAME INSTALLATION Cont'd

Install Right and Left Rear Supports Right Rear Support #1001380 Left Rear Support #100381

1. Install right rear support by inserting cap screw (1) and flat washers (2) into position as shown in Figure 6.

NOTE: Install flat washers between rear support and pivot pin and on outside at head of cap screw as shown in Figure 5.

2. Install cap screw (3) and flat washer (2) in front hole(Figure 6). Only use one flat washer on outside at head of cap screw.

3. Install remaining two cap screws (1) and four flat washers (2) into position around pivot pin. Install flat washers both inside and outside of rear support.

4. Install two cap screws (4) and flat washers (5) into bottom of tractor chassis as shown in Figure 7

5. Install left rear support, following steps 1-5.

Install Cross Member #1001387

6. Install cross member between right and left rear supports using four cap screws (3), flat washers (2) and hex nuts (6) as shown in Figure 7.

1. 1001575 M14 x 2.0P x 55mm Cap screw
2. 46070 9/16 Flat washer, hardened
3. 33125 M14 X 2.0p X 50 mm Cap screw
4. 30743 M16 x 2.0P x 45mm Cap screw
5. 57817 5/8 Flat washer, hardened
6. 307825 M14 x 2.0P Hex nut

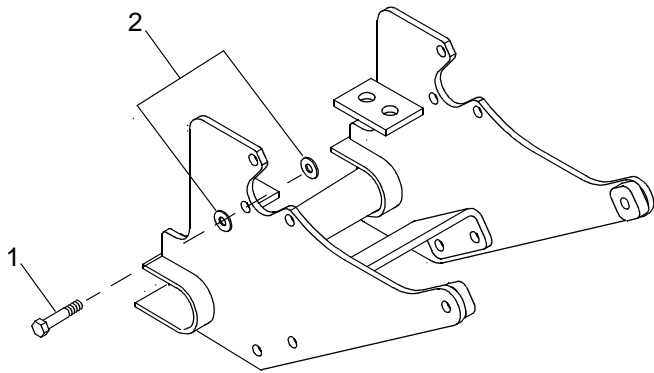

Figure 5 Flat Washer Installation on Rear Support

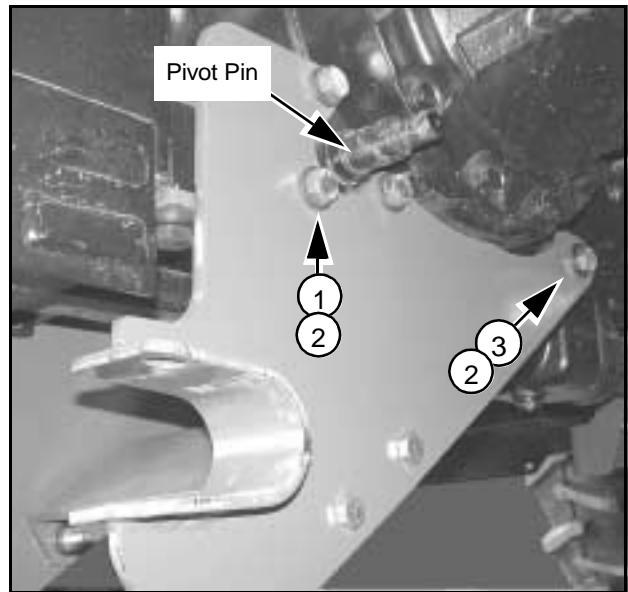

Figure 6 Right Rear Support Installed

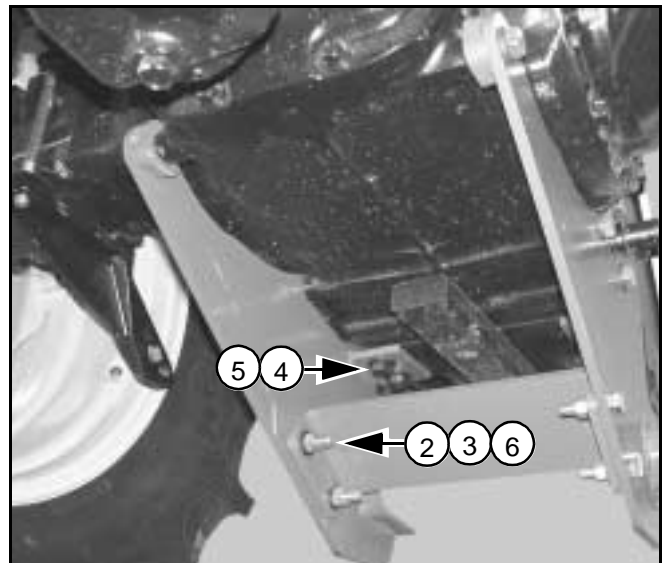

Figure 7 Rear Supports & Cross Member Installed

SUB-FRAME INSTALLATION Cont'd

Sub-Frame Fit-Up

1. Center sub-frame under tractor.
2. Insert cross tube of sub-frame into channel of rear support as shown in Figure 8.
3. Install clevis pins (1) and hair pins (2) to secure sub-frame and rear supports as shown in Figure 8.

1. 37827 Clevis pin .75 x 3.14
2. 2688 Hair pin 5/32

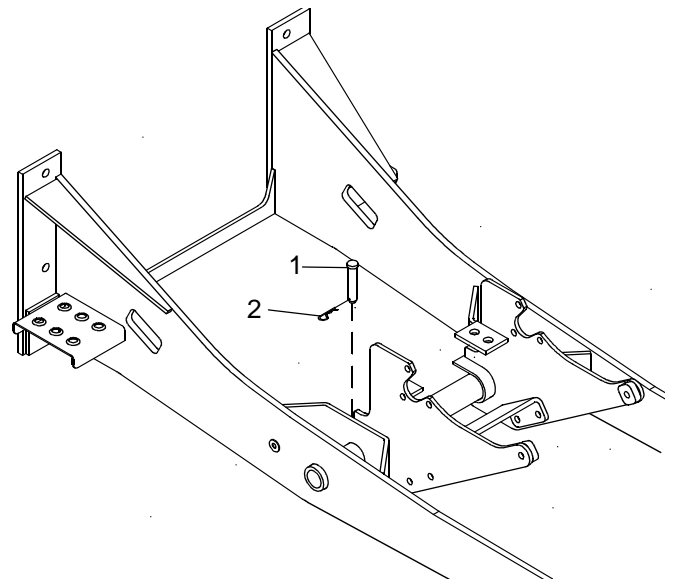

Figure 8 Clevis Pins Installed

4. Rotate sub-frame up until locating lugs are positioned on the outside of front support.
5. Align holes and install bent pin (3) and klik pin 4 as shown in Figure 9.
6. Once sub-frame is secured into position, tighten all hardware to torque specifications.
7. Remove sub-frame from tractor.

3. 54088 Bent pin
4. 62043 1/4 x 1-3/4 Klik pin

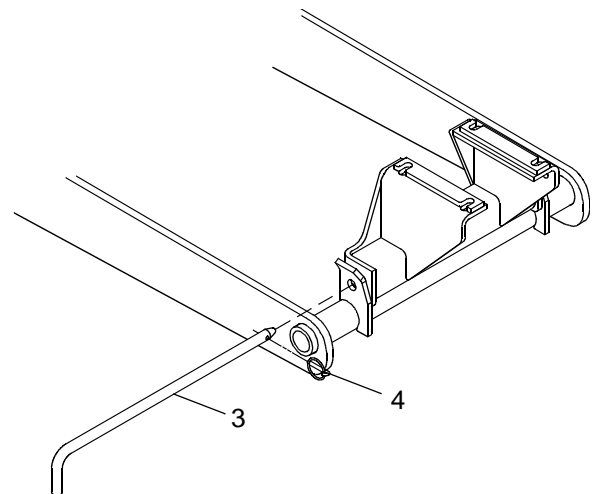

Figure 9 Bent Pin Installation

TORQUE SPECIFICATIONS

Cap Screw	Qty	Wrench	
		Size	Required Torque
M14 x 2.0 x 50mm	10	21mm	80 lbs.-ft.(109 N-m)
M14 x 2.0 x 55mm	6	21mm	80 lbs.-ft.(109 N-m)
M16 x 2.0 x 45mm	4	24mm	125 lbs.-ft.(169 N-m)

SUB-FRAME INSTALLATION Cont'd

Attach Sub-Frame to Backhoe

1. Align six holes on the backhoe with holes on sub-frame.
2. Secure with six cap screws, flat washers, and hex nuts as shown. Tighten according to specifications given below.

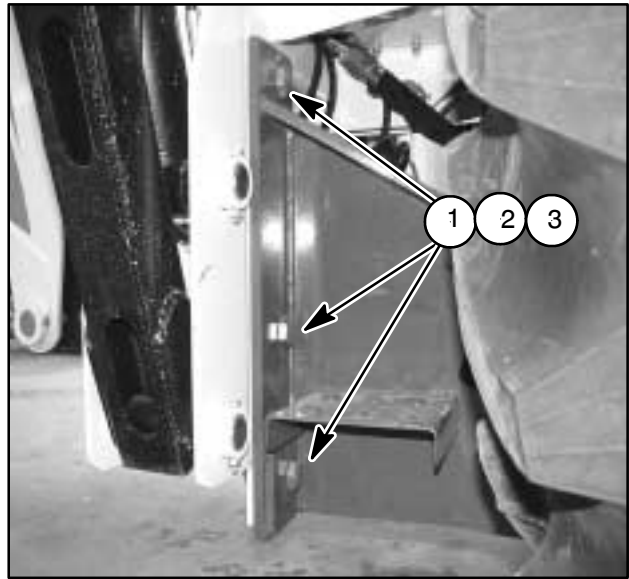
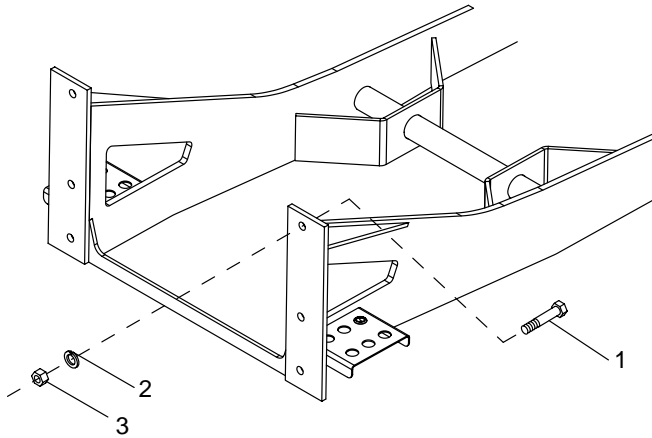

Figure 10 Sub-Frame Installed to Backhoe

1. 13759 3/4 NC x 2-1/4 Cap screw
2. 57798 3/4 Flat washer, hardened
3. 1450 3/4 Hex nut

TORQUE SPECIFICATIONS

Cap Screw	Qty	Wrench Size	Required Torque
3/4 NC x 2-1/4	6	1-1/8"	297 lbs.-ft. (403 N-m)

PUMP KIT INSTALLATION

Install Pump Kit #9504

NOTE: For complete information on pump kit installation, consult the Woods BH9000 backhoe operators manual #38638.

NOTE: Discard pump mounting bracket provided in pump kit #9504.

1. Attach pump mounting bracket #54084 supplied with sub-frame mounting kit #1001378, to pump assembly (2) using cap screw (3) and lock nut (4) as shown in Figure 11. Torque hardware to 85 lbs.-ft.

2. Attach pump mounting bracket with bent leg toward tractor as shown in Figure 12.

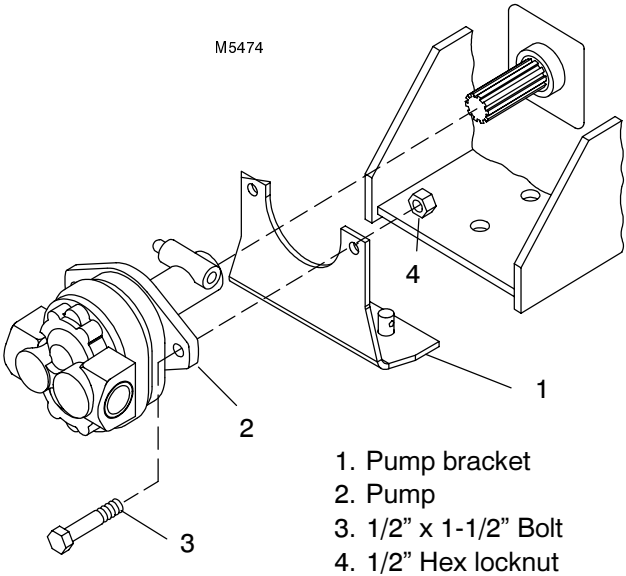

- 1. 54084 Pump mounting bracket
- 2. ----- Pump assembly with adapter
- 3. 3379 1/2 NC x 1-1/2 Cap screw
- 4. 765 1/2 NC Hex lock nut

Figure 11 Pump Bracket Installation



Figure 12 Pump and Bracket Installed

Connect Hydraulic System

 **WARNING**

■ **Keep hands and body away from pressurized lines. Use paper or cardboard, not hands or other body parts to check for leaks. Wear safety goggles. Hydraulic fluid under pressure can easily penetrate skin and will cause serious injury or death.**

■ **Make sure that all operating and service personnel know that if hydraulic fluid penetrates skin, it must be surgically removed as soon as possible by a doctor familiar with this form of injury or gangrene, serious injury, or death will result. CONTACT A PHYSICIAN IMMEDIATELY IF FLUID ENTERS SKIN OR EYES. DO NOT DELAY.**

■ **Make sure all hydraulic hoses, fittings, and valves are in good condition and not leaking before starting power unit or using equipment. Check and route hoses carefully to prevent damage. Hoses must not be twisted, bent sharply, kinked, frayed, pinched, or come into contact with any moving parts. Operate moveable components through full operational range to check clearances. Replace any damaged hoses immediately.**

1. Couple the backhoe hydraulic pump to the tractor PTO, if equipped.

2. Insert the pump bracket between the tractor drawbar support to prevent pump rotation. Engage the pump PTO coupler pin firmly in the tractor PTO spline groove.

3. Check all hydraulic fittings and lines to be sure they are tight and free of kinks or twists.

4. Make sure backhoe {PTO driven hydraulic system is full (approximately 10 US gallons). Check the tractor hydraulic reservoir and service if necessary.

NOTE: See the BH9000 backhoe operator manual for hydraulic oil recommendations. Do not mix hydraulic fluid types.

5. Be sure the backhoe controls are centered in the neutral position and the backhoe hydraulic pump is securely mounted to the tractor.

6. With the tractor PTO and transmission in neutral, start the engine and run at low idle.

7. Smoothly engage the PTO pump to provide backhoe hydraulics.

NOTE: Very little engine power is required to operate the hydraulic system in this mode. Should the engine pull down excessively, check the plumbing hook-up for reversed lines or a control lever stuck in an operating position.

SUB-FRAME & BACKHOE INSTALLATION TO TRACTOR

Mount Sub-Frame & Backhoe to Tractor

DANGER

■ The sub-frame mount is designed to provide secure mounting and adequate operator clearance when properly installed. Check clearance dimensions shown in figure 1 to be sure you have installed sub-frame correctly. Follow all mounting instructions in this manual. Do not operate backhoe unless there is adequate clearance. Failure to check and comply with these instructions may result in serious injury or death.

■ The only time the backhoe may be operated from a position other than the operator seat is during backhoe attachment and removal. Operator must

- Read Operator's Manual instructions on attaching and removing backhoe and use extreme care
- Engage swing lock to prevent boom rotation
- Always stand rearward of backhoe stabilizer arms or along side of tractor to avoid being trapped should the boom swing control be accidentally activated.

WARNING

■ Remove seat and upper support assembly before installing or removing backhoe from tractor. Failure to comply may result in equipment failure and/or personal injury.

1. Remove the backhoe seat assembly.
2. Place sub-frame flat on a hard level surface.
3. Back tractor over the sub-frame and center between the tractor rear tires. Position tractor so that the hydraulic system can be connected
4. Use the backhoe hydraulics to maneuver the sub-frame into position for hook-up. Use care in this procedure to avoid being trapped between tractor and backhoe or between backhoe parts.
5. Raise sub-frame up by lowering stabilizers and boom section until cross tube is level with rear mounting bracket channel.
6. Shut off tractor. Roll tractor back so tube slides into channel.
7. Fasten sub-frame in place by placing clevis pins into channel holes and secure with safety pins.
8. With the tractor engine off, relieve pressure in the backhoe boom to raise sub-frame into front hanger.
9. Install bent pin and klik pin.

SUB-FRAME & BACKHOE to TRACTOR Cont.

Attach Top Link

1. Assemble inner top link (2), 1" hex nut (1), and outer top link (3).
2. Attach top link (inner link end) to backhoe mainframe with 1.0 x 4.5 clevis pin (4) and klik pins (5) as shown in Figure 14.
3. Adjust top link as necessary to fit between the backhoe mainframe and tractor top link bracket.
4. Attach outer link end to tractor top link bracket using original tractor top link pin as shown in Figure 15.
5. Tighten 1" hex nut (1).

- | | | |
|----|---------|----------------------|
| 1. | 3132 | 1" Hex nut |
| 2. | 38645 | Inner Top Link |
| 3. | 1001579 | Outer Top Link |
| 4. | 45087 | 1.0 x 4.5 Clevis Pin |
| 5. | 62043 | 1/4 x 1-3/4 Klik Pin |
| 6. | ----- | Tractor Klik Pin |
| 7. | ----- | Tractor Top Link Pin |

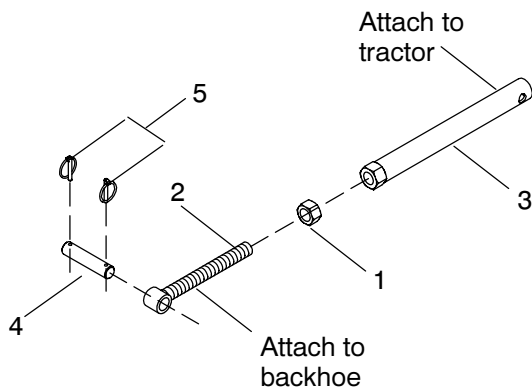

Figure 13 Top Link Assembly

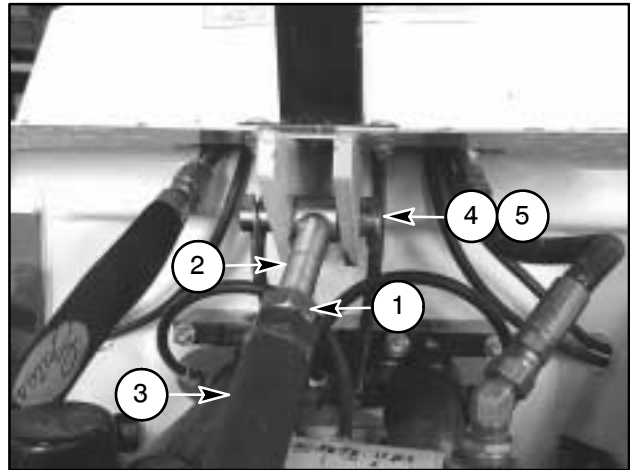

Figure 14 Top Link to Backhoe Installation

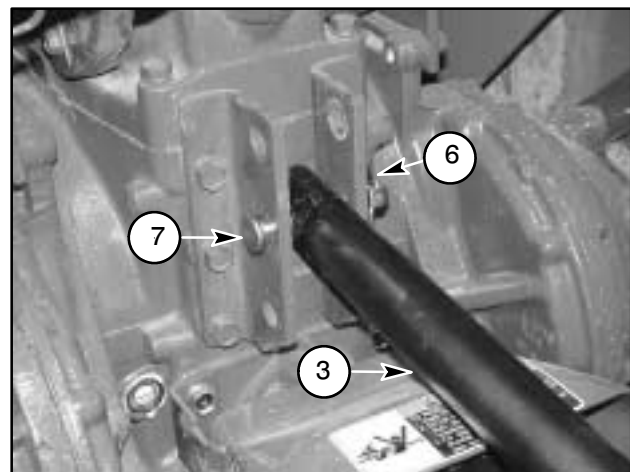

Figure 15 Top Link to Tractor Installation (Typical Installation)

Remove Backhoe With Sub-Frame

DANGER

- **The only time the backhoe may be operated from a position other than the operator seat is during backhoe attachment and removal. Operator must**
 - **Read Operator's Manual instructions on attaching and removing backhoe and use extreme care**
 - **Engage swing lock to prevent boom rotation**
 - **Always stand rearward of backhoe stabilizer arms or along side of tractor to avoid being trapped should the boom swing control be accidentally activated.**

WARNING

- **Remove seat and upper support assembly before installing or removing backhoe from tractor. Failure to comply may result in equipment failure and/or personal injury.**

1. On a hard level surface, center the backhoe boom.
 2. Extend boom and dipperstick so that dipperstick is perpendicular the bucket all the way towards the operator (90°) to the ground.
 3. Rest bucket on the ground and lower stabilizers to take backhoe weight off tractor.
 4. Turn off engine, set brakes, and remove key before leaving tractor seat.
 5. Remove the seat assembly.
 6. Remove top link pins and top link assembly.
 7. Remove retaining pins from front sub-frame bracket and clevis pins from rear hanger bracket.
 8. Roll the tractor far enough to release the sub-frame from the brackets.
 9. Start engine and raise the rear of the backhoe with stabilizers to pivot the front of the sub-frame down.
 10. Place blocks under backhoe mainframe and raise stabilizers to lower backhoe onto the blocks.
- NOTE:** The front of the sub-frame must be low enough to clear the tractor chassis for removal.
11. Turn off engine, set brakes, and remove key before leaving tractor seat.
 12. Disengage the tractor PTO and remove the backhoe hydraulic pump from the PTO shaft, if equipped, or disengage the tractor hydraulic circuit and disconnect the hydraulic quick couplers.
 13. Make sure backhoe and sub-frame clear the tractor chassis and drive the tractor away.

SUB-FRAME & BACKHOE to TRACTOR Cont.

Store Hydraulic Pump

1. Disconnect pump (1) from tractor PTO.
2. Rotate pump and insert pin on pump mounting bracket through outside hole on foot rest as shown in Figure 16.
3. Secure to foot rest (3) with klik pin (2).

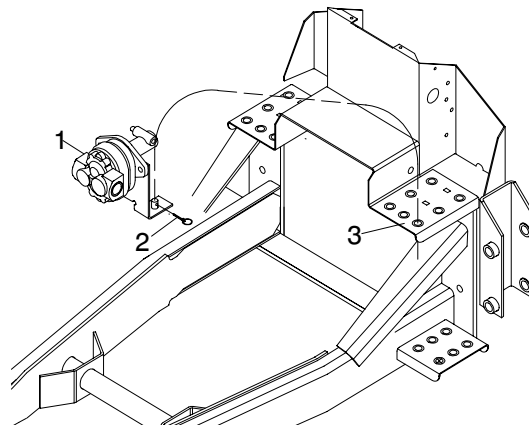
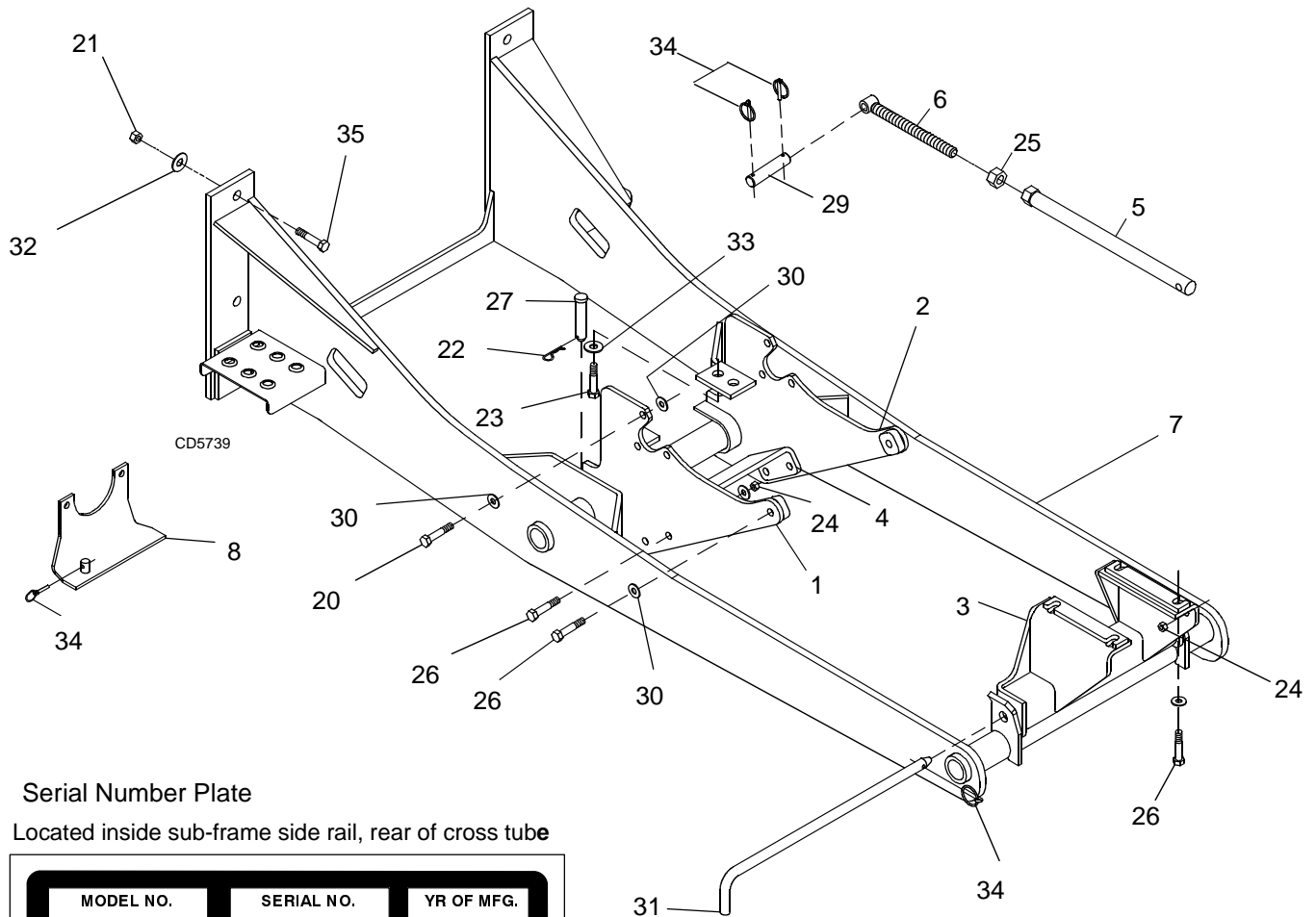

Figure 16 Hydraulic Pump Storage

NOTES

#1001378 SUB-FRAME MOUNTING KIT



Serial Number Plate

Located inside sub-frame side rail, rear of cross tube

MODEL NO.	SERIAL NO.	YR OF MFG.
ID NO.		MASS (KG)

REF	PART	QTY	DESCRIPTION	REF	PART	QTY	DESCRIPTION
1	1001380	1	Right rear support	24	307825	5	M14 x 2.0P Hex nut
2	1001381	1	Left rear support	25	3132	1	1" Hex nut
3	1001383	1	Front support	26	33125	10	M14 x 2.0P x 50mm Cap screw
4	1001387	1	Cross member	27	37827	1	.75 x 3.14 Clevis pin
5	1001579	1	Outer top link 18.5"	29	45087	1	1.0 x 4.5 Pin
6	38645	1	Inner top link	30	46070	22	9/16 Flat washer, hardened
7	46976	1	Sub-frame for BH9000	31	54088	1	Bent pin.75 x 19.36
8	54084	1	Pump Bracket	32	57798	6	3/4 Flat washer, hardened
20	1001575	6	M14 x 2.0P x 55mm Cap screw	33	57817	4	5/8 flat washer, hardened
21	1450	6	3/4 NC Hex nut	34	62043	4	1/4 x 1-3/4 Klik pin
22	2688	2	5/32 Hair pin	35	13759	6	3/4 NC x 2-1/4 Cap screw
23	307434	4	M16 x 2.0P x 45mm Cap screw				

BOLT TORQUE CHART

Always tighten hardware to these values unless a different torque value or tightening procedure is listed for a specific application.

Fasteners must always be replaced with the same grade as specified in the manual parts list.

Always use the proper tool for tightening hardware: SAE for SAE hardware and Metric for metric hardware.

Make sure fastener threads are clean and you start thread engagement properly.

All torque values are given to specifications used on hardware defined by SAE J1701 & J1701M JUL96.

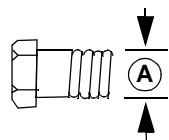

SAE SERIES TORQUE CHART



SAE Bolt Head Identification



**SAE Grade 5
(3 Radial Dashes)**



**SAE Grade 8
(6 Radial Dashes)**

A Diameter (Inches)	Wrench Size	MARKING ON HEAD					
		SAE 2		SAE 5		SAE 8	
		Lbs.-Ft.	N-m	Lbs.-Ft.	N-m	Lbs.-Ft.	N-m
1/4"	7/16"	6	8	10	13	14	18
5/16"	1/2"	12	17	19	26	27	37
3/8"	9/16"	23	31	35	47	49	67
7/16"	5/8"	36	48	55	75	78	106
1/2"	3/4"	55	75	85	115	120	163
9/16"	13/16"	78	106	121	164	171	232
5/8"	15/16"	110	149	170	230	240	325
3/4"	1-1/8"	192	261	297	403	420	569
7/8"	1-15/16"	306	416	474	642	669	907
1"	1-1/2"	467	634	722	979	1020	1383

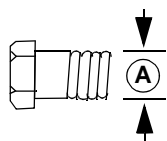

METRIC SERIES TORQUE CHART

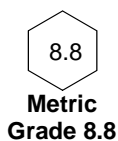

Metric Bolt Head Identification



**10.9
Metric
Grade 10.9**

A Diameter & Thread Pitch (Millimeters)	Wrench Size	COARSE THREAD				FINE THREAD				A Diameter & Thread Pitch (Millimeters)
		MARKING ON HEAD				MARKING ON HEAD				
		Metric 8.8		Metric 10.9		Metric 8.8		Metric 10.9		
		N-m	Lbs.-Ft.	N-m	Lbs.-Ft.	N-m	Lbs.-Ft.	N-m	Lbs.-Ft.	
6 x 1.0	10 mm	8	6	11	8	8	6	11	8	6 x 1.0
8 x 1.25	13 mm	20	15	27	20	21	16	29	22	8 x 1.0
10 x 1.5	16 mm	39	29	54	40	41	30	57	42	10 x 1.25
12 x 1.75	18 mm	68	50	94	70	75	55	103	76	12 x 1.25
14 x 2.0	21 mm	109	80	151	111	118	87	163	120	14 x 1.5
16 x 2.0	24 mm	169	125	234	173	181	133	250	184	16 x 1.5
18 x 2.5	27 mm	234	172	323	239	263	194	363	268	18 x 1.5
20 x 2.5	30 mm	330	244	457	337	367	270	507	374	20 x 1.5
22 x 2.5	34 mm	451	332	623	460	495	365	684	505	22 x 1.5
24 x 3.0	36 mm	571	421	790	583	623	459	861	635	24 x 2.0
30 x 3.0	46 mm	1175	867	1626	1199	1258	928	1740	1283	30 x 2.0

Typical Washer Installations

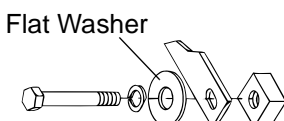
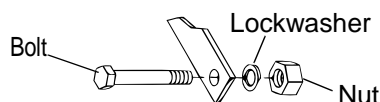

8/900

BOLT SIZE CHART

NOTE: Chart shows bolt thread sizes and corresponding head (wrench) sizes for standard SAE and metric bolts.

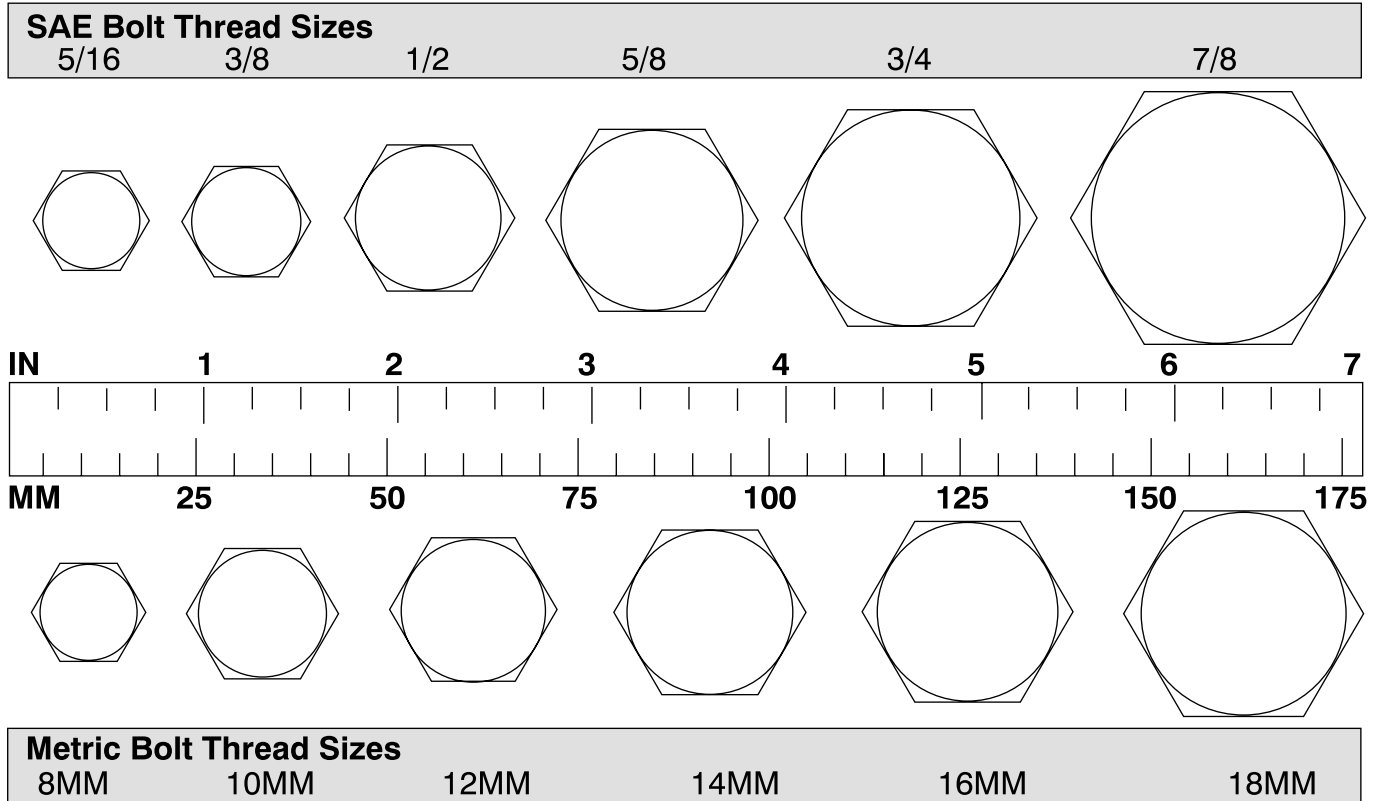

ABBREVIATIONS

AG..... Agriculture
 ATF Automatic Transmission Fluid
 BSPP British Standard Pipe Parallel
 BSPTM British Standard Pipe Tapered Male
 CV..... Constant Velocity
 CCW Counter-Clockwise
 CW..... Clockwise
 F Female
 GA Gauge
 GR (5, etc.)..... Grade (5, etc.)
 HHCS Hex Head Cap Screw
 HT..... Heat Treated
 JIC Joint Industry Council 37° Degree Flare
 LH..... Left Hand
 LT Left
 m..... Meter
 mm..... Millimeter
 M..... Male
 MPa Mega Pascal
 N..... Newton

NC National Coarse
 NF..... National Fine
 NPSM National Pipe Straight Mechanical
 NPT National Pipe Tapered
 NPT SWF..... National Pipe Tapered Swivel Female
 ORBM..... O-Ring Boss - Male
 P Pitch
 PBY Power Beyond
 psi Pounds per Square Inch
 PTO Power Take Off
 QD Quick Disconnect
 RH Right Hand
 ROPS..... Roll Over Protective Structure
 RPM..... Revolutions Per Minute
 RT Right
 SAE Society of Automotive Engineers
 UNC Unified Coarse
 UNF Unified Fine
 UNS Unified Special

WARRANTY

(Replacement Parts For All Models Except Mow'n Machines)

WEC Company, d/b/a Woods Equipment Company ("WOODS"), warrants this product to be free from defect in material and workmanship for a period of ninety (90) days from the date of delivery of the product to the original purchaser.

Under no circumstances will this Warranty apply in the event that the product, in the good faith opinion of WOODS, has been subjected to improper operation, improper maintenance, misuse, or an accident. This Warranty does not cover normal wear or tear, or normal maintenance items.

This Warranty is extended solely to the original purchaser of the product. Should the original purchaser sell or otherwise transfer this product to a third party, this Warranty does not transfer to the third party purchaser in any way. There are no third party beneficiaries of this Warranty.

WOODS' obligation under this Warranty is limited to, at WOODS' option, the repair or replacement, free of charge, of the product if WOODS, in its sole discretion, deems it to be defective or in noncompliance with this Warranty. The product must be returned to WOODS with proof of purchase within thirty (30) days after such defect or noncompliance is discovered or should have been discovered, routed through the dealer and distributor from whom the purchase was made, transportation charges prepaid. WOODS shall complete such repair or replacement within a reasonable time after WOODS receives the product. **THERE ARE NO OTHER REMEDIES UNDER THIS WARRANTY. THE REMEDY OF REPAIR OR REPLACEMENT IS THE SOLE AND EXCLUSIVE REMEDY UNDER THIS WARRANTY.**

THERE ARE NO WARRANTIES WHICH EXTEND BEYOND THE DESCRIPTION ON THE FACE OF THIS WARRANTY. WOODS MAKES NO OTHER WARRANTY, EXPRESS OR IMPLIED, AND WOODS SPECIFICALLY DISCLAIMS ANY IMPLIED WARRANTY OF MERCHANTABILITY AND/OR ANY IMPLIED WARRANTY OF FITNESS FOR A PARTICULAR PURPOSE.

WOODS shall not be liable for any incidental or consequential losses, damages or expenses, arising directly or indirectly from the product, whether such claim is based upon breach of contract, breach of warranty, negligence, strict liability in tort or any other legal theory. Without limiting the generality of the foregoing, Woods specifically disclaims any damages relating to (i) lost profits, business, revenues or goodwill; (ii) loss of crops; (iii) loss because of delay in harvesting; (iv) any expense or loss incurred for labor, supplies, substitute machinery or rental; or (v) any other type of damage to property or economic loss.

This Warranty is subject to any existing conditions of supply which may directly affect WOODS' ability to obtain materials or manufacture replacement parts.

No agent, representative, dealer, distributor, service person, salesperson, or employee of any company, including without limitation, WOODS, its authorized dealers, distributors, and service centers, is authorized to alter, modify, or enlarge this Warranty.

Answers to any questions regarding warranty service and locations may be obtained by contacting:

**Woods Equipment
Company**

2606 Illinois Route 2 South
Post Office Box 1000
Oregon, Illinois 61061

815-732-2141 tel
815-732-7580 fax

WOODS

**WOODS
DUAL
GANNON
ALLOWAY
GILL
GANNONBMP
WAIN ROY
CF
ALITEC**

WARRANTY

(All Models Except Mow'n Machines)

Please Enter Information Below and Save For Future Reference.

Date Purchased: _____ From (Dealer): _____

Model Number: _____ Serial Number: _____

WEC Company, d/b/a Woods Equipment Company ("WOODS"), warrants this product to be free from defect in material and workmanship. Except as otherwise set forth below, the duration of this Warranty shall be for TWELVE (12) MONTHS COMMENCING ON THE DATE OF DELIVERY OF THE PRODUCT TO THE ORIGINAL PURCHASER.

The warranty period for certain gearboxes are listed below:

Model No.	Part Warranted	Duration
1160, 1190, BB600, BB720, BB840, BB6000, BB7200, BB8400	Gearbox components	5 years from the date of delivery.
1130, 3180, 3240, BB48, BB60, BB72, BB84	Gearbox components	3 years from the date of delivery.
XT148, XT160, XT172, XT184	Rotary cutter gearbox	90 days from the date of delivery if used in rental or commercial applications.

Under no circumstances will this Warranty apply in the event that the product, in the good faith opinion of WOODS, has been subjected to improper operation, improper maintenance, misuse, or an accident. This Warranty does not apply in the event that the product has been materially modified or repaired by someone other than WOODS, a WOODS authorized dealer or distributor, and/or a WOODS authorized service center. This Warranty does not cover normal wear or tear, or normal maintenance items. This Warranty also does not cover repairs made with parts other than those obtainable through WOODS.

This Warranty is extended solely to the original purchaser of the product. Should the original purchaser sell or otherwise transfer this product to a third party, this Warranty does not transfer to the third party purchaser in any way. There are no third party beneficiaries of this Warranty.

WOODS makes no warranty, express or implied, with respect to engines, batteries, tires or other parts or accessories not manufactured by WOODS. Warranties for these items, if any, are provided separately by their respective manufacturers.

WOODS' obligation under this Warranty is limited to, at WOODS' option, the repair or replacement, free of charge, of the product if WOODS, in its sole discretion, deems it to be defective or in noncompliance with this Warranty. The product must be returned to WOODS with proof of purchase within thirty (30) days after such defect or noncompliance is discovered or should have been discovered, routed through the dealer and distributor from whom the purchase was made, transportation charges prepaid. WOODS shall complete such repair or replacement within a reasonable time after WOODS receives the product. THERE ARE NO OTHER REMEDIES UNDER THIS WARRANTY. THE REMEDY OF REPAIR OR REPLACEMENT IS THE SOLE AND EXCLUSIVE REMEDY UNDER THIS WARRANTY.

THERE ARE NO WARRANTIES WHICH EXTEND BEYOND THE DESCRIPTION ON THE FACE OF THIS WARRANTY. WOODS MAKES NO OTHER WARRANTY, EXPRESS OR IMPLIED, AND WOODS SPECIFICALLY DISCLAIMS ANY IMPLIED WARRANTY OF MERCHANTABILITY AND/OR ANY IMPLIED WARRANTY OF FITNESS FOR A PARTICULAR PURPOSE.

WOODS shall not be liable for any incidental or consequential losses, damages or expenses, arising directly or indirectly from the product, whether such claim is based upon breach of contract, breach of warranty, negligence, strict liability in tort or any other legal theory. Without limiting the generality of the foregoing, Woods specifically disclaims any damages relating to (i) lost profits, business, revenues or goodwill; (ii) loss of crops; (iii) loss because of delay in harvesting; (iv) any expense or loss incurred for labor, supplies, substitute machinery or rental; or (v) any other type of damage to property or economic loss.

This Warranty is subject to any existing conditions of supply which may directly affect WOODS' ability to obtain materials or manufacture replacement parts.

No agent, representative, dealer, distributor, serviceperson, salesperson, or employee of any company, including without limitation, WOODS, its authorized dealers, distributors, and service centers, is authorized to alter, modify, or enlarge this Warranty.

This Warranty is effective only if the warranty registration card is returned within ten (10) days.

Answers to any questions regarding warranty service and locations may be obtained by contacting:

Woods Equipment Company

2606 Illinois Route 2 South
Post Office Box 1000
Oregon, Illinois 61061

815-732-2141 tel
815-732-7580 fax

**WOODS
DUAL
GANNON
ALLOWAY
GILL
GANNONBMP
WAIN ROY
CF
ALITEC**

PART NO.
MAN0047

**Woods Equipment
Company**

2606 Illinois Route 2 South
Post Office Box 1000
Oregon, Illinois 61061

815-732-2141 tel
815-732-7580 fax

WOODS®