

# WOODS DITCH BANK ROTARY CUTTER

S105-3  
S106-3  
S105Q-3  
S106Q-3

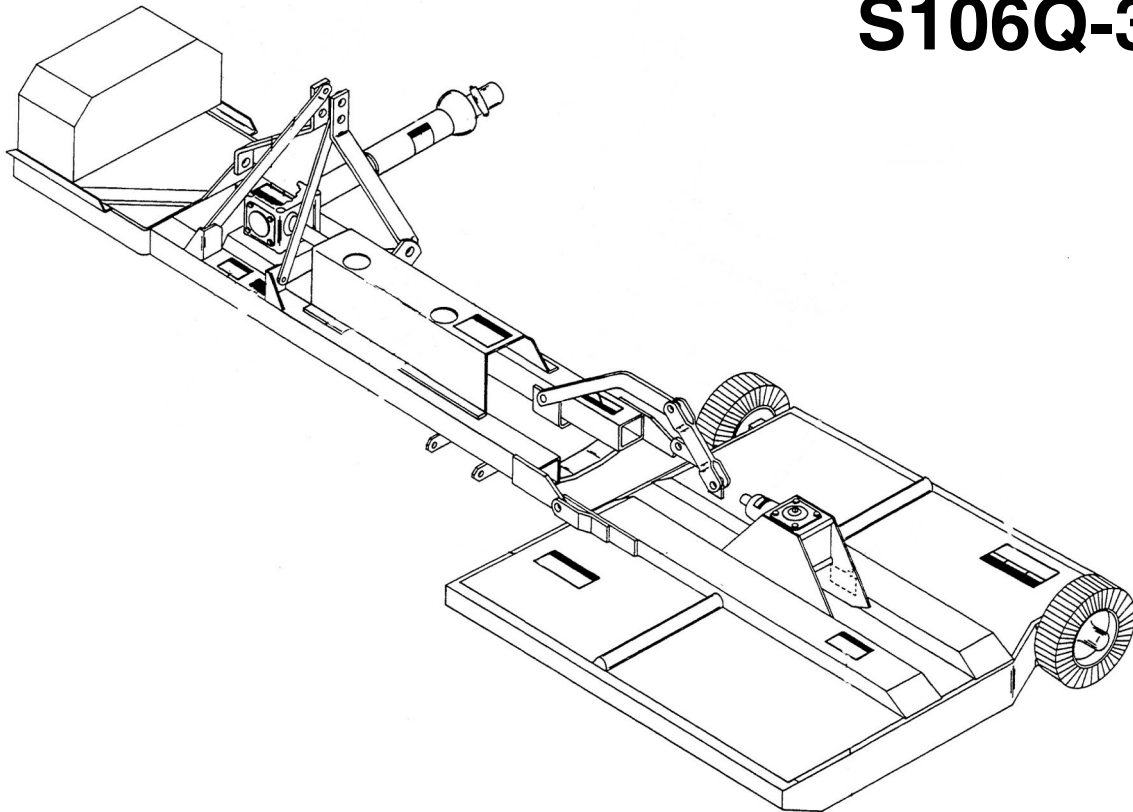

29977  
(Rev. 1/23/2009)

**WOODS®**

OPERATOR'S MANUAL

## TO THE DEALER:

Assembly and proper installation of this product is the responsibility of the Woods® dealer. Read manual instructions and safety rules. Make sure all items on the Dealer's Pre-Delivery and Delivery Check Lists in the Operator's Manual are completed before releasing equipment to the owner.

**The dealer must complete the Product Registration online at the Woods Dealer Website** or complete the mail-in form included with the Operator's Manual. If using the mail-in form, the dealer is to return the prepaid postage portion to Woods, give one copy to the customer, and retain one copy. **Failure to register the product does not diminish customer's warranty rights.**

## TO THE OWNER:

Read this manual before operating your Woods equipment. The information presented will prepare you to do a better and safer job. Keep this manual handy for ready reference. Require all operators to read this manual carefully and become acquainted with all adjustment and operating procedures before attempting to operate. Replacement manuals can be obtained from your dealer. To locate your nearest dealer, check the Dealer Locator at [www.WoodsEquipment.com](http://www.WoodsEquipment.com), or in the United States and Canada call 1-800-319-6637.

The equipment you have purchased has been carefully engineered and manufactured to provide dependable and satisfactory use. Like all mechanical products, it will require cleaning and upkeep. Lubricate the unit as specified. Observe all safety information in this manual and safety decals on the equipment.

For service, your authorized Woods dealer has trained mechanics, genuine Woods service parts, and the necessary tools and equipment to handle all your needs.

Use only genuine Woods service parts. Substitute parts will void the warranty and may not meet standards required for safe and satisfactory operation. Record the model number and serial number of your equipment in the spaces provided:

**Model:** \_\_\_\_\_ **Date of Purchase:** \_\_\_\_\_

**Serial Number: (see Safety Decal section for location)** \_\_\_\_\_

Provide this information to your dealer to obtain correct repair parts.

Throughout this manual, the term **NOTICE** is used to indicate that failure to observe can cause damage to equipment. The terms **CAUTION**, **WARNING**, and **DANGER** are used in conjunction with the Safety-Alert Symbol (a triangle with an exclamation mark) to indicate the degree of hazard for items of personal safety.



This is the safety alert symbol. It is used to alert you to potential personal injury hazards. Obey all safety messages that follow this symbol to avoid possible injury or death.



Indicates a hazardous situation which, if not avoided, will result in death or serious injury.



Indicates a hazardous situation which, if not avoided, could result in death or serious injury.



Indicates a hazardous situation which, if not avoided, could result in minor or moderate injury.

**IMPORTANT**  
or **NOTICE**

Is used to address practices not related to personal injury.

**NOTE**

Indicates helpful information.

**WOODS®**

**ALITEC™**  
**BMP®**  
**CENTRAL FABRICATORS®**  
**GANNON®**  
**GILL®**  
**WAIN-ROY®**  
**WOODS®**

## 2 Introduction

Gen'l (Rev. 2/19/2008)

# TABLE OF CONTENTS

INTRODUCTION.....	2
SPECIFICATIONS.....	4
GENERAL INFORMATION .....	4
SAFETY VIDEO ORDER FORM.....	5
SAFETY RULES .....	7
SAFETY DECALS.....	10
OPERATION .....	13
OWNER SERVICE .....	17
TROUBLESHOOTING.....	20
DEALER SERVICE .....	21
DEALER CHECK LISTS .....	28
ASSEMBLY.....	29
PARTS INDEX.....	35
BOLT TORQUE CHART .....	54
BOLT SIZE CHART AND ABBREVIATIONS .....	55
INDEX .....	56
PRODUCT WARRANTY .....	57
REPLACEMENT PARTS WARRANTY .....	BACK COVER



**¡LEA EL INSTRUCTIVO!**

Si no lee Ingles, pida ayuda a alguien que si lo lea para que le traduzca las medidas de seguridad.



**This Operator's Manual should be regarded as part of the machine. Suppliers of both new and second-hand machines must make sure that this manual is provided with the machine.**

# SPECIFICATIONS

	<u>S105</u>	<u>S105Q</u>	<u>S106</u>	<u>S106Q</u>
<b>Cutting Width</b>	60"	60"	72"	72"
<b>PTO Speed (rpm)</b>	540	1000	540	1000
<b>Blade Tip Speed (feet per minute)</b>	11,451	14,137	10,178	12,566
<b>Minimum Tractor Weight Recommended</b>	4000 lbs	4000 lbs	5000 lbs	5000 lbs
<b>Minimum Tractor HP Recommended</b>	40 HP	40 HP	50 HP	50 HP
<b>Minimum 3-Point Lift Capacity</b>	2500 lbs	2500 lbs	3000 lbs	3000 lbs

Cutting Height (Depending on 3-point hitch height) . . . . . 1-1/2" - 12"  
 3-Point Hitch (Category 1 pins are available) . . . . . Category 2  
 Offset from Centerline Tractor PTO to Inside Edge of Cut (Approximate) . . . . . 63"  
 Transport Width from Centerline PTO to Right Side with Head Raised (Approximate) . . . . . 70"

## GENERAL INFORMATION



■ **Some illustrations in this manual show the cutter with safety shields removed to provide a better view. The cutter should never be operated with any safety shielding removed.**

The purpose of this manual is to assist you in operating and maintaining your cutter. Read it carefully. It furnishes information and instructions that will help you achieve years of dependable performance. These instructions have been compiled from extensive field experience and engineering data. Some information may be general in nature due to unknown and varying

operating conditions. However, through experience and these instructions, you should be able to develop procedures suitable to your particular situation.

The illustrations and data used in this manual were current at the time of printing, but due to possible inline production changes, your machine may vary slightly in detail. We reserve the right to redesign and change the machines as may be necessary without notification.

Throughout this manual, references are made to right and left directions. These are determined by standing behind the equipment facing the direction of forward travel. Blade rotation is clockwise as viewed from the top of the cutter.

**BE SAFE!**

**BE ALERT!**

**BE ALIVE!**

**BE TRAINED**

**Before Operating Mowers!**



*Safety Training  
Does Make a Difference.*

---

## **Free Mower Safety Video**

Fill out and return the order form and we will send you a FREE VHS or DVD video outlining ***Industrial and Agricultural Mower Safety Practices***. The 22 minute video, developed in cooperation with AEM (Association of Equipment Manufacturers), reinforces the proper procedures to follow while operating your mowing equipment. The video does not replace the information contained in the Operator's Manual, so please review this manual thoroughly before operating your new mowing equipment.

**Also, available from the Association of Equipment Manufacturers:**

A large variety of training materials (ideal for groups) are available for a nominal charge from AEM. Following is a partial list:

- **Training Package for Rotary Mowers/Cutters-English**  
Contains: DVD & VHS (English)  
    Guidebook for Rotary Mowers/Cutters (English)  
    AEM Industrial/Agricultural Mower Safety Manual (English)  
    AEM Agricultural Tractor Safety Manual (English)
- **Training Package for Rotary Mowers/Cutters-English/Spanish**  
Contains: DVD & VHS (English/Spanish)  
    Guidebook for Rotary Mowers/Cutters (English/Spanish)  
    AEM Industrial/Agricultural Mower Safety Manual (English/Spanish)  
    AEM Agricultural Tractor Safety Manual (English/Spanish)

AEM training packages are available through:

AEM at: [www.aem.org](http://www.aem.org)

or

Universal Lithographers, Inc.

Email: [aem@ulilitho.com](mailto:aem@ulilitho.com)

800-369-2310 tel

866-541-1668 fax



---

## Free Mower/Cutter Safety Video Order Form

- Please send me  (Select one)
- VHS** Format - VHS01052 Safety Video
- DVD** Format - DVD01052 Safety Video

Name: \_\_\_\_\_ Phone: \_\_\_\_\_

Address: \_\_\_\_\_  
\_\_\_\_\_  
\_\_\_\_\_

Mower/Cutter Model: \_\_\_\_\_ Serial #: \_\_\_\_\_

Send to: **ATTENTION: DEALER SERVICES**  
**WOODS EQUIPMENT COMPANY**  
PO BOX 1000  
OREGON IL 61061-1000

# SAFETY RULES



**ATTENTION! BECOME ALERT! YOUR SAFETY IS INVOLVED!**



Safety is a primary concern in the design and manufacture of our products. Unfortunately, our efforts to provide safe equipment can be wiped out by an operator's single careless act.

In addition to the design and configuration of equipment, hazard control and accident prevention are dependent upon the awareness, concern, judgement, and proper training of personnel involved in the operation, transport, maintenance, and storage of equipment.

It has been said, "The best safety device is an informed, careful operator." We ask you to be that kind of operator.

## **INSTALLATION**

■ Hydraulics must be connected as instructed in this manual. Do not substitute parts, modify, or connect in any other way.

## **TRAINING**

■ Safety instructions are important! Read all attachment and power unit manuals; follow all safety rules and safety decal information. (Replacement manuals and safety decals are available from your dealer. To locate your nearest dealer, check the Dealer Locator at [www.WoodsEquipment.com](http://www.WoodsEquipment.com), or in the United States and Canada call 1-800-319-6637.) Failure to follow instructions or safety rules can result in serious injury or death.

■ If you do not understand any part of this manual and need assistance, see your dealer.

■ Know your controls and how to stop engine and attachment quickly in an emergency.

■ Operators must be instructed in and be capable of the safe operation of the equipment, its attachments, and all controls. Do not allow anyone to operate this equipment without proper instructions.

■ Keep hands and body away from pressurized lines. Use paper or cardboard, not hands or other body parts to check for leaks. Wear safety goggles. Hydraulic fluid under pressure can easily penetrate skin and will cause serious injury or death.

■ Make sure that all operating and service personnel know that if hydraulic fluid penetrates skin, it must be surgically removed as soon as possible by a doctor familiar with this form of injury or gangrene, serious injury, or death will result. **CONTACT A PHYSICIAN IMMEDIATELY IF FLUID ENTERS SKIN OR EYES. DO NOT DELAY.**

■ Never allow children or untrained persons to operate equipment.

## **PREPARATION**

■ Check that all hardware is properly installed. Always tighten to torque chart specifications unless instructed otherwise in this manual.

■ Air in hydraulic systems can cause erratic operation and allows loads or equipment components to drop unexpectedly. When connecting equipment or hoses or performing any hydraulic maintenance, purge any air in hydraulic system by operating all hydraulic functions several times. Do this before putting into service or allowing anyone to approach the equipment.

■ Make sure all hydraulic hoses, fittings, and valves are in good condition and not leaking before starting power unit or using equipment. Check and route hoses carefully to prevent damage. Hoses must not be twisted, bent sharply, kinked, frayed, pinched, or come into contact with any moving parts. Operate moveable components through full operational range to check clearances. Replace any damaged hoses immediately.

■ After connecting hoses, check that all control lever positions function as instructed in the Operator's Manual. Do not put into service until control lever and equipment movements are correct.

■ Set tractor hydraulic relief valve at 2500 psi (170 bars) (17,000 kPa) to prevent injury and equipment damage due to hydraulic system failure.

■ Your dealer can supply original equipment hydraulic accessories and repair parts. Substitute parts may not meet original equipment specifications and may be dangerous.

■ Always wear relatively tight and belted clothing to avoid getting caught in moving parts. Wear sturdy, rough-soled work shoes and protective equipment for eyes, hair, hands, hearing, and head; and respirator or filter mask where appropriate.

■ Make sure spring-activated locking pin or collar slides freely and is seated firmly in tractor PTO spline groove.

■ Make sure attachment is properly secured, adjusted, and in good operating condition.

*(Safety Rules continued on next page)*

# SAFETY RULES



**ATTENTION! BECOME ALERT! YOUR SAFETY IS INVOLVED!**



*(Safety Rules continued from previous page)*

■ Power unit must be equipped with ROPS or ROPS cab and seat belt. Keep seat belt securely fastened. Falling off power unit can result in death from being run over or crushed. Keep foldable ROPS system in “locked up” position at all times.

■ Remove accumulated debris from this equipment, power unit, and engine to avoid fire hazard.

■ Make sure all safety decals are installed. Replace if damaged. (See Safety Decals section for location.)

■ Make sure shields and guards are properly installed and in good condition. Replace if damaged.

■ You must use a center frame counterweight box filled with steel to a minimum 400 lbs.

■ Do not put this equipment into service unless all side skids are properly installed and in good condition. Replace if damaged.

■ A minimum 20% of tractor and equipment weight must be on the tractor front wheels when attachments are in transport position. Without this weight, tractor could tip over, causing personal injury or death. The weight may be attained with a loader, front wheel weights, ballast in tires or front tractor weights. Weigh the tractor and equipment. Do not estimate.

■ Inspect and clear area of stones, branches, or other hard objects that might be thrown, causing injury or damage.

## TRANSPORTATION

■ Power unit must be equipped with ROPS or ROPS cab and seat belt. Keep seat belt securely fastened. Falling off power unit can result in death from being run over or crushed. Keep foldable ROPS system in “locked up” position at all times.

■ Before transporting, stop tractor PTO, raise cutter center section, then raise cutter head, and install transport bar. A raised cutter head can fall and crush. Keep away; never go underneath. Lower cutter head after transport and for storage.

■ Always comply with all state and local lighting and marking requirements.

■ Never allow riders on power unit or attachment.

■ Do not operate PTO during transport.

■ Do not operate or transport on steep slopes.

■ Do not operate or transport equipment while under the influence of alcohol or drugs.

■ Use additional caution and reduce speed when under adverse surface conditions, turning, or on inclines.

## OPERATION

■ Do not allow bystanders in the area when operating, attaching, removing, assembling, or servicing equipment.

■ Never walk, stand, or place yourself or others under a raised wing or in the path of a lowering wing. Hydraulic system leak-down, hydraulic system failures, mechanical failures, or movement of control levers can cause wings to drop unexpectedly and cause severe injury or death.

■ Full chain shielding must be installed when operating in populated areas or other areas where thrown objects could injure people or damage property.

- If this machine is not equipped with full chain shielding, operation must be stopped when anyone comes within 300 feet (92 m).

- This shielding is designed to reduce the risk of thrown objects. The mower deck and protective devices cannot prevent all objects from escaping the blade enclosure in every mowing condition. It is possible for objects to ricochet and escape, traveling as much as 300 feet (92 m).

■ Never direct discharge toward people, animals, or property.

■ Do not operate or transport equipment while under the influence of alcohol or drugs.

■ Operate only in daylight or good artificial light.

■ Keep hands, feet, hair, and clothing away from equipment while engine is running. Stay clear of all moving parts.

■ Never allow riders on power unit or attachment.

■ Power unit must be equipped with ROPS or ROPS cab and seat belt. Keep seat belt securely fastened. Falling off power unit can result in death from being run over or crushed. Keep foldable ROPS system in “locked up” position at all times.

■ Always sit in power unit seat when operating controls or starting engine. Securely fasten seat belt, place transmission in neutral, engage brake, and ensure all other controls are disengaged before starting power unit engine.



# SAFETY RULES



**ATTENTION! BECOME ALERT! YOUR SAFETY IS INVOLVED!**



- Operate tractor PTO at 540 RPM (1000 RPM on Q Series cutters). Do not exceed.
- Raise or lower wings slowly to prevent personal injury or damage to cutter.
- Look down and to the rear and make sure area is clear before operating in reverse.
- Do not operate or transport on steep slopes.
- Do not stop, start, or change directions suddenly on slopes.
- Watch for hidden hazards on the terrain during operation.
- Stop power unit and equipment immediately upon striking an obstruction. Turn off engine, remove key, inspect, and repair any damage before resuming operation.

## MAINTENANCE

- Before dismounting power unit or performing any service or maintenance, follow these steps: disengage power to equipment, lower the 3-point hitch and all raised components to the ground, operate valve levers to release any hydraulic pressure, set parking brake, stop engine, remove key, and unfasten seat belt.
- Before performing any service or maintenance, lower attachment to ground, turn off engine, set parking brake, and remove key.
- Do not modify or alter or permit anyone else to modify or alter the equipment or any of its components in any way.
- Your dealer can supply original equipment hydraulic accessories and repair parts. Substitute parts may not meet original equipment specifications and may be dangerous.
- To prevent contamination, clean and then cover hose ends, fittings, and hydraulic ports with tape.
- Do not allow bystanders in the area when operating, attaching, removing, assembling, or servicing equipment.
- Never go underneath equipment (lowered to the ground or raised) unless it is properly blocked and secured. Never place any part of the body underneath equipment or between moveable parts even when the engine has been turned off. Hydraulic system leak down, hydraulic system failures, mechanical failures, or movement of control levers can cause equipment to drop or rotate unexpectedly and cause severe injury or death. Follow Oper-

ator's Manual instructions for working underneath and blocking requirements or have work done by a qualified dealer.

- Make sure attachment is properly secured, adjusted, and in good operating condition.
- Keep all persons away from operator control area while performing adjustments, service, or maintenance.
- Make certain all movement of equipment components has stopped before approaching for service.
- Frequently check blades. They should be sharp, free of nicks and cracks, and securely fastened.
- Do not handle blades with bare hands. Careless or improper handling may result in serious injury.
- Your dealer can supply genuine replacement blades. Substitute blades may not meet original equipment specifications and may be dangerous.
- Tighten all bolts, nuts, and screws to torque chart specifications. Check that all cotter pins are installed securely to ensure equipment is in a safe condition before putting unit into service.
- Make sure all safety decals are installed. Replace if damaged. (See Safety Decals section for location.)
- Make sure shields and guards are properly installed and in good condition. Replace if damaged.
- Never perform service or maintenance with engine running.
- Do not disconnect hydraulic lines until machine is securely blocked or placed in lowest position and system pressure is released by operating valve levers.
- Service and maintenance work not covered in OWNER SERVICE must be done by a qualified dealership. Special skills, tools, and safety procedures may be required. Failure to follow these instructions can result in serious injury or death.

## STORAGE

- Keep children and bystanders away from storage area.
- Store on level, solid ground.
- Block equipment securely for storage.

# SAFETY & INSTRUCTIONAL DECALS



**ATTENTION! BECOME ALERT! YOUR SAFETY IS INVOLVED!**



**Replace Immediately If Damaged!**

## 11 - SERIAL NUMBER PLATE



DC2312B

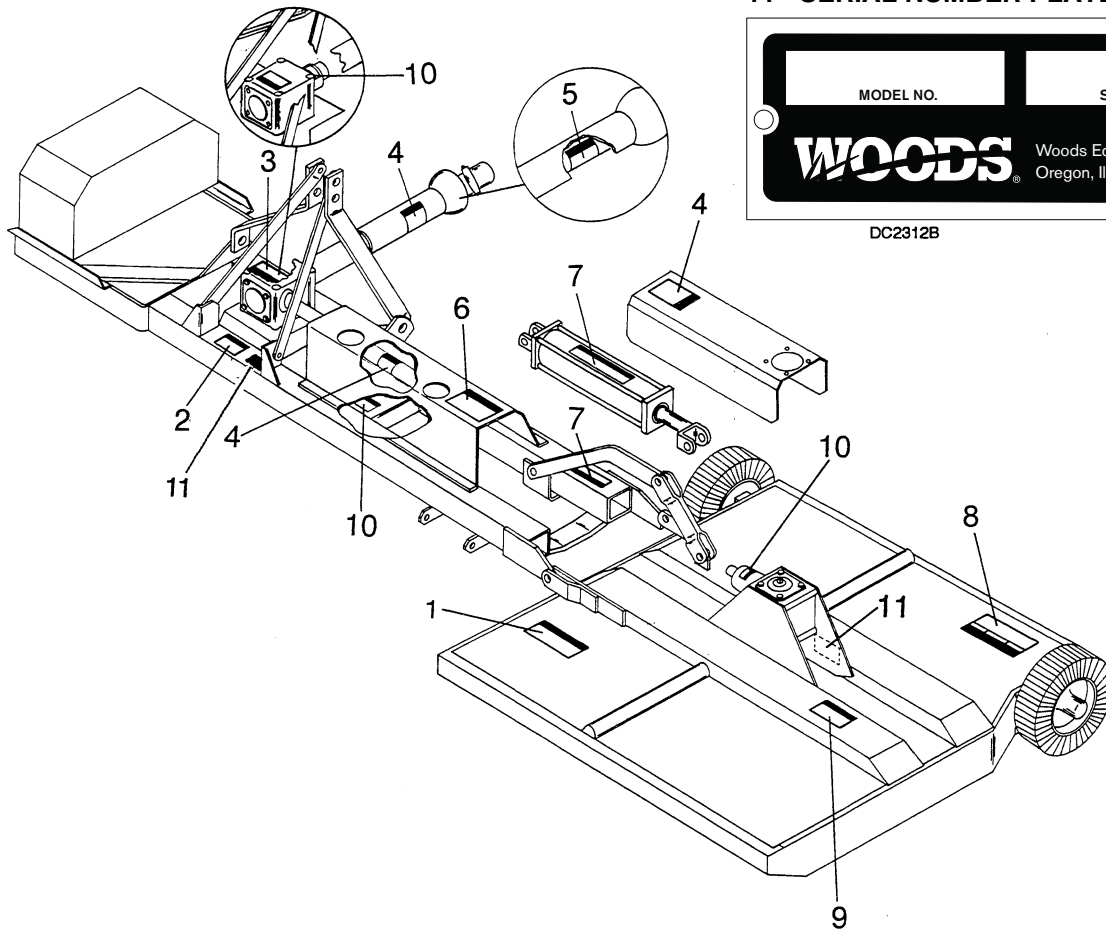

1 - PN 32005

### **WARNING**

#### TO AVOID SERIOUS INJURY OR DEATH,

- Read Operator's Manual and follow all safety, operating, and service instructions. (Contact dealer for manuals.)
- Keep all guards and shields in place and in good condition.
- Lower implement, shut off, and remove key before leaving or servicing.
- Block up equipment and remove key before working underneath.
- Never allow children or unqualified persons to operate.
- Clear mowing area of all debris.
- Be careful on uneven terrain. Reduce speed when turning.

32005-E

2 - PN 25023

### **DANGER**



#### KEEP AWAY!

- ENTANGLEMENT WITH ROTATING DRIVE PARTS OR FALLING OFF CAN CAUSE INJURY OR DEATH.
- KEEP ALL DRIVE SHIELDS AND GUARDS IN PLACE AND IN GOOD CONDITION.
- ALLOW NO RIDERS.

25023-H

(Safety Decals continued on next page)

# SAFETY & INSTRUCTIONAL DECALS



**ATTENTION! BECOME ALERT! YOUR SAFETY IS INVOLVED!**



**Replace Immediately If Damaged!**

(Safety Decals continued from previous page)

3 - PN 62211

<b>WARNING</b>
<b>540 RPM SPEED RANGE ONLY</b>
HIGHER PTO SPEEDS CAN CAUSE PERSONAL INJURY AND EQUIPMENT FAILURE.
62211

-or-

3 - PN 23376

<b>CAUTION</b>
<b>ALWAYS USE 1000 RPM PTO SPEED.</b>
23376

4 - PN 29029

<b>DANGER</b>
<b>KEEP AWAY! ROTATING DRIVE LINE</b>
<ul style="list-style-type: none"> <li>■ ENTANGLEMENT CAN CAUSE SERIOUS INJURY OR DEATH.</li> <li>■ KEEP ALL DRIVE SHIELDS AND GUARDS IN PLACE AND IN GOOD CONDITION.</li> <li>■ TRACTOR PTO YOKE MUST BE LOCKED IN PLACE.</li> <li>■ ADJUST TRACTOR HITCH TO PROPER DIMENSIONS.</li> </ul>
29029

6 - PN 28527

<b>DANGER</b>
<b>TO AVOID SERIOUS INJURY OR DEATH,</b>
<ul style="list-style-type: none"> <li>■ Use roll-over protective structure and seat belts with this equipment.</li> <li>■ Use this mower only on tractors of sufficient size and weight to avoid tractor upset.</li> <li>■ Never operate tractor on steep bank with mower on downhill side, as tractor could overturn.</li> <li>■ Use extreme caution when mowing along steep banks to avoid wash-outs, cave-ins or side draft which could pull tractor off embankment.</li> <li>■ Use cab or protective enclosure and mower chain shielding when mowing banks below grade level to protect operator from thrown objects.</li> <li>■ Always latch lock-up bar and chain for transport.</li> <li>■ Never leave tractor unattended with unit in raised position.</li> </ul>
28527-G

5 - PN 33347

<b>DANGER</b>
<b>GUARD MISSING. DO NOT OPERATE.</b>
<b>DANGER</b>
<b>GUARD MISSING. DO NOT OPERATE.</b>
33347E
<b>DANGER</b>

7 - PN 19924

	<b>WARNING</b>
	<b>HIGH-PRESSURE HYDRAULIC OIL LEAKS CAN PENETRATE SKIN RESULTING IN SERIOUS INJURY, GANGRENE OR DEATH.</b>
	<ul style="list-style-type: none"> <li>■ Check for leaks with cardboard; never use hand.</li> <li>■ Before loosening fittings: lower load, release pressure, and be sure oil is cool.</li> <li>■ Consult physician immediately if skin penetration occurs.</li> </ul>
19924-B	

**SAFETY & INSTRUCTIONAL DECALS**  
**ATTENTION! BECOME ALERT! YOUR SAFETY IS INVOLVED!**  
**Replace Immediately If Damaged!**

8 - PN 32241

 <b>DANGER</b>			
			
<p><b>KEEP AWAY – ROTATING BLADES</b> <b>SERIOUS INJURY OR DEATH CAN RESULT FROM THROWN OBJECTS OR BLADE CONTACT.</b></p> <ul style="list-style-type: none"><li>■ DO NOT STAND ON OR NEAR MOWER WHEN RUNNING.</li><li>■ FULL CHAIN SHIELDING MUST BE USED TO COMPLY WITH OSHA AG STANDARD 1928.57, SAE J232, AND ANSI B71.4, UNLESS IT INTERFERES SUBSTANTIALLY WITH MOWER FUNCTION DURING AG USE. IF NOT FULLY SHIELDED, STOP OPERATION WHEN ANYONE COMES WITHIN SEVERAL HUNDRED FEET.</li></ul> <p style="text-align: right;"><small>32241</small></p>			

9 - PN 26483

 <b>CAUTION</b>
LOOK AND LISTEN FOR ROTATION. DO NOT OPEN COVER UNTIL ALL COMPONENTS HAVE STOPPED.
<small>26483-H</small>

**BE CAREFUL!**

Use a clean, damp cloth to clean safety decals.

Avoid spraying too close to decals when using a pressure washer; high-pressure water can enter through very small scratches or under edges of decals causing them to peel or come off.

Replacement safety decals can be ordered free from your Woods dealer. To locate your nearest dealer, check the Dealer Locator at [www.WoodsEquipment.com](http://www.WoodsEquipment.com), or in the United States and Canada call 1-800-319-6637.

# OPERATION

The operator is responsible for the safe operation of the cutter. The operator must be properly trained. Operators should be familiar with the cutter, the tractor, and all safety practices before starting operation. Read the safety rules and safety decals on page 7 through page 12.

This machine is a heavy-duty cutter designed for ditch-bank and side bank mowing. Five foot and six foot cutting heads are available in 540 rpm and 1000 rpm models.

The 1000 rpm unit is designated with the marking "1000 rpm" on the front and rear center frame, and the input gearbox has a "1000 rpm" tag attached to it.

## DANGER

■ Full chain shielding must be installed when operating in populated areas or other areas where thrown objects could injure people or damage property.

- If this machine is not equipped with full chain shielding, operation must be stopped when anyone comes within 300 feet (92 m).
- This shielding is designed to reduce the risk of thrown objects. The mower deck and protective devices cannot prevent all objects from escaping the blade enclosure in every mowing condition. It is possible for objects to ricochet and escape, traveling as much as 300 feet (92 m).

## WARNING

- Never allow children or untrained persons to operate equipment.
- Keep bystanders away from equipment.
- Never allow riders on power unit or attachment.
- Keep all persons away from operator control area while performing adjustments, service, or maintenance.

## CAUTION

- Stop power unit and equipment immediately upon striking an obstruction. Turn off engine, remove key, inspect, and repair any damage before resuming operation.
- Always wear relatively tight and belted clothing to avoid getting caught in moving parts. Wear sturdy, rough-soled work shoes and protective equipment for eyes, hair, hands, hearing, and head; and respirator or filter mask where appropriate.

■ Operate tractor PTO at 540 RPM (1000 RPM on Q Series cutters). Do not exceed.

## GENERAL TRACTOR REQUIREMENTS

Mount on tractors of adequate size; 4000 lbs minimum weight for S105, and 5000 lbs minimum weight for S106. Tractors should have a minimum 3-point lift capacity of 2500 lbs for the S105 and 3000 lbs for the S106.

Stabilizer bars must be used on lower 3-point hitch arms to minimize cutter side to side sway.

An adjustable, rigid top link must be used to achieve the tilt adjustments.

## TRACTOR FRONT END STABILITY

### WARNING

■ A minimum 20% of tractor and equipment weight must be on the tractor front wheels when attachments are in transport position. Without this weight, tractor could tip over, causing personal injury or death. The weight may be attained with a loader, front wheel weights, ballast in tires or front tractor weights. Weigh the tractor and equipment. Do not estimate.

■ You must use a center frame counterweight box filled with steel to a minimum 400 lbs.

The use of 3-point mounted equipment can cause loss of tractor front end stability.

If there is any question at all of the tractor stability or the tractor rockshaft strength, use a counterweight of approximately 400 lbs or more on left end of cutter center frame. The rockshaft is required to carry all torsion load resulting from cutter head weight. Adding weight to the left side of the cutter frame reduces the torsion load.

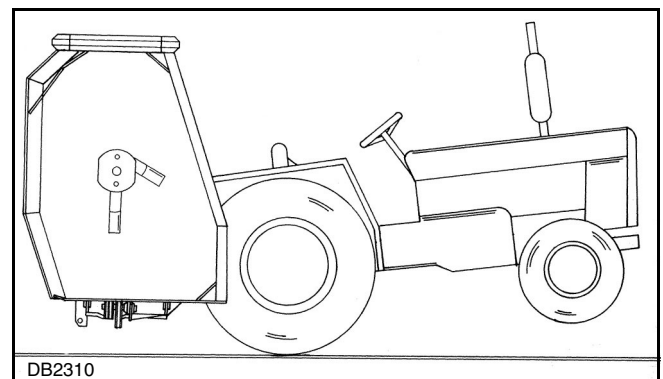

Figure 1. Tractor Stability

## **ATTACHING CUTTER TO TRACTOR**

The cutter is shipped with Category 2 hitch pins. Optional Category 1 pins may be substituted.

Attach check chain keyhole plates - one on each side of tractor top link attaching lug.

Attach cutter center section to tractor 3-point hitch. Be sure to use adjustable rigid top link. If tractor top link pin is too short, use a 3/4 x 6" bolt.

### **PTO Drive Shaft**

The standard drive shaft for this cutter is intended for use with tractors having from 15" - 24" between the end of PTO shaft and hitch pin holes of lower 3-point lift arms when they are horizontal.

When PTO/hitch pin distance is less than 15", slip tubes of PTO shaft can bottom out when operating over uneven terrain.

When PTO/hitch pin distance is longer than 24", there may not be sufficient engagement when operating over uneven terrain. Longer drive halves are available (refer to parts list on page 40).

### **WARNING**

■ **Make sure spring-activated locking pin or collar slides freely and is seated firmly in tractor PTO spline groove.**

### **CUTTING HEIGHT & ATTITUDE ADJUSTMENT**

Place tractor and cutter on a level area. Lower cutting head (parallel to ground but suspended in air). Adjust tractor 3-point lower arms to position cutter center section level from side to side and level with the cutting head. On some tractors, the left lift arm can telescope up or be locked down. When using this cutter, it must be locked down.

With center section height adjusted, adjust tractor top link to position front of cutter head approximately 1/2" to 1" lower than the rear for normal cutting.

Gauge wheels may be adjusted to four different settings. Set the inside and outside wheels in the same hole at the desired cutting height.

Check chains are optional but are recommended. Adjust check chains to carry the cutter level and at desired height when 3-point lift is released and allowed to return to its lowest position.

### **SIDE SKID ADJUSTMENT**

Side skids are designed to carry cutter head over uneven ground and minimize scalping. With the cutting

height set and cutter level, set outer skid 1/2" above ground level and inner skid 1" above ground.

Do not operate cutter with skids in constant contact with the ground.

### **OPTIONAL TAILWHEEL ADJUSTMENT**

The tailwheel is optional and is designed to be used on the center section. The tailwheel will share the torsional loads when mowing steep ditch banks. Set the tailwheel to ride on the ground after all other adjustments are made.

### **PRE-OPERATION CHECK LIST**

#### **Owner's Responsibility**

- \_\_\_ Check to ensure blades are sharp, secure, and cutting edges are positioned in the direction of crossbar rotation.
- \_\_\_ Check to be sure each gearbox is half full of 90W gear lube and has vent plug installed.
- \_\_\_ Check to ensure PTO shaft and cutter head universal joints and all other lubrication points are properly serviced.
- \_\_\_ Check to ensure all safety shielding is properly installed and in good condition.
- \_\_\_ Check to ensure PTO shielding rotates freely.
- \_\_\_ Clear mowing area of debris that could be picked up and thrown by cutter.
- \_\_\_ Check cutting height and cutter attitude.
- \_\_\_ Place tractor PTO and transmission in neutral before attempting to start engine.
- \_\_\_ Review and follow all safety practices presented on page 7 through page 12.

### ***NOTICE***

■ **Make sure all hydraulic connections are tight and all hydraulic lines and hoses are in good condition before engaging tractor PTO.**

### **WARNING**

■ **Keep hands and body away from pressurized lines. Use paper or cardboard, not hands or other body parts to check for leaks. Wear safety goggles. Hydraulic fluid under pressure can easily penetrate skin and will cause serious injury or death.**

■ **Make sure that all operating and service personnel know that if hydraulic fluid penetrates skin, it must be surgically removed as soon as possible by a doctor familiar with this form of injury or gangrene, serious injury, or death will result. CONTACT A PHYSICIAN IMMEDIATELY IF FLUID ENTERS SKIN OR EYES. DO NOT DELAY.**

## **WARNING**

- **Do not disconnect hydraulic lines until machine is securely blocked or placed in lowest position and system pressure is released by operating valve levers.**

### **GENERAL MOWING**

## **WARNING**

- **Look down and to the rear and make sure area is clear before operating in reverse.**

This cutter may be used for mowing in either forward or reverse. Reverse mowing will enable you to cut close to obstructions. When mowing in both directions, cutter should be level front to rear.

### **Blade Selection**

## **CAUTION**

- **Your dealer can supply genuine replacement blades. Substitute blades may not meet original equipment specifications and may be dangerous.**

General purpose suction blades are recommended for normal mowing. Flat blades are recommended for brush mowing and in sandy areas where abrasive action could cause excessive blade wear. Final blade selection must be left to your judgement, depending on the job to be accomplished and the desired results.

### **Cutter Head Hydraulic Lift**

The cutter head is raised with a 3-1/2" single-acting hydraulic cylinder. The cylinder, which lifts only, may be controlled by either tractor hydraulic controls or an optional auxiliary hydraulic valve. The head is lowered by gravity.

There is an orifice restrictor in the hydraulic line to control the fall.

### ***NOTICE***

- **Always raise center section before raising or lowering cutter head. This will provide clearance for the inside gauge wheel. Failure to raise center section will result in rolling tire off of rim.**
- **Never install a double-acting cylinder as damage to the cutter will occur.**

When mowing, set hydraulic valve in the float position. This will allow cutter to follow the ground contour.

Always use the tractor hydraulic system with built-in float when available. On tractors with closed-center systems that do not have float, you may lock the control in the down mode. This will allow the head to float.

Do not lock the control in the down mode on tractors with open-center systems. Refer to the tractor owner's manual or contact your dealer if you have questions as to the type of hydraulic system used on your tractor.

Operate the open-center system that does not have a float with the control in the neutral position. This will allow cutter head to float up when encountering an obstruction.

For tractors without hydraulic controls, an auxiliary control valve may be used. It has three positions: pull out to raise, push in to slightly lower, and push all the way in and snap into detent to allow cutter head to float.

### **Tractor and Cutter Operation**

## **DANGER**

- **Full chain shielding must be installed when operating in populated areas or other areas where thrown objects could injure people or damage property.**

- **If this machine is not equipped with full chain shielding, operation must be stopped when anyone comes within 300 feet (92 m).**
- **This shielding is designed to reduce the risk of thrown objects. The mower deck and protective devices cannot prevent all objects from escaping the blade enclosure in every mowing condition. It is possible for objects to ricochet and escape, traveling as much as 300 feet (92 m).**

## **WARNING**

- **Keep bystanders away from equipment.**
- **Never allow riders on power unit or attachment.**

This cutter is operated with tractor controls. Engage the PTO control at idle rpm to prevent undue stress on tractor, cutter drivelines and gearboxes. Set tractor PTO speed and tractor throttle to operate at either 540 rpm or 1000 rpm, depending on which model cutter you have. Change ground travel by using higher or lower gears. Be sure operator is familiar with all tractor controls and can stop it and the cutter in an emergency. The operator should give complete, undivided attention to operating the tractor and cutter when mowing.

## Brush and Ditch Bank Mowing

### **⚠ WARNING**

- Never direct discharge toward people, animals, or property.
- Do not raise cutter head with PTO engaged. A raised cutter head exposes blades and increases thrown object hazards. Always operate with cutter head close to surface being cut.

When operating this cutter on ditch banks and cutting brush, the operator must be alert. Should the cutter hit an obstruction, the front of the tractor will usually slide toward the ditch (to the right). It would be possible to run the tractor and cutter into the ditch if mowing speed is too high or operator is not alert. On steep banks, it may be necessary to use the left turning brake to counteract the load occurring when cutter is hitting brush.

This cutter can handle brush up to 3" without serious damage if reasonable judgement is used. Sometimes, in ditches, it is well to raise the center section and cutter head as high as needed and then lower it gradually onto top of brush. This will produce a good shredding job and usually is the best method for heavy brush.

When mowing steep banks with cutter on the uphill side, it is possible to raise cutter head high enough to over-center and make it difficult to lower. When this occurs, it will be necessary to maneuver tractor to cause lowering to take place.

## **TRANSPORT**

### **⚠ WARNING**

- Before transporting, stop tractor PTO, raise cutter center section, then raise cutter head and install transport bar. A raised cutter head can fall and crush. Keep away; never go underneath. Lower cutter head after transport and for storage.

When transporting the machine or working on the underside, attach lock-up bar (1) to center frame (5), using clevis pin (2), and secure with klik pin (3).

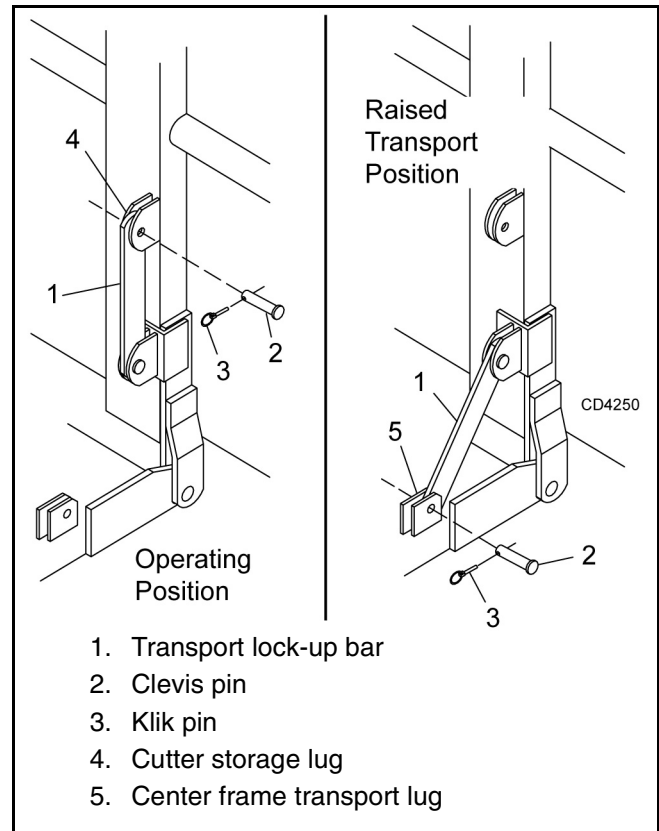

Figure 2. Lock-Up Bar

## **STORAGE**

### **⚠ WARNING**

- Do not disconnect hydraulic lines until machine is securely blocked or placed in lowest position and system pressure is released by operating valve levers.

When unhooking and parking the cutter, lower cutter head to ground. Place 12" blocks under both ends of the center frame. Lower center frame until 3-point arms are released and then disconnect. Be sure to disconnect PTO and hydraulic lines before moving tractor away.



# OWNER SERVICE

The information in this section is written for operators who possess basic mechanical skills. If you need help, your dealer has trained service technicians available. For your protection, read and follow the safety information in this manual.

## WARNING

■ For service and adjustments, lower center frame and cutter head to ground and disconnect cutter driveline from tractor PTO. Raise as needed for working room and securely block all sections of this equipment before working underneath. Blocking up prevents cutter dropping from hydraulic leak down, hydraulic system failures, or mechanical component failures.

■ When transporting the machine or working on the underside, attach lock-up bar as shown on page 16.

■ Make sure shields and guards are properly installed and in good condition. Replace if damaged.

■ Do not disconnect hydraulic lines until machine is securely blocked or placed in lowest position and system pressure is released by operating valve levers.

■ Operate tractor PTO at 540 RPM (1000 RPM on Q Series cutters). Do not exceed.

## CAUTION

■ Always wear relatively tight and belted clothing to avoid getting caught in moving parts. Wear sturdy, rough-soled work shoes and protective equipment for eyes, hair, hands, hearing, and head; and respirator or filter mask where appropriate.

## LUBRICATION

## WARNING

■ Lower cutter head to ground, shut off tractor engine and remove key before servicing.

Do not let excess grease collect on or around parts, particularly when operating in sandy areas.

Figure 3 shows the lubrication points. The chart gives the frequency in operating hours based on normal operating conditions. Severe or unusual conditions may require more frequent lubrication. Some reference numbers have more than one location; be sure to check number of points.

Use an SAE multi-purpose type grease. Be sure to clean fitting thoroughly before using grease gun.

Use a good quality 90W gear lube in gearboxes.

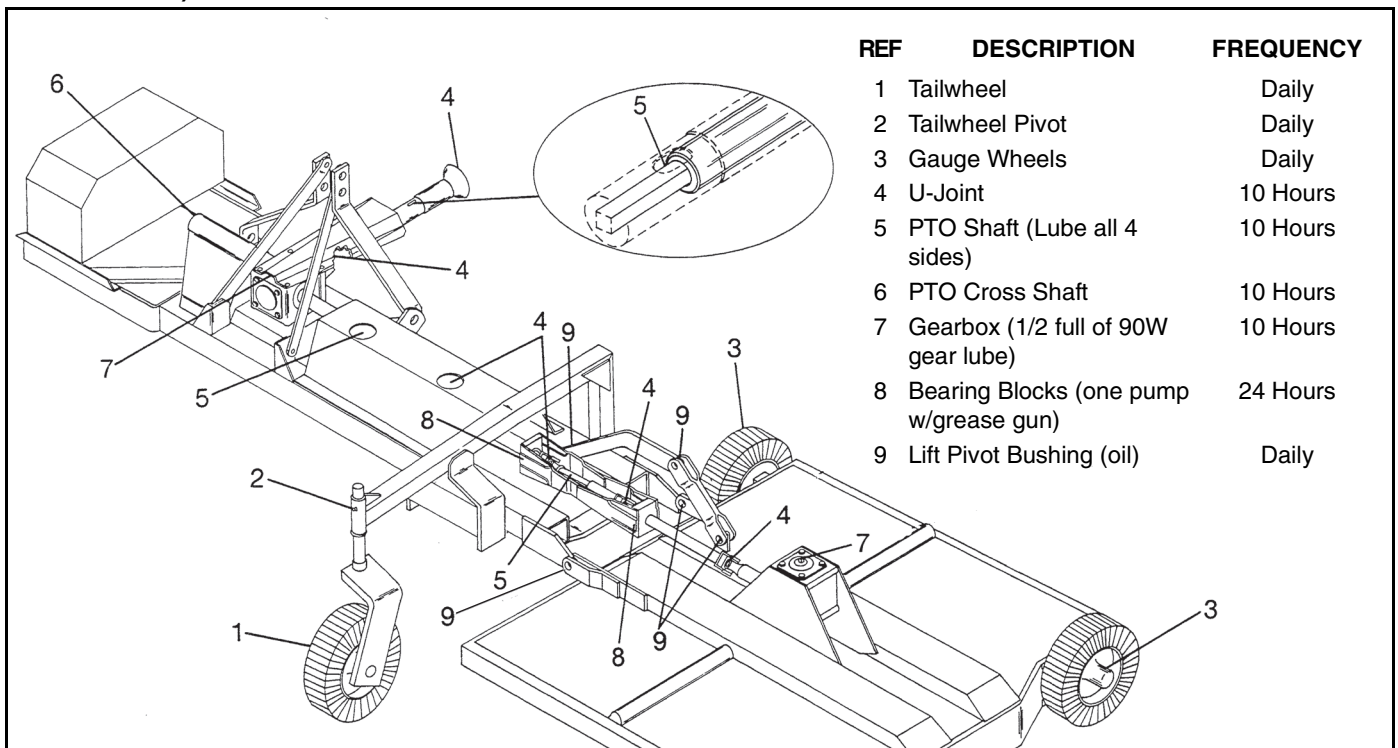

Figure 3. Lubrication Points

## **BLADE SERVICING**

### **NOTICE**

■ **Do not handle blades with bare hands. Careless or improper handling may result in serious injury.**

Raise wings and lock in up position. Inspect blades before each use to determine that they are properly installed and in good condition. Check to be sure blades are snug but still swivel on blade pin (see Blade Installation). Replace any blade that is bent, excessively nicked, worn or has any other damage. Small nicks can be ground out when sharpening.

### **Blade Removal**

Align crossbar and blade pin assembly with blade access hole in cutter frame. Remove bolt (1) and blade pin lock clip (2). Slide keyhole plate (3) out of blade pin groove and remove. Remove spacers and drive pin out of crossbar.

### **NOTICE**

■ **If blade is seized in crossbar and extreme force will be required to remove it, support crossbar from below to prevent gearbox damage.**

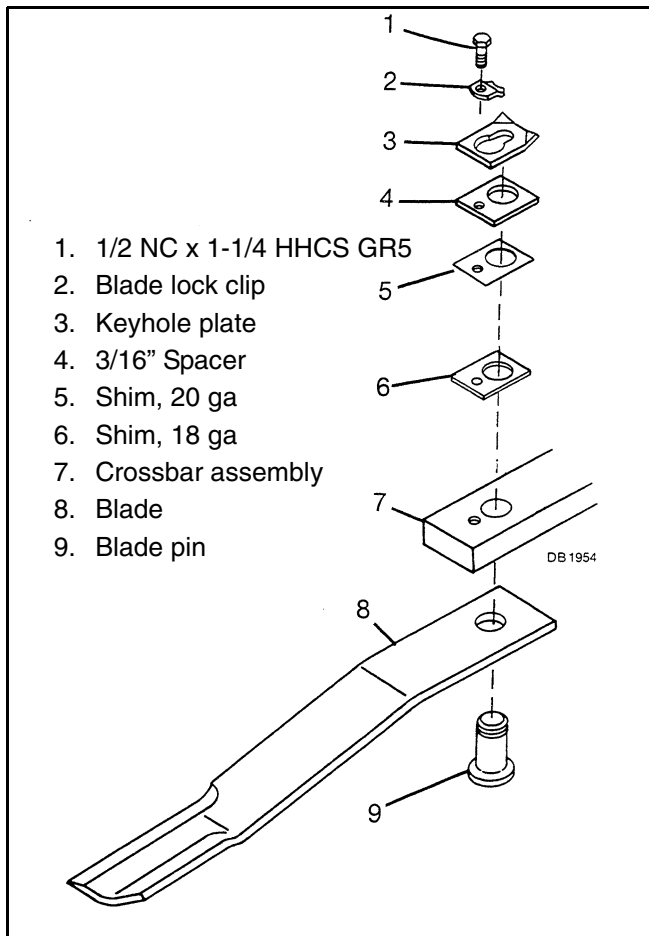

Figure 4. Blade Removal

## **Blade Installation**

Apply liberal coating of Never Seez<sup>®</sup> or equivalent to blade pin and crossbar hole. Make sure blade is offset away from deck with cutting edge toward direction of rotation. Install pin (9) through blade (8) and push up tightly against crossbar (7). Install as many spacers as possible, allowing enough space for keyhole plate (3) to slide into groove of blade pin. Keyhole plate (3) must be installed with formed ears up as shown. Insert lock clip (2) over keyhole plate and into blade pin groove and secure with bolt (1). When installation is complete, blade should be snug, but still swivel on pin without excessive force. Retain any spacers not used in shimming blade to be used when either installing new blade or when blade wear occurs.

### **NOTICE**

■ **Crossbar rotation is counter-clockwise when looking down on the cutter.**

■ **When sharpening blades grind each blade the same amount to maintain balance. When replacing blades, replace in pairs. Unbalanced blades will cause excessive vibration which can damage gearbox bearings. Vibration may also cause structural cracks in cutter housing.**

## **Blade Sharpening**

Always sharpen all blades at the same time to maintain balance. Follow original sharpening pattern. Do not sharpen blade to a razor edge, but leave at least a 1-1/16" blunt edge. Do not sharpen back side of blade.

## **SLIP CLUTCH ADJUSTMENT**

A slip clutch is designed to slip, protecting the gearbox and driveline, should the cutter strike an obstruction.

When a unit sets for a long period of time, such as winter storage, the clutch can rust and seize. When this occurs, loosen the spring tension and pry clutch plates apart. Engage PTO and slip clutch. Adjust clutch as specified.

The maximum the springs should be compressed on a standard clutch is 1-3/4" at dimension "A".

For a heavy-duty clutch and wing drive clutches, compress springs a minimum of 1-25/32" and a maximum of 1-13/16" at dimension "A".

If a clutch continues to slip with springs compressed to the maximum settings, check friction discs for excessive wear. Discs are 1/8" thick when new. Replace after 1/32" wear. (Minimum disc thickness is 3/32".)

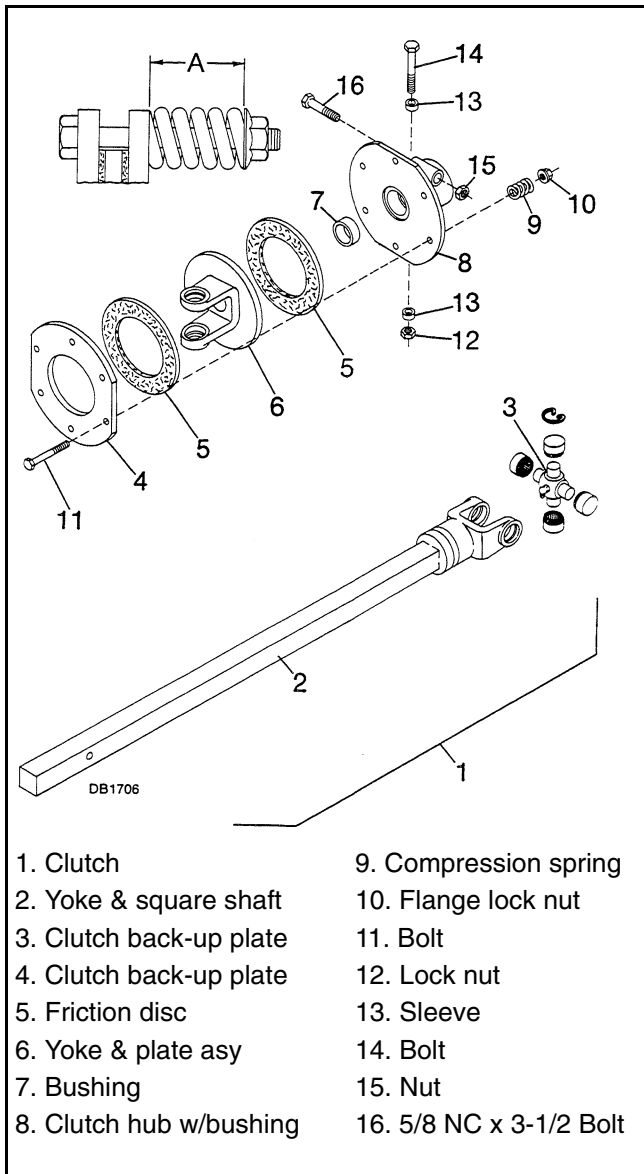

**Figure 5.** Slip Clutch Adjustment

- |                         |                         |
|-------------------------|-------------------------|
| 1. Clutch               | 9. Compression spring   |
| 2. Yoke & square shaft  | 10. Flange lock nut     |
| 3. Clutch back-up plate | 11. Bolt                |
| 4. Clutch back-up plate | 12. Lock nut            |
| 5. Friction disc        | 13. Sleeve              |
| 6. Yoke & plate asy     | 14. Bolt                |
| 7. Bushing              | 15. Nut                 |
| 8. Clutch hub w/bushing | 16. 5/8 NC x 3-1/2 Bolt |

## **CHAIN SHIELDING REPAIR**

Inspect chain shielding frequently. Replace any broken or missing chains as required.

## **CLEANING**

### **After Each Use**

- Remove large debris such as clumps of dirt, grass, crop residue, etc. from machine.
- Inspect machine and replace worn or damaged parts.
- Replace any safety decals that are missing or not readable.

### **Periodically or Before Extended Storage**

- Clean large debris such as clumps of dirt, grass, crop residue, etc. from machine.
- Remove the remainder using a low-pressure water spray.
  1. Be careful when spraying near scratched or torn safety decals or near edges of decals as water spray can peel decal off surface.
  2. Be careful when spraying near chipped or scratched paint as water spray can lift paint.
  3. If a pressure washer is used, follow the advice of the pressure washer manufacturer.
- Inspect machine and replace worn or damaged parts.
- Sand down scratches and the edges of areas of missing paint and coat with Woods spray paint of matching color (purchase from your Woods dealer).
- Replace any safety decals that are missing or not readable (supplied free by your Woods dealer). See Safety Decals section for location drawing.



# TROUBLE SHOOTING

<b>Problem</b>	<b>Possible Cause</b>	<b>Solution</b>
Does not cut	Dull blades	Sharpen blades.
	Worn or broken blades	Replace blades. (Replace pairs only.)
	Incorrect PTO speed	Be sure PTO speed is set at 540 or 1000 RPM. Make sure to check your unit's rated PTO speed.
	Ground speed too fast	Reduce ground speed.
	Drive not functioning (blades do not turn when PTO is running)	Check drive shaft connection. Check gearbox.
	Gearbox malfunction	Repair gearbox.
	Excessive clutch slippage	Adjust clutch.
Streaks or gives rugged cut	Broken or worn blades	Replace or sharpen blades.
	Ground speed too fast	Reduce ground speed.
	Excessive cutting height	Lower cutting height. (Note: Set height so blades do not frequently hit ground.)
	Excessive lush and tall vegetation	Recut at 90° to first pass.
Thrown objects	No shielding	Use chain shielding.
Excessive side skid wear	Running with skids continuously on ground	Set skids above ground.
Excessive clutch slippage	Clutch out of adjustment	Adjust clutch.
	Clutch discs worn	Replace discs.
	Blades hitting ground	Raise cutting height.
Vibration	Broken blade	Replace blades in pairs.
Excessive side skid wear	Running with skids continuously on ground	Use gauge wheels on cutter head.
Wing will not raise	Low oil	Add hydraulic fluid.

# DEALER SERVICE

The information in this section is written for dealer service personnel. The repair described herein requires special skills and tools. If your shop is not properly equipped or your mechanics are not properly trained in this type of repair, you may be time and money ahead to replace complete assemblies.

## **WARNING**

- **Lower cutter to ground, turn tractor engine off and remove key before performing any maintenance or service.**
- **When completing a maintenance or service function, make sure all safety shields are in good condition and properly installed before placing cutter in service.**

## **CAUTION**

- **Always use personal protection devices such as eye and ear protection when performing maintenance and service functions.**

## **GEARBOX MAINTENANCE**

Read this complete section before any repair. Many steps are dependent on each other.

Always maintain gearboxes half full of 90W gear lube. Be sure proper vent plugs are installed in wing gearboxes.

Troubleshooting is an important part of gearbox maintenance. Check for leakage and bad bearings.

Leakage may be caused by a vent plug not venting. The vent plug has an internal relief valve set at approximately 5 psi. Remove plug, apply low air pressure to bottom of plug, and be sure it is venting out the top. Operating gearboxes over half full of gear lube may also cause seals to leak. Also check for cracks in housing. If either of these conditions exists, correct them, clean up area where leakage was evident, put cutter back into service and check area for leakage.

Bearing misadjustment or failure is indicated by noise and excessive side and end play in gear shafts. If noted, readjust bearings or disassemble and inspect bearings. Excessive end play in vertical shafts may also indicate crossbars are not properly shimmed.

Leakage may occur at these points: top cover, vertical or horizontal seals and at the square ring between side housings and gearbox.

Leakage is a very serious problem and must be corrected immediately.

Leakage at the horizontal seal, top cover, or between the housing and side covers and side gear housings can be corrected without removing gearbox from cutter.

The sealant recommended for gearbox repair is Permatex Aviation 3D Form-A Gasket<sup>®</sup> or equivalent.

## **Leakage Repair**

Repair top cover leakage by removing and cleaning top cover and top of gearbox.

Use care to prevent foreign material from entering the gearbox. Apply a thin coat of Permatex to top of gearbox and cover bolts. Install a new gasket and replace cover.

Repair horizontal seal or leakage between side housing and gearbox, remove top cover and siphon gear lube from box. Remove the leaking seal and replace (refer to Seal Installation). Use care to prevent rolling seal lip under. Repair leakage between side housing and gearbox by removing housing and replacing square O-ring. Be sure to reinstall shims when installing side housing.

## **Seal Installation**

Proper seal installation is important. An improperly installed seal will leak and could result in gearbox failure.

Clean area in housing or cap where seal outer diameter seats and apply a thin coat of gasket sealant. Inspect gear shafts and sleeves. Pay specific attention to areas where seals seat. Check for cracks, grooves, nicks or bumps. Replace housing, shaft or sleeve if damage cannot be repaired by resurfacing with emery cloth.

Lubricate seal lip and carefully guide over sleeve or shaft using a blunt tool such as a letter opener. Be careful not to roll seal lip under. Do not use a knife blade as it will nick and ruin seal.

Place seal squarely on housing (spring-loaded lip toward inside of gearbox). Select a seal driver, a piece of pipe or tubing with an OD that will set on outside edge of seal but will clear housing. A driver that is too small will bow seal cage and ruin seal.

Carefully press seal into housing, preventing distortion to metal seal cage. Seat vertical seal firmly and squarely against machined surface and horizontal seal flush with housing.

Distortion to seal cage or damage to seal lip will cause seal to leak. Remove and replace seals damaged in installation.

## Removing Gearbox from Cutter

Remove safety shielding. Remove top cover and siphon gear lube from gearbox. Remove drive lines. Remove crossbar (see Crossbar Removal). Remove gearbox from cutter.

## Gearbox Assembly - Cutter Head

Press cups into main housing until they seat against machined shoulders. Press bearings onto shafts until they seat against machined surface next to gear.

Install vertical shaft into gearbox housing, and horizontal shaft into horizontal housing, then press bearings on with sleeve until all free play is removed (similar to adjusting front wheel bearings on an automobile). Check by spinning housing. It should turn freely.

If bearings are too tight, hold housing and rap gear shaft with a lead hammer. Do not leave bearings adjusted too tight. Proper adjustment is essential to good bearing life.

Install the vertical and horizontal shaft seals.

After seating the seal on the vertical shaft, depending on when the gearbox was manufactured there are two options:

1. Place a 1-5/8 ID x 2-31/32 OD washer over the shaft and into the neck of the gearbox housing. You will need to tap this washer in place until the gearbox is installed on the cutter.
2. Press a 1-5/8 ID x 2-3/4 OD washer and a washer retainer firmly against the seal.

Bearing adjustment on the vertical shaft is set with the sleeve and maintained with proper crossbar shimming.

Bearing adjustment on the horizontal shaft is set with the sleeve and maintained by tightening a large hex nut against the sleeve, installing a dowel plug in the nut and tightening a set screw against the dowel. Prior to installing the nut, clean the threads on the nut and the shaft and apply two drops of Loctite on the threads.

## Horizontal Housing Installation

With the housing assembled, place the square O-ring on the housing and install to gearbox, tighten the four bolts evenly. Turn the gears against each other to determine how they rotate. They should turn freely. If there is a spot where they turn hard, install a gasket between the horizontal housing and gearbox.

## Gearbox Assembly - Input

Press cups into main housing until they seat against machined shoulders. Press bearings onto shafts until they seat against machined surface next to gear.

Install input shaft into gearbox housing, then press bearing on with sleeve until all free play is removed

(similar to adjusting front wheel bearings on an automobile). Check by spinning housing. It should turn freely.

If bearings are too tight, hold housing and rap gear shaft with a lead hammer. Do not leave bearings adjusted too tight. Proper adjustment is essential to good bearing life.

Install input shaft seal.

Bearing adjustment on the input shaft is set with the sleeve and maintained by tightening a large hex nut against the sleeve, installing a dowel plug in the nut, and tightening the set screw against the dowel. Prior to installing the nut, clean the threads on the nut and the shaft and apply two drops of Loctite on the threads.

## Output Shaft Installation

Place the square O-ring on the housing and install to gearbox, tightening the four bolts evenly. Turn the gears against each other to determine how they rotate. They should turn freely without bearing end play. If there is a spot where they turn hard, install a gasket between housing and gearbox. If there is bearing end play, remove gasket.

Install seals on both ends of shaft.

## CROSSBAR

### Removal

For crossbar removal, it is necessary to gain access to bottom side of cutter. Raise cutter and securely block up. You may use either puller screw (6) or a small hydraulic jack to remove crossbar. See Figure 6.

Loosen bolts on crossbar clamp. Remove bolt retaining washer by prying washer up and breaking weld. Remove washer and bolt. Remove blades from crossbar (see page 18). Assemble clevises (1) to each end of crossbar, utilizing blade pins, spacers, keyhole plates and blade pin clips.

Position tube assembly (5) with threaded nut toward crossbar. Install pad assembly (4) in nut on square tube assembly.

Bolt square tube assembly to the clevises using 5/8" x 4-1/2" bolts (2). Insert puller screw assembly (6) into square tube assembly (5) and tighten against pad assembly (4) an gear shaft as shown. For best results, strike head of puller screw with a sledge hammer while tightening screw with a wrench. If crossbar has been installed with Loctite, it may be necessary to apply heat (greater than 500°F) to crossbar to break Loctite bond.

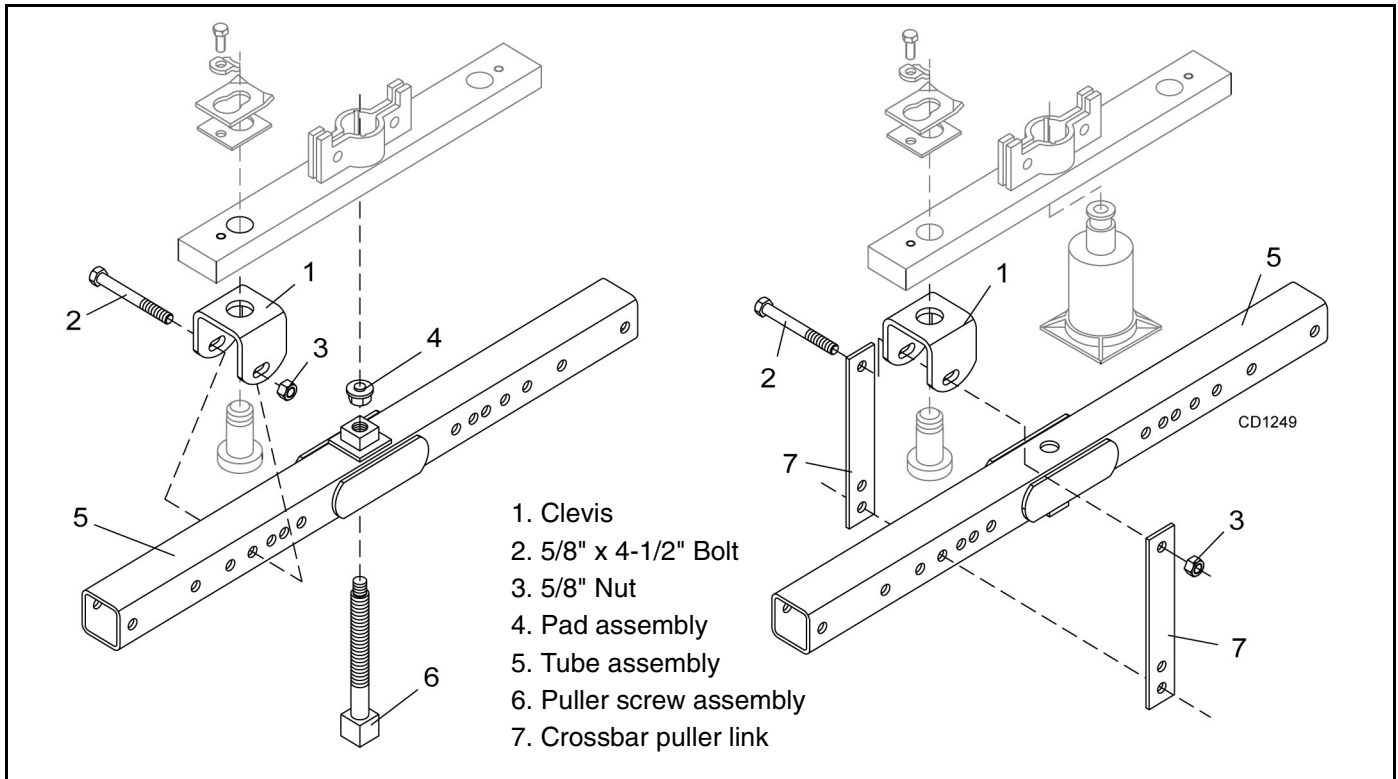

**Figure 6.** Crossbar Puller

To remove crossbar with hydraulic jack, install the clevis (1) using the blade pin spacers, keyhole plates and bolts to each end of crossbar. Position square tube (5) with threaded nut portion down.

Attach square tube to the clevises using crossbar puller links (7) to space it away from crossbar. Place hydraulic jack on square tube so end of jack presses against end of gearbox shaft. Slowly apply force with hydraulic jack.

**NOTE:** Hydraulic jack will not operate if tipped more than 90°. It may be necessary to apply heat to break Loctite bond on crossbar. Use caution to prevent bending crossbar when using either removal method.

### Installation

The anti-wrap washer (2) was added as an inline production change. Your cutter may not be equipped with the anti-wrap washer (2). It is designed to minimize foreign material wrapping around the gear shaft and causing seal damage. You may order an anti-wrap kit for installation on your cutter.

Select the 1-5/8" ID x 2-5/16" OD x 7 GA washer (1) from the shim pack and install as shown. Install the anti-wrap washer (2) next to the 7 GA washer as shown.

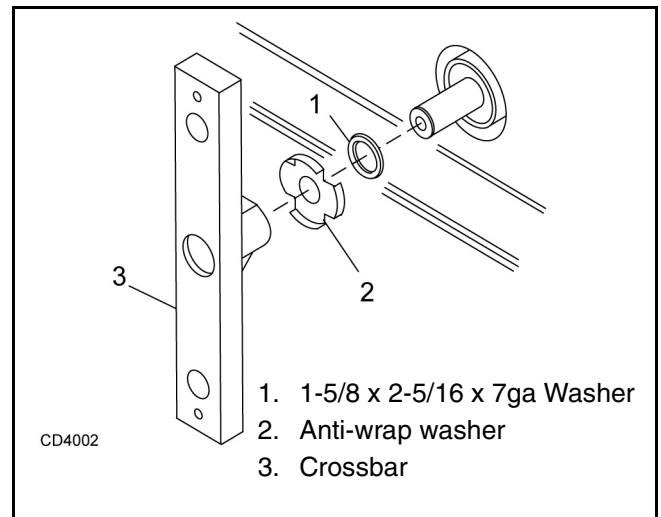

**Figure 7.** Anti-Wrap Washer Installation

### Shimming

A properly shimmed crossbar is essential to obtain good gearbox bearing life. Make sure the gearbox vertical shaft bearing adjustment is correct. Bearings should be just tight enough to remove all free play. You should feel a slight drag caused by the seals, but not enough drag to indicate pre-loaded bearings.

## NOTICE

■ Incorrectly shimmed crossbars can cause costly damage to bearings and gearboxes. Follow these steps to obtain a properly shimmed crossbar.

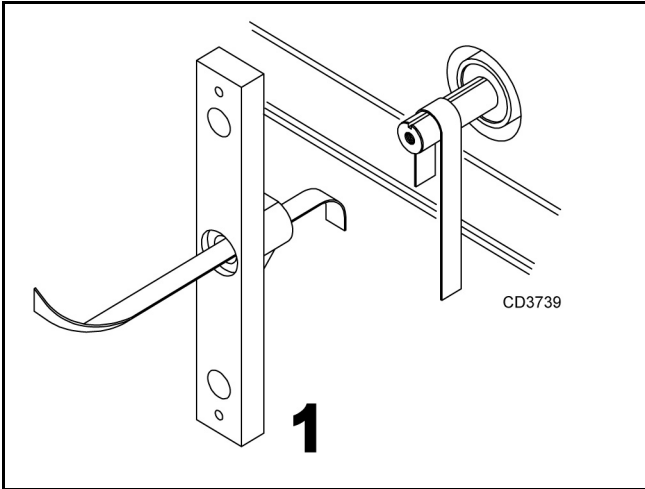

Figure 8

1. Using emery cloth (220 or finer), remove surface rust, Loctite and foreign material from gearbox vertical shaft and hole in crossbar.

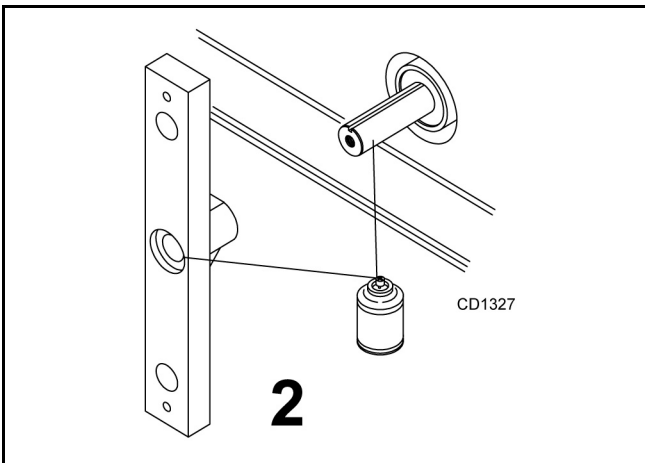

Figure 9

2. Apply Locquic® primer to gearbox vertical shaft and hole in crossbar. Wipe off with clean cloth and reapply. This reduces Loctite curing time. Do not reapply blue Loctite until all solvent smell has gone.

**NOTE:** Omit step 2 when installing a clamp-type crossbar.

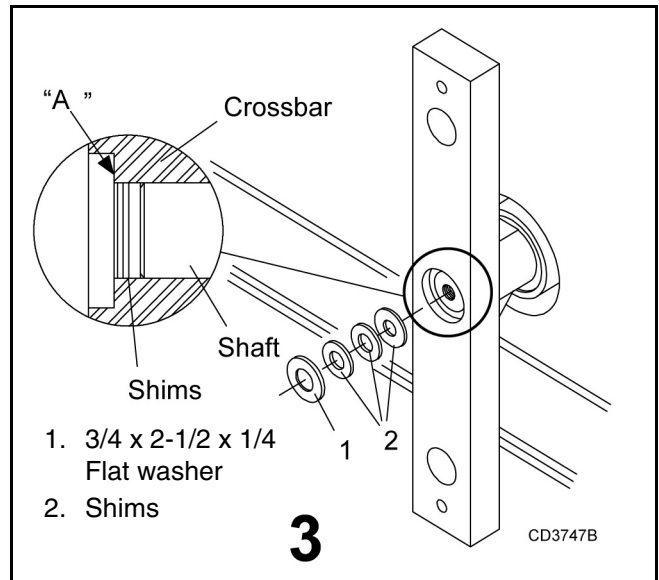

Figure 10

## NOTICE

■ Failure to accomplish step three as outlined will result in an improperly shimmed crossbar and gearbox bearing failure.

3. Install crossbar on gearbox vertical shaft without key in keyway. Make sure crossbar is seated firmly against washer covering oil seal in gearbox neck. Do not drive crossbar on vertical shaft. If crossbar will not install easily, repeat step one until it will.

Select shim pack. Add shims until they are level with shoulder in crossbar (point A).

The washer (1) should only be used if using anti-wrap washer.

Press shims in place very tightly and feel to see if more shims are needed. When you reach the point where adding one more shim will extend above crossbar shoulder, do not add that shim.

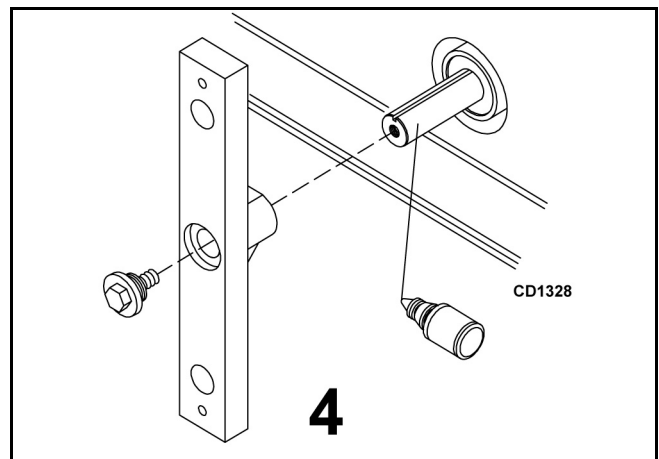
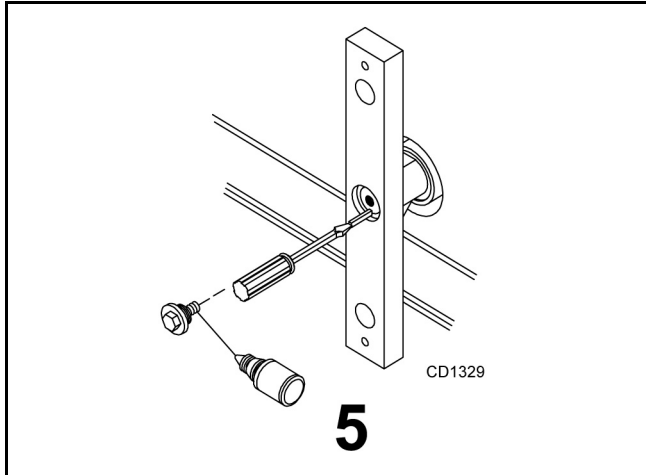

Figure 11



4. When you are certain you have correctly determined the proper shim pack, remove crossbar and apply blue Loctite retaining compound to vertical shaft. When fit between shaft and crossbar is tight, use Loctite sparingly. When fit is loose, completely coat the shaft.

**NOTE:** Do not apply Loctite to vertical shaft when installing a clamp type crossbar.

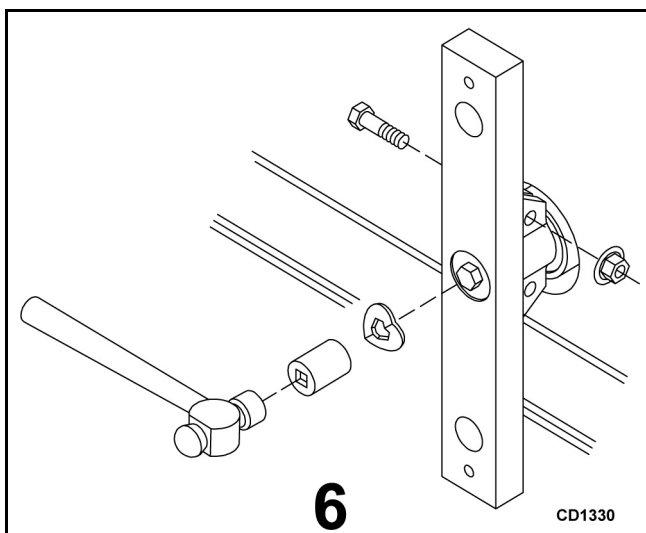

**Figure 12**

5. Install crossbar on vertical shaft and push keys into keyway with screwdriver. Do not drive key in with a hammer, as this could loosen vertical shaft bearings. Clean crossbar bolt threads and apply a few drops of red Loctite.

Install 1/4" thick washer and shim pack, selected in step three, on bolt. Install bolt into vertical shaft and torque to 300 lbs-ft.

With crossbar installed, recheck gearbox bearings for excessive drag or presence of free play. If either excessive drag or any free play is detected, repeat step three.



**Figure 13**

6. When installing a clamp-type crossbar, install clamp bolts and torque to 85 lbs-ft.

Install crossbar block lock over bolt head. Place a socket over bolt and drive in lock until it is completely flat.

**NOTE:** If drive-in type crossbar bolt lock is not available, the weld-on lock may be reused. Install lock over bolt head and weld it to the crossbar with a 1/2" long weld.

**NOTICE**

■ Attach welder ground directly to crossbar. Failure to do so can ruin gearbox bearings.

**UNIVERSAL JOINT REPAIR**

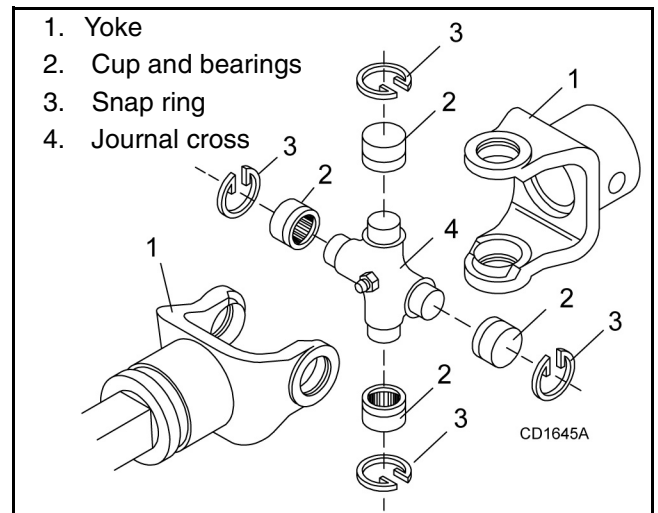

**Figure 14. U-Joint Exploded View**

**U-Joint Disassembly**

1. Remove external snap rings from yokes in four locations as shown in Figure 15.

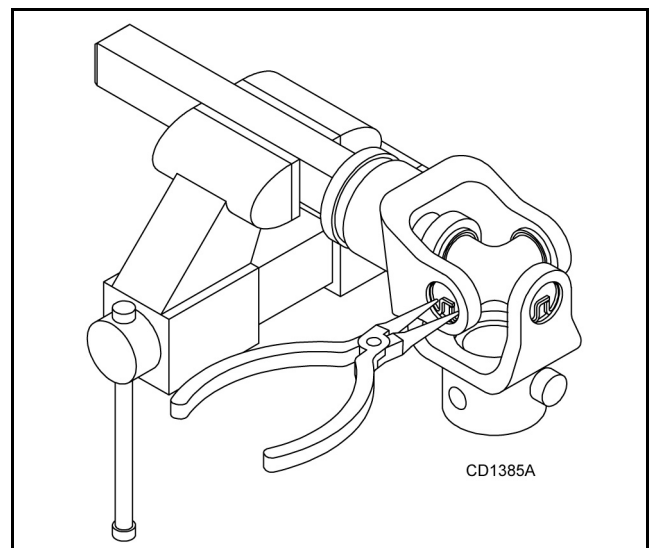

**Figure 15**

2. With snap rings removed, support drive in vise, hold yoke in hand and tap on yoke to drive cup up out of yoke. See Figure 16.

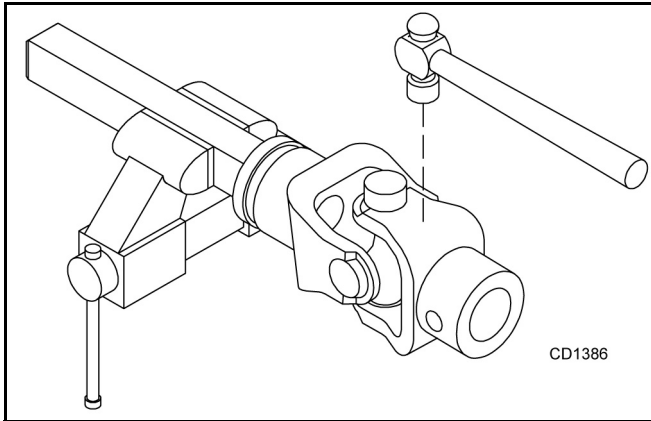

**Figure 16**

3. Clamp cup in vise as shown in Figure 17 and tap on yoke to completely remove cup from yoke. Repeat step 2 & step 3 for opposite cup.

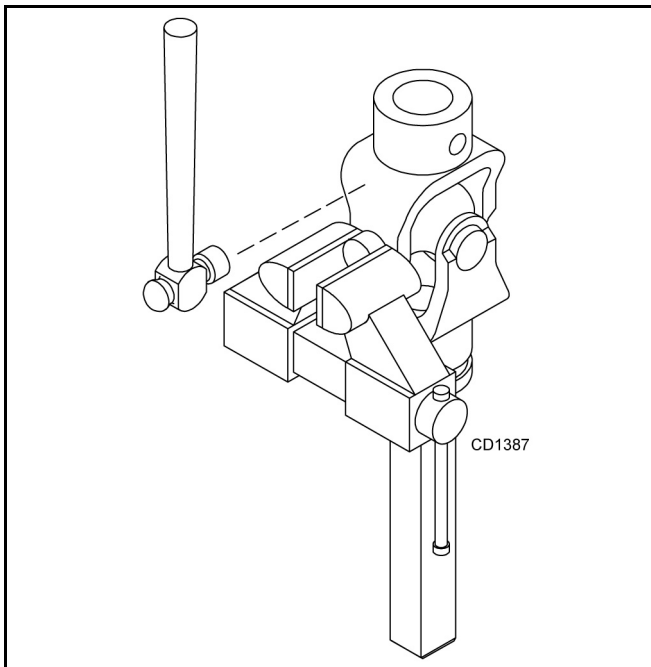

**Figure 17**

4. Place universal cross in vise as shown in Figure 18 and tap on yoke to remove cup. Repeat step 3 for final removal. Drive remaining cup out with a drift and hammer.

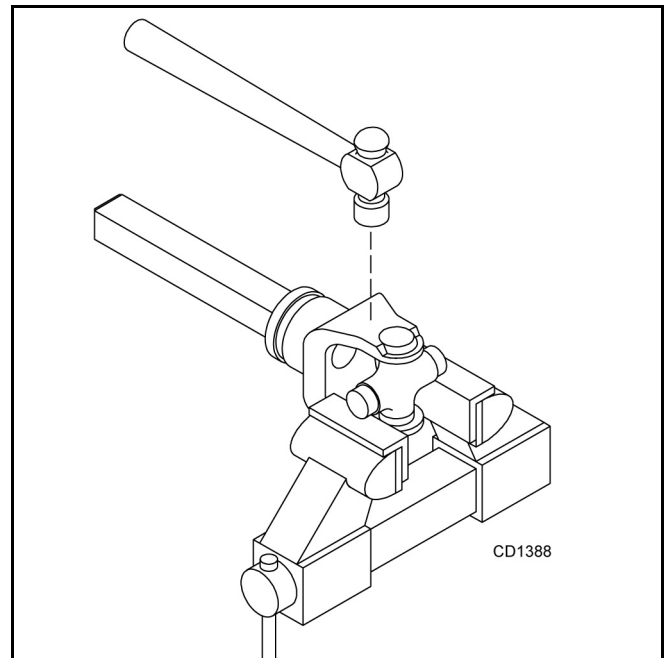

**Figure 18**

## U-Joint Assembly

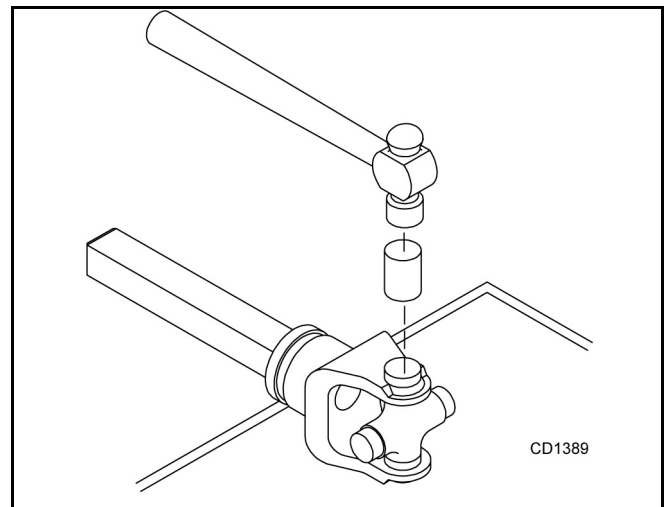

**Figure 19**

1. Place seals securely on bearing cups. Insert cup into yoke from outside and press in with hand pressure as far as possible. Insert journal cross into bearing cup with grease fitting away from shaft. Be careful not to disturb needle bearings. Insert another bearing cup directly across from first cup and press in as far as possible with hand pressure.
2. Trap cups in vise and apply pressure. Be sure journal cross is started into bearings and continue pressure with vise, squeezing in as far as possible. Tapping the yoke will help.
3. Seat cups by placing a drift or socket (slightly smaller than the cup) on cup and rap with a

hammer. See Figure 19. Install snap ring and repeat on opposite cup.

4. Repeat step 1 & step 2 to install remaining cups in remaining yoke.
5. Move both yokes in all directions to check for free movement. If movement is restricted, rap on yokes sharply with a hammer to relieve any tension. Repeat until both yokes move in all directions without restriction.

## **SPRING-LOADED WHEEL YOKE ADJUSTMENT**

Tighten elastic stop nuts on spring bolts until 1/4" of bolt thread extends through nut.

## **1-SPOOL, 3-WAY VALVE**

This valve is an extremely closely-fitted unit. Great caution should be taken to keep all dirt and impurities out of it. Any foreign matter could ruin sealing surfaces.

### **Open-Center or Closed-Center**

This valve can be used with tractors having either a closed-center or open-center hydraulic system. The valve, as shipped, is ready for use with open-center systems. To adapt it for use with closed-center systems, remove the plug adjacent to the outlet port and replace with the power-beyond sleeve and plug included in box of parts. Also, reset pressure relief valve to a closed position by removing cap (45) and turning adjustment screw (43) all the way in. Replace cap (45).

In operation, an open-center system allows oil to flow freely through valve when all spools are in neutral. It is used on most tractor systems. The closed-center valve is blocked, allowing no oil to circulate when spools are in neutral. This system is used on late model John Deere 3010, 4010, etc., Ford model 6000, and MF models 1100 and 1130.

## **Operation**

The valve spool is equipped to operate a single-acting cylinder and has a float position detent. The spool will automatically return to neutral when not in detent. With spool in neutral, cylinder will be held in position.

## **Servicing**

### **Spool Sticking**

Any tendency of spools to stick in position is usually caused when mounting bolts are pulled down too tight, or the valve is mounted on an uneven surface. Also, excessive pressure will make spools stick.

### **Lift Check Service**

The load lift checks are used to prevent a load from dropping prior to starting to raise when the spool is being moved slowly to the raised position from neutral. If these checks leak by, so that the load does not hold properly, remove lift checks, inspect the check and seats, and replace if necessary.

### **Spool Removal**

The spool is selectively fitted in body and cannot be interchanged or exchanged. However, it may be removed to replace seals, but it is not necessary that it be removed completely. To replace seals on any spool, remove handle and snap ring, then push spool far enough out back of valve to expose V-cup seal on handle end. Remove and replace with new seal V-cup facing inward. Remove retaining screw from other end of spool. Slide spool through the new seal, being careful not to roll over the edge. Slide forward far enough to expose the seal in back of valve. Replace it the same way, slip spool back into its normal position, and reassemble.

### **Fitting leakage**

Use a thread sealant on all fittings to prevent leakage.



# DEALER CHECK LISTS

## PRE-DELIVERY CHECK LIST

(DEALER'S RESPONSIBILITY)

Inspect the equipment thoroughly after assembly to ensure it is set up properly before delivering it to the customer.

The following check lists are a reminder of points to inspect. Check off each item as it is found satisfactory or after proper adjustment is made.

- \_\_\_ Check that all safety decals are installed and in good condition. Replace if damaged.
- \_\_\_ Check that shields and guards are properly installed and in good condition. Replace if damaged.
- \_\_\_ Properly attach implement to tractor and make all necessary adjustments.
- \_\_\_ Check all bolts to be sure they are tight.
- \_\_\_ Check and grease all lubrication points as identified in "Service".
- \_\_\_ Check that blades have been properly installed.

## DELIVERY CHECK

(DEALER'S RESPONSIBILITY)

- \_\_\_ Instruct customer how to lubricate and explain importance of lubrication.
- \_\_\_ Point out the safety decals. Explain their meaning and the need to keep them in place and in good condition. Emphasize the increased safety hazards when instructions are not followed.
- \_\_\_ Present Operator's Manual and request that customer and all operators read it before operating equipment. Point out the manual safety rules, explain their meanings and emphasize the increased safety hazards that exist when safety rules are not followed.
- \_\_\_ Show customer the safe, proper procedures to be used when mounting, dismounting, and storing equipment.
- \_\_\_ Point out all guards and shields. Explain their importance and the safety hazards that exist when not kept in place and in good condition.



# ASSEMBLY

## DEALER SET-UP INSTRUCTIONS

Assembly of this cutter is the responsibility of the Woods dealer. It should be delivered to the owner completely assembled, lubricated, and adjusted for normal cutting conditions.

The cutter is shipped partially assembled. Assembly will be easier if aligned and loosely assembled before tightening hardware. Recommended torque values for hardware are located in the Bolt Torque Chart on page 54.

### DANGER

■ Full chain shielding must be installed when operating in populated areas or other areas where thrown objects could injure people or damage property.

- If this machine is not equipped with full chain shielding, operation must be stopped when anyone comes within 300 feet (92 m).
- This shielding is designed to reduce the risk of thrown objects. The mower deck and protective devices cannot prevent all objects from escaping the blade enclosure in every mowing condition. It is possible for objects to ricochet and escape, traveling as much as 300 feet (92 m).

### WARNING

■ Make sure spring-activated locking pin or collar slides freely and is seated firmly in tractor PTO spline groove.

■ Operate tractor PTO at 540 RPM (1000 RPM on Q Series cutters). Do not exceed.

### CAUTION

■ Always wear relatively tight and belted clothing to avoid getting caught in moving parts. Wear sturdy, rough-soled work shoes and protective equipment for eyes, hair, hands, hearing, and head; and respirator or filter mask where appropriate.

## Drive Shaft Installation

### Cut Drive Shields

**NOTE:** The driveline shielding must be cut to dimensions given before installing of front drives.

1. Remove approximately 1-inch of material from bell shield so it will not interfere with slip clutch during operation. See Figure 20.

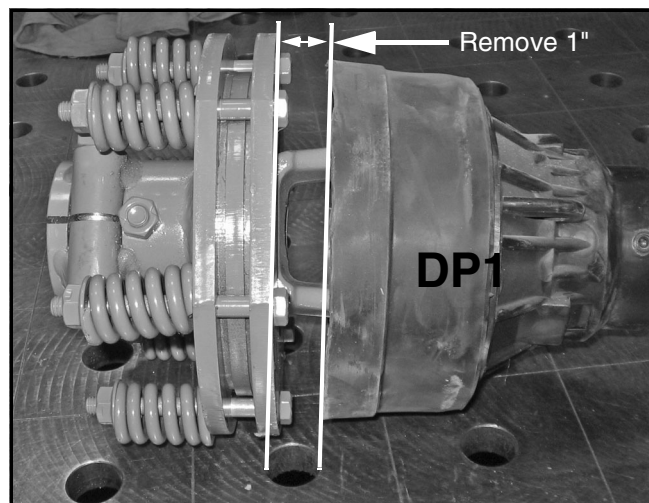

Figure 20. Slip Clutch Bell Shield

2. Cut slip clutch drive shield to 8-3/4" as shown in Figure 21.



Figure 21. Slip Clutch Drive Shield

3. Cut front half of drive shield to 6-1/2" for standard length drive as shown in Figure 22. Cut optional long drive shield to 13-1/4".

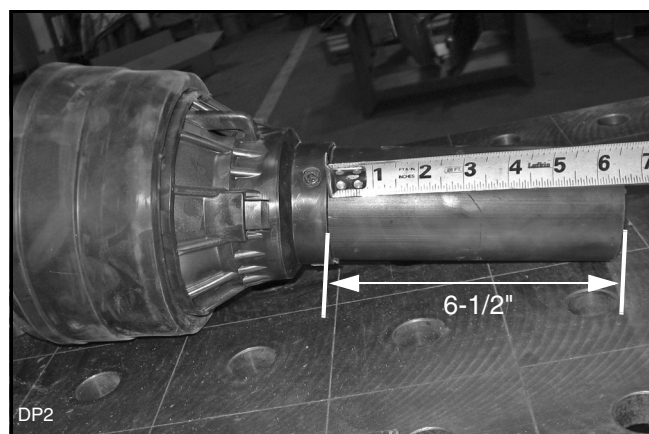

Figure 22. Front Drive Shield, Standard Drive Shown

## Install Drive Shaft

See parts drawing on page 36.

Slide clutch and square shaft assembly onto gearbox shaft, using two 1/4" keys. Secure with 7/16 hex bolt through cross hole and tighten securely. Slip tubular outer drive assembly (19) over square shaft until closed. Install shield (42) on top of gearbox and secure with 5/8 NC lock nuts (76).

## Mounting A-Frame on Center Frame

See parts drawing on page 36.

Attach A-frame half (16) to inside surface of mounting arms, using Category 2 mounting pin (14). Secure with 1-1/8 NF slotted hex nut (95). After assembling both sides of A-frame, assemble clevis pin (82) through top hole of A-frame halves. Secure clevis pin with two cotter pins (56).

Secure A-frame brace bars (6) to outside of attaching lugs with two 3/4 x 2 hex head cap screws, lock washers and nuts. Attach top of brace bar to A-frame, using 3/4 x 4-1/2 hex head cap screw. Be sure brace bars and sleeve (89) are installed in bottom hole and between A-frame halves. Tighten all bolts securely. Torque hitch pin nuts to 300 lbs-ft and secure with cotter pins (56).

Connect top link and adjust so frame rides approximately level. Connect front drive shaft to PTO shaft of tractor so that lock pins snaps into groove of PTO shaft. Be sure drive has adequate engagement and does not bind or bottom in any position. Optional longer drive is available.

## Lift Cylinder Installation

See parts drawing on page 36.

Remove shield (26). Connect lift arm (10) by using a 1-1/8 x 7" clevis pin (94) through frame and secure with a 1/4 x 1-3/4 cotter pin (57). Be sure pin is installed pointing forward. If installed pointing backwards, the end will interfere with and damage drive shaft.

Install cylinder butt end to lug located on the cross channel of center frame by using pin furnishing in butt

end of cylinder. Discard pin in rod end and replace with 1 x 3" clevis pin (93) found in bag of parts. Remember to install pin pointing forward or damage to drive shaft will result. Connect rod end to lift arm by using the 1 x 3" clevis pin (93). Secure with a 1/4 x 1-1/2 cotter pin (56). Be sure sleeve (91) is installed in lift arm as shown and that the check valve plug (8) in base of cylinder is on bottom side and rod end fitting is on top.

Install a 1/2 x 1/4 reducing bushing followed by a 1/4" 90° swivel street 1/16 restrictor elbow in end of cylinder. Use pipe thread compound and tighten securely. Position with port pointing inward.

Connect 1/4 x 90" long hydraulic hose (20) to swivel fitting. Run hose through loop provided on mounting arm and using rubber binding strap, attach hose to A-frame where it will stay clear of slip clutch. The front end of this hose must be connected to tractor hydraulic system. If the tractor has a valve, or if you are using the control valve (35), it must be connected as shown.

It is desirable to connect the hose through a quick coupler, if provided, on the tractor. A 1/2 x 1/4 reducing bushing is provided to adapt to the tractor quick coupler.

If a Woods valve is used, connect end of this hose to quick coupler provided with valve. To other end of quick coupler, connect the 36" hydraulic hose furnished with valve. Connect hose to top port of valve.

## Attaching Cutter Head to Center Frame

Position center frame attaching lugs between center plates of cutter. Install 3/4 x 1-1/8 x 5/8" bushing (88) in center plates of cutter in four places. Also install two bushings (98) in lugs of center frame. Secure with two 3/4 x 3" hex head cap screws (80) and a flat washer (87), both under head and outside. NOTE: Be sure bolt is installed from inside out as shown on page 36. Add 3/4" hex lock nut (86) and torque to 300 lbs-ft.

## Lift Link Installation

Connect clevis lift link (21), page 38, between lift arm and cutter frame as shown, using two 1 x 2-1/2" clevis pins (60) and cotter pins (46).

## Side Drive Installation (Figure 23)

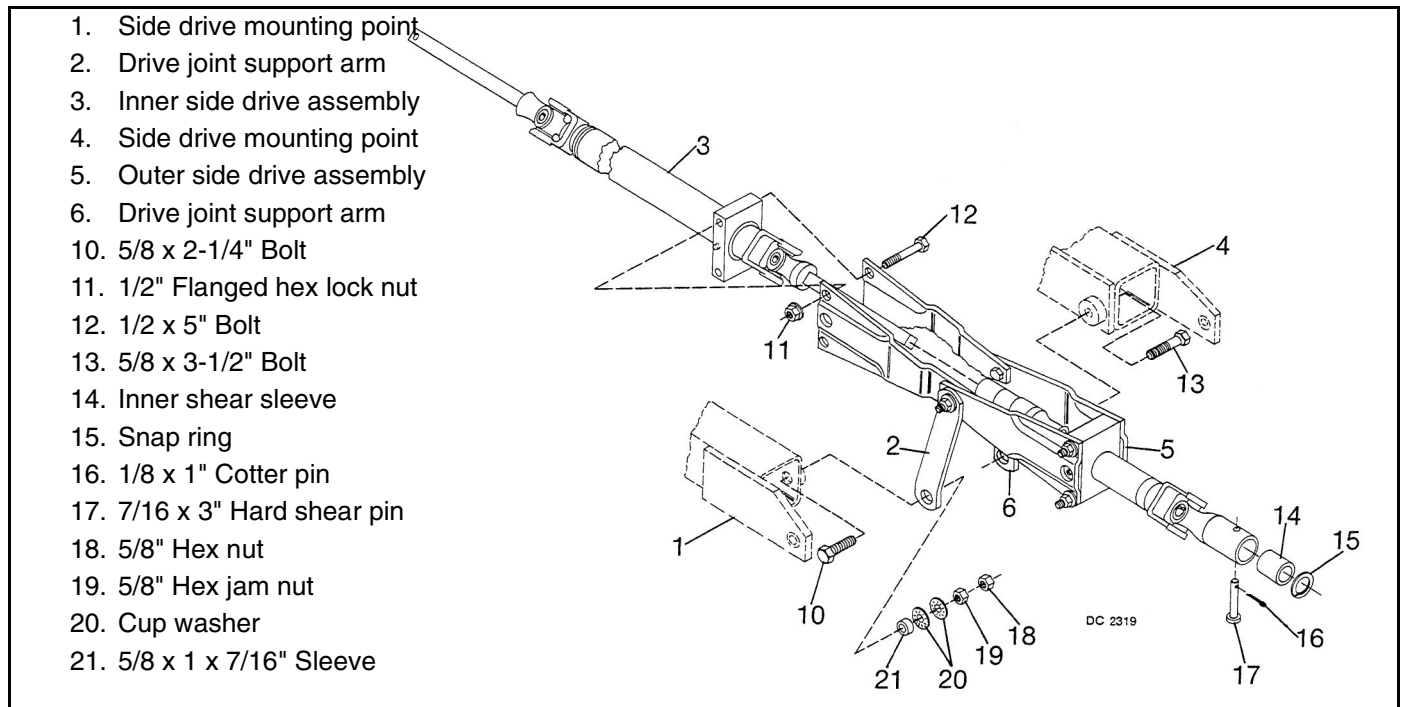

**Figure 23.** Side Drive Installation

Assemble inner drive assembly (3) into outer drive assembly (5). Check to ensure drive shaft and U-joints are indexed properly. The small pin on end of square shaft should mate with outer drive for proper installation. Place offset plates of side drive assembly over bearing block of inner drive assembly, and attach with bolts (12) and lock nuts (11). Do not tighten hardware at this time.

Install inner shear sleeve (14) into end of U-joint sleeve and work snap ring (15) into groove to retain shear sleeve (14).

Install inner drive (3) into gearbox on center section. With keys in place in cutter head gearbox shaft, slide outer drive onto shaft, align hole in inner shear sleeve, gear shaft and U-joint sleeve and install hard shear pin (17). Retain with cotter pin (16).

Attach drive joint support arms (23 & 6) to side drive mounting points (1 & 4). Insert bolt (10) through hole in mounting point (1), place sleeve (21) over bolt, and install cup washers (20) with cups toward sleeve. Install this assembly through support arm (2), apply Loctite) to bolt, then install jam nut (19) and tighten. Secure with nut (18).

Repeat this procedure for support arm (6), using bolt (13).

Insert grease zerk into threaded hole on end cap of drive shaft shield. For location, see page 36, item 99. Tighten as required.

## Side Shield Installation

Refer to parts drawing on page 36.

Install inner drive shield (49) over outside of plates on outer drive (1). Tighten all hardware. Attach cylinder and drive shield (26) with four self-tapping screws.

Install drive shaft shield (5) over end of drive shaft that protrudes through the center section gearbox with self-tapping screws.

## Cutter Head Gearbox Shield Installation

Refer to page 38.

Remove four gearbox cover bolts. Place shield (34) over gearbox and reinstall bolts.

## Blade Installation

Raise cutter.

The cutter blades are shipped separately.

Remove bolt, spacer plug, keyhole plate and spacer plates. Drop the blade pin out. Discard shipping spacer.

Install pin upward through blade. Be sure blade is right side up. Reinstall pin. Replace spacers and keyhole plate. If the fit is too tight, one of the thin spacers may be removed. Reinstall spacer plug and bolt. It is not necessary to torque the bolt excessively.

## Tire and Skid Assembly Installation

Refer to parts drawing on page 38.

The mower is shipped with skids assembled to rear corners.

If tires and wheels are used, assemble the solid laminated tire (24) to cutter frame with one lock washer (62), and secure with one 1" NF hex nut (61).

If skids are used instead of wheels, install two 3/4 x 2-1/4" hex head cap screws (57), 3/4" standard flat washers (58), and a 3/4 x 1 x 1-7/8" sleeves (56). Secure with a 3/4" NC hex lock nuts (59).

Tires or skids may be adjusted up or down for desired mowing height. Cutter should be adjusted so rear outer skid does not carry any weight under normal conditions as it encounters considerable side slipping action when turning. The inner side skid should be adjusted to prevent cutter from scalping, but so it does not ride on the ground in normal mowing.

Adjust front skids so they prevent scalping and so they will carry cutter when the tractor goes through a low spot. When skids are used, the weight of the cutter should be carried on the tractor and not on skids or rapid wear will result. After desired height has been selected, bolt left and right wheel guards in place. Secure with 1/2 x 1-3/4" carriage bolt and 1/2" flanged lock nut.

## Lubrication

Fill both center and cutter gearboxes half full of 90 EP gear lube or similar transmission oil. These boxes are sealed. If there is no leakage, only occasional oil checks are required.

Check for leaks in the hydraulic system. On cutter gearbox, remove top plug and replace with special vented pipe plug from box of parts.

## Checking the Machine

Raise and lower the 3-point hitch very carefully, and be sure drive shaft does not tend to bottom in any position, and that it does not come apart or get too loose in any position. If the drive shaft is too short, there are alternate tubular drive units available.

Raise and lower cutter frame very carefully, being sure none of the bolt heads interfere with drive linkage, etc., and that drive shaft slides freely and works properly. Cutter should raise to approximately a vertical position.

Start cutter slowly and be sure blades don't interfere with anything. The drive must operate smoothly and freely. Now raise and lower the cutter slowly with drive shaft turning and again check for interferences or problems.

Adjust so center frame and cutter frame ride with front slightly lower than rear for normal mowing. For variations, see instructions in Operation section.

Reinstall the shield on the cutter.

## Chain Shielding Installation

### DANGER

■ Full chain shielding must be installed when operating in populated areas or other areas where thrown objects could injure people or damage property.

- If this machine is not equipped with full chain shielding, operation must be stopped when anyone comes within 300 feet (92 m).
- This shielding is designed to reduce the risk of thrown objects. The mower deck and protective devices cannot prevent all objects from escaping the blade enclosure in every mowing condition. It is possible for objects to ricochet and escape, traveling as much as 300 feet (92 m).

Chain shielding is bolted to front and rear of cutter with a 1/2 x 1-1/4" hex head cap screws (47), and 1/2" NC flanged lock nuts (49). Chain shielding should be installed as shown on page 38.

## Check Chain Installation

Check chains are used to act as lower limit stops when lowering center frame. They will also prevent the cutter from settling when tractor hydraulic system will not hold the load on the 3-point hitch.

To install, bolt end of chain to diagonal brace of 3-point hitch in holes provided. Position chain on underneath side of plate and install bolt up through chain and through plate. Connect the keyhole hook plates, one on either side of top link.

It may be necessary to replace top link pivot pins with long 3/4 x 6" bolt provided. Adjust chains as required to carry cutter at desired height and angle.

## Counterweight Installation (Optional)

This cutter throws a considerable side load on the 3-point hitch which results in torsion in cross shaft of tractor. If tractor has a fairly small cross shaft, it is advisable to use a counterweight on the left of center frame. This counterweight, as provided, weighs 400 lbs and bolts in place as shown on page 36. Also "suitcase" weights may be used in place of the counterweight box. Use as many as required to attain the 400 lbs counterweight. An empty counterweight box may also be purchased which, if filled with steel punch slugs, will weigh approximately 400 lbs. Use at least 400 lbs; more weight will not be harmful to the machine and may be of some help.



## Tailwheel (Optional)

The tailwheel is ideal for mowing on relatively level ground, orchards, etc. It may not be too useful when mowing ditch banks and rough ground.

To install tailwheel, position angle frame with cross pipe of tailwheel frame between two forward lugs on center frame and install long pin provided. Attach spring cup assembly between the two rear lugs provided on center frame.

Height adjustment is accomplished by positioning spring cup attaching bolt into different holes in tailwheel tubular member. This is a spring-mounted tailwheel and will absorb some shock loading very well.

## Stump Jumper (Optional)

Remove blade pins and blades from crossbar. Remove straps from pan assembly. Discard 3/16" thick spacer which is under keyhole plate.

Install one strap on stump jumper. Slide over crossbar. Install second strap. Align blade pin holes.

Insert blade pin through blade, stump jumper and crossbar. Secure with keyhole plate, lock plate and 1/2" bolt. Use as many blade pin shims as necessary so all freedom is taken from blade pin. Reassemble straps to pan as shown.

## Control Valve Installation (Optional)

The valve provided is a single-spool valve set up for use with open-center hydraulic systems. Refer to page 27 for instructions to convert it for use with closed-center systems. Tractors with closed-center systems include: Ford, John Deere, MF1100-1300, Oliver 1755, 1855, 1955 and MM-1968 and later.

If tractor has an open-center system and pump delivers more than eight gallons per minute continuous flow, larger hoses and fittings in the valve will be required. The valves will handle 25 gallons per minute flow. Consult your tractor manual or dealer if necessary for type and capacity of your tractor hydraulic system.

Position valve on top of bracket as shown and secure with 3/8 x 2-1/2 bolts. Then position fender bracket on right hand fender so controls are convenient to the operator. If it is a narrow-type fender, also use inner brace (29), installing it on tire side of fender.

Drill four holes in fender and, using back-up bars (28) provided, bolt bracket to fender. If it is a wide, flat-top fender, discard inner plate and attach main bracket directly to fender, again drilling four holes and using back-up bars provided.

Using diagonal brace bar, bending and drilling as required, to stiffen fender and valve bracket if it is not rigid enough without it. The narrow extension plate which extends forward on valve bracket is not used with single-spool valve and may be knocked off if it is in the way.

On the inlet (forward) side of valve, install a 1/2 x 3/8" adapter elbow. Into this, screw the 3/8 x 60" one-wire braid hydraulic hose. This hose must be attached to the tractor pressure system wherever it is appropriate. You may have to consult the tractor manual or your dealer to find out where to attach this.

On the return (outlet) side of valve, install a 3/4 x 1/2" reducing bushing followed by a 1/2 x 3/8" 90° adapter elbow. Position both elbows so hoses lie properly.

Install hose barb (37) into elbow fitting and on this, push self-clamping, low-pressure return hose. This will have to return to tractor hydraulic system reservoir at appropriate spot. Consult your tractor dealer or manual. Install other hose barb to tractor system and cut hose to desired length. Install on the barbs.

**NOTE:** Do not slip hose on until you are ready to leave it as hose cannot be removed from barb without cutting it.

Install control lever on valve. Screw 3/8 x 1/4" 90° adapter elbow into top of valve. To it, attach three foot hose which goes to coupler and cylinder.



# NOTES

### Rotary Cutters: S105-3, S106-3, S105Q-3 & S106Q-3

CENTER SECTION ASSEMBLY .....	36
CUTTER HEAD SECTION ASSEMBLY .....	38
TUBULAR SIDE DRIVE ASSEMBLY .....	40
CUTTER HEAD GEARBOX ASSEMBLY .....	41
INPUT GEARBOX ASSEMBLY .....	42
FRONT HALF OF 2-JOINT DRIVE 35R .....	43
SLIP CLUTCH ASSEMBLY .....	44
INTEGRAL U-JOINT SHIELDING .....	45
3-1/2" BORE & 8" STROKE HYDRAULIC CYLINDER .....	46
1-SPOOL, 3-WAY VALVE (OPTIONAL) .....	48
PNEUMATIC TAILWHEEL ASSEMBLY .....	49
PNEUMATIC TIRE ASSEMBLY FOR TAILWHEEL .....	50
HUB ASSEMBLY FOR PNEUMATIC TAILWHEEL .....	50
TAILWHEEL ASSEMBLY .....	51
TAILWHEEL & GAUGE WHEEL ASSEMBLY .....	52
GAUGE WHEEL & TAILWHEEL HUB & AXLE ASSEMBLY .....	52
CROSSBAR PULLER ASSEMBLY .....	53
STUMP JUMPER (OPTIONAL) .....	53

# CENTER SECTION ASSEMBLY

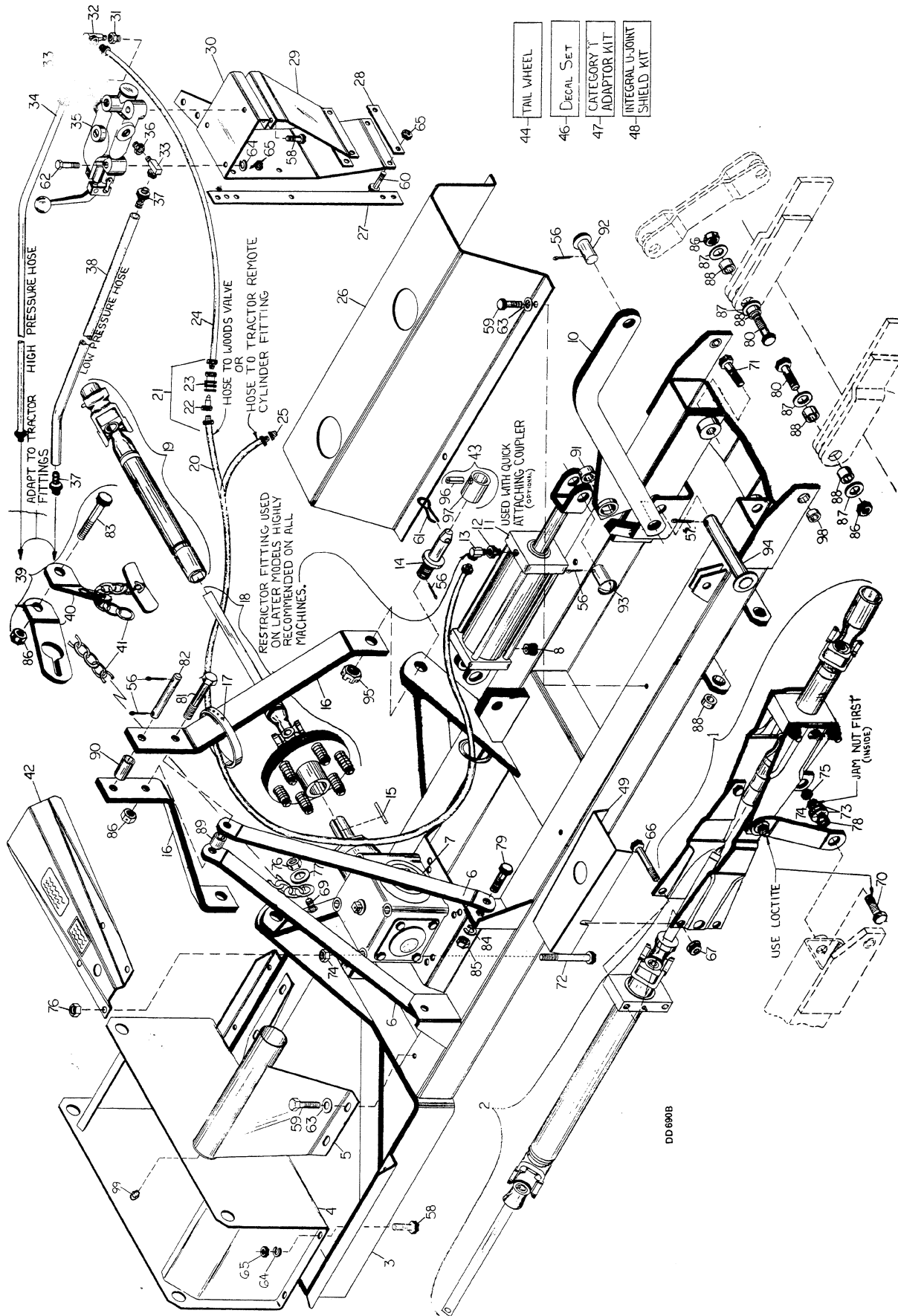

- 44- TAIL WHEEL
- 46- DECAL SET
- 47- CATEGORY 1 ADAPTOR KIT
- 48- INTEGRAL U-JOINT SHIELD KIT

## CENTER SECTION ASSEMBLY

REF	PART	QTY	DESCRIPTION	REF	PART	QTY	DESCRIPTION
1	----	1	Outer side drive assembly (pg 40)	47	7112	1	Cat 2 hitch bushing adapter kit (bushings only for Cat 1 pins) <b>-or-</b>
2	----	1	Inner side drive assembly (pg 40)	47	13010	1	Cat 2 hitch mounting pin kit (mounting pins with 7/8 NF thread) <b>-or-</b>
3	9697	1	540 RPM Center frame (includes gearbox and shields) <b>-or-</b>	47	23101	1	Cat 1 hitch mounting pin kit (3/4 NF thread pins with 1-1/8 sleeves)
3	8427	1	1000 RPM Center frame (includes gearbox and shields)	48	----	1	Integral U-joint shield kit (pg 45)
4	29476	1	Counterweight box (empty) <b>-or-</b>	49	26639	1	Inner drive shield
4	29475	1	Counterweight box (filled w/400 lbs)	<b>HARDWARE</b>			
5	25705	1	Drive shaft shield	REF	PART	QTY	DESCRIPTION
6	25771	2	A-Frame brace bar	55	1266	*	3/16 x 1-1/2 Cotter pin
7	25731	1	540 RPM 1:1 Gearbox (pg 42) <b>-or-</b>	56	1285	*	1/4 x 1-1/2 Cotter pin
7	33315	1	1000 RPM 1.5:1 Gearbox (pg 42)	57	923	*	1/4 x 1-3/4 Cotter pin
8	24767	1	1/2 NPT Check valve assembly	58	839	*	3/8 NC x 1 HHCS GR5
10	25770	1	Lift arm assembly	59	12400		3/8 NC x 1" Sheet metal screw
11	----	1	3-1/2 x 8 Hyd cylinder (pg 46)	60	1017	*	3/8 NC x 1-1/4 HHCS
12	11893	1	1/2 x 1/4 Pipe reducing bushing	61	3282		3/8 x 2-1/4 Lynch pin
13	10290	1	1/4 x 1/4 x 90° Elbow w/1/16 restrictor	62	2290	*	3/8 NC x 2-1/2 HHCS GR5
14	14012	2	Category 2 hitch pin, 1-1/8 drilled	63	565	*	3/8 Standard flat washer
15	7142 *	2	1/4 x 1/4 x 2 Key	64	838	*	3/8 Standard lock washer
16	24789	2	A-Frame half	65	835	*	3/8 NC Hex nut, plated
17	8641	2	Rubber binding strap	66	23479		1/2 x 5 HHCS GR5
18	25769	1	Slip clutch U-joint and sq shaft (pg 44)	67	11900		1/2 NC Flanged hex lock nut
19	9476	1	540 RPM Tubular shaft & QD yoke 11-1/2" (standard) (pg 43) <b>-or-</b>	68	4097		5/8 x 1-1/2 Clevis pin
19	7378	1	540 RPM Tubular shaft & QD yoke 18-1/4" (long) (pg 43) <b>-or-</b>	69	902	*	5/8 NC x 2 HHCS HT
19	33318	1	1000 RPM Tubular shaft & QD yoke 11-1/2" (standard) (pg 43) <b>-or-</b>	70	12274	*	5/8 NC x 2-1/4 HHCS HT
19	33321	1	1000 RPM Tubular shaft & QD yoke 18-1/4" (long) (pg 43)	71	23141		5/8 NC x 3-1/2 HHCS HT
20	12422	1	1/4 x 90° Hydraulic hose and fitting	72	11043		5/8 NC x 7-1/2 HHCS HT
21	8575	1	1/4 Quick disconnect coupler	73	10635		5/8 x 1-3/4 x 14 GA Cup washer
22	8577	1	1/4 Quick disconnect nose assembly	74	1598	*	5/8 NC Hex jam nut
23	8576	1	1/4 Quick disconnect body assembly	75	230	*	5/8 NC Hex nut
24	8107	1	1/4 1-Wire x 36" hydraulic hose	76	6239	*	5/8 NC Hex lock nut
25	11893 *	2	1/2 x 1/4 Pipe reducing bushing	77	3632	*	5/8 Standard SAE flat washer
26	25725	1	Cylinder and drive shield	78	484		5/8 ID x 1" OD x 7/16 HT Sleeve
27	11823	1	Fender valve mounting brace	79	735	*	3/4 NC x 2 HHCS
28	11824	2	Valve bracket reinforcement	80	14334		3/4 NC x 3 HHCS
29	11819	1	Bottom fender valve bracket	81	12558		3/4 NC x 4-1/2 HHCS HT
30	11820	1	Upper fender valve bracket assembly	82	8325		3/4 x 4-27/32 Clevis pin
31	10802 *	1	3/8 x 1/2 Pipe reducing bushing, str	83	2377		3/4 NC x 6 HHCS HT
32	8151	1	3/8M x 1/4F 90° Swivel street elbow	84	2522	*	3/4 Standard lock washer
33	11814	2	1/2M x 3/8 F 90° Swivel elbow	85	1450	*	3/4 NC Hex nut
34	11825	1	3/8 1-Wire x 60" hose and fitting	86	2371	*	3/4 NC Hex lock nut
35	12457	1	1-Spool, 3-way valve (pg 48)	87	1257	*	3/4 Standard flat washer
36	11815 *	2	3/4 x 1/2 Pipe reducing bushing	88	10083		3/4 x 1-1/8 x 5/8 HT Bushing
37	11816	2	1/2 x 3/8 Hydraulic hose coupler	89	25778		3/4 x 1-1/4 x 1-5/16 Sleeve
38	11826	1	1/2 LP x 70" Hydraulic hose	90	7372		25/32 x 1 x 2 Sleeve
39	10521	1	Check chains w/hardware (optional)	91	12270		1 x 1-1/4 x 1 Sleeve HT
40	7906	2	Lower check chain bracket	92	8341		1 x 2-1/2 Clevis pin HT
41	18048	2	3/8 Chain, 32-link & check lug	93	1631		1 x 3-5/8 Clevis pin
42	23489	1	Gearbox shield	94	8359		1-1/8 x 7 HDD Clevis pin
43	24845	1	Quick coupler bushing kit (optional)	95	14153		1-1/8 NF Slotted hex nut
44	12435	1	Tailwheel asy w/lam tire (pg 51) <b>-or-</b>	96	11606		3/8 x 1-1/2 Spirol pin
44	13860	1	Tailwheel w/pneumatic tire (pg 49)	97	24795		1-1/8 x 1-7/16 x 2-3/4 Sleeve
46	12364	1	Complete decal set	98	25723		3/4 x 1-1/8 x 1/2 HT Bushing
				99	195	*	1/8 Straight pipe thread grease fitting
						*	Obtain locally, standard hardware

# CUTTER HEAD SECTION ASSEMBLY

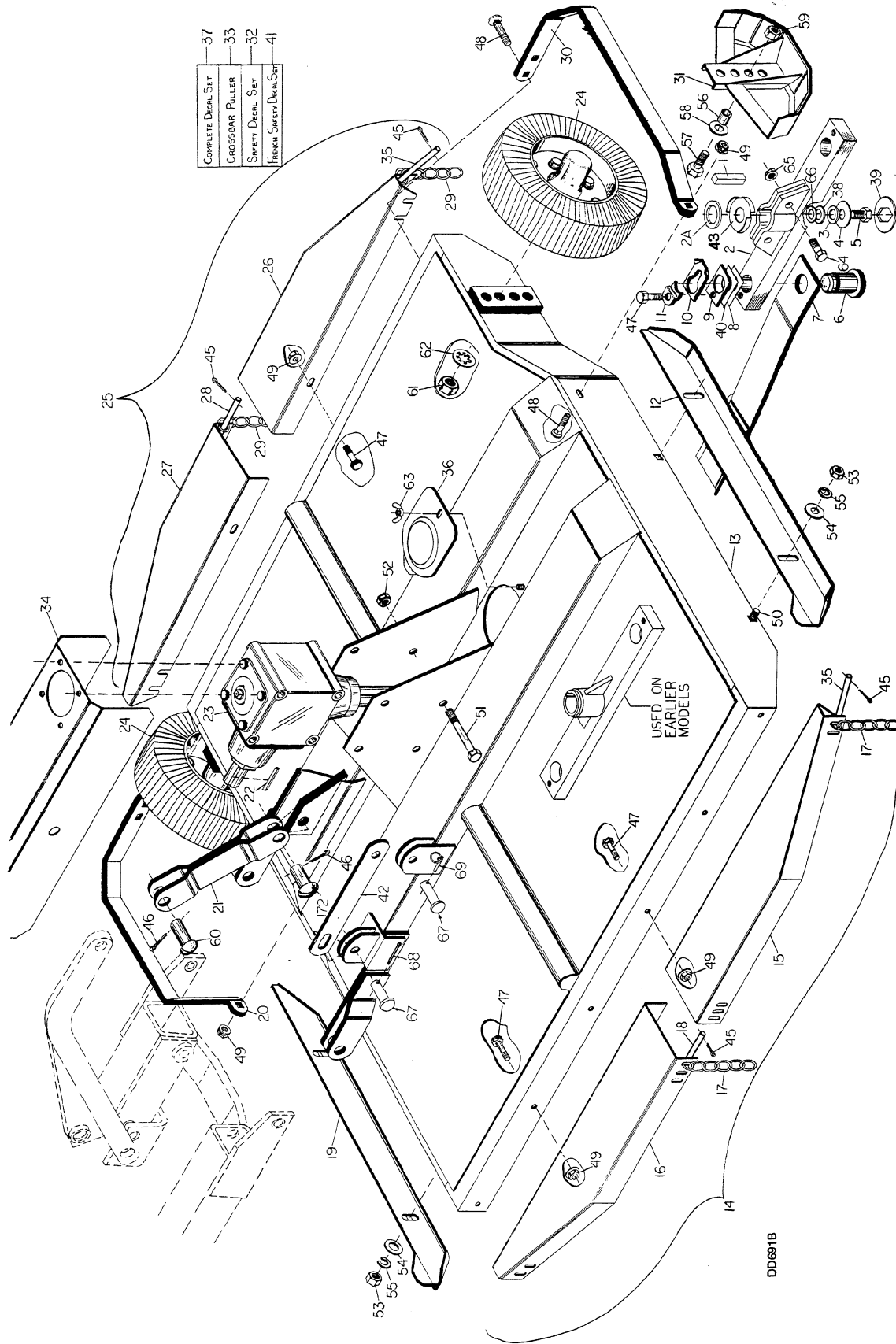

COMPLETE DIAL SET	37
CROSSBAR PULLER	33
SWIVEL DIAL SET	32
FRENCH SWIVEL DIAL SET	41

## CUTTER HEAD SECTION ASSEMBLY

REF	PART	QTY	DESCRIPTION	REF	PART	QTY	DESCRIPTION
1	11041 *	1	3/8 x 3/8 x 2-7/8 Key	27	26981	1	S106 Left front chain plate
2	29269	1	1-5/8 Clamp crossbar (incl. #2A)	28	3783	2	S105 3/8 x 14-3/4 Pin <b>-or-</b>
2A	29272	1	1-5/8 x 2-1/4 x 7 GA Washer	28	26982	2	S106 3/8 x 21-1/2 Pin, 17-chain
3	11204	A/R	13/16 x .010 Shim washer	29	5498	48	S105 5/16 Chain, 6-link <b>-or-</b>
4	7828	1	3/4 x 2-1/2 x 1/4 Washer HT	29	5498	58	S106 5/16 Chain, 6-link
5	4616	1	3/4 NC x 1-1/2 HHCS GR5	30	25772	1	Right wheel guard
6	32602	2	1-1/2 Blade pin - special	31	25800	2	Front corner skid
7	24771KT	2	S105 24" Suction type general purpose blade <b>-or-</b>	32	31895	1	English safety decal set
7	17190KT	2	S105 24" Double-edge flat blade for brush <b>-or-</b>	33	8811	1	Crossbar puller (see pg 53)
7	8820KT	2	S106 30" Suction type general purpose blade <b>-or-</b>	34	26651	1	S105 Side drive shield <b>-or-</b>
7	8830KT	2	S106 30" Double-edge flat blade for brush	34	26652	1	S106 Side drive shield
8	10520	2	18 GA 1-1/2 Blade pin shim	35	3783	4	3/8 x 14-3/4 Pin
9	5523	2	3/16 Spacer	36	3444	1	Access hole cover assembly
10	32603	2	Keyhole plate - special	37	12364	1	Complete English decal set
11	32604	2	Blade pin lock clip - special	38	11036	1	3/4 x 1-1/2 x 18 GA Shim washer
12	1014151	1	Right rear skid assembly (used on S105-3 and early S106-3) <b>-or-</b>	39	5791	1	1-1/8 Washer with hex hole
12	22670	1	Rear skid assembly (used on S105-3 and early S106-3)	40	13946	1	20 GA, 1-1/2 Blade pin shim
13	9695	1	S105-3 Frame (including gearbox, skids & crossbar) <b>-or-</b>	41	51895	1	French safety decal set
13	9696	1	S106-3 Frame (including gearbox, skids & crossbar)	42	19668	1	Lock-up bar 16.00 (on S/N 8499 & below, use #25774 bar & #11697 chain)
14	26976	1	S105 Rear chain shield bundle <b>-or-</b>	43	15831	1	Anti-wrap washer, 3.68 dia
14	26983	1	S106 Rear chain shield bundle	<b>HARDWARE</b>			
15	26974	1	S105 Right rear chain plate <b>-or-</b>	<b>REF</b>	<b>PART</b>	<b>DESCRIPTION</b>	
15	26986	1	S106 Right rear chain plate	45	1256 *	3/16 x 1 Cotter pin	
16	26975	1	S105 Left chain plate <b>-or-</b>	46	1285 *	1/4 x 1-1/2 Cotter pin	
16	26987	1	S106 Left chain plate	47	6100 *	1/2 NC x 1-1/4 HHCS GR5	
17	5498	52	S105 5/16 Chain, 6-link <b>-or-</b>	48	12735	1/2 NC x 1-3/4 Carriage bolt HT	
17	5498	60	S106 5/16 Chain, 6 link	49	11900 *	1/2 NC Flanged hex lock nut	
18	23733	2	S105 3/8 x 17-1/2, 14-chain <b>-or-</b>	50	5607 *	5/8 NC x 1-1/2 Carriage bolt	
18	10150	2	S106 3/8 x 22-1/4 Long pin	51	11043	5/8 NC x 7-1/2 HHCS GR5	
19	1014151	1	Left rear skid assembly (used on S105-3 & early S106-3) <b>-or-</b>	52	6239 *	5/8 NC Hex lock nut	
19	22670	1	Rear skid (used on S106-3 only)	53	230 *	5/8 NC Hex nut	
20	25773	1	Left wheel guard	54	692 *	5/8 Standard flat washer	
21	12412	1	Clevis lift link	55	1286 *	5/8 Heavy lock washer	
22	7142 *	2	1/4 x 1/4 x 2 Key	56	25806	3/4 x 1 x 1-7/8 Sleeve	
23	-----	1	Cutter head gearbox (see pg 41)	57	13759	3/4 NC x 2-1/4 HHCS HT	
24	-----	2	Wheel and hub (see pg 52)	58	1257 *	3/4 Standard flat washer	
25	26967	1	S105 Front chain shielding bundle <b>-or-</b>	59	2371 *	3/4 NC Hex lock nut	
25	26977	1	S106 Front chain shielding bundle	60	8341	1 x 2-1/2 Clevis pin HT	
26	26970	1	S105 Right front chain plate <b>-or-</b>	61	3626	1-14 UNS Hex nut	
26	26980	1	S106 Right front chain plate	62	3689 *	1" Standard lock washer	
27	26971	1	S105 Left front chain plate <b>-or-</b>	63	1287 *	3/8 NC Wing nut	
				64	3699 *	1/2 NC x 2 HHCS GR5	
				65	11900 *	1/2 NC Flanged hex lock nut	
				66	19080	.81 x 1.57 x .07 Washer	
				67	4097	5/8 x 1-1/2 Clevis pin	
				68	1266 *	3/16 x 1-1/2 Cotter pin	
				69	22411	3/16 x 1 Klik pin	

\* Obtain locally, standard hardware

# TUBULAR SIDE DRIVE ASSEMBLY

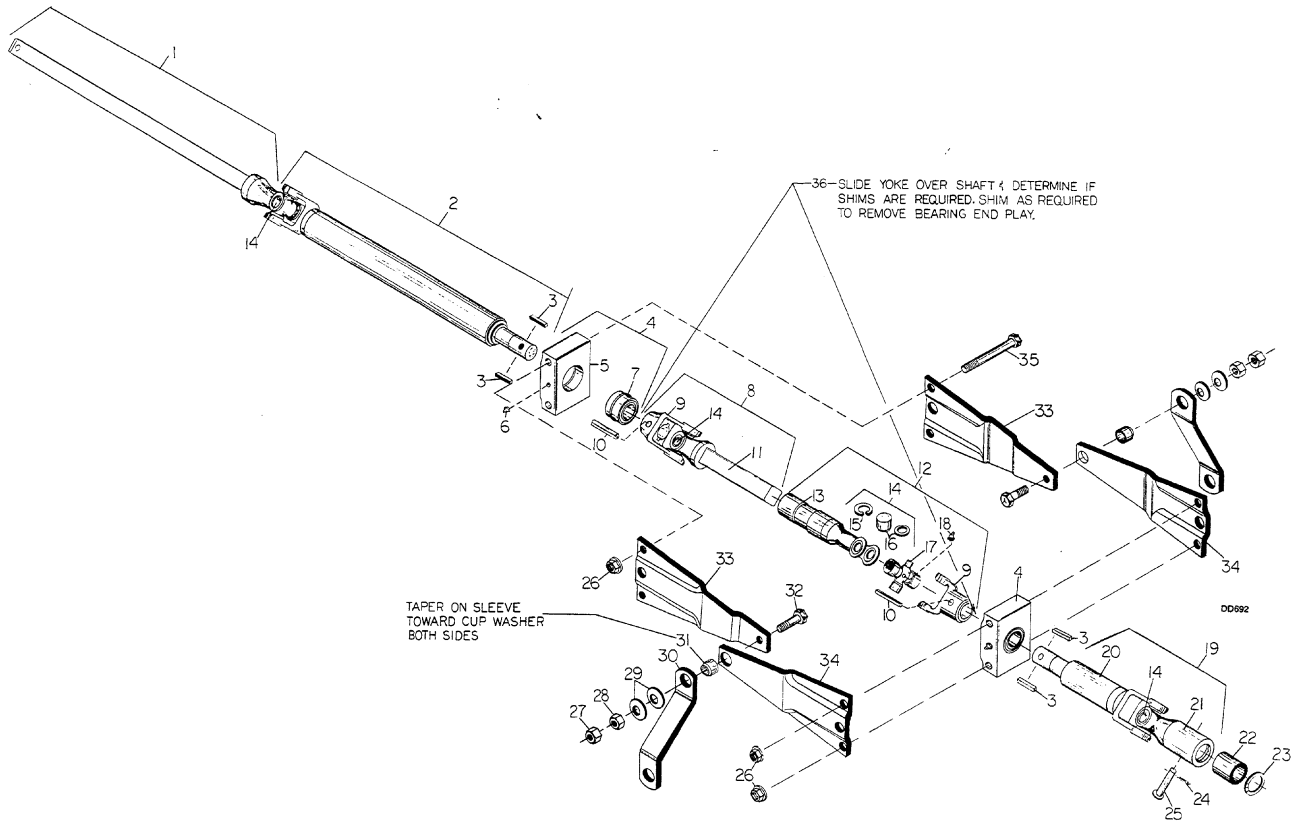

REF	PART	QTY	DESCRIPTION	REF	PART	QTY	DESCRIPTION
1	13964	1	1-1/2 Square shaft 35R yoke 28"	20	23481	1	S105 Special yoke with bearing stub 35R, 10-11/16" long <b>-or-</b>
2	25766	1	Yoke, tube & bearing stub	20	23499	1	S106 Yoke, tube and bearing stub, 35R 16-11/16" long
3	3886 *	4	1/4 x 1/4 x 1-1/4 Key	21	4655	1	Yoke with shear pin sleeve
4	23484	2	Side drive bearing block assembly	22	4659	1	Inner shear sleeve
5	23385	2	Side drive bearing block	23	5278	1	.048 x 2-1/4 Snap ring
6	195 *	2	Straight 1/8 pipe thread grease fitting	24	3597 *	2	1/8 x 1 Cotter pin
7	23450	2	1-1/2 Double bearing repair kit (includes item 36)	25	11895	1	7/16 x 3 Hard shear pin
8	23470	1	Center slip shaft assembly	26	11900	4	1/2 NC Flanged hex lock nut
9	23471	2	1.5 Bore keyed yoke 35R	27	230 *	2	5/8 NC Hex nut
10	7276	2	7/16 x 2-1/2 Spirol pin	28	1598 *	2	5/8 NC Hex jam nut
11	23472	1	Center slip shaft with yoke	29	10635	4	5/8 x 1-3/4 x 14 GA Cup washer
12	23474	1	Inner tube and yoke	30	12312	2	Drive joint support arm
13	23475	1	Inner asy tube & yoke, 1-1/2 sq. sleeve	31	12313	2	5/8 x 1 x 13/16 HT Sleeve
14	110	3	U-joint repair kit 35R	32	12274 *	2	5/8 NC x 2-1/4 HHCS HT
15	N/S	12	Snap ring	33	23469	2	Offset side plate
16	N/S	12	Needle cup and cork washer	34	23477	2	Flat side plate
17	N/S	3	Center cross	35	23479	4	1/2 NC x 5 HHCS GR5
18	N/S	3	Grease fitting	36	30473	-	1-1/2 x 2 x 28 GA Shim (as needed)
19	23480	1	S105 Drive shaft & shear yoke 35R <b>-or-</b>				* Standard hardware, obtain locally
19	23498	1	S106 Drive shaft & shear yoke 35R				N/S Not sold separately

**40 Parts**

29977 (Rev. 1/23/2009)



# CUTTER HEAD GEARBOX ASSEMBLY

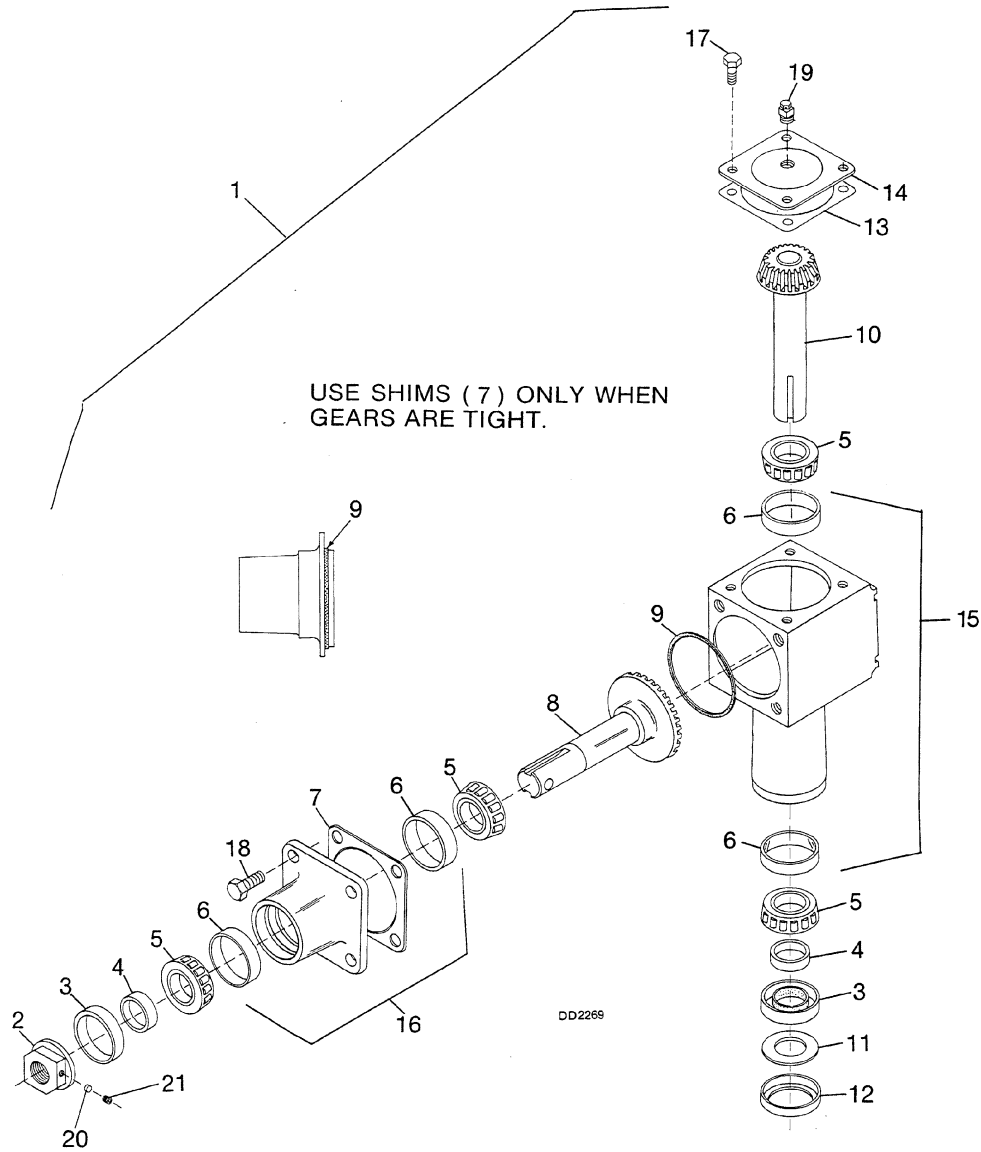

REF	PART	QTY	DESCRIPTION
1	11155	1	S105 1.35:1 Gearbox complete <b>-or-</b>
1	11050	1	S106 1:1 Gearbox complete
2	11007	1	1-5/8 Flanged nut
3	11010	2	Seal for 2-1/8 shaft
4	11054	2	1-5/8 x 2-1/8 x 5/8 Sleeve
5	11114	4	Bearing cone
6	11115	4	Bearing cup
7	11209	1	.010 Gearbox gasket (used only if more backlash is required)
8	11160	1	S105 Horizontal gear and shaft asy (23-tooth) <b>-or-</b>
8	11057	1	S106 Horizontal gear and shaft asy (17-tooth)
9	10055	1	1/8 SQ x 5-1/4 OD O-ring
10	11158	1	S105 Vertical gear & shaft asy (17-tooth) <b>-or-</b>
10	11053	1	S106 Vertical gear & shaft asy (17-tooth)

REF	PART	QTY	DESCRIPTION
11	11056	1	1-5/8 ID x 3 OD x 10 GA Flat washer (used alone) <b>-or-</b>
11	25367	1	1-5/8 ID x 2-3/4 OD x 10 GA Flat washer (used with item 12)
12	25365	1	Gearbox washer retainer
13	11442	1	.062 x 4-1/2 ID x 5 Gasket
14	11005	1	Gearbox cover with plugs
15	11062	1	Housing with cups
16	11063	1	Horizontal housing with cups
17	1686 *	4	3/8 NC x 3/4 HHCS GR5
18	7832 *	4	5/8 NC x 1-1/2 HHCS GR5
19	23057	1	1/2 NPTF Vented pipe plug
20	7127	1	5/16 x 5/32 Dowel plug
21	7269	1	3/8 NC x 3/8 Flat point socket set screw
22	23675	1	1" Breather vent pipe plug (not shown)

\* Standard hardware, obtain locally

# INPUT GEARBOX ASSEMBLY

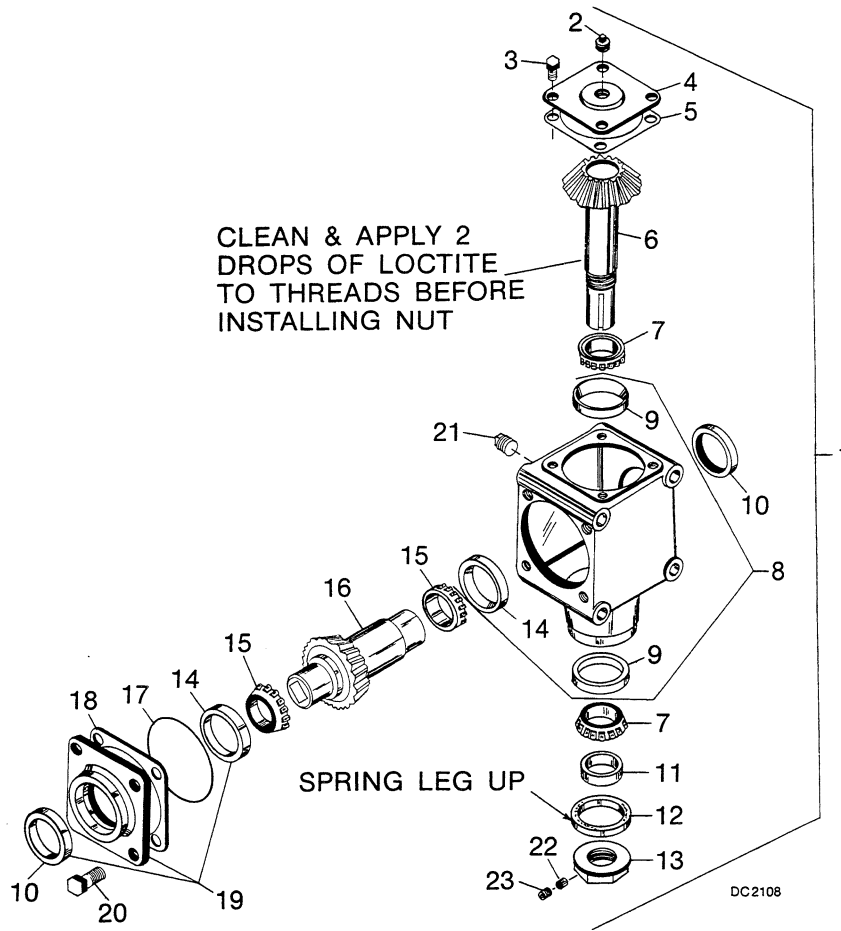

REF	PART	QTY	DESCRIPTION	REF	PART	QTY	DESCRIPTION
1	25731	1	540 RPM Gearbox 1:1 -or-	14	11555	2	Bearing cup, 3.81 OD
1	33315	1	1000 RPM Gearbox 1.5:1	15	11556	2	Bearing cone, 2.25 ID
2	4510 *	1	1/2 Pipe plug	16	17069	1	540 RPM 1:1 Horizontal gear and shaft -or-
3	1686 *	4	3/8 NC x 3/4 HHCS GR5	16	33317	1	1000 RPM Horizontal gear and shaft
4	23051	1	Gearbox cover	17	10055	1	1/8 Square x 5-1/4 OD O-ring
5	11442	1	.062 x 4-1/2 ID x 5 Gasket	18	11209	1	.010 Gearbox gasket -or-
6	18088	1	540 RPM Input gear shaft asy 1.5 -or-	18	17215	1	.005 Gearbox gasket
6	33316	1	1000 RPM Input gear & shaft asy	19	17073	1	Wing bearing cap, cup & seal
7	11114	2	Bearing cone LM501349	20	7832 *	4	5/8 NC x 1-1/2 HHCS GR5
8	25733	1	Gearbox housing with cups	21	23675	-	1" Breather vent pipe plug
9	11115	2	Bearing cup LM501310	22	7127	-	5/16 x 5/32 Dowel plug
10	11553	2	Seal for 2.25 shaft double lip	23	7269	-	3/8 NC x 3/8 Flat point socket set screw
11	11054	1	1-5/8 x 2-1/8 x 5/8 Sleeve			*	Standard hardware, obtain locally
12	11010	1	Seal for 2-1/8 shaft				
13	11007	1	1-5/8 Flanged nut				

**42 Parts**

29977 (Rev. 1/23/2009)

## FRONT HALF OF 2-JOINT DRIVE 35R

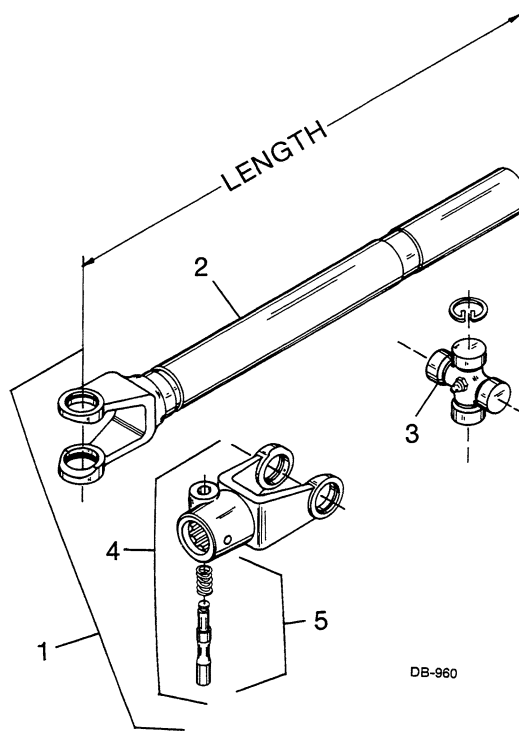

### STANDARD DRIVE

REF	540 RPM	1000 RPM	QTY	DESCRIPTION
1	9476	33318	1	Tubular shaft & joint 35R, 11-1/2"
2	23495	23495	1	Tubular 11-1/2" shaft & yoke 35R
3	110	110	1	Universal joint repair kit 35R
4	115	10938	1	Quick detach U-joint yoke 35R
5	117	117	1	Lock pin & spring

### LONG DRIVE

REF	540 RPM	1000 RPM	QTY	DESCRIPTION
1	7378	33321	1	Tubular shaft & joint 35R, 18-1/4"
2	7379	7379	1	Tubular shaft & yoke, 18-1/4" long, 35R
3	110	110	1	Universal joint repair kit 35R
4	115	10938	1	Quick detach U-joint yoke 35R
5	117	117	1	Lock pin & spring

# SLIP CLUTCH ASSEMBLY

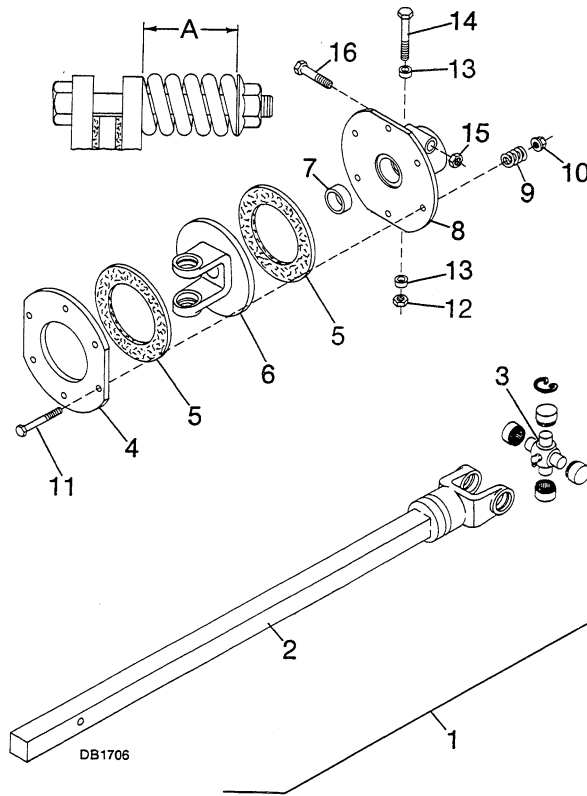

REF	PART	QTY	DESCRIPTION
1	25769	1	6S Clutch 1.5B 35R x 14-1/2" Square shaft
2	23488	1	1-3/16 Square shaft with yoke 35R, 14-1/2"
3	110	1	U-Joint repair kit 35R
4	13931	1	6S Clutch back-up plate
5	19459	2	Friction disc, 4 x 6.15
6	13928	1	6S Clutch yoke and plate 35R
7	11576	1	1-7/16 x 1-5/8 x 9/16 Bronze bushing
8	13933	1	6S Clutch hub, 1-1/2 with bushing
9	29687	6	2 GA x 2-3/16 Compression spring

REF	PART	QTY	DESCRIPTION
10	12914	6	3/8 NC Wide flanged lock nut
11	13927	6	3/8 NC x 3-3/4 HHCS GR5
12	13921 *	1	7/16 NC Hex lock nut
13	-----	-	(Not used on this installation)
14	6048 *	1	7/16 NC x 3-1/2 HHCS GR5
15	6239 *	1	5/8 NC Hex lock nut
16	23141	1	5/8 NC x 3-1/2 HHCS GR5
17	7283	6	Compression spring repair kit (includes items 9-11)

\* Standard hardware, obtain locally

## INTEGRAL U-JOINT SHIELDING (USED ON EARLIER MACHINES)

### STANDARD DRIVE

REF	PART	QTY	DESCRIPTION
1	24441	1	Integral U-joint shield kit, standard
2	7398	2	Integral shield snap ring
3	4677	2	Nylon rectangular groove bearing 35R
4	24443	1	U-Joint outer shield 10"
5	24442	1	U-Joint inner shield 9"

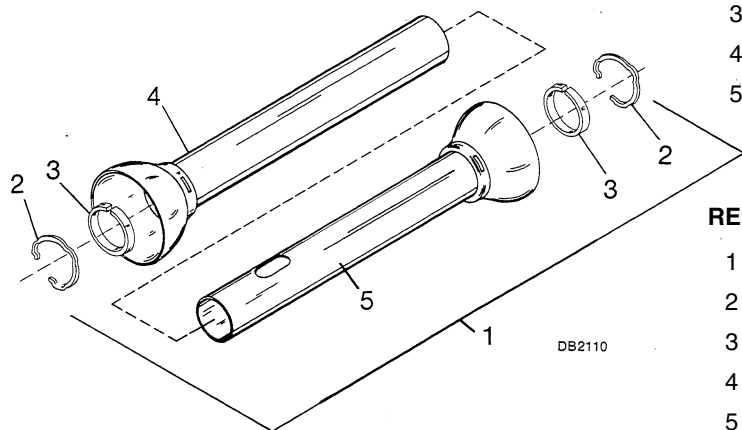

### LONG DRIVE

REF	PART	QTY	DESCRIPTION
1	24444	1	Integral shield kit
2	7398	2	Integral shield snap ring
3	4677	2	Nylon rectangular groove bearing 35R
4	24443	1	U-Joint outer shield 10"
5	4919	1	Inner shield 35R

## U-JOINT SHIELDING (PLASTIC) (USED ON LATER MACHINES)

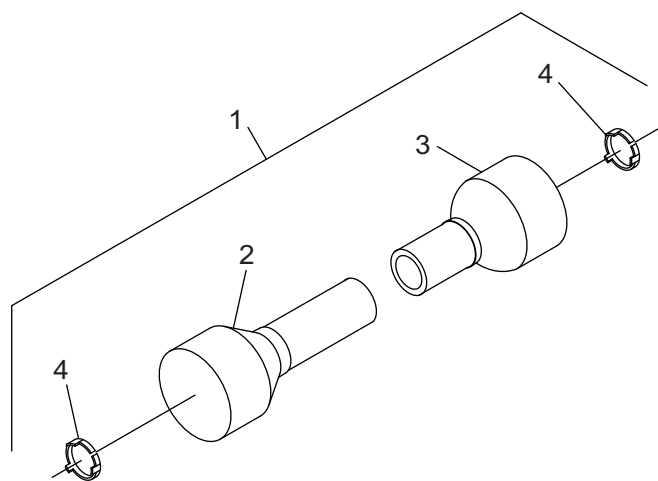

REF	PART	QTY	DESCRIPTION
1	1007870	1	Shield kit, plastic
2	1007871	1	Outer shield, 3.00 x 2.81 x 38.0
3	1007872	1	Inner shield, 2.75 x 2.56 x 43.3
4	15740	2	Shield bearing

**NOTE:** Shield halves must be cut to length. See Assembly Section page 29 for procedures.

## 3-1/2" BORE & 8" STROKE HYDRAULIC CYLINDER

To convert a 10475 cylinder to a 18725 cylinder: Remove the rod hex nuts (15) and tie rods (6). Rotate rod end housing 180° so both ports are in line. Reinstall tie rods and hex nuts. Torque to 55 lbs-ft.

To convert a 18725 cylinder to a 10475 cylinder: Remove tie rod hex nuts (15) and tie rods (6). Rotate rod end housing 180° so ports are on opposite sides. Reinstall tie rods and hex nuts. Torque to 55 lbs-ft.

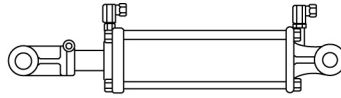

#18725 is a double-acting cylinder. Hoses and fittings are installed in both ports. Vent plug is not required.

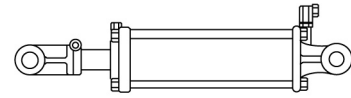

#10475 is a single-acting cylinder. Hoses and fittings are installed in one port and vent plug is installed in another port.

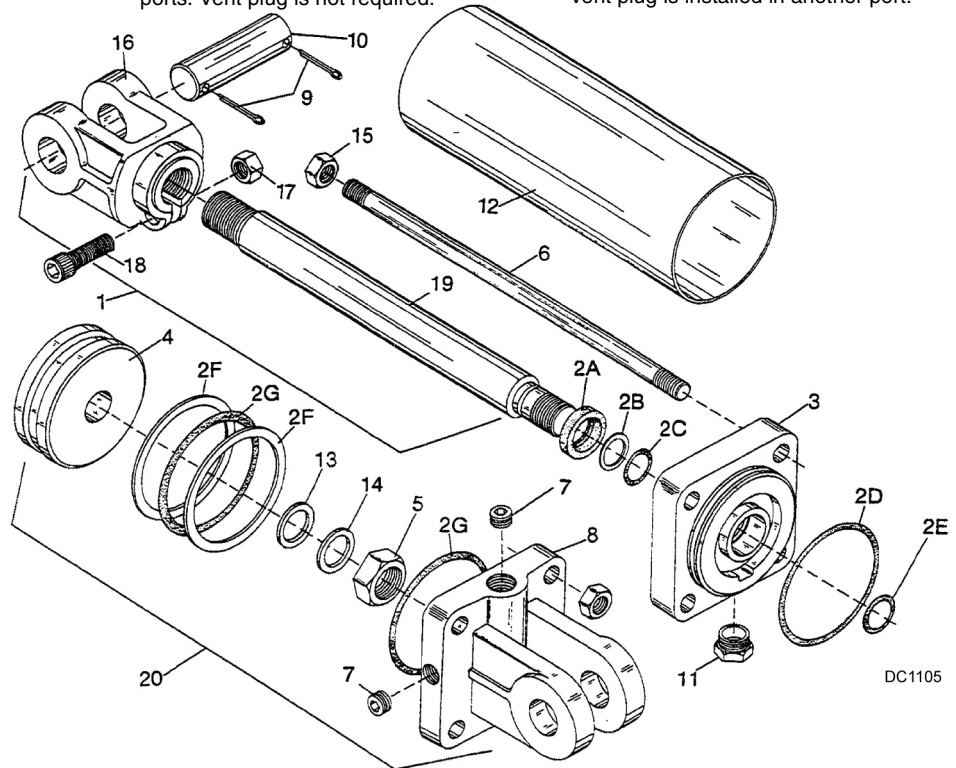

DC1105

Woods purchases hydraulic cylinders from various manufacturers. These cylinders have small dimensional differences. Each cylinder has a brief identification note. Read each note and find the dimensions or identification features for your cylinder. After establishing identification, use the corresponding parts list.

**Lantex or Hydrolite** - Stamped or cast on butt housing (item 8) or rod end housing (item 3).

REF	PART	QTY	DESCRIPTION
2	23540	1	Seal kit (includes 2A - 2G)
2A	----	1	1-1/4 ID Wiper seal
2B	----	1	Rod back-up ring
2C	----	2	1-1/4 ID O-ring
2D	----	2	3/16 x 3-1/2 OD O-ring
2E	----	1	3/32 x 3/4 OD O-ring
2F	----	2	3-1/2 OD Back-up washer
2G	----	1	Piston seal kit
3	26338	1	Rod end housing
4	25497	1	Piston
5	25496	1	1 - 14 UNS Jam nut
6	----	4	Tie rod
7	11893 *	1	1/2 x 1/4 Pipe reducer bushing
8	25494	1	Cylinder butt end
9	923 *	4	1/4 x 1-3/4 Cotter pin

REF	PART	QTY	DESCRIPTION
10	1631	2	1 x 3-5/8 Clevis pin
11	11975	1	1/2 NPT Vent plug -or-
11	23547	1	1/4 NPT Vent plug
12	----	1	Cylinder barrel
15	4391	8	1/2 NF Hex jam nut
16	25661	1	Cylinder rod clevis
17	6698 *	1	3/8 NC Hex lock nut
18	23550 *	1	3/8 NC x 1-1/2 Socket head cap screw
19	26343	1	Cylinder rod
20	10475	1	Hyd cylinder complete (single) -or-
20	18725	1	Hyd cylinder complete (double)
21	4510 *	1	1/2 Pipe plug

**Prince** - Cylinder barrel (12) length is 10-5/8" long. Diameter of cylinder rod (19) is 1-1/8". Cylinder was sold prior to 1971.

REF	PART	QTY	DESCRIPTION
1	----	1	Piston rod asy (incl. 13, 14, 16-19)
2	23540	1	Seal kit (includes 2A - 2G)
2A	----	1	1-1/8 ID Wiper seal
2B	----	1	1-1/8 ID Leather back-up washer
2C	----	2	1-1/8 ID O-ring
2D	----	2	3/16 x 3-1/2 OD O-ring
2E	----	1	3/32 x 3/4 OD O-ring

# 46 Parts

29977 (Rev. 1/23/2009)

REF	PART	QTY	DESCRIPTION
2F	-----	2	3-1/2 OD Back-up washer
2G	-----	1	3/16 x 3-1/2 OD O-ring
3	-----	1	Rod end housing
4	-----	1	Piston
5	3969	1	3/4 NF Hex nut
6	-----	N/A	Tie rod
7	11893 *	1	1/2 x 1/4 Pipe reducer bushing
8	-----	1	Cylinder butt end
9	923 *	4	1/4 x 1-3/4 Cotter pin
10	1631	2	1 x 3-5/8 Clevis pin
11	11975	1	1/2 NPT Vent plug
12	-----	1	Cylinder barrel
13	-----	1	7/8 ID Thread seal
14	-----	1	3/4 ID Flat steel washer
15	1093	8	1/2 NC Heavy hex nut
16	-----	1	Cylinder rod clevis
17	6778 *	1	5/16 NC Hex lock nut
18	6250 *	1	5/16 NC x 1-1/4 Cap screw GR5
19	-----	1	Cylinder rod
20	10475	1	Hyd cylinder complete (single) <b>-or-</b>
20	18725	1	Hyd cylinder complete (double)
21	-----	-	1/2 Pipe plug

**Prince** - Cylinder barrel (12) length is 10-1/6" long. Diameter of cylinder rod (19) is 1-1/8".

REF	PART	QTY	DESCRIPTION
1	-----	1	Piston rod asy (includes 16-19)
2	23540	1	Seal kit (includes 2A - 2G)
2A	-----	1	1-1/8 ID Wiper seal
2B	-----	1	1-1/8 ID Leather back-up washer
2C	-----	2	1-1/8 ID O-ring
2D	-----	2	3/16 x 3-1/2 OD O-ring
2E	-----	1	1/16 x 3/4 ID O-ring
2F	-----	2	3-1/2 OD Back-up washer
2G	-----	1	3/16 x 3-1/2 OD O-ring
3	-----	1	Rod end housing
4	23354	1	Piston
5	3969	1	3/4 NF Hex nut
6	23355	4	Tie rod
7	11893 *	1	1/2 x 1/4 Pipe reducer bushing
8	-----	1	Cylinder butt end
9	923 *	4	1/4 x 1-3/4 Cotter pin
10	1631	2	1 x 3-5/8 Clevis pin
11	11975	1	1/2 NPT Vent plug
12	-----	1	Cylinder barrel
15	1093	8	1/2 NC Heavy hex nut
16	23358	1	Cylinder rod clevis
17	6778 *	1	5/16 NC Hex lock nut
18	6250 *	1	5/16 NC x 1-1/4 Cap screw GR5
19	23360	1	Cylinder rod
20	10475	1	Hyd cylinder complete (single) <b>-or-</b>
20	18725	1	Hyd cylinder complete (double)
21	4510 *	1	1/2 Pipe plug

**Prince** - Cylinder barrel (12) length is 10-1/2" long. Diameter of cylinder rod (19) is 1-1/4".

REF	PART	QTY	DESCRIPTION
2	23540	1	Seal kit (includes 2A - 2G)
2A	-----	1	1-1/4 ID Wiper seal
2C	-----	2	1-1/4 ID O-ring
2D	-----	2	3/16 x 3-1/2 OD O-ring
2F	-----	2	3-1/2 OD Back-up washer
3	23543	1	Rod end housing
4	23544	1	Piston
5	21308	1	1" NF Hex nut
6	-----	4	Tie rod
7	11893 *	1	1/2 x 1/4 Pipe reducer bushing
8	23546	1	Cylinder butt end
9	923 *	4	1/4 x 1-3/4 Cotter pin
10	1631	2	1 x 3-5/8 Clevis pin
11	11975	1	1/2 NPT Vent plug
11	23547	1	1/4 NPT Vent plug
12	-----	1	Cylinder barrel
15	1093	8	1/2 NC Heavy hex nut
15	4391	8	1/2 NF Hex jam nut
16	23549	1	Cylinder rod clevis
17	6698 *	1	3/8 NC Hex lock nut
18	23550 *	1	3/8 NC x 1-1/2 Socket head cap screw
19	23551	1	Cylinder rod
20	10475	1	Hyd cylinder complete (single) <b>-or-</b>
20	18725	1	Hyd cylinder complete (double)
21	-----	-	1/2 Pipe plug

**Lantex or Hydroline** - Stamped or cast on butt housing (8) or rod end housing (3).

REF	PART	QTY	DESCRIPTION
2	25485	1	Seal kit (includes 2A - 2G)
2A	-----	1	1-1/8 ID Wiper seal
2C	-----	1	1-1/8 ID O-ring
2D	-----	2	3/16 x 3-1/2 OD O-ring
2E	-----	1	1-1/16 x 3/4 ID O-ring
2G	-----	1	Block "V" packing seal
3	-----	1	Rod end housing
4	-----	1	Piston
5	N/A	1	7/8 UNF Hex nut
6	23355	4	Tie rod
7	11893 *	1	1/2 x 1/4 Pipe reducer bushing
8	-----	1	Cylinder butt end
9	923 *	4	1/4 x 1-3/4 Cotter pin
10	1631	2	1 x 3-5/8 Clevis pin
11	11975	1	1/2 NPT Vent plug
12	27065	1	Cylinder barrel
15	1093	8	1/2 NC Heavy hex nut
16	25661	1	Cylinder rod clevis
17	6698 *	1	3/8 NC Hex lock nut
18	23550 *	1	3/8 NC x 1-1/2 Socket head cap screw
19	-----	1	Cylinder rod
20	10475	1	Hyd cylinder complete (single) <b>-or-</b>
20	18725	1	Hyd cylinder complete (double)
21	-----	-	1/2 Pipe plug

\* Standard hardware, obtain locally

## 1 SPOOL, 3-WAY VALVE (OPTIONAL)

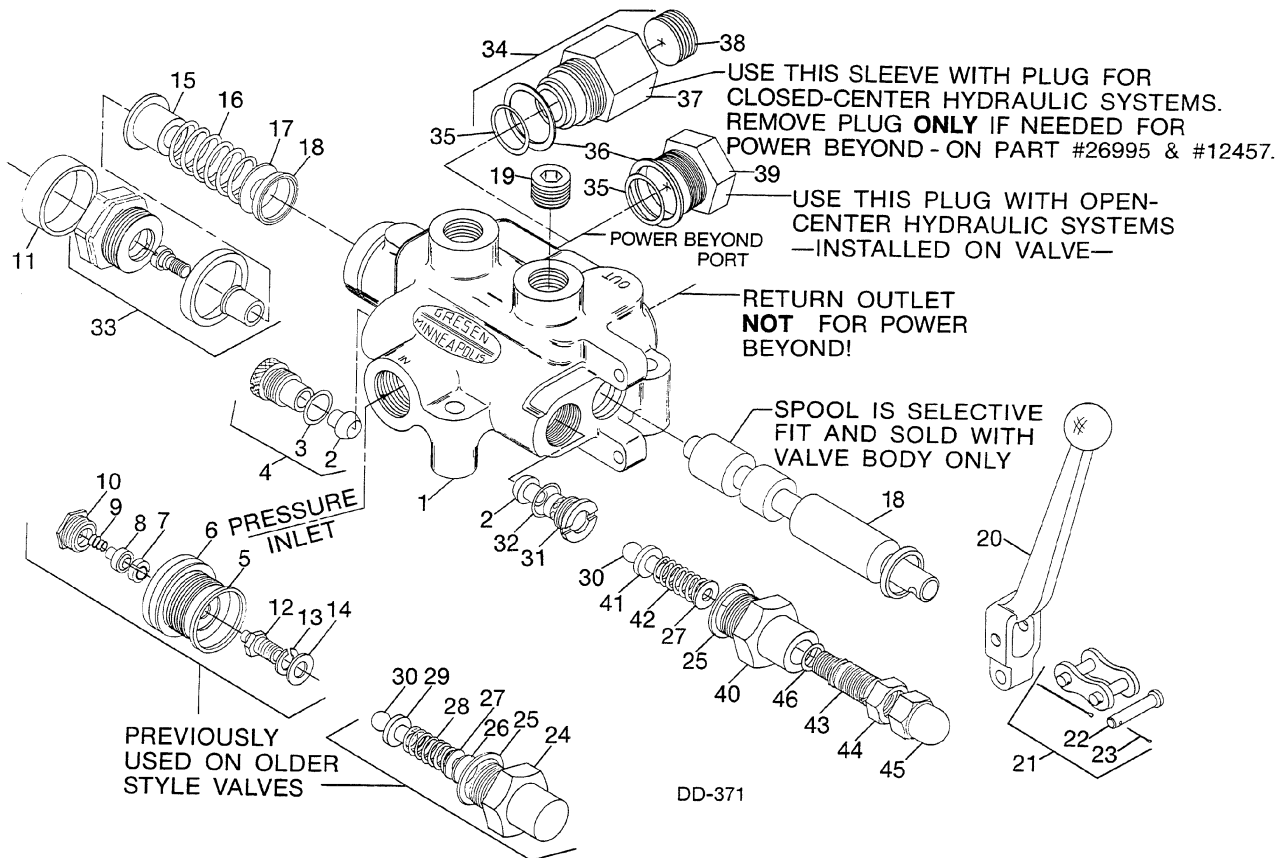

DD-371

REF	PART	QTY	DESCRIPTION	REF	PART	QTY	DESCRIPTION
1	26995	1	1 Spool, 3-way valve w/open center, complete	25	31077	1	Relief copper gasket
2	31097	2	Lift check poppet	26	31081	1	Relief valve adjustment shim
3	31087	1	Check plug gasket	27	31090	1	Relief valve adjustment washer
4	31098	1	Lift check guide plug (includes 2 & 3)	28	31076	1	Relief valve spring
5	-----**	-	O-Ring gasket	29	31096	1	Relief valve poppet follower
6	-----**	-	Detent housing	30	-----	1	Relief valve ball
7	-----**	-	Detent dog	31	31100	1	Relief valve poppet
8	-----**	-	Detent lock follower pin	32	31095	1	Relief valve O-ring
9	-----**	-	Detent lock spring	33	23115	1	Detent kit (replaces 5-10 & 12-14)
10	-----**	-	Detent plug	34	27455	1	Sleeve assembly for power beyond (includes 35-37)
11	11853	1	Rubber cap for spool end	35	31082	1	Nose seal
12	-----**	-	Detent bolt	36	31101	1	Sleeve seal
13	-----**	-	Lock washer	37	-----	-	Sleeve for power beyond (not sold separately, order item 34)
14	-----**	-	Flat washer	38	14434	1	3/4 Pipe plug
15	31072	1	Hat washer	39	31103	1	Plug (includes 35 & 36)
16	31074	1	Spool centering spring	40	31078	1	Body
17	31088	1	Flat washer	41	31086	1	Spring guide
18	11852	2	V Cup spool seal	42	31089	1	Spring
19	4510	1	1/2 Pipe plug	43	31079	1	Adjustment screw
20	11850	1	Handle (includes 21)	44	31083	1	Adjusting jam nut
21	3144	1	#80 Roller chain connector link kit (includes 22 & 23)	45	31084	1	Acorn cap nut
22	11851	1	1/4 x 1-1/4 Clevis pin	46	31080	1	O-Ring adjusting screw
23	31066	1	Cotter pin				** These parts no longer sold separately. Order complete kit, item 33.
24	31094	1	Relief cap				

**48 Parts**

29977 (Rev. 1/23/2009)



## PNEUMATIC TAILWHEEL ASSEMBLY

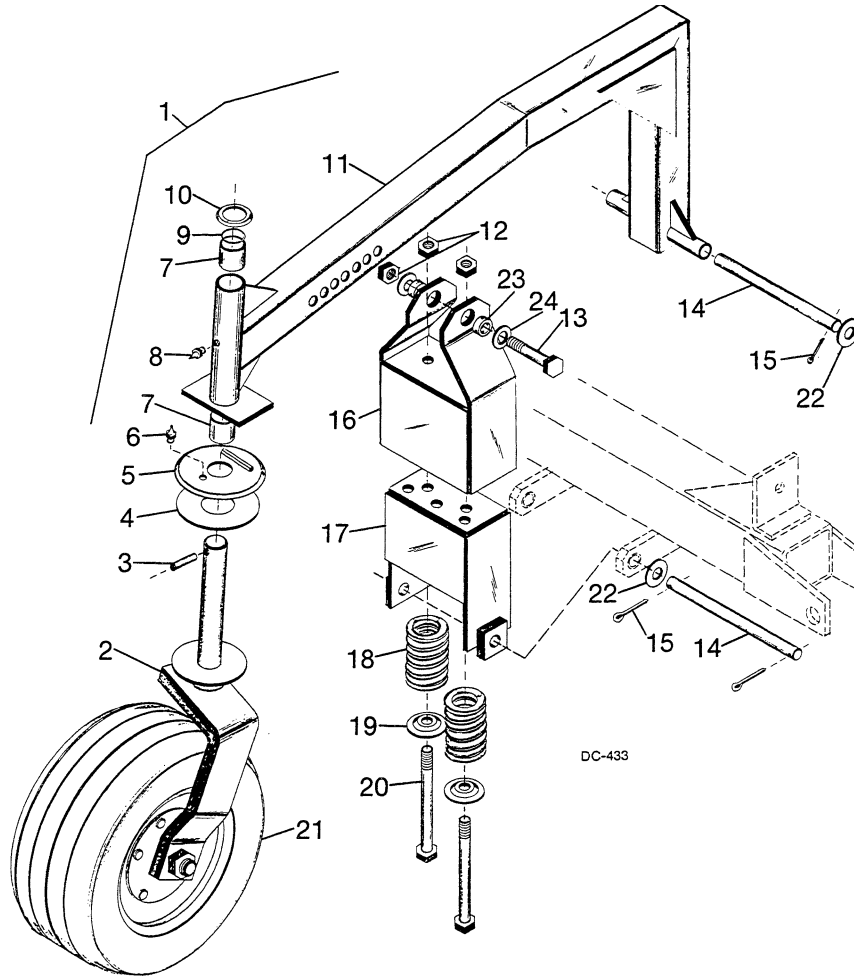

REF	PART	QTY	DESCRIPTION	REF	PART	QTY	DESCRIPTION
1	13860	1	Pneumatic tailwheel asy complete	13	3097	1	5/8 NC x 4-1/2 HHCS GR5
2	14125	1	Tailwheel yoke assembly	14	11872	2	3/4 x 11-1/16 Clevis pin
3	7276	1	7/16 x 2-1/2 Spirol pin	15	1285 *	4	1/4 x 1-1/2 Cotter pin
4	19459	1	Friction disc, 4 x 6.15	16	12443	1	Tailwheel attachment guide cup asy
5	14135	1	Tailwheel dampener top plate asy	17	12449	1	Tailwheel spring housing asy
6	195 *	1	Straight 1/8 pipe thread grease fitting	18	10260	2	1/2 x 6-1/2 Compression spring
7	11011	2	1-1/2 x 1-5/8 x 1-1/2 Bronze bushing	19	12447	2	5/8 x 3 x 7 GA Hat washer
8	1972 *	1	1/4 - 28 Tapered thread grease fitting	20	11043	2	5/8 NC x 7-1/2 HHCS GR5
9	12889	1	3/32 x 1-9/16 OD O-ring	21	----	1	Wheel, tire and hub (see pg 49)
10	12881	1	Tailwheel cap washer	22	1257 *	4	3/4 Flat washer
11	13861	1	Pneumatic tailwheel arm asy	23	484	2	5/8 x 1 x 7/16 HT Sleeve
12	12006	3	5/8 NC Elastic stop nut	24	692 *	2	5/8 Standard flat washer
						*	Standard hardware, obtain locally

## PNEUMATIC TIRE ASSEMBLY FOR TAILWHEEL

TIRE INFLATION: 45 LBS.

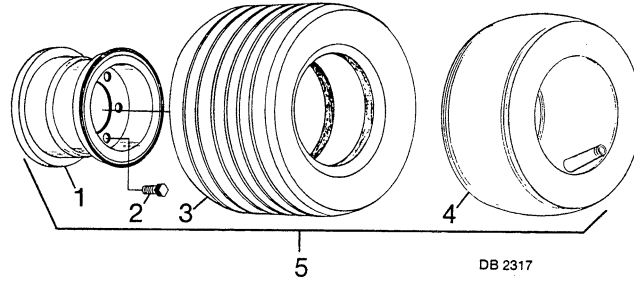

REF	PART	QTY	DESCRIPTION	REF	PART	QTY	DESCRIPTION
1	----	1	Rim for 18 x 9.5 x 8 tire	4	----	1	18 x 9.5 x 8 Inner tube
2	1258	5	1/2 NF x 1-1/8 Wheel bolt	5	14255	1	18 x 9.5 x 8 Rib tire and 5-hole wheel
3	----	1	18 x 9.5 x 8 6-Ply rib tire				

## HUB ASSEMBLY FOR PNEUMATIC TAILWHEEL

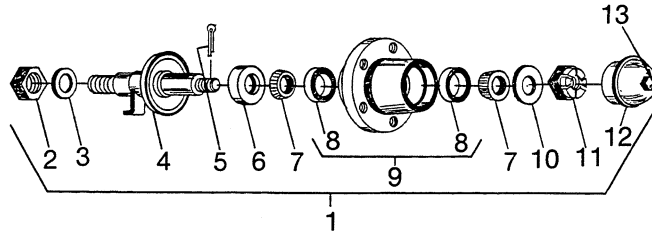

REF	PART	QTY	DESCRIPTION	REF	PART	QTY	DESCRIPTION
1	14130	1	5-Bolt wheel hub with axle	8	2305	2	Bearing cup
2	3626	1	1-14 UNS Hex nut	9	14132	1	5-Bolt wheel hub with cups
3	3689 *	1	1" Standard lock washer	10	1257 *	1	3/4 Standard flat washer
4	14131	1	Tailwheel axle assembly	11	5849	1	3/4 NF Slotted hex nut
5	1266 *	1	3/16 x 1-1/2 Cotter pin	12	14133	1	Hub caps with grease fitting
6	314	1	Seal for 1-1/2 shaft	13	----	1	Straight 1/4 tapered thread grease fitting (for hub caps)
7	2303	2	Bearing cone				* Standard hardware, obtain locally

## TAILWHEEL ASSEMBLY

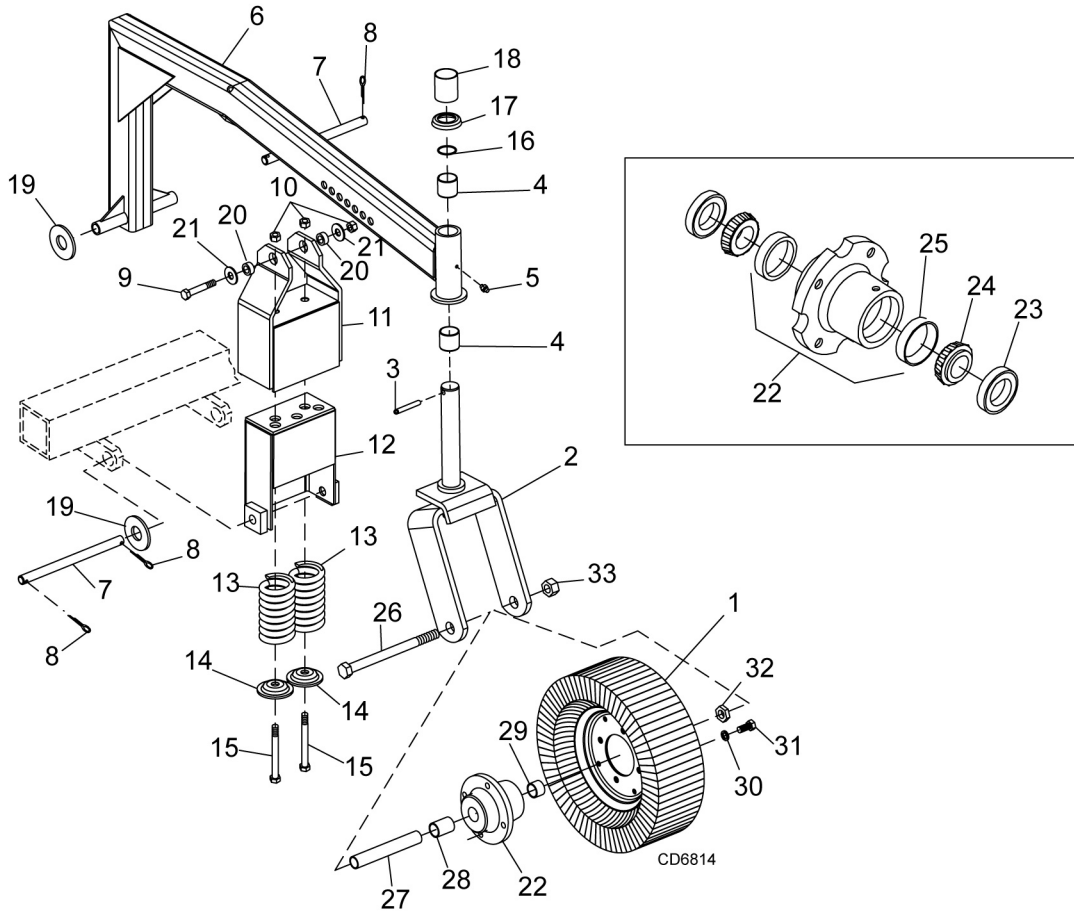

REF	PART	QTY	DESCRIPTION	REF	PART	QTY	DESCRIPTION
1	12577	1	4 x 8 Tire w/rim 5" wide	18	12907	1	1-1/2 Schedule 40 x 2-3/16 pipe (used on heavy yoke only)
2	11131	1	Tailwheel yoke with 1" hole & offset side arm (used with light #2302 hub assembly only)	19	1257 *	4	3/4 Standard flat washer
2	15580	1	Tailwheel clevis	20	484	2	5/8 x 1 x 7/16 HT Sleeve
3	4674	1	3/8 x 2 Spirol pin	21	692 *	2	5/8 Standard flat washer
4	11011	2	1-1/2 x 1-5/8 x 1-1/2 Bronze bushing	22	15277	1	Wheel hub assembly (includes items 21,22,23)
5	1972 *	1	1/4 - 28 Tapered thread grease fitting	23	314	1	Seal for 1-1/2 shaft
6	12436	1	Tailwheel arm asy (incl bushings)	24	310	1	Bearing cone
7	11872	2	3/4 x 11-1/16 Clevis pin	25	309	1	Bearing cup
8	1285 *	4	1/4 x 1-1/2 Cotter pin	26	15087	1	1 NC x 9.0 Cap screw GR5
9	3097	1	5/8 NC x 4-1/2 HHCS GR5	27	15573	1	Sleeve, 1.0 ID x 1.25 OD 5.81
10	12006	3	5/8 Elastic stop nut	28	15575	1	Sleeve, 1.25 ID x 1.50 OD x 1.86
11	12443	1	Tailwheel attachment guide cup asy	29	15574	1	Sleeve, 1.75 ID x 1.50 OD x .903
12	12449	1	Tailwheel spring housing asy	30	855 *	4	1/2 Lock washer
13	10260	2	1/2 x 6-1/2 Compression spring	31	4119	4	1/2 NF x 2 Cap screw GR5
14	12447	2	5/8 x 3 x 7 GA Hat washer	32	1386	1	1" NC Jam nut
15	11043	2	5/8 NC x 7-1/2 HHCS GR5	33	34279	1	1" NC Lock nut
16	12889	1	3/32 x 1-9/16 OD O-ring				
17	12881	1	Tailwheel cap washer				

\* Standard hardware, obtain locally

## TAILWHEEL & GAUGE WHEEL ASSEMBLY

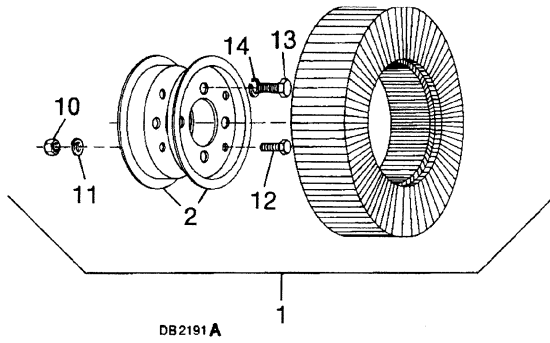

REF	TAILWHEEL PART	GAUGE PART	QTY	DESCRIPTION
1	4676	----	1	4.00 x 8 Rim & laminated tire
2	4679	4679	1	4.00 x 8 Rim half
3	----	25807	1	4.00 x 8 Rim & tire, 14" diameter
10	835 *	835 *	4	3/8 NC Hex nut, plated
11	838 *	838 *	4	3/8 Standard lock washer
12	839 *	839 *	4	3/8 NC x 1 HHCS GR5
13	4119	4119	4	1/2 NF x 1 HHCS GR5
14	855 *	855 *	4	1/2 Extra-heavy lock washer
		*		Standard hardware, obtain locally

## GAUGE WHEEL & TAILWHEEL HUB & AXLE ASSEMBLY

The light-duty or standard hub with 1" axle shaft was used on the tailwheel on early machines and must be used with #12876 yoke with offset side arm and 1" hole. It is also used on current production for cutter head gauge wheels.

The heavy-duty hub with 1-1/4" axle shaft is used on current production and must be used with #12095 yoke with straight side arm and 1-1/4" hole only.

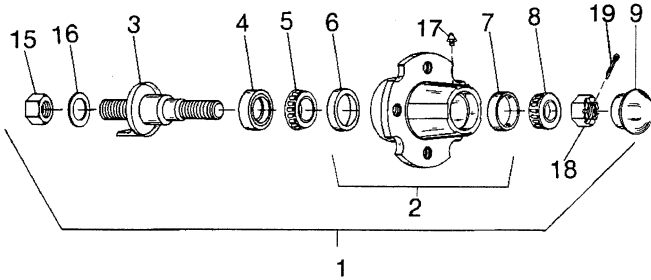

### Standard 1" Shaft

REF	PART	QTY	DESCRIPTION
1	2302	1	Standard wheel hub with axle
2	2307	1	Cast hub with cups
3	2301	1	Axle for standard hub
4	6273	1	Seal, 1.5 x 2.37 x .5
5	2303	1	Bearing cone
6	2305	1	Bearing cup
7	2306	1	Bearing cup
8	2304	1	Bearing cone
9	6248	1	Hub cap - standard
15	3626		1-14 UNS Hex nut
16	3689 *		1" Standard lock washer
17	1972 *		1/4 - 28 Tapered thread grease fitting
18	513		3/4 NF Castle hex nut
19	1256 *		3/16 x 1 Cotter pin
	*		Standard hardware, obtain locally

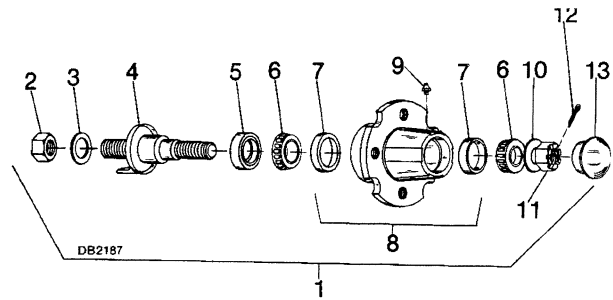

### Heavy-Duty 1-1/4" Shaft

REF	PART	QTY	DESCRIPTION
1	4984	1	Heavy-duty hub with 1-1/4 axle
2	3626	1	1-14 UNS Hex nut
3	3689 *	1	1" Standard lock washer
4	6271	1	Long axle assembly for heavy hub
5	314	1	Seal
6	310	1	Bearing cone, 1.25 ID
7	309	1	Bearing cup, 2.441 OD
8	530	1	Hub (includes bearing cups, item 7)
9	1972 *	1	1/4 - 28 Tapered thread grease fitting
10	1257 *	1	3/4 Standard flat washer
11	5849	1	3/4 NF Slotted hex nut
12	1256 *	1	3/16 x 1 Cotter pin
13	531	1	Hub cap
	*		Standard hardware, obtain locally

## CROSSBAR PULLER ASSEMBLY

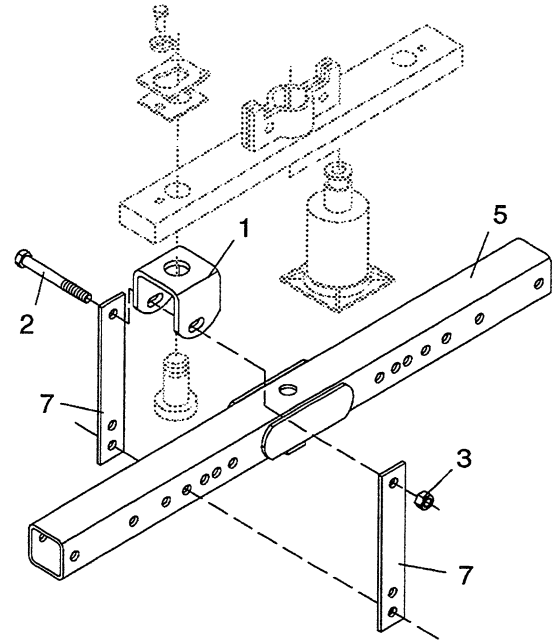
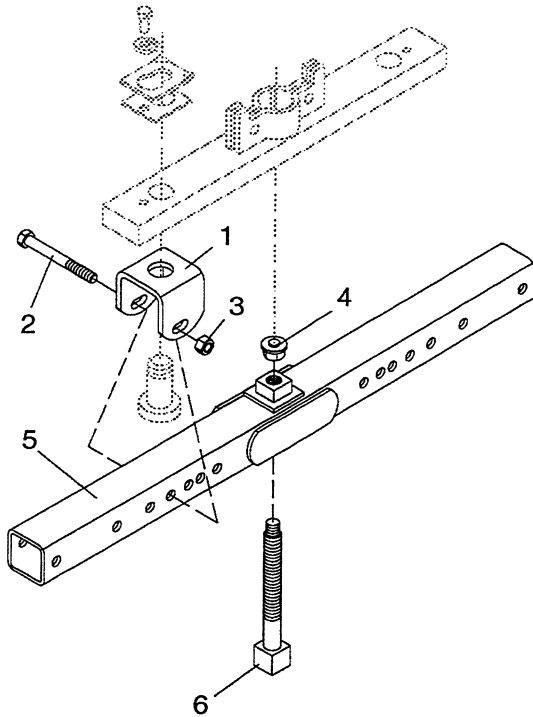

REF	PART	QTY	DESCRIPTION
A	8811	1	Crossbar puller complete
1	19914	2	Crossbar puller clevis
2	3097	4	5/8 NC x 4-1/2 HHCS GR5
3	230 *	4	5/8 NC Hex nut

REF	PART	QTY	DESCRIPTION
4	24879	1	Crossbar puller pad assembly
5	24876	1	Crossbar puller tube assembly
6	24881	1	Crossbar puller screw assembly
7	24885	4	Crossbar puller link
* Standard hardware, obtain locally			

## STUMP JUMPER (OPTIONAL)

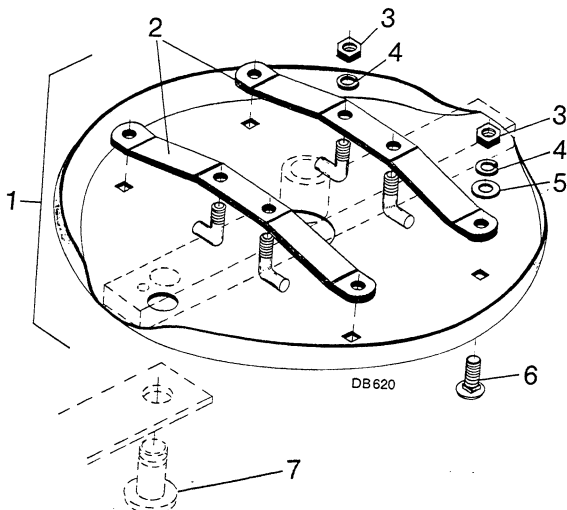

REF	PART	QTY	DESCRIPTION
1	12785	1	Stump jumper complete
2	32641	2	Stump jumper strap
3	230 *	8	5/8 NC Hex nut
4	1286 *	8	5/8 Heavy lock washer
5	692 *	4	5/8 Standard flat washer
6	5607 *	4	5/8 NC x 1-1/2 Carriage bolt
7	32616	2	1-1/2 Blade pin - special, 2.54" (Not included in stump jumper assembly) - used on S106 only

\* Standard hardware, obtain locally

# BOLT TORQUE CHART

Always tighten hardware to these values unless a different torque value or tightening procedure is listed for a specific application.

Fasteners must always be replaced with the same grade as specified in the manual parts list.

Always use the proper tool for tightening hardware: SAE for SAE hardware and Metric for metric hardware.

Make sure fastener threads are clean and you start thread engagement properly.

All torque values are given to specifications used on hardware defined by SAE J1701 MAR 99 & J1701M JUL 96.

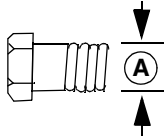

## SAE SERIES TORQUE CHART



SAE Grade 2  
(No Dashes)

SAE Bolt Head Identification



SAE Grade 5  
(3 Radial Dashes)



SAE Grade 8  
(6 Radial Dashes)

Ⓐ Diameter (Inches)	Wrench Size	MARKING ON HEAD					
		SAE 2		SAE 5		SAE 8	
		lbs-ft	N-m	lbs-ft	N-m	lbs-ft	N-m
1/4"	7/16"	6	8	10	13	14	18
5/16"	1/2"	12	17	19	26	27	37
3/8"	9/16"	23	31	35	47	49	67
7/16"	5/8"	36	48	55	75	78	106
1/2"	3/4"	55	75	85	115	120	163
9/16"	13/16"	78	106	121	164	171	232
5/8"	15/16"	110	149	170	230	240	325
3/4"	1-1/8"	192	261	297	403	420	569
7/8"	1-5/16"	306	416	474	642	669	907
1"	1-1/2"	467	634	722	979	1020	1383

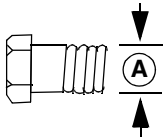

## METRIC SERIES TORQUE CHART



Metric  
Grade 8.8

Metric Bolt Head Identification



Metric  
Grade 10.9

Ⓐ Diameter & Thread Pitch (Millimeters)	Wrench Size	COARSE THREAD				FINE THREAD				Ⓐ Diameter & Thread Pitch (Millimeters)
		MARKING ON HEAD								
		Metric 8.8		Metric 10.9		Metric 8.8		Metric 10.9		
		N-m	lbs-ft	N-m	lbs-ft	N-m	lbs-ft	N-m	lbs-ft	
6 x 1.0	10 mm	8	6	11	8	8	6	11	8	6 x 1.0
8 x 1.25	13 mm	20	15	27	20	21	16	29	22	8 x 1.0
10 x 1.5	16 mm	39	29	54	40	41	30	57	42	10 x 1.25
12 x 1.75	18 mm	68	50	94	70	75	55	103	76	12 x 1.25
14 x 2.0	21 mm	109	80	151	111	118	87	163	120	14 x 1.5
16 x 2.0	24 mm	169	125	234	173	181	133	250	184	16 x 1.5
18 x 2.5	27 mm	234	172	323	239	263	194	363	268	18 x 1.5
20 x 2.5	30 mm	330	244	457	337	367	270	507	374	20 x 1.5
22 x 2.5	34 mm	451	332	623	460	495	365	684	505	22 x 1.5
24 x 3.0	36 mm	571	421	790	583	623	459	861	635	24 x 2.0
30 x 3.0	46 mm	1175	867	1626	1199	1258	928	1740	1283	30 x 2.0

### Typical Washer Installations

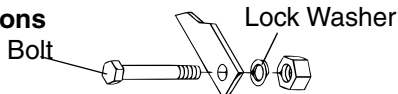

### Flat Washer

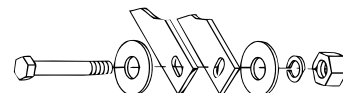
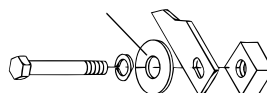

8/9/00

# BOLT SIZE CHART

**NOTE:** Chart shows bolt thread sizes and corresponding head (wrench) sizes for standard SAE and metric bolts.

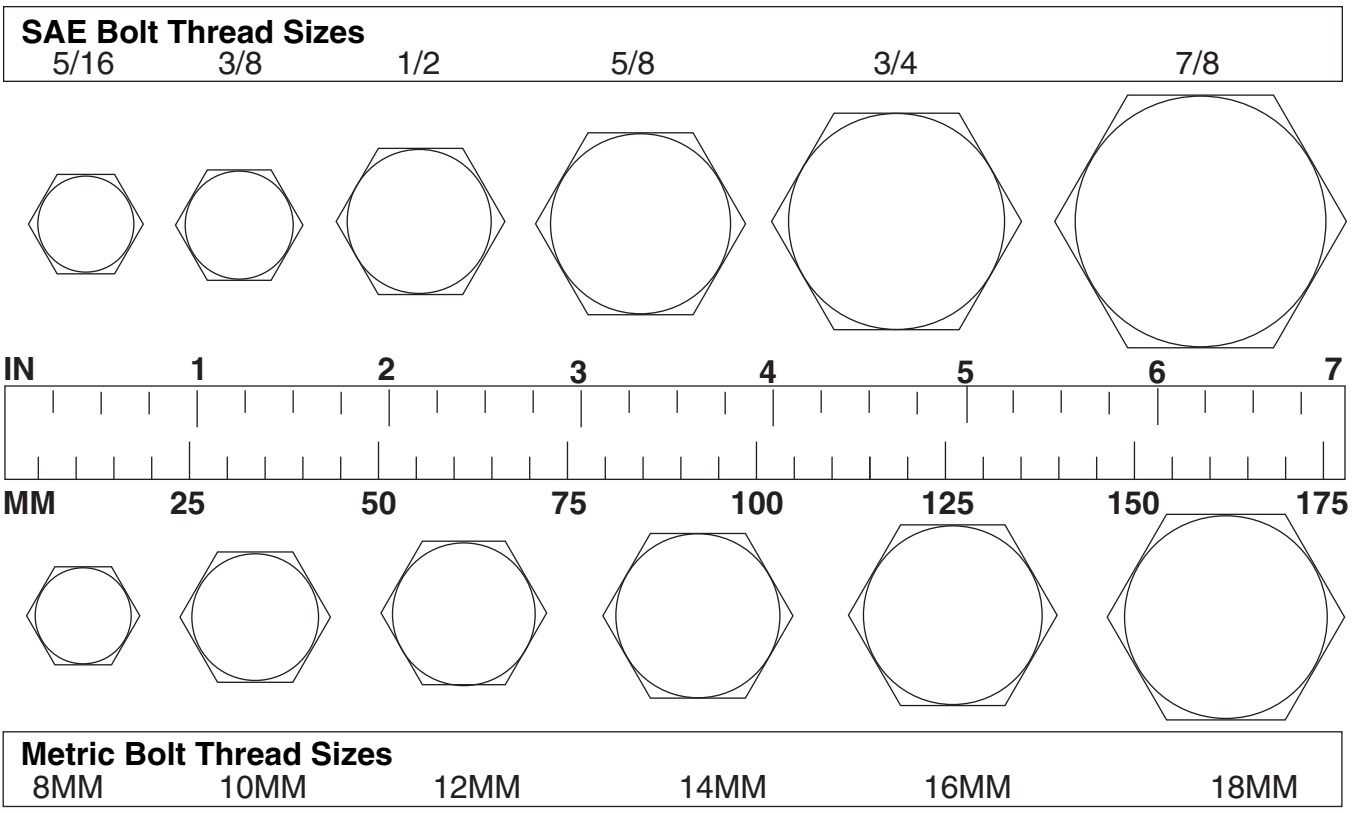

## ABBREVIATIONS

<p>AG ..... Agriculture</p> <p>ASABE..... American Society of Agricultural &amp; Biological Engineers (formerly ASAE)</p> <p>ASAE ..... American Society of Agricultural Engineers</p> <p>ATF ..... Automatic Transmission Fluid</p> <p>BSPP ..... British Standard Pipe Parallel</p> <p>BSPTM ..... British Standard Pipe Tapered Male</p> <p>CV ..... Constant Velocity</p> <p>CCW ..... Counter-Clockwise</p> <p>CW ..... Clockwise</p> <p>F ..... Female</p> <p>FT ..... Full Thread</p> <p>GA ..... Gauge</p> <p>GR (5, etc.) ..... Grade (5, etc.)</p> <p>HHCS ..... Hex Head Cap Screw</p> <p>HT ..... Heat-Treated</p> <p>JIC ..... Joint Industry Council 37° Degree Flare</p> <p>LH ..... Left Hand</p> <p>LT ..... Left</p> <p>m ..... Meter</p> <p>mm ..... Millimeter</p> <p>M ..... Male</p>	<p>MPa ..... Mega Pascal</p> <p>N ..... Newton</p> <p>NC ..... National Coarse</p> <p>NF ..... National Fine</p> <p>NPSM ..... National Pipe Straight Mechanical</p> <p>NPT ..... National Pipe Tapered</p> <p>NPT SWF ..... National Pipe Tapered Swivel Female</p> <p>ORBM ..... O-Ring Boss - Male</p> <p>P ..... Pitch</p> <p>PBY ..... Power-Beyond</p> <p>psi ..... Pounds per Square Inch</p> <p>PTO ..... Power Take Off</p> <p>QD ..... Quick Disconnect</p> <p>RH ..... Right Hand</p> <p>ROPS ..... Roll-Over Protective Structure</p> <p>RPM ..... Revolutions Per Minute</p> <p>RT ..... Right</p> <p>SAE ..... Society of Automotive Engineers</p> <p>UNC ..... Unified Coarse</p> <p>UNF ..... Unified Fine</p> <p>UNS ..... Unified Special</p>
--	---

# INDEX

## ASSEMBLY

Dealer Set-up Instructions 29

## DEALER CHECK LISTS

Delivery (Dealer's Responsibility) 28

Pre-Delivery (Dealer's Responsibility) 28

## DEALER SERVICE

1-Spool, 3-Way Valve 27

Crossbar

Installation 23

Removal 22

Shimming 23

Gearbox Maintenance 21

Assembly - Cutter Head 22

Assembly - Input 22

Horizontal Housing Installation 22

Leakage Repair 21

Output Shaft Installation 22

Removal 22

Seal Installation 21

Spring-Loaded Wheel Yoke Adjustment 27

Universal Joint 25

Assembly 26

Disassembly 25

Repair 25

## GENERAL

Abbreviations 55

Bolt Size Chart 55

Bolt Torque Chart 54

Introduction 2

Obtaining Replacement Manuals 2

Product Registration 2

Warranty

Product 57

Replacement Parts, Back Cover

## OPERATION

Attach Cutter to Tractor 14

Cutting Height & Attitude Adjustment 14

General Mowing 15

Blade Selection 15

Brush and Ditch Bank Mowing 16

Cutter Head Lift 15

Tractor and Cutter Operation 15

General Tractor Operation 13

Pre-Operation Check List 14

Side Skid Adjustment 14

Storage 16

Tailwheel Adjustment 14

Tractor Stability 13

Transport 16

## OWNER SERVICE

Blade Servicing 18

Installation 18

Removal 18

Sharpening 18

Chain Shielding Repair 19

Cleaning 19

Lubrication 17

Slip Clutch Adjustment 18

## PARTS

Parts Index 35

## SAFETY

Check Lists

Delivery (Dealer's Responsibility) 28

Pre-Delivery (Dealer's Responsibility) 28

Pre-Operation Check List 14

Free Mower Safety Video Order Form 5, 6

Safety & Instructional Decals 10

Safety Rules 7

Safety Symbols Explained 2

## TROUBLE SHOOTING 20





# WARRANTY

(All Models Except Mow'n Machine™ Zero-Turn Mowers and Woods Boundary™ Utility Vehicles)

Please Enter Information Below and Save for Future Reference.

Date Purchased: \_\_\_\_\_ From (Dealer): \_\_\_\_\_

Model Number: \_\_\_\_\_ Serial Number: \_\_\_\_\_

Woods Equipment Company ("WOODS") warrants this product to be free from defect in material and workmanship. Except as otherwise set forth below, the duration of this Warranty shall be for TWELVE (12) MONTHS COMMENCING ON THE DATE OF DELIVERY OF THE PRODUCT TO THE ORIGINAL PURCHASER.

Woods backhoe models BH70-X, BH80-X, and BH90-X are warranted for two (2) years from the date of delivery to the original purchaser.

The warranty periods for specific parts or conditions are listed below:

Part or Condition Warranted	Model Number	Duration (from date of delivery to the original purchaser)
Gearbox components	BW1260, BW1620, BW1800, BW2400	8 years
	BW240HD	7 years
	BB48X, BB60X, BB72X, BB84X, BB600X, BB720X, BB840X, BB6000X, BB7200X, BB8400X, DS1260, DSO1260, DS1440, TS1680, BW126-3, BW180-3, BW240	6 years
	PHD25, PHD35, PHD65, PHD95, 2162, 3240, DS96, DS120, RCC42, RM550-2, RM660-2, RM990-3, PRD6000, PRD7200, PRD8400, 7144RD-2, 9180RD-2, 9204RD-2, S15CD, S20CD, S22CD, S25CD, S27CD	5 years
	RDC54, RD60, RD72, TBW150C	3 years (1 year if used in rental or commercial applications)
Blade spindles	RM550-2, RM660-2, RM990-3, PRD6000, PRD7200, PRD8400, 7144RD-2, 9180RD-2, 9204RD-2	3 years
Rust-through	BB600, BB720, BB840, BB6000, BB7200, BB8400, BW126-3, BW180-3, BW1260, BW1800, BW240, BW240HD, 2162, 3240, DS1260, DSO1260, DS1440, TS1680	10 years

Under no circumstances will this Warranty apply in the event that the product, in the good faith opinion of WOODS, has been subjected to improper operation, improper maintenance, misuse, or an accident. This Warranty does not apply in the event that the product has been materially modified or repaired by someone other than WOODS, a WOODS authorized dealer or distributor, and/or a WOODS authorized service center. This Warranty does not cover normal wear or tear, or normal maintenance items. This Warranty also does not cover repairs made with parts other than those obtainable through WOODS.

This Warranty is extended solely to the original purchaser of the product. Should the original purchaser sell or otherwise transfer this product to a third party, this Warranty does not transfer to the third party purchaser in any way. There are no third party beneficiaries of this Warranty.

WOODS makes no warranty, express or implied, with respect to engines, batteries, tires or other parts or accessories not manufactured by WOODS. Warranties for these items, if any, are provided separately by their respective manufacturers.

WOODS' obligation under this Warranty is limited to, at WOODS' option, the repair or replacement, free of charge, of the product if WOODS, in its sole discretion, deems it to be defective or in noncompliance with this Warranty. **The product must be returned to WOODS with proof of purchase within thirty (30) days after such defect or noncompliance is discovered or should have been discovered, routed through the dealer and distributor from whom the purchase was made, transportation charges prepaid.** WOODS shall complete such repair or replacement within a reasonable time after WOODS receives the product. **THERE ARE NO OTHER REMEDIES UNDER THIS WARRANTY. THE REMEDY OF REPAIR OR REPLACEMENT IS THE SOLE AND EXCLUSIVE REMEDY UNDER THIS WARRANTY.**

THERE ARE NO WARRANTIES WHICH EXTEND BEYOND THE DESCRIPTION ON THE FACE OF THIS WARRANTY. WOODS MAKES NO OTHER WARRANTY, EXPRESS OR IMPLIED, AND WOODS SPECIFICALLY DISCLAIMS ANY IMPLIED WARRANTY OF MERCHANTABILITY AND/OR ANY IMPLIED WARRANTY OF FITNESS FOR A PARTICULAR PURPOSE.

**WOODS shall not be liable for any incidental or consequential losses, damages or expenses, arising directly or indirectly from the product, whether such claim is based upon breach of contract, breach of warranty, negligence, strict liability in tort or any other legal theory.** Without limiting the generality of the foregoing, Woods specifically disclaims any damages relating to (i) lost profits, business, revenues or goodwill; (ii) loss of crops; (iii) loss because of delay in harvesting; (iv) any expense or loss incurred for labor, supplies, substitute machinery or rental; or (v) any other type of damage to property or economic loss.

This Warranty is subject to any existing conditions of supply which may directly affect WOODS' ability to obtain materials or manufacture replacement parts.

No agent, representative, dealer, distributor, serviceperson, salesperson, or employee of any company, including without limitation, WOODS, its authorized dealers, distributors, and service centers, is authorized to alter, modify, or enlarge this Warranty.

Answers to any questions regarding warranty service and locations may be obtained by contacting:

**Woods Equipment Company**  
 2606 South Illinois Route 2  
 Post Office Box 1000  
 Oregon, Illinois 61061 USA  
 800-319-6637 tel  
 800-399-6637 fax  
 www.WoodsEquipment.com



**ALITEC™**  
**BMP®**  
**CENTRAL FABRICATORS®**  
**GANNON®**  
**GILL®**  
**WAIN-ROY®**  
**WOODS®**



# WARRANTY

(Replacement Parts For All Models Except Mow'n Machine™  
Zero-Turn Mowers and Woods Boundary™ Utility Vehicles)

Woods Equipment Company ("WOODS") warrants this product to be free from defect in material and workmanship for a period of ninety (90) days from the date of delivery of the product to the original purchaser with the exception of V-belts, which will be free of defect in material and workmanship for a period of 12 months.

Under no circumstances will this Warranty apply in the event that the product, in the good faith opinion of WOODS, has been subjected to improper operation, improper maintenance, misuse, or an accident. This Warranty does not cover normal wear or tear, or normal maintenance items.

This Warranty is extended solely to the original purchaser of the product. Should the original purchaser sell or otherwise transfer this product to a third party, this Warranty does not transfer to the third party purchaser in any way. There are no third party beneficiaries of this Warranty.

WOODS' obligation under this Warranty is limited to, at WOODS' option, the repair or replacement, free of charge, of the product if WOODS, in its sole discretion, deems it to be defective or in noncompliance with this Warranty. **The product must be returned to WOODS with proof of purchase within thirty (30) days after such defect or noncompliance is discovered or should have been discovered, routed through the dealer and distributor from whom the purchase was made, transportation charges prepaid.** WOODS shall complete such repair or replacement within a reasonable time after WOODS receives the product. THERE ARE NO OTHER REMEDIES UNDER THIS WARRANTY. THE REMEDY OF REPAIR OR REPLACEMENT IS THE SOLE AND EXCLUSIVE REMEDY UNDER THIS WARRANTY.

THERE ARE NO WARRANTIES WHICH EXTEND BEYOND THE DESCRIPTION ON THE FACE OF THIS WARRANTY. WOODS MAKES NO OTHER WARRANTY, EXPRESS OR IMPLIED, AND WOODS SPECIFICALLY DISCLAIMS ANY IMPLIED WARRANTY OF MERCHANTABILITY AND/OR ANY IMPLIED WARRANTY OF FITNESS FOR A PARTICULAR PURPOSE.

**WOODS shall not be liable for any incidental or consequential losses, damages or expenses, arising directly or indirectly from the product, whether such claim is based upon breach of contract, breach of warranty, negligence, strict liability in tort or any other legal theory.** Without limiting the generality of the foregoing, Woods specifically disclaims any damages relating to (i) lost profits, business, revenues or goodwill; (ii) loss of crops; (iii) loss because of delay in harvesting; (iv) any expense or loss incurred for labor, supplies, substitute machinery or rental; or (v) any other type of damage to property or economic loss.

This Warranty is subject to any existing conditions of supply which may directly affect WOODS' ability to obtain materials or manufacture replacement parts.

No agent, representative, dealer, distributor, service person, salesperson, or employee of any company, including without limitation, WOODS, its authorized dealers, distributors, and service centers, is authorized to alter, modify, or enlarge this Warranty.

Answers to any questions regarding warranty service and locations may be obtained by contacting:

**Woods Equipment Company**

2606 South Illinois Route 2  
Post Office Box 1000  
Oregon, Illinois 61061

815-732-2141 tel  
815-732-7580 fax  
www.WoodsEquipment.com



**ALITEC™**  
**BMP®**  
**CENTRAL FABRICATORS®**  
**GANNON®**  
**GILL®**  
**WAIN-ROY®**  
**WOODS®**