

ROVIO

Pivot™

THE ULTIMATE TABLET STAND

USER MANUAL

ITEM NO.: 0850

INTRODUCTION

Thank you for purchasing Rovio Pivot™ from WowWee™!

Rovio Pivot™ is a multi-functional tablet stand that serves a variety of consumer needs including remote video conferencing, as well as a built-in entertainment system.

PACKAGE CONTENTS

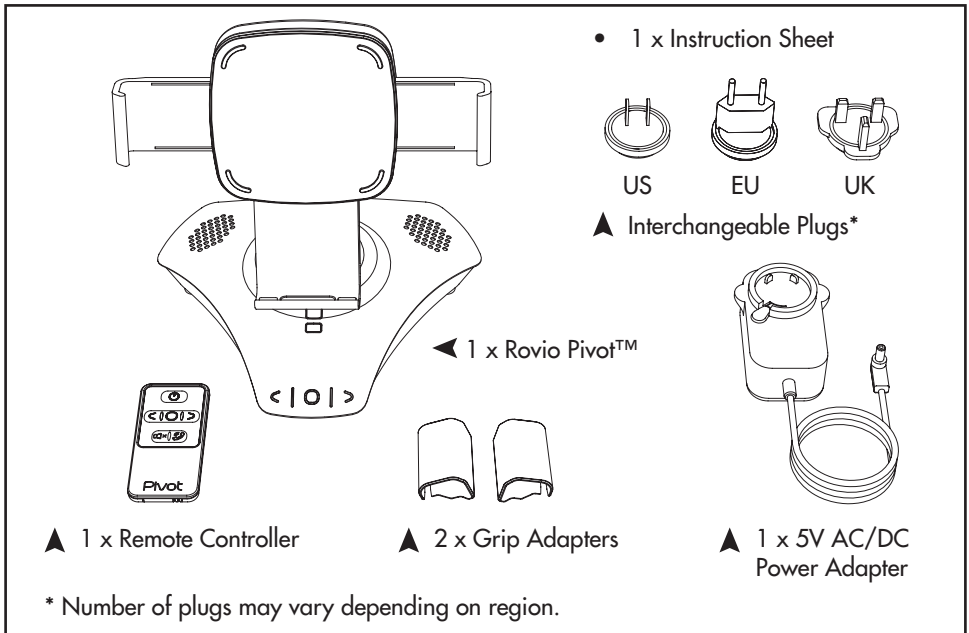

Please note the following when operating Rovio Pivot™:

- Do not immerse Rovio Pivot™ or any parts in water or any other form of liquid.
- Do not drop, throw, or kick Rovio Pivot™ as this might damage mechanical functions.
- Do not manually turn Rovio Pivot™ in either direction while it is moving.

BATTERY INFORMATION

Installing or changing batteries in the Remote Controller:

1. To change the batteries, turn to the back of the Remote Controller. The Remote Controller requires 1 x "CR2032 3V" size battery (included).
2. Remove the Battery Holder by pressing the latch located on the left, towards the right and pull downwards as shown in diagram.
3. Insert the battery according to the diagram. Ensure that the positive and negative polarities match the illustration shown.
4. Push the Battery Holder all the way back into the Remote Controller. A soft click indicates that the Battery Holder has been securely attached.

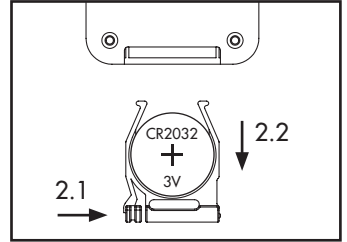

NOTE: Out of the box, you will notice a clear plastic strip extending from within the battery compartment of the Remote Controller. Activate the Remote Controller by removing and discarding this insulation tab by pulling in the direction shown. The Remote Controller functions without this tab.

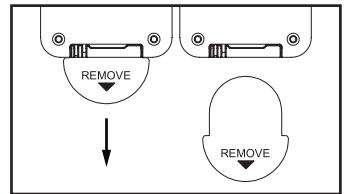

Installing or changing the Interchangeable Plugs:

1. To change the Interchangeable Plugs, first press and hold on the Lock Release Button.
2. Then twist plug as shown in diagram to release.
3. Position desired plug in position and twist in the opposite direction to lock. A soft click indicates that the plug has been securely attached.

TIP: Positioning steel pins to the top of the adapter will facilitate assembly.

NOTE: Rovio Pivot™ must only be used with the transformer included.

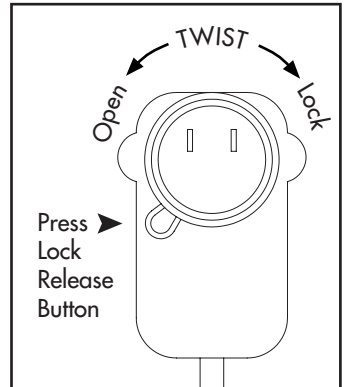

IMPORTANT BATTERY INFORMATION:

- Use only fresh batteries of the required size and recommended type.
- Please respect the correct polarity, (+) and (-).
- Do not try to recharge non-rechargeable batteries.
- Do not throw batteries into fire.
- The supply terminals are not to be short-circuited.
- Remove exhausted batteries from the unit.
- Batteries should be replaced by adults.

QUICK OVERVIEW

ROVIO PIVOT™

MOTORIZED BASE

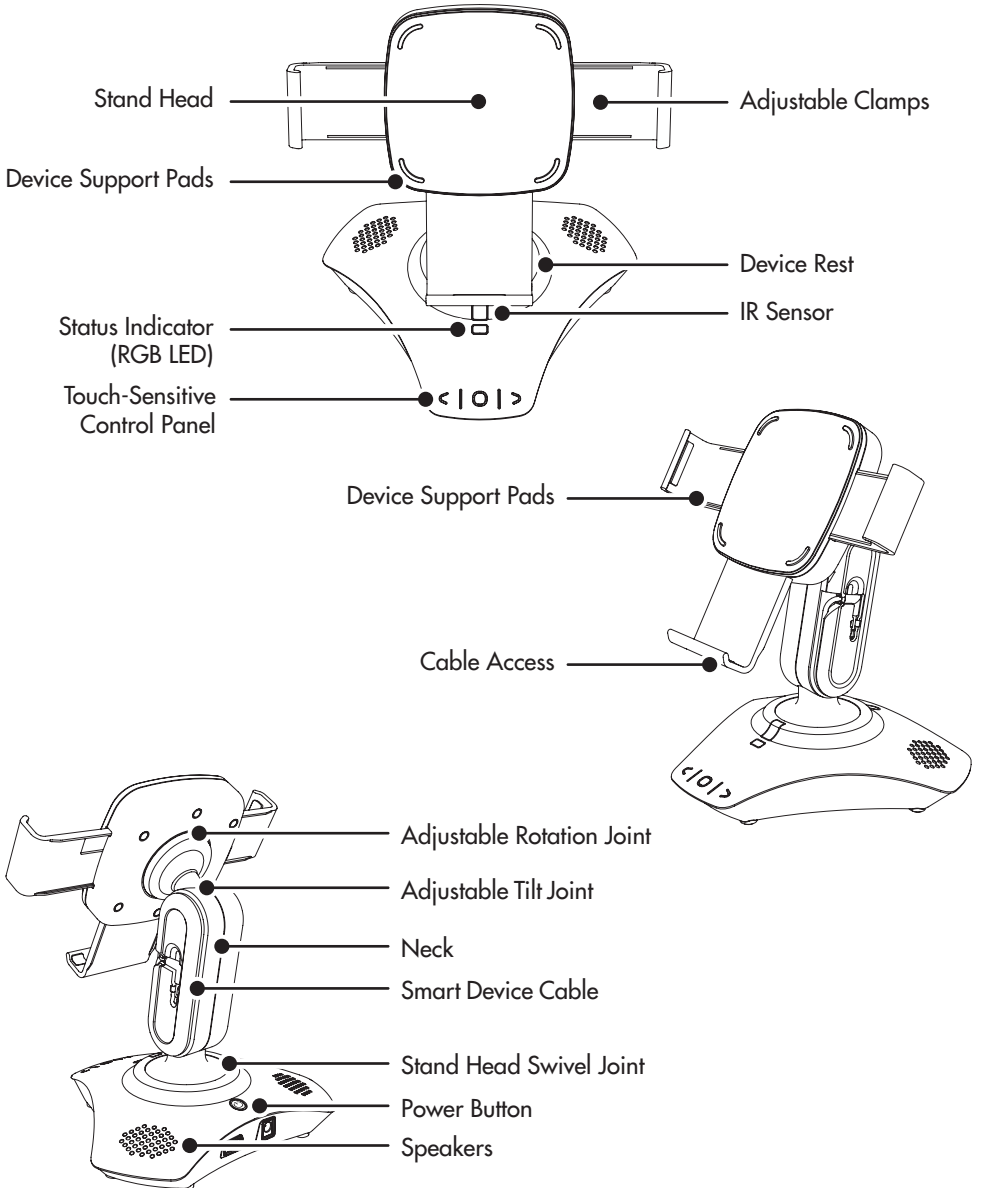

QUICK OVERVIEW

TOUCH-SENSITIVE CONTROL PANEL

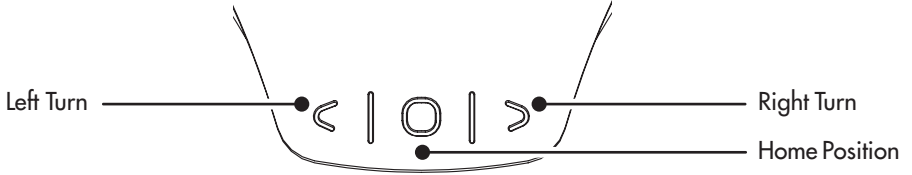

MOTORIZED BASE - REAR

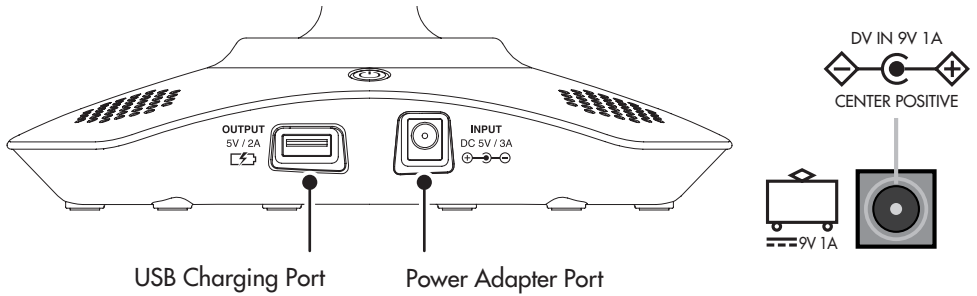

REMOTE CONTROLLER

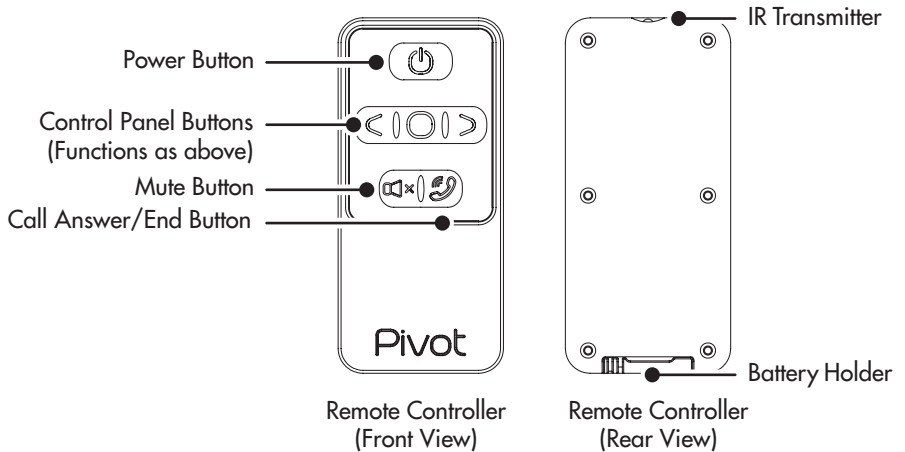

GETTING STARTED

Rovio Pivot™ acts as a stand for your tablet smart device, with a tilt neck and three-position 90° swivel clamp. Rovio Pivot™ can also turn left and right or return to the Home position, either using the Touch-Sensitive Control Panel on the base or with the Remote Controller. Other features include outputting sound through Rovio Pivot™ and charging your tablet smart device.

Setting Up The Rovio Pivot™ Unit

1. Place Rovio Pivot™ on a flat surface, making sure the feet are all evenly touching the surface.
2. Plug the AC / DC Adapter into the Power Adapter Port on the Rovio Pivot™ unit, then plug the AC / DC Adapter into a wall socket.
3. Push the "Power Button" to turn Rovio Pivot™ on.

Connecting A Tablet Smart Device

To connect Pivot to a smart device:

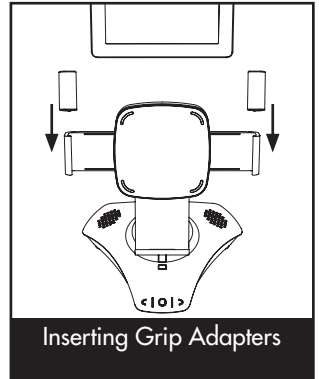
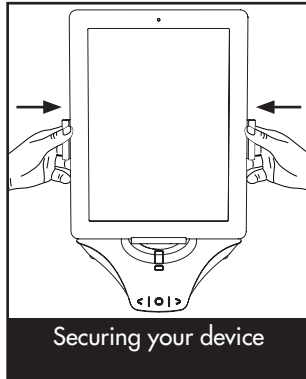
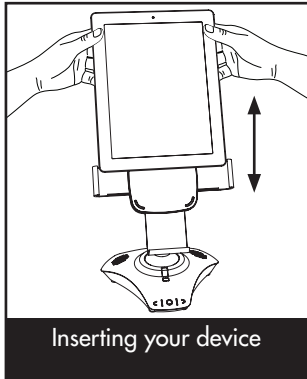

1. Gently slot your smart device into the Stand Head and push the Left and Right Adjustable Clamps together until the device is held securely*.

NOTE: Be sure to place the base of your smart device on the Device Rest.

* If you are experiencing difficulty in securing your device, insert the Grip Adapters then reclamp for a tighter fit.

GETTING STARTED

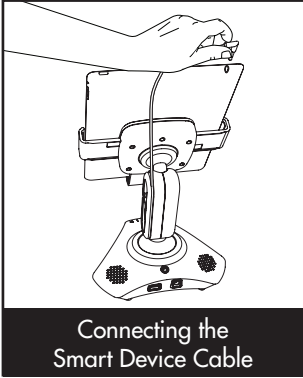

2. To ensure that sound is played back through Rovio Pivot™, insert the Smart Device Cable into the headphone jack on the smart device.

NOTE: To control the volume level, please use the buttons on your smart device.

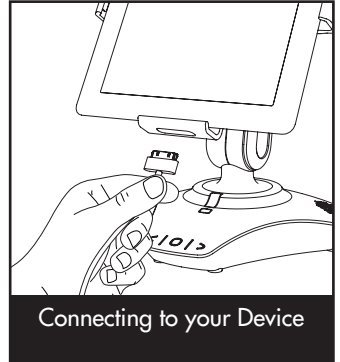
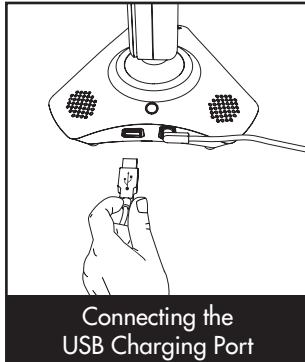
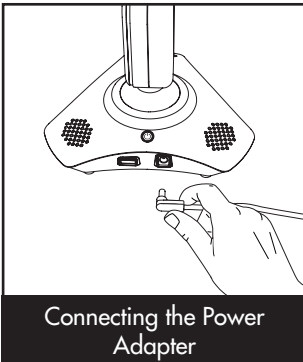

3. To charge your device via Rovio Pivot™, first check that the unit is connected to a power source using the included Power Adapter. Then, connect your USB charge cable (not included) to the USB Charging Port located on the back of the base. Insert the other end of the charge cable into your smart device and it will commence charging.

NOTE: With the Power Adapter connected, Rovio Pivot™ is capable of charging your smart device even when the unit is not switched on.

CONTROLLING ROVIO PIVOT™

Controlling Rovio Pivot™

To turn attached smart device to the left, press the “Left Turn Button”  on the Touch-Sensitive Control Panel on the unit base or on the Remote Controller.

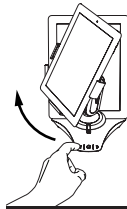

Left

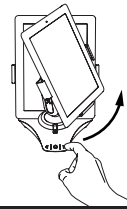

Right

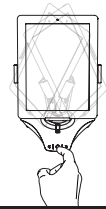

Home

To turn attached smart device to the right, press the “Right Turn Button”  on the Touch-Sensitive Control Panel on the unit base or on the Remote Controller.

To return to the Home position, press on the “Home Position Button”  on the Touch-Sensitive Control Panel on the unit base or on the Remote Controller.

Adjusting Rovio Pivot™

The viewing angle and position on Rovio Pivot™ can be adjusted manually for optimal viewing.

Adjusting Tilt – While firmly holding the top of the neck, grasp the Stand Head and gently adjust the tilt of the stand to your desired position. The Tilt Joint will friction lock into place.

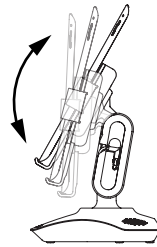

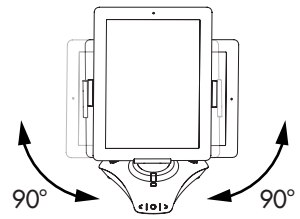

Tilt



View Modes

Adjusting Viewing Modes – To change the viewing mode from vertical to horizontal, or visa-versa, first firmly hold the top of the Neck. Then, grasp the Stand Head and gently rotate it to the desired view mode. The Stand Head will friction lock into position. Note that the Stand Head can only rotate 90° clockwise and counter-clockwise from the vertical position.

Additional Remote Controller Features

The Remote Controller also enables you to mute the sound output on the unit, remotely by pressing the “Mute Button” . Camera and microphone functions on your smart device will still be active. To use the “Call Answer/End Button” , you must be connected to another Rovio Pivot™ user via the app.

Disconnecting And Removing A Smart Device





To disconnect and remove a smart device from Rovio Pivot™, first close out of any open applications. Be sure that the Device Rest is situated to the bottom of the unit. Then, remove the headphone jack and any other cables that may be connected to your smart device. Finally, gently pull back the Left and Right Adjustable Clamps to loosen your device and carefully remove it from the unit.

STATUS INDICATOR

Status Indicator

The Rovio Pivot™ unit is equipped with a Status Indicator (RGB LED) that will change color depending on its current status.

Below is a list of status lights:

Function	Action	LED Status
Power ON 	Pressing "Power Button"	BLUE (Constant)
Power OFF 	Pressing "Power Button" (when ON)	BLUE (Fades out)
MUTE Activation 	Pressing "Mute Button"	ORANGE (Flashes on activation) then returns to BLUE
MUTE Cancellation 	Pressing "Mute Button"	GREEN (Flashes on activation) then returns to BLUE
Device CONNECTED	Successful connection between Rovio Pivot™ and smart device post hardware and software activation	BLUE (Flashes)
Device DISCONNECTED	Lost connection between Rovio Pivot™ and smart device.	RED (Flashes)

APP FUNCTIONALITY AND Q & A

DEVICE REQUIREMENTS

Rovio Pivot™ is equipped with BLE (Bluetooth® Low Energy) connectivity and can interact wirelessly with an iPad® 3 or above, iPad Air™, iPad mini™ or select Android™ BLE enabled tablet devices. Apple® devices must be running iOS 7 or above. Android™ devices must be running Android™ 4.3 BLE or above.

APP AVAILABILITY

Supporting apps are available on the App StoreSM and Google Play™. Please check periodically for any updates and/or additional apps.

Downloading the App

For iPad® and iPad mini™: Go to the App Store and search for Rovio Pivot. Alternatively, open a browser and use the following link: appstore.com/roviopivot. Then, click download.

For Android™: Go to the Google Play Store and search for Rovio Pivot. Then, click download.

Note that to use the app with Rovio Pivot™, your smart device Bluetooth function must be enabled. Follow the instructions provided within the app.

Q&A AND PRODUCT SUPPORT

Q: My Rovio Pivot™ is not responding to commands from the Remote Controller...

A: Make sure you point the Remote Controller directly at Pivot's IR Sensor on the front of the base. If there is no response, try unplugging the Power Adaptor for 5 seconds, then reconnect and restart Pivot. If there is still no response, try changing the "CR2032 3V" size alkaline battery in the Remote Controller.

Q: There is no sound coming from my Rovio Pivot™...

A: Check that you have connected your smart device to Pivot, using the Smart Device Cable connected to Pivot, which should be inserted into the headphone jack on your smart device. Check that the volume on your device is turned up.

Q: I cannot charge my device using Rovio Pivot™...

A: Check Pivot is connected to an external power source using the included Power Adapter. Then, check that the USB charge cable (not included) is connected between the Pivot base and your smart device.

Q: Rovio Pivot™ will not connect with the app on my smart device...

A: Check that the Bluetooth function on your smart device is turned on. If you are still having difficulties, try restarting both Pivot and your device.

WARRANTY

WowWee™ 90-Day Limited Warranty

WowWee's warranty obligations for Rovio Pivo™ (this "Product") are limited to the terms set forth below.

WowWee Group Limited ("WowWee") warrants to the original end-user purchaser that this Product will be free from defects in materials and workmanship under normal use for a period of 90 days from the date of retail purchase (the "Warranty Period"). This warranty is extended only to the original end-user purchaser of a new product that was not sold "as is".

If a defect arises:

(1) you may within 30 days from the date of retail purchase (or such other period specified by the return policies of the place of purchase) return this Product to the place of purchase, together with the original proof of purchase and either the original box or the UPC code label from the box, and this Product will be replaced or, in the event that a replacement for this Product is not available at the place of purchase, either a refund of the purchase price for this Product or a store credit of equivalent retail value will be provided; or

(2) you may after the day that is 30 days from the date of retail purchase (or such other period specified by the return policies of the place of purchase) and within the Warranty Period contact WowWee Customer Support to arrange for the replacement of this Product. In the event that a replacement for this Product is not available this Product will be replaced by WowWee with a product of equivalent or greater retail value.

Notwithstanding the foregoing terms of this warranty, WowWee reserves the right at all times, at its sole option and discretion, to refund to you the purchase price paid by you for this Product in full and final settlement of WowWee's obligations under this warranty.

A purchase receipt or other proof of the date of retail purchase and purchase price is required in order to claim the benefit of this warranty.

If this Product is replaced, the replacement product becomes your property and the replaced Product becomes WowWee's property. If the place of purchase refunds the purchase price of this Product or issues a store credit of equivalent retail value, this Product must be returned to the place of purchase and becomes WowWee's property. If WowWee refunds the purchase price of this Product, this Product must be returned to WowWee and becomes WowWee's property.

EXCLUSIONS AND LIMITATIONS

This warranty covers the normal and intended use of this Product. This warranty does not apply: (a) to damage caused by accident, abuse, unreasonable use, improper handling and care or other external causes not arising out of defects in materials or workmanship; (b) to damage caused by service performed by anyone who is not an authorized representative of WowWee; (c) to any hardware, software or other add-on components installed by the end-user; (d) if this Product has been disassembled or modified in any way; (e) to cosmetic damage, including but not limited to scratches, dents or broken plastic, or normal wear and tear.

THIS WARRANTY GIVES YOU SPECIFIC LEGAL RIGHTS AND YOU MIGHT ALSO HAVE OTHER RIGHTS THAT VARY FROM STATE TO STATE. WOWWEE'S RESPONSIBILITY FOR PRODUCT DEFECTS IS LIMITED TO THE REPLACEMENT OF THIS PRODUCT OR THE REFUND OF THE PURCHASE PRICE FOR THIS PRODUCT. ALL EXPRESS AND IMPLIED WARRANTIES, INCLUDING BUT NOT LIMITED TO ANY IMPLIED WARRANTIES AND CONDITIONS OF MERCHANTABILITY AND FITNESS FOR A PARTICULAR PURPOSE, ARE LIMITED IN TIME TO THE TERM OF THIS LIMITED WARRANTY. NO WARRANTIES, WHETHER EXPRESS OR IMPLIED, WILL APPLY AFTER THE EXPIRATION OF THE LIMITED WARRANTY PERIOD. If any term of this warranty is held to be illegal or unenforceable, the legality or enforceability of the remaining terms shall not be affected or impaired.

EXCEPT AS PROVIDED IN THIS WARRANTY AND TO THE EXTENT PERMITTED BY LAW, WOWWEE IS NOT RESPONSIBLE FOR DIRECT, SPECIAL, INCIDENTAL OR CONSEQUENTIAL DAMAGES HOWSOEVER CAUSED RESULTING FROM BREACH OF WARRANTY OR CONDITION OR UNDER ANY OTHER LEGAL THEORY, INCLUDING BUT NOT LIMITED TO LOSS OF USE. THE FOREGOING LIMITATION SHALL NOT APPLY TO DEATH OR PERSONAL INJURY CLAIMS, OR ANY STATUTORY LIABILITY FOR INTENTIONAL AND GROSS NEGLIGENT ACTS AND/OR OMISSIONS.

SOME STATES DO NOT ALLOW THE EXCLUSION OR LIMITATION OF INCIDENTAL OR CONSEQUENTIAL DAMAGES, OR LIMITATIONS ON HOW LONG AN IMPLIED WARRANTY LASTS, SO THESE LIMITATIONS MIGHT NOT APPLY TO YOU.

Valid only in U.S.A.



Pivot™

THE ULTIMATE TABLET STAND

Manufactured and distributed by © 2013 WowWee Group Limited. Product names, designations, and logos are trademarks or registered trademarks of WowWee Group Limited. All rights reserved.

Customer Service website:
www.wowweezone.com

We recommend that you retain our address for future reference.

Product and colors may vary.

Packaging printed in China.

Apple, the Apple logo, iPad, iPad Air and iPad mini are trademarks of Apple Inc. Registered in the U.S. and other countries. App Store is a service mark of Apple Inc.

Android and Google Play are trademarks of Google Inc.

MADE IN CHINA.

CAUTION

Changes or modifications not expressly approved by the party responsible for compliance could void the user's authority to operate the equipment.



For more information on Rovio Pivot™, go to www.wowwee.com/roviopivot

If you have any questions that are not answered in this manual, visit www.wowweezone.com

To see the full range of WowWee products, go to www.wowwee.com

NOTE

This equipment has been tested and found to comply with the limits for a class B digital device, pursuant to part 15 of the FCC rules. These limits are designed to provide reasonable protection against harmful interference in a residential installation. This equipment generates, uses and can radiate radio frequency energy and, if not installed and used in accordance with the instructions, may cause harmful interference to radio communications.

However, there is no guarantee that interference will not occur in a particular installation. If this equipment does cause harmful interference to radio or television reception, which can be determined by turning the equipment off and on, the user is encouraged to try and correct the interference by one or more of the following measures:

- Reorient or relocate the receiving antenna
- Increase the separation between the equipment and receiver
- Connect the equipment into an outlet on a circuit different from that to which the receiver is connected
- Consult the dealer or experienced radio/TV technician for help

This Device complies with Part 15 of the FCC Rules. Operation is subject to the following two conditions: (1) This device may not cause harmful interference, and (2) This device must accept any interference received, including interference that may cause undesired operation.

This device complies with Industry Canada Licence-exempt RSS-210. Operation is subject to the following two conditions: (1) this device may not cause interference, and (2) this device must accept any interference, including interference that may cause undesired operation of the device.

This equipment must be installed and operated in accordance with provided instructions and the antenna(s) used for this transmitter must be installed to provide a separation distance of at least 20 cm from all persons and must not be co-located or operating in conjunction with any other antenna or transmitter. End-users and installers must be provided with antenna installation instructions and transmitter operating conditions for satisfying RF exposure compliance.

For these purposes, the party responsible is:

WowWee USA Inc.
875 Prospect Street
Suite 204A
La Jolla, CA 92037

1-800-310-3033

WARNING! This equipment may experience difficulty and/or memory loss when subjected to any electrostatic discharge, radio frequency interference, or sudden power surge/interruption. The user is encouraged to reset the equipment should any of these occur.



WowWee Group Limited
Energy Plaza, 301A-C
92 Granville Road
T.S.T. East, Hong Kong

WowWee Canada Inc.
3700 Saint Patrick Street,
Suite 206,
Montreal, QC, H4E 1A2, Canada

Digital Download