

# **Users Manual**

## **Manual AMB2300**

---

Version 1.3

## **BlueNiceCom 4**

Development department  
AMBER wireless GmbH  
Hawstraße 2a  
D-54290 Trier  
Tel. +49 (0) 651-99355-0  
Fax +49 (0) 651-99355-69

## Table of contents

<b>1</b>	<b>General .....</b>	<b>3</b>
<b>2</b>	<b>Technical data.....</b>	<b>3</b>
	<b>2.1 DEFAULT SETTINGS .....</b>	<b>4</b>
	<b>2.2 PIN ASSIGNMENT .....</b>	<b>4</b>
	2.2.1 Pinning.....	4
	2.2.2 Pinning table .....	5
	2.2.3 Serial interface of the BlueNicecom 4.....	6
	2.2.4 Block diagram .....	7
	<b>2.3 DIMENSION.....</b>	<b>8</b>
<b>3</b>	<b>Details for Layout .....</b>	<b>9</b>
<b>4</b>	<b>Soldering &amp; Reflow .....</b>	<b>9</b>
	<b>4.1 DESCRIPTION .....</b>	<b>9</b>
	<b>4.2 RECOMMENDATION FOR FOOTPRINTS .....</b>	<b>10</b>
<b>5</b>	<b>Replace of BNC3 to BNC4 .....</b>	<b>11</b>
<b>6</b>	<b>Minimum connection to run the BNC4 .....</b>	<b>11</b>
<b>7</b>	<b>Further documents .....</b>	<b>11</b>
<b>8</b>	<b>External antenna.....</b>	<b>12</b>
<b>9</b>	<b>Declaration of Conformity .....</b>	<b>13</b>
<b>10</b>	<b>Important notes.....</b>	<b>14</b>
	<b>10.1 COMPLIANCE STATEMENT .....</b>	<b>14</b>
	<b>10.2 DISCLAIMER.....</b>	<b>15</b>
	<b>10.3 TRADEMARKS .....</b>	<b>15</b>
	<b>10.4 LIMITATION OF USE .....</b>	<b>15</b>

# 1 General

## BlueNiceCom 4 Bluetooth-Modul with UART-interface and integrated Chip-antenna

- Bluetooth Class 2 module
- Bluetooth Specification 2.0 compatible
- Support of Bluetooth Audio
- Integrated profiles: SPP, GAP, SDAP
- Supported profiles: DUN, OBEX, HSP etc.
- UART interface
- Integrated chip antenna



Abb. 1

AMBER wireless provides with the BlueNiceCom 4 a certified, qualified listed Bluetooth-module, based on LMX9830 from National Semiconductor. This compact and inexpensive Bluetooth-module is qualified for a serial data or audio transmission. The module has an integrated chip-antenna and can be placed into a circuit like a SMD-part.

BlueNiceCom IV comes with an integrated firmware with the complete Bluetooth Stack (Bluetooth 2.0).

A Point-to-Point connection and a Point-to-Multipoint (Piconet) connection are supported by the firmware. Up to seven active links (Piconet) and one SCO-link (Audio) is possible.

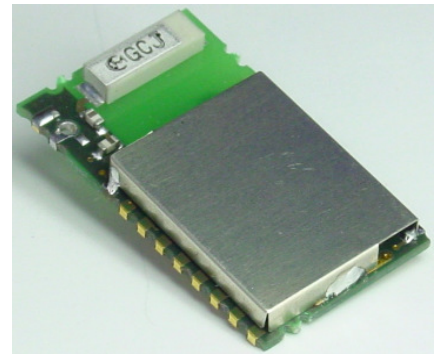
The module can be integrated easily in a system. According to the application and the settings the BlueNiceCom 4 can work as a stand-alone-slave-module e.g. as a virtual cable replacement in combination with another commercial Bluetooth system.

A development environment AMB2300-EV is available.

## 2 Technical data

Voltage supply	2.9 to 3.3V
Current consumption	typ. 65mA
RF output	typ. 0dBm (Class 2)
Rx sensitivity	typ. -80dBm
Data rate UART	2,4 to 921,6 kbits/s
Operating temperature	-20 °C to 70 °C
Antenna	Integrated chip antenna Connection of an external antenna is possible
Dimension	27,5 x 16 x 3,5mm
Miscellaneous	All further technical datas according to the LMX9830 module of National Semiconductor
Order number	AMB2300
Part code:	BlueNiceCom 4

## 2.1 Default settings

All parameter are stored at the internal EEPROM.  
See datasheet LMX9830

Parameter	EEPROM Address	Default set ups	Notice
DeviceName length	0018	18	Device Name + NULL-Terminierung
DeviceName	0019 – 0040	<Variabel>	Device Name Consist of „BNC4-“ and BD_ADDR

## 2.2 Pin assignment

### 2.2.1 Pinning

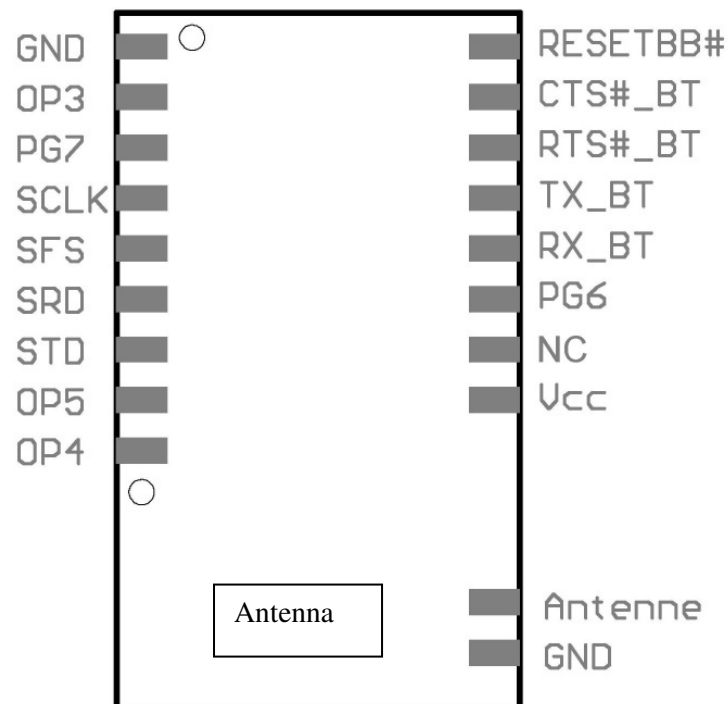

Figure. 2

## 2.2.2 Pinning table

Pin name	Typ <sup>1</sup>	Notice
GND	I	Ground
OP3	I	At start up configuration of the UART-data rate, otherwise internal use
PG7	I/O	GPIO (default setting as output, display a data exchange)
SCLK	I/O	Audio PCM Interface Clock
SFS	I/O	Audio PCM Interface Frame Synchronization
SRD	I	Audio PCM Interface Receive Data Input
STD	O	Audio PCM Interface Transmit Data Output
OP5	I	Configuration UART-data rate at Start up
OP4	I/O	Configuration UART-data rate at Start up, otherwise GPIO
RESETBB#	I	Reset, internal Pull up, active low
CTS#_BT	I	Host Serial Port Clear To Send, active low <sup>2</sup> - see footnote 2
RTS#_BT	O	Host Serial Port Request To Send, active low <sup>3</sup> - see footnote 3
TX_BT	O	Host Serial Port Transmit Data
RX_BT	I	Host Serial Port Receive Data
PG6	I/O	GPIO (default setting as output, display a link connection)
NC	I	Not connected, no ground
Vcc	I	Power consumption, 2,9V to 3,6V
Antenna	O	Connection for external antenna <sup>4</sup> - see footnote 4
GND	O	

The signal level is equivalent to the power consumption (2,9V to 3,6V) of the BlueNiceCom 4 and has to be matched, if the Host system is working with a different signal level.

<sup>1</sup> I = Input, O = Output

<sup>2</sup> Connect with ground if not used

<sup>3</sup> Not connected if not used

<sup>4</sup> In as-delivered condition the antenna connection is internally not connected

OP3, OP4, OP5:

Configuration of the serial interface. Must be connected.

OP3	OP4	OP5	Function
0	1	0	Automatically baud rate-detection
1	0	0	Baud rate-adjustment is read from the EEPROM
1	0	1	9600 bps
1	1	0	115200 bps
1	1	1	921600 bps

RX\_BT, TX\_BT, RTS#\_BT, CTS#\_BT:

### 2.2.3 Serial interface of the BlueNicecom 4.

The interface serves for communication with the BlueNiceCom4. The hardware handshake is used (RTS/CTS). If this should not be supported by the host system, RTS#\_BT and CTS#\_BT must be short circuit and/or CTS#\_BT put on Low levels

This can lead however to overrun! We recommended therefore urgently to use handshake.

ResetBB#: Internal Pull up, low active. No external circuit is necessary.

SCLK, SFS, SRD, STD: Audio interface. If not used, Pins does not attached

PG6 , PG7: I/O Ports. If not used, Pins does not attached

Vcc, Gnd Power consumption

## 2.2.4 Block diagram

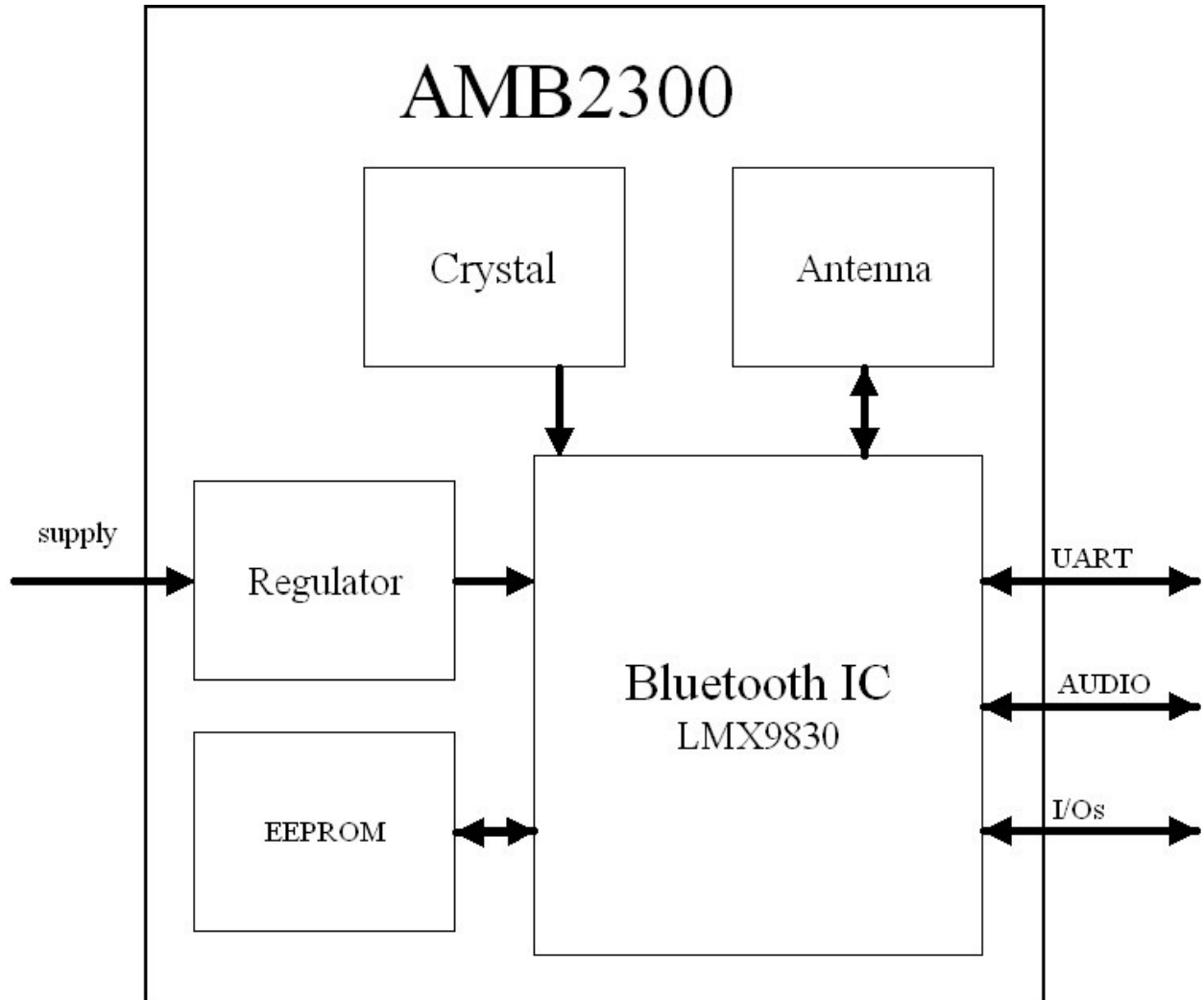



### 2.3 Dimension

BlueNiceCom IV has 1mm x 2mm soldering pads with a raster of 2mm to be solder direct on a motherboard

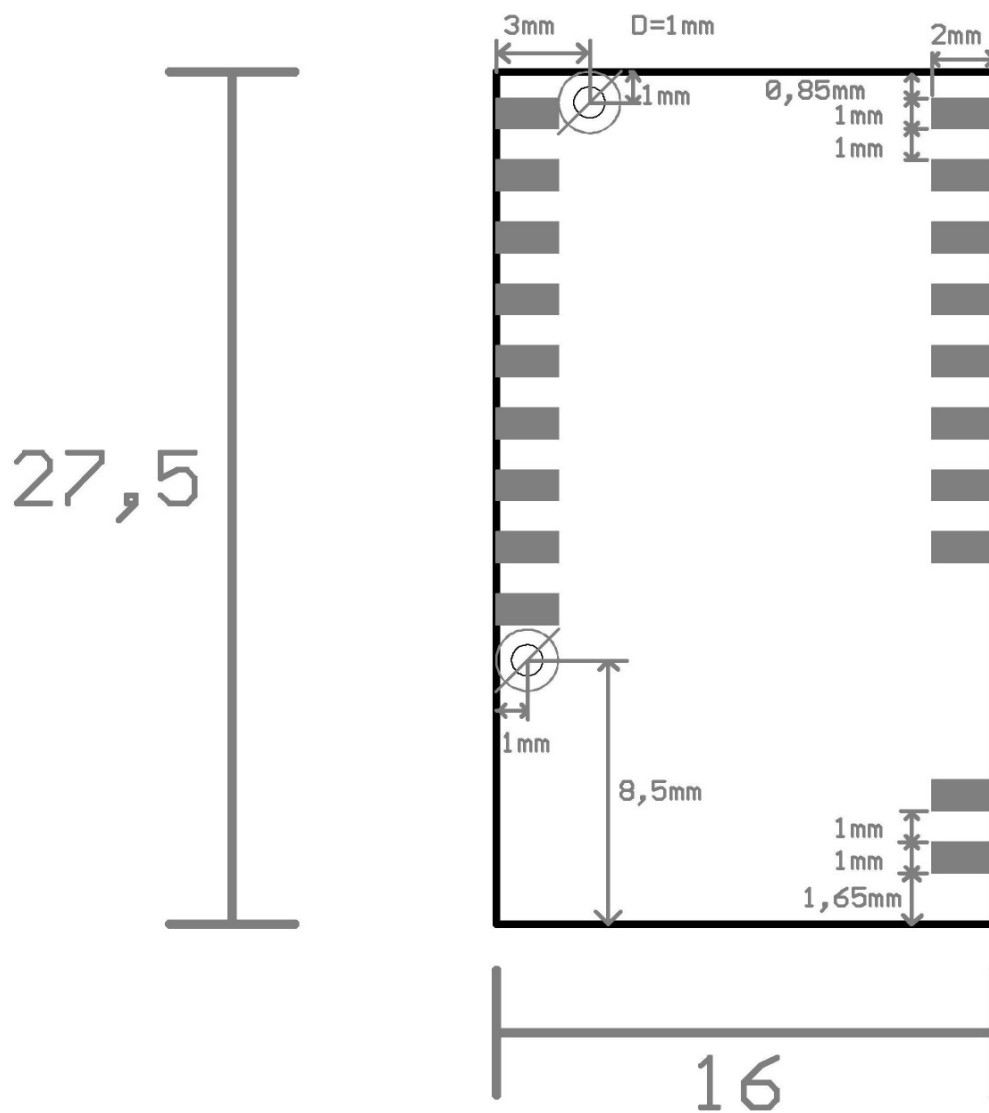

### 3 Details for Layout

To achieve the maximum of range no metal has to be near or under the antenna. The antenna should have a distance of 8mm to any ground, strip line or component. Most suitable is to place the antenna at the margin of the motherboard. The figure shows the area which should be free of metal (ground, strip line, components, etc..).

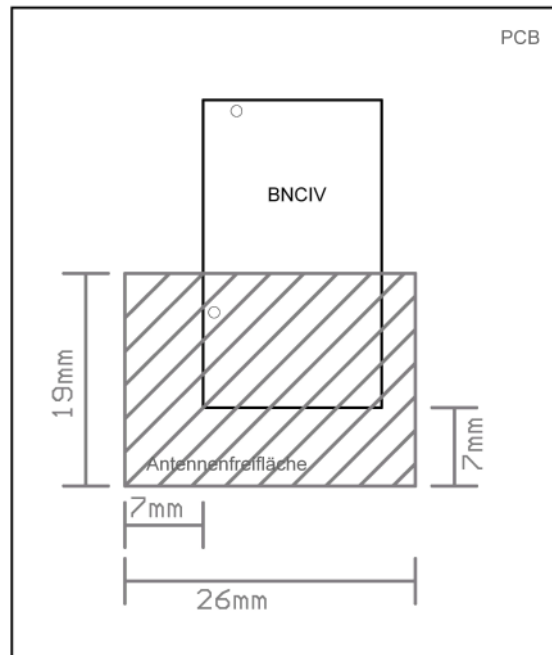

The area off 12mm between the soldering pads on the bottom side should (e.g. with adhesive tape) additional isolated, if any strip line is under the module to avoid any short circuit.

## 4 Soldering & Reflow

### 4.1 Description

- Reflow appropriate
- The temperature curve depends on the motherboard it's character, like the number and conditioning of parts, etc. Please ask your manufacturer.
- Depending on the limit values of the components following limits are not allowed to excess

260°C max. 40s (LMX)  
 250°C max. 20s (Chip-antenna)  
 200°C max. 120s (Chip-antenna)

#### 4.2 Recommendation for Footprints

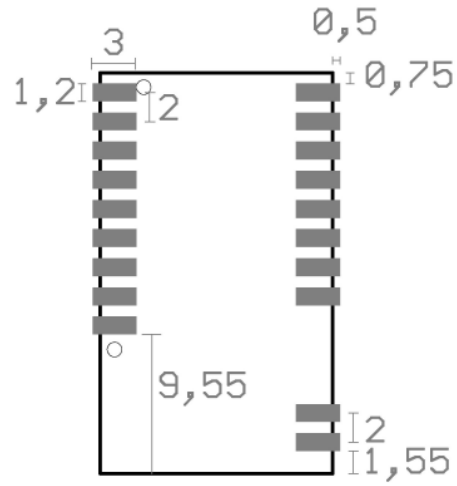

All dimensions in mm

## 5 Replace of BNC3 to BNC4

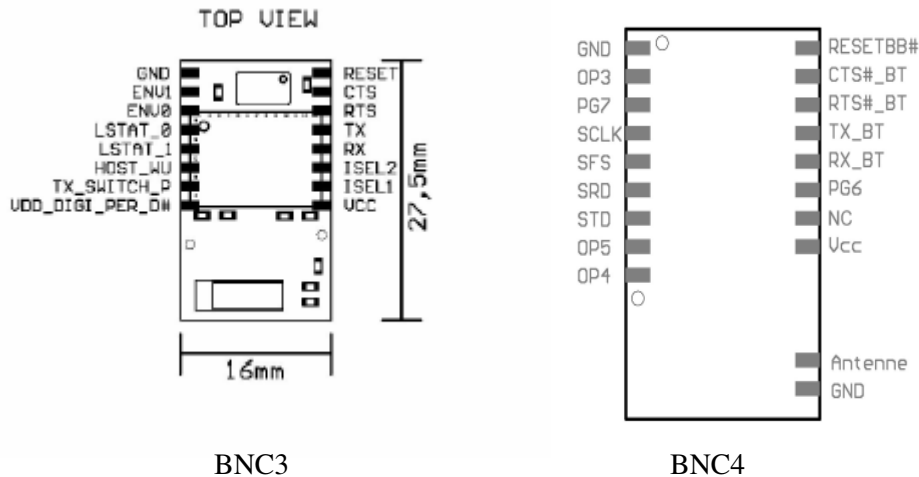

CTS, RTS, TX, RX,	no change (UART)
Vcc, GND	no change
Reset	At BNC4 no external connection necessary
ISEL2	PG6 (I/O) no connection necessary
ISEL1	N.C. Pin not connected!
ENV1	OP3 (Input) must be connected because of UART configuration
ENV0	PG7 (I/O) no connection necessary
LSTAT_0, LSTAT1	Audio interface, no connection necessary (PG6 fulfils function of LSTAT_1)
Host_WU	Audio interface, no connection necessary
TX_Switch_p	Audio interface, no connection necessary (PG7 fulfils these function now)
VDD_DIGI_PER_D	OP5 (Input) must be connected because of UART configuration
---	OP4 (Input) must be connected because of UART configuration

## 6 Minimum connection to run the BNC4

Vcc, GND	- Power consumption
RX, TX	- UART
RTS, CTS	- UART short circuit, danger of data overrun
OP3, OP4, OP5	- Configuration UART, connecting without pullup or pulldown resistors

All other PIN's doesn't need to be connected.

## 7 Further documents

Data sheet LMX9830  
 Software User Guide  
 Simply Blue Commander (Windows Software)

## 8 External antenna



The AMB2300 can be operated also with an external antenna. In addition the red marked condenser (100pF 0603) must, as are changed above shown in its position. The lateral antenna connection is available then for a coaxial cable or a wire antenna.

**These steps should accomplish attention, only persons with good HF knowledge, since this kind of connection can involve high error potential!  
By these measures the warranty and the permission expire.**

## 9 Declaration of Conformity



### DECLARATION OF CONFORMITY Directive 1999/5/EG (R&TTE)

**The manufacturer:** AMBER wireless GmbH  
Albin-Köbis-Straße 18  
51147 Köln  
Tel. ++49-2203-699-1950

declares on our sole responsibility, that the following product:

**Type-designation:** **BlueNiceCom 4 (AMB2300)**

**Intended purpose:** 2,4GHz-Bluetooth™ wireless data modem  
Transfer of digital messages

complies with the appropriate essential requirements of article 3 of the R&TTE 1999/5/EG directive, if used for its intended purpose and that the following norms, standards or documents has been applied:

EN 300 328-1, -2 (2001-12)  
EN 301 489-1, -17 (2002-04)  
EN 50371 (2002)  
EN 60950 (2001-12)

Köln, 23.2.2006  
place and date of issue

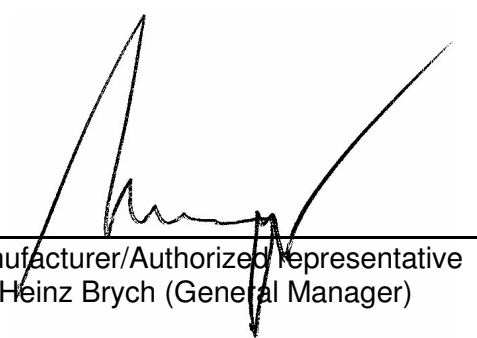

\_\_\_\_\_  
Manufacturer/Authorized Representative  
Heinz Brych (General Manager)

## 10 Important notes

### 10.1 Compliance statement

#### USA

This device complies with Part 15 of the FCC Rules. Operation is subject to the following two conditions:

- (1) This device may not cause harmful interference, and
- (2) this device must accept any interference received, including interference that may cause undesired operation.

Usually this is followed by the following FCC caution:

Any changes or modifications not expressly approved by the party responsible for compliance could void the user's authority to operate this equipment.

#### Canada

Operation is subject to the following two conditions: (1) this device may not cause interference, and (2) this device must accept any interference, including interference that may cause undesired operation of the device.

Usually this is followed by the following RSS caution:

Any changes or modifications not expressly approved by the party responsible for compliance could void the user's authority to operate this equipment.

## 10.2 Disclaimer

AMBER wireless GmbH believes the information contained herein is correct and accurate at the time of this printing. However, AMBER wireless GmbH reserves the right to change the technical specifications or functions of its products, or to discontinue the manufacture of any of its products or to discontinue the support of any of its products, without any written announcement and urges its customers to ensure, that the information at their disposal is valid. AMBER wireless GmbH does not assume any responsibility for the use of the described products, neither does it convey any license under its patent rights, or its other intellectual property rights, or any third party rights. It is the customer's responsibility to ensure that his system or his device, in which AMBER wireless products are integrated, complies with all applicable regulations.

## 10.3 Trademarks

AMBER wireless® is a registered trademark owned by AMBER wireless GmbH. All other trademarks, registered trademarks and product names are the sole property of their respective owners.

## 10.4 Limitation of Use

AMBER wireless products are not authorised for use in life support appliances, devices, or other systems where malfunction can reasonably be expected to result in significant personal injury to the user, or as a critical component in any life support device or system whose failure to perform can be reasonably expected to cause the failure of the life support device or system, or to affect its safety or effectiveness. AMBER wireless GmbH customers using or selling these products for use in such applications do so at their own risk and agree to fully indemnify AMBER wireless GmbH for any damages resulting from any improper use or sale.

Use of AMBER wireless products commits the user to the terms and conditions set out herein.

© 2005, AMBER wireless GmbH. All rights reserved.

## **AMBER wireless GmbH**

**Albin-Köbis-Straße 18**

**51147 Köln**

**Tel. 02203-6991950**

**Fax 02203-459883**

**eMail [info@amber-wireless.de](mailto:info@amber-wireless.de)**

**Internet <http://www.amber-wireless.de>**