

**Model 400**

**B/W Reflection  
Densitometer**

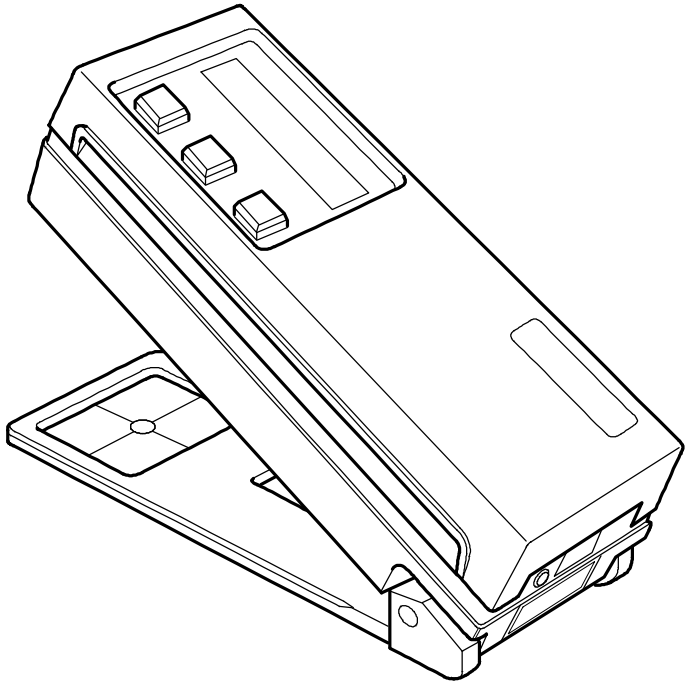

**Operation Manual**

**X-Rite** 

The X-Rite logo consists of the brand name "X-Rite" in a bold, serif font, followed by a stylized graphic of three overlapping bell curves of varying heights and positions, representing a spectral or density distribution.



Dear Customer:

Congratulations! We at X-Rite, Incorporated are proud to present you with the X-Rite 400 B/W Reflection Densitometer. This instrument represents the very latest in microcontrollers, integrated circuits, optics, and display technology. Your X-Rite 400 is a rugged, reliable, finely engineered instrument whose performance is unsurpassed.

To fully appreciate and protect your investment, we suggest that you take the necessary time to read and fully understand this manual. As always, X-Rite stands behind your 400 with a full one year limited warranty and a dedicated service organization. If the need arises, please don't hesitate to call us.

Thank you for your trust and confidence.

X-Rite, Incorporated

## **CE DECLARATION**

Manufacturer's Name: X-Rite, Incorporated  
Manufacturer's Address: 3100 44<sup>th</sup> Street, S.W.  
Grandville, Michigan 49418  
U.S.A.

Model Name: Densitometer  
Model No.: 400

Directive(s) Conformance: EMC 89/336/EEC LVD 73/23/EEC

---

**NOTE:** The device complies to the product specifications for the Low Voltage Directive when furnished with the 230VAC AC Adapter (X-Rite P/N SE30-62), and to UL Standards when furnished with the 115VAC AC Adapter (X-Rite P/N SE30-61).

---

# FEDERAL COMMUNICATIONS COMMISSION NOTICE

## FCC Statement

This equipment has been tested and found to comply with the limits for a Class A digital device, pursuant to Part 15 of the FCC Rules. These limits are designed to provide reasonable protection against harmful interference when the equipment is operated in a commercial environment. This equipment generates, uses, and can radiate radio frequency energy and, if not installed and used in accordance with the instruction manual, may cause harmful interference to radio communications. Operation of this equipment in a residential area is likely to cause harmful interference in which case the user will be required to correct the interference at his own expense.

## Canada

This Class A digital apparatus meets all requirements of the Canadian Interference-Causing Equipment Regulations.

Cet appareil numérique de la classe A respecte toutes les exigences du Règlement sur le matériel brouilleur du Canada.

The Manufacturer:	X-Rite, Incorporated
Der Hersteller:	3100 44th Street, S.W.
El fabricante:	Grandville, Michigan 49418
Le fabricant:	
Il fabbricante:	

Declares that:	Densitometer
gibt bekannt:	400
advierte que:	
avertit que:	
avverte che:	

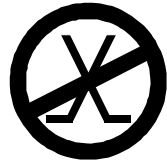

is not intended to be connected to a public telecommunications network.  
an ein öffentliches Telekommunikations-Netzwerk nicht angeschlossen werden soll.  
no debe ser conectado a redes de telecomunicaciones públicas.  
ne doit pas être relié à un réseau de télécommunications publique.  
non deve essere connesso a reti di telecomunicazioni pubblici.

**CAUTION:** Operational hazard exists if AC adaptor other than X-Rite SE30-61 (115V) or SE30-62 (230V) is used.

**VORSICHT:** Betriebsgefahr besteht bei Gebrauch von anderen Adaptern als X-Rite SE30-61 (115 U) oder SE30-62 (230 U).

**AVISO:** No use otro adaptador C.A. que no sea la pieza X-Rite SE30-61 (115V) o SE30-62 (230V), por el riesgo de mal funcionamiento del equipo.

**ATTENTION:** Ne pas utiliser d'adaptateur autre que SE30-61 (115V) ou SE30-62 (230V) de X-Rite au risque de mauvais fonctionnement de l'appareil.

**AVVISO:** Non usare un altro adattatore C.A. che non è del pezzo X-Rite SE30-61 (115V) o SE30-62 (230V), per il rischio di malfunzionamento dell'apparecchio.

---

**NOTE:** Shielded interface cables must be used in order to maintain compliance with the desired FCC and European emission requirements.

**WARNING:** This instrument is not for use in explosive environment.

**WARNUNG:** Das Gerät darf in einer explosiven Umgebung NICHT verwendet werden.

**ADVERTENCIA:** NO use este aparato en los ambientes explosivos.

**ATTENTION:** Cet instrument NE DOIT PAS être utilisé dans un environnement explosif.

**AVVERTIMENTO:** NON usare questo apparecchio in ambienti esplosivi.

---

**USE ONLY:** AA NiCad batteries that are 600/700mAh rated, six required. Other types may burst causing personal injury.

**VORSICHT:** Verwenden Sie nur AA NiKad Akkus von 600/700mAh (Milliampere/Stunde) Nennstrom, 6 Stück erforderlich. Mit anderen Akkus besteht Explosions- und Verletzungsgefahr.

**ATENCION:** Use solamente las pilas de AA NiCad (se requiere seis) con condiciones de funcionamiento normales 600/700mAh (horas miliamperios). Es posible que los otros tipos puedan estallar y causar daños corporales.

**ATTENTION:** Utiliser seulement les batteries NiCad à courant nominal de 600mAh (milliampère/heure) (6 pièces nécessaire). Il y a danger d'explosion et de blessures avec les autres types.

**ATTENZIONE:** Usare solamente gli accumulatori al AA NiCad (si richiede sei) con le condizioni di funzionamento normali 600/700mAh (ore milliamperi). E possibile che altri tipi possano scoppiare e causare danno personale.

# Contents

<b>1 Overview and Setup</b>	
Features.....	1-1
Packaging and Parts .....	1-3
Instrument Vocabulary .....	1-4
Unlocking/Locking the Shoe .....	1-5
Batteries and Power .....	1-6
Adjusting the Display Angle.....	1-9
I/O Port Setup .....	1-10
<b>2 Calibration</b>	
Response Settings .....	2-1
Overview of Calibration Procedures .....	2-2
Long Calibration .....	2-3
Quick-Cal™ .....	2-4
<b>3 Density Functions</b>	
Selecting Density Function .....	3-2
Density Measurement.....	3-2
Density Difference Measurement .....	3-3
Miscellaneous Display Messages .....	3-4
<b>4 Dot Functions</b>	
Dot Formula .....	4-1
Selecting Dot Area or Dot Gain .....	4-4
Dot Area Function .....	4-5
Dot Gain Function .....	4-7
<b>5 Range Functions</b>	
Reference Value .....	5-1
Absolute Range Measurement .....	5-2
Range Minus Reference Measurement.....	5-2
<b>6 Technical Information</b>	
Serial Interface Information .....	6-1
Instrument Specifications .....	6-4
Accessories.....	6-6
General Cleaning .....	6-7
Optics Maintenance.....	6-7
Target Window Replacement .....	6-8
Lamp Replacement.....	6-9

## **7 Appendices and Index**

Proprietary Notice .....	7-1
Limited Warranty.....	7-2
Index.....	7-3

Copyright 1998 by  
X-Rite, Incorporated  
“ALL RIGHTS RESERVED”

X-Rite is a registered trademark and Quick Cal™, Q Cal™, Electronic Function Selection™, Computerized Color Response™, and CCR™, are trademarks of X-Rite, Incorporated. All other logos, brand names, and product names are the properties of their respective holders.





Features .....	1-1
Packaging and Parts.....	1-3
Instrument Vocabulary .....	1-4
Unlocking/Locking the Shoe.....	1-5
Batteries and Power.....	1-6
Adjusting the Display Angle .....	1-9
I/O Port Setup.....	1-10

The X-Rite 400 B/W Reflection Densitometer is designed to meet the quality control needs of the general graphic arts, phototypesetting, and newspaper industries. This completely portable instrument features different measurement modes for quickly measuring ink density, density difference, dot area, and dot gain. Measurements are taken with simple hand-held operation, and measurement data is clearly read on the interactive display. The three control buttons make measurement mode selection easy.

## FEATURES

The X-Rite 400 features several state-of-the-art technologies that place the instrument a step above competitive instruments in terms of accuracy, speed, and simplicity:

### **QuickCal™ One-Step Calibration**

The 400's Quick-Cal feature makes calibration fast and easy. You simply select the "Q-Cal" mode on the instrument, then measure the white patch on the supplied calibration target card. You can also get complete agreement with other densitometers using the three-color response calibration.

### **DEN (Density)**

The DEN function allows you to take absolute density and density difference measurements.

### **DOT**

The DOT function allows Dot area and Dot gain measurements. Dot is calculated with paper subtracted out using the Murray-Davies or Yule-Nielson formulas.

### **Range**

Range subtracts the lowest measurement from the highest and displays the difference. Range-Reference subtracts a reference value from the range and displays the difference.

### **Nonvolatile Memory**

A lithium battery stores calibration data and measured values when the densitometer's primary rechargeable batteries are depleted or removed.

### **Additional Features**

- **Large LCD display** clearly identifies measurement data and mode function. No need for numeric codes to identify this information.
- **Three large buttons** place all function controls at operator's fingertips.
- **AC adapter** is provided to allow readings while batteries are being recharged.
- **Two-way RS-232 interface** operates at 1200 baud, or one of several other baud rates.

## **PACKAGING AND PARTS**

After removing the instrument from the shipping carton, inspect for possible damage. If any damage is noted, contact the transportation company immediately. Do nothing more until the carrier's agent has inspected the damage.

If damage is not evident, check to ensure that all items are included (refer to the parts list below).

### **Your Package Should Include...**

- 1 400 B/W Reflection Densitometer
- 1 Carrying Case
- 1 Operation Manual
- 1 Reflection Calibration Reference 400-62
- 1 Warranty Registration Card
- 1 P/N SE30-61 Battery Charger, 115V  
*or* P/N SE30-62 Battery Charger, 230V
- 1 P/N SD01-41 Certificate of Calibration

Along with this Operation Manual, several important notices are included. You should read each of these notices before using the instrument.

### **Return Packaging**

Your X-Rite 400 was packaged in a carton specially designed to prevent damage. If re-shipment is necessary, the instrument should be re-packaged in the original carton. If the original carton is not available, a new one can be obtained from X-Rite.

**INSTRUMENT VOCABULARY**

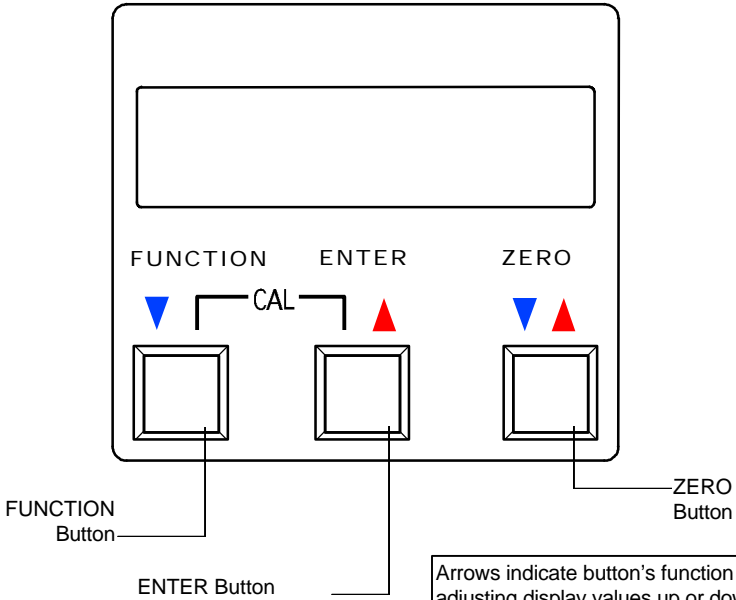
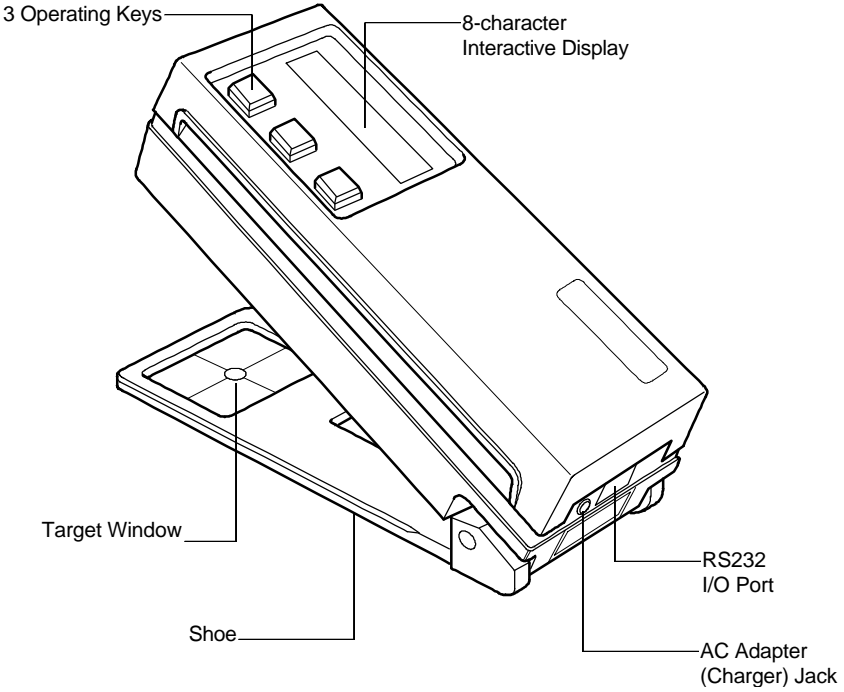

## UNLOCKING/LOCKING THE SHOE

To take measurements with the instrument, you must unlock the Shoe (see Instrument Vocabulary drawing in previous chapter). When the instrument is not in use, the Shoe should be re-locked to protect the instrument optics.

A sliding button on the bottom of the instrument locks the Shoe closed.

To unlock, hold Shoe against the unit and slide the lock button back until the button latch clears the Shoe tab. Carefully release the Shoe to open. (Figure 1-1)

To lock, hold the Shoe against the unit and slide the lock button forward until the button latch captures the Shoe tab. (Figure 1-2)

**Figure 1-1**

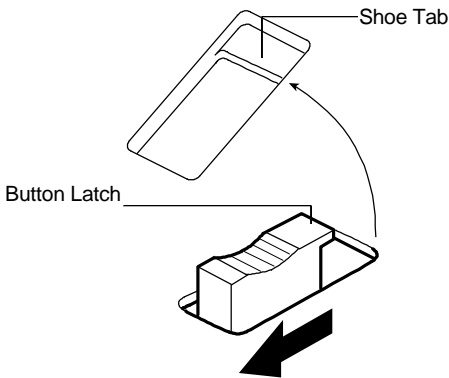

**Figure 1-2**

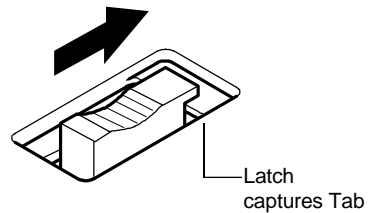

## **BATTERIES AND POWER**

Your 400 instrument's batteries should be charged before use. It can be operated while the batteries are being charged.

Before you begin charging, you must remove the battery isolation insert protruding from the battery cover. (Figure 1-3)

**Figure 1-3**

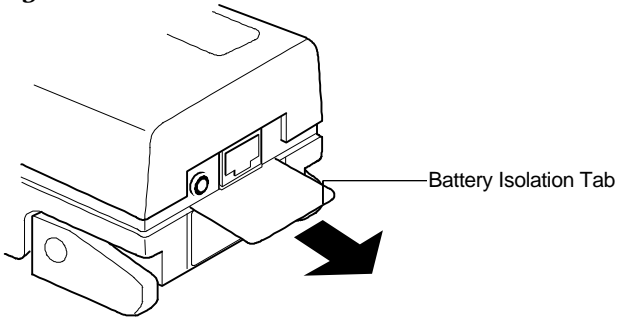

---

**NOTE:** Make sure the voltage indicated on the AC adapter complies with the AC line voltage in your area. If it does not, contact your X-Rite dealer.

---

### **To charge the battery:**

1. Plug the AC Adapter Line Cord into the AC Adapter Jack on back of instrument. (Figure 1-4)
2. Plug AC Adapter into AC wall outlet.

You can use the instrument while it recharges. The instrument will be fully charged in approximately 14 hours.

**Figure 1-4**

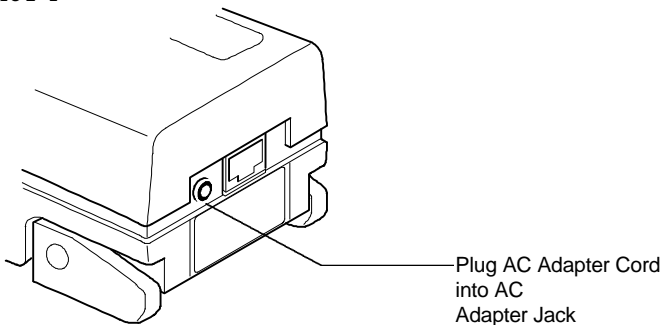

**NOTE:** If your unit has not been used for several weeks recharge for approximately 24 hours.

**NOTE:** When storing the unit for a long period of time, the batteries should be removed.

---

### **Applying Power**

The instrument remains “powered down” until a measurement is taken. When a measurement is taken, or when any key is pressed, the instrument automatically turns on.

If no measurements are taken or keys pressed for 45 seconds, the instrument automatically turns off again to conserve battery power.

### **Inserting/Removing the Batteries**

Your instrument is shipped with six AA NI-CAD batteries already installed. Should you ever need to replace the batteries, first close and lock the Shoe (when the shoe is unlocked and open, it blocks the battery door). Next, slide the battery door in the rear of the instrument down and off. The batteries will spring out a bit.

To replace the batteries, insert six fresh AA NI-CAD batteries into the instrument, three into each chamber. **Note the proper polarity of the batteries in Figure 1-5, and on the CAUTION label beneath the instrument.** You will need to press and hold the batteries down in place while you slide the battery cover back on. Push the cover into place until it is flush with the bottom of the instrument.



**400 B/W Reflection Densitometer**

*Figure 1-5*

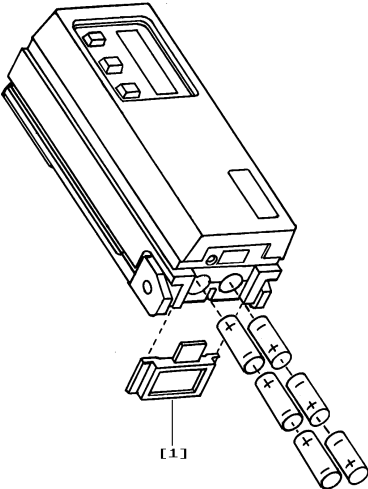

## ADJUSTING THE DISPLAY ANGLE

You can most clearly read the LCD display by viewing it at a 90° angle. The angle of the display can be adjusted to accommodate this for different user sight lines.

### To adjust the display angle:

1. Set the Display Angle Adjustment Knob on the right side of the instrument to its midpoint setting. (Figure 1-6)

**Figure 1-6**

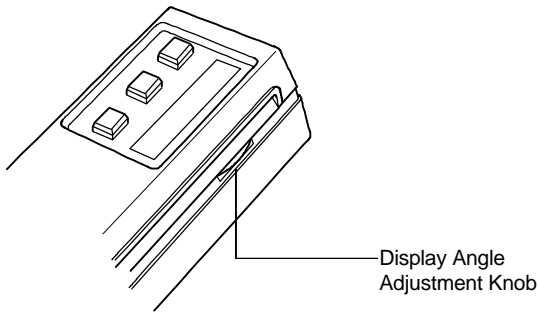

2. Activate the display by taking a measurement or pressing a control button.
3. Adjust the Display Angle Adjustment Knob until the displayed data can be most clearly seen from your line of sight.

## I/O PORT SETUP

Your X-Rite 400 has a serial port that allows data to be transmitted to—or received from—an external device. With this I/O connection made, the 400 can controlled externally by Serial Input Commands.

If you do not plan to use the I/O port at this time, you can skip ahead to Chapter 2, “Calibration.”

You can configure different functions of your I/O port using the instrument’s MODE selection procedures. You can set up:

- The desired Baud rate (output rate of characters per second) for transmitting data via the I/O port;
- the desired header (HDR) that will appear above the transmitted or printed data; and
- the desired computer output format (COMP).

### To set up the I/O port:

1. Press the FUNCTION button and the ENTER button simultaneously, then release.

*N cal X Y* appears in the display, where “X” represents the installed response (*B or R*).

N cal X Y

2. Press FUNCTION to indicate no, you do not want to calibrate. *N mode Y* appears in the display.

N mode Y

3. Press ZERO to indicate yes, you do want to set mode.  $\wedge$  I/O Y appears in the display.

$\wedge$  I/O Y

4. Press ZERO to indicate yes, you do want to set I/O Ports. Each depression of ZERO will alternate between *Aenter* and *Menter*

$\wedge$  Aenter

—When *Aenter* is selected, data is automatically transmitted at the end of each measurement.

—When *Menter* is selected, data is manually transmitted after a measurement by pressing SEND.

5. Press **FUNCTION** to advance to **HDR**. Each depression of **ZERO** will alternate between **HDR ON** and **HDR OFF**.

**HDR ON**

—When *HDR ON* is selected, a header will appear above transmitted or printed data indicating the data type—either **DEN** (density) or **DOT**.

**DEN**  
**C 1.24**

—When *HDR OFF* is selected, no header appears.

**C 1.24**

6. Press **FUNCTION** to advance to **COMP**. Each depression of **ZERO** will alternate between **COMP ON** and **COMP OFF**.

**COMP ON**

—When *COMP ON* is selected, transmitted or printed data will simply be configured with single spaces between each measurement value.

**DEN V0.67 C0.20 M1.23 Y0.77**

—When *COMP OFF* is selected, transmitted or printed data will be configured in a “column” format, with a carriage return and line feed after each measurement value.

**DEN**  
**V0.67**  
**C0.20**  
**M1.23**  
**Y0.77**

7. Press **FUNCTION** three times to exit to normal operation.

## 400 B/W Reflection Densitometer

### RS232 Connector Interface

Your X-Rite 400 instrument can be connected to a computer or printer using a standard RS232 9-pin connector.

For more information on Serial Input Commands and remote control operation of the 400 contact X-Rite Technical Services.

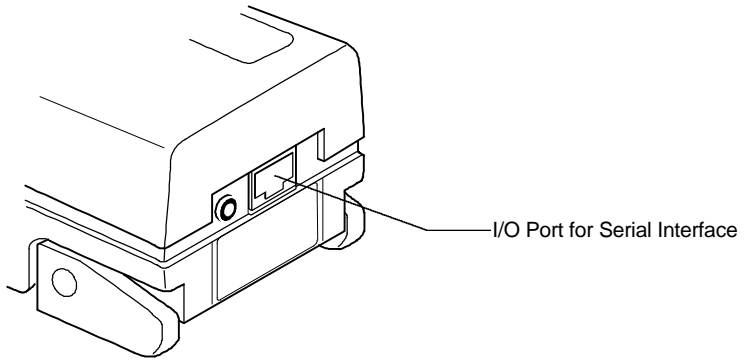

Response Settings.....	2-1
Overview of Calibration	
Procedures .....	2-2
Long Calibration .....	2-3
Quick-Cal™ .....	2-4

### **Frequency of Calibration**

Under long operating conditions, the instrument should be calibrated once per week, or whenever the instrument displays a message regarding calibration. You should perform a “long calibration” whenever possible. However, you can also perform a Quick-Cal™ procedure any time after an initial long calibration has been performed.

Before calibrating, you should determine the appropriate densitometer response setting for your instrument, based on your production control requirements.

### **RESPONSE SETTINGS**

A densitometer’s measurement system consists of several different components (lamp, optics, light sensor). Different densitometers consist of different types of these components. The density readings measured by these systems are called a *densitometer response*. Because components differ among densitometers, standard responses have been established in the industry. These standards ensure that even instruments with different components will measure in accordance with the same response.

### Descriptions of Available Responses

There are two basic versions of the 400, the 400B and the 400R. The 400B allows B-Response. The 400R allows R-Response.

**B –X-Rite “Orthochromatic” Response** This response is blue-green sensitive with insensitivity to red light, making it ideal for use in analyzing color prints for exposure to orthochromatic film. This is also the response generally used for typesetting and B/W printing operations.

**R –X-Rite “Red” Response** This response has a narrow bandwidth with a peak wavelength of approximately 620nm. This response is ideally suited for use with red laser flatbed scanners.

There is separate memory to store calibration for both responses. If you change optics, recalibration must be performed using that response. Once you have calibrated to both responses, you do not have to recalibrate when changing optics.

### OVERVIEW OF CALIBRATION PROCEDURES

Calibrating your instrument is crucial to maintaining its measurement stability. It is also important to maintaining measurement agreement between several densitometers at the same site; and making all densitometers calibrate precisely to the same standard reference. Your 400 instrument allows you to use two different calibrations procedures to address these factors:

1. **Long Calibration** will be used before you take your first measurements for each response. After this calibration procedure has been performed, you can use Quick-Cal™ (see below) to quickly re-calibrate when necessary.
2. **Quick Cal™** allows you to quickly re-calibrate to white without having to re-measure the black.

**LONG CALIBRATION**

1. If this is your first time calibrating, you should plug your instrument in using its AC adapter. This will prevent the microprocessor from going into “sleep” mode to save battery power. With the instrument plugged in, you’ll be free to take your time learning this procedure.
2. Unlock the Shoe.
3. Press the **FUNCTION** and **ENTER** buttons simultaneously until *N cal X Y* appears in the display. *X* stands for the default optic.

N cal X Y
-----------

4. Press **ZERO** to indicate Yes, you do want to calibrate.

N Qcal Y
----------

4. Press **FUNCTION** to select long calibration. **SET LO** appears in the display for a moment.

SET LO
--------

5. Enter the low value of the **WHITE** patch from the reference using the arrow buttons.

To lower the value:

Press and hold the **ZERO** (▼▲) button, then press **FUNCTION** (▼) repeatedly to lower the value until the correct value is shown.

To raise the value:

Press and hold the **ZERO** (▼▲) button, then press **ENTER** (▲) repeatedly to raise the value until the correct value is shown.

---

**TIP:** If you need to move the value up or down by a large amount, hold the (▼▲) button and (▼) or (▲) button down. The numbers will advance faster as you hold it down.

---

8. Release all buttons, then press **ENTER**. **SET HI** is momentarily displayed.
9. Use the arrow buttons to enter the high value of **BLACK** patch from the reference.
10. Press **ENTER** to advance.



16. Read patches on the Reference.
17. Place the instrument target window crosshairs over the alignment marks on the white target patch, then lower the head down onto the shoe. A filter value appears in the display and *READ BLK* (BLACK) appears. Then read the black target patch.
18. The values that appear for each Step measurement should match the values listed on the envelope for that Step. If they do not, repeat the calibration procedure. If discrepancies continue to exist, contact X-Rite Instrument Services.

If all values were correct, your instrument is calibrated!

### **QUICK CAL™**

Once you have performed the long calibration, you can simply perform the Quick Cal™ procedure periodically to set the low density (white) value.

---

**NOTE:** In most cases, you should simply perform an entire long calibration if possible.

---

1. Press **FUNCTION** and **ENTER** simultaneously, then release. *N calX Y* appears in the display. X stands for the default optic; if you have a different response selected, its initial letter will appear in this position. (See “Selecting Response” earlier in this chapter.)
2. Press **ZERO** to indicate yes, you do want to calibrate.
3. Press **ZERO** to select Quick Cal™ procedure.
4. Read Step 1—the white patch—on the reference card.

Your instrument is calibrated!

### **Display Messages**

If any display messages that have not been covered in this chapter appear during any of the calibration procedures, see “Miscellaneous Display Messages” at the end of Chapter 3 for an explanation and instructions.

# 3

## Density Functions

Selecting Density Function .....	3-2
Density Measurement .....	3-2
Density Difference Measurement.....	3-3
Miscellaneous Display	
Messages .....	3-4

Your 400 instrument can be used for density measurement functions, for dot area and dot gain measurement functions, and for calculating measurement range. This chapter covers density functions, and the following chapters cover dot and range functions, respectively.

For density measurement, you need to set some measurement parameters. You need to select:

- the desired measurement *function* (density); and
- the desired density measurement *mode*—absolute density, or density minus reference

These parameters must be set for all types of density measurement. Once these parameters are set, you can set your instrument to evaluate measurement data two different ways:

- As a straight *density measurement* data. Viewing this data requires no additional setup.  
*or*
- As a *density difference measurement* data. This data shows you the amount of difference between the measured density and a pre-set reference density. To view data in this format, you need to establish a reference measurement, and set up the instrument for density difference readings (page 3-3).

## SELECTING DENSITY FUNCTION

1. If this is your first time selecting a measurement function and mode, you should plug your instrument in using its AC adapter. This will prevent the microprocessor from going into “sleep” mode to save battery power. With the instrument plugged in, you’ll be free to take your time learning this procedure.
2. Next, make sure you have the desired response setting selected, and that the instrument is properly calibrated. These procedures are covered in the previous chapter, “Calibration.”
3. To select the measurement method for measuring ink density, press the **FUNCTION** button repeatedly until *DEN* appears in the display. If the density minus reference measurement is necessary, press **ZERO** to turn Reference on. *DEN-R* appears on the screen.

DEN -R
--------

## DENSITY MEASUREMENT

You are now ready to begin taking measurements to check density values on your press sheet gray scale. The type of measurement data that will be displayed will depend on the way you set up your instrument earlier in this chapter. However, for all functions, modes, and methods, the measurement technique is the same. Simply:

1. Center target window over area to be measured.
2. Lower unit to target window and hold closed.
3. Once measurement data is displayed, release the unit.
4. Measurement data will appear either as a normal density value (absolute or minus reference) or difference value.

## DENSITY DIFFERENCE MEASUREMENT

Density difference measurement uses the same parameters as density measurement. To set up for density difference measurement, follow the procedures earlier in this chapter for selecting density function, mode, and color measurement method.

To view measurement data as a density difference value between a measured sample and a known reference—instead of the density value of the measured sample—you must first enter a reference measurement; and then activate the density difference (*DEN-R*) display format.

### Entering a Reference Measurement

1. Press **FUNCTION** until *DEN* appears in the display. After a moment, a value for one a previous measurement appears in the display.
2. Press **ZERO**. *REF* appears for a moment, followed by the current Reference value. If none has been entered, the Reference value is *0.00*.
3. To enter a reference value—or change the current reference value—you can either:
  - measure the reference value directly; or
  - manually enter the reference value using the arrow button functions.

#### To measure the reference value directly:

Measure the color that you wish to use as the reference. Then, press **FUNCTION** to return to normal operation.

#### To enter the reference value manually:

Hold down the **ZERO** (▼▲) button, then press the **FUNCTION** (▼) or **CAL** (▲) button to adjust the value until the desired value is shown. Then, press **FUNCTION** to return to normal operation.

---

**TIP:** If you need to move the value up or down by a large amount, hold the arrow button down. The numbers will advance faster as you hold it down.

---

4. Measure patch that is to be compared. *DEN X* is displayed during measurement, where *X* is the installed optics.

## **MISCELLANEOUS DISPLAY MESSAGES**

During normal operation, some additional display messages may appear. Following are these messages, what these messages mean and what action must be taken when they appear.

*BAT LO* indicates that the batteries are getting low and will soon need to be charged. *BAT LO* only appears while the measurement is in progress. Once *BAT LO* is displayed, you will have approximately 100-200 measurements remaining before charging is required.

*CHARGE* indicates that the batteries are too low to operate the unit and must be recharged. *CHARGE* does not appear until you begin the recharge cycle. Thereafter, the unit will be functional and all previous data will be accessible.

*D TOO HI* indicates density value measured is too high. Make sure you are measuring the right color for the measurement sequence and try again.

*D TOO LO* indicates density value measured is too low. Make sure you are measuring the right color for the measurement sequence and try again.

If *D TOO HIGH* or *D TOO LO* continues to appear, re-calibrate the instrument using long calibration (see Chapter 2).

*INVALID* When the unit is not held down long enough during a measurement, *INVALID* will display.

*LAMP FAIL* Measurement lamp has failed. The lamp should be examined and replaced. When this message occurs, you can get out of this condition (after replacing lamp) by pressing *DEN/DOT* then *COLOR* then *DEN/DOT* or waiting until unit powers down.

*MEM LOST* (Displayed only during power-up) Internal lithium battery is failing. Intermittent connection on Ni-Cad batteries.

*NEED CAL* Calibration has been lost.

*PAPER* Indicates that the next measurement should be paper. If you do not measure paper, *PAPER ? Z* will be displayed during the measurement.

*PAPER ? Z* Displayed during measurement. At this point the 400 is asking if this is a new paper value. If it is a new paper value,

momentarily press **ZERO** before releasing the read head. If no, release the read head and the display will show normal operation.

*SOLID* Indicates that a measurement on a Solid Ink density is necessary. The **SOLID** should be measured first followed by the appropriate **TINT**.

*SOLID? Z* The 400 is asking if the area measured is a Solid. This message appears when measuring a Dot value of 80% or greater, and **ZERO** is depressed. If the area measured is intended to be a Solid, momentarily press **ZERO** before releasing the read head. If not, release the read head and the Dot value is displayed.



Dot Formula .....	4-1
Selecting Dot Area or Dot Gain.	4-4
Dot Area Function.....	4-5
Dot Gain Function.....	4-7

For dot measurements, you need to set some measurement parameters. You need to select:

- The desired formula for dot measurements—the Murray-Davies formula or the Yule-Nielson formula (page 4-1); and
- the desired measurement *function*—dot *area* or dot *gain* (page 4-3);
- NOTE: All dot function measurements are minus paper.

### SELECTING DOT FORMULA

Dot is calculated using either the Murray-Davies formula or the Yule-Nielson formula. The Murray-Davies simply calculates dot by comparing the density of the tint minus paper with the density of the solid minus paper. Your 400 defaults to the Murray-Davies formula for measurements.

The Yule-Nielson formula is similar to Murray-Davies, except that it allows you to compensate for the amount of light that is absorbed or “trapped” when a dot measurement is taken. This is done by first dividing the densities of the paper and the solid by an “n” factor. Using the Murray-Davies equation, your 400 instrument “n” factor is simply 1.00, so the paper and solid densities are not affected. Using Yule-Nielson, the paper and solid densities are multiplied by an “n” factor value that is based on the properties of the substrate material.



## 400 B/W Reflection Densitometer

The Murray-Davies formula for calculating Dot is:

$$\text{Apparent Dot Area} = \frac{1 - 10^{-(D_t)}}{1 - 10^{-(D_s)}} \times 100$$

Where:  $D_t$  = Density of tint minus density of paper

$D_s$  = Density of solid minus density of paper

The Yule-Nielson formula for calculating Dot is:

$$\text{Apparent Dot Area} = \frac{1 - 10^{-(D_t)^n}}{1 - 10^{-(D_s)^n}} \times 100$$

Where:  $D_t$  = Density of tint minus density of paper

$D_s$  = Density of solid minus density of paper

$n$  = “n” Factor

### Selecting Murray-Davies Formula

If you wish to use the Murray-Davies formula, you do not have to make any modifications to the factory-preset mode settings. When Murray Davies is active, dot values are displayed as percentages, with a “%” sign.

If you set your instrument to use Yule Nielson mode by changing the “n” factor, you can return the instrument to Murray Davies mode by setting the “n” factor back to 1.00. Perform the following instructions for selecting Yule-Nielson to reset the “n” factor.

### Selecting Yule-Nielson

When you change the instrument’s “n” factor to a value other than 1.00, measurements are automatically calculated using the Yule-Nielson formula.

To change the “n” factor”:

1. Press the FUNCTION button and the ENTER button simultaneously, then release.

*N cal X Y* appears in the display, where “X” represents Status response you selected (*B* or *R*).

N cal X Y

2. Press FUNCTION to indicate no, you do not want to calibrate. *N mode Y* appears in the display.

N mode Y

- Press ZERO to indicate yes, you do want to set mode.  $\bar{I/O} Y$  appears in the display.

^ I/O Y

- Press FUNCTION three times to advance the mode selection until  $\bar{N}=1.00$  appears.

<N= 1.00

- Here is where you change the “n” factor to prompt Yule-Nielson mode.

Hold down the ZERO (▼▲) button, then press the FUNCTION (▼) or ENTER (▲) button to adjust the value until the desired value is shown.

The following table lists the approximate value you should set as the “n” factor when using Yule-Nielson mode to measure ink on various materials:

<b>Material</b>	<b>“n” Factor</b>
Uncoated Paper	2.7
Coated Paper	1.6-1.7
3M Transfer Key	1.9
DuPont Cromalin	2.6
3M Color Key	4.0
Agfa-Gevaert Gevaproof	1.4
Newsprint	2.5

---

**TIP:** If you need to move the value up or down by a large amount, hold the arrow buttons down. The numbers will advance faster as you hold it down.

---

To return to Murray-Davies mode, use these procedures to re-set the “n” factor value back to 1.00.

- Press FUNCTION to return to normal operation. If you set a value other than 1.00 for the “n” factor, the instrument will use the Yule-Nielson formula to calculate dot.

## SELECTING DOT AREA OR DOT GAIN

1. If this is your first time selecting a measurement function, you should plug your instrument in using its AC adapter. This will prevent the microprocessor from going into “sleep” mode to save battery power. With the instrument plugged in, you’ll be free to take your time learning this procedure.
2. Next, make sure you have the desired response setting selected, and that the instrument is properly calibrated. These procedures are covered in the previous chapter, “Calibration.”
3. To select the measurement method for measuring ink density, press the **FUNCTION** button repeatedly until *DOT AREA* or *DOT GAIN* appears in the display (each time you press the button the display toggles between *DEN* and *DOT AREA* or *DOT GAIN*).

DOT AREA

DOT GAIN

4. If *DOT AREA* appears and you wish to select *DOT GAIN*, press and release the **ZERO** button to toggle the selection. Do the same if *DOT GAIN* appears and you wish to select *DOT AREA*.

**DOT AREA FUNCTION**

Once dot area measurement (*DOT AREA*) mode is selected, *PAPER* appears in the display.

PAPER

1. Center the instrument target window over a sample of the paper, then lower the instrument head to take a reading and hold.

—If the instrument recognizes the measurement as a paper reading, the display flashes *DOT B* (or *DOT R*) momentarily, then becomes ready for the first *SOLID* reading.

—If the instrument does not recognize the measurement as a paper reading, *PAPER? Z* appears.

PAPER? Z

Keep the instrument pressed down, then press **ZERO** to indicate that yes, this is the new paper value. Then, the display becomes ready for the first *SOLID* reading.

SOLID

2. Measure the solid patch. *DOT* is displayed during measurement, then the measurement data appears.

DOT

1.57s

If Solid is displayed as a Dot value (a percentage, such as 94%) instead of a solid density value (such as 1.57s), hold the instrument closed and press **ZERO**.

If *SOLID? Z* is displayed, press **ZERO** to measure as a Solid, then release the instrument.

---

**NOTE:** Solid density is displayed minus paper.

---

## 400 B/W Reflection Densitometer

3. Read a tint of the solid color you just measured. During measurement, *DOT* is displayed. Then, the Dot value is displayed.



4. Measure additional tints of that color. The instrument automatically recognizes the measurements as tint values and displays the tint percentage.
5. When you are ready to measure another color, simply measure the solid and repeat the procedures beginning with #2. The instrument automatically recognizes the measurement as a solid. Also, you do not need to enter a new paper measurement.

### Display Messages

If any display messages that have not been covered in this chapter appear during any of the dot gain functions, see “Miscellaneous Display Messages” at the end of Chapter 3 for an explanation and instructions.

## DOT GAIN FUNCTION

Dot gain measurement compares the tint percentage of a color patch on paper to the intended tint percentage produced on the film.

Your first dot gain measurement compares the dot percentage of the measured patch to the first reference value (r1). The difference between the reference value and the measured value is calculated as dot gain—the amount the ink dots have spread on the paper.

If needed, you can adjust the Reference values to meet your specific needs. These procedures are covered next. If you wish to simply use the factory preset reference values, you can skip ahead to “Dot Gain Measurement.”

### Adjusting Dot Gain Reference Values

Once dot gain measurement (*DOT GAIN*) mode is selected, *PAPER* appears in the display.

PAPER

1. Press ZERO. *REF* appears in the display momentarily, followed by one of the reference values—either r1, r2, or r3.

< 75 {

2. When the color and reference value you wish to change appear in the display, use ZERO (▼▲), ENTER (▲), and FUNCTION (▼) buttons to adjust the value.

—Press and hold ZERO, then press ENTER (▲) to raise the value;

—Press and hold ZERO, then press FUNCTION (▼) to lower the value.

When you change the preset values, they are turned “off.” Your new reference values can be set within the following ranges.

—r1 can be set between 1% and 45%.

—r2 can be set between 46% and 64%

—r3 can be set between 65% and 100%

These value ranges apply to both optics.

3. Advance to the next reference value, then repeat #2; or press ZERO to advance to the next reference value, either r1, r2, or r3.

## 400 B/W Reflection Densitometer

4. Repeat #2 and #3 until all reference values are set to your preferences.
5. Press **FUNCTION** to return to dot gain measurement mode. Measurements at each tint will be compared to the appropriate reference value.

### Dot Gain Measurement

Once dot gain measurement (*DOT GAIN*) mode is selected, *PAPER* appears in the display.

**PAPER**

1. Center the instrument target window over a sample of the paper, then lower the instrument head to take a reading and hold.

—If the instrument recognizes the measurement as a paper reading, the display flashes *DOT B* (or *DOT R*) momentarily, the paper value is displayed, then becomes ready for the first *SOLID* reading.

—If the instrument does not recognize the measurement as a paper reading, *PAPER? Z* appears.

**PAPER? Z**

Keep the instrument pressed down, then press **ZERO** to indicate that yes, this is the new paper value. Then, the display becomes ready for the first *SOLID* reading.

**SOLID**

2. Measure the solid patch. *DOT* is displayed during measurement, then the measurement data appears.

If Solid is displayed as a Dot value (a percentage, such as 94%) instead of a solid density value (such as 1.57s), hold the instrument closed and press **ZERO**.

**DOT**

**1.57s**

If *SOLID? Z* is displayed, press **ZERO** to measure as a Solid, then release the instrument.

---

**NOTE:** Solid density is displayed minus paper.

---

3. Read the first tint of the solid color you just measured. This should be the color patch with the lowest tint percentage, such as the 25% patch. During measurement, *DOT X* is displayed. Then, the Dot Gain value is displayed.

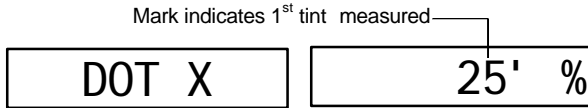

A mark before the percentage symbol indicates which tint percentage in the sequence has been measured.

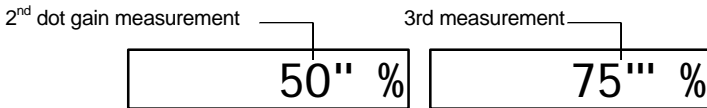

4. Measure the remaining tints of that color. The instrument automatically recognizes the measurements as tint values and displays the dot gain value for that tint. Display marks indicate which tint percentage in the sequence has been measured.

### **Display Messages**

If any display messages that have not been covered in this chapter appear during any of the dot gain functions, see “Miscellaneous Display Messages” at the end of Chapter 3 for an explanation and instructions.





Reference Value .....	5-1
Absolute Range Measurement..	5-2
Range Minus Reference Measurement .....	5-2

The Range function subtracts the lowest measurement from the highest and displays the difference.

$$\text{Range} = D_{\max} - D_{\min}$$

where  $D_{\max}$  = Maximum (highest) density

and  $D_{\min}$  = Minimum (lowest) density

The Range function can have a reference value (if selected) subtracted from the measurement, giving you a difference value.

Before the Range can be calculated, a reference value needs to be selected. You can display a previous value or enter a new step reference. Absolute Range takes a true reading of the sample—including the paper or reference. Range Minus Reference takes into account the effect of the paper or reference and calculates only the ink density.

## DISPLAY/ENTER A REFERENCE VALUE

There are two ways to *display* the reference value: at menu level or when data is displayed after entering a –REF function. To *enter* a reference value, a Step Reference must be performed.

### To display the reference value:

- At menu level (e.g. when *RANGE –R* is displayed) hold ZERO depressed until the reference value appears.
- Once the reference value is displayed, Reference can be entered by numerically entering the reference value using the ZERO

## 400 B/W Reflection Densitometer

key in conjunction with FUNCTION (to decrease the value) or ENTER (to increase). After entering the reference value, or if you want to exit the reference function at anytime, momentarily press FUNCTION and the display will return to normal operation.

### To enter a reference value:

- Press FUNCTION to select *RANGE -R*. If *RANGE* appears, press ZERO to turn Reference on. *READ NEW* is displayed. With unit up, depress and hold ZERO until *REF* is momentarily displayed. The reference is then displayed. A new reference can be entered by using the arrow keys. After reference entry, press FUNCTION to return to normal operation.

## ABSOLUTE RANGE MEASUREMENT

1. Press FUNCTION to select RANGE. If RANGE -R appears, press ZERO to turn Reference off. READ NEW is displayed.
2. Measure the patch. RANGE X is displayed while measuring, where X is the installed optics. When the read head is down, current density value is displayed. In addition, a  $\wedge$ ,  $\vee$ , or D is displayed to indicate Dmax, Dmin, or a density within range, respectively.
3. When the read head is released the range is displayed.

---

**NOTE:** Momentary depressions of the ZERO key pages through the minimum value, maximum value, READ NEW, and the range value.

---

**RANGE MINUS REFERENCE MEASUREMENT**

1. Press Function to select RANGE -R. If RANGE appears, press ZERO to turn Reference on. READ NEW is displayed.
2. Measure Patch. RANGE X is displayed while measuring, where X is the installed optics. When the read head is down, current density value is displayed. In addition, a  $\wedge$ ,  $\vee$ , or D is displayed to indicate Dmax, Dmin, or a density within range, respectively.
3. When the read head is released, the range value minus the reference is displayed.

---

NOTE: Momentary depressions of the ZERO key will page through the minimum value, maximum value, READ NEW, and the range value.

---



- Serial Interface Information ..... 6-1
- Instrument Specifications..... 6-4
- Accessories ..... 6-6
- General Cleaning..... 6-7
- Optics Maintenance ..... 6-7
- Target Window Replacement.... 6-8
- Lamp Replacement ..... 6-9

## SERIAL INTERFACE INFORMATION

The connector used for serial input/output is a Modular 10 circuit type. Figure 5-1 is the connection diagram.

**Figure 5-1**

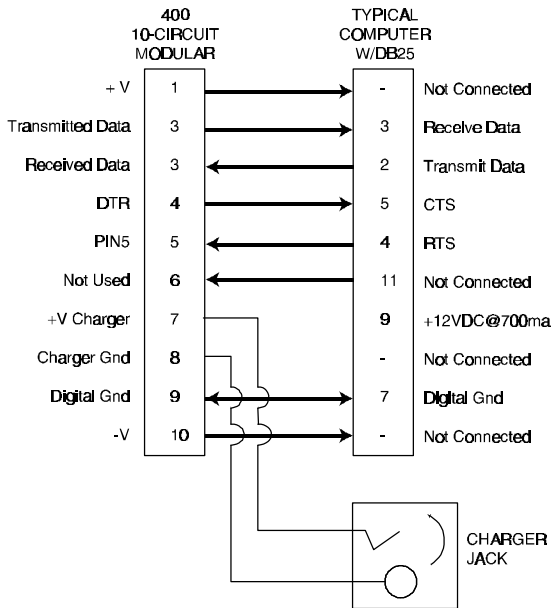

Arrows indicate signal direction

## 400 B/W Reflection Densitometer

An RS232 to modular interface adapter is available from X-Rite which performs as shown in the diagram on the previous page. This adapter also provides a jack for the AC adapter so that only one cable need be connected to the 400. Also, when the adapter is not connected to the jack, the +V CHARGER is connected to pin 9 of the DB25 in the diagram. The charger ground is connected to the jack ground only.

The part numbers for these interface adapters are: P/N 418-70 (male DB25 connector) P/N 418-71 (female DB25 connector) See "Accessories" later in this chapter for other adapters.

A 10-foot modular to modular cable for connection of the 400 to the interface adapter is available by ordering P/N SE108-69.

### Term Definitions

**Pin 2 Transmitted Data:** Data transmitted from the densitometer with parameters (baud rate, format) set by the densitometer.

**Pin 3 Received Data:** Data received by the densitometer from outside source using the same parameters as the densitometer.

**Pin 4 DTR (Data Terminal Ready):** Logic 0 active (On Line) and Logic 1 during: Power Off, Power Up, Self Test, during measurements, and when serving RCI.

**Pin 5** is ignored.

**Pin 7:** This pin is used for supplying 12VDC @ 700ma for charging the 400 without having the Adapter connected directly to the unit.

### Input Characteristics

Logic 1=+.8VDC to -25VDC

Logic 0=+2.25VDC to +25VDC

### Output Characteristics

Logic 1=approximately -4VDC

Logic 0 = approximately +5VDC

Outputs are @ 0VDC during Power Down.

A typical interconnection between the 400 and a computer—in its simplest form—is shown in Figure 5-2.

**Figure 5-2**

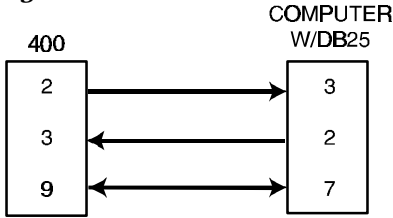

### **Serial Output**

The data format that is transmitted from the 400 is determined by the I/O PORT options found in Chapter 1 under “I/O Port Setup.”

Data transmitted by the 400 shall have one start bit (Logic 0), 7 bits of ASCII, one parity bit (set to Logic 0), and then one stop bit (Logic 1).

### **Serial Input Commands**

Your 400 is equipped with an input that allows the 400 to be controlled or monitored remotely. Every function that can be performed by the 400 (plus a few special functions not activated by the keyboard) can be activated via the serial input. This Remote Control Interface is covered by U.S. Patent 4,591,978.

For more information on Serial Input Commands and remote control operation of the 400, contact X-Rite Customer Services at 1-888-826-3059.



**INSTRUMENT SPECIFICATIONS**

**Display**

Dot Matrix LCD

**Measuring Geometry**

ANSI PH 2.17/DIN 16536 multi-sensor array

**Light Source**

Filament bulb 3000°K DIN approx. 2856°K ANSI

**Receiver**

Silicon Photodiode

**Color Response**

B optics with X-Rite Orthochromatic Response.

R optics with X-Rite Red (Laser) Response.

**Measuring Range**

0.00D-2.5D for B & R

0.00D-2.20D for BS & RS

0-100% dot

**Reproducibility**

$\pm 0.01D$

$\pm 1\%$  for dot area (10-100%)

**Linearity**

$\pm 0.01D$  or  $\pm 1\%$

**Inter-Instrument Agreement**

$\pm 0.02D$  or  $\pm 2\%$

**Aperture Diameter**

400B,R—3.4mm

400BS,RS—1.7mm

**Calibration**

Automatic with Quick Cal™

Adjusts Zero and Slope for Density

**Warm Up Time**

None

**Zero Stability**

±.01D maximum per 8 hours

**Slope Stability**

±1% maximum per year

**Power Supply**

Six rechargeable AA NI-CAD batteries 7.2v total rated @600m Ah (included)

**Charge Time**

Approximately 14 hours

**AC Adapter Requirements**

400 90-130VAC, 50-60Hz, 15W Maximum

400X 180-260VAC, 50-60Hz, 15W Maximum

**Operating Temperature Range**

50°-104°F /10°-40°C

**Measurements Per Charge**

Approx. 4500 (usage dependent)

**Measuring Time**

Approximately 0.5 seconds

**Weight**

800 grams

**Dimensions**

7.4cm H x 8.cm W x 19.6cm L

**ACCESSORIES**

**Accessories Included**

- Reflection Reference
- Operation Manual
- AC Adapter
- Carrying Case

Specifications and design subject to change without notice.

**Accessories and Replacement Parts Available**

- Security Cable ..... P/N 418-75
- 1.7mm Target Window ..... P/N 418-21-017-KIT
- 3.4mm Target Window ..... P/N 418-21-034-KIT
- 1.7mm Aperture ..... P/N 418-63-017
- 3.4mm Aperture ..... P/N 418-63-034
- Lamp Assembly ..... P/N 418-13
- B Optics ..... P/N 400B-35
- BS Optics ..... P/N 400BS-35
- R Optics ..... P/N 400R-35
- RS Optics ..... P/N 400RS-35
- Modular Interconnect Cable..... P/N SE108-69
- DB25P DCE (Null Modem) Interface Adapter ..... P/N 418-70
- DB25S DCE (Null Modem) Interface Adapter ..... P/N 418-71
- DB25P DTE (Normal) Interface Adapter ..... P/N 418-80
- DB25S DTE (Normal) Interface Adapter ..... P/N 418-81
- DB9P Interface Adapter..... P/N 418-90
- DB9S Interface Adapter..... P/N 418-91
- Modular Interconnect Cable for Macintosh® computers  
with 8 pin mini-DIN connector..... P/N 418-79

For further information on accessories contact your X-Rite representative or call X-Rite, Inc. at: 1-888-826-3059.

## GENERAL CLEANING

The exterior of the instrument can be wiped clean with a cloth dampened in water or a mild cleaner whenever required.

---

**NOTE:** Do not use any solvents to remove ink from the cover.

---

## OPTICS MAINTENANCE

1. Remove Optics assembly by removing sensor nose screws from densitometer housing, and then lifting the assembly upward. (Figure 5-3)

**Figure 5-3**

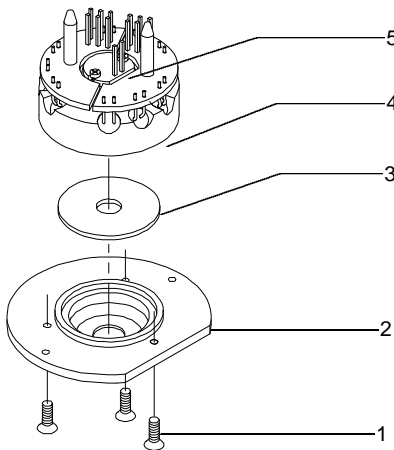

2. Remove three inner screws [1] on sensor nose [2] and rotate Optics over carefully so sensor nose [2] is at bottom.
3. Carefully lift up Optics assembly [4] separating from sensor nose [2].
4. Clean Optics sensors with camelhair brush and set aside.
5. Carefully remove IR Glass [3] and optional polarizing filter (if installed) from sensor nose [2].
6. Remove dust and lint from inner sensor nose and filter(s) with camelhair brush.

## 400 B/W Reflection Densitometer

7. Carefully reinstall optional polarizing filter (if used) and IR Glass [3] (holding both by edges) into sensor nose, making sure filter(s) are properly seated.
8. Align flat edge of sensor nose [2] with flat edge on Lamp assembly P.C.B [5] and secure sensor nose [2] to Optics assembly [4] with three inner screws [1].
9. Carefully reinstall Optics assembly into densitometer by facing flat edge of sensor nose to front of densitometer. Work into position until alignment pins and connector pins are properly seated.
10. Insert and tighten sensor nose screws.

### TARGET WINDOW REPLACEMENT

1. Remove old target window by pushing downward on top of shoe [1]. Clean off any remaining adhesive from shoe. (Figure 5-4)

Figure 5-4

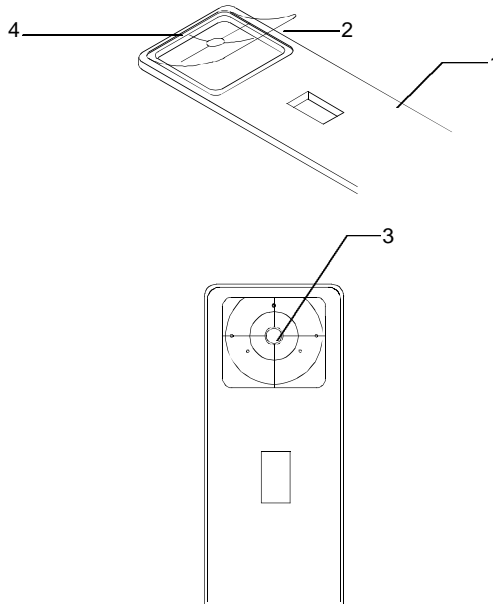

2. Turn densitometer over and compress shoe [1] all the way down, and lock shoe.
3. Remove paper backing from tape strip on new target window [2].

4. Place one taped edge of target window [2] on indent [4] at bottom of shoe [1].
5. Align hole of target window [2] exactly in center of hole in sensor nose [3] and press remaining three sides of target window into place.
6. Unlock shoe.

## **LAMP REPLACEMENT**

### **Lamp Removal**

1. Remove Optics assembly by removing sensor nose screws [1] from the densitometer housing, and then lifting assembly upward. **THE THREE INNER SCREWS ON SENSOR NOSE ARE NOT TO BE REMOVED.** (Figure 5-5)

**Figure 5-5**

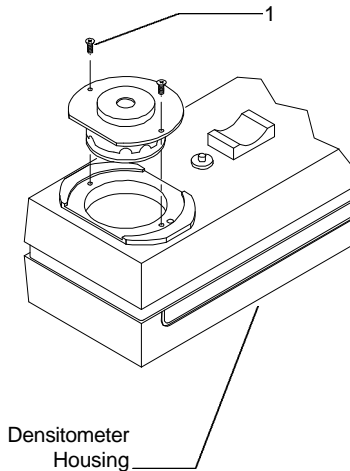

2. Once Optics assembly is free, rotate over and remove two screws [4] from the lamp PCB [3]. (Figure 5-6)

**Figure 5-6**

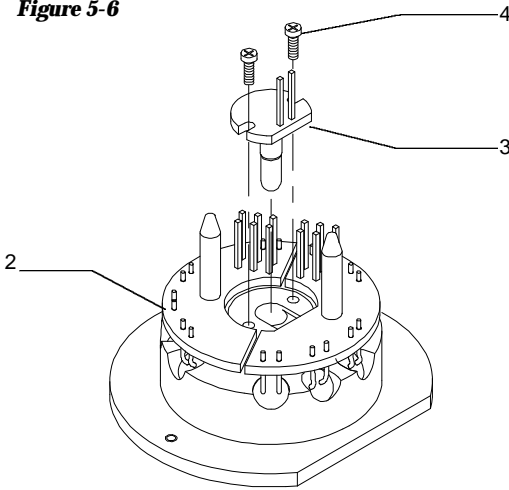

3. Carefully remove old Lamp assembly [3] by lifting upward and discarding.

### **Lamp Installation**

1. Align the flat edges of Optics PCB [2] and new Lamp PCB [3], and insert into Optics assembly. (figure 5-6)

---

**NOTE: EXTREME CAUTION MUST BE TAKEN WHEN INSTALLING NEW LAMP. DO NOT BEND LAMP LEADS.**

---

2. Insert and tighten the two lamp screws [4].
3. Carefully reinstall Optics assembly into densitometer by facing flat edge of sensor nose to front of densitometer. Work into position until alignment pins and connector pins are properly seated.
4. Insert and tighten sensor nose screws [1]. (Figure 5-5)

Proprietary Notice.....	7-1
Limited Warranty .....	7-2
Index .....	7-3

**PROPRIETARY NOTICE**

The information contained in this manual is derived from patent and proprietary data from X-Rite, Incorporated. This manual has been prepared solely for the purpose of assisting operation and maintenance personnel in their use and general maintenance of the X-Rite 400.

The contents of this manual are the property of X-Rite, Incorporated and are copyrighted. Any reproduction in whole or part is strictly prohibited. Publication of this information does not imply any rights to reproduce or use it for purposes other than installing, operating, or maintaining the equipment described herein.

This instrument is covered by one or more of the following U.S. patents: #4,080,075; #4,591,978; #5,015,098; and patents pending. Foreign patent numbers provided on request.



**LIMITED WARRANTY**

X-Rite, Incorporated warrants each instrument manufactured by them to be free of defects in material and workmanship for a period of 12 months. THERE ARE NO WARRANTIES OF MERCHANTABILITY OR FITNESS. THIS WARRANTY OBLIGATION IS LIMITED TO SERVICING THE UNIT RETURNED TO THE FACTORY FOR THAT PURPOSE AND EXCLUDES THE LAMP AND NI-CAD BATTERIES.

The instrument shall be returned with transportation charges prepaid. If the fault has been caused by misuse or abnormal operating conditions, repairs will be billed at a nominal cost. In this case, an estimate will be submitted before work is started, if requested.

A Warranty Registration Card is enclosed with each instrument. The purchaser should fill in the card completely and return it to X-Rite, Incorporated postmarked no later than ten (10) days from the date of receipt. This card registers your system with us for warranty coverage. Once your unit is registered, we are able to maintain a file to help expedite service in case it is needed.

Always include serial number and place of purchase in any correspondence concerning your instrument. The serial number is located at the rear of the instrument.

X-Rite, Incorporated offers a repair program for instruments out of warranty. For more information, contact X-Rite Technical Services Department.

This agreement shall be interpreted in accordance with the laws of the State of Michigan and jurisdiction and venue shall lie with the courts of Michigan as selected by X-Rite, Incorporated.

# Index

- Absolute Range Measurement, 5-2
- Accessories, 6-6
- Adjusting the display angle, 1-9
- Batteries and Power, 1-6, 1-7
- Calibration, 2-2
  - Long Calibration, 2-3
  - Quick Cal, 2-4
- Charging the battery, 1-6
- Cleaning, 6-7
- Density functions, 3-1, 3-2
  - Density difference measurement, 3-3
  - Density measurement, 3-2
- Display messages, 3-4
- Dot functions, 4-1, 4-4
  - Dot area function, 4-5
  - Dot gain function, 4-7
- Features, 1-1
- I/O port setup, 1-10
- Instrument Vocabulary drawings, 1-4
- Maintenance, 6-7
- Murray-Davies formula, 4-2
- Packaging and Parts, 1-3
- PAPER, 3-4
- Powering the Instrument, 1-6
- Quick Cal™, 2-4
- Range Minus Reference Measurement, 5-2
- Reference / Paper value, 5-1, 5-2
- Response settings, 2-1
- Responses, 2-2
- Return Packaging, 1-3
- RS232 connector interface, 1-12
- Selecting response, 2-14
- Serial interface information, 6-1
- Specifications, 6-4
- Unlocking/Locking the Shoe, 1-5
- Yule-Nielson formula, 4-2





**X-Rite, Incorporated—World Headquarters**

3100 44th Street S.W. • Grandville, Michigan 49418 • USA

www.x-rite.com • (616) 534-7663

Toll-Free U.S. Numbers

Tel: 1-888-826-3059 • Fax: 1-888-826-3061

Toll-Free International Numbers

Tel: 1-888-826-3039 • Fax: 1-888-826-3041

**X-Rite GmbH**

Stollwerckstraße 32 • 51149 Köln • Germany

Tel: (49) 2203-91450 • Fax: (49) 2203-914519

**X-Rite GmbH**

Sochorova 705 • CZ-682 • 11 Vyskov • Czech Republic

Tel: (420) 507-328197 • Fax: (420) 507-328138

**X-Rite Asia Pacific Ltd.**

Room 808-10 • Kornhill Metro Tower • 1 Kornhill Road • Quarry Bay

Hong Kong • Tel: (852) 2-568-6283 • Fax: (852) 2-885-8610

**X-Rite Ltd.**

The Acumen Centre • First Avenue

Poynton, Cheshire • England

Tel: 44-0-1625-871100 • Fax: 44-0-1625-871444

**X-Rite Méditerranée**

Parc du Moulin de Massy • 35, rue du Saule Trapu • 91300 Massy • France

Tel: 33-1-69.53.66.20 • Fax: 33-1-69.53.00.52

**X-Rite Asia Pacific Ltd. - Japan Office**

Suite 506 AIOS Gotanda • 1-7-11 Higashi-Gotanda

Shinagawa-ku, Tokyo • 141-0022 Japan

Tel: 81-3-5447-1607 • Fax: 81-3-5447-1608