

XAC

A Partner You Can Trust

CLOUD POS PAYMENT DEVICE

xCL_E200CP **SERIES**

INSTALLATION GUIDE

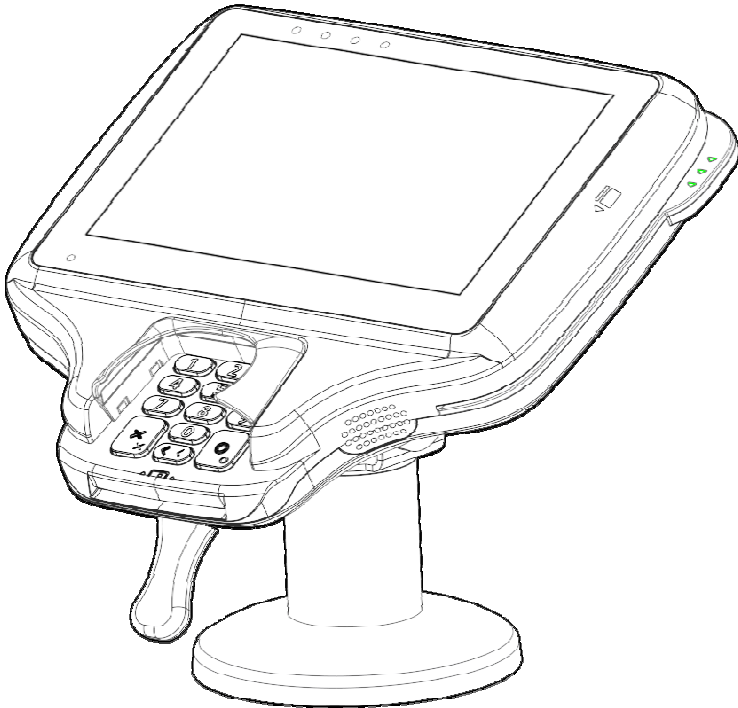

1. DEVICE OVERVIEW

Key Buttons & Interface Ports (Figure 1):

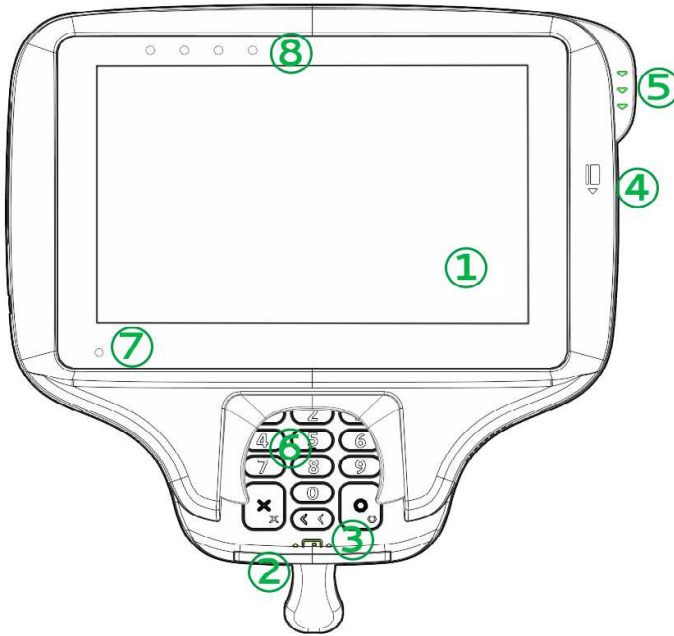

Figure 1

FRONT SIDE	1	Touch Panel
	2	Smart Card Reader (SCR) slot
	3	Smart Card Reader LED indicator
	4	Magnetic Strip Reader (MSR) slot
	5	Magnetic Strip Reader (MSR) LED indicator
	6	13 keys Rubber PINPAD
	7	Camera
	8	Contactless LED indicator

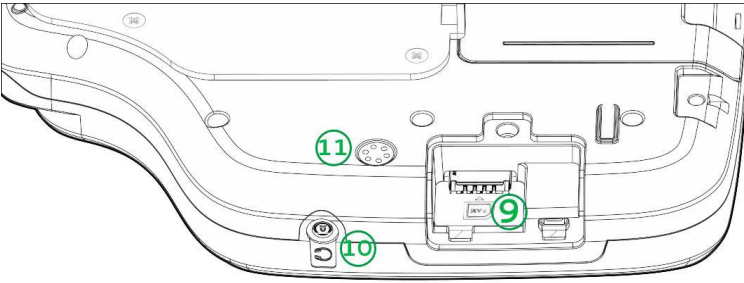

Figure 2

LEFT SIDE	9	SAM Card Slot
	10	Audio Jack
	11	Buzzer

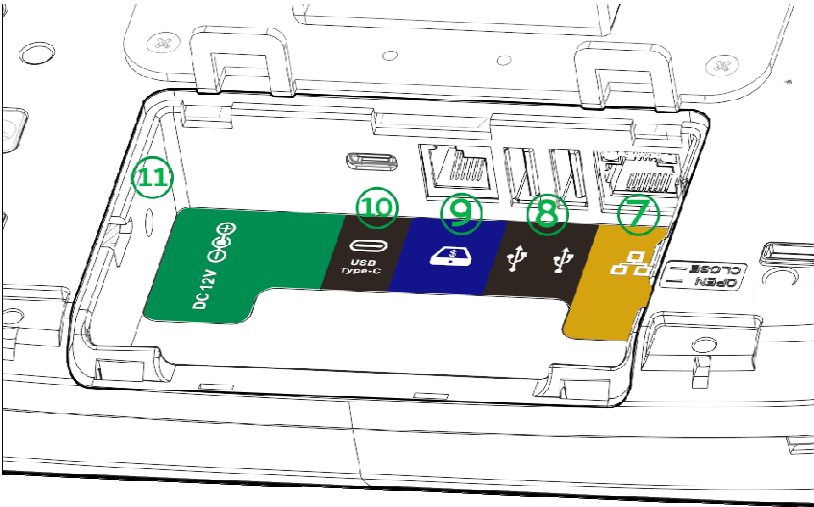

Figure 3

REAR SIDE	7	Ethernet Port
	8	USB Host Port
	9	Cash Draw Port
	10	USB Type C Device Port
	11	12V DC Power Jack

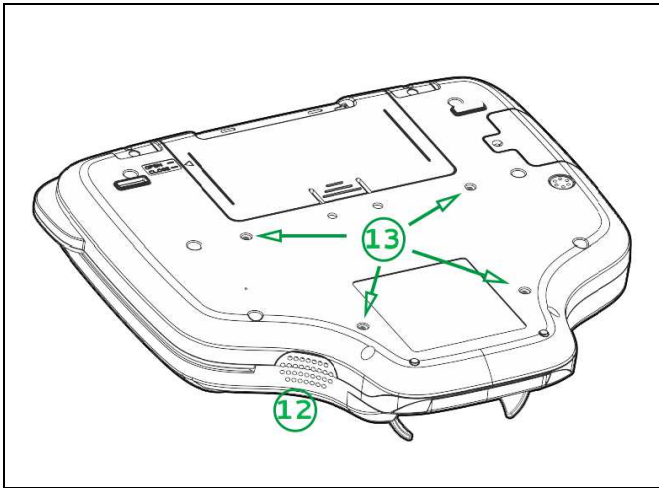

Figure 4

REAR SIDE	12	Speaker
	13	Stand Mounting Holes

■ **Power Adapter spec:**

Input: 100 ~240 AC

Output: 12V DC

(Use only the AC adapter approved and provided by XAC Automation Corporation for use with this device. Use of any other AC adapter may cause a risk of fire or explosion)

■ **Operating Temperature:** 0°C to 40°C

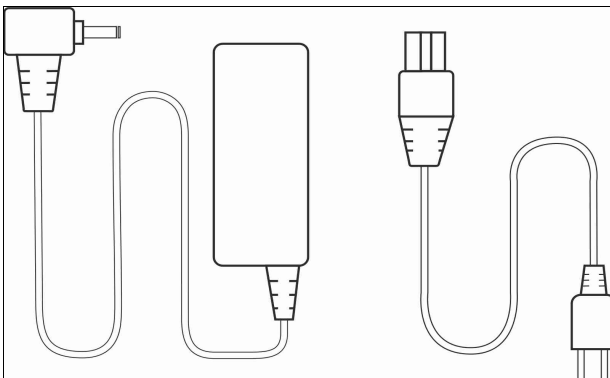

2. USING THE MAGNETIC CARD READER

Swipe the card through the slot with magnetic stripe side facing the same direction as the display.

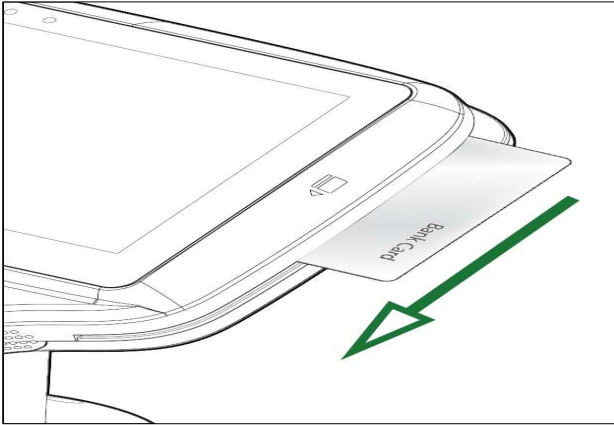

Figure 5

3. USING THE IC CARD READER

Insert an IC card into the slot (Figure 6) with the chip side facing the same direction as the touch panel

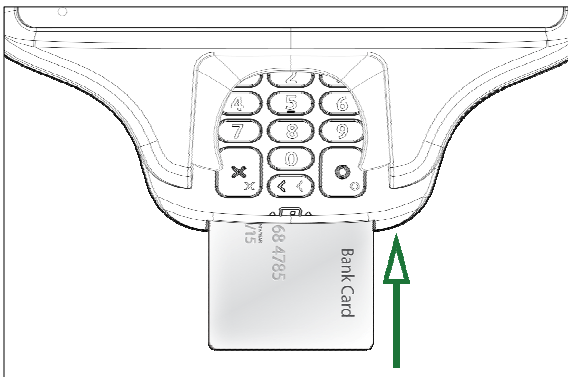

Figure 6

4. USING THE CONTACTLESS CARD READER

Tap the contactless card on top of the contactless logo



Figure 7

5. HOW TO INSERT SAM

Insert an SAM card into the slot (**Figure 8**) with the chip side facing

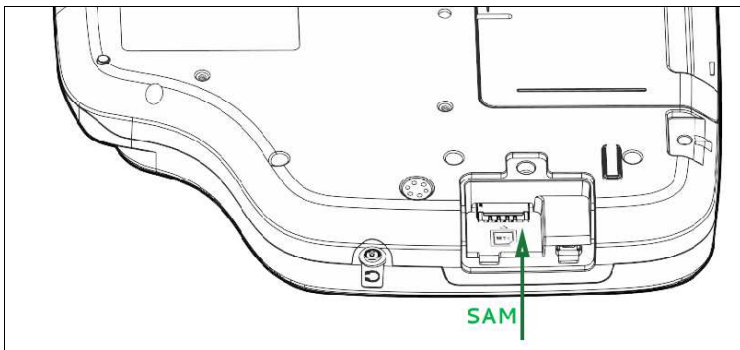

Figure 8

6. HOW TO OPEN SAM COVER

Take the screw out (1) and then pull out the SAM cover (2)

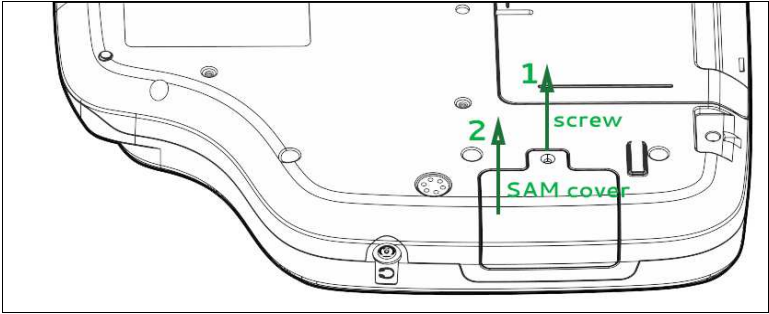

Figure 9

7. HOW TO OPEN IO COVER

Push the IO TOP cover (1) and then pull out the IO cover (2)

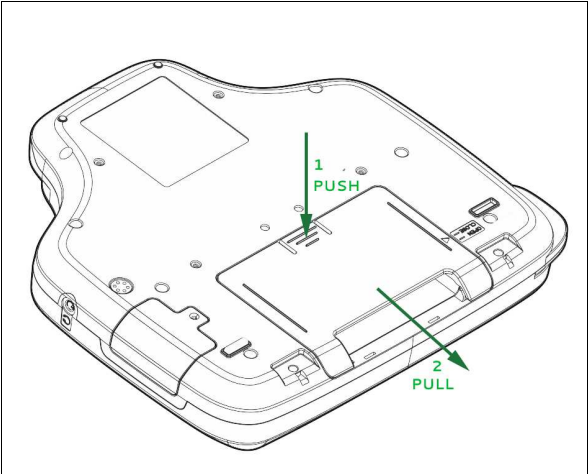

Figure 10

CAUTION:

RISK OF EXPLOSION IF BATTERY IS REPLACED BY AN INCORRECT TYPE. DISPOSE OF USED BATTERIES ACCORDING TO THE INSTRUCTIONS.

The IO & SAM covers provide for SAM card and I/O port installation Removal Warning:

When removing the screw of SAM cover and the IO,SAM covers for the purposes of SAM card and I/O port installation, remember to put back the cover and the screw before power on the POS.

FEDERAL COMMUNICATION COMMISSION INTERFERENCE STATEMENT

This device complies with Part 15 of the FCC Rules. Operation is subject to the following two conditions: (1) This device may not cause harmful interference, and (2) this device must accept any interference received, including interference that may cause undesired operation.

Note: This equipment has been tested and found to comply with the limits for a Class A digital device, pursuant to part 15 of the FCC Rules. These limits are designed to provide reasonable protection against harmful interference when the equipment is operated in a commercial environment. This equipment generates, uses, and can radiate radio frequency energy and, if not installed and used in accordance with the instruction manual, may cause harmful interference to radio communications. Operation of this equipment in a residential area is likely to cause harmful interference in which case the user will be required to correct the interference at his owns expense.

FCC Caution: Any changes or modifications not expressly approved by the party responsible for compliance could void the user's authority to operate this equipment.

This transmitter must not be co-located or operating in conjunction with any other antenna or transmitter.

Radiation Exposure Statement:

This equipment complies with FCC radiation exposure limits set forth for an uncontrolled environment. This equipment should be installed and operated with minimum distance 20cm between the radiator & your body.



XAC Automation Corporation
886-3-577-2738

The above information is the exclusive intellectual property of XAC Automation Corporation and shall not be disclosed, distributed or reproduced without permission of XAC Automation Corporation.