

Document Centre
490/480/470/460 ST
System Administration Guide

August 2001

604P06900

Xerox Document Centre Model _____

Serial Number _____

Xerox
Bessemer Road
Welwyn Garden City
Hertfordshire AL71HE
Great Britain

©2001 by Xerox Corporation. All rights reserved.

Copyright protection claimed includes all forms and matters of copyrighted material and information now allowed by statutory or judicial law or hereinafter granted, including without limitation material generated from the software programmes that are displayed on the screen such as icons, screen display looks, etc.

XEROX®, The Document Company® and the stylised X and identifying product names and numbers are registered trademarks of XEROX CORPORATION or Xerox (Europe) limited.

The Document Centre ST model includes an implementation of LZW licensed under U.S. Patent 4,558,302.

Product names used in this guide may be trademarks or registered trademarks of their respective companies and are hereby acknowledged.

This document contains images of screens that were created using Zinc Application Framework software version 3.5 © January 1997 Zinc Software Inc.



As an ENERGY STAR® partner, Xerox Corporation has determined that this product meets the ENERGY STAR® guidelines for energy efficiency.



RAL, the German Institute for Quality Assurance and Labeling, has awarded the Document Centre 255 and 265 DC the Blue Angel Environmental Label, distinguishing it as a machine which satisfies Blue Angel criteria for environmental acceptability in terms of machine design, manufacture, and operation.

Whilst the information in this Guide is correct at the time of first publication, Xerox reserves the right at any time to change the information without notice. Changes are made periodically to this document. Changes and technical updates will be added in subsequent editions.

The Document Centre ST model includes software provided by the Internet Software Consortium.

Copyright (c) 1995, 1996, 1997, 1998, 1999, 2000, 2001

The Internet Software Consortium - DHCP. All rights reserved.

Redistribution and use in source and binary forms, with or without modification, are permitted provided that the following conditions are met:

Redistributions of source code must retain the above copyright notice, this list of conditions and the following disclaimer.

Redistributions in binary form must reproduce the above copyright notice, this list of conditions and the following disclaimer in the documentation and/or other materials provided with the distribution.

Neither the name of The Internet Software Consortium - DHCP nor the names of its contributors may be used to endorse or promote products derived from this software without specific prior written permission.

This Software Is Provided By The Internet Software Consortium And Contributors "As Is" And Any Express Or Implied Warranties, Including, But Not Limited To, The Implied Warranties Of Merchantability And Fitness For A Particular Purpose Are Disclaimed. In No Event Shall The Internet Software Consortium Or Contributors Be Liable For Any Direct, Indirect, Incidental, Special, Exemplary, Or Consequential Damages (Including, But Not Limited To, Procurement Of Substitute Goods Or Services; Loss Of Use, Data, Or Profits; Or Business Interruption) However Caused And On Any Theory Of Liability, Whether In Contract, Strict Liability, Or Tort (Including Negligence Or Otherwise) Arising In Any Way Out Of The Use Of This Software, Even If Advised Of The Possibility Of Such Damage.



Approvals and Certifications

The CE marking applied to this product symbolises XEROX Limited Declaration of Conformity with the following applicable Directives of the European Union as of the dates indicated:

January 1, 1995:

Council Directive 73/23/EEC amended by Council Directive 93/68/EEC, approximation of the laws of the member states related to low voltage equipment.

January 1, 1996:

Council Directive 89/336/EEC, approximation of the laws of the member states related to electromagnetic compatibility.

March 9, 1999:

Council Directive 99/5/EC, on radio equipment and telecommunications terminal equipment and the mutual recognition of their conformity.

A full declaration, defining the relevant directives and referenced standards can be obtained from your XEROX Limited representative or by contacting:

Environment, Health and Safety,
XEROX Limited,
PO Box 17,
Bessemer Road,
Welwyn Garden City,
Hertfordshire
AL7 1HE
ENGLAND.
Tel Number +44 (0) 1707 353434

WARNING

This product is certified manufactured and tested in compliance with strict safety and radio frequency interference regulations. Any unauthorised alteration which, includes the addition of new functions or the connection of external devices, may impact this certification. Please contact your local XEROX Limited representative for a list of approved accessories.

WARNING

In order to allow this equipment to operate in proximity to Industrial, Scientific and Medical (ISM) equipment, the external radiation from the ISM equipment may have to be limited or special mitigation measures taken.

WARNING

Shielded cables must be used with this equipment to maintain compliance with Council Directive 89/336/EEC.

The Electricity at Work Regulation (in England and Wales) UK ONLY

Electricity at Work Regulations:

The Electricity at Work Regulation 1989 came into force in England and Wales on the 1 April 1990. This 1989 Regulation places a duty on all employers and self-employed persons to ensure the electrical system in their premises are constructed, maintained and operated in such a manner as to prevent, so far as reasonably practical, danger. This includes ensuring all electrical equipment connected to such electrical systems are safely constructed, maintained and operated.

All Xerox equipment have been designed to exacting safety standards. They have all undergone a variety of stringent safety tests including earth bond, insulation resistance and electrical strength tests. Xerox manufacturing plants have been awarded ISO 9000 quality certification and are subject to regular audits by the British Standards Institution or equivalent national standards body.

Xerox equipment which has been properly and regularly serviced and maintained should not have to undergo additional specific safety tests pursuant to the 1989 Regulation. Customers wishing to complete safety testing should contact Xerox (see page 1) for advice prior to any test implementation.

Xerox equipment should, however, be properly and regularly serviced and maintained at all times.

QUESTION: What is the Electricity at Work Regulation?

ANSWER: The Electricity at Work Regulation 1989 came into force in England and Wales on the 1 April 1990. This 1989 Regulation places a duty on all employers and self-employed persons to ensure the electrical systems in their premises are constructed, maintained and operated in such a manner as to prevent, so far as reasonably practicable, danger. This includes ensuring all electrical products connected to such electrical systems are safely constructed, maintained and operated.

QUESTION: Does Xerox comply with the Electricity at Work Regulation?

ANSWER: The regulation places a duty on all employers and self-employed persons to ensure the electrical systems in their premises are, effectively safe.

The regulation does not impose on, amongst others, manufacturers or suppliers of such electrical systems. However, rest assured that all Xerox equipment which Xerox and its authorised distributors

supplies to customers, conform with all the relevant safety legislation and standards.

QUESTION: Is Xerox equipment safe?

ANSWER: All Xerox equipment supplied by Xerox and their authorised distributors conform to all relevant safety legislation and standards.

QUESTION: Is the Xerox equipment in my premises safe?

ANSWER: All Xerox equipment supplied by Xerox and its authorised distributors conform to all relevant safety legislation and standards. However, like all electrical equipment, they have to be regularly serviced and maintained by competent persons.

Xerox Customer Service Engineers ensure Xerox equipment is serviced and maintained to exacting Xerox safety standards. If you would like your Xerox equipment to be serviced and maintained to such high standards, please contact your local Xerox Customer Service Organisation. They will be pleased to assist you.

QUESTION: Does the Xerox equipment in my premises comply with the Electricity at Work Regulations?

ANSWER: All employers and self-employed persons must ensure that the electrical systems in their premises are safe. This will include ensuring Xerox equipment in such premises is safe.

Xerox Product Safety function has prepared a guide which contains a list of tests which may be completed by your Xerox Customer Service Organisation. **THESE TESTS MUST BE CARRIED OUT ONLY BY PERSONS WHO POSSESS THE RELEVANT SKILL, KNOWLEDGE AND EXPERIENCE TO CARRY OUT SUCH TESTS.**

Please contact the Xerox Customer Service Organisation for further information.

THE USE OF INAPPROPRIATE TEST PROCEDURES AND TEST EQUIPMENT MAY PROVIDE MISLEADING RESULTS AND MAY CAUSE DEATH, PERSONAL INJURY AND/OR DAMAGE TO PROPERTY.

QUESTION: I would like to carry out my own safety tests on the Xerox equipment in my premises.

ANSWER: You may, of course, request such tests as you deem necessary to satisfy yourself that your Xerox equipment is safe. Your Xerox Customer Support will be pleased to advise you on such testing.

QUESTION: I require records of all tests

ANSWER: After safety testing, your Xerox Customer Service Engineer will provide you with a certificate which details the results of all tests completed.

In the event of any defect being noted, the Xerox equipment will be switched off and disconnected from the supply until the defect has been corrected. You will be advised of such action to enable such defects to be corrected.

PLEASE NOTE: YOU MUST ENSURE THAT YOUR XEROX EQUIPMENT IS SAFE AT ALL TIMES

Please contact us if you have any queries regarding the information provided in this document.

Xerox Product Safety,
Bessemer Road,
Welwyn Garden City,
Herts AL7 1HE, England

Radio Equipment & Telecommunications Terminal Equipment Directive 99/5/EC

The Xerox Document Centre RDT modem option has been self-certified by Xerox (Europe) Limited in accordance with Directive 99/5/EC and has been designed to work with the national analogue public switched telephone networks (PSTN) and compatible PBXs of the following countries:

Austria	Germany	Luxembourg	Sweden
Belgium	Greece	Netherlands	Switzerland
Denmark	Iceland	Norway	United Kingdom
France	Ireland	Portugal	
Finland	Italy	Spain	

In the event of problems, you should contact your local Xerox representative in the first instance.

The modem may be configured to be compatible with other country networks. Please contact your Xerox representative if the modem needs to be reconnected to another country's network. There are no user-adjustable settings in the modem.

NOTE: Although the modem can use either loop disconnect (pulse) or DTMF (tone) signalling it is recommended that it is set to use DTMF signalling. DTMF signalling provides reliable and faster call set-up.

Modification, connection to external control software or to external control apparatus not authorised by Xerox, will invalidate the product's certification.

Table of Contents

1. Introduction

How to Use this Document	1-2
Document Centre Options	1-3
Conventions used in this document.....	1-4
Other Sources of Information.....	1-5
ST Model Features	1-7

2. How to Connect to Ethernet or Token Ring Networks

Before You Connect to a 100BaseT Ethernet Network	2-1
How to set the Ethernet Speed	2-2
Before You Connect to a Token Ring Network	2-3
How to set the Ring Speed and Source Routing	2-4
How to set the Hardware (MAC) Address	2-5

3. Dynamic/Static IP Addresses and WINS

Before you start	3-1
Dynamic Addressing (DHCP, BOOTP, or RARP).....	3-2
Static Addressing.....	3-6
Windows Internet Name Service (WINS) Installation.....	3-10
Where to go from here	3-13

4. CentreWare Device Admin Wizard

Before you start	4-1
Go to the Document Centre and... ..	4-2
Go to the workstation and... ..	4-3
Go to the Document Centre and... ..	4-3
Go to a workstation and... ..	4-4

5. Novell NetWare 4.X and 5.X (NDS) Networks

Before You Start.....	5-1
Go to the Document Centre and... ..	5-2
Go to a workstation and... ..	5-5

6. Novell NetWare 3.1x or 4.x/5.x in Bindery Mode

Before you start	6-1
Go to the Document Centre and... ..	6-2
Go to a workstation and... ..	6-6

7. UNIX Networks

Before You Start.....	7-1
If you have not already assigned TCP/IP information... ..	7-2

Go to a workstation and.....	7-3
8. Microsoft (NetBEUI) Networks	
Before You Start.....	8-1
Go to the Document Centre and...	8-2
Go to the workstations and.....	8-5
9. Microsoft (TCP/IP) Networks	
Before You Start.....	9-1
If you have not already assigned TCP/IP information...	9-2
Go to the Document Centre and...	9-3
Go to the workstation and.....	9-6
10. Windows 2000 LPR and IPP Printing	
Before you Start.....	10-1
If you have not already assigned TCP/IP information...	10-2
Go to the Server/Workstation and...	10-3
11. Microsoft Windows NT 4.X Server Network (TCP/IP)	
Before you Start.....	11-1
If you have not already assigned TCP/IP information...	11-2
Go to the server and.....	11-3
Go to the workstation and.....	11-5
12. OS/2 (TCP/IP) Networks	
Before You Start.....	12-1
If you have not already assigned TCP/IP information...	12-2
Go to a workstation and.....	12-3
13. OS/2 (NetBEUI) Networks	
Before You Start.....	13-1
Go to the Document Centre and...	13-2
Go to the workstations and.....	13-5
14. Macintosh Networks (AppleTalk)	
Before you start	14-1
Go to the Document Centre and...	14-2
Go to the workstation and.....	14-4
15. Banyan VINES Network	
Go to the Document Centre and...	15-1
Go to the server and.....	15-4
16. Internet Services	
Overview	16-1
Who should read this chapter	16-3
Before You Start.....	16-4
Browser Configuration	16-6
Internet Services Interface Features	16-8
Administration Logon	16-11
Internet Services Use.....	16-12
Print Documents with Job Submission on the Services Page.....	16-13
Scanning Documents	16-17

Template Management.....	16-19
Distribution Templates.....	16-21
Template Settings.....	16-22
Deleting Distribution Templates.....	16-32
Copying Distribution Templates.....	16-33
Updating the Template List at the Document Centre.....	16-33
Manage Jobs with Internet Services.....	16-34
Active Jobs.....	16-35
Deleting Jobs.....	16-36
View Document Centre Status with Internet Services.....	16-37
Viewing Active Alert Messages.....	16-38
Viewing Tray Status.....	16-39
View Document Centre Properties with Internet Services.....	16-40
Configuration.....	16-42
Billing Counters.....	16-43
Job Management.....	16-44
Connectivity.....	16-45
Services.....	16-77
Testing the Document Centre.....	16-104
Maintenance.....	16-104
Getting Support.....	16-109
Viewing Support Information.....	16-110
Problem Solving.....	16-111
17. Network Troubleshooting	
Overview.....	17-1
TCP/IP Troubleshooting.....	17-2
NetWare Troubleshooting.....	17-5
Microsoft (NetBIOS/NetBEUI) Troubleshooting.....	17-7
OS/2 Troubleshooting (TCP/IP).....	17-9
AppleTalk Troubleshooting.....	17-11
Banyan VINES Troubleshooting.....	17-13
18. Network Accounting	
Overview.....	18-1
Before You Start.....	18-3
Go to the Document Centre and.....	18-4
Go to the workstation and.....	18-6
Network Accounting Troubleshooting.....	18-8
19. Network Fax	
FAX Installation for FTP.....	19-2
FAX Installation for IPX/SPX.....	19-5
Network FAX Troubleshooting.....	19-8
20. Scan Setup without CentreWare	
Terminology used in this Chapter.....	20-2
Who Should Use This Guide.....	20-3

What to Do Next.....	20-4
Scanning Overview	20-5
Scanning with the Document Centre	20-6
Scan Templates.....	20-7
The Scanning Process.....	20-8
Overview of Repositories	20-11
Set Up Scanning - NetWare	20-15
Before You Start.....	20-15
Set Up Options	20-16
General Installation Requirements	20-18
Set Up Scanning (NetWare)	20-19
Test scanning	20-21
Set Up Scanning - FTP (File Transfer Protocol)	20-24
Before you start	20-24
Set up options	20-24
General Installation Requirements	20-27
Set up scanning (TCP/IP)	20-28
Test scanning	20-30
Hints and Tips.....	20-32
Installation Considerations	20-34
Scan Troubleshooting	20-36
Error Messages	20-37
21. E-mail	
Overview	21-1
Before You Start.....	21-2
Internet Messaging	21-3
HTTP	21-4
Enable E-mail	21-5
Configuring SMTP	21-6
Configuring E-mail.....	21-8
LDAP Directory Setup (Internal Address Book)	21-10
Important Information about E-mail Access.	21-12
Public Address Book	21-13
Authentication	21-15
E-mail Troubleshooting.....	21-17
22. Port 9100 Printing	
Go to the Document Center and... ..	22-3
Go to a workstation and.....	22-6
Glossary	
Index	

1. Introduction

This document provides an experienced Systems Administrator with information for setting up and troubleshooting the Document Centre family of products on the various networks indicated.

Requirements

This document assumes you have purchased your printer with the integrated network interface or have purchased a Token Ring network interface upgrade kit separately and it has been installed using the instructions provided.

In general, the requirements needed for connection and setup include:

- A working knowledge of your network.
- Appropriate cabling to connect your printer to your network.
- A workstation with the appropriate operating system software installed for that station connected to the same network as the printer.
- CentreWare Admin Services CD-ROM to install CentreWare applications.
- CentreWare Network Services CD-ROM to install print drivers.

How to Use this Document

This document has been arranged to get the printer set up on your network quickly and with minimum reading.

1. Before connecting network cabling to the Document Centre device, perform the procedure contained in this document entitled **How to Connect to Ethernet / Token Ring Networks**.
2. For Dynamic TCP/IP addressing refer to the section entitled **Dynamic/Static IP Addresses and WINS**.
3. Review the Table of Contents in this document. Find the network operating system (NOS) or protocol, which pertains to your network.
4. Go to the page indicated and perform the procedure(s).
5. Once you are finished it is recommended you print a test page.
6. Check the print job for print quality. If print quality problems exist, use the **Problem Solving** section of the **Reference Guide** to correct the problem.
7. If your print job **DID NOT** print, see the Troubleshooting section for your operating system in this document to correct the problem.
8. Once your Document Centre is installed and printing, you can repeat these steps to enable your printer to print with additional protocols or network operating systems.

NOTE

For detailed safety information about this product refer to the **Document Centre Reference Guide**.

Document Centre Options

The Document Centre can be used as a high speed scan device. You can use Xerox CentreWare Scanning Admin Wizard to configure your Document Centre as a network scanner if you have a workstation on your network that has a 32 bit version of Windows. Details on this are available in the document supplied with your Document Centre entitled **CentreWare Network Scanning Services Guide**.

For installation instructions on connecting your Document Centre as a scanner without the use of CentreWare, refer to the section in this document entitled **Scan Setup without CentreWare**.

The Document Centre also supports Network Accounting software. For installation instructions on connecting to an OfficeTrac server, refer to the section in this document entitled **Network Accounting**.

The Document Centre supports Network Fax Solutions that allow it to be used as a high speed fax device. For installation instructions on connecting to a hardware or software solution, refer to the section in this document entitled **Network Fax Solutions**.

Conventions used in this document

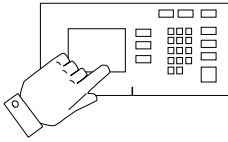

This symbol indicates that entries will be made on the printer's keypad or Touch Screen.

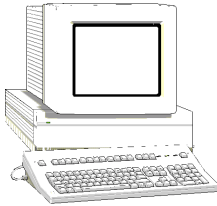

This symbol indicates that entries will be made at a workstation or fileserver.

NOTE

When you see this text in the left margin, it indicates the text to the right is of special importance and should be read before proceeding.

Setup and Copy / Scan / Fax features information:

- The **Reference Guide** provides detailed information about all features and settings as well as maintenance.
- The **User Guide** provides information and instructions about using the features of the machine to perform copy, scan, fax, and e-mail tasks.
- The **Help** system provides you point-of-need information.

CentreWare information:

- **CentreWare Network Services Guide** (hard copy). This document contains information about installation procedures for Xerox CentreWare print and fax drivers and installation and use of the features of the Xerox CentreWare Network Services software.
- **CentreWare Help Centre and Context-Sensitive Help Systems** (Electronic Help). This electronic documentation is supplied with the CentreWare software and can be viewed on the client workstation.

Xerox on the Web

- Use the Document Centre web site to get the latest information about the Xerox Document Centre:

<http://www.documentcentre.xerox.com>

- Download the latest CentreWare drivers at

<http://www.centreware.com>

- For more information about other Xerox products visit the Xerox Corporation main page at:

<http://www.xerox.com>

ST Model Features

What is the ST?

The ST model has the ability to make copies as well as print. ST models have full copy (and optional Network Scanning, Scan to E-mail, Network Faxing, Network Accounting) capability .

Document Feeder and Scanner

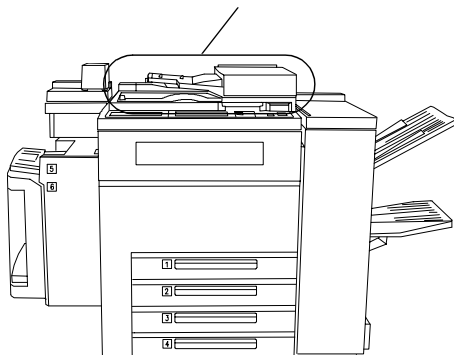

User Interface

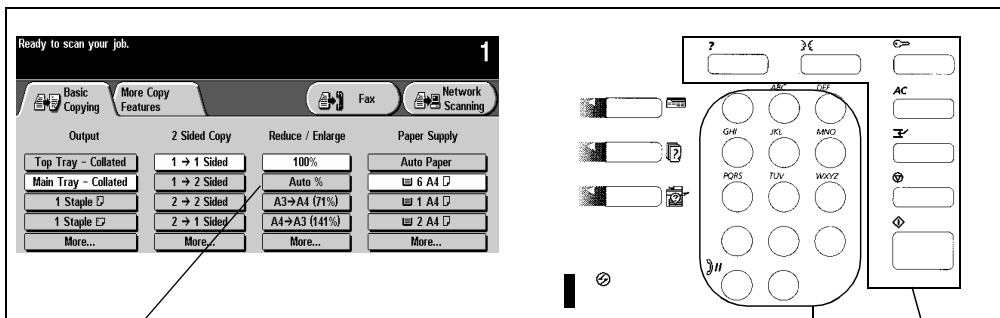

Touch Screen

Keypad

Feature Buttons

Network Connections

Use UTP/STP (Category 3 or 5 for 10Mbps Ethernet, Category 5 for Token Ring or 100Mbps Fast Ethernet) type of cable to connect to the network as indicated below.

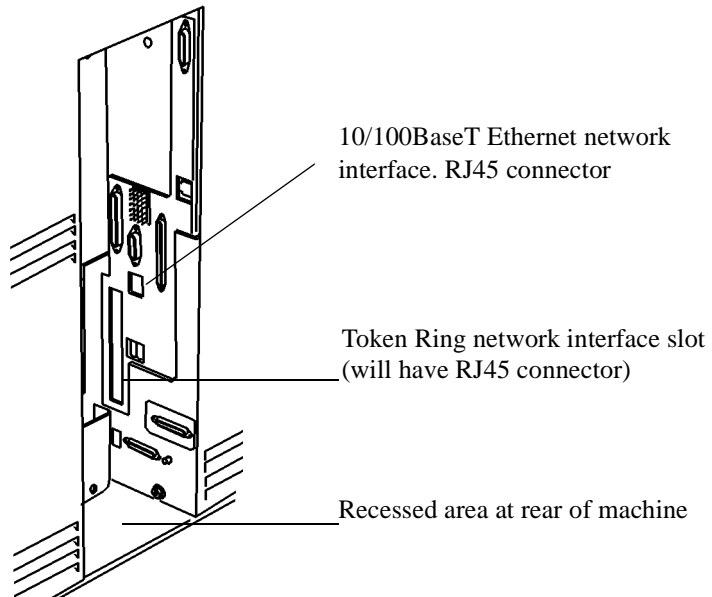

2. How to Connect to Ethernet or Token Ring Networks

Before You Connect to a 100BaseT Ethernet Network

The Document Centre Ethernet Interface has speed settings of **10Mbps (10 Megabits per second)**, **100Mbps (100 Megabits per second)** and **Auto (AutoSensing)**. If your network has hubs or concentrators that have Auto-Sensing enabled, it is possible that if the Document Centre is set to **Auto**, the hub/concentrator will not arbitrate to the correct speed.

Before you connect the printer to your network, perform the procedure on the next page entitled **How to set the Ethernet Speed**.

How to set the Ethernet Speed

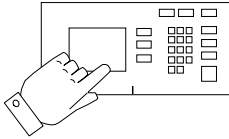

1. Enter the **Tools** pathway
 - a) Press the **Access** (**A** or ) button.
 - b) On the keypad enter **1111** or the current password. Press the **Enter** button when finished. The Touch Screen will be used for the remainder of the data entry, unless instructed otherwise.
 - c) Press the **Go to Tools** button.
2. Set or Change the Network Connection Speed.
 - a) Wait for the screen to refresh and press the **Connectivity and Network Setup** button.
 - b) Wait for the screen to refresh and press the **Physical Media** button.
 - c) Press the **Ethernet** button.(If available.)

NOTE

Auto-Sensing hubs may not arbitrate correctly with the Document Centre when **Auto** is selected. If your hubs/concentrators support the 100BaseT speed it is recommended you select **100Mbps** in Step d below. (Be sure your Ethernet cable is Category 5)

- d) Select the desired Speed **10Mbps, 100Mbps, or Auto.**
 - e) When finished with your changes press **Save.**
3. Press the **Exit Tools** button.
4. **Wait a MINIMUM of 7 minutes** for the printer to reset. The Network Controller is being reset and initializing with the new setup. When complete a Configuration Report will print.
 - a) Obtain the **Configuration Report** page from your printer and verify that your settings have been retained.
5. Connect your Document Centre to the network with the appropriate cabling.

Before You Connect to a Token Ring Network

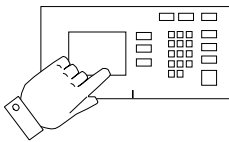

If your printer is equipped with a Token Ring interface, to avoid problems with your network you must configure the correct Ring Speed and Source Routing settings for your environment prior to connecting the printer to your network.

The default settings for the Ring speed and Source Routing are **16Mbps** and **None** respectively. If you do not need to change these then you do not need to read any further in this chapter.

NOTE

As with any other Token Ring device, connecting the Document Centre Token Ring card to your network while it is set at the incorrect Ring Speed can cause severe problems on your network.

Before you connect the printer to your network, perform the procedure on the next page entitled **How to set the Ring Speed and Source Routing**.

How to set the Ring Speed and Source Routing

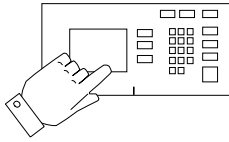

1. Enter the **Tools** pathway
 - a) Press the **Access** (**A** or ) button.
 - b) On the keypad enter **1111** or the current password. Press the **Enter** button when finished. The Touch Screen will be used for the remainder of the data entry, unless instructed otherwise.
 - c) Press the **Go to Tools** button.
2. Set or Change the Ring Speed or Source Routing.
 - a) Wait for the screen to refresh and press the **Connectivity and Network Setup** button.
 - b) Wait for the screen to refresh and press the **Physical Media** button.
 - c) Press the **Token Ring** button.
 - d) Press the **Token Ring Settings** button.
 - e) Select the desired Ring Speed (**4 Megabits** or **16 Megabits** per second).
 - f) Select the desired method of Source Routing (**Single Route Broadcast** or **All Route Broadcast**).
 - g) When finished with your changes press **Save**.
3. Press the **Exit Tools** button.
4. **Wait a MINIMUM of 7 minutes** for the printer to reset. The Network Controller is being reset and initializing with the new setup. When complete a Configuration Report will print.
 - a) Obtain the **Configuration Report** page from your printer and verify that your Token Ring Settings have been retained.
5. Connect your Document Centre to the network with the appropriate cabling.

How to set the Hardware (MAC) Address

All Document Centre printers equipped with a Token Ring interface have a default MAC address. It is **STRONGLY** recommended that you use caution when changing the MAC Address of the network interface.

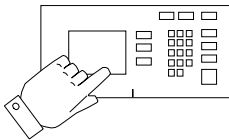

1. Access the **Tools** pathway.
 - a) Press the **Access** (**A** or ) button.
 - b) On the keypad enter **1111** or the current password. Press the **Enter** button when finished. The Touch Screen will be used for the remainder of the data entry, unless instructed otherwise.
 - c) Press the **Go to Tools** button.
2. Set or Change the MAC address.
 - a) Wait for the screen to refresh and press the **Connectivity and Network Setup** button.
 - b) Wait for the screen to refresh and press the **Physical Media** button.
 - c) Press the **Token Ring** button.
 - d) Press the **Token Ring Settings** button.
 - e) Press the **MAC Address** button.
 - f) Enter the six (6) hexadecimal pairs on the touch keypad separated by colons.
 - g) When finished press **Save**.
 - h) Press the **Exit Tools** button.
3. **Wait a MINIMUM of 7 minutes** for the printer to reset. The Network Controller is being reset and initializing with the new setup. When complete a Configuration Report will print.
 - a) Obtain the **Configuration Report** page from your printer and verify that your Token Ring Settings have been retained.
4. Connect your Document Centre to the network with the appropriate cabling.

3. *Dynamic/Static IP Addresses and WINS*

Before you start

NOTE

Your Document Centre now has DHCP, LPR, and NetBIOS over the IP protocol enabled by default. If your DHCP server will provide host name, IP address, Gateway address, and Subnet Mask, the Document Centre TCP/IP information will be configured on initial boot.

Your Document Centre printer can be connected to a variety of networks that use the TCP/IP protocol. You may either choose to allow the device to retrieve a dynamic address or you may select to enter one manually. This section contains procedures for both of these methods. Determine which method will be used for your network and follow the steps of the appropriate procedure.

Dynamic Addressing (DHCP, BOOTP, or RARP)

If your printer is equipped with a Token Ring interface, prior to connecting your printer to your network, use the section of this document entitled **Token Ring Interface Network Connection** to set the Ring Speed and Source Routing settings for your environment. Then return to this procedure and follow the instructions

The Document Centre supports two methods of Dynamic Addressing:

DHCP (Dynamic Host Configuration Protocol) or BOOTP

RARP (Reverse Address Resolution Protocol)

The TCP/IP address is assigned automatically by a DHCP server. Follow the steps below:

NOTE

By default, DHCP is enabled on the Document Centre. This procedure will show you how to disable DHCP (or enable it if it was disabled) and set your TCP/IP information using BOOTP or RARP.

DHCP/BOOTP/RARP servers vary in the information that they return to the device requesting service. Consult the documentation supplied with your DHCP or RARP server software to verify what TCP/IP information it can supply. Your Document Centre can retrieve the following values from DHCP, BOOTP, and RARP servers:

TCP/IP Address

Host Name (*DHCP Only*)

Subnet Mask

Gateway TCP/IP Address

Broadcast Address (*DHCP only*)

Domain Name (*DHCP only*)

Preferred and Alternate DNS Server (*DHCP only*)

Wins Server (*DHCP only*)

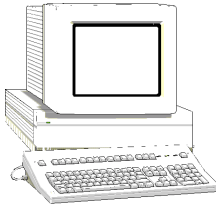

Go to the dynamic server and...

1. Configure the DHCP, BOOTP, or RARP server with the TCP/IP information you want assigned to your printer. Use the documentation supplied with your server software for this task.

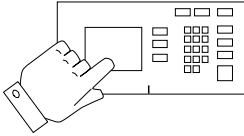

Go to the Document Centre and...

2. Connect your Document Centre to the network with the appropriate cabling.
3. Enter the **Tools** pathway
 - a) Press the **Access** (**A** or ) button.
 - b) On the keypad enter **1111** or the current password. Press the **Enter** button when finished. The Touch Screen will be used for the remainder of the data entry, unless instructed otherwise.
 - c) Press the **Go to Tools** button.
4. Enter the Network Setup menus.
 - a) Wait for the screen to refresh and press the **Connectivity and Network Setup** button.
 - b) Wait for the screen to refresh and press the **Network Setup** button.
 - c) Press the **TCP/IP Options** button.
5. Enable TCP/IP printing.
 - a) Press the **TCP/IP Settings** button.
 - b) Press the **Protocol and Media** button.
 - c) Press the **Enable** button. If Physical Media buttons appear, select either **Ethernet** or **Token Ring**. Press **Save**.

6. Select either DHCP, BOOTP, or RARP as the dynamic address source.
 - a) Press the **Dynamic Addressing** button. By default, DHCP will be selected. To disable DHCP, choose another dynamic addressing method (BOOTP, DHCP, DHCP/AutoNet, RARP) or **Disabled**, and press **Save**.
 - b) Press the **Exit Tools** button. Wait approximately 2 minutes before you continue to Step 7.
7. Print a **Configuration Report** page to verify the DocuCentre TCP/IP information was assigned correctly by the dynamic server.
 - a) Repeat Steps 3a and 3c.
 - b) Select **System Setting**.
 - c) Select **Configuration Report**.
 - d) Select **Print Configuration Report Now**.
 - e) Press the **Cancel** button.
 - f) Press the **Exit Tools** button.
8. Set the Host Name
 - a) Repeat Steps 3a - 5a.
 - b) Press the **Name/Address** button.
 - c) Press the **Host Name** button.
 - d) By default, the Document Centre assigns a default host name. To change the host name, type the host name EXACTLY as you want it to appear with correct case. When finished press the **Save** button to record the changes and exit to the **TCP/IP Settings** screen.

NOTE

The Document Centre will only accept one Gateway address from a DHCP server.

9. Set Subnet Mask and Gateway Address.
 - a) Press the **Subnet and Gateway** button.
 - b) Press the soft buttons on the Touch Screen one at a time for each octet of the Subnet Mask and enter the numbers from the keypad.

- c) Repeat this process for the IP Gateway address. When finished press **Save** to record the changes and exit to the **TCP/IP Settings** screen.
 - d) Press the **Close** button.
10. Enable LP and LPR printing.
- a) Press the **TCP/IP - Line Printer** button.
 - b) Press the **Enable** button.

NOTE

While you can change the port number at which your Document Centre will accept lpr print jobs it is recommended that you do this **ONLY** with extreme caution as most lpr spoolers are set to send print jobs to the default port.

- c) If you wish to change the lpr port for your printer press the **Port Number** soft button and enter the desired port number at the keypad. Press **Save**.
 - d) Press the **Close** button.
11. Enable HTTP/IPP
- a) Press the **HTTP/IPP** button. At the next screen press the **Enable** button. Then press **Save**.
 - b) Press the **Exit Tools** button.
12. Verify printer settings.
- a) Print a **Configuration Report** page to verify the TCP/IP information was assigned correctly. (see step 7.)

NOTE

Update the lease time (if necessary) at the DHCP or BOOTP server depending on your printer usage patterns. Consult your server documentation for details.

NOTE

If your RARP Sever does not dynamically update its **etc/ethers** and **etc/hosts** files with a host name, you need to do this manually. Consult your RARP or BOOTP server documentation for details.

Static Addressing

NOTE

Your Document Centre now has DHCP, LPR, and NetBIOS over the IP protocol enabled by default. If you have a DHCP server and it is set to provide host name, IP address, Gateway address, and Subnet Mask, the Document Centre TCP/IP information will be configured on initial boot. This procedure assumes you will set the IP information manually.

To enable 100BaseT or a Token Ring interface, refer to Chapter 2 **How to Connect to Ethernet or Token Ring Networks** to configure the Speed and Source Routing settings for your environment.

For information on how your printer can connect to a DHCP, BOOTP, or a RARP server to be assigned an IP address dynamically, refer to the section in this chapter entitled **Dynamic Addressing (DHCP, BOOTP, or RARP)**.

Go to the Document Centre and...

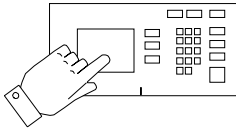

1. Connect your Document Centre to the network with the appropriate cabling.
2. Enter the **Tools** pathway.
 - a) Press the **Access** (**A** or ) button.
 - b) On the keypad enter **1111** or the current password. Press the **Enter** button when finished. The Touch Screen will be used for the remainder of the data entry, unless instructed otherwise.
 - c) Press the **Go to Tools** button.
3. Enter the Network Setup menus.
 - a) Wait for the screen to refresh and press the **Connectivity and Network Setup** button.
 - b) Wait for the screen to refresh and press the **Network Setup** button.
4. Enable TCP/IP protocol.
 - a) Press the **TCP/IP Options** button.
 - b) Press the **TCP/IP Settings** button.
 - c) Press the **Protocol and Media** button.
 - d) Press the **Enable** button. If Physical Media buttons appear, select either **Ethernet** or **Token Ring**. Press **Save**.
5. Select either DHCP, BOOTP, or RARP as the dynamic address source.
 - a) Press the **Dynamic Addressing** button. By default, DHCP will be selected. To disable DHCP, choose another dynamic addressing method or **Disabled**. Press **Save**.
6. To enter the IP address and Host Name.
 - a) Press the **Name/Address** button.
 - b) Press the soft buttons one at a time on the touch screen for each Octet of the IP address and enter the numbers from the keypad.

- c) Press the **Host Name** button.
- d) When the soft keypad appears, type the SMB host name EXACTLY as you want it to appear with proper case. When finished press the **Save** button twice to record the changes and exit to the **TCP/IP Settings** screen.

Subnet and Gateway.

- 7. To enter a Subnet Mask and Gateway Address.
 - a) Press the **Subnet and Gateway** button.
 - b) Press the soft buttons one at a time on the Touch Screen for each Octet of the Subnet Mask and enter the numbers from the keypad.
 - c) Repeat this process for the IP Gateway address. When finished press **Save** to record the changes and exit to the **TCP/IP Settings** screen.
 - d) Press the **Close** button.

NOTE

The Broadcast Address will be calculated automatically.

- 8. To enable LP and LPR printing...
 - a) Press the **TCP/IP - Line Printer** button.
 - b) Press the **Enable** button.

NOTE

While you can change the port number at which your Document Centre will accept lpr print jobs it is recommended that you do this ONLY with extreme caution as most lpr spoolers are set to send print jobs to the default port.

- c) If you wish to change the lpr port for your printer press the **Port Number** soft button and enter the desired port number at the keypad. Press **Save**.

9. Enable HTTP/IP.
 - a) Press the **HTTP/IPP** button.
 - b) Press **Enable**.
 - c) Press **Save**.
10. Print a **Configuration Report** page to verify the DocuCentre TCP/IP information was assigned correctly.
 - a) Repeat Steps 3a and 3c.
 - b) Select **System Setting**.
 - c) Select **Configuration Report**.
 - d) Select **Print Configuration Report Now**.
 - e) Press the **Cancel** button.
 - f) Press the **Exit Tools** button.

Windows Internet Name Service (WINS) Installation

Before You Start

If your printer is equipped with a Token Ring interface, use the **100BaseT Ethernet or Token Ring Quick Install Card** supplied in this Quick Install Card set to configure the Ring Speed and Source Routing settings for your environment.

Your Document Centre now has DHCP, LPR, and NetBIOS over the IP protocol enabled by default. If your DHCP server will provide the IP address, Gateway address, Subnet Mask for the Document Centre, and WINS server address(es), the TCP/IP information will be configured on initial boot. This means that if you have configured your DHCP server with the desired information, you may connect your Document Centre to your network and it will boot and register with the WINS server automatically.

NOTE

Your DHCP server must return at least one (1) WINS server address to the Document Centre in order to enable WINS registration.

In this mode the default NetBIOS host name, SMB host name and the DNS host name for the device will be the letters **XXR** followed by the MAC address of the network interface.

Example:
XXR08003E313E0A

If this NetBIOS host name is acceptable you can go right to the section in the next section entitled **Go to the Workstation and....** and complete those steps.

To change the **NetBIOS host name** for your printer follow Steps 1, 2, and 3 then skip to Step 5 and finish the **Go to the Document Centre...** portion. When you finish that section, go to the section entitled **Go to the Workstation and....** and complete those steps.

Go to the Document Centre and...

1. Connect your Document Centre to the network with the appropriate cabling.
2. Enter the Tools pathway.
 - a) Press the **Access** () button.
 - b) On the keypad enter **1111** or the current password. Press the **Enter** button when finished. The Touch Screen will be used for the remainder of the data entry, unless instructed otherwise.
 - c) Press the **Go to Tools** button.
3. Enter the Network Setup menus.
 - a) Wait for the screen to refresh and press the **Connectivity and Network Setup** button.
 - b) Wait for the screen to refresh and press the **Network Setup** button.
 - c) Press the **Microsoft Networks** button.
4. Enable the Transport and Media.
 - a) Press the **Transport and Media** button.
 - b) Press the **Enable** button. If Physical Media buttons appear, select either **IP/Ethernet** or **IP/Token Ring**. Press **Save**.
5. Set the NetBIOS Host Name.
 - a) Press the **Workgroup and Host** button.
 - b) Press the **SMB Host Name** (this is the same as the NetBIOS host name) button.
 - c) When the soft keypad appears, type the host name **EXACTLY** as you want it to appear with correct case. When finished press the **Save** button to record the changes and exit to the Workgroup and Host Screen.

6. Exit the Tools Menu.
 - a) Press the **Exit Tools** button.
 - b) The Document Centre will reconfigure itself with the new settings and automatically register its TCP/IP address and NetBIOS host name with your WINS server.

Go to the workstation and...

1. Create a new lpr printer on the NT workstation.
 - a) With an LPR port as the desired destination, enter the Microsoft Networking host name.
 - b) Enter a queue name to identify the printer.
 - c) When prompted, select the desired PostScript or PCL driver from the **Xerox CentreWare Network Services CD** or directory where drivers are stored.

Where to go from here

After you have verified that the TCP/IP information you have assigned to your Document Centre is correct, go to the section of this document that applies to your network operating system or protocol and perform the procedures indicated:

Unix Networks - Chapter 7

Microsoft (TCP/IP) Networks - Chapter 9

Windows 2000 LPR and IPP Printing - Chapter 10

Microsoft Windows NT 4.X Server Network (TCP/IP) - Chapter 11

OS/2 (TCP/IP) Networks - Chapter 12

If you prefer there are also a Quick Install Cards for this process supplied with your Document Centre. Please refer to the following cards:

UNIX/Linux (Solaris/SunOS) (HP-UX) (AIX) Quick Install Card

Microsoft Windows NT 4.0 Server (TCP/IP) Quick Install Card

Microsoft Windows 200 LPR and IPP Printing Quick Install Card

Port 9100 TCP/IP Printing Quick Install Card

4. CentreWare Device Admin Wizard

Before you start

This procedure assumes you have already installed CentreWare applications on a Windows 95/98, Windows ME , Windows NT4.0 Workstation and Windows 2000 Professional. If you have not done so, detailed instructions for installation are contained in the **CentreWare Network Services Guide**. This document was supplied with your printer.

In order to use the CentreWare Device Admin Wizard for installation, you must login to the fileserver or Tree with Supervisor or Administrator privileges. Additionally, You will need the following NetWare information:

NDS Tree (NetWare 4.X and 5.X environment)

NDS Context (NetWare 4.X and 5.X environment)

Primary Fileserver (NetWare 3.X environment)

Frame Type

Go to the Document Centre and...

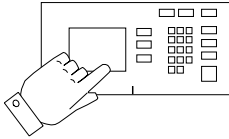

1. Connect your Document Centre to the network with the appropriate cabling.
2. Enter the Tools Menu.
 - a) Press the **Access** (**A** or ) button.
 - b) On the keypad enter **1111** or the current password. Press the **Enter** button when finished. The Touch Screen will be used for the remainder of the data entry, unless instructed otherwise.
 - c) Press the **Go to Tools** button.
3. Enable the Network Protocol.
 - a) Wait for the screen to refresh and press the **Connectivity and Network Setup** button.
 - b) Wait for the screen to refresh and press the **Network Setup** button.
 - c) Press the **NetWare** button.
 - d) Wait for the screen to refresh and press the **Protocol and Media** button.
 - e) Press the **Enable** button. If Physical Media buttons appear, select either **Ethernet** or **Token Ring**. Press **Save**.
4. Set the Frame Type.
 - a) Press the **Frame Type** button.
 - b) Select the frame type desired then press **Save** to retain your changes and exit to the NetWare Options screen.
5. Exit the Tools Menu.
 - a) Press the **Exit Tools** button. The printer will store the settings you have made.

Go to the workstation and...

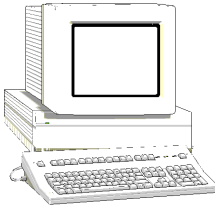

1. From the desktop click the **Start** button on the Task Bar.
2. Select the **Programs** entry in the menu.
3. From the cascade menu select the **Xerox CentreWare** entry.
4. On the next cascade menu select the **Device Admin Wizard**.
5. The Device Admin Wizard will start.
6. Follow the instructions on each Device Admin Wizard Screen to setup the Document Centre on your network. Context sensitive help is available for each step.

NOTE

You will be asked for a password, enter “**1111**” (or the current Admin password for your printer that you would enter from the keypad), then click OK.

7. The Device Admin Wizard will complete the installation by writing the settings to the Document Centre and the Novell Server.

Go to the Document Centre and...

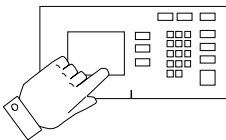

1. Power off and power on the Document Centre so the setup selections will take effect.
2. **Wait a MINIMUM of 7 minutes** for the printer to reset.

Go to a workstation and...

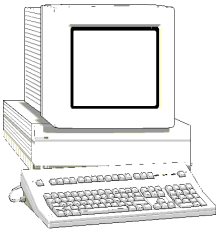

1. Use the **CentreWare Print and FAX Drivers CD-ROM** to install print drivers on a Windows-based workstation. Details for this are found in the document supplied with your printer entitled **Network Services Guide**.
2. Connect the print driver you loaded above to the queue you created on the NetWare server.
3. Open an application and print a test job.
4. Check your test job for quality and use the problem solving section of the **Document Centre Reference Guide** for resolving print defects.
5. If your test job does not print, refer to the troubleshooting section in this document to correct the problem.
6. Repeat this **Go to a workstation and...** procedure at each workstation that will print to this printer.

5. Novell NetWare 4.X and 5.X (NDS) Networks

Before You Start

NOTE

Your Document Centre may be installed on your network using Novell NDPS. The Xerox NDPS Agent, Documentation, and Print drivers are available from the Xerox Web Site www.xerox.com

To enable 100BaseT or a Token Ring interface, refer to Chapter 2 **How to Connect to Ethernet or Token Ring Networks** to configure the Speed and Source Routing settings for your environment.

The CentreWare software supplied with your printer can be used to set up your printer on your Novell network. For details refer to the document entitled **CentreWare Network Services Guide**.

This procedure assumes you ran NWADMIN or PCONSOLE to set up a print server object. Please refer to the documentation supplied by Novell to complete those tasks.

Record precisely (observe upper and lower case, dot notation etc.) the following: the **NDS Tree**, **NDS Context Name**, **frame type**, **Print Server Name**, and the **Print Server password**, that was assigned.

NOTE

ALL Print Servers you create must have a password. When your printer will service queues on multiple file servers, the Print Server name must be the same on all file servers and the Print Server password must be the same on all file servers.

Go to the Document Centre and...

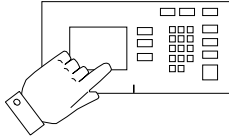

1. Connect your Document Centre to your network with the appropriate cabling.
2. Enter the **Tools** pathway.
 - a) Press the **Access** (**A** or ) button.
 - b) On the keypad enter **1111** or the current password. Press the **Enter** button when finished. The Touch Screen will be used for the remainder of the data entry, unless instructed otherwise.
 - c) Press the **Go to Tools** button.
3. Enable the Network Protocol.
 - a) Wait for the screen to refresh and press the **Connectivity and Network Setup** button.
 - b) Wait for the screen to refresh and press the **Network Setup** button.
 - c) Press the **NetWare** button.
 - d) Wait for the screen to refresh and press the **Protocol and Media** button.
 - e) Press the **Enable** button. If Physical Media buttons appear, select either **Ethernet** or **Token Ring**. Press **Save**.
4. Set the Frame Type.
 - a) Press the **Frame Type** button.
 - b) Select the frame type desired or **Auto** on Document Centre 490/480 then press **Save** to retain your changes and exit to the NetWare Options screen.

5. Set the NDS Settings.
 - a) Press the **NDS Settings** button.

Novell suggests using typeful names when entering Name Context and Directory Service Tree information.

TYPEFUL NAME EXAMPLE:

cn=contextname.ou=organization.o=company.c=country

- b) At this screen press the **Name Context** button and use the touch panel keyboard to enter the context in which this printer resides. To access numeric characters and punctuation, press the **More Characters or 123** button. When finished press **Save**.
 - c) Press the **Directory Service Tree** button and enter the NDS tree name where the Context chosen in the previous step resides. When finished press the **Save** button twice to record the changes.
6. Set the Print Server Name and Password.
 - a) Press the **Print Server** button.
 - b) Press the **Print Server Name** button and use the Touch Screen keyboard to enter the name you assigned to your print server (it is recommended you use all UPPER CASE characters). A default name will appear. Use the backspace key (it looks like an arrow pointing to the left) to clear out the default name prior to entering your new name. When finished press **Save** to retain the changes and return to the Print Server Screen.
 - c) Press the **Print Server Password** button. Use the Touch Screen keyboard to enter the print server password, in the correct case, you recorded when you set up your print server and press **Save**.
 - d) Press **Save** to exit the Print Server Screen and save your changes.

7. OPTIONAL STEP: To change the desired SAP rate or Poll Interval for your printer or set the Primary File Server.
 - a) Press the **Rates** button.
 - b) Press the box under **SAP Rate** or **Poll Interval** and enter the desired number from the keypad. The default values are recommended. When finished, press **Save** to retain your changes and return to the NetWare Options screen.
 - c) Press the **Primary File Server** button. At this screen press the **Name Context** button and use the touch panel keyboard to enter the context in which this printer resides. To access numeric characters and punctuation, press the **More Characters or 123** button. When finished press **Save**.
8. Exit the Tools Menu.
 - a) Press the **Exit Tools** button. The printer will store the settings you have made.
9. Prepare for print driver installation.
 - a) From the documentation package supplied with your printer, retrieve the **CentreWare Network Services CD-ROM** and the document entitled **CentreWare Network Services Guide**. Proceed to the next section of this procedure called **Go to a Workstation and...**

Go to a workstation and...

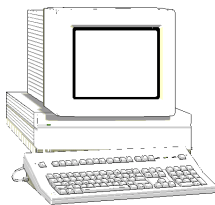

1. Use the **CentreWare Network Services CD-ROM** to install print drivers on a Windows-based workstation. Details for this are found in the document supplied with your printer entitled **CentreWare Network Services Guide**.
2. Connect the print driver you loaded above to the queue you created on the NetWare server.
3. Open an application and print a test job.
4. Check your test job for quality and use the problem solving section of the **Document Centre Reference Guide** for resolving print defects.
5. If your test job does not print, refer to the Troubleshooting section in this document to correct the problem.
6. Repeat this **Go to a workstation and...** procedure at each workstation that will print to this printer.

6. *Novell NetWare 3.1x or 4.x/5.x in Bindery Mode*

Before you start

To enable 100BaseT or a Token Ring interface, refer to Chapter 2 **How to Connect to Ethernet or Token Ring Networks** section to configure the Ring Speed and Source Routing settings for your environment.

The CentreWare software supplied with your printer can be used to set up your printer on your Novell network. For details refer to the document entitled **CentreWare Network Services Guide**. This procedure assumes you ran PCONSOLE to set up a print server. Please refer to the documentation supplied by Novell to complete this task. Record precisely (observe upper and lower case, punctuation etc.) the following: the **Primary Server name**, **Frame type** used, **Print Server name**, **Print Server password**, and the **Queue name** assigned.

NOTE

ALL Print Servers you create must have a password. When your printer will service queues on multiple file servers, the Print Server name must be the same on all file servers and the Print Server password must be the same on all file servers.

Go to the Document Centre and...

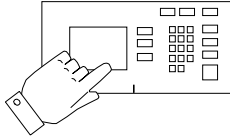

1. Connect your Document Centre to the network with the appropriate cabling.
2. Enter the **Tools** pathway.
 - a) Press the **Access** (**A** or ) button.
 - b) On the keypad enter **1111** or the current password. Press the **Enter** button when finished. The Touch Screen will be used for the remainder of the data entry, unless instructed otherwise.
 - c) Press the **Go to Tools** button.
3. Enable the Network Protocol.
 - a) Wait for the screen to refresh and press the **Connectivity and Network Setup** button.
 - b) Wait for the screen to refresh and press the **Network Setup** button.
 - c) Press the **NetWare** button.
 - d) Wait for the screen to refresh and press the **Protocol and Media** button.
 - e) Press the **Enable** button. If Physical Media buttons appear, select either **Ethernet** or **Token Ring**. Press **Save**.

4. Set the Primary File Server.
 - a) Press the **Primary File Server** button.
 - b) Press the upper-left keyboard icon button on the touch screen to set the first Primary File Server.
 - c) Use the touch panel keyboard and enter the name of the first Primary File Server to which you want the printer to connect. To access numeric characters and punctuation, press the **More Characters or 123** button. When finished press the **Save** button twice to record the changes.
 - d) You will be returned to the **NetWare Options** screen.
5. Set the Frame Type.
 - a) Press the **Frame Type** button.
 - b) Select the frame type desired or **Auto** on Document Centre 490/480 then press **Save** to retain your changes and exit to the **NetWare Options** screen.

6. Set the Print Server Name and Password.
 - a) Press the **Print Server** button.
 - b) Press the **Print Server Name** button and use the touch panel keyboard to enter the name you assigned to your print server (it is recommended you use all UPPER CASE characters). A default name will appear. Use the backspace key (it looks like an arrow pointing to the left) to clear out the default name prior to entering your new name. When finished press **Save** to retain the changes and return to the **Print Server** screen.
 - c) Press the **Print Server Password** button and use the Touch Screen keyboard to enter the print server password you recorded when you set up your print server and press **Save**.
 - d) Press **Save** to exit the Print Server screen and save your changes.
 - e) To change the desired SAP rate or its Poll Interval for your printer, press the **Rates** button.
 - f) Press the box under **SAP Rate** or **Poll Interval** and enter the desired number from the keypad. The default values are recommended. When finished, press **Save** to retain your changes and return to the NetWare Options screen.

7. Exit the Tools Menu.
 - a) Press the **Exit Tools** button. The printer will store the settings you have made.
8. Prepare for print driver installation.
 - a) From the documentation package supplied with your printer, retrieve the **CentreWare Network Services CD-ROM** and the document entitled **CentreWare Network Services Guide**. Proceed to the next section of this procedure called **Go to a Workstation and...**

Go to a workstation and...

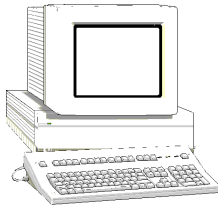

1. Use the **CentreWare Network Services CD-ROM** to install print drivers on a Windows-based workstation. Details for this are found in the document supplied with your printer entitled **CentreWare Network Services Guide**.
2. Connect the print driver you loaded above to the queue you created on the NetWare server.
3. Open an application and print a test job.
4. Check your test job for quality and use the Problem Solving section of the **Document Centre Reference Guide** for resolving print defects.
5. If your test job does not print, refer to the troubleshooting section in this document to correct the problem.
6. Repeat this **Go to a workstation and...** procedure at each workstation that will print to this printer.

7. UNIX Networks

Before You Start

To enable 100BaseT or a Token Ring interface, refer to Chapter 2 **How to Connect to Ethernet or Token Ring Networks** to configure the Ring Speed and Source Routing settings for your environment.

NOTE

Your Document Centre now has DHCP, LPR, and NetBIOS over the IP protocol enabled by default. If your DHCP server will provide host name, IP address, Gateway address, and Subnet Mask, the Document Centre TCP/IP information will be configured on initial boot. This means that if you have configured your DHCP server with the desired information, you may go right to the area within this section entitled **Go to a Workstation and...**

For information on how your printer can connect to a BOOTP server, or a RARP server to be assigned an IP address dynamically, refer to the section in this document entitled **Dynamic/Static IP Addresses & WINS**. Information in regards to static IP address configuration may be found within that section as well.

Your Document Centre printer supports printing from a variety of UNIX platforms. The procedure contained in this document will enable you to connect your printer in many of these environments.

If you have not already assigned TCP/IP information...

The preceding sections assume that any IP address, subnet mask, gateway, or host name necessary for network installation has already been assigned to the Document Centre. If these components have not been configured, please refer to the section of this document entitled **Dynamic/Static IP Addresses & WINS** before continuing further:

For Dynamic Addressing - Section 3, pages 3-2 thru 3-5.

For Static Addressing - Section 3, pages 3-6 thru 3-8.

Once the printer has been configured to the appropriate TCP/IP settings, you may proceed to the next section.

Go to a workstation and...

NOTE

This procedure assumes that any TCP/IP components necessary for network installation have already been assigned to the Document Centre. If these components have not been configured, please refer to the appropriate information contained within the section entitled **Dynamic/Static IP Addresses & WINS** before continuing further.

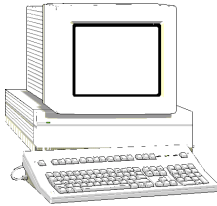

1. Mount the **CentreWare Network Services** CD-ROM . Solaris/SunOS, HP-UX, and AIX users can load the CentreWare Print DCPR Tool. Details are contained in the document entitled **CentreWare Network Services Guide**.
2. Add the printers host name, TCP/IP address, hardware address to your **/etc/hosts** file or **NIS database** depending on your UNIX version.
3. Create a queue using the CentreWare tool OR by using the native tools available in your operating system version.
4. Create a print job and send it to the printer.
5. Check your test job for quality and use the Problem Solving section of the **Document Centre Reference Guide** for resolving print defects.
6. If your print job does not print, refer to the Troubleshooting section in this document entitled **TCP/IP Troubleshooting** to correct the problem.
7. Repeat this **Go to a workstation and...** procedure at each workstation that will print to this printer.

8. *Microsoft (NetBEUI) Networks*

Before You Start

To enable 100BaseT or a Token Ring interface, refer to Chapter 2 **How to Connect to Ethernet or Token Ring Networks** to configure the Speed and Source Routing settings for your environment.

Go to the Document Centre and...

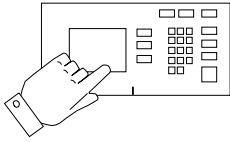

1. Connect your Document Centre to the network with the appropriate cabling.
2. Enter the **Tools** pathway.
 - a) Press the **Access** (**A** or ) button.
 - b) On the keypad enter **1111** or the current password. Press the **Enter** button when finished. The Touch Screen will be used for the remainder of the data entry, unless instructed otherwise.
 - c) Press the **Go to Tools** button.
3. Enable Microsoft Network printing.
 - a) Wait for the screen to refresh and press the **Connectivity and Network Setup** button.
 - b) Wait for the screen to refresh and press the **Network Setup** button.
4. Enable the Protocol and Media.
 - a) Press the **Microsoft Networks** button.
 - b) Press the **Transport and Media** button.
 - c) Press the **Enable** button to enable the Microsoft Network protocols.
 - d) If Physical Media buttons appear. Press the corresponding button to select either **NetBEUI/Ethernet** or **NetBEUI/Token Ring**. After making your selection press **Save**.

5. Assign the Workgroup and Host names.
 - a) You will be returned to the previous screen. Press the **Workgroup and Host** button.
 - b) At the next screen, press the **Workgroup Name** button, using the touch panel keys. Enter the name of the workgroup in which you want the printer to appear then press **Save**.
 - c) You will be returned to the previous screen. Press the **SMB Host Name** button. Using the Touch Screen, enter the desired text for this item then press **Save**.
 - d) **OPTIONAL STEP:** Press the **SMB Host Description** button, enter the desired text then press **Save**. You will be returned to the previous screen.
 - e) Press **Save** again to return to the previous screen.
6. Assign a Printer Name and Description.
 - a) Press the **Printer Description** button.
 - b) Press the **Printer Name** button. Using the touch panel keys, enter the desired text for this item. When finished press the **Save** button twice to record the changes.
 - c) **OPTIONAL STEP:** Press the **Printer Description** button, using the touch panel keys, enter the desired text for this item then press **Save**.

7. Set Maximum Connections and Timeout.
 - a) Press the **Connections** button.
 - b) Touch the **Maximum Connections** soft button on the Touch Screen and on the keypad enter the desired maximum connection number between 10 and 30. It is recommended that this value should be set at the default.
 - c) Touch the **Connection Timeout** soft button on the Touch Screen. On the keypad enter the desired number of seconds between 1 and 32,767 Press **Save** to exit the connections screen.
8. Exit the Tools Menu.
 - a) Press the **Exit Tools** button. The printer will store the settings you have made.
9. Print a **Configuration Report** page from your printer to use in the remainder of the installation.
 - a) Repeat Steps 2a and 2c.
 - b) Select **System Setting**.
 - c) Select **Configuration Report**.
 - d) Select **Print Configuration Report Now**.
 - e) Press **Cancel**.
10. Prepare for print driver installation.
 - a) From the documentation package supplied with your printer, retrieve the **CentreWare Network Services CD-ROM** and the document entitled **CentreWare Network Services Guide**. Proceed to the next section of this procedure called **Go to a Workstation and...**

Go to the workstations and...

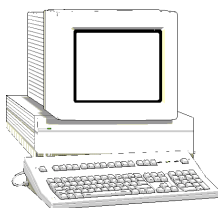

1. Verify that the **NetBEUI** protocol is loaded (ALL Windows 3.11 or greater versions).
2. Use the **CentreWare Network Services CD-ROM** to install print drivers on a Windows-based workstation. Details for this are found in the document supplied with your printer entitled **CentreWare Network Services Guide**.
3. On the Configuration Report review the **NetBIOS:** area and note the **Workgroup**, **Host Name**, and **Printer Name**.

Windows for Workgroups Users

- Open the **Control Panel** and double-click the **Printers** icon.
- Select the printer driver you just installed and click **Connect**.
- Select an available port and click **Network**.
- Double-click the name of the WorkGroup for the printer.
- Double-click the Host Name of the printer.
- Click once on the Printer Name then click **OK**.

Windows 95/98, Windows NT 4.0 WorkStation and Windows 2000 Users

- Click the **Start** button and select **Settings**.
- From the cascade menu select **Printers**.
- Select a printer with the right mouse button.
- Select the **Properties** entry in the cascade menu.
- Select the **Details** tab on the Properties dialog.
- Click the **Add Port** button and browse to the Workgroup.
- Double click the name of the WorkGroup for the printer as shown on the Configuration Report. Double click the Host Name of the printer as shown on the Configuration Report.
- Click once on the Printer Name then click **OK**.
- Open an application and print a test page to verify operation.
- If your print job does not print, refer to the Troubleshooting section of this document to solve the problem.

9. Microsoft (TCP/IP) Networks

Before You Start

NOTE

Your Document Centre now has DHCP, LPR, and NetBIOS over the IP protocol enabled by default. If you have a DHCP server and it is set to provide host name, IP address, Gateway address, and Subnet Mask, the Document Centre TCP/IP information will be configured on initial boot.

To enable 100BaseT or a Token Ring interface, refer to Chapter 2 **How to Connect to Ethernet or Token Ring Networks** to configure the Speed and Source Routing settings for your environment.

For information on how your printer can connect to a BOOTP server, or a RARP server to be assigned an IP address dynamically, refer to the chapter in this document entitled **Dynamic/Static IP Addresses & WINS** Information in regards to static IP address configuration may be found within that section as well.

If you have not already assigned TCP/IP information...

The preceding sections assume that any IP address, subnet mask, gateway, or host name necessary for network installation has already been assigned to the Document Centre. If these components have not been configured, please refer to the section of this document entitled **Dynamic/Static IP Addresses & WINS** before continuing further:

For Dynamic Addressing - Section 3, pages 3-2 thru 3-5.

For Static Addressing - Section 3, pages 3-6 thru 3-8.

Once the printer has been configured to the appropriate TCP/IP settings, you may proceed to the next section.

Go to the Document Centre and...

NOTE

This procedure assumes that any TCP/IP components necessary for network installation have already been assigned to the Document Centre. If these components have not been configured, please refer to the appropriate information contained within the section entitled **Dynamic/Static IP Addresses & WINS** before continuing further.

Connect your Document Centre to the network with the appropriate cabling.

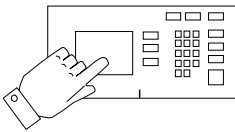

1. Enter the **Tools** pathway.
 - a) Press the **Access** (**A** or ) button.
 - b) On the keypad enter **1111** or the current password. Press the **Enter** button when finished. The Touch Screen will be used for the remainder of the data entry, unless instructed otherwise.
 - c) Press the **Go to Tools** button.
2. Enter the Network Setup menus.
 - a) Wait for the screen to refresh and press the **Connectivity and Network Setup** button.
 - b) Wait for the screen to refresh and press the **Network Setup** button.
3. Enable Microsoft Networking.
 - a) Press the **Microsoft Networks** button.
 - b) At the next screen, press the **Transport and Media** button.
 - c) Press the **Enable** button to enable the Microsoft Network protocols.
 - d) If Physical Media buttons appear, press the corresponding button to select either **IP/Ethernet**, or **IP/Token Ring**. After making your selection press **Save**.
 - e) Press the **Workgroup and Host** button.

- f) At the next screen, press the **Workgroup Name** button, using the touch panel keys. Enter the name of the workgroup in which you want the printer to appear then press **Save**.
 - g) Press the **SMB Host Name** (this will set the NetBIOS name) button, using the Touch Screen keys, enter the desired text then press **Save**.
 - h) **OPTIONAL STEP:** Press the **SMB Host Description** button and enter the desired text for this item, then press **Save**.
 - i) Press **Save** again to return to the Microsoft Networks screen.
 - j) Press the **Printer Description** button.
 - k) Press the **Printer Name** button, using the Touch Screen keys, enter the desired text for this item then press **Save**.
 - l) **OPTIONAL STEP:** Press the **Printer Description** button, using the touch panel keys and enter the desired text for this item, then press **Save**.
 - m) Press **Save** again to return to the Microsoft Networks screen.
 - n) Press the **Connections** button
 - o) Touch the **Maximum Connections** soft button on the Touch Screen and on the keypad enter the desired maximum connection number between 1 and 30. This number should be set to equal or greater than the number of workstations on your Peer to Peer network.
 - p) Touch the **Connection Timeout** soft button on the Touch Screen. On the keypad enter the desired number of seconds between 0 and 9999.
 - q) Press **Save** to exit the Connections Screen.
4. Exit the Tools Menu.
- a) Press the **Exit Tools** button. The printer will store the settings you have made.

5. Prepare for print driver installation.
 - a) From the documentation package supplied with your printer, retrieve the **CentreWare Network Services CD-ROM** and the document entitled **CentreWare Network Services Guide**. Proceed to the next section of this procedure called **Go to a Workstation and...**
6. Obtain a **Configuration Report** from the printer to use in the remainder of the installation.

Go to the workstation and...

NOTE

This procedure assumes that any TCP/IP components necessary for network installation have already been assigned to the Document Centre. If these components have not been configured, please refer to the appropriate information contained within the section entitled **Dynamic/Static IP Addresses & WINS** before continuing further.

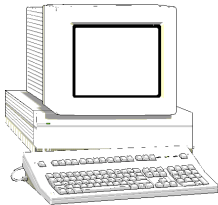

1. Verify that the TCP/IP protocol stack is loaded.
2. Use the **CentreWare Network Services CD-ROM** to install print drivers. Details for this are found in the document supplied with your printer entitled **CentreWare Network Services Guide**.

Windows 95/98, Windows NT 4.X Workstation and Windows 2000 Users

- Add a network printer as you normally would.
 - Browse for and Double-click the name of the **WorkGroup** for the printer as shown on the **Configuration Report**.
 - Double-click the **NetBIOS Host Name** of the printer as shown on the **Configuration Report**.
 - Click once on the **Printer Name** as shown on the **Configuration Report** then click **OK**.
 - For a new printer you will be prompted for a print driver. Select **Have Disk** and browse to the directory with the Document Centre driver, select it then click **OK**.
3. Open an application and print a test page to verify operation.
 4. If your print job does not print, refer to the Troubleshooting section of this document to solve the problem.
 5. Check your test job for quality and use the Problem Solving section of the **Document Centre Reference Guide** for resolving print defects.
 6. Repeat this **Go to the workstation and...** procedure for each workstation on the network that will print to the printer.

10. Windows 2000 LPR and IPP Printing

Before you Start

NOTE

Your Document Centre now has DHCP, LPR, and NetBIOS over the IP protocol enabled by default. If your DHCP server will provide host name, IP address, Gateway address, and Subnet Mask, the Document Centre TCP/IP information will be configured on initial boot. This means that if you have configured your DHCP server with the desired information, you may connect your Document Centre to your network and go right to the section entitled **Go to the Server/Workstation and....**

For information on how your printer can connect to a BOOTP server, or a RARP server to be assigned an IP address dynamically, refer to the chapter in this document entitled **Dynamic/Static IP Addresses & WINS**. Information in regards to static IP address configuration may be found within that section as well.

To enable 100BaseT or a Token Ring interface, refer to Chapter 2 **How to Connect to Ethernet or Token Ring Networks** to configure the Speed and Source Routing settings for your environment.

If you have not already assigned TCP/IP information...

The preceding sections assume that any IP address, subnet mask, gateway, or host name necessary for network installation has already been assigned to the Document Centre. If these components have not been configured, please refer to the section of this document entitled **Dynamic/Static IP Addresses & WINS** before continuing further:

For Dynamic Addressing - Section 3, pages 3-2 thru 3-5.

For Static Addressing - Section 3, pages 3-6 thru 3-8.

Once the printer has been configured to the appropriate TCP/IP settings, you may proceed to the next step.

Go to the Server/Workstation and...

NOTE

This procedure assumes that any TCP/IP components necessary for network installation have already been assigned to the Document Centre. If these components have not been configured, please refer to the appropriate information contained within the section entitled **Dynamic/Static IP Addresses & WINS** before continuing further.

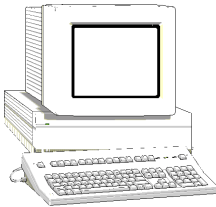

1. Verify the correct software is loaded.
 - a) At the Desktop, right mouse click the **My Network Places** icon and select **Properties**. Right mouse click on the **Local Area Connection** icon and verify that the **Internet Protocol (TCP/IP)** protocol has been loaded.
2. Add the printer.
 - a) Open **Control Panel** and double click the **Printers** icon.
 - b) Verify that **Network Printer** is selected and click **Next**.
 - c) The **Locate Your Printer** screen will appear.
 - d) Follow the steps to Create a LPR printer **OR** Create an IPP printer in the right column.

To create a LPR Printer

- a) Select **Local Printer**; deselect **Automatically detect and install my Plug and Play printer**. Click **Next**.
- b) Select **Create a new port** and choose **Standard TCP/IP port** from the pull-down menu. Click **Next** twice.
- c) Enter the **Printer Name** or its **IP address**. The Printer Name can be either the Host Name or the SMB Host Name as shown on the configuration report, depending on the name resolution used by your network (WINS or DNS). The **Port Name** is automatically filled in for you but you can change it if you want to. Click **Next**.

- d) The Wizard will automatically detect the Printer Model for you. If that does not happen select **Standard** and choose the your Printer Model from the pull-down menu.
- e) Click **Finish**. Go to Step 3.

To Create an IPP printer

- a) Select **Network Printer**. Click **Next**.
 - b) Select **Connect to a printer on the Internet or on your intranet**. Type **HTTP://** followed by the printer's fully qualified Domain name or IP address in the URL field. The Printer Name can be either the Host Name or the SMB Host Name as shown on the configuration report, depending on the name resolution used by your network (WINS or DNS). Click **Next**.
 - c) Click **OK** to install the printer driver. Go to Step 3.
3. Select the driver to be used (Document Centre 480/470/460 drivers are included on the Windows 2000 CD-ROM).
- a) A driver list will be displayed. Select Xerox from the **Manufacturers:** area. Then select the desired print driver from the **Printers:** and click **OK**. The driver will be installed.
 - b) The **Default Printer** window will open. Select **Yes** to make this the default printer, otherwise click the **Next>** button.
 - c) At the **Completing the Add Printer Wizard** screen, click the **Finish** button.
 - d) **Print a Test Page**. Verify that it prints. Repeat this **Go to the Server Workstation and...** procedure for each workstation on the network that will print to the printer.

11. Microsoft Windows NT 4.X Server Network (TCP/IP)

Before you Start

NOTE

Your Document Centre has DHCP enabled by default. If you have configured a DHCP server with TCP/IP information, you can connect your Document Centre to your network and it will retrieve its TCP/IP information from the DHCP server when it is turned on.

To enable 100BaseT or a Token Ring interface, refer to Chapter 2 **How to Connect to Ethernet or Token Ring Networks** to configure the Speed and Source Routing settings for your environment.

If you are using DHCP, perform **Steps 1 through 8b** contained within the *Dynamic Addressing* portion of the **Dynamic/Status IP Address Assignment & WINS** section but **DO NOT** change any values. Then read the note before step 9 and determine if you wish to change the lpr port number. After choosing, complete the remainder of the procedure.

If you have not already assigned TCP/IP information...

The preceding sections assume that any IP address, subnet mask, gateway, or host name necessary for network installation has already been assigned to the Document Centre. If these components have not been configured, please refer to the section of this document entitled **Dynamic/Static IP Addresses & WINS** before continuing further:

For Dynamic Addressing - Section 3, pages 3-2 thru 3-5.

For Static Addressing - Section 3, pages 3-6 thru 3-8.

Once the printer has been configured to the appropriate TCP/IP settings, you may proceed to the next section.

Go to the server and...

NOTE

This procedure assumes that any TCP/IP components necessary for network installation have already been assigned to the Document Centre. If these components have not been configured, please refer to the appropriate information contained within the section entitled **Dynamic/Static IP Addresses & WINS** before continuing further.

1. Verify the correct software is loaded.
 - a) At the Desktop, right mouse click the **Network Neighborhood** icon and select **Properties**. Click on the **Protocols** TAB and verify that the **TCP/IP** protocol has been loaded.
 - b) Select the **Services TAB** and verify that **Microsoft TCP/IP Printing** is loaded. If this software is not present, install it using the documentation provided by Microsoft. Then return to the next step in this document.
2. Add the printer.
 - a) Open the **Control Panel** and double-click **Printers** icon. Double-click **Add Printer**. The Add printer Wizard starts.
 - b) Verify that **My Computer** is selected and click **Next>**.
 - c) Click **Add Port**. From the list that appears select **LPR Port**. Click **New Port**.
 - d) This will open up the **Add LPR compatible printer** window. Type in the IP address of the Document Centre printer and the printer name and select **OK**. Note that the printer name is case sensitive.
 - e) The Wizard will return you to the previous dialog. Verify the new IP address you entered is in the list and correct.
 - f) The check box to the left of the address must be checked; if it is not, check it then select **Next>**.

- g) Insert **CentreWare Networks Services CD-ROM** and click **Have Disk**.
 - h) Click the **Browse** button and select the directory containing the Windows NT drivers. Details for this are contained in the document entitled **Network Services Guide**. Select the **PRINTER.INF** file then click **Open**.
 - i) The Wizard will return you to the previous dialog. Verify the path and file name are correct and click **OK**.
 - j) At the next dialog, enter a name for the printer and select whether you want that printer to be the default then click **Next>**.
 - k) If the printer will not be shared, click **Next>**. To share the printer, check the **share** checkbox, enter a Share Name, then click **Next>**.
 - l) At the next dialog it is recommended that you print a test page. Click **Finish**.
 - m) Wait for the Test Print to print. A new dialog will ask for confirmation of the test print; if the page printed, click **Yes**. If it did not print, run the Printing Troubleshooter in NT.
3. Send a test job to the printer.
- a) Check your test job for quality and use the problem solving section of the **Document Centre Reference Guide** for resolving print defects.
 - b) If your print job does not print, refer to the Troubleshooting section in this document to correct the problem.

Go to the workstation and...

NOTE

This procedure assumes that any TCP/IP components necessary for network installation have already been assigned to the Document Centre. If these components have not been configured, please refer to the appropriate information contained within the section entitled **Dynamic/Static IP Addresses & WINS** before continuing further.

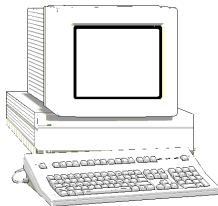

1. Verify that the TCP/IP protocol stack is loaded.
2. Use the **CentreWare Network Services CD-ROM** to install print drivers. Details for this are found in the document supplied with your printer entitled **CentreWare Network Services Guide**.
3. Connect the printer that you just created to the shared resource on the server.
4. Open an application on the workstation and print a test page to verify operation.
5. Check your test job for quality and use the problem solving section of the **Document Centre 490/480/470/460 Reference Guide** for resolving print defects.
6. Repeat this **Go to the workstation and...** procedure for each workstation on the network that will print to the printer.

12. OS/2 (TCP/IP) Networks

Before You Start

To enable 100BaseT or a Token Ring interface, refer to Chapter 2 **How to Connect to Ethernet or Token Ring Networks** to configure the Speed and Source Routing settings for your environment.

NOTE

Your Document Centre now has DHCP, LPR, and NetBIOS over the IP protocol enabled by default. If your DHCP server will provide host name, IP address, Gateway address, and Subnet Mask, the Document Centre TCP/IP information will be configured on initial boot. This means that if you have configured your DHCP server with the desired information, you may go right to the heading in this section entitled **Go to a Workstation and...**

For information on how your printer can connect to a BOOTP server, or a RARP server to be assigned an IP address dynamically, refer to the section in this document entitled **Dynamic/Static IP Addresses & WINS**. Information in regards to static IP address configuration may be found within that section as well.

If you have not already assigned TCP/IP information...

☞ The preceding sections assume that any IP address, subnet mask, gateway, or host name necessary for network installation has already been assigned to the Document Centre. If these components have not been configured, please refer to the section of this document entitled **Dynamic/Static IP Addresses & WINS** before continuing further:

For Dynamic Addressing - Section 3, pages 3-2 thru 3-5.

For Static Addressing - Section 3, pages 3-6 thru 3-8.

Once the printer has been configured to the appropriate TCP/IP settings, you may proceed to the next step.

Go to a workstation and...

NOTE

This procedure assumes that any TCP/IP components necessary for network installation have already been assigned to the Document Centre. If these components have not been configured, please refer to the appropriate information contained within the section entitled **Dynamic/Static IP Addresses & WINS** before continuing further.

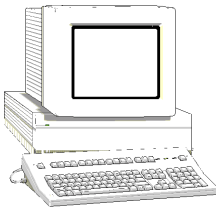

1. Create a new printer and load print drivers from the CD-ROM.
2. Create a printer share and its access permissions (sharing and connecting).
3. Start **LPRPORTD/LPRMON**, ping printer, open EPM and send a print job to the printer.
4. Check your test job for quality and use the problem solving section of the **Document Centre Reference Guide** for resolving print defects.
5. If your print job does not print, refer to the Troubleshooting section in this document to correct the problem.
6. Repeat this **Go to a workstation and...** procedure at each workstation that will print to this printer.

13. OS/2 (NetBEUI) Networks

Before You Start

To enable 100BaseT or a Token Ring interface, refer to Chapter 2 **How to Connect to Ethernet or Token Ring Networks** to configure the Speed and Source Routing settings for your environment.

Go to the Document Centre and...

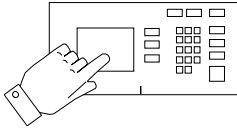

1. Connect your Document Centre to the network with the appropriate cabling.
2. Enter the **Tools** pathway.
 - a) Press the **Access** (**A** or ) button.
 - b) On the keypad enter **1111** or the current password. Press the **Enter** button when finished. The Touch Screen will be used for the remainder of the data entry, unless instructed otherwise.
 - c) Press the **Go to Tools** button.
3. Enable Microsoft Network printing.
 - a) Wait for the screen to refresh and press the **Connectivity and Network Setup** button.
 - b) Wait for the screen to refresh and press the **Network Setup** button.
4. Enable the Protocol and Media.
 - a) At the next screen, press the **Microsoft Networks** button.
 - b) At the next screen, press the **Transport and Media** button.
 - c) At the next screen, press the **Enable** button to enable the Microsoft Network protocols.
 - d) If Physical Media buttons appear, press the corresponding button to select either **NetBEUI/Ethernet** or **NetBEUI/Token Ring**. Press **Save**.

5. Assign the Workgroup and Host names.
 - a) You will be returned to the previous screen; press the **Workgroup and Host** button.
 - b) At the next screen, press the **Workgroup Name** button. Using the touch panel keys, enter the name of the workgroup in which you want the printer to appear, then press **Save**.
 - c) You will be returned to the previous screen. Press the **SMB Host Name** button, using the touch panel keys and enter the desired text for this item, then press **Save**.
 - d) **OPTIONAL STEP:** Press the **SMB Host Description** button, enter the desired text then press **Save**. You will be returned to the previous screen.
 - e) Press **Save** again to return to the previous screen.
6. Assign a Printer Name and Description.
 - a) Press the **Printer Description** button.
 - b) Press the **Printer Name** button. Using the touch panel keys, enter the desired text for this item then press **Save**. Press **Save** again to return to the previous screen.
 - c) **OPTIONAL STEP:** Press the **Printer Description** button, using the touch panel keys, enter the desired text for this item then press **Save**.
 - d) Press the **Connections** button.

- e) Set Maximum Connections and Timeout.
 - f) Touch the **Maximum Connections** soft button on the touch screen and on the keypad enter the desired maximum connection number between 1 and 30. It is recommended that this value should be set at the default.
 - g) Touch the **Connection Timeout** soft button on the Touch Screen. On the keypad enter the desired number of seconds between 0 and 9999. Press **Save** to exit the connections screen.
7. Exit the Tools Menu.
- a) Press the **Exit Tools** button. The printer will store the settings you have made.
8. Prepare for print driver installation.
- a) From the documentation package supplied with your printer, retrieve the **CentreWare Network Services CD-ROM** and the document entitled **CentreWare Network Services Guide**. Proceed to the next section of this procedure called **Go to a Workstation and...**

Go to the workstations and...

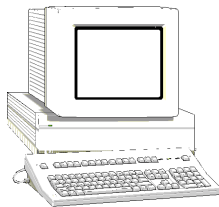

1. Perform an OS2 Warp (4.0) **Selective Install**.
 - a) Install Both **NetBIOS (NetBEUI)** and **NetBIOS for IP** during the install process.
 - b) Select and Enable all of the file and print sharing options during the **Selective Install** process.
2. Create a shared resource and connect it to the network device.
 - a) Double-click on the **Connections** Icon.
 - b) Click on the + symbol next to **Network**.
 - c) Click on the + symbol next to **Network Services**.
 - d) Double-click on **Start File and Print Client**.
 - e) Close the **Logons** window.
 - f) Double Click on **Shared Resources and Network Connections**.
 - g) Close the **Connections** Window.
 - h) Enter a valid user/password (the one entered at the client installation).
 - i) Select the **Connections** tab of these property pages.
 - j) Select the **Create connection** button.
 - k) Set the resource type to **Printer**.

- l) Enter the machine's hostname in the **Server** field
- m) Select the desired lpt port.
- n) Verify that the **Connect to resource at logon** button is selected.
- o) Place the cursor in the server field and press the **Enter** key on the keyboard.
- p) Click the **OK** button after the share name appears in the **Resource** window.
- q) Close the **Shared Resources and Network Connections - Properties** window.
- r) Double-click on the **Connections** Icon.
- s) Double-click on **Printers**.
- t) Close the **Connections** window.
- u) Double-click on **Printer** in the Printers window. **DO NOT CHOOSE THE NETWORK PRINTER OPTION.**
- v) Enter a name for the local queue in the **Printer** window. (Overwrite the printer that already appears with something unique - this does not have to be the share or hostname of the printer)
- w) Make sure the cursor is still in the printer window and press the **Enter** key on the keyboard.
- x) Select **familiar w/ OS/2** if prompted.
- y) Highlight the correct lpt port (assigned in step **2m**).

3. Install a new printer driver.
 - a) Insert CentreWare CD into your CD-ROM drive.
 - b) Make a /desktop/drivers directory from an OS/2 Window.
 - c) Copy the driver files from the CD-ROM disk to the /desktop/drivers directory.
 - d) Click the **Install new printer driver...** button.
 - e) Select **Other OS/2 printer driver**.
 - f) Enter the correct directory in the appropriate field.
 - g) Click the **Refresh** button.
 - h) Click the **Install** button after you see the driver description appear.
 - i) Click the **OK** button to confirm that the driver has been installed.
4. Highlight the OS/2 driver in the **Default printer driver** window and click the **Create** button.
5. Close the **Printers** window.
6. You are now ready to print to the local queue created in step **2v**.
7. Print a test job.
8. Check your test job for quality and use the problem solving section of the **Document Centre Reference Guide** for resolving print defects.
9. If your print job does not print, refer to the Troubleshooting section in this document to correct the problem.

14. Macintosh Networks (AppleTalk)

Before you start

To enable 100BaseT or a Token Ring interface, refer to Chapter 2 **How to Connect to Ethernet or Token Ring Networks** to configure the Speed and Source Routing settings for your environment.

This procedure assumes you have Macintosh computers equipped with an Ethernet card or Token Ring card that is connected to the network and you are currently printing using the AppleTalk protocol.

As part of the procedure in this section you will need to know the following information, the AppleTalk Name you wish to assign to your printer, and the AppleTalk Zone (if used) in which your printer will reside.

Go to the Document Centre and...

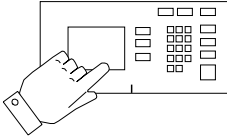

1. Connect your Document Centre to the network with the appropriate cabling.
2. Access the **Tools** pathway.
 - a) Press the **Access** (**A** or ) button.
 - b) On the keypad enter **1111** or the current password. Press the **Enter** button when finished. The Touch Screen will be used for the remainder of the data entry, unless instructed otherwise.
 - c) Press the **Go to Tools** button.
3. Enable the AppleTalk protocol.
 - a) Wait for the screen to refresh and press the **Connectivity and Network Setup** button.
 - b) Wait for the screen to refresh and press the **Network Setup** button.
 - c) Press the **AppleTalk** button.
 - d) Press the **Protocol and Media** button.
 - e) Press the **Enable** button. If Physical Media buttons appear, select either **Ethernet** or **Token Ring**. Press **Save**.

4. Assign a Name and Zone to your printer.
 - a) You will be returned to the previous screen. Press the **AppleTalk Settings** button.
 - b) At the next screen, press the **Printer Name** button, enter the name you want for the printer (this is the name that will appear in the Chooser on your workstations) using the touch panel keys.
 - c) Press the **Zone Name** button, enter the desired text for this item using the touch panel keys (the printer default is * which means the printer will appear in ALL zones). When finished press the **Save** button twice to record the changes.
5. Exit the Tools Menu.
 - a) Press the **Exit Tools** button. The printer will store the settings you have made.
6. Print a **Configuration Report** page from your printer to use in the remainder of the installation.
 - a) Repeat Steps 2a and 2b.
 - b) Select **System Setting**.
 - c) Select **Configuration Report**.
 - d) Select **Print Configuration Report Now**.
 - e) Select **Cancel**.
7. Prepare for print driver installation.
 - a) Review the **AppleTalk Settings:** area of the **Configuration Report** page and verify that **AppleTalk** is enabled, the **AppleTalk Name** is correct, the **AppleTalk Zone** is correct (if used).
 - b) From the documentation package supplied with your printer, retrieve the **CentreWare Network Services CD-ROM** and the document entitled **CentreWare Network Services Guide**. Proceed to the next section of this procedure called **Go to a Workstation and...**

Go to the workstation and...

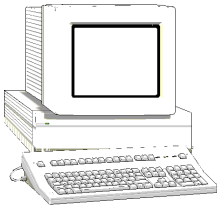



1. Use the **CentreWare Network Services CD-ROM** to install print drivers and the Macintosh **PUtility** on the workstation. Details for this are found in the document supplied with your printer entitled **CentreWare Network Services Guide**
2. Send a test job to the printer from an application programme.
3. Check your test job for quality and use the Problem Solving section of the **Document Centre Reference Guide** for resolving print defects.
4. If your job did not print see the Troubleshooting section in this document to correct the problem.

15. Banyan VINES Network

To enable 100BaseT or a Token Ring interface, refer to Chapter 2 **How to Connect to Ethernet or Token Ring Networks** to configure the Speed and Source Routing settings for your environment.

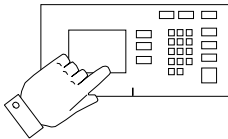
Go to the Document Centre and...



1. Connect your Document Centre to the network with the appropriate cabling.
2. Enter the **Tools** pathway.
 - a) Press the **Access** (**A** or ) button.
 - b) On the keypad enter **1111** or the current password. Press the **Enter** button when finished. The Touch Screen will be used for the remainder of the data entry, unless instructed otherwise.
 - c) Press the **Go to Tools** button.

3. Enable Banyan VINES printing.
 - a) Wait for the screen to refresh and press the **Connectivity and Network Setup** button.
 - b) Wait for the screen to refresh and press the **Network Setup** button.
 - c) Press the **Banyan VINES** button.
 - d) Press the **Protocol** button.
 - e) Press the **Enable** button to start the Banyan Vines protocol and press **Save**.
4. Configure User Name settings and Password.
 - a) At the next screen, press the **Settings** button.
 - b) At the next screen, press the **User Name/PC Print Destination** button, enter the desired text for this item using the touch panel keys, then press **Save**.
 - c) Press the **User Password** button. Enter the desired text for this item using the touch panel keys, then press **Save**.
 - d) Press the **Print Service Name** button. Enter the desired text for this item using the touch panel keys. When finished press the **Save** button twice to record the changes.
5. Exit the Tools Menu.
 - a) Press the **Exit Tools** button. The printer will store the settings you have made.
6. Print a **Configuration Report** page from your printer to use in the remainder of the installation.
 - a) Repeat Steps 2a and 2c.
 - b) Select **System Setting**.
 - c) Select **Configuration Report**.
 - d) Select **Print Configuration Report Now**.
 - e) Select **Cancel**.

7. Prepare for print driver installation.
 - a) Check the **Configuration Report** page and verify that **Banyan VINES** is enabled and the other Banyan Settings are correct.
 - b) From the documentation package supplied with your printer, retrieve the **CentreWare Network Services CD-ROM** and the document entitled **CentreWare Network Services Guide**. Proceed to the next section of this procedure called **Go to the server and...**

Go to the server and...

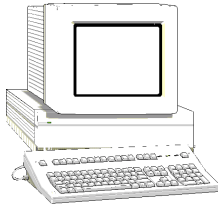

1. Configure the Service and Queue
 - a) Using the **MUSER** utility, create a user name and assign a password for the printer. The user name and password must be the same that were entered at the Document Centre.
 - b) Using the **MSERVICE** utility, highlight and select **ADD a server-based service**.
 - c) At the **Add A Service** Screen, enter the **StreetTalk name** and **description** when prompted.
 - d) Select the server on which you want to create the service.
 - e) Select **Banyan Print Service**.
 - f) Select an appropriate disk location when prompted.
 - g) A message will be displayed stating that the service is running, but is not yet available to users.
 - h) Press the **F10** key to continue.
 - i) The **Configure Queue** Screen will be displayed.
 - j) Press the **F10** key to accept the defaults.
2. Configure the Paper Formats
 - a) The **Configure Paper Formats** Screen will be displayed.
 - b) Press the **Escape** key to continue without making any changes.

3. Configure Access Lists and Print Destination.
 - a) The **Access Lists** screen will be displayed.
 - b) Press the **F10** key to accept the defaults.
 - c) The **Add a Destination** screen will be displayed.
 - d) Select **PCPrint** and press **Enter**.
 - e) From the **Destination Attributes** Screen, enter the Document Centre user name as the PCPRINT ST name and Description, and then press the **F10** key.

NOTE

The PCPrint ST name must be the same as the user name created and must also match the Street Talk (user) Name entered at the printer.

- f) The **Output Strings** Screen will be displayed. Press the **F10** key to accept the defaults displayed on the screen.
 - g) The **Enable Strings** Screen will be displayed. Press the **F10** key to accept the defaults displayed on the screen.
 - h) Select **No** and press **Enter** when you are prompted to add another destination.
4. Enable the Print Queue.
 - a) The **Print Queue Status** Screen will be displayed.
 - b) Change the **Printing jobs** and the **Accepting jobs** fields to **Yes** and then press the **F10** key.
 - c) A message will be displayed stating that the printer is ready to accept and print jobs. Press the **F10** key to continue.
 - d) The **Manage A Service** screen will be displayed.
 - e) Press the **Escape** Key to return to the **Manage Services** main menu.
5. Power off and power on the Document Centre for these setup options to take effect.

16. Internet Services

Overview

With the scan or fax options installed, you may also use Internet Services to create, modify and delete scan or fax templates.

With Internet Services and a web browser users can print or scan documents using the Document Centre and System Administrators can:

- enable users to print and scan without installing any client software
- integrate into other web-based printer management tools
- remotely configure and manage Xerox Printers
- monitor printer and consumable status
- easily access Xerox support home pages and customer-definable hotlinks

Easy Setup

Administrators will enjoy the convenience of being able to define printer settings and network connections from any workstation with a web browser. When installing several printers on the network, the programme's clone feature provides a quick shortcut to duplicating the settings from one printer to another.

Simplified Navigation

There's no need to remember where a particular feature is located within CentreWare Internet Services. Simply use the Table of Contents or Device Index pages to locate the desired function. This link will quickly navigate to the appropriate pages.

Remote Configuration and Management

System administrators can remotely configure, monitor and manage printers on local and wide area networks. At the click of a button, administrators have access to such information as printer configuration and performance data. Multi-tiered password security is provided for each printer configuration.

Printer and Consumable Status

CentreWare Internet Services allows the administrator to perform up-to-the-minute status checks to keep Xerox printers fully operational. Administrators can monitor the status of toner and other consumables on Xerox printers.

Remote Diagnostics and Troubleshooting

The accessibility of printer and network information provides administrators with the means to remotely detect network printing problems quickly and accurately. By minimizing printer downtime, administrators will improve workgroup satisfaction with network printing.

Hotlinks to Customer Support

Hotlinks are provided for easy access to Xerox product information, software updates, and support resources. Administrators can also specify web sites for use when additional support assistance is needed.

Who should read this chapter

This chapter is designed for Network Administrators and general users of Internet Services. Network Administrators should use the guide to gain an understanding of Internet Services software and to perform many Document Centre set up and management tasks over the Internet. General users can use the guide to perform tasks that do not require configuration access or administrative rights.

How to Get Help

HTML (HyperText Markup Language) Help is provided with Internet Services. You can access this online help by clicking the *Help* button in the bottom frame of the browser window and navigating the directory within Internet Services. HTML Help includes descriptions of all of the features and options within Internet Services.

Before You Start

Your Document Centre device and workstation(s) must be connected to a network which has the TCP/IP protocol enabled.

This procedure assumes you have a general knowledge of your network type and the operation of your Web Browser software, and that your Document Centre printer has been assigned all TCP/IP information.

Configure your printer

NOTE

To use Internet Services on the Document Centre 490/480/470/460 ST, this feature must be enabled. The procedure below is supplied to enable this feature or disable it if you do not wish to use Internet Services.

1. Connect your Document Centre to the network with the appropriate cabling.
2. Go to the Document Centre control panel.
3. Enter the **Tools** pathway.
 - a) Press the **Access** (**A** or ) button.
 - b) On the keypad enter **1111** or the current password. Press the **Enter** button when finished. The Touch Screen will be used for the remainder of the data entry, unless instructed otherwise.
 - c) Press the **Go to Tools** button.
4. Enable the Network Protocol.
 - a) Wait for the screen to refresh and press the **Connectivity and Network Setup** button.

- b) Wait for the screen to refresh and press the **Network Setup** button.
5. Press the **TCP/IP Options** button.
6. Press the **HTTP/IPP** button. Then press either the **Enable** or **Disable** button as desired.
7. Press the **Exit Tools** button.

Browser Configuration

Supported Environments and Web Browsers for the Document Centre 490/480/470/460 ST.

The table below lists the web browsers that can be used to monitor a Document Centre 490/480/470/460 ST in the supported operating system environments.

Operating Environment	Netscape 4.0X	Netscape 4.5X thru 4.7X	Internet Explorer 4.X	Internet Explorer 5.X
Microsoft Windows 95/98	Y	Y	Y	Y
Microsoft Windows NT 4.0	Y	Y	Y	Y
Microsoft Windows 2000	Y	Y	Y	Y
Macintosh System 8.6	Y	Y	N	N
Mac OS 9.0	Y	Y	N	N
Solaris 2.5/2.6 (SunOS 5.5/5.6)	Y	Y	Y	Y
Solaris 7 (SunOS 5.7)	Y	Y	Y	Y
Solaris 8 (SunOS 5.8)	Y	Y	N	Supported with patch available from Microsoft Web Site

While Xerox is testing other browsers which are beta releases for compatibility with Document Centre Internet Services, to ensure that you can perform all the functions contained in Internet Services, it is recommended you use one of the browsers shown in the table above.

Enable Java Script in your Web Browser

If you are using Netscape Navigator or Internet Explorer, ensure that Java script is enabled.

Refer to the documentation or online help for your browser to perform this function.

Enable Refresh in the Browser

Refresh clears files in your cache each time you enter a new web page.

For optimum performance using Internet Services, set your browser to refresh each time you access a web page.

Refer to the documentation or online help for your browser to perform this function.

Internet Services Interface Features

When you enter Internet Services, you access the Document Centre Home Page, which is the starting point for the application. From the Home Page, you access other pages in the application.

Document Centre Home Page

To access Internet Services, perform the following procedure:

1. Type in the IP address of the Document Centre in your browser's Address or Location field. For example, <http://10.12.123.234>. The Document Centre's Home Page appears, which displays the links to other pages.
2. To go to other pages, click an icon or a link to access the desired page.

The screenshot shows the 'Document Centre' home page. At the top left is the 'CentreWare Internet Services' logo. The main heading is 'Document Centre'. On the left is an image of a printer. To the right of the printer image, there are two paragraphs of text describing the products. Below the printer image, there are fields for 'Name: Test', 'Location: Lab', 'IP Address: XXX.XXX.XXX.XXX', and 'Status: Idle'. Below these fields is a 'Refresh Status' button. On the right side of the page, there is a vertical menu of links: 'Services' (submit print ready jobs and program distribution templates), 'Jobs' (view and delete jobs in print queue), 'Status' (current device configuration), 'Properties' (view and set device parameters), 'Maintenance' (font list and test page), and 'Support' (local contacts and Xerox contacts). At the bottom left is 'THE DOCUMENT COMPANY XEROX' and at the bottom right is 'Copyright © Xerox Corporation 1997-2000. All rights reserved.' and a 'help' link.

CentreWare
Internet Services

Document Centre

Document Centre products combine world class printing, copying, scanning & faxing for walk-up, network and web-based users. The products are scalable and modular by design to grow as your business needs grow.

The Document Centre products offer a broad array of digital features including concurrent processing of printing, copying, scanning & faxing, benchmark image quality up to 1800 d.p.i., duplex, and single & dual stapling.

Name: Test
Location: Lab
IP Address: XXX.XXX.XXX.XXX
Status: Idle

Services
submit print ready jobs and program distribution templates

Jobs
view and delete jobs in print queue

Status
current device configuration

Properties
view and set device parameters

Maintenance
font list and test page

Support
local contacts and Xerox contacts

Index

THE DOCUMENT COMPANY
XEROX

Copyright © Xerox Corporation 1997-2000. All rights reserved.

help

Pages and Frames

From within Internet Services, each main page has a tab. Clicking the tab displays the desired page. Other sub pages are available from within each tab.

Some Internet Services pages are divided into a left and right frame. The left frame will contain status information or links that will display new information about the Document Centre to which you are connected. The width of the left and right frames can be adjusted by sliding the divider between the two frames. On some pages, information in the left frame is shown in tree or directory/folder format. Clicking the plus (+) sign will expand the tree, while clicking the minus sign (-) collapses the tree.

As an example the Services Page is shown below.

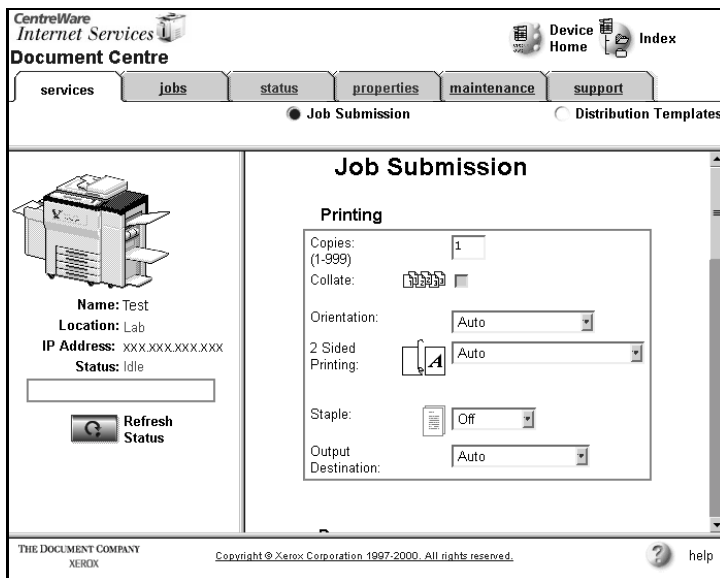

Page Buttons

The table below lists the common buttons that are available on the Internet Services pages and frames.

Button Name	Action performed when selected
Apply	Write and Save modifications to the Distribution Template.
Browse	Access network or local directory paths.
Default Settings	Restores the SNMP Community Names to their default values.
Delete Job	Cancel or delete a print job from the Document Centre print queue.
Device Home	Access the Home Page of the Document Centre to which you are connected.
Device Index	Access Internet Services index and contents for the Document Centre pages.
Help	Access Internet Services HTML Help system.
Index	Access Internet Services index and contents for the Document Centre pages.
Print Test Page	Print a test page on the default paper size, type, and color (Note that accounting information may be necessary).
Font Listing	Display a listing of available fonts.
Refresh Alerts	Update the Alerts Page with the latest alert information.
Refresh Counters	Update usage counters with current values.
Refresh Jobs	Update the Jobs Page with new job listings.
Refresh Status	Update the page with the latest device status information.
Restore	Return the settings to their previous settings in the Distribution Template.
Restore Default Values	Return the settings to their default values.
Restore Settings	Return the settings to their last saved values.
Submit Job	Submits a job for processing.

For details, see the section entitled “**Accessing the Document Centre Properties**” later in this chapter.

Administration Logon

The Network administrator factory default username and password for the embedded HTTP server is listed in the following table. It is the same logon that is required for access at the Document Centre. This logon is needed when modifying Document Centre properties using Internet Services. For details on modifying Properties see the section entitled Accessing the Document Centre Properties.

Embedded HTTP Server Administrator Logon	
Administrator Username	admin
Administrator Password	1111

It is recommended that you change this password after the initial logon to prevent unauthorized access to the HTTP server.

How to change the Administrator Password.

1. Go to the Document Centre control panel.
2. Enter the **Tools** pathway.
 - a) Press the **Access** (**A** or ) button.
 - b) On the keypad enter **1111** or the current password. Press the **Enter** button when finished. The Touch Screen will be used for the remainder of the data entry, unless instructed otherwise.
 - c) Press the **Go to Tools** button.
3. Press the **Access and Accounting** button.
4. Press the **Tools Mode Access** button.
5. At the next screen, press the **User Number** field. When the background of this field turns black, use the numbers on the keypad to enter a new number. Record this number and keep in a safe place.
6. Press the **Close** button. Then press **Exit Tools**. Re-enter the Tools menu to validate the change has taken effect.

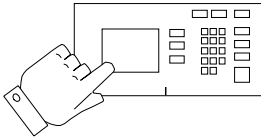

Internet Services Use

This section of the Internet Services chapter explains how to perform tasks using the Services pages for printing and scanning documents over the Internet/intranet. Delayed, Proof, and Secure printing options are also provided. You can scan documents at the Document Centre using Distribution Templates, which are set up using the Services Pages. Documents can be scanned to File or Fax, simply by using a template and scanning the document.

Print Documents with Job Submission on the Services Page

Print-ready documents can be quickly and easily submitted for printing using the Services Page. A print-ready document is a file that has been formatted and saved for printing from the application that created it or was printed to file by a printer driver. Keep in mind that large print jobs need adequate space on your hard drive when printing.

NOTE

Selecting print and/or finishing options from the Services Page will override, but not reformat, existing PostScript or PCL print-ready documents.

The following file formats can be printed from the Services page:

- **PCL**
- **PostScript**
- **TIFF (Tagged Image File Format)**
- **ASCII Text**
- **PDF (Portable Document Format) Document Centre 490/480 ONLY**

NOTE

ASCII text files, from systems other than PCs, may not print correctly if hard carriage returns (ASCII Control-M) are not used as line delimiters in the text.

How To Print from your Web Browser

To submit a document to print:

1. To access Internet Services open your Web Browser and enter the TCP/IP address (or fully qualified domain name) in the Address or Location field and press Enter.
2. Your Browser will display the Document Centre Home Page.
3. Click the **Services** button or link from the Document Centre Home Page.

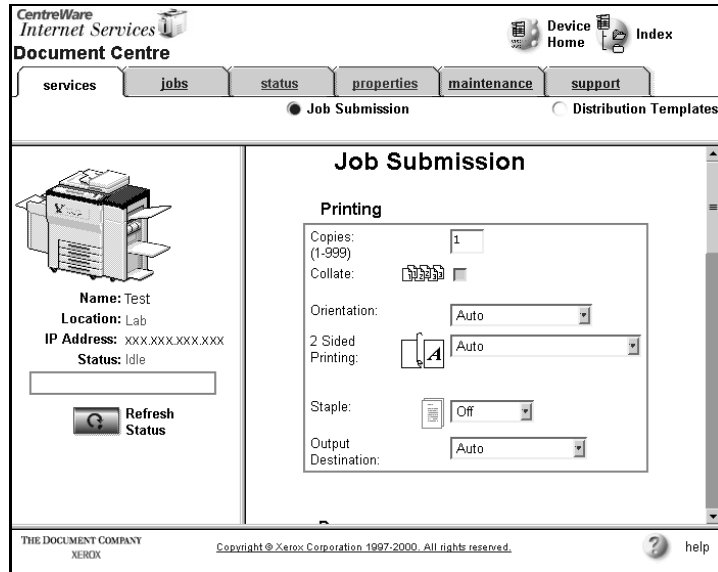

4. The graphic above shows the top of the Services Page which enables printing.
5. Select the **Job Submission** radio button at the top of the page just below the tabs.

6. In the **Printing** section of the screen, select options according to your job requirements:
 - Type in the number of copies needed.
 - Select other options, such as two sided printing, orientation, stapling, or output destination for your job from the drop-down lists.
 - Paper options, such as tray, size, media type, and color.
 - Type an Account and User ID for accounting.

NOTE

The Accounting fields are only visible if accounting is enabled on your Document Centre.

Types of Printing

Immediate	Prints as soon as the Submit Job button is pressed.
Proof	Prints one set of multiple copies to allow for review. After review, you may release the remaining sets for printing or delete the job to make changes.
Delayed	Set the hour and minute and select AM or PM to print a job at the specified time.
Secure	Enter a password (four digit number) to enter at the Document Centre keypad for documents that need to be kept secure.

7. In the **Delivery** area of the screen, select the desired type of printing. See the table above for a description of each.
8. In the File Name text entry box at the bottom of the screen, type the path and file name or click the **Browse** button to locate the print-ready file to process.
9. When finished with your selections, click **Submit Job** to process your job. Click OK if prompted. Wait for Job Submission screen to reappear before exiting so your print job will not be deleted.

Releasing a Secure Print Job at the Document Centre

1. Go to the Document Centre control panel and press the **Job Status** pathway button.
2. Find your document on the list of All Incomplete Jobs. Press the name until it highlights, which selects the job.
3. On the screen that appears, press **Delete** to delete the job or press **Release** to release the job for printing.
4. The touch screen will display a password prompt.
5. With the keypad, enter the four digit code you used when you submitted the job from your Web Browser then, on the touch screen press the **Enter** button.
6. Your job will print.

Releasing a Proof Print Job at the Document Centre

1. Go to the Document Centre and retrieve the first copy of your job. Review the copy to be sure it printed as desired.
2. At the control panel press the **Job Status** pathway button.
3. Find your document on the list of All Incomplete Jobs. Press the name until it highlights, which selects the job.
4. On the screen that appears, press **Delete** to delete the job if it is not printed as desired or press **Release** to release the job for printing.
5. The Document Centre will print the number of copies of your job that you selected in the Web Browser.

Scanning Documents

NOTE

The ability to scan documents with the Document Centre device is an optional feature. If your Document Centre does not have the scan option installed, you do not need to read this section of the chapter.

This Scanning Documents section explains how to use and create templates for scanning documents at the Document Centre. You can scan a document with specific scan parameters that you select using Internet Services, or use the settings provided from a default template.

The first step is to choose an existing template or create one for scanning using the Distribution Templates pages. Once the template is set up, go to the Document Centre, update the template list and choose the template, then scan the document. Documents are scanned to a Tagged Image File Format (TIFF) or Portable Document (PDF).

Scanning Functionality

Internet Services provides the following scanning capabilities that you can perform:

- Scan to File (folder) — scan a document and store the electronic version in a specific document directory on a network file server.
- Scan to Fax (folder)— scan a document and fax to specified recipient(s).

NOTE

Faxing on the Document Centre 490/480/470/460 ST is only available with an external faxing hardware and software solution.

Distribution Templates

Distribution templates control the manner in which a scanned document is processed. They contain specific instructions that define the electronic document's format and details about how to file, fax, store or distribute a scanned document. A default distribution template is provided for Internet Services.

Distribution templates created with Internet Services are stored on the Document Centre device. A Template Pool is a directory location on a server.

Templates can be created once and used repeatedly. For example, you may want to create a template with settings that you consistently use when scanning documents. Then, each time you scan, you can select the template and not have to change the settings.

To access Distribution Templates:

1. Access Internet Services.
2. Click the **Services** tab or click **Services** from the Document Centre Home Page.
3. Select **Distribution Templates**.

NOTE

If Distribution Templates is not selectable, Scanning is not enabled on the Document Centre or repositories have not been defined.

The list of available templates appears in the Distribution Template directory tree.

Template Management

Distribution templates can be created, modified, or deleted using Internet Services. You can create a brand new template for your own use, or modify an existing template.

If you want to...	Do this...
Create a new template with customized settings for personal use	<ol style="list-style-type: none">1. Access the Services Page and access Distribution Templates.2. Create a new template and customize the template settings.3. Apply the settings.
OR	<ol style="list-style-type: none">4. Save the template.
Create a template for multiple use	<ol style="list-style-type: none">5. Update the template list at the Document Centre.6. Select the template at the Document Centre.7. Scan the document at the Document Centre.
Select a template for one time use	<ol style="list-style-type: none">1. Go to the Document Centre.2. Select a template (or the default template) at the Document Centre.3. Scan the document at the Document Centre.
Scan a document to file	<ol style="list-style-type: none">1. Access the Services Page and access Distribution Templates.2. Create a new distribution template with a directory (folder) location as a filing destination. You could use the default scan to file template.3. Update the template list at the Document Centre.4. Select the scan to file template at the Document Centre.5. Scan the document at the Document Centre.6. Access the directory (folder) to view the location of the scanned file.

If you want to...**Do this...**

Scan a document
and fax

1. Access the Services Page and access Distribution Templates.
 2. Create a new distribution template with Fax as a filing destination (Fax folder) and select faxing delivery and recipient options.
 3. Apply the settings.
 4. Update the template list at the Document Centre.
 5. Select the fax template at the Document Centre.
 6. Scan the document at the Document Centre. The RightFax software detects the document in the Fax folder and automatically faxes the document to the recipient(s) specified in the template.
-

Distribution Templates

This procedure creates a new template with settings from the default distribution template.

To create a new template:

1. Open your Web browser and enter the TCP/IP address of the Document Centre in the Address or Location field. Click **Services** from the Document Centre Home Page.
2. At the top of the screen, select the **Distribution Templates**.
3. Click the **New** button at the top left corner of the Services tab.

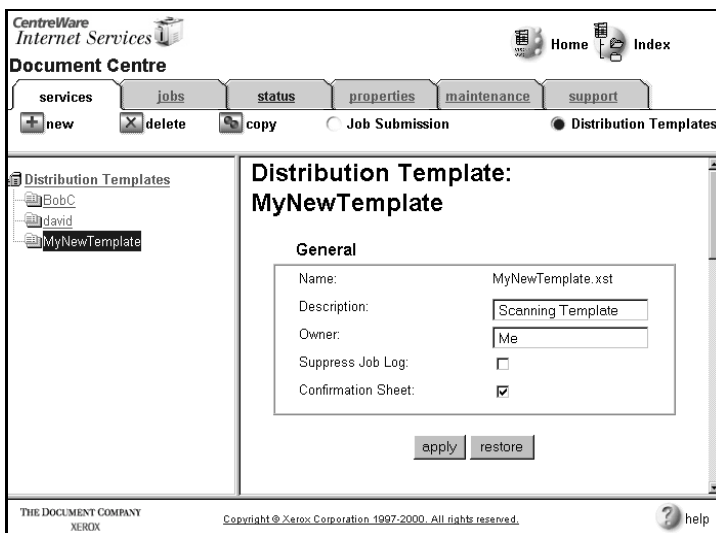

4. Type a name and description for the template.
5. Click the **Apply** button. The template is created and is added to the Distribution Template tree. This template will have all the default properties. To change these settings read the next section entitled **Template Settings**.

Template Settings

Templates can automatically control characteristics such as:

- **scan destination (document folder, Fax folder)**
- **scanned document output format (TIFF, Multi-page TIFF, and PDF)**
- **image settings (resolution, contrast, etc.)**
- **fax sending options (send time, recipients)**
- **document management (fields for name, label, default values)**

These characteristics are settings that you can specify in Internet Services, including: General (template description), Scan Settings (scan options), Distribution (storage and destination options), and Document Management Fields. These options are described in the following sections.

General Settings

Contains the template name, template description, template owner name, suppress job log, and confirmation sheet settings.

To modify the General settings:

NOTE

Template names can not be changed. You must delete the old template and create a new one with the new name.

1. Type a new description or owner name.
2. Select the appropriate checkbox to suppress the job log or print a confirmation sheet.

NOTE

Suppress Job Log cannot be selected if the template is for faxing.

3. Click **Apply**.
4. To return to the previously saved settings, click **Restore**.

Scan Settings

Scan settings are the scan processing characteristics used when scanning with Internet Services. Use the scroll bars to view all the settings.

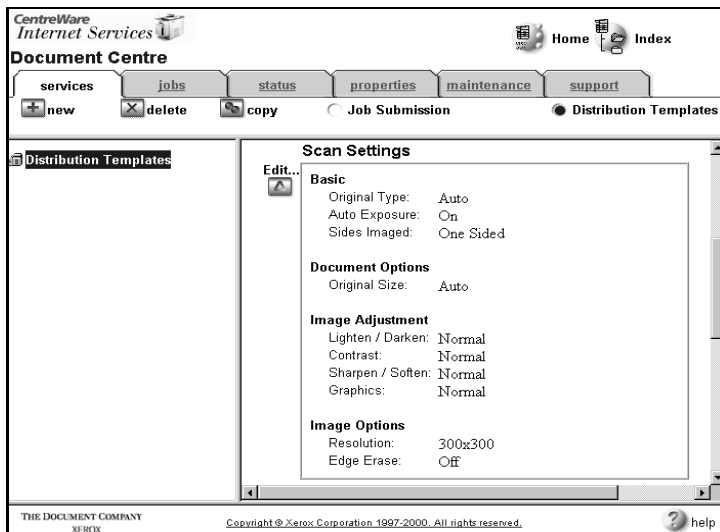

To edit scan settings:

1. Click the **Edit** button next to Scan Settings. Depending on screen resolution and Browser window sizing you may need to scroll down.
2. Review the table on the next page that shows setting names and a description of the feature, then make the desired selections to the image and size settings.
3. When finished, click the **Apply New Settings** button.

The following table shows the available scan settings that can be defined in a template and a description of each.

Category	Setting	Description
Basic	Original Type	<p>Auto (default) automatically detects the type of original.</p> <p>Text indicates that the original is text or line art.</p> <p>Photo indicates that the original is a photograph.</p>
	Auto Exposure	<p>Used for enhancing documents with colored backgrounds by adjusting for different types of images.</p> <p>On (checkbox selected) selects an appropriate exposure level for the original document.</p> <p>Off (checkbox deselected) uses the Lighten/Darken setting for the exposure level.</p>
	Sides Imaged	Print the image on one side or two sides of the paper.
Document Options	Original Size	<p>Selects the page dimensions of the scanned image to match the original size.</p> <p>Normal specifies a standard size (Letter or A4).</p> <p>Pre-set specifies a pre-defined size.</p> <p>Custom specifies a size that you set.</p> <p>Auto varies dimensions of the scanned image to match the original size automatically.</p>
Image Adjustment	Lighten/Darken	Lightens or darkens the brightness of the printed image.
	Contrast	Adjusts the clarity (difference in gray shades) of the printed image. Increased contrast makes the image more defined in black and white. Decreased contrast makes the image more defined in gray tones.
	Sharpen/Soften	Softens or makes the edges of the printed image more pronounced.
	Graphics	<p>Normal sets the continuous-tone reproduction to 106 dpi screens.</p> <p>Emulate DocuTech allows Xerox DocuTech users to set the continuous-tone reproduction to emulate the DocuTech at a lower 85 dpi screen setting.</p>

Category	Setting	Description
Image Options	Resolution	Prints the image in a selected number of dots per inch (dpi). A higher dpi, such as 600 x 600, produces a higher quality image, but creates a larger file size.
	Edge Erase	Erases the left/right/top/bottom margins of the document.

Distribution Settings

Filing Destination

Filing destinations are the defined scan repositories. Scanned documents are scanned to public folders or directories. A **Public Folder** is a repository location that is usually a file server directory that is defined and configured by a network administrator specifically for scanned documents. You can also scan to a fax repository. For more information see the section entitled **Distribute to Fax** (in this chapter).

To edit a filing destination:

1. Select a destination path from the **Destinations** list.
2. Click the **Edit** button.

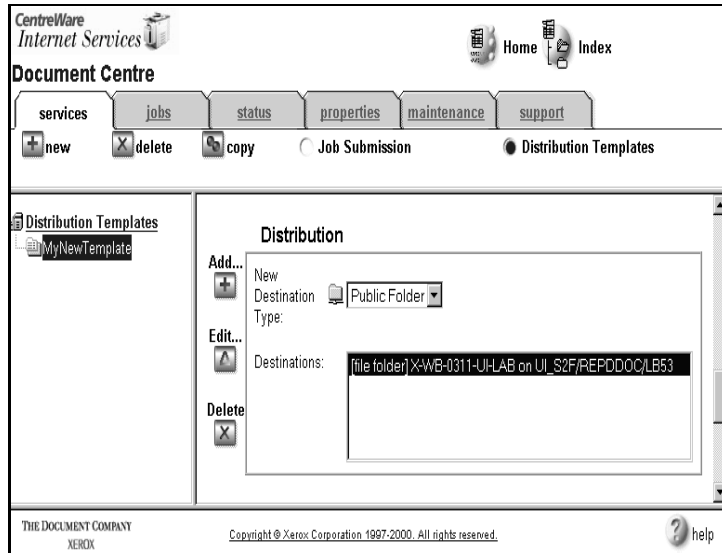

3. On the screen that appears, make the desired changes to the destination repository, path, filing policy, document name, or output format.
4. Click the **Apply New Settings** button.

To delete a filing destination:

1. Select the defined destination path.
2. Click the **Delete** button.

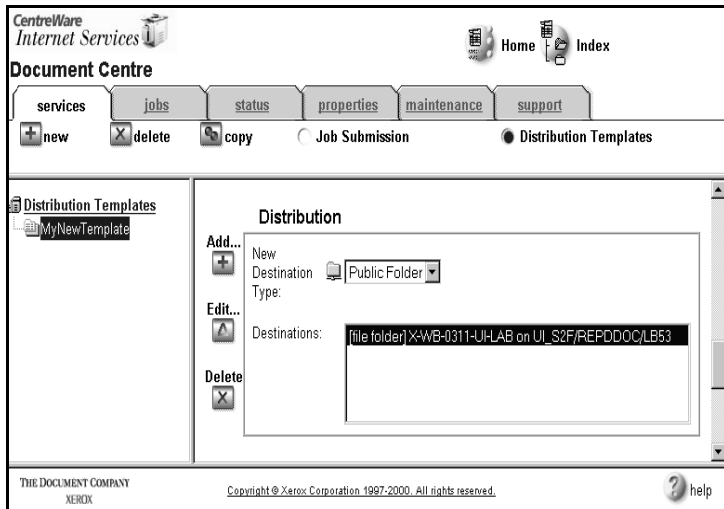

3. The template will be removed from the Distribution Templates tree.

To define a new destination:

1. Use the drop list menu to select the type of destination (Public Internet Folder or Fax if your device is so equipped), then click the **Add** button.

The screenshot shows the 'Document Centre' web interface. At the top, there are navigation links for 'Home' and 'Index'. Below that is a menu with 'services', 'jobs', 'status', 'properties', 'maintenance', and 'support'. A secondary menu contains 'new', 'delete', 'copy', 'Job Submission', and 'Distribution Templates'. The main content area is titled 'Distribution Templates' and contains a 'MyNewTemplate' entry. The 'Filing Destination' configuration form includes the following fields and options:

- Select from Repository: [Dropdown menu]
- Servers: [Text input]
- Path to Document: [Text input]
- Document Name: [Text input with 'DOC']
- File Format:
 - TIFF
 - Multi-Page TIFF
 - PDF
- If Document Already Exists:
 - Rename New File
 - Append to Existing File
 - Overwrite Existing File
 - Do Not Save

An 'Apply New Settings' button is located at the bottom of the form. The footer contains 'THE DOCUMENT COMPANY XEROX', 'Copyright © Xerox Corporation 1997-2000. All rights reserved.', and a 'help' icon.

2. Refer to the table on the next page for settings information then, specify a new destination repository, path, filing policy, document name, or output image format based on how you want your document to be filed and rendered.
3. Click the **Apply New Settings** button.

Distribute to File

Category	Setting	Description
Filing Destination	Select from Repository Servers	Internet Service's ability to automatically send scanned images to File (folder) or Fax (folder).
	Path to Document	Directory path for the scanned document.
	Document Name	Name of the scanned document.
	File Format	<p>Tagged Image File Format (TIFF) of the scanned output file.</p> <p>TIFF indicates that each page of the document is stored in a separate image file.</p> <p>Multi-Page TIFF indicates that all pages of a document are stored in a single file.</p> <p>PDF indicates the document pages will be stored as images in a Portable Document Format file. This mode does not support text-searchable PDF documents.</p>
	If Document Already Exists	<p>Append to Existing File adds the new file to the previously scanned folder in the specified repository.</p> <p>Overwrite Existing File overwrites the folder and file that were previously scanned with the new folder and file.</p> <p>Do Not Save matches the document name for the folder specified in the template.</p> <p>Rename New File generates an alphanumeric name for the folder based on the document name specified in the template. The folder names increment when more documents are scanned. You can scan up to 999 times with a template using Rename New File. After that number, an error sheet is generated by the Document Centre.</p>

Distribute to Fax

If you have an external fax hardware or software solution installed, you can also scan to a Fax folder. When you scan to a Fax folder, your fax solution software detects the Fax file in the repository and sends the fax to the specified recipient(s). You can access the fax settings for modification by clicking **Edit**.

To edit fax information:

1. Select a Fax destination and click **Edit** (under Destinations).
2. Refer to the table below and select the delivery options.
3. Enter the desired recipient information.
4. Click the **Apply New Settings** button.

Category	Setting	Description
Fax	Delivery	Immediate sends the fax immediately. Delayed Send sends the fax at the Hour/Minute and AM/PM specified.
Recipients		
	Enter Phone Number	Type the phone number and click the button with the green arrow to add the number to the list. Click the button with the red X to remove the number from the list.

Document Management

If you have document management software installed, you can assign attributes to index, sort, and retrieve your documents.

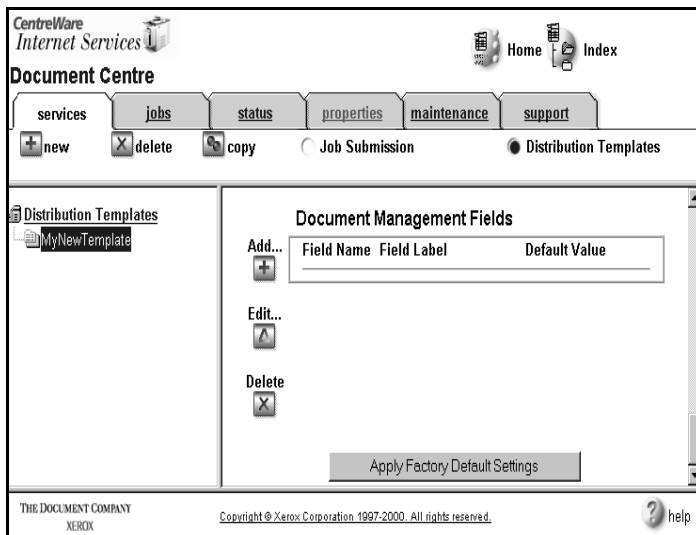

1. Select **Add** or **Edit** to add or modify the field attributes which will satisfy the requirements of your document management software.
2. On the screen that appears, make any desired addition or change to the Document Management Field.
3. If the Field Name is user editable, enter a Field Label to identify the purpose of the field to the user.
4. If the Field Name is not user editable, enter the Default Value.
5. Click on **Add New Field** to store changes or **Restore Settings** to return the settings to their previous values.

Deleting Distribution Templates

This procedure removes a template from the Document Centre.

To Delete a template:

1. Open your Web browser and enter the TCP/IP address of the Document Centre in the Address or Location field. Click **Services** from the Document Centre Home Page.
2. At the top of the screen, select the **Distribution Templates**.
3. Select a template from the tree.
4. Click the **Delete** button at the top left corner of the Services tab.

The template is deleted and removed from the Distribution Template tree.

NOTE

The default template cannot be deleted.

Copying Distribution Templates

This procedure creates an exact copy of the selected template.

To copy a template:

1. Open your Web browser and enter the TCP/IP address of the Document Centre in the Address or Location field. Click **Services** from the Document Centre Home Page.
2. At the top of the screen, select the **Distribution Templates**.
3. Select a template from the tree.
4. Click **Copy**. The new copy of the template appears.
5. Type a new name for the template.
6. Click **Apply**.

Updating the Template List at the Document Centre

After a template is created or deleted, the template list on the Document Centre must be updated to display the new template or to remove the deleted template. Internet Services templates are listed at the top of the list and are preceded with an @ symbol.

To update the template list:

1. Go to the Document Centre control panel/touch screen and press **Features**.
2. Press **All Services** then press **Network Scanning**.
3. On the Touch Screen, select **Update Template List**.

The template list is refreshed and any newly created or updated templates are visible. For complete information about the Document Centre control panel/touch screen, see the additional administrative documentation that came with your Document Centre.

Manage Jobs with Internet Services

This section explains how to perform tasks using the Jobs page. You can view all print and scan jobs that are processed by the Document Centre. Job name, owner, type, and number of copies are displayed on the page. If permissions allow, and jobs have not yet processed, you can delete these print and scan jobs using the Jobs page.

Displays on the page all print and scan job information in the Document Centre job queue and provides features which allow users to view and control jobs. Jobs that are processed from Internet Services are named *webclient* in the Owner column.

Viewing the Active Jobs List

1. Open your Web browser and enter the TCP/IP address of the Document Centre in the Address or Location field.
2. Click the **Jobs** tab or click **Jobs** in the directory tree. The Active Jobs Page appears, which contains job information. The screen displays the job name, the owner of the job, job status, the type of job, and the number of copies requested.
3. Click **Refresh Jobs** to update job list and status information.

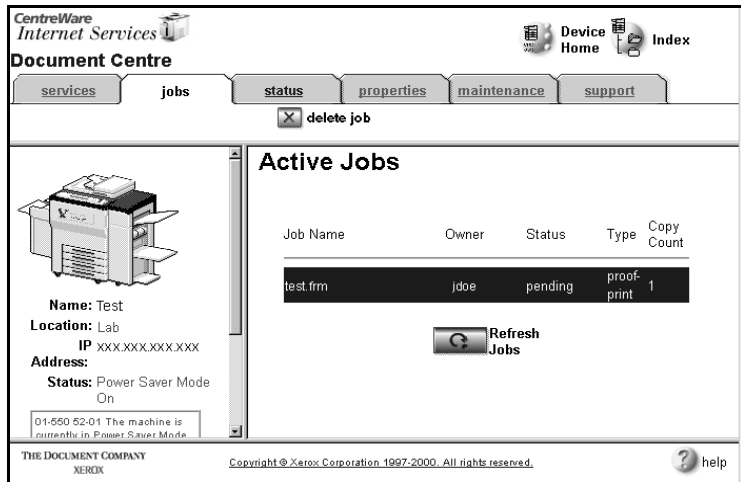

CentreWare
Internet Services

Document Centre

services jobs status properties maintenance support

delete job

Active Jobs

Job Name	Owner	Status	Type	Copy Count
test.frm	jdoe	pending	proof print	1

Refresh Jobs

Name: Test
Location: Lab
IP XXX.XXX.XXX.XXX
Address:
Status: Power Saver Mode On
01-550 52-01 The machine is currently in Power Saver Mode

THE DOCUMENT COMPANY
XEROX

Copyright © Xerox Corporation 1997-2000. All rights reserved.

help

Deleting Jobs

To delete job(s) from the jobs list:

1. Open your Web browser and enter the TCP/IP address of the Document Centre in the Address or Location field.
2. Click the **Jobs** tab or click **Jobs** in the directory tree. The Active Jobs information displays.
3. Highlight the job that you want to delete.
4. Click **Delete Job**. The job is removed from the jobs list.
5. A dialog box appears. Click **OK** to proceed with the deletion.
6. To see that the job has been removed from the jobs list, click **Refresh Jobs** to update the list.

NOTE

If a job is printing or has already printed, a dialog appears stating that the job(s) cannot be deleted.

View Document Centre Status with Internet Services

This section explains how to check the Document Centre 490/480/470/460 ST status using the Status pages. The status of the device, such as a paper jam or ready to print, appears on the page. You can also check to see if the paper trays are loaded or need reloading. Any alert messages can be viewed to provide more details on any fault or problem with the Document Centre.

The Document Centre's general device, alert message, and tray status can be displayed using Internet Services. You can also restart the machine from the General Status Page.

Viewing General Status

Displays general information, such as whether the printer is operational.

To view printer status:

1. Open your Web browser and enter the TCP/IP address of the Document Centre in the Address or Location field.
2. Click the **Status** tab or click **Status** in the directory tree.
3. You may review status information at this screen.
4. If you suspect that the status of the device has changed, click the **Refresh Status** button to reload status information from the device.

Viewing Active Alert Messages

Displays detailed information about a fault or problem. The status code of the alert is also displayed for reference if Xerox customer support is needed.

To view alert messages:

1. Open your Web browser and enter the TCP/IP address of the Document Centre in the Address or Location field.
2. Click the **Status** tab or click **Status** in the directory tree.
3. Click **Alerts**. Any active alert messages and status code are displayed on the page.

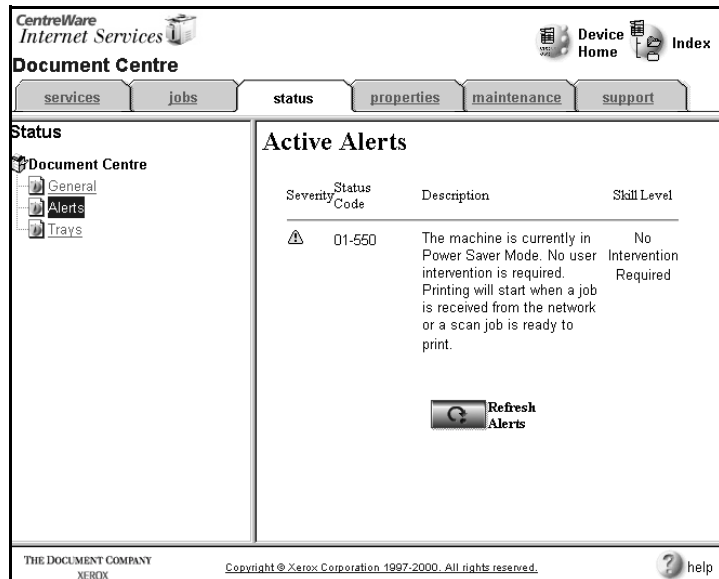

The screenshot shows the Xerox Document Centre web interface. At the top, there is a navigation bar with tabs for 'services', 'jobs', 'status', 'properties', 'maintenance', and 'support'. The 'status' tab is selected. On the left, a directory tree shows 'Document Centre' with sub-items 'General', 'Alerts', and 'Trays'. The 'Alerts' item is selected. The main content area is titled 'Active Alerts' and contains a table with the following data:

Severity	Status Code	Description	Skill Level
⚠	01-550	The machine is currently in Power Saver Mode. No user intervention is required. Printing will start when a job is received from the network or a scan job is ready to print.	No Intervention Required

Below the table is a 'Refresh Alerts' button with a circular arrow icon. At the bottom of the page, there is a footer with 'THE DOCUMENT COMPANY XEROX' on the left, 'Copyright © Xerox Corporation 1997-2000. All rights reserved.' in the center, and a 'help' icon on the right.

4. Click **Refresh Alerts** to update the page with current alert information.

Viewing Tray Status

To view paper supply and output tray status:

1. Open your Web browser and enter the TCP/IP address of the Document Centre in the Address or Location field.
2. Click the **Status** tab or click **Status** in the directory tree.
3. Click **Trays**. The paper supply, including the paper's tray, status, size, color, and type are displayed on the page. Output tray status, including the installed paper tray and its status, also appears.

The screenshot shows the CentreWare Internet Services web interface. At the top, there is a navigation bar with tabs for 'services', 'jobs', 'status', 'properties', 'maintenance', and 'support'. The 'status' tab is selected. On the left, a directory tree shows 'Document Centre' with sub-items 'General', 'Alerts', and 'Trays'. The 'Trays' item is selected. The main content area is titled 'Trays' and contains a 'Paper Supply' table and an 'Output Destinations' section.

Paper Tray	Status	Size	Color	Type
Tray 1	Ready	8.5 x 11"	Letter	White Punched
Tray 2	Ready	8.5 x 14"	Legal	White Plain Paper
Tray 3	Ready	11 x 17"		White Plain Paper
Tray 4	Ready	8.5 x 11"	Letter	White Plain Paper
Tray 5 (Bypass)	Ready	8.5 x 11"	Letter	clear Transparency
Tray 6 (High Capacity)	Ready	8.5 x 11"	Letter	White Plain Paper

Below the table is an 'Output Destinations' section with a table that has two columns: 'Paper Tray' and 'Status'.

4. Click **Refresh Tray Status** to update the page with the latest tray status information.

View Document Centre Properties with Internet Services

This section explains how to perform tasks using the Properties Pages. The Properties Pages of Internet Services contain vital information concerning the Document Centre's printer, print job, connectivity, HTTP settings, services, and distribution templates settings. You can remotely view and set configuration and options from your browser.

Internet Services supports the Internet Printing Protocol (IPP). See the administrative documentation that accompanied your Document Centre for more information.

Accessing the Document Centre Properties

Properties are the default parameters or settings that control the Document Centre and how it operates. General users can view the settings contained within the Properties Page, but only Network Administrators can modify them. The Network Administrator's username and password is required the first time settings are applied in the Properties Page during a browser session.

NOTE

You must possess Network Administrator (Admin) rights for the embedded HTTP server and have knowledge of your Document Centre's configuration to perform the modification tasks explained in this chapter.

1. Open your Web browser and enter the TCP/IP address of the Document Centre in the Address or Location field.
2. Click the **Properties** tab or click **Properties** in the directory tree.

Description

Description contains information that identifies a specific Document Centre model, name, and physical location.

To set identification for the Document Centre:

1. Click the **Properties** tab or click **Properties** in the directory tree.
2. Select **Description** in the directory tree.
3. Type the name of the Document Centre in **Machine Name**.
4. Type the site location for the Document Centre in **Location**.
5. Click **Apply New Settings** to accept the changes or **Restore Settings** to return the settings to their previous values

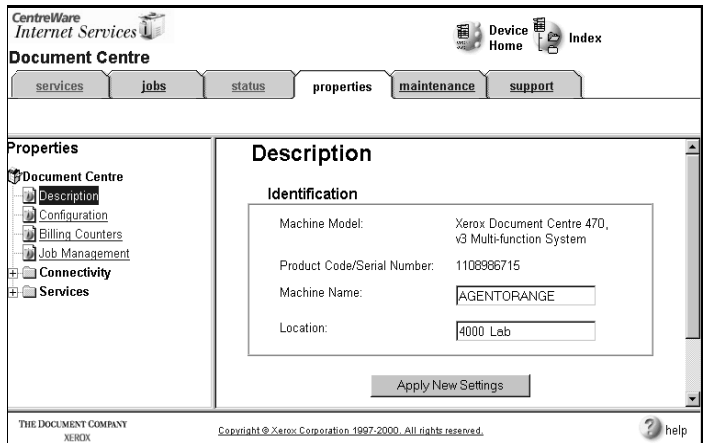

Configuration

Configuration contains information about the software and printer language versions that are installed on your Document Centre. Included are PCL, PostScript, and TIFF printer languages version numbers, and the User Interface, Network Controller, and Printer software versions. The information is read only.

To view Document Centre configuration information:

1. Open your Web browser and enter the TCP/IP address of the Document Centre in the Address or Location field.
2. Click the **Properties** tab or select **Properties** in the directory tree.
3. Select **Configuration** in the directory tree.

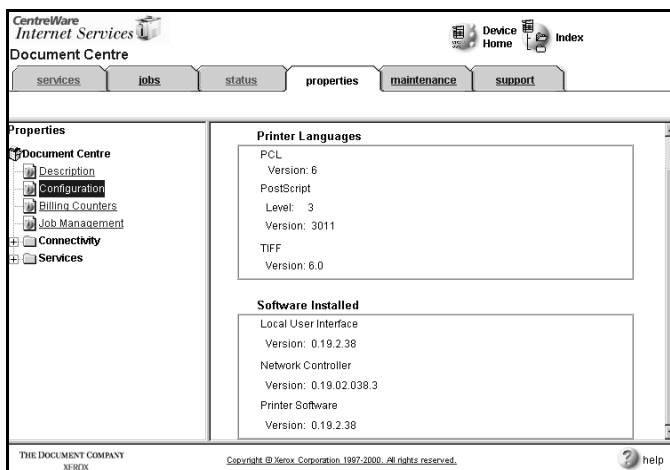

Billing Counters

Billing Counters contains information about the number of images produced (copied or printed) by the Document Centre. This information can be used for billing purposes. The different counters include the various types of copy and fax sheets and scanned imaged sheets used. Also included are marked sheets, which include banner sheets or Document Centre reports, such as configuration reports.

To view usage counters:

1. Open your Web browser and enter the TCP/IP address of the Document Centre in the Address or Location field.
2. Click the **Properties** tab or select **Properties** in the directory tree.
3. Select **Billing Counters** in the directory tree.
4. Click **Refresh Counters** to update the page with current amounts.

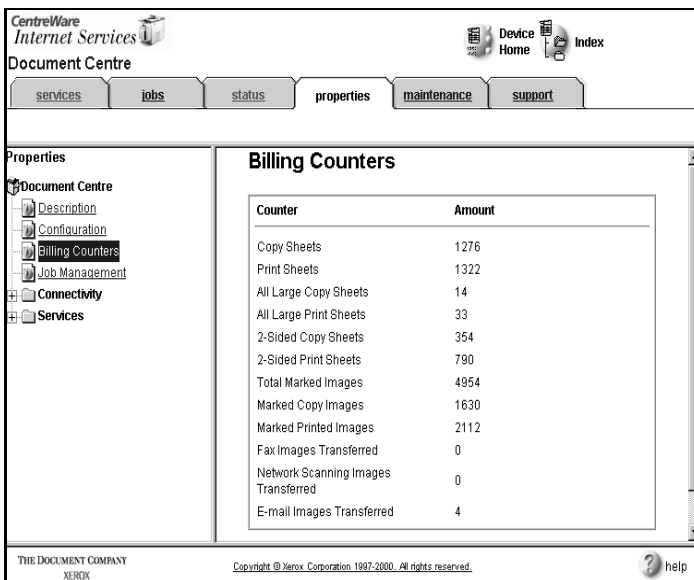

CentreWare
Internet Services

Document Centre

services jobs status **properties** maintenance support

Properties

- Document Centre
 - Description
 - Configuration
 - Billing Counters**
 - Job Management
- Connectivity
- Services

Billing Counters

Counter	Amount
Copy Sheets	1276
Print Sheets	1322
All Large Copy Sheets	14
All Large Print Sheets	33
2-Sided Copy Sheets	364
2-Sided Print Sheets	790
Total Marked Images	4954
Marked Copy Images	1630
Marked Printed Images	2112
Fax Images Transferred	0
Network Scanning Images Transferred	0
E-mail Images Transferred	4

THE DOCUMENT COMPANY
XEROX

Copyright © Xerox Corporation 1997-2000. All rights reserved.

help

Job Management

Job Management allows you to set permission that allows Network Administrators or general (non-administrator) users to delete jobs from the Document Centre print queue.

NOTE

Network Administrators can always delete any job, regardless of the setting selected on the Job Management Page.

To set job deletion permission

1. Open your Web browser and enter the TCP/IP address of the Document Centre in the Address or Location field.
2. Click the **Properties** tab or select **Properties** in the directory tree.
3. Select **Job Management** in the directory tree.

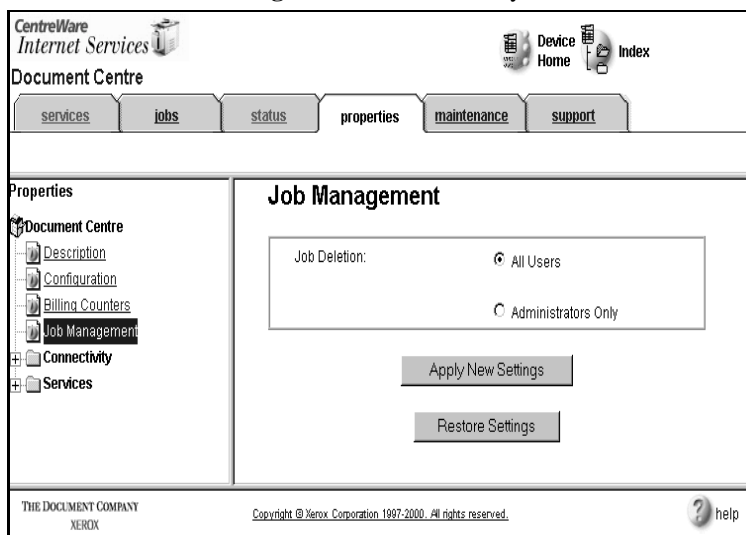

4. Select **All Users** to allow any user to delete their own or any other job OR select **Administrators Only** to allow only users with administrative access (password) to delete jobs.
5. Click **Apply New Settings** to accept the changes or **Restore Settings** to return the settings to their previous values.

This Connectivity section shows the available options for connecting your Document Centre to your network. Connectivity allows you to view and modify network connections and protocols using your browser and Internet Services GUI. For complete information on installing and setting up your Document Centre, see the additional administrative documentation that came with your Document Centre.

Physical Connections

Physical connections are the hardware and cabling that attach Document Centres to a network. You can configure Ethernet, parallel port, or token ring options from the Physical Connection pages of Internet Services.

Ethernet

To set an Ethernet speed:

1. Open your Web browser and enter the TCP/IP address of the Document Centre in the Address or Location field.
2. Click the **Properties** tab or click **Properties** in the directory tree.
3. Select **Connectivity**, then select **Physical Connections** in the directory tree.

4. Select **Ethernet** in the directory tree.

The screenshot shows the Xerox Document Centre web interface. At the top, there is a navigation bar with 'Document Centre' and tabs for 'services', 'jobs', 'status', 'properties', 'maintenance', and 'support'. The 'properties' tab is active. On the left, a 'Properties' sidebar shows a tree view with categories like 'Document Centre', 'Connectivity', 'Physical Connections', 'Protocols', and 'Services'. Under 'Physical Connections', 'Ethernet' is selected. The main content area is titled 'Ethernet' and contains a 'Rated Speed' dropdown menu set to '10 Mbps' and a 'M.A.C. Address' field with the value '00:90:27:ed:1a:9e'. Below these fields are 'Save New Settings' and 'Restore Settings' buttons. A note states: 'Note: Settings will not be applied until the Machine has been rebooted from the Status Tab.' Another note says: 'Old settings will be displayed if this page is visited before the Machine has been rebooted.' The footer includes 'THE DOCUMENT COMPANY XEROX' and 'Copyright © Xerox Corporation 1997-2000. All rights reserved.' with a help icon.

5. Select the speed (Auto, 10 Mbps, or 100 Mbps) from the **Rated Speed** drop-down.
6. Click **Save New Settings** to accept the changes or **Restore Settings** to return the settings to their previous values.

NOTE

The settings are not applied until you restart the Document Centre.

Parallel Port

NOTE

If the parallel port is not in service, this page is unavailable.

To specify parallel port settings:

1. Open your Web browser and enter the TCP/IP address of the Document Centre in the Address or Location field.
2. Click the **Properties** tab or click **Properties** in the directory tree.
3. Select **Connectivity**, then select **Physical Connections** in the directory tree.
4. Select **Parallel** in the directory tree.

The screenshot shows the CentreWare Internet Services web interface. At the top, there is a navigation bar with tabs for 'services', 'jobs', 'status', 'properties', 'maintenance', and 'support'. The 'properties' tab is selected. On the left, a directory tree shows the following structure: Document Centre (expanded) with sub-items: Description, Configuration, Billing Counters, Job Management, Connectivity (expanded) with sub-items: Physical Connections (expanded) with sub-items: Ethernet, Parallel (selected), and Token Ring, Protocols, and Services. The main content area is titled 'Parallel' and contains the following settings:

- Connection: enabled
- Time-out: seconds

Below the settings are two buttons: 'Apply New Settings' and 'Restore Settings'. A note at the bottom of the settings area reads: 'Note: Settings will not be applied until the Machine has been rebooted from the Status Tab.' Another note below that reads: 'Old settings will be displayed if this page is visited before the Machine has been rebooted.'

At the bottom of the page, there is a footer with 'THE DOCUMENT COMPANY XEROX' on the left, 'Copyright © Xerox Corporation 1997-2000. All rights reserved.' in the center, and a help icon on the right.

5. Select **Connection Enabled** to enable the parallel port.
6. Type a Time-out in seconds. Valid entries are from 1-30 seconds.
7. Click **Apply New Settings** to accept the changes or **Restore Settings** to return the settings to their previous values.

NOTE

The settings are not applied until you restart the Document Centre.

Token Ring

NOTE

If the token ring network interface is not installed, this page is unavailable.

To specify token ring settings:

1. Open your Web browser and enter the TCP/IP address of the Document Centre in the Address or Location field.
2. Click the **Properties** tab or click **Properties** in the directory tree.
3. Select **Connectivity**, then select **Physical Connections** in the directory tree.
4. Select **Token Ring** in the directory tree.

5. Select the desired **Rated Speed** from the drop-down list, either 4 or 16 Mbps.
6. Type the machine address in **M.A.C. Address**.
7. Select None, All Broadcasts, or Single Routes Broadcasts from the **Source Routing** drop-down list.
8. Click **Save New Settings** to accept the changes or **Restore Settings** to return the settings to their previous values.

NOTE

If the token ring network interface is not installed, this page is unavailable.

Network Protocols

Network protocols are groups of software applications that support communication on the network. You can configure options for Appletalk, Banyan VINES, NetWare, TCP/IP, SNMP, Microsoft Networking, LPR/LPD, and Port 9100 Printing.

Appletalk

1. Open your Web browser and enter the TCP/IP address of the Document Centre in the Address or Location field.
2. Click the **Properties** tab or click **Properties** in the directory tree.
3. Select **Connectivity**, then select **Protocols** in the directory tree.
4. Select **Appletalk** in the directory tree.

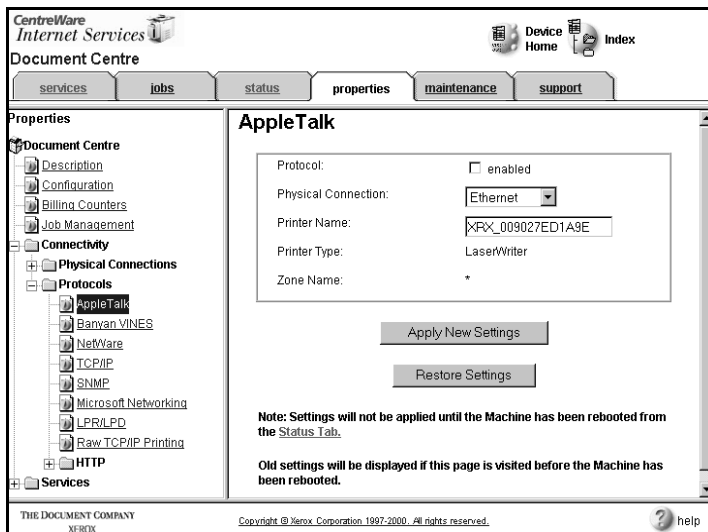

5. Select **Protocol Enabled** to enable Appletalk.

6. If your Document Centre has an enabled token ring card, select either Ethernet or Token Ring from the **Physical Connection** drop-down list.
7. Type a name (up to 32 characters) for the Document Centre in **Printer Name**.
8. Click **Apply New Settings** to accept the changes or **Restore Settings** to return the settings to their previous values.

NOTE

The settings are not applied until you restart the Document Centre.

Banyan VINES

1. Open your Web browser and enter the TCP/IP address of the Document Centre in the Address or Location field.
2. Click the **Properties** tab or click **Properties** in the directory tree.
3. Select **Connectivity**, then select **Protocols** in the directory tree.
4. Select **Banyan VINES** in the directory tree.

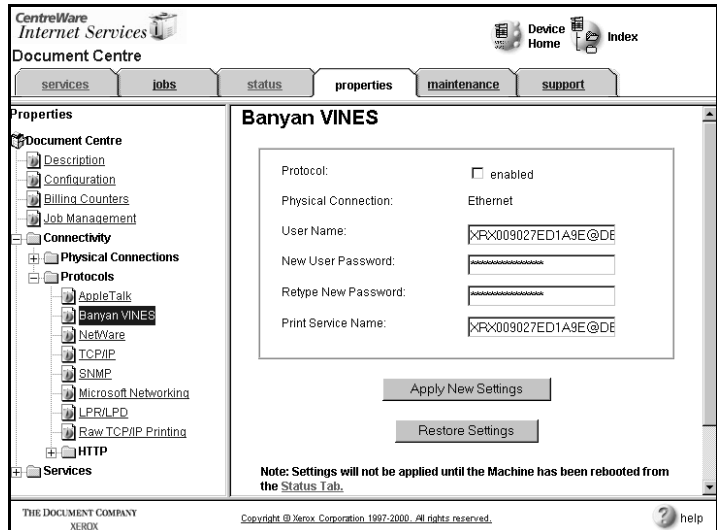

5. Select **Protocol Enabled** to enable Banyan VINES.
6. Type a PCPRINT user name in **User Name**.

7. Type a **New User Password** for the PCPRINT user name and then confirm this password by typing it again in **Retype Password**.
8. Type the Document Centre's StreetTalk name in **Print Service Name**.
9. Click **Apply New Settings** to accept the changes or **Restore Settings** to return the settings to their previous values.

NOTE

The settings are not applied until you restart the Document Centre.

NetWare

To specify NetWare settings:

1. Open your Web browser and enter the TCP/IP address of the Document Centre in the Address or Location field.
2. Click the **Properties** tab or click **Properties** in the directory tree.
3. Select **Connectivity**, then select **Protocols** in the directory tree.
4. Select **NetWare** in the directory tree.

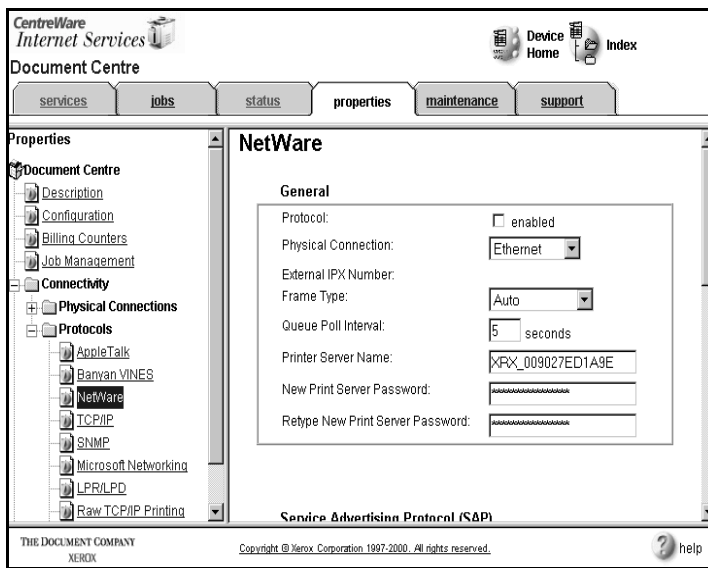

5. Select **Protocol Enabled** to enable NetWare.
6. If your Document Centre has an enabled token ring card, select either Ethernet or Token Ring from the **Physical Connection** drop-down list.
 - Select an Ethernet or Token Ring **Frame Type** from the drop-down list.
7. Type a polling rate for the print server (1 - 65536 seconds) in **Queue Poll Interval**.

8. Type the **Print Server Name**.
9. Type a **New Print Server Password** for the print server and then type it again to confirm in **Retype Password**.
10. Select **Protocol Enabled** to enable SAP (Service Advertising Protocol).
11. Type the **SAP Frequency** (from 15 -300 seconds or enter 0 for none).
12. For NetWare Bindery, type the names of up to four primary **File Servers** for the Document Centre.
13. For NetWare NDS (NetWare Directory Services), type a directory tree and context for the Document Centre in **NDS Tree** and **NDS Context**.
14. Click **Apply New Settings** to accept the changes or **Restore Settings** to return the settings to their previous values.

NOTE

The settings are not applied until you restart the Document Centre.

TCP/IP

To specify TCP/IP settings:

1. Open your Web browser and enter the TCP/IP address of the Document Centre in the Address or Location field.
2. Click the **Properties** tab or click **Properties** in the directory tree.
3. Select **Connectivity**, then select **Protocols** in the directory tree.
4. Select **TCP/IP** in the directory tree.

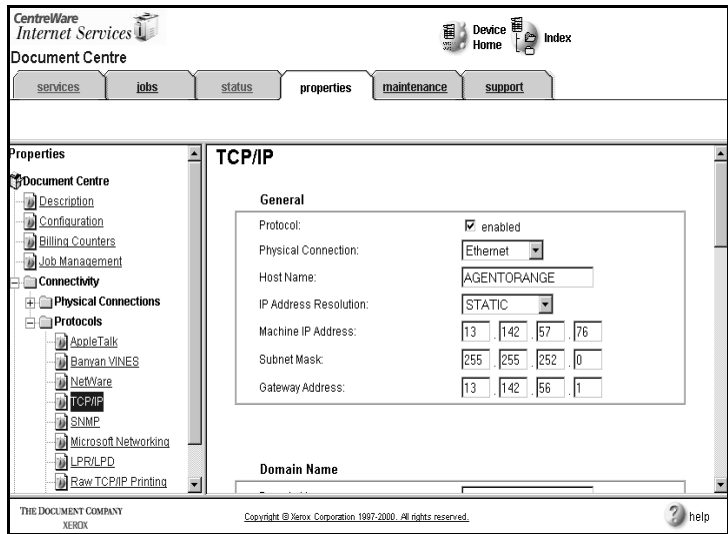

5. Select **Protocol Enabled** to enable TCP/IP.

CAUTION:

Disabling TCP/IP will affect NetBIOS/IP, LPR/LPD, FTP, SNMP, and Raw TCP/IP printing. Internet Services will not be available until TCP/IP is enabled from the control panel of the Document Centre.

6. If your Document Centre has an enabled token ring card, select either Ethernet or Token Ring from the **Physical Connection** drop-down list.

7. Type a **Host Name**.
8. Select DHCP, RARP, BOOTP, STATIC, or DHCP/AutoIP from the **IP Address Resolution** drop-down list.
9. Type the desired IP addresses that apply in **Machine IP Address, Subnet Mask, and Gateway Address**.

NOTE

If BOOTP or DHCP address resolution mode is selected, you cannot change the IP address, subnet mask, or default gateway. If RARP address resolution mode is selected, you cannot change the IP address.

CAUTION:

Changing the IP address for the Document Centre will affect NetBIOS/IP, LPR/LPD, FTP, SNMP, and Port 9100 printing. If you change an IP address for a device, you must reference the new address for TCP/IP to locate the device.

10. For DNS configuration, type in the **Domain Name**.
11. Type in the IP address for the **Preferred DNS Server**.
12. Type in the IP address for **Alternate DNS Servers 1** and **2**.
13. Click to select for **Dynamic DNS Registration enabled**.
14. For SLP Configuration, set **Protocol: enabled** to enable Service Location Protocol (SLP).
15. Type in the IP address for the **Directory Agent**.
16. Type in the name(s) for **Scope 1, 2, 3**.
17. Select the Message Type from the drop-down list for **Multi-cast** or **Broadcast**.
18. Type in a value for **Multicast Radius** (0 - 255).
19. Type in a value for **MTU** (484 - 1400) to set the Maximum Transmission Unit.
20. Click **Apply New Settings** to accept the changes or **Restore Settings** to return the settings to their previous values.

NOTE

The settings are not applied until you restart the Document Centre.

Simple Network Management Protocol (SNMP)

These pages allow you to remotely define and modify GET, SET, and Trap SNMP community names for the Document Centre. You can also configure SNMP trap destinations for TCP/IP and NetWare (IPX) that will receive traps from Document Centres on the network.

SNMP Community Name properties that can be configured are:

- **GET**—returns the password for SNMP GET requests to the Document Centre. Applications, such as Xerox Printer Map or CentreWare, obtaining information from the device via SNMP use this password.
- **SET**—returns the password for SNMP SET requests to the Document Centre. Applications, such as Xerox Printer Map or CentreWare, that set information on the device via SNMP use this password.
- **TRAP**—returns the password for SNMP TRAPS from the Document Centre. This is the default password for SNMP TRAPS sent from the device via SNMP.

To configure SNMP community names:

1. Open your Web browser and enter the TCP/IP address of the Document Centre in the Address or Location field.
2. Click the **Properties** tab or click **Properties** in the directory tree. Select **Connectivity**, then select **Protocols** in the directory tree.
3. Select **SNMP Configuration** in the directory tree.

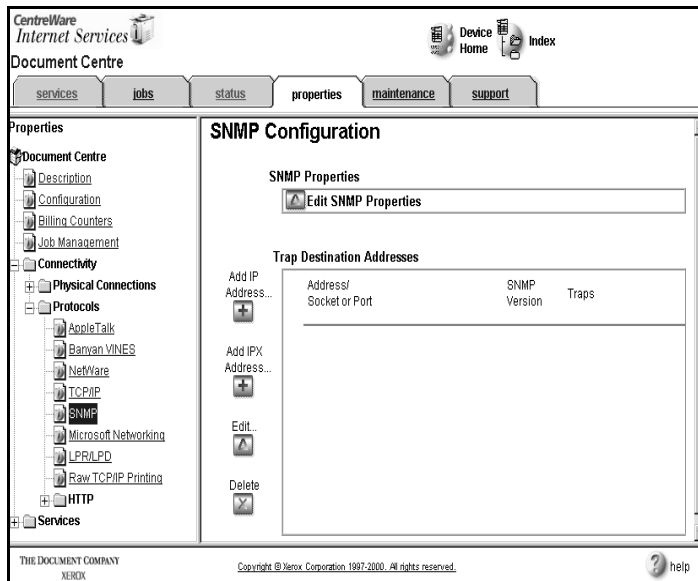

4. This SNMP Configuration screen will appear.

5. Click **Edit SNMP Properties**. You will be prompted for the Administrator name and password. Enter these and click OK.

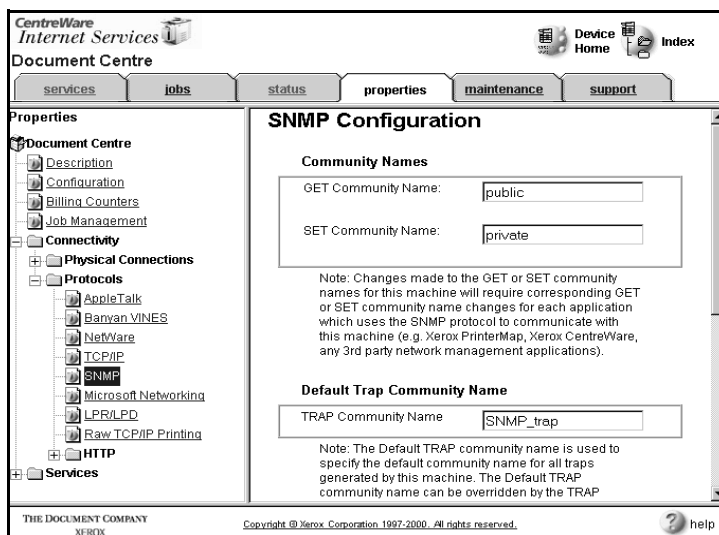

6. Enter a name (up to 256 characters) for the **GET Community Name**. The default is *public*.
7. Enter a name (up to 256 characters) for the **SET Community Name**. The default is *private*.

NOTE

If you change the GET and/or SET Community Names, you must change all network applications that are communicating via SNMP with this Document Centre to use the new GET/SET names.

8. Enter a name (up to 256 characters) for the default **TRAP Community Name**. The default is *SNMP_trap*.

9. Select to enable **Authentication Failure Generic Traps**.
10. Click **Apply New Settings** to accept the changes, **Restore Settings** to return the settings to their previous values, or **Default Settings** to return the settings to their default values.

To Add IP Addresses to the Trap Destination Addresses list:

1. Open your Web browser and enter the TCP/IP address of the Document Centre in the Address or Location field.
2. Click the **Properties** tab or click **Properties** in the directory tree.
3. Select **Connectivity**, then select **Protocols** in the directory tree.
4. Select **SNMP Configuration** in the directory tree.
5. Click **Add IP Address**.

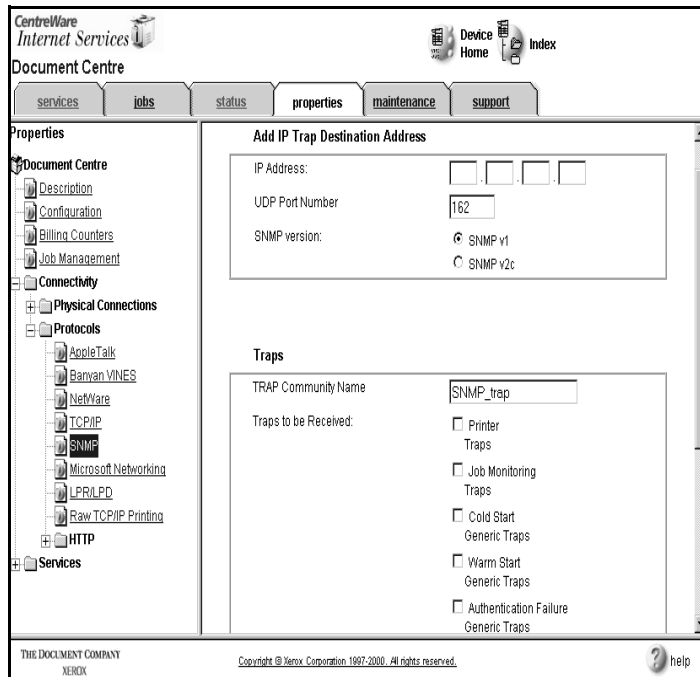

6. Enter the **IP Address** of the SNMP manager that will receive traps.

7. Enter a **UDP Port Number** of the SNMP manager that will receive traps. The default is 162 (decimal).
8. Select the **SNMP version** that matches the version of the SNMP manager. The default is SNMP v1.
9. Enter the **Trap Community Name**.
10. Select the **Traps to be Received**:
 - Printer Traps
 - Job Monitoring Traps
 - Cold Start Generic Traps
 - Warm Start Generic Traps
 - Authentication Failure Generic Traps

NOTE

Authentication Failure Generic Traps must be enabled on the SNMP Properties Configuration Page before you can select it.

11. Click **Apply New Settings** to accept the changes or **Restore Settings** to return the settings to their previous values.

To Add IPX Addresses to the Trap Destination Addresses List:

1. Open your Web browser and enter the TCP/IP address of the Document Centre in the Address or Location field.
2. Click the **Properties** tab or click **Properties** in the directory tree.
3. Select **Connectivity**, then select **Protocols** in the directory tree.

4. Select **SNMP Configuration** in the directory tree.
5. Click **Add IPX Address**.

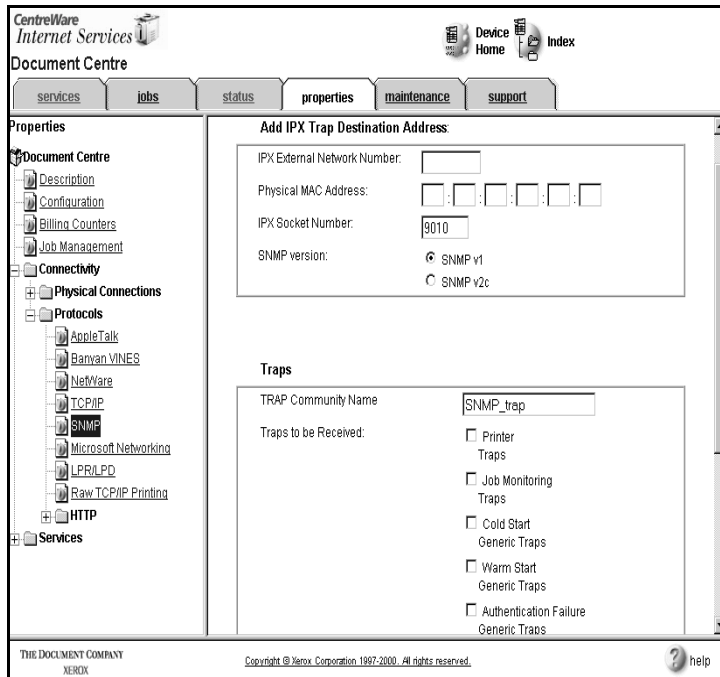

6. Enter the **IPX External Network Number** of the device that will receive traps.
7. Enter the **Physical MAC Address** of the device that will receive traps.
8. Enter the **IPX Socket Number** of the application that will listen for traps. The default is 9010 (hexadecimal).
9. Select the **SNMP version**. The default is SNMP v1.
10. Select the **Traps to be Received**:
 - **Printer Traps**
 - **Job Monitoring Traps**
 - **Cold Start Generic Traps**
 - **Warm Start Generic Traps**
 - **Authentication Failure Generic Traps**

NOTE

Authentication Failure Generic Traps must be enabled on the SNMP Properties Configuration Page before you can select it.

11. Click **Apply New Settings** to accept the changes or **Restore Settings** to return the settings to their previous values.

To edit IP or IPX Trap Destinations:

1. Open your Web browser and enter the TCP/IP address of the Document Centre in the Address or Location field.
2. Click the **Properties** tab or click **Properties** in the directory tree.
3. Select **Connectivity**, then select **Protocols** in the directory tree.
4. Select **SNMP Configuration** in the directory tree.
5. Select an IP or IPX address in the Trap Destination Addresses list.
6. Click **Edit**.
7. Make any changes to **Traps to be Received**.
8. Click **Apply New Settings** to accept the changes or **Restore Settings** to return the settings to their previous values.

To delete IP or IPX Trap Destinations:

1. Open your Web browser and enter the TCP/IP address of the Document Centre in the Address or Location field.
2. Click the **Properties** tab or click **Properties** in the directory tree.
3. Select **Connectivity**, then select **Protocols** in the directory tree.
4. Select **SNMP Configuration** in the directory tree.
5. Select one or more IP or IPX address in the Trap Destination Addresses list.
6. Click **Delete**.
7. Click **OK** to confirm the deletion.

Microsoft Networking

1. Open your Web browser and enter the TCP/IP address of the Document Centre in the Address or Location field.
2. Click the **Properties** tab or click **Properties** in the directory tree.
3. Select **Connectivity**, then select **Protocols** in the directory tree.
4. Select **Microsoft Networking** in the directory tree.

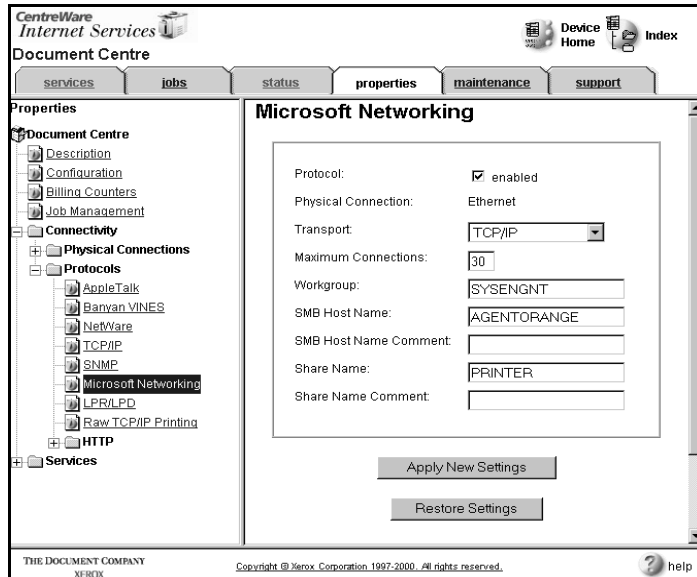

5. Select **Protocol Enabled** to enable Microsoft Networking.
6. Select Ethernet or Token Ring from the **Physical Connection** drop-down list.

NOTE

Physical Connection is read only if **Transport** is NetBIOS/IP.

7. Select TC/PIP or NetBIOS/NetBEUI from the **Transport** drop-down list.

NOTE

Transport is NetBEUI if TCP/IP is not enabled.

8. Type the maximum number of connections allowed in **Maximum Connections**.
9. Select the workgroup from the **Workgroup** drop-down list.
10. Type the **SMB Host Name** and optionally type a descriptive comment in **SMB Host Name Comment**.
11. Type the **Share Name** and optionally type a descriptive comment in **Share Name Comment**.
12. Click **Apply New Settings** to accept the changes or **Restore Settings** to return the settings to their previous values.

NOTE

The settings are not applied until you restart the Document Centre.

Line Printer Daemon (LPR/LPD)

To specify LPR/LPD settings:

1. Open your Web browser and enter the TCP/IP address of the Document Centre in the Address or Location field.
2. Click the **Properties** tab or click **Properties** in the directory tree.
3. Select **Connectivity**, then select **Protocols** in the directory tree.

4. Select **LPR/LPD** in the directory tree.

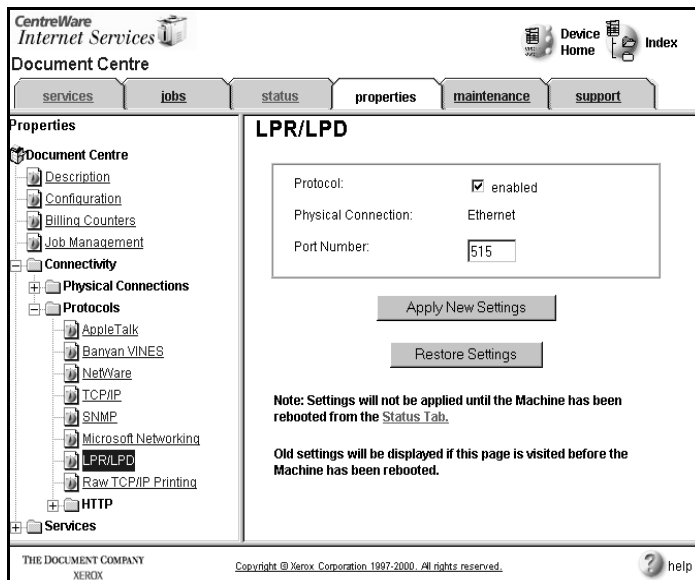

5. Select **Protocol Enabled** to enable LPR/LPD.
6. Enter a **Port** number. The default is 515.
7. Click **Apply New Settings** to accept the changes or **Restore Settings** to return the settings to their previous values.

NOTE

The settings are not applied until you restart the Document Centre.

Raw TCP/IP Printing

NOTE

TCP/IP must be enabled.

Raw TCP/IP is a printing protocol that is similar to LPR printing. Also known as a direct TCP/IP connection or sockets interface, it sends information directly to the Document Centre and does not require a Line Printer Daemon (LPD). The advantages are that connections stay open for multiple print files and spooling is not needed, therefore, printing is faster and more reliable than LPD printing.

Raw TCP/IP printing is contained in Windows 2000 and other third-party applications and operating systems.

To specify Raw TCP/IP printing settings:

1. Open your Web browser and enter the TCP/IP address of the Document Centre in the Address or Location field.
2. Click the **Properties** tab or click **Properties** in the directory tree.
3. Select **Connectivity**, then select **Protocols** in the directory tree.

4. Select **Raw TCP/IP Printing** in the directory tree.

The screenshot shows the CentreWare Internet Services Document Centre interface. The top navigation bar includes tabs for services, jobs, status, properties, maintenance, and support. The left sidebar shows a tree view with categories like Document Centre, Configuration, Billing Counters, Job Management, Connectivity, Physical Connections, Protocols, and Services. The 'Raw TCP/IP Printing' option is selected under Protocols. The main content area displays the configuration for 'Raw TCP/IP Printing' with the following settings:

Protocol:	<input checked="" type="checkbox"/> enabled
Physical Connection:	Ethernet
Transport:	TCP/IP
Port Number:	<input type="text" value="9100"/>

Below the settings are two buttons: 'Apply New Settings' and 'Restore Settings'. A note states: 'Note: Settings will not be applied until the Machine has been rebooted from the Status Tab. Old settings will be displayed if this page is visited before the Machine has been rebooted.'

At the bottom of the interface, there is a footer with 'THE DOCUMENT COMPANY XEROX', 'Copyright © Xerox Corporation, 1997-2000. All rights reserved.', and a 'help' link.

5. Select **Protocol Enabled** to enable Raw TCP/IP Printing.
6. Click **Apply New Settings** to accept the changes or **Restore Settings** to return the settings to their previous values.

NOTE

The settings are not applied until you restart the Document Centre.

HTTP Settings

These properties are used to select configuration and security parameters for the Document Centre's embedded HTTP server. Network Administrators can set general configuration, network configuration, and security for the printer.

These settings are the defaults for how the embedded HTTP server manages connections.

To modify the HTTP configuration settings:

1. Open your Web browser and enter the TCP/IP address of the Document Centre in the Address or Location field.
2. Click the **Properties** tab or click **Properties** in the directory tree.
3. Select **Connectivity**, then select **Protocols** in the directory tree.
4. Select **HTTP** in the directory tree.

5. Select **Configuration** in the directory tree.



6. Enter the number of seconds (1 - 60) that a browser connection can remain open without any activity in **Keep Alive Timeout**.

NOTE

Generally, longer amounts of time that a user is connected will tend to slow down and tie up connections. **Keep Alive Timeout** controls the number of seconds that connections remain open from the HTTP server side without any requests from the client reaching the server. If a new request reaches the HTTP server before the timeout occurs, the server will use the already open connection to service the request. If the client connection timed out before a new request was sent, the server will handle it as a new connection.

7. Type from 1 - 60 maximum number of connections in **Maximum Connections**.

NOTE

MaxConnectCount controls the maximum number of clients that can be connected (for example, with open sockets) to the HTTP server at any one time. The HTTP server stops listening for new connections when the number of connected clients reaches the maximum number of connections set in this field. A connection attempt that occurs while the HTTP server is not listening for connections is placed on the TCP listen queue and will be serviced when listening resumes. If the TCP listen queue becomes full, TCP will reject additional connection attempts immediately. The HTTP server resumes listening when the number of connections drops below the maximum allowable number.

8. Click **Apply New Settings** to accept the changes or **Restore Settings** to return the settings to their previous values.

NOTE

The settings are not applied until you restart the Document Centre.

Setting Security

The HTTP Settings pages are used to set up access to the Document Centre's embedded HTTP server. You can set up security by defining IP address restrictions.

Users are then restricted from accessing certain web pages (files and directories) unless they have the appropriate client IP address.

The security settings are saved in a configuration file for the specific Document Centre's embedded HTTP server and apply only to that HTTP server.

Defining IP Restrictions

The Edit IP Restriction Settings Page is used to define the IP addresses that can or cannot access certain web pages (files or directories) on the embedded HTTP server. By entering an IP address and clicking the appropriate button, you can allow or restrict access.

NOTE

Ensure that you know your network configuration and user's browser configurations. The HTTP Server allows/restricts access to the IP addresses as they appear in the list. For example, if users connect through a proxy server to access a Document Centre, the proxy server's IP address needs to be restricted to restrict the access of those particular users.

An asterisk (*) can be used in the address as a wildcard. Using the wildcard includes or restricts (depending whether you are allowing or restricting access) all host addresses and/or subnet addresses. For example, 192.246.238.* references a subnet, 192.246.* references a wider subnet, 192.* references the widest subnet, and * references all host addresses.

When a request is made to access the web site, the embedded HTTP server checks the IP Address Permissions list to determine if the requesting IP address is allowed access. The HTTP server begins at the top of the list and stops when it finds the first entry that matches the IP address requesting access.

If there are two entries that correspond to the same IP address, the first one in the list is used. The list explicitly determines access;

therefore, it is very important to be aware of the entries and their order in the IP Address Permissions list.

For example, the list entry +192.246.238.* indicates that only this subnet has access to the device. The list entry -192.246.238.* indicates that no client has access to the device since there are no granted permissions in the list.

You may want to leave +* at the end of the list to ensure that if the HTTP server does not find a matching entry, then it will allow the IP address access when it finds +*.

For example, the following list entry indicates that only the IP addresses in the restricted subnet do not have access to the device:

-192.246.238.*

+*

To grant permissions:

1. Open your Web browser and enter the TCP/IP address of the Document Centre in the Address or Location field.
2. Click the **Properties** tab or click **Properties** in the directory tree.
3. Select **Connectivity**, then select **HTTP** in the directory tree.

4. Select **IP Restrictions** in the directory tree.

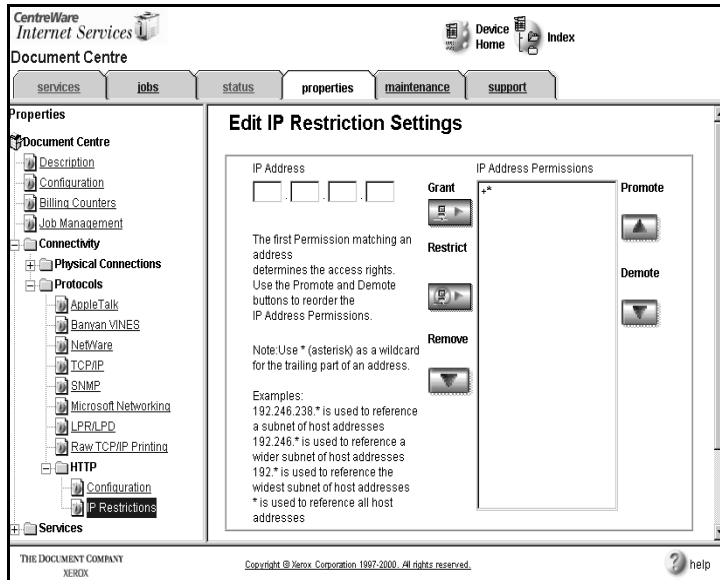

5. Enter an IP address.
6. Click **Grant**. The IP address is added to the IP Address Permissions list.
7. Click **Apply New Settings** to accept the changes or **Restore Settings** to return the settings to their previous values.

NOTE

The settings are not applied until you restart the Document Centre.

To restrict permissions:

1. Open your Web browser and enter the TCP/IP address of the Document Centre in the Address or Location field.
2. Click the **Properties** tab or click **Properties** in the directory tree.
3. Select **Connectivity**, then select **HTTP** in the directory tree.
4. Select **IP Restrictions** in the directory tree.
5. Enter an IP address.
6. Click **Restrict**. The IP address is added to the IP Address Permissions list.
7. Click **Apply New Settings** to accept the changes or **Restore Settings** to return the settings to their previous values.

NOTE

The settings are not applied until you restart the Document Centre.

To remove an IP address from the list:

1. Open your Web browser and enter the TCP/IP address of the Document Centre in the Address or Location field.
2. Click the **Properties** tab or click **Properties** in the directory tree.
3. Select **Connectivity**, then select **HTTP** in the directory tree.
4. Select **IP Restrictions** in the directory tree.
5. Select an IP address in the IP Address Permissions list.
6. Click **Remove**. The selected address is removed from the list.
7. Click **Apply New Settings** to accept the changes or **Restore Settings** to return the settings to their previous values.

NOTE

The settings are not applied until you restart the Document Centre.

To move IP Address Permissions within the list:

1. Select an IP address in the IP Address Permissions list.
2. Click **Promote** to move the selected IP address up the list.
3. Click **Demote** to move the selected IP address down the list.

Services Properties are used to specify general printing options for your Document Centre and scanning defaults for your Internet Services print jobs.

Printing

Printing Properties allow you to set general, view printer language, and view Tagged Image File Format (TIFF) defaults for printing on your Document Centre.

General

1. Open your Web browser and enter the TCP/IP address of the Document Centre in the Address or Location field.
2. Click the **Properties** tab or click **Properties** in the directory tree.
3. Select **Services**, then select **Printing** in the directory tree.

4. Select **General** in the directory tree.

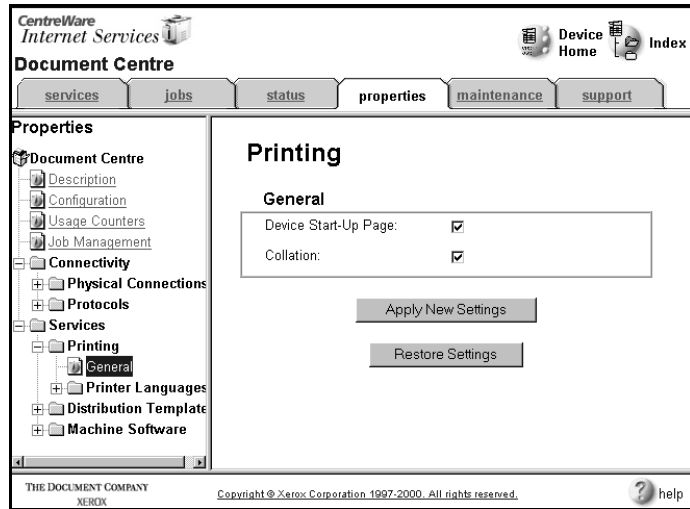

5. Select **Device Start-Up Page** to print a configuration report when the Document Centre is powered on.
6. Select **Collation** to specify collated as the default for document sets.
7. Click **Apply New Settings** to accept the changes or **Restore Settings** to return the settings to their previous values.

Printer Languages

Printer Languages displays the PostScript, PCL, or TIFF output settings for the Document Centre.

PostScript

1. Open your Web browser and enter the TCP/IP address of the Document Centre in the Address or Location field.
2. Click the **Properties** tab or click **Properties** in the directory tree.
3. Select **Services**, then select **Printing** in the directory tree.
4. Select **Printer Languages** in the directory tree.
5. Select **PostScript** in the directory tree.

The Adobe PostScript level and version displays on the page.

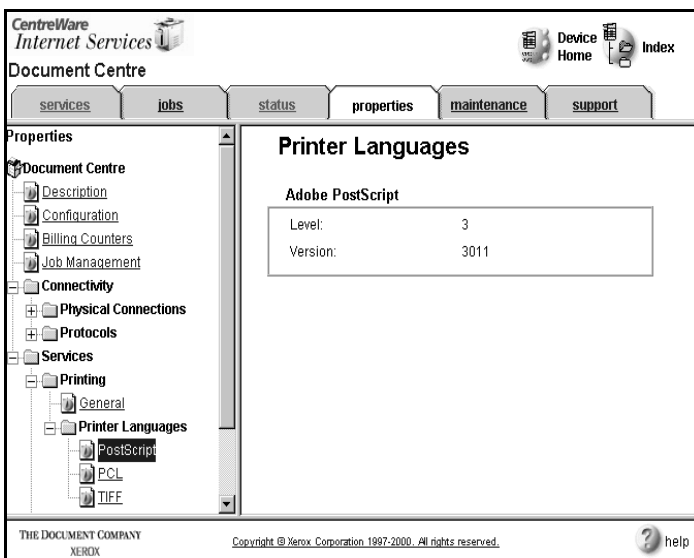

The screenshot shows the CentreWare Internet Services web interface. The top navigation bar includes 'services', 'jobs', 'status', 'properties', 'maintenance', and 'support'. The 'properties' tab is selected. On the left, a directory tree shows 'Document Centre' expanded to 'Services' > 'Printing' > 'Printer Languages' > 'PostScript'. The main content area is titled 'Printer Languages' and displays the following information:

Adobe PostScript	
Level:	3
Version:	3011

At the bottom of the interface, there is a footer with 'THE DOCUMENT COMPANY XEROX' on the left, 'Copyright © Xerox Corporation 1987-2000. All rights reserved.' in the center, and a 'help' icon on the right.

PCL

1. Open your Web browser and enter the TCP/IP address of the Document Centre in the Address or Location field.
2. Click the **Properties** tab or click **Properties** in the directory tree.
3. Select **Services**, then select **Printing** in the directory tree.
4. Select **Printer Languages** in the directory tree.
5. Select **PCL** in the directory tree.

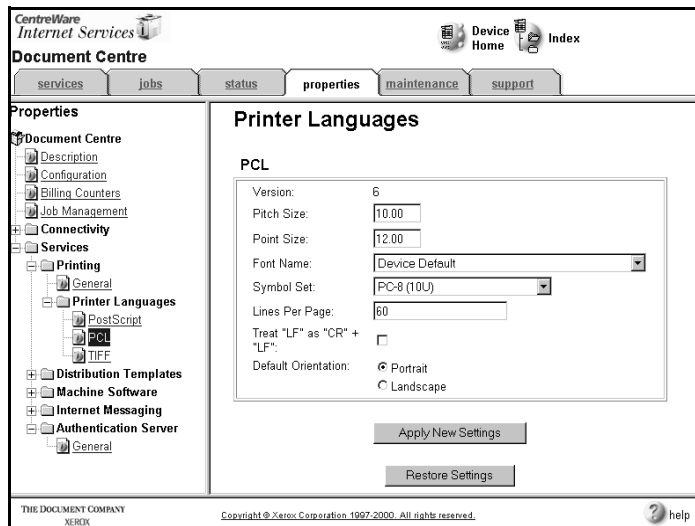

6. Type the **Pitch Size** (0.44 - 99.99).
7. Type the **Point Size** (4.00 - 999.75).
8. Select a font from the **Font Name** drop-down list.
9. Select a symbol set from the **Symbol Set** drop-down list.
10. Type the number of **Lines Per Page** (5 - 180).

NOTE

For **Lines Per Page**, the default is 60.

11. Select **Treat "LF" as "CR"+"LF"**.
12. Select **Default Orientation** for portrait or landscape orienta-

tion.

13. Click **Apply New Settings** to accept the changes or **Restore Settings** to return the settings to their previous values.

Tagged Image File Format (TIFF)

To view TIFF settings:

1. Open your Web browser and enter the TCP/IP address of the Document Centre in the Address or Location field.
2. Click the **Properties** tab or click **Properties** in the directory tree.
3. Select **Services**, then select **Printing** in the directory tree.
4. Select **Printer Languages** in the directory tree.
5. Select **TIFF** in the directory tree. The TIFF version displays on the page.

Distribution Templates

Distribution templates specify the default scanning template options used for scanning with Internet Services. The default distribution template is accessed from the Services Page by users, but is defined by Network Administrators from the Distribution Template Properties Page.

The Document Centre includes a system template that is available from the embedded HTTP server. This template has factory settings. The first step is to create a default template for users and then save it with a new name. You can use the factory template settings or customize the settings for your site. Once the default template is available, it can be modified for personal use and saved as a custom template by users.

You can create a default template specifically for Scan to File or Scan to Fax.

NOTE

Faxing on the Document Centre is only available with an external faxing hardware and software solution.

General

General settings are the overall options for scanning using Internet Services.

To specify general settings:

1. Open your Web browser and enter the TCP/IP address of the Document Centre in the Address or Location field.
2. Click the **Properties** tab or click **Properties** in the directory tree.
3. Select **Services**, then select **Distribution Templates** in the directory tree.

NOTE

If Distribution Templates is not selectable, Scanning is not enabled on the Document Centre.

4. Select **General** in the directory tree.

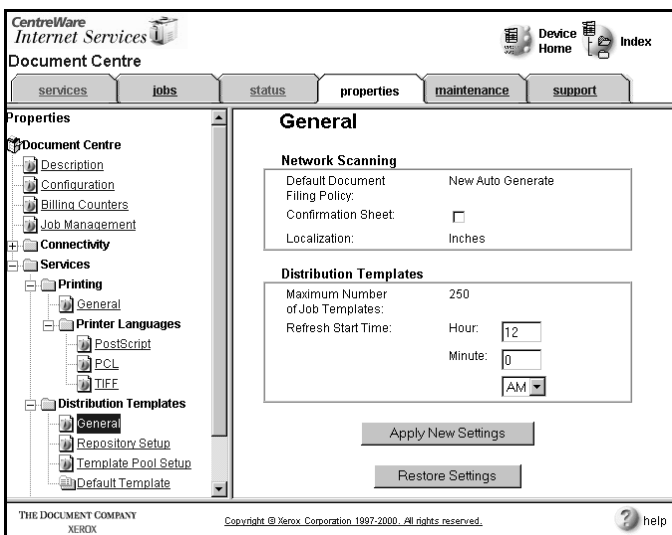

5. Displays the **Default Document Filing Policy**:

- **Append to Existing File** — adds the new file to the previously scanned folder in the specified repository.
- **Overwrite Existing File** — overwrites the folder and file that were previously scanned with the new folder and file.
- **Do Not Save** — matches the document name for the folder specified in the template.
- **Rename New File** — generates an alphanumeric name for the folder based on the document name specified in the template. The folder names increment accordingly when more documents are scanned to this location. You can scan up to 999 times with a particular template using Rename New File. After that number, an error sheet is generated by the Document Centre.

6. Select to enable a **Confirmation Sheet**.
7. **Localization** and the **Maximum Number of Job Templates** settings display on the page.
8. Type the Hour, Minute, and select the time of day from the drop-down list for **Refresh Start Time**. The refresh start time is when the Network Scanning Service checks the template pool for new templates and automatically updates the list on the Document Centre Touch Screen.
9. Click **Apply New Settings** to accept the changes or **Restore Settings** to return the settings to their previous values.

Repository Setup

A Document Repository is a directory or folder on a network file server where documents are saved after they are scanned. A Fax Repository, which is the location where scanned documents are placed until they are automatically faxed using RightFax software, can also be defined on this page. There are separate Repository Setup Pages for TCP/IP and NetWare.

To specify repository setup settings for TCP/IP:

1. Open your Web browser and enter the TCP/IP address of the Document Centre in the Address or Location field.
2. Click the **Properties** tab or click **Properties** in the directory tree.
3. Select **Services**, then select **Distribution Templates** in the directory tree.

4. Select **Repository Setup** in the directory tree.

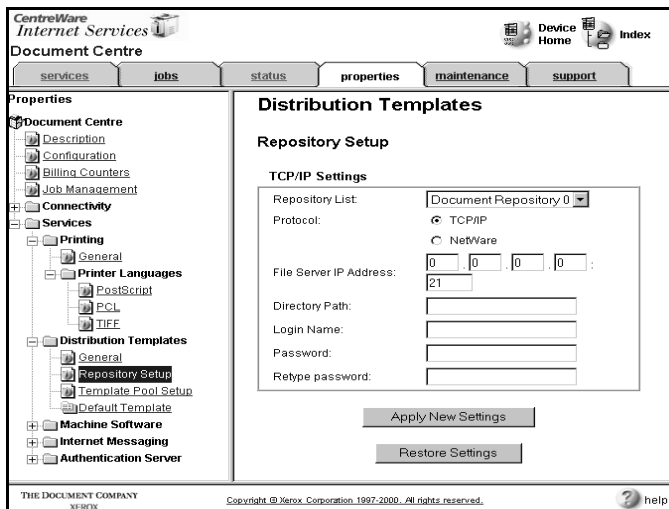

5. Select a repository from the **Repository List** drop-down list.
6. Select TCP/IP for **Protocols**.
7. Type the IP address for the repository server in **File Server IP Address**.
8. Type the path for the repository in **Directory Path**.
9. Type the **Login Name** and **Password** for the repository. Retype the password to verify it in **Retype Password**.
10. Click **Apply New Settings** to accept the changes or **Restore Settings** to return the settings to their previous values.

To specify repository setup settings for NetWare:

1. Open your Web browser and enter the TCP/IP address of the Document Centre in the Address or Location field.
2. Click the **Properties** tab or click **Properties** in the directory tree.
3. Select **Services**, then select **Distribution Templates** in the directory tree.
4. Select **Repository Setup** in the directory tree.
5. Select a repository from the **Repository List** drop-down list.

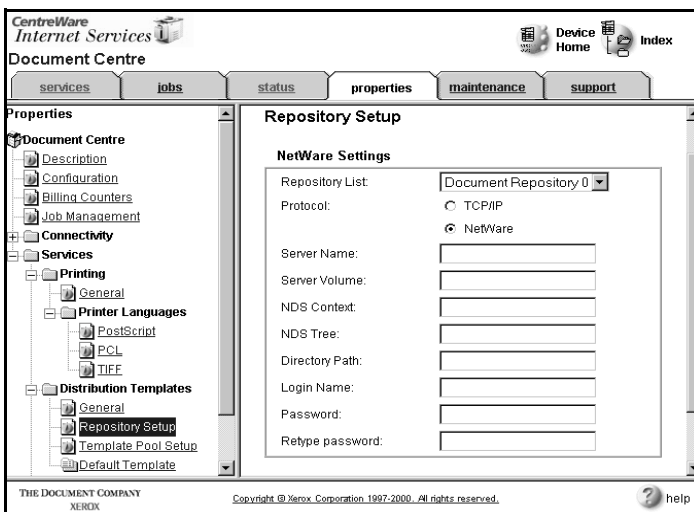

6. Select NetWare for **Protocols**.
7. Type the name of the repository server in **Server Name**.
8. Type the name of the server volume (NetWare 3.x, 4.x, 5.x (*IPX only*)) in **Server Volume**.
9. Type the context and tree (NetWare 4.x, 5.x (*IPX only*)) for the repository in **NDS Context** and **NDS Tree**.
10. Type the path for the repository in **Directory Path**.
11. Type the **Login Name** and **Password** for the repository. Retype the password to verify it in **Retype Password**.
12. Click **Apply New Settings** to accept the changes or **Restore Settings** to return the settings to their previous values.

Template Pool Setup

A template pool is a directory location on a network file server where scan distribution templates are stored.

To specify template pool setup settings for TCP/IP:

1. Open your Web browser and enter the TCP/IP address of the Document Centre in the Address or Location field.
2. Click the **Properties** tab or click **Properties** in the directory tree.
3. Select **Services**, then select **Distribution Templates** in the directory tree.
4. Select **Template Pool Setup** in the directory tree.

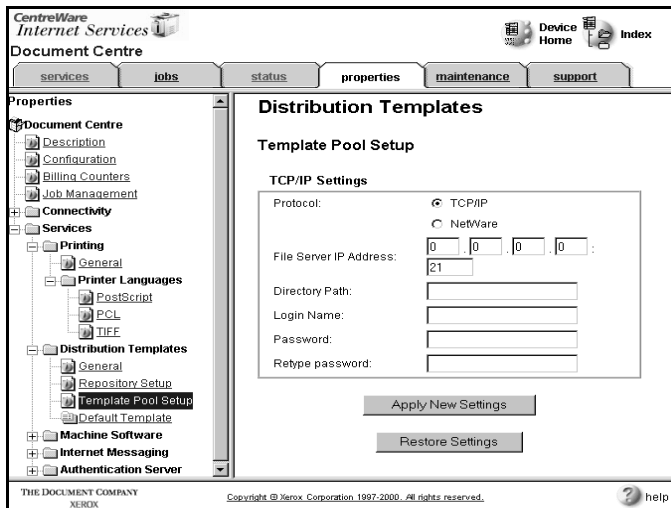

5. Select TCP/IP for **Protocols**.
6. Type the IP address for the repository server in **File Server IP Address**.
7. Type the path for the repository in **Directory Path**.
8. Type the **Login Name** and **Password** for the repository. Retype the password to verify it in **Retype Password**.
9. Click **Apply New Settings** to accept the changes or **Restore Settings** to return the settings to their previous values.

To specify template pool setup settings for NetWare:

1. Open your Web browser and enter the TCP/IP address of the Document Centre in the Address or Location field.
2. Click the **Properties** tab or click **Properties** in the directory tree.
3. Select **Services**, then select **Distribution Templates** in the directory tree.
4. Select **Template Pool Setup** in the directory tree.

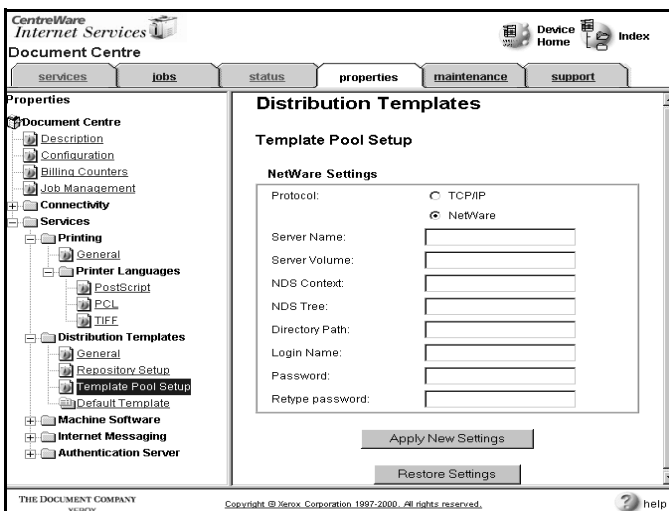

5. Select NetWare for **Protocols**.
6. Type the name of the repository server in **Server Name**.
7. Type the name of the server volume (NetWare 3.x, 4.x, 5.x (*IPX only*)) in **Server Volume**.
8. Type the context and tree (NetWare 4.x, 5.x (*IPX only*)) for the repository in **NDS Context** and **NDS Tree**.
9. Type the path for the repository in **Directory Path**.
10. Type the **Login Name** and **Password** for the repository. Retype the password to verify it in **Retype Password**.
11. Click **Apply New Settings** to accept the changes or **Restore Settings** to return the settings to their previous values.

Default Template

The Default Template Properties Page allows a Network Administrator to modify the default template values. Information set on this page is used to create any new templates on the Document Centre.

The Network Administrator can revert from the changed template to the factory default settings by clicking **Restore to Factory Defaults**.

NOTE

For information on editing distribution templates for scanning using Internet Services, see the Scanning Documents section of this chapter.

To create a default template for use with Internet Services:

1. Open your Web browser and enter the TCP/IP address of the Document Centre in the Address or Location field.
2. Click the **Properties** tab or click **Properties** in the directory tree.
3. Select **Services**, then select **Distribution Templates** in the directory tree.
4. Select **Default Template** in the directory tree.

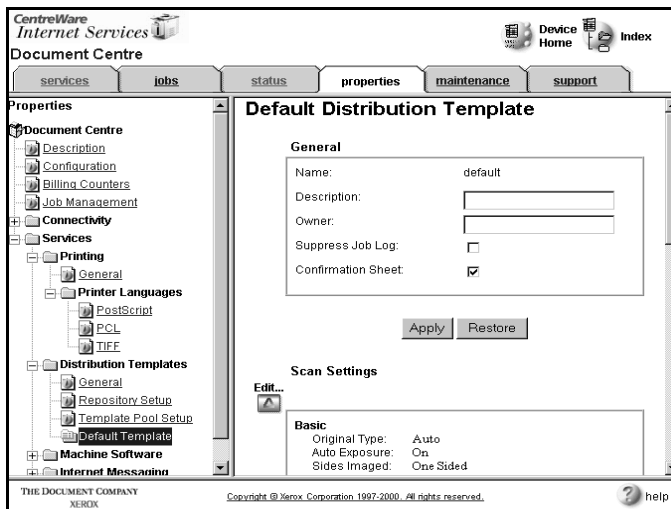

5. Scroll down the page and click **Add**, **Edit**, or **Delete** to access and modify the Scan Settings, Distribution Settings, or Document Management Fields.

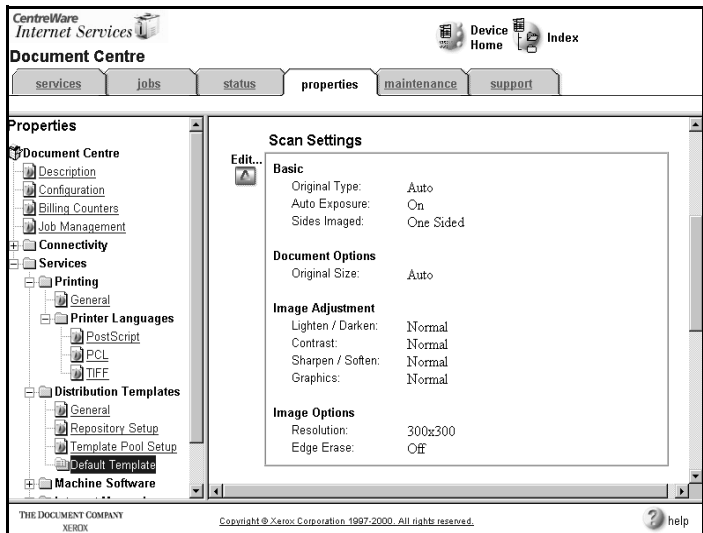

6. Review the tables on the following pages that show the setting names and a description of the feature, then make the desired selections.
7. Save the template with a new name for use as the default template for Internet Services.
8. Click **Apply New Settings** to accept the changes or **Restore Settings** to return the settings to their previous values.
9. When finished, click **Apply Factory Default Settings** to reset the factory default template to the factory settings.

Scan Settings



The following table shows the available scan settings that can be defined in a template and a description of each.

Category	Setting	Description
Basic	Original Type	Auto (default) automatically detects the type of original. Text indicates that the original is text or line art. Photo indicates that the original is a photograph.
	Auto Exposure	Used for enhancing documents with colored backgrounds by adjusting for different types of images. On (checkbox selected) selects an appropriate exposure level for the original document. Off (checkbox deselected) uses the Lighten/Darken setting for the exposure level.
	Sides Imaged	Prints the image on one or two sides of the paper.
Document Options	Original Size	Selects the page dimensions of the scanned image to match the original size. Normal specifies a standard size (Letter or A4). Pre-set specifies a pre-defined size. Custom specifies a size that you set.
Image Adjustment	Lighten/Darken	Lightens or darkens the brightness of the printed image.
	Contrast	Adjust the clarity (difference in gray shades) of the printed image. Increased contrast makes the image more defined in black and white. Decreased contrast makes the image more defined in gray tones.
	Graphics	Normal sets the continuous-tone reproduction to 106 dpi screens. Emulate DocuTech allows Xerox DocuTech users to set the continuous-tone reproduction to emulate the DocuTech at a lower 85 dpi screen setting.
	Sharpen/Soft-en	Softens or makes the edges of the printed image more pronounced.
Image Options	Resolution	Prints the image in a selected number of dots per inch (dpi). A higher dpi, such as 600 x 600, produces a higher quality image, but creates a larger file size.
	Edge Erase	Erases the left/right/top/bottom margins of the document.

Distribute to File Settings

Category	Setting	Description
Filing Destination	Select from Repository Servers	Internet Service's ability to automatically send scanned images to File (folder) or Fax (fax recipient). Note: RightFax software is required for Faxing.
	Path to Document	Directory path for the scanned document.
	If Document Already Exists	Append to Existing File adds the new file to the previously scanned folder in the specified repository. Overwrite Existing File overwrites the folder and file that were previously scanned with the new folder and file. Do Not Save matches the document name for the folder specified in the template. Rename New File generates an alphanumeric name for the folder based on the document name specified in the template. The folder names increment when more documents are scanned. You can scan up to 999 times with a template using Rename New File. After that number, an error sheet is generated by the Document Centre.
	Document Name	Name of the scanned document.
	File Format	Tagged Image File Format (TIFF) of the scanned output file. TIFF (V4.0,V6.0) indicates that each page of the document is stored in a separate image file. Multi-Page TIFF (V4.0,V6.0) indicates that all pages of a document are stored in a single file. PDF indicates that the document pages will be stored as images in a Portable Document Format file. This mode does not support text-searchable PDF documents.

Distribute to Fax Settings

Category	Setting	Description
Fax	Delivery	immediate sends the fax immediately. delayed send sends the fax at the Hour/Minute and AM/PM specified.
Recipients		
	Enter Phone Number	Type the phone number and click  to add the number to the list. Click  to remove the number from the list.

Document Management Fields

Category	Setting	Description
Field Name	Enter Value	Name to match the document management software that will be processing the field.
User Editable	Yes/No	Select to determine if user will be able to modify Field Name. If Yes, requires Field Label. If No, Default Value is used.
Field Label	Enter Value	Identifies Field Name to user, if editable.
Default Value	Enter Value	Optional value used if user is not able to modify Field Name.

Machine Software

Auto Upgrade Scheduling

The Auto Upgrade feature allows you to schedule automatic machine software upgrades from a central server at a specific time on a daily basis, or hourly.

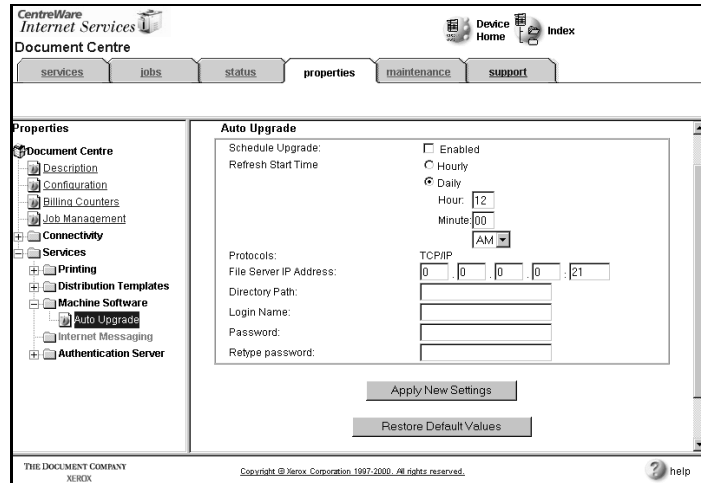

1. Open your Web browser and enter the TCP/IP address of the Document Centre in the Address or Location field.
2. Click the **Properties** tab or click **Properties** in the directory tree.
3. Select **Services**, then select **Machine Software** in the directory tree.
4. Check the **Enabled** box to enable the Auto Upgrade feature.
5. Check the **Hourly** or **Daily** box to activate the feature accordingly. If daily, enter the time of day to perform the upgrade.
6. Type the IP address for the upgrade server in **File Server IP Address**.
7. Type the path to the upgrade files in **Directory Path**.

8. Type the **Login Name** and **Password** for the upgrade server. Retype the password to verify it in **Retype Password**.
9. Click **Apply New Settings** to accept the changes or **Restore Settings** to return the settings to their previous values.

Internet Messaging

The Internet Messaging settings provide direct scan-to-E-mail capability on the Document Centre, with the following features:

- E-mail addressing at the Document Centre user interface
- E-mail directory integration with Lightweight Directory Access Protocol (LDAP)
- Support for Simple Message Transport Protocol (SMTP)
- Authentication/security

For authentication settings, refer to the next section of this chapter, Authentication Server.

For setup of all other scan-to-E-mail features, refer to Chapter 21 of this guide, E-mail.

Authentication Server

Authentication Server properties allow you to control access to the internet messaging capability of the Document Centre by selecting from three different authentication schemes (Kerberos, NDS, or SMB), in order to meet your system requirements.

Using Authentication Server properties, you can identify the default authentication server and two alternate servers. With DNS support, the Document Centre can be accessed by host name as well as by IP address.

General

The General setting specifies the authentication scheme that the Document Centre will be interfacing with on your network.

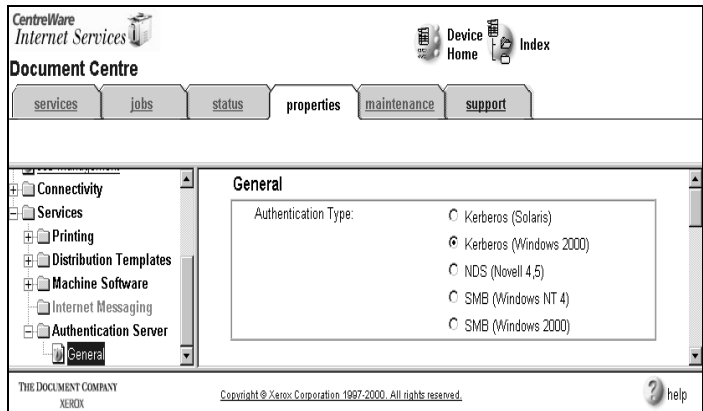

1. Open your Web browser and enter the TCP/IP address of the Document Centre in the Address or Location field.
2. Click the **Properties** tab or click **Properties** in the directory tree.
3. Select **Services**, then select **Authentication Server** in the directory tree.
4. Select **General** in the directory tree.
5. Click to select the **Authentication Type**:
Kerberos (Solaris)

Kerberos (Windows 2000)

NDS (Novell 4,5)

SMB (Windows NT 4)

SMB (Windows 2000)

Kerberos (Solaris)

To specify the Default Key Distribution Center and Alternates:

1. Refer to Authentication Server, General setting steps 1-5.
2. Click to select **IP Address** or **Host Name** identification.
3. Type in the **IP Address and optional Port** or **Host Name and optional Port**.
4. Type in the **Realm** name.
5. Type in the **Backup IP Address and optional Port** or **Backup Host Name and optional Port**.
6. Type in the Alternate Key Distribution Centers and backups.

The screenshot shows the 'Document Centre' properties window. The left sidebar lists various categories: Document Centre, Connectivity, Services, Printing, Distribution Templates, Machine Software, Internet Messaging, and Authentication Server. Under 'Authentication Server', the 'General' tab is active. The main content area is divided into two sections: 'Default Key Distribution Center' and 'Alternate Key Distribution Centers'. In the 'Default' section, 'Host Name' is selected, and the 'Realm' is set to 'eng.mc.xerox.com'. The 'Alternate' section contains two identical entries, each with fields for 'Alternate Host Name 1 and optional Port' and 'Alternate Backup Host Name 2 and optional Port', both with a port value of '88'.

7. Click **Apply New Settings** to accept the changes or **Restore Settings** to return the settings to their previous values.

Kerberos (Windows 2000)

To specify the Default Domain Controller and Alternates:

1. Refer to Authentication Server, General setting steps 1-5.
2. Click to select **IP Address** or **Host Name** identification.
3. Type in the **IP Address and optional Port** or **Host Name and optional Port**.
4. Type in the **Domain** name.
5. Type in the **Backup IP Address and optional Port** or **Backup Host Name and optional Port**.
6. Type in the Alternate Domain Controllers and backups.

CentreWare
Internet Services

Document Centre

services jobs status properties maintenance support

Properties

Document Centre

- Description
- Configuration
- Billing Counters
- Job Management
- Connectivity
- Services
- Printing
- Distribution Templates
- Machine Software
- Internet Messaging
- Authentication Server
 - General

Default Domain Controller

Name or IP Address: IP Address Host Name

IP Address and optional Port: [0] [0] [0] [0] : 88

Domain: eng.mc.xerox.com

Backup IP Address and optional Port: [0] [0] [0] [0] : 88

Alternate Domain Controllers

Alternate IP Address 1 and optional Port: [0] [0] [0] [0] : 88

Alternate Domain 1: []

Alternate Backup IP Address 1 and optional Port: [0] [0] [0] [0] : 88

Alternate IP Address 2 and optional Port: [0] [0] [0] [0] : 88

Alternate Domain 2: []

Alternate Backup IP Address 2 and optional Port: [0] [0] [0] [0] : 88

THE DOCUMENT COMPANY
XEROX

Copyright © Xerox Corporation, 1997-2000. All rights reserved.

help

7. Click **Apply New Settings** to accept the changes or **Restore Settings** to return the settings to their previous values.

NDS (Novell 4,5)

To specify the NDS Default Tree/Context and Alternates:

1. Refer to Authentication Server, General setting steps 1-5.
2. Type in a directory context for **NDS Context**.
3. Type in a directory tree for **NDS Tree**.
4. Type in a directory context and tree for **Alternate Tree/Context 1, 2**.

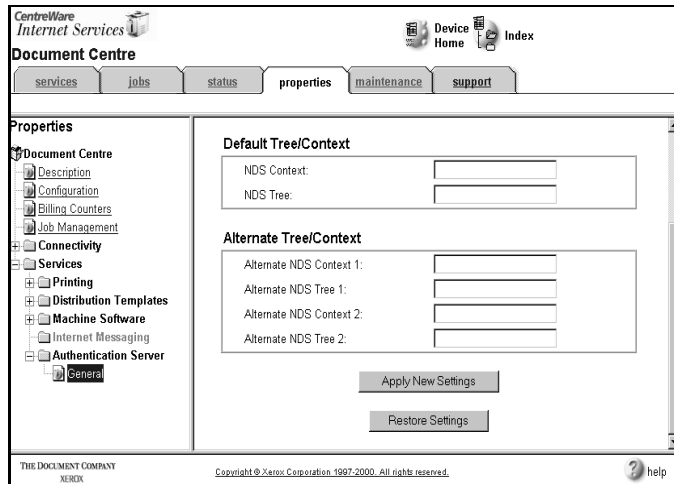

5. Click **Apply New Settings** to accept the changes or **Restore Settings** to return the settings to their previous values.

SMB (Windows NT 4 and Windows 2000)

To specify the SMB Default Domain and Alternates:

1. Refer to Authentication Server, General setting steps 1-5.
2. Type in the **Domain** name.
3. Type in the name(s) for **Alternate Domain 1, 2**.

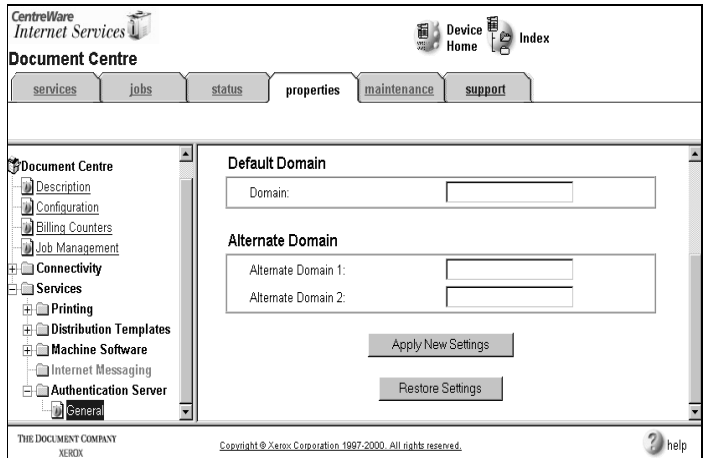

4. Click **Apply New Settings** to accept the changes or **Restore Settings** to return the settings to their previous values.

Testing the Document Centre

Testing the Document Centre explains how to print a test page, configuration report, view a font list, and install machine software using the Maintenance pages. Maintenance allows you to view and test the printing capabilities and install/update the ESS software of the Document Centre. You can print a configuration report which shows the network and Document Centre setup information. You can print or display in your browser a PostScript and PCL font listing that shows all the available fonts on the Document Centre.

Maintenance

The Maintenance Page provides options for testing printing functions and inquiring about the fonts that are available on the Document Centre. You can also install/upgrade the machine software for the Document Centre from the Maintenance page.

Display a Font List

Displays the PostScript and PCL fonts that are available.

To display the font list:

1. Open your Web browser and enter the TCP/IP address of the Document Centre in the Address or Location field.
2. Click **Maintenance** tab or click **Maintenance** on the Home Page.

3. Select **Printer Fonts** at the top of the Maintenance Page. The list of PCL and PostScript fonts that are available on the Document Centre appears on the page.
4. Click to select Samples, by category: PCL, Postscript, or Post-script and PCL. Click on **Print Font Samples** to print.
5. Click on the drop-down list to **View by Font Type**.

The screenshot shows the 'Printer Fonts' maintenance page in the CentreWare Internet Services interface. The page has a navigation bar with tabs for 'services', 'jobs', 'status', 'properties', 'maintenance', and 'support'. Under 'maintenance', there are three radio buttons: 'Printer Fonts' (selected), 'Machine Software', and 'Print Test Page'. On the left, there is a printer icon and details for 'Name: E53', 'Location: B311 Lab', 'IP: 13.175.112.153', and 'Address'. A status message indicates a warning: 'Status: warning-needs-attention'. Below this is a 'Refresh Status' button. The main content area is titled 'Printer Fonts' and contains a 'Samples' section with three radio buttons: 'All PostScript and PCL Fonts' (selected), 'Only PostScript Fonts', and 'Only PCL Fonts'. A 'Print Font Samples' button is located below these options. The 'List' section features a 'View by Font Type' dropdown menu set to 'All PostScript and PCL Fonts'. Below the dropdown is a table listing fonts with columns for Name, Type, and Persistence.

Name	Type	Persistence
ACaslon-Italic	PostScript	Permanent
ACaslon-Regular	PostScript	Permanent
ACaslon-Semibold	PostScript	Permanent
ACaslon-SemiboldItalic	PostScript	Permanent
AGaramond-Bold	PostScript	Permanent

At the bottom of the page, there is a footer with 'THE DOCUMENT COMPANY XEROX' on the left, 'Copyright © Xerox Corporation, 1997-2000. All rights reserved.' in the center, and a 'help' icon on the right.

Install Machine Software

Install Machine Software provides installation or upgrade of the Document Centre ESS software. Contact your Xerox representative or check the Xerox web site for the machine software file that you will need.

To install/upgrade machine software:

1. Open your Web browser and enter the TCP/IP address of the Document Centre in the Address or Location field.
2. Click the **Maintenance** tab or click **Maintenance** on the Home Page.
3. Select **Machine Software** at the top of the Maintenance Page.
4. When prompted, enter the administrator name and password for the Document Centre.

5. Browse for the machine software installation file. It will have the file extension **.tgz**.
6. Click **Install Software** to perform the installation.

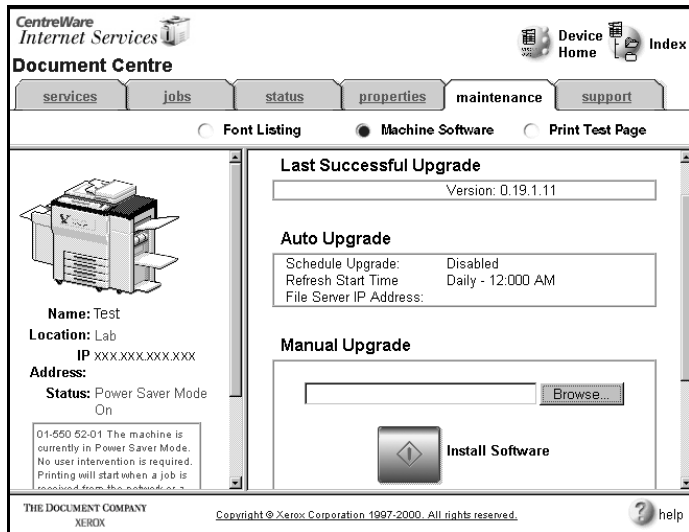

Printing a Test Page

Test Pages are special print jobs that contain test patterns for the Document Centre. These test patterns are used for checking printed image quality. You can also print a configuration report, which shows the Document Centre's configuration settings.

To test device printing:

1. Open your Web browser and enter the TCP/IP address of the Document Centre in the Address or Location field.
2. Click the **Maintenance** tab or click **Maintenance** on the Home Page.
3. Select **Print Test Page** at the top of the Maintenance Page.

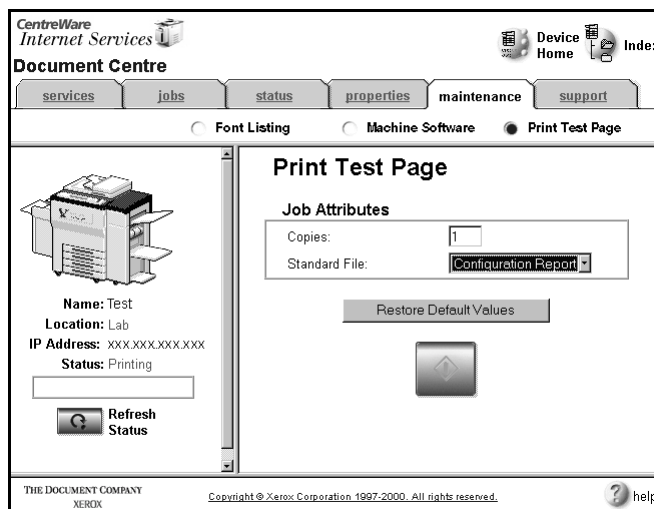

4. Type the number of copies to print.
5. Select a test page or configuration report to print from the **Standard File** drop-down list.
6. Click the print submission button to print the selected test page.
7. Click **Restore Default Values** to return the settings to their default values.

Getting Support

Getting Support explains how to perform tasks using the Support page. If you encounter problems that you cannot resolve or you need assistance with the Document Centre, the Support Page provides links to Internet/intranet support sites for software, Administrator contact information, and Xerox support information. From this page, an Administrator can enter the support information and make it available for Internet Services users of the Document Centre.

Viewing Support Information

Users can view the Document Centre and software information using Internet Services.

To view support information:

1. Open your Web browser and enter the TCP/IP address of the Document Centre in the Address or Location field.
2. Click the **Support** tab or click **Support** on the Home Page.

The Support Page appears, showing software, system, and Xerox information.

CentreWare
Internet Services

Document Centre

services jobs status properties maintenance support

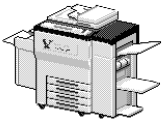

Name: Test
Location: Lab
IP Address: xxx.xxx.xxx.xxx
Status: Printing

Support

Software Upgrades

[CentreWare Internet Services Software](#)

Browser Software

[Internet Explorer](#)
[Netscape Navigator](#)

System Administrator

Administrator: not set
Phone Number: not set
Location: not set

Xerox Support

Customer Support: 1-800-821-2797
Service: 1-800-821-2797
Supplies: 1-800-822-2200

THE DOCUMENT COMPANY
XEROX

Copyright © Xerox Corporation 1997-2000. All rights reserved.

 help

Problem Solving

This section poses some simple solutions to common Internet Services problems. If you are having trouble running Internet Services, the following questions and answers may help you resolve the problem.

- **Are you using the correct browser version?** You should be using Netscape Navigator or Microsoft Internet Explorer 4.x and higher.
- **Did you enter the correct IP address for the Document Centre in your browser?** Go to the Document Centre control panel and check the IP address to make sure the IP addresses match.

17. Network Troubleshooting

Overview

This section of the **System Administration Guide** contains individual procedures for troubleshooting problems on each major network operating system or protocol.

These procedures will help you solve the common mistakes that are made during installation and repair problems that can occur later.

Because the Document Centre supports a wide variety of networks, each of the procedures is self contained. If your Document Centre is configured to print using multiple protocols it is recommended you follow one troubleshooting procedure at a time. This should save confusion and time.

Consult the procedure (or procedures) in this section that apply to your environment.

Basic TCP/IP Communication Problems

This procedure assumes that the printer is turned on and connected to a functioning network port with the correct cabling.

NOTE

Your Document Centre now has DHCP, LPR, and NetBIOS over the IP protocol enabled by default. If your DHCP server will provide host name, IP address, Gateway address, and Subnet Mask, the Document Centre TCP/IP information will be configured on initial boot. This means that if you have configured your DHCP server with the desired information, you should verify that the information is correct before you follow any of the procedures in this **TCP/IP Troubleshooting** section.

Obtain a Configuration Report from your printer.

1. Enter the **Tools** pathway.
 - a) Press the **Access** (**A** or ) button.
 - b) On the keypad enter **1111** or the current password. Press the **Enter** button when finished. The Touch Screen will be used for the remainder of the data entry, unless instructed otherwise.
 - c) Press the **Go to Tools** button.
 - d) Select **System Setting**.
 - e) Select **Configuration Report**.
 - f) Select **Print Configuration Report Now**.
 - g) Press the **Cancel** button.
 - h) Press the **Exit Tools** button.
2. Allow a minute for the Report to print.

3. Verify the following **TCP/IP Settings:** on the Configuration Report page:

Host Name (REMEMBER if you are connected to a UNIX network, it is CASE SENSITIVE!)

IP address

Subnet Mask

Default Gateway

Broadcast Address (if used)

NOTE

The Broadcast Address is calculated automatically.

4. To verify the Broadcast Address is correct the following calculation may be used:
Perform a logical OR of the complement of the subnet mask and the IP address.

Example of logical OR method:

IP Address = 13.175.109.146

Subnet Mask = 255.255.252.0

IP Address

00001101.10101111.01101101.10010010

Complement of Subnet Mask

00000000.00000000.00000011.11111111

The result of the logical OR

00001101.10101111.01101111.11111111

Broadcast Address = 13 . 175 . 111 . 255

5. Any one of these important TCP/IP parameters (if set incorrectly) can cause TCP/IP communication problems. Subnet Mask and Default Gateway are critical on multi-network segment LANs or WAN's. If you make any TCP/IP configuration changes, then the printer will reset for those changes to take effect.
6. Go to a workstation on the same subnet as the printer. And at a command line prompt TYPE ping xxxx.xxxx.xxxx.xxxx (xxx.xxxx.xxxx.xxxx is the IP address of the printer). Try to "ping" the printer using its hostname. If ping is successful with the printer's TCP/IP address but not with its hostname, then you may have a local workstation or NIS configuration problem. Check the Default Gateway settings of the printer.
7. Add the printer host name to your local hosts file or NIS database (whichever applies) and try the ping tests again.
8. Try to ping other TCP/IP nodes on your network. This will verify the operation of your workstation's network card. Try to "ping" the printer from another workstation. If all of the above fails, you have a configuration problem at your local workstation, or a network problem.
9. If Dynamic IP Addressing is enabled try "hard coding" the printer IP address at the User Interface. Reset the printer, and check for connectivity again with the "ping" command.

NOTE

When using **lpr** to print jobs it is possible to set the lpr port to a port other than the default of 515. If this occurs, it will halt all lpr printing but printing using other protocols would still work.

10. If all of the above troubleshooting fails, you may have a malfunctioning Network Interface.

NetWare troubleshooting steps

This procedure assumes that the printer is turned on and, connected to a functioning network port with the correct cabling.

Obtain a Configuration Report from your printer.

1. Enter the **Tools** pathway.
 - a) Press the **Access** (**A** or ) button.
 - b) On the keypad enter **1111** or the current password. Press the **Enter** button when finished. The Touch Screen will be used for the remainder of the data entry, unless instructed otherwise.
 - c) Press the **Go to Tools** button.
 - d) Select **System Setting**.
 - e) Select **Configuration Report**.
 - f) Select **Print Configuration Report Now**.
 - g) Press the **Cancel** button.
 - h) Press the **Exit Tools** button.
2. Allow a minute for the Report to print.

3. Review the **NetWare Settings**: area of the page and verify at the User Interface these items:

Ethernet or **Token Ring** (depending on which is being used) is **ENABLED**.

Frame Type matches the frame type of the Primary fileserver.

Primary File Server (for NetWare 3.1X only) is set to the name of the server that serves the print queue you have assigned to the printer. Setting the Primary Server is extremely important on large networks.

NDS Tree (for NetWare 4.X and 5.X NDS only) is set for the correct **NDS tree name**.

NDS Context (for NetWare 4.X and 5.X NDS only) is set for the correct **NDS Context**.

Print Server Name is set for the name selected for this printer to act as a print server.

Print Server Password is set correctly for this print server.

4. Print out another **Configuration Report** page to verify the items you modified were set and retained.
5. **VERIFY** that the NetWare print queue assigned to the printer exists, is accepting jobs, and has a Print Server attached. If the printer has not logged in, reboot the printer.

NetBEUI Troubleshooting Steps

Obtain a Configuration Report from your printer.

1. Enter the **Tools** pathway.
 - a) Press the **Access** (**A** or ) button.
 - b) On the keypad enter **1111** or the current password. Press the **Enter** button when finished. The Touch Screen will be used for the remainder of the data entry, unless instructed otherwise.
 - c) Press the **Go to Tools** button.
 - d) Select **System Setting**.
 - e) Select **Configuration Report**.
 - f) Select **Print Configuration Report Now**.
 - g) Press the **Cancel** button.
 - h) Press the **Exit Tools** button.
2. Allow a minute for the Report to print.

3. Review the **NetBIOS:** area of the page and verify at the User Interface these items:

NetBEUI Protocol is Enabled.

Interface is set to **Ethernet / NetBEUI** or **Token Ring / NetBEUI** (depending on which is being used).

Host Name is set for the NetBEUI name selected for this printer.

Printer Name is set for the name selected for this printer to act as a print server.

WorkGroup: is set for the name of the desired NetBEUI workgroup for this printer.

Number Connections is **8** or greater.

Connection Timeout is between **100** and **9999**.

4. If any changes are made at the User Interface, exit the Tools menu to reset the printer.
5. Print out another **Configuration Report** page to verify the items you modified were set and retained.

OS/2 Troubleshooting Steps

Obtain a Configuration Report from your printer.

1. Enter the **Tools** pathway.
 - a) Press the **Access** (**A** or ) button.
 - b) On the keypad enter **1111** or the current password. Press the **Enter** button when finished. The Touch Screen will be used for the remainder of the data entry, unless instructed otherwise.
 - c) Press the **Go to Tools** button.
 - d) Select **System Setting**.
 - e) Select **Configuration Report**.
 - f) Select **Print Configuration Report Now**.
 - g) Press the **Cancel** button.
 - h) Press the **Exit Tools** button.
2. Allow a minute for the Report to print.
3. For OS/2 printing only, **VERIFY** that LPRPORTD.EXE is running.
4. For OS/2 and WIN-OS/2 printing, **VERIFY** that LPRMON.EXE is running.
5. Verify you have applied all appropriate IBM Fixpacks, APARs (see compatibility for required Fixpacks). If not, the proper Fixpack must be applied.
6. Check ALL IP addresses and verify that you have set the printers address correctly at the User Interface.
7. Go to a workstation and use the “ping” command to see if your server responds. If the server does not respond, you may have an addressing or network problem.

8. Use the “ping” command to see if your printer responds. If the printer does not respond, you may have an addressing or network problem. Correct these conditions by checking and resetting IP addresses or cabling and retry.
9. Use the “ping” command to see if your gateway responds. If the gateway does not respond, you may have an addressing or network problem. Correct these conditions by checking and resetting IP addresses or cabling and retry.
10. Check your router, subnet (if applicable), and gateway addresses. (Incorrect addressing can render your lpr/lpd printing system unusable.)

AppleTalk Troubleshooting Steps

This procedure assumes that the printer is turned on, and, connected to a functioning network port with the correct cabling.

Obtain a Configuration Report from your printer.

1. Enter the **Tools** pathway.
 - a) Press the **Access** (**A** or ) button.
 - b) On the keypad enter **1111** or the current password. Press the **Enter** button when finished. The Touch Screen will be used for the remainder of the data entry, unless instructed otherwise.
 - c) Press the **Go to Tools** button.
 - d) Select **System Setting**.
 - e) Select **Configuration Report**.
 - f) Select **Print Configuration Report Now**.
 - g) Press the **Cancel** button.
 - h) Press the **Exit Tools** button.
2. Allow a minute for the Report to print.

3. Review the **AppleTalk Settings:** area of the report and verify at the these items through the Tools menu:

AppleTalk Protocol is **Enabled**.

AppleTalk Interface is set to **Ethernet**.

AppleTalk Name is set for the name selected for this printer to act as a print server and that the entry is spelled correctly.

AppleTalk Zone is set for the zone selected for this printer and that the entry is spelled correctly.

4. Go to a workstation and **VERIFY** that the printer is visible in the Chooser.

This procedure assumes that the printer is turned on and connected to a functioning network port with the correct cabling.

Obtain a Configuration Report from your printer.

1. Enter the **Tools** pathway.
 - a) Press the **Access** (**A** or ) button.
 - b) On the keypad enter **1111** or the current password. Press the **Enter** button when finished. The Touch Screen will be used for the remainder of the data entry, unless instructed otherwise.
 - c) Press the **Go to Tools** button.
 - d) Select **System Setting**.
 - e) Select **Configuration Report**.
 - f) Select **Print Configuration Report Now**.
 - g) Press the **Cancel** button.
 - h) Press the **Exit Tools** button.
2. Allow a minute for the Report to print.
3. Review the **Banyan VINES** settings.
4. **User Name/PCPRINT** Destination entered at the UI should match the User Name and the PCPRINT Streetalk (ST) name created at the Server.
5. The **User Password** entered at the UI should match the Password entered for the User created at the Server.

6. The **Print Service** name entered at the UI should match the name of the Print Service created at the Server.
7. **PCPRINT** is the Destination configured for the Print Service at the Server.
8. If any changes are made at the User Interface the printer will reset.
9. Allow the printer approximately seven minutes to reboot.
10. Print out another **Configuration Report** page to verify the items you modified were set and retained.
11. Consult the table below for troubleshooting suggestions.

Printer busy Job reached the top of the queue and cannot print.	Check steps 3,4,5 above are Correct. Check the PC port setup with the SETPRINT command.
Paper Format NA	Job reached the top of the queue and an attempt to match the job format failed. Change either the jobs format or the format of the destination printer to print the job.
Rejected	Job is corrupted, or an internal occurred. Check or reinstall print drivers.
Cancelled	Job was removed from the queue. The queue configured timeout expired. Check queue configuration.

18. Network Accounting

Overview

The Document Centre when used in conjunction with Network Accounting solutions software or hardware, provides the ability to control access to, and monitor up to twenty networked Document Centres for the following functions:

Copying

Printing

Faxing

Scanning

With Network Accounting solutions you may set up user accounts, keep data on usage patterns, and track office expenses effectively using a single tool.

The network accounting application communicates with the Document Centre Web Server (Internet Services) to configure, and retrieve information from your Document Centre.

This procedure assumes that your network accounting hardware and software has already been installed, your Document Centre has had the required upgrade installed, and is properly connected to your network.

Before You Start

NOTE

Your Document Centre now has DHCP, LPR, and NetBIOS over the IP protocol enabled by default. If your DHCP server will provide host name, IP address, Gateway address, and Subnet Mask, the Document Centre TCP/IP information will be configured on initial boot.

Your printer and your network accounting solution software or server must be connected to a network which has the TCP/IP protocol enabled and all TCP/IP information such as hostname, Default Gateway and Broadcast address have been set.

Your Document Centre and network accounting solution server should be assigned TCP/IP addresses and the HTTP protocol must have been enabled at your Document Centre. If necessary, refer to the **Internet Services Quick Install Card** to configure your Document Centre in this manner.

If Dynamic TCP/IP addressing must be used, be sure to set lease times long enough to allow for normal maintenance shutdowns. If your Document Centre appears to have stopped communicating with the network accounting solution when Dynamic Addressing is in use, check the TCP/IP settings to be sure they have not changed.

As a quick test to verify all the requirements have been met, start the Web Browser from your network accounting solution server and enter the IP address of the Document Centre to see if you can communicate with it using the HTTP protocol. If the Browser connects and you can see the “Home Page” proceed to the next section entitled **Go to the Document Centre and...**

Go to the Document Centre and...

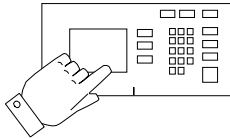

1. **Enter the Tools pathway.**
 - a) Press the **Access** (**A** or ) button.
 - b) On the keypad enter **1111** or the current password. Press the **Enter** button when finished. The Touch Screen will be used for the remainder of the data entry, unless instructed otherwise.
 - c) Press the **Go to Tools** button.
2. **Enter the Access and Accounting menus.**
 - a) Press the **Access and Accounting** button.
 - b) Press the **Authentication Mode** button.
3. **Enable Network Accounting.**
 - a) Press the **Network Accounting** button.
 - b) Press **Save** to retain the settings and continue.

4. **Perform the Network Accounting Setup.**
 - a) Press the **Network Accounting Setup** button.
 - b) Press the **Enabled** button.
 - c) Press the **Save** button to retain the settings.
 - d) Press the **Exit Tools** button.
5. **Verify Accounting is enabled.**
 - a) Press the **Job Status** button on the front panel then press the **Features** button.
 - b) The Touch Panel should display a screen with two buttons. One is the **User ID** button and the other is the **Account ID** button. This indicates the system has enabled accounting successfully.

Go to the network accounting server and...

1. **Activate the Document Centre.**
 - a) Open the application and configure it so that the TCP/IP address (or fully qualified domain name) of Document Centre is entered as the destination for retrieval of data.
2. Proceed to the next section of this procedure called **Go to the workstations and...**

Go to the workstation and...

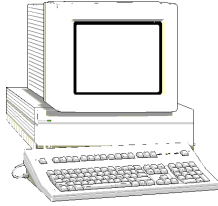

1. **Install Print drivers** (If print drivers have not already been installed, use the **CentreWare Network Services CD-ROM** to install print drivers. Details for this are found in the document supplied with your printer entitled **CentreWare Network Services Guide**) Workstations with existing Document Centre drivers must be upgraded to the new drivers to allow for printing when Network Accounting is enabled.
2. **Enable Accounting in the print driver.**
 - a) At your Windows 95/98/NT 4.0 desktop, click the **Start** button and select **Settings**.
 - b) From the cascade menu select **Printers**.
 - c) Select a printer with the right mouse button.
 - d) Select the **Properties** entry in the cascade menu.
 - e) Select the **User Preferences** tab on the Properties dialog.
 - f) Click the **Enable Accounting** checkbox.
 - g) If you do not want users to have to enter their User and Account ID each time they print, select the **Save Accounting Codes** checkbox.
 - h) If desired you may also select the **Conceal User ID** and **Conceal Account ID** checkboxes to have the asterisk (*) character echoed when this information is entered.
 - i) When finished making selections, click **OK** to close the driver and save the settings.

3. Test the accounting function of the driver.

- a) Open an application and print a job. Verify that you are presented with the User ID and Accounting ID screen.
- b) Enter a valid User and Accounting ID and click **OK** (If you selected **Save Accounting Codes** it will only necessary to enter this information the first time the driver is used).
- c) If your print job does not print, try to copy a job at the Document Centre using the same Account and User ID. If the copy job completes then the Account and User ID are valid.
- d) It may be necessary to check the network accounting solution software or server configuration to verify the proper User ID and Account ID.
- e) Repeat this **Go to the workstation and...** procedure for each workstation on the network that will print to the printer.

Network Accounting Troubleshooting

To be sure the Document Centre has had the Network Accounting option installed and enabled, start a Web Browser from your Network Accounting server and enter the IP address of the Document Centre.

NOTE

If you are not able to reach the printer, verify all TCP/IP information by printing a configuration sheet.

At the Document Centre "Home Page" select the **Services** button.

Verify that on the **Job Submission** screen, there are entries for **Login ID** and **Account ID**. This will indicate that accounting has been enabled.

The Network Accounting server software may contain some troubleshooting tools that are useful to diagnose problems that may be present at the server. These tools can be used to correct configuration or communication problems that will prevent your Document Centre from reporting accounting data.

For detailed information on these tools, consult your Network Accounting Solutions documentation.

For general product and feature information visit the vendor website or consult the software documentation.

19. Network Fax

Overview

A network Fax Server/software solution provides the ability to fax paper documents from your Document Centre as well as modify, forward, and distribute electronic copies of documents to other Fax devices or to user workstations.

This procedure assumes the following:

- Your network Fax Server/software solution has already been installed.
- Your Document Centre is installed on your network as a printer, and your Document Centre has the fax option installed that will allow it to send fax documents to a fax repository (destination directory).
- You want to send faxes by FTP (File Transfer Protocol) using the TCP/IP protocol or by NCP(IPX) to the repository.

If you want your Document Centre to send fax documents to a Novell NetWare server Fax Repository, refer to the next section of this document entitled **Fax Installation for IPX/SPX**.

FAX Installation for FTP

Before You Start

NOTE

Your Document Centre now has DHCP, LPR, and NetBIOS over the IP protocol enabled by default. If your DHCP server will provide host name, IP address, Gateway address, and Subnet Mask, the Document Centre TCP/IP information will be configured on initial boot.

Your Document Centre and your network Fax Server/software solution must be connected to a network which has the TCP/IP protocol enabled. Additionally, record TCP/IP information such as Hostname, TCP/IP Address, and Default Gateway for both the network Fax Server solution and your Document Centre.

It is strongly recommended your network Fax Server is assigned a static IP address. If necessary, refer to the **Static (Manual) TCP/IP Addressing Quick Install Card** contained in this card set to configure your Document Centre in this manner.

Dynamic IP Addressing may be used for the network Fax Server/software solution provided the DHCP server has been configured with sufficient lease time so that the server normal maintenance and service down times will not result in a change in TCP/IP address.

An account must be created on the server to which the Document Centre will FTP the fax documents that has sufficient rights or permissions to allow the Document Centre to read files, write files, delete files, and create new directories. Anonymous FTP logins will not allow these rights. Record the login name, home directory, and password of this account for use during this procedure.

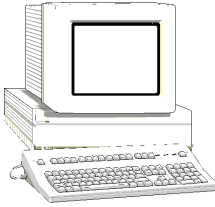

1. Open your Web browser and enter the TCP/IP address of the Document Centre in the Address or Location field.
2. Click the **Properties** tab or click **Properties** in the directory tree.
3. Select **Services**, then select **Distribution Templates** in the directory tree.
4. Select **Repository Setup** in the directory tree.
5. Select **Fax Repository 0** from the **Repository List** drop-down list.

The screenshot shows the CentreWare Internet Services web interface. The top navigation bar includes 'services', 'jobs', 'status', 'properties', 'maintenance', and 'support'. The left sidebar shows a directory tree with 'Properties' expanded to 'Distribution Templates' and 'Repository Setup' selected. The main content area is titled 'Distribution Templates' and 'Repository Setup'. It features a 'TCP/IP Settings' section with a 'Repository List' dropdown menu set to 'Fax Repository 0'. The 'Protocol' is set to 'TCP/IP'. The 'File Server IP Address' is entered as '0.0.0.0:21'. There are input fields for 'Directory Path', 'Login Name', 'Password', and 'Retype password'. At the bottom of the settings section are two buttons: 'Apply New Settings' and 'Restore Settings'. The footer contains 'THE DOCUMENT COMPANY XEROX' and 'Copyright © 2000 Xerox Corporation. All rights reserved.' along with a 'Help' icon.

6. Select TCP/IP for **Protocols**.
7. Type the IP Address of the File Server.
8. Type the Directory path where the files will be stored.
9. Type the **Login Name** and **Password** for the repository. Retype the password to verify it in **Retype Password**.
10. Click **Apply New Settings** to accept the changes or **Restore Settings** to return the settings to their previous values.

Go to the FAX server and...

1. **Set the Fax server options for receiving Document Centre fax documents** (Refer to the documentation provided with your server).
2. Prepare for print driver installation
 - a) From the documentation package supplied with your printer, retrieve the **CentreWare Network Services CD-ROM** and the document entitled **CentreWare Network Services Guide**. Proceed to the next section of this procedure called **Go to a Workstation and...**

Go to the workstation and...

1. **Install the new upgraded CentreWare print drivers**
 - a) Use the **CentreWare Network Services CD-ROM** and the instructions in the document entitled **CentreWare Network Services Guide** to install the print driver for your operating system.
 - b) Test your installation by opening an application and print a test fax document and verify its receipt.

If your fax document does not reach its destination refer to the troubleshooting information in the Fax server documentation.

Before You Start

Your Document Centre and your Fax server must be connected to a network which has the Novell NetWare server which contains the Fax Repository.

An account must be created on the NetWare server to which the Document Centre will send the fax documents. This account must have sufficient rights or permissions to allow the Document Centre to read files, write files, delete files, and create new directories. Record the NDS Tree (if applicable), Context (if applicable) login name, Server Volume, home directory, and password of this account for use during this procedure.

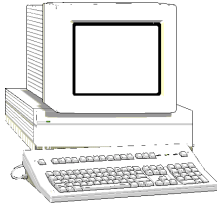

1. Open your Web browser and enter the TCP/IP address of the Document Centre in the Address or Location field.
2. Click the **Properties** tab or click **Properties** in the directory tree.
3. Select **Services**, then select **Distribution Templates** in the directory tree.
4. Select **Repository Setup** in the directory tree.
5. Select **Fax Repository 0** from the **Repository List** drop-down list.

The screenshot shows the 'CentreWare Internet Services' web interface. The 'Document Centre' is selected, and the 'Properties' tab is active. The left-hand directory tree shows 'Services' > 'Distribution Templates' > 'Repository Setup' selected. The main content area is titled 'Distribution Templates' and 'Repository Setup'. Under 'NetWare Settings', the 'Repository List' dropdown is set to 'Fax Repository 0'. The 'Protocol' is set to 'NetWare' (selected with a radio button). Below are several empty text input fields for 'Server Name', 'Server Volume', 'NDS Context', 'NDS Tree', 'Directory Path', 'Login Name', 'Password', and 'Retype password'. At the bottom of the form are two buttons: 'Apply New Settings' and 'Restore Settings'. The footer of the page includes 'THE DOCUMENT COMPANY XEROX' and 'Copyright © 2000 Xerox Corporation. All rights reserved.' along with a 'Help' icon.

6. Select NetWare for **Protocols**.
7. Type the name of the repository server in **Server Name**.
8. Type the name of the server volume (NetWare 3.x, 4.x, 5.x (*IPX only*)) in **Server Volume**.
9. Type the context and tree (NetWare 4.x, 5.x (*IPX only*)) for the repository in **NDS Context** and **NDS Tree**.
10. Type the path for the repository in **Directory Path**.
11. Type the **Login Name** and **Password** for the repository. Retype the password to verify it in **Retype Password**.
12. Click **Apply New Settings** to accept the changes or **Restore Settings** to return the settings to their previous values.

Go to the Fax server and...

1. **Set the Fax server options for receiving Document Centre fax documents** (details for these procedures are available in the documentation provided with your Fax server)
 - a) Add the path and home directory of the Fax Repository that will be monitored by the Fax server.
 - b) From the documentation package supplied with your printer, retrieve the **CentreWare Network Services CD-ROM** and the document entitled **CentreWare Network Services Guide**. Proceed to the next section of this procedure called **Go to a Workstation and...**

Go to the workstation and...

1. **Install the new upgraded CentreWare print drivers**
 - a) Use the **CentreWare Network Services CD-ROM** and the instructions in the document entitled **CentreWare Network Services Guide** to install the print driver for your operating system.
 - b) Test your installation by opening an application and print a test fax document and verify its receipt.

If your fax document does not reach its destination refer to the troubleshooting information in the Fax server documentation.

TCP/IP (FTP) Troubleshooting

1. Fax a document from the Document Centre. Observe the fax repository directory to watch for documents that have been faxed. If documents are able to reach this directory, the FAX server should be checked to make sure the Workserver is configured to Enable DCS Interface and the path for the repository is set correctly. Consult the FAX server documentation for details on how to configure the Workserver.
2. Verify that the TCP/IP information configured at the Document Centre is correct.
3. Verify that **FTP** is configured as the filing protocol in the **Fax Repository Settings** screen of the Document Centre Tools pathway.
4. Verify that the **Login** and **Password** shown in the **Fax Repository Settings** screen of the Document Centre Tools pathway are correct (these are CASE SENSITIVE).
5. Verify that the **Path** entry is correct in the **Fax Repository Settings** screen of the Document Centre Tools pathway.
6. At the FAX server, verify that the user Login name and password created for the Document Centre are correct and have sufficient rights (permissions) to write files, and create directories in the fax repository. Be aware that the default settings for the (IIS) Internet Information Server FTP server do not allow write permission. You may check this in the FTP server Properties dialog.
7. Test the server settings with an FTP programme. Connect to the server TCP/IP address and login with the Login Name and Password that was set for the Document Centre. Verify that you are in the path directory that was configured.
8. Create a directory. If you can create a directory, then the account has sufficient permissions to fax documents to that directory. If you cannot create a directory, adjust the permissions for the account.

NetWare (IPX/SPX) Troubleshooting

1. Fax a document from the Document Centre. Observe the fax repository directory to watch for documents that have been faxed. If documents are able to reach this directory, the FAX server should be checked to make sure the path for the repository is set correctly. Consult the FAX server documentation for details on how to configure this Workserver.
2. Verify that **NetWare** is set in the **Fax Repository Settings** screen of the Document Centre Tools pathway.
3. Verify that the **Login** and **Password** shown in the **Fax Repository Settings** screen of the Document Centre Tools pathway are correct (these are CASE SENSITIVE).
4. Verify that the **Path** entry is correct in the **Fax Repository Settings** screen of the Document Centre Tools pathway.
5. Verify that the **Server Name** entry is correct in the **Server and Volume** screen of the Document Centre Tools pathway.
6. Verify that the **Server Volume** entry is correct in the **Server and Volume** screen of the Document Centre Tools pathway.
7. For NetWare 4.X, 5.X ONLY, verify that the **NDS Context** entry is correct in the **NDS Settings** screen of the Document Centre Tools pathway.
8. For NetWare 4.X, 5.X ONLY, verify that the **NDS Tree** entry is correct in the **NDS Settings** screen of the Document Centre Tools pathway.
9. From a workstation on the network, login to the fax repository server with the Login Name and Password specified for your Document Centre. Verify that you are in the correct directory and if not, modify the user settings with SYSCON or NWADMIN to include the correct volume, path, and directory.
10. Create a directory in the path. If you cannot create a directory, modify the user settings with SYSCON or NWADMIN to grant rights to the correct volume, path, and directory.

20. Scan Setup without CentreWare

Introduction

Xerox brings the versatility of network scanning to your workstation. By combining the power of the Xerox Document Centre, Internet Services, and third-party applications, Xerox provides a network scanning solution for all scanning users.

After the optional Scanning Services kit is installed on the Xerox Document Centre, you can select scanning features, scan documents, and transfer them to a file server. The document can then be accessed from your workstation or shared with other users connected to the network, if desired. The document can be opened by any software application that can view or edit TIFF files. For example, Visioneer PaperPort, which is included on a CD ROM with your Document Centre when you purchase the Scanning Services option can view and edit TIFF files.

The scanned images can also be imported into TextBridge Pro for Optical Character Recognition (OCR) processing.

Terminology used in this Chapter

Document Repository	A Document Repository is a filing directory where TIFF or PDF files are stored. Typically, this will be located on a NetWare server or FTP (File Transfer Protocol) server.
Scan Template	A Scan Template controls the features applied to the scanned document as well as the Filing Policy and repository location.
Template Pool	The Template Pool is the central location on a server where scan templates created with Xerox's CentreWare Scanning Services are stored.
Filing Policy	The Filing Policy specifies the method used to store the TIFF or PDF images in the document repository. There are several options: <ul style="list-style-type: none">• Overwrite Existing File• Append to Existing File• Do Not Save• Rename New File
Output Image Format	<ul style="list-style-type: none">• TIFF• Multi-Page TIFF• Image Only PDF

Who Should Use This Guide

This chapter is a companion to the **Network Scanning Services Guide** and is intended to be used by System Administrators who are setting up network scanning without using CentreWare Network Scanning Services. CentreWare Network Scanning Services is intended for use on Windows based workstations.

There are two other options for setting up scanning services:

- Setting up Native Scanning
- Setting up Scanning Using CentreWare Internet Services

Both of these set up options require the use of procedures in this guide. For Setting up Scanning Using CentreWare Internet Services, you will need to complete some processes, and then refer to the **Internet Services Guide** to complete the set up. All of the procedures for setting up Native Scanning are included in this section.

There are two options for file transfer if you are setting up Native Scanning or Scanning Using CentreWare Internet Services.

- Setting Up Scanning - NetWare (NCP)
- Setting Up Scanning - FTP (File Transfer Protocol)

Procedures for both of these file transfer options are contained in this guide.

NOTE

If you will be using Xerox's CentreWare Network Scanning Services to set up scanning on the Document Centre, refer to the **Network Scanning Services Guide** guide now.

To use the procedures in this guide effectively, you must have experience working in a network environment. You must also have access to the network and possess Supervisor (Administrator) rights. You may also require documentation provided by network and client workstation vendors.

What to Do Next

To complete the setup of the Document Centre and your network to enable scanning, perform the following steps.

1. Review the information in the **Scanning Overview** section of this chapter. Read the entire overview, including the **Overview of Repositories**.
2. Refer to the appropriate section of this guide. Choose from:
 - **Set Up Scanning - NetWare**. NCP (NetWare Core Protocol) is available for Ethernet and Token Ring filing to a NetWare server.
 - **Set Up Scanning - FTP (File Transfer Protocol)**. FTP is available for Ethernet and Token Ring (if installed) and requires an FTP server running on a server or a workstation.
3. **OPTIONAL**: If you are using Xerox CentreWare Internet Services to perform network scanning, refer to the **Internet Services Guide**.

Scanning Overview

Scanning a document has traditionally involved a dedicated scanner attached to a single PC. In this environment, a single user at the PC has access to the scanner. Other users cannot scan documents without interrupting the person using the scanner and PC. This is inconvenient and inefficient.

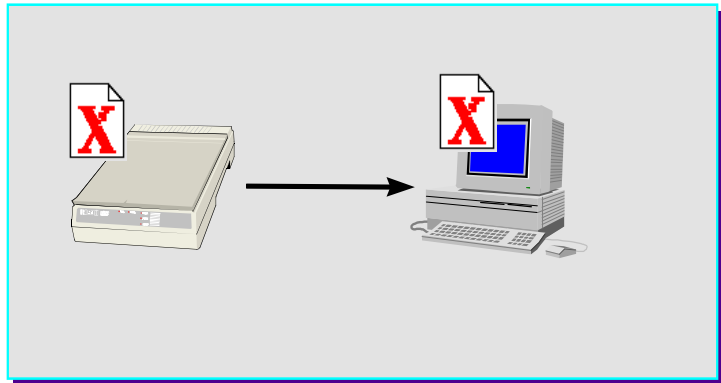

Traditional Scanning

Scanning with the Document Centre

Using the Document Centre, multiple users can scan and store documents without multiple scanning devices. Using the power of the local area network, multiple users can access the scanner and use it to scan their documents.

Scanning with the Document Centre is accomplished through the use of a *file server*. The file server is used as a temporary storage location for the scanned document file. After scanning and storage on the file server, the file can be manually retrieved by a user at a network workstation.

NOTE

Automatic retrieval of the scanned document to a workstation is possible using Xerox's CentreWare Network Scanning Services. Refer to the **Network Scanning Services Guide** for more information.

A "dedicated file server" is not required. The Document Centre can store documents on an existing file server.

To perform network scanning, the Document Centre is installed on a local area network. The protocol of the local area network must be NetWare SPX/IPX or TCP/IP. For the user to retrieve the scanned document file, it must be transferred to a file server. The scanning and filing of the document are controlled by a scanning component called a *scan template*.

Scan Templates

The scan template is essentially a job ticket for the scanned job. The template is user-programmable, and contains parameters for the scanned document. The user can programme parameters such as one-sided or two-sided scanning, scanned image size, and the location on the file server where the file will be stored.

The Default Template

A default scan template (*default.xst*) is created during the installation of the scanning option and is stored on the Document Centre. It is available for all scanning installations.

It is selected at the Document Centre Control Panel Touch Screen to begin the scanning process.

NOTE

The Native scanning installations described in this guide provide only the *default.xst* template for all scanning users.

In this environment, additional scan templates can easily be created using only Xerox's CentreWare Internet Services, or the Xerox Network Scanners Utility. You **MUST** refer to the **Internet Services Guide** to create templates with Internet Services, or the **Network Scanning Services Guide** to use the CentreWare Template Utility.

The Scanning Process

Under the control of the instructions in the scan template, the Xerox Document Centre can scan hard copy documents and create electronic Tagged Image File Format (TIFF) or Portable Document format (PDF) files.

Using the filing information that is contained in the template, the TIFF/PDF file or files are transferred to a *document repository* on the file server. The document repository is simply a directory on the file server.

All pages of a multi-page document are scanned prior to the job being sent to the document repository.

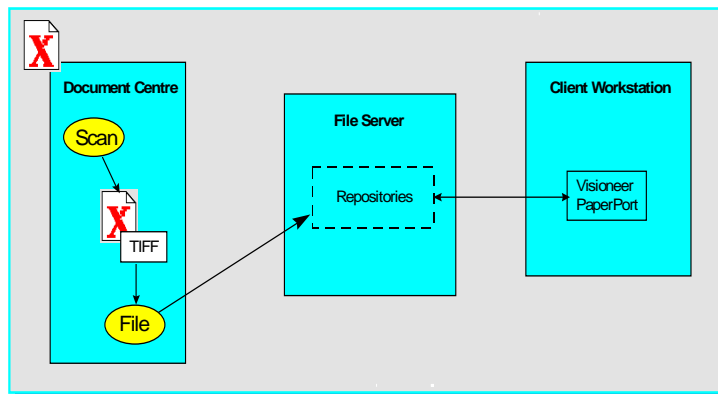

Scanning Process

After the scanned document files are sent to the file server, the user can retrieve the files from a network workstation.

The three main steps involved in scanning a job are:

1. **Scan a hard copy document at the Document Centre.**
Select a scan template from the Control Panel Touch Screen and scan the hard copy document at the Document Centre. Scan templates define the Directory and the Document Folder on the server where the scanned file will be stored.

2. **The scanned files are sent to a specified location on the file server.**

After pages have been scanned and converted to TIFF 6.0 or PDF files, the Document Centre logs into an account on the file server and stores the files in a specific directory (the document repository) on the file server. As with any user account, access to the file server is controlled by a user name and password.

To name and store the files, a numbering scheme (such as 00000001.TIF, 00000002.TIF, 00000003.TIF) is applied to each file. The Document Centre then logs out of the server.

NOTE

During the transfer of the file in a NetWare environment, the Document Centre will be already logged in under one license as a printer, and will log in again to transfer the file. After transfer occurs, the Document Centre logs out, making the second user license available again. While available to other users, the second connection is maintained at the NetWare file server as “Not logged in”. This happens during every scan job. If a license is not available, the file transfer will fail and the Document Centre will not retry the operation. If this occurs, the scan job will have to be run again when a license becomes available.

NOTE

The method used at a workstation to access the document repository and the method used at the Document Centre to send the documents are independent. For instance, the Document Centre may file the images using FTP (File Transfer Protocol) to an NT Server; while the workstation may retrieve the images using NetBIOS/NetBEUI.

3. **A user retrieves the files.**

The user manually retrieves the files and can then manipulate the electronic file as desired. For example, Visioneer PaperPort, which is included on the Scanning Services option can view and edit TIFF files.

PaperPort has an intuitive interface that enables you to annotate, organise, file, and locate scanned documents. Using PaperPort links, you can transfer documents from the PaperPort desktop to other applications and devices installed on your workstation.

Overview of Repositories

NOTE

Repositories may only be created with CentreWare Internet Services through your Web Browser. For details on how to use Internet Services to create Templates and Repositories, refer to the document supplied with your Document Centre entitled **Internet Services Guide**.

Public Repositories

Public repositories can be selected by all users as the destination for their scanned files.

The scan template for a public repository includes the name and the password required for access to the repository.

When this scan template is selected at the Document Centre, the name and password will not have to be entered because the name and password are already contained in the scan template. Be sure to read the *Repository Filing Policy* information on the next page. The **Overwrite** Filing Policy allows previously scanned jobs in the directory to be overwritten. This might be an inappropriate Filing Policy choice for a public repository.

Repository Filing Policy

NOTE

Filing Policies are only supported when scan templates are created with CentreWare Internet Services through your Web Browser. For details on how to use Internet Services to create Templates and filling policies, refer to the document supplied with your Document Centre entitled **Internet Services Guide**.

The *Filing Policy* specifies the method used to store the images in the document repository. There are several options:

- The **Overwrite Existing File** Filing Policy deletes any files stored in the document repository before sending the newly scanned files for storage. All overwritten files are lost, but since the files are overwritten, disk space is conserved.
- The **Append to Existing File** Filing Policy does not delete existing files. Newly scanned files are added to existing files in the document repository. It is recommended that you delete old files on a regular basis in order to conserve server space.
- The **Do Not Save** Filing Policy checks to see if any files already exist in the document repository. If there are no files in the repository, the newly scanned files are sent to it. If there are files stored in the repository, the scan job is aborted.
- The **Rename New File** Filing Policy creates a new directory structure, based on the time and date of creation, into which the images are filed. While this may seem like the safest Filing Policy choice, keep in mind that it also requires more disk space than the Overwrite Filing policy.

Output Image Quality

- **Multi-Page TIFF** can be enabled using Xerox CentreWare Internet Services. When Multi-Page TIFF is enabled, a single TIFF file will be created for a multi-page document. This single TIFF file will contain all the pages of the document. An .XSM folder is not created when scanning in the Multi-Page TIFF mode. A single TIFF file and a log file (.xst) are stored in the repository for each multi-page document that is scanned.

CAUTION

Not all applications will accept the Multi-Page TIFF format. Applications that do not support Multi-Page TIFFs will typically import and display only the first page of the document.

Repository Locking

More than one Document Centre can log into a file server and transfer a file to the same document repository, but *not at the same time*.

When one Document Centre logs in to transfer a file, the document repository is locked. Another Document Centre cannot transfer a file to the repository. This prevents possible corruption of the files.

Multiple Logins

More than one Document Centre can transfer files to *different repositories* in the same file server at the same time. This is similar to more than one user logging into a file server at the same time to transfer files to different directories.

Existing Accounts

A Document Centre can use an existing user account if the account is enabled for multiple logins. The account for the scanner is no different from a user account. *It is a user account!*

Logging in to Multiple File Servers

The same Document Centre can log into more than one file server and transfer a file to a document repository, *but not at the same time.*

This is similar to a user logging into more than one file server. The scanner requires accounts in all file servers that it needs to access.

Set Up Scanning - NetWare

Before You Start

Prior to starting the installation procedure, perform the following:

1. Ensure that the Document Centre is connected, configured, and operating correctly as a printer.
2. Use the SYSCON utility for NetWare 3.x, or NWADMIN for NetWare 4.x to create a user account on the file server for the scanner.
3. Create a directory on the file server to be used as a repository for scanned files. Give the scanner user account all access rights to this directory, except supervisor. The repository name cannot exceed 8 characters.

NOTE

Refer to the NetWare documentation for additional information.

When a document is scanned, the Document Centre logs into the scanner user account with the user name and password, transfers the file to the repository in the server, and then logs out.

NOTE

The Document Centre supports TIFF and PDF File Formats.

There are two procedures that can be used to successfully set up scanning. Read the information below and choose the procedure that you will use to complete the installation:

- **Set up scanning**
To complete the native implementation of scanning for your NetWare environment, go to the section of this chapter titled *Set Up Scanning* now.
- **Use Xerox CentreWare Internet Services**

Xerox's CentreWare Internet Services is accessed through the embedded HTTP server on the Document Centre that allows System Administrators and users to configure scan settings. This is accomplished by using an Internet browser such as NetScape (version 3.x or later) or Microsoft Internet Explorer (version 4.x or later).

Using Internet Services, you can:

- Create new scan templates.
- Update existing scan templates.
- Modify scan configurations (including document repository locations), enable and disable Confirmation Sheets, and change Filing Protocols.
- Enable Multi-Page TIFF, which will create a single TIFF file for a multi-page document, instead of one TIFF file for each page.

Output Image Quality

- *Multi-Page TIFF* can be enabled using Xerox CentreWare Internet Services. When Multi-Page TIFF is enabled, a single TIFF file will be created for a multi-page document. This single TIFF file will contain all the pages of the document. An .XSM folder is not created when scanning in the Multi-Page TIFF mode. A single TIFF file and a log file (.xst) are stored in the repository for each multi-page document that is scanned.

CAUTION

Not all applications will accept the Multi-Page TIFF format. Applications that do not support Multi-Page TIFFs will typically import and display only the first page of the document.

If you will be using CentreWare Internet Services to complete the installation, perform these steps.

- A. Refer to the chapter entitled **Internet Services** in this document.
- B. Follow the instructions located in the section of this chapter entitled **Set up Scanning**.
- C. Finally, refer to the section entitled **Scanning Documents** of the **Internet Services Guide**, and follow the instructions there.

General Installation Requirements

Item	Purpose	Provided by
Document Centre Scanning Services kit	This kit must be installed before proceeding with the installation steps in this chapter.	Xerox
Scan User Name	When a document is scanned, the Document Centre logs in to the user account with the user name and password, transfers the file to the server, and then logs out.	Customer
Scan User Password	When a document is scanned, the Document Centre logs in to the user account with the user name and password, transfers the file to the server, and then logs out.	Customer
File Repository Server	The hard copy document is scanned by the Document Centre and saved electronically in a designated file server repository.	Customer
Repository Directory	Repositories are directories or filing destinations where documents are stored and held in .XSM (Xerox document storage) format folders. The default folder name is DOC.XSM. A repository name cannot exceed 8 characters.	Customer
NDS Tree	<ul style="list-style-type: none">• For an NDS installation, assign the Document Centre to an NDS Tree.• For a Bindery installation, set the NDS Tree to a dash - to disable NDS.	Customer
NDS Context	<ul style="list-style-type: none">• For an NDS installation, assign the Document Centre to an NDS Name Context.• For a Bindery installation, set the NDS Context to a dash - to disable NDS.	Customer

Set Up Scanning (NetWare)

1. Open your Web browser and enter the TCP/IP address of the Document Centre in the Address or Location field.
2. Click the **Properties** tab or click **Properties** in the directory tree.
3. Select **Services**, then select **Distribution Templates** in the directory tree.
4. Select **Repository Setup** in the directory tree.
5. Select a repository from the **Repository List** drop-down list.

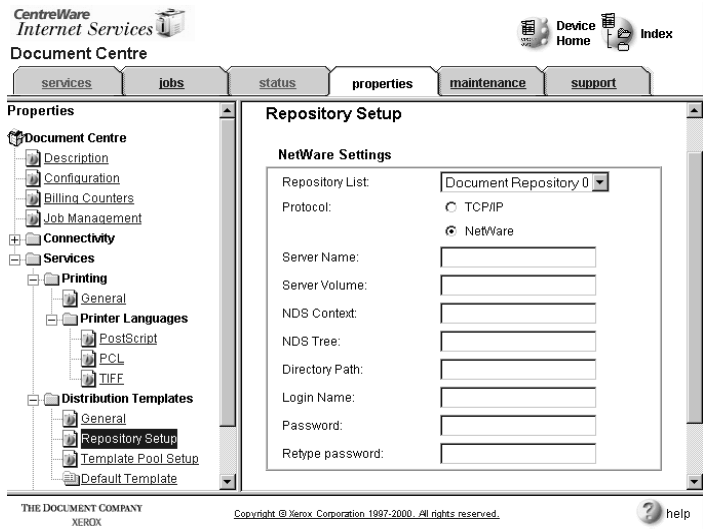

6. Select NetWare for **Protocols**.
7. Type the name of the repository server in **Server Name**.
8. Type the name of the server volume (NetWare 3.x, 4.x, 5.x (*IPX only*)) in **Server Volume**.
9. Type the context and tree (NetWare 4.x, 5.x (*IPX only*)) for the repository in **NDS Context** and **NDS Tree**.
10. Type the path for the repository in **Directory Path**.
11. Type the **Login Name** and **Password** for the repository. Retype the password to verify it in **Retype Password**.

12. Click **Apply New Settings** to accept the changes or **Restore Settings** to return the settings to their previous values.

NOTE

Refer to the information displayed by NWADMIN and the NetWare documentation for help in determining the name of the NDS Tree and Context.

NOTE

It is recommended that you install the Visioneer PaperPort software, which is shipped on a CD ROM and included with your Document Centre when you purchase Scanning Services. This software should be installed at each client workstation.

PaperPort allows you to annotate, organise, file and locate scanned documents. After you scan a document at the Document Centre, you can access PaperPort and retrieve the scanned file within the PaperPort application. With PaperPort links, you can transfer documents between the PaperPort desktop and other applications and devices on your workstation.

PaperPort contains links to several types of applications and devices, including:

- electronic fax applications
- electronic mail (“E-Mail”) applications
- optical character recognition (“OCR”) applications
- printers
- personal information managers (“PIM”)
- document control systems.

Test scanning

- A. Place the document that you want to scan in the Document Feeder, or place the first page on the Document Glass.
- B. Select the **Scan** feature on the Document Centre Touch Screen.
- C. Scan jobs are based on templates that contain programming selections for your job. Verify that **default.xst** is highlighted in the scan template list. This is the default template.
- D. If desired, select **More Scanning Features** and modify the template by selecting options from the *Scan Setups* tab on the Document Centre Touch Screen. Note that any changes you make from the Touch Screen apply only to the current job. The template settings will be restored after the completion of the scan job.
- E. Press the **Start** button. After the job is scanned, the Document Centre files, faxes, and prints the job as specified in the default.xst scan template. At completion, a Confirmation Sheet (if enabled) is printed that describes the results of the job.
- F. Allow approximately one minute for the process to complete a one-page job. It will take longer if you have scanned multiple pages. Then check to make sure that the scanned file has been stored in the designated repository on the file server.
- G. The Document Centre creates a separate file for each page it scans. (Unless the Enable Multi-Page TIFF option is selected, which will create a single TIFF file for a multi-page document, instead of one TIFF file for each page.) Pages are numbered sequentially. Files are stored on the file server, and the directory path is specified within the job template.

NOTE

If the scanning operation is not successful, check the Confirmation Sheet for a message or other information that may be helpful in identifying the cause of the problem.

- H. The scanned file is transferred to a folder in the scanner account on the file server. The *.XSM* extension on the folder represents a Xerox document storage format that is designed to simplify integration with third-party software applications.
- I. At your workstation, view or list the directory path for the scanner account on the file server. The scanning operation created a folder named *DOC.XSM*
- J. Open the *DOC.XSM* folder. You should see several files in this folder:

00000001.TIF ...00000002.TIF for example, are the individual TIFF images of the pages that were scanned. There can be several TIFF files if the document has more than one page, or if **Append** was selected for the *Filing Policy* and more than one document has been scanned.

Each page of the document is represented by a different TIFF file. (Unless the Enable Multi-Page TIFF option is selected, which will create a single TIFF file for a multi-page document, instead of one TIFF file for each page.)

NOTE

The Document Centre supports TIFF File Formats.

NETSCAN.DAT is an ASCII file which contains the names of the TIFF files scanned with the last scanning operation. This file is updated after every successful storage of a .TIF file.

NEXTNAME.DAT is an ASCII file which contains the name of the next available .TIF file. This name is controlled and incremented based on the Filing Policy specified in the job template.

NETSCAN.XST contains the template information for the last file that was scanned. It is also used as a job log for status and a source for the post-processing of information.

XSMDESC.DAT is an ASCII file containing the document name (0-50 characters).

- K. At this point, the file can be imported into any software application.
- L. Scanning is now ready to operate. Subsequent scanning operations can be modified by changing the selections in the Default Template using the Document Centre Touch Screen.
- M. The installation process is now complete.

Set Up Scanning - FTP (File Transfer Protocol)

Before you start

Prior to starting the installation procedure, perform the following:

1. Ensure that the Document Centre is connected, configured, and operating correctly as a network printer.
2. Ensure that FTP Services are running on a platform on the network. If FTP Services is running on a Windows NT server, ensure that **Allow Only Anonymous Connections** is NOT selected.
3. Create a user account for the scanner.

If the account is created on a Windows NT server, select **User Cannot Change Password** and **Password Never Expires** when the password is set, and select **Logon Locally** under User Rights.

4. Create a directory to be used as a repository for scanned files.

If the directory is created on a Windows NT server, enter the scan user name in the Alias box and select **Access Read and Write**.

Set up options

There are two procedures that can be used to successfully set up scanning. Read the information below and choose the procedure that you will use to complete the installation:

- **Set Up Scanning**
To complete the native implementation of scanning for your network environment, go to the section of this chapter titled *Set Up Scanning* now.
- **Use Xerox CentreWare Internet Services**

Xerox's CentreWare Internet Services is accessed through the embedded HTTP server on the Document Centre that allows System Administrators and users to configure scan settings. This is accomplished by using an Internet browser such as NetScape (version 3.x or later) or Microsoft Internet Explorer (version 4.x or later).

Using Internet Services, you can:

- Create new scan templates
- Update existing scan templates
- Modify scan configurations (including document repository locations) enable and disable Confirmation Sheets, and change Filing Protocols.
- Enable Multi-Page TIFF, which will create a single TIFF file for a multi-page document, instead of one TIFF file for each page.

Output Image Quality

- *Multi-Page TIFF* can be enabled using Xerox CentreWare Internet Services. When Multi-Page TIFF is enabled, a single TIFF file will be created for a multi-page document. This single TIFF file will contain all the pages of the document. An .XSM folder is not created when scanning in the Multi-Page TIFF mode. A single TIFF file and a log file (.xst) are stored in the repository for each multi-page document that is scanned.

CAUTION

Not all applications will accept the Multi-Page TIFF format. Applications that do not support Multi-Page TIFFs will typically import and display only the first page of the document.

If you will be using CentreWare Internet Services to complete the installation, perform these steps.

- A. Refer to the chapter entitled **Internet Services** in this document.
- B. Follow the instructions located in the section of the chapter entitled **Configure your printer**.
- C. Finally, refer to the section entitled **Scanning Documents** of the **Internet Services Guide**, and follow the instructions there.

General Installation Requirements

Item	Purpose	Provided by
Document Centre Scanning Services kit	This kit must be installed before proceeding with the installation steps in this chapter.	Xerox
Scan User Name	When a document is scanned, the Document Centre logs in to the user account with the user name and password, transfers the file to the server, and then logs out.	Customer
Scan User Password	When a document is scanned, the Document Centre logs in to the user account with the user name and password, transfers the file to the server, and then logs out.	Customer
File Repository Server	The hard copy document is scanned by the Document Centre and saved electronically in a designated file server repository.	Customer
Repository Directory	Repositories are directories or filing destinations where documents are stored and held in .XSM (Xerox document storage) format folders.	Customer

Set up scanning (TCP/IP)

1. Open your Web browser and enter the TCP/IP address of the Document Centre in the Address or Location field.
2. Click the **Properties** tab or click **Properties** in the directory tree.
3. Select **Services**, then select **Distribution Templates** in the directory tree.
4. Select **Repository Setup** in the directory tree.
5. Select a repository from the **Repository List** drop-down list.

CentreWare
Internet Services

Document Centre

services jobs status **properties** maintenance support

Properties

Document Centre

- Description
- Configuration
- Billing Counters
- Job Management
- Connectivity
- Services
 - Printing
 - Printer Languages
 - General
 - PostScript
 - PCL
 - TIF
 - Distribution Templates
 - General
 - Repository Setup**
 - Template Pool Setup
 - Default Template
 - Machine Software
 - Internet Messaging
 - Authentication Server

Distribution Templates

Repository Setup

TCP/IP Settings

Repository List: Document Repository 0

Protocol: TCP/IP NetWare

File Server IP Address: 0 0 0 21

Directory Path: _____

Login Name: _____

Password: _____

Retype password: _____

Apply New Settings

Restore Settings

THE DOCUMENT COMPANY XEROX Copyright © Xerox Corporation 1997-2000. All rights reserved. help

6. Select TCP/IP for **Protocols**.
7. Type the IP Address of the File Server.
8. Type the Directory path where the files will be stored.
9. Type the **Login Name** and **Password** for the repository. Retype the password to verify it in **Retype Password**.
10. Click **Apply New Settings** to accept the changes or **Restore Settings** to return the settings to their previous values.

NOTE

PaperPort allows you to annotate, organise, file and locate scanned documents. After you scan a document at the Document Centre, you can access PaperPort and retrieve the scanned file within the PaperPort application. With PaperPort links, you can transfer documents between the PaperPort desktop and other applications and devices on your workstation.

PaperPort contains links to several types of applications and devices, including:

- electronic fax applications
- electronic mail (“E-Mail”) applications
- optical character recognition (“OCR”) applications
- printers
- personal information managers (“PIM”)
- document control systems.

Test scanning

- A. Place the document that you want to scan in the Document Feeder, or place the first page on the Document Glass.
- B. Select the **Scan** feature on the Document Centre Touch Screen.
- C. Scan jobs are based on templates that contain programming selections for your job. Verify that **default.xst** is highlighted in the scan template list. This is the default template.
- D. If desired, select **More Scanning Features** and modify the template by selecting options from the *Scan Setups* tab on the Document Centre Touch Screen. Note that any changes you make from the Touch Screen apply only to the current job. The template settings will be restored after the completion of the scan job.

- E. Press the **Start** button. After the job is scanned, the Document Centre files, faxes, and prints the job as specified in the default.xst scan template. At completion, a Confirmation Sheet (if enabled) is printed that describes the results of the job.
- F. Allow approximately one minute for the process to complete a one-page job. It will take longer if you have scanned multiple pages. Then check to make sure that the scanned file has been stored in the repository on the file server.
- G. The Document Centre creates a separate file for each page it scans. (Unless the Enable Multi-Page TIFF option is selected, which will create a single TIFF file for a multi-page document, instead of one TIFF file for each page.) Pages are numbered sequentially. Files are stored on the file server, and the directory path is specified within the job template.

NOTE

If the scanning operation is not successful, check the Confirmation Sheet for a message or other information that may be helpful in identifying the cause of the problem.

- H. The scanned file is transferred to a folder in the scanner account on the file server. The *.XSM* extension on the folder represents a Xerox document storage format that is designed to simplify integration with third-party software applications.
- I. At your workstation, view or list the directory path for the scanner account on the file server. The scanning operation created a folder named *DOC.XSM*.
- J. Open the *DOC.XSM* folder. You should see several files in this folder:
 - 00000001.TIF ...00000002.TIF** for example, are the individual TIFF images of the pages that were scanned. There can be several TIFF files if the document has more than one page, or if **Append** was selected for the *Filing Policy* and more than one document has been scanned. Each page of the document is represented by a different file. (Unless the Enable Multi-Page TIFF option is selected, which will create a single TIFF file for a multi-page document, instead of one TIFF file for each page.)
 - NETSCAN.DAT** is an ASCII file which contains the

names of the TIFF files scanned with the last scanning operation. This file is updated after every successful storage of a .TIF file.

NEXTNAME.DAT is an ASCII file which contains the name of the next available .TIF file. This name is controlled and incremented based on the Filing Policy specified in the job template.

NETSCAN.XST contains the template information for the last file that was scanned. It is also used as a job log for status and a source for the post-processing of information.

XSMDESC.DAT is an ASCII file containing the document name (0-50 characters).

- K. At this point, the TIFF file can be imported into any software application that can accept TIFF files.
- L. Scanning is now ready to operate. Subsequent scanning operations can be modified by changing the selections in the Default Template using the Document Centre Touch Screen.

The installation process is now complete.

Hints and Tips

1. Prior to performing the initial scan job, verify the following from a workstation on the network by logging into the scan account and copying a file into the scan repository:
 - The Document Centre user account and password are correct.
 - The correct rights to the document repository have been assigned to the Document Centre.

Also, make sure that the Confirmation Sheet option is enabled. This provides details of each scan job, including status, filing location, Filing Policy and scan settings. Enabling the Confirmation Sheet is part of the set up procedure detailed in the *Set Up Scanning - NetWare* and *Set Up Scanning - FTP (File Transfer Protocol)* chapters of this guide.

2. You can confirm that a scan job was successfully completed by verifying that the number of pages scanned is the same as the

number of files stored in the document repository for that job. (Unless the Enable Multi-Page TIFF option is selected, which will create a single TIFF file for a multi-page document, instead of one TIFF file for each page).

3. The default directory created for each scan job is DOC.XSM.

Filing Policy

- An **advantage** of the *Overwrite* policy is that minimal disk space is required since files are deleted and recreated for each scan job. This makes it ideal for users with their own file space allocation.
- A **disadvantage** of the *Overwrite* policy is that with a shared document repository, users will overwrite other users' files, possibly before the file is retrieved by the user.
- An **advantage** of the *Append* policy is that no data is lost because users share a document repository.
- A **disadvantage** of the *Append* policy is that disk space may quickly be consumed if not managed properly. This is especially true when each user has his or her own file space.
- An **advantage** of the *New Exact* policy is that it checks to see if any files already exist in the document repository. If there are no files in the repository, the newly scanned files are sent to it.
- A **disadvantage** of the *New Exact* policy is that if there are files stored in the repository, the scan job is aborted.
- An **advantage** of the *New Auto Generate* policy is that it creates a new directory structure, based on the time and date of creation, into which the images are filed.
- A disadvantage of the *New Auto Generate* policy is that while this may seem like the safest policy choice, it also requires more disk space than the *Overwrite* policy.

Optical Character Recognition (OCR)

- If you are using the OCR capabilities of Visioneer PaperPort and TextBridge, it is recommended that you use the *Text* image quality selection and the highest resolution possible. This will ensure optimum OCR capabilities.

Scan Templates

- Use Xerox CentreWare Internet Services to create additional scan templates, so users do not need to manually modify the default scan template for each scan job.

Sharing One Document Repository Among Multiple Document Centres

- More than one Document Centre may use a document repository. Simply configure each Document Centre in a similar manner and create additional scan templates on each Document Centre as needed.

Scan Troubleshooting

You are here because a problem has been identified with the network scanning functions of the Document Centre.

Resolve any copier problems first. Perform the corrective action that is recommended by the **Document Centre User Guide**. Do not attempt to resolve a network scanning problem if the copier functions are not operating correctly.

A. The image quality of the scanned image is not acceptable.

Be sure to select the appropriate image quality setting in the template you are using to scan the image. Use the Image Quality *Text* setting for text documents and the *Photo* setting for grayscale images.

Also, try selecting a scanner resolution of 1.2 to 2.0 times the screen frequency of the device that the file will be displayed or printed on.

B. The optical character recognition (“OCR”) application you are using with the scanned image does not recognise text accurately.

Make sure that you have selected the Image Quality *Text* setting when scanning the document(s).

C. The size of the scanned image file is too large.

Select a scanner resolution of 1.2 to 2.0 times the screen frequency of the device that the file will be displayed or printed on.

Error Messages

Problem	Corrective Action
File delete, replace failed	<ul style="list-style-type: none">• During an Overwrite operation (a Filing Policy option), an attempt to remove files from the remote directory failed. This can be caused by insufficient access rights or by file attributes that are read-only.
Filing directory already exists	<ul style="list-style-type: none">• During a scanning operation, this error can occur when the New Exact Filing Policy is used (set through Internet Services) and the (folder name).XSM directory already exists on the specified path. This is in accordance with the New Exact option.
File transfer failed	<ul style="list-style-type: none">• During a scanning operation, the network or destination server happens to go down when the file transfer is occurring.• Another possibility is that the destination disk is full.
Login failure. Check user, password, and/or setups	<p>A scanning operation failed.</p> <p>Verify the following from a workstation on the network by logging into the scan account and copying a file into the scan repository:</p> <ul style="list-style-type: none">• The user name is invalid or incorrect.• The password is invalid or incorrect. <p>Also check the following:</p> <ul style="list-style-type: none">• The server name is invalid.• The NDS Tree name (NetWare 4.x only) is invalid.• The NDS Context name (NetWare 4.x only) is invalid.

Problem	Corrective Action
Protocol not running	<p>A user tried a scanning operation with a destination on the NetWare server.</p> <ul style="list-style-type: none"> • The NetWare protocol is not currently enabled. Enable it.
Remote directory lock failed	<p>The repository that you are attempting to send a job into with a scanning operation is in use by another Document Centre.</p> <p>Check the following:</p> <ul style="list-style-type: none"> • The specified volume name is invalid. • The specified filing destination (path) is invalid. • The destination disk is full, preventing the creation of the remote directory.

21. E-mail

Overview

With the optional E-mail and Network Scanning kit installed on the Xerox Document Centre 490/480/470/460 ST users can:

- Scan an original document
- Convert the scanned document to an electronic format
- Send that information to one or more E-mail address destinations
- Use the company address book (LDAP)
- Use a public address book (CSV file)

Before You Start

This E-mail chapter assumes you have a general knowledge of your network and the operation of your Web Browser software.

List of items needed before you can setup the Scan to E-mail:

- Document Centre printer is functional on your Network
- Document Centre printer has TCP/IP enabled
- Document Centre printer has HTTP enabled
- Access to a functional SMTP Mail Server
- IP address of SMTP Mail Server
- E-mail and Network Scanning installed
- E-mail domain available (e.g. @mail.company.com)
- Workstation(s) connected to network which has the TCP/IP enabled
- DNS enabled

Internet Messaging is used to setup and maintain the E-mail features of the Document Centre 490/480/470/460 ST.

There are four configuration areas required for Internet Messaging:

- General - Set up access to SMTP Mail Server
- E-mail settings - Configure the default E-mail message and image settings
- LDAP Directory (Lightweight Directory Access Protocol) - Specifies the location and configuration settings of the Internal Address Book that resides on the network
- Public Address Book - Identify the location of a public address book / CSV (Comma Separated Values) file to be used for E-mail. The following two pages are available:
 - Import Public Address Book - To upload a .CSV file containing the E-mail addresses to the machine
 - Map Address Book - after the files is uploaded, this page allows the user to map specific fields in the CSV file to Display (e.g. Name, E-mail Address).

Note: Internet Services (HTTP/IPP) must be enabled, if it is not follow these procedures.

1. Go to the Document Centre control panel.
2. Enter the **Tools** pathway.
 - a) Press the **Access** (**A** or ) button.
 - b) On the keypad enter **1111** or the current password. Press the **Enter** button when finished. The Touch Screen will be used for the remainder of the data entry, unless instructed otherwise.
 - c) Press the **Go to Tools** button.
3. Enter Network Setup.
 - a) Wait for the screen to refresh and press the **Connectivity and Network Setup** button.
 - b) Wait for the screen to refresh and press the **Network Setup** button.
4. Enable HTTP/IP.
 - a) Press the **TCP/IP Options** button.
 - b) Press the **HTTP/IPP** button.
 - c) Press the **Enable** button.
 - d) Press the **Save** button.
 - e) Press the **Close** button - 3 times.
5. Is E-mail enabled?
 - a) If yes, then Press the **Exit Tools** button.
 - b) If no, continue to next page.

Enable E-mail

NOTE

If **Tools** is already up at the Document Center Touch Screen (from previous page) skip Step 1 and 2.

1. Access the System Administrator set up screens.
 - a) Press the **Access** (**A** or ) button.
 - b) On the keypad enter **1111** or the current password. Press the **Enter** button when finished. The Touch Screen will be used for the remainder of the data entry, unless instructed otherwise.
 - c) Press the **Go to Tools** button.
2. Enter Connectivity and Network Setup.
 - a) Wait for the screen to refresh and press the **Connectivity and Network Setup** button.
3. Enable E-mail:
 - a) Select **More**.
 - b) Select **Configuration Setup**.
 - c) At the Warning Screen Select **Close**.
 - d) Select **Optional Services**.
 - e) Select **Scan to E-mail**.
 - f) Select **Enable**.
 - g) Select **Save**.
 - h) Select **Exit Tools**.

Configuring SMTP

1. At a client workstation on the network, launch the Internet Browser.
2. In the URL field, enter http:// followed by the IP Address of the Document Centre 490/480/470/460 ST. Then select the **Enter** key, (e.g. http://xxx.xxx.xxx.xxx).
3. At the CentreWare Internet Services Home Page Select the **Properties** link.
4. Select the plus symbol (+) to the left of the **Services** folder in the **Properties** frame.
5. Select the plus symbol to the left of the **Internet Messaging** folder.
6. Select **General**, as shown in figure below.

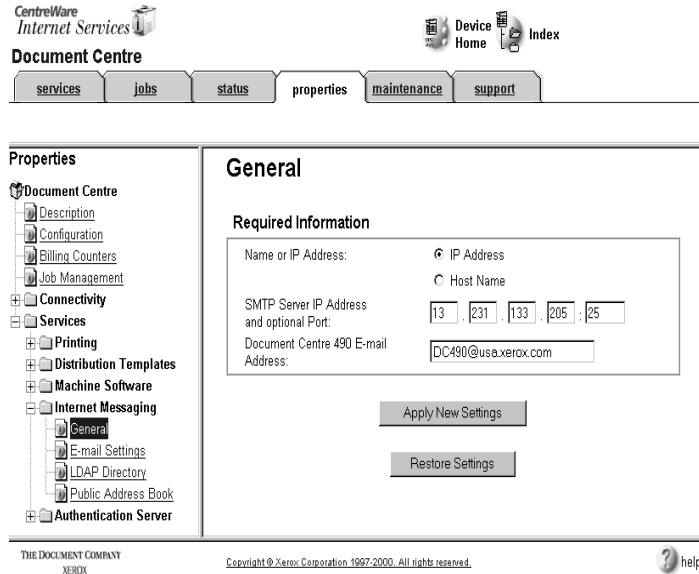

7. Enter the **Host Name** or the **IP Address** of the SMTP Server and a valid **E-mail Domain Name** (x@mail.company.com)

NOTE

The IP Address and Domain Name should be recorded before starting this process.

8. Click the **Apply New Settings** button to implement any changes. If required, Click the **Restore Settings** button to cancel any changes made and return to the previous values.
9. When prompted, enter **admin** (lower case) into the User Name field and **1111** or the current password into the Password field and select **OK**.

NOTE

admin and **1111** are the default Administrator id and password.

Configuring E-mail

The following steps assume you have not left the **Properties** tab, **Services** and **Internet Messaging**.

1. Select **E-mail Settings**.

The screenshot displays the Xerox Document Centre web interface. At the top, there is a navigation bar with 'Document Centre' and tabs for 'services', 'jobs', 'status', 'properties', 'maintenance', and 'support'. The 'properties' tab is active. On the left, a tree view shows the hierarchy: Document Centre > Internet Messaging > E-mail Settings. The main content area is titled 'E-mail Settings' and is divided into two sections: 'Image Attachment' and 'Message Content'. In the 'Image Attachment' section, 'Default Scan Resolution' is set to '300 x 300 dpi Black and White' and 'Default Attachment Type' is set to 'Adobe Acrobat (PDF)'. The 'Message Content' section includes 'Default Subject' (Scan from a Xerox Document Centre), 'Default Message Body' (The attached document was scanned and sent to you using a Xerox Document Centre 470.), 'User' information (User Name: <Name>, E-mail Address: <E-mail Address>), a checkbox for 'Document Centre System' (unchecked) with associated device details, 'Attachment' information (Number of Images: <n>, Attachment File Type: <File Type>), and a 'Default Signature' text area containing 'For more information on Xerox products a...'. At the bottom of the settings area are 'Apply New Settings' and 'Restore Settings' buttons. The footer contains copyright information and a help icon.

2. Select the **Default Scan Resolution** and the **Default Attachment Type** that will be used for image Attachments.

3. Enter the Message Content required for the **Default Subject**.
4. Enter the **Default Signature**, Up to 6 lines of 127 characters each can be entered.
5. Click the **Apply New Settings** button to implement any changes. If required, Click the **Restore Settings** button to cancel any changes made and return to the previous values.
6. When prompted, enter **admin** (lower case) into the User Name field and **1111** or the current password into the Password field. Select **OK**.

LDAP Directory Setup (Internal Address Book)

The Document Centre 490/480/470/460 ST allows you to use the Internal Company Address book, much the same as E-mail at your workstation.

NOTE

Accessing LDAP Directory and Public Address Book are optional.

NOTE

Configuration of the LDAP directory settings requires the network to support LDAP services.

The following steps assume you have not left the **Properties** tab, **Services** and **Internet Messaging**.

1. Select **LDAP Directory**.

The screenshot displays the CentreWare Internet Services web interface. At the top, there is a navigation bar with tabs for 'services', 'jobs', 'status', 'properties', 'maintenance', and 'support'. The 'properties' tab is selected. On the left, a tree view shows the 'Properties' section expanded to 'Internet Messaging', with 'LDAP Directory' selected. The main content area is titled 'LDAP Directory' and contains two sections: 'Server Information' and 'Optional Information'. The 'Server Information' section has radio buttons for 'IP Address' (selected) and 'Host Name'. Below are input fields for 'Server IP Address and Port' (13, 252, 20, 42, 389) and 'Alternate Server IP Address and Port' (13, 252, 20, 220, 389). The 'Optional Information' section includes fields for 'Search Directory Root', 'Login Name', 'Password', and 'Retype password'. It also has a 'Maximum Number of Search Results' field set to 13 (range 5-100) and a 'Search Timeout' section with radio buttons for 'Wait LDAP Server Limit' and 'Wait 30 seconds (5-100)' (selected). At the bottom of the configuration area are 'Apply New Settings' and 'Restore Settings' buttons. The footer contains 'THE DOCUMENT COMPANY XEROX', 'Copyright © Xerox Corporation 1997-2001. All rights reserved.', and a 'Help' icon.

2. Enter the **Server IP Address** or **Host Name** and **optional Port**.
3. Enter any **Optional Information** required.
 - a) Search Directory Root.
 - b) The LDAP server Login Name and Password if required.
 - c) Maximum Number of Search Results.
 - d) Search Timeout.
4. Click the **Apply New Settings** button to implement any changes. If required, Click the **Restore Settings** button to cancel any changes made and return to the previous values.
5. When prompted, enter **admin** (lower case) into the User Name field and **1111** or the current password into the Password field and select **OK**.

NOTE

The Document Centre will display search results for the Internal Address Book as defined by the LDAP configuration. For example, an LDAP server can return a search enquiry "And" as "Andrew Smith" when the result "Andrews, James" may have been expected. The <lastname, firstname> or, <firstname, lastname> display behaviour is controlled by the LDAP server and not the Document Centre.

Network Authentication / Internal Address Book (LDAP) Configured

If a user has successfully logged into a device with Authentication enabled, the Document Centre 490/480/470/460 ST will attempt to automatically match the user's login name to their E-mail address. The user's E-mail address will then be used to populate the "From" E-mail address field. This enables recipients of E-mail jobs to identify the originator of the E-mail job.

Important Information about E-mail Access.

NOTE

When using Authentication, on Windows, Novell, or Kerberos Networks, the User login id is validated. In addition if LDAP is enabled a search is done for LDAP attribute UID.

If a match is found the “From” address will be filled out with the proper and complete E-mail address or “friendly name”. At this point the “From” field will not be an editable field.

If a match can not be found the “From” field will be completed with the users login id @domain.name. At this point the “From” field will be editable.

When using Guest access the “From” field is always editable.

Public Address Book

The Document Centre 490/480/470/460 ST will accept a Public Address Book file that contains a list of user names and their E-mail addresses. This file must be CSV (Comma Separated Values) format for the device to be able to read the file contents.

NOTE

Accessing LDAP Directory and Public Address Book are optional.

NOTE

The majority of word processing packages will allow you to create a CSV file. A selection of E-mail applications will also allow you to export a list of users in the CSV file format.

The completed file is imported to the device through CentreWare Internet Services. The file must have the .CSV file extension.

A valid CSV file, format includes <name>, <SMTP E-mail address>. For example the following are both valid format CSV file entries:

Smith, smith@company.com

"Smith, John"john.smith@company.com

The order in which entries are displayed in the Public Address Book at the Document Centre will depend on how the entries are sorted in the CSV file.



NOTE

It is recommended that you keep a copy of the .CSV file that was to imported.

The following steps assume you have not left the **Properties** tab, **Services** and **Internet Messaging**.

1. Select **Public Address Book**.

CentreWare
Internet Services 

Device Home  Index 

Document Centre

services | jobs | status | properties | maintenance | support

Properties

Document Centre

- Description
- Configuration
- Billing Counters
- Job Management
- Connectivity
- Services
 - Printing
 - Distribution Templates
 - Machine Software
 - Internet Messaging
 - General
 - E-mail Settings
 - LDAP Directory
 - Public Address Book**
 - Authentication Server

Public Address Book

Import Public Address Book

Address Book File (*.CSV):

[Map Existing Address Book](#)

THE DOCUMENT COMPANY
XEROX

Copyright © Xerox Corporation 1997-2000. All rights reserved.

 help

-
2. Browse to the location where you will find the **Address Book File (*.CSV)**.
3. Highlight the .CSV file that you require. Click the **Open** button.
4. Click the **Import Now** button.
5. Click the **OK** button to import the Address Book.

NOTE

If an address book is already in existence, you will be warned that the new import will overwrite the existing address book.

-
-
-
-
-
6. Select **Map Existing Address Book**

- Map the address book by choosing the appropriate **Imported Heading** for each label.

Public Address Book

Map Address Book

Label	Imported Heading:	Imported Sample:
Display Name:	Display Name	Reginal T Farnsworth
E-mail Address:	E-mail Addresses	SMTP:RTFarnsworth@st

Clear All Addresses

[Import New Address Book](#)

Apply New Settings

NOTE

For correct address book operation the Display Name field must map to a user name and the E-mail Address field must map to an SMTP-format E-mail address, for example name@domain.com.

- Click the **Apply New Settings** button to implement any changes. If required, Click the **Restore Settings** button to cancel any changes made and return to the previous values.
- When prompted, enter **admin** (lower case) into the User Name field and **1111** or the current password into the Password field and select **OK**.

Authentication

Authentication is used to identify and authorize the walk-up user via their network login name and password.

NOTE

For Setup Procedures for the Authentication Server see chapter 16 Internet Services, in the Section called Authentication Server.

For Authentication to work it must be enabled from the Document Centre 490/480/470/460 ST Control Panel / UI.

E-mail Authentication

For login in authentication you must enable it at the Document Centre 490/480/470/460 ST Control Panel. Complete the following steps:

1. Enter the **Tools** pathway.
 - a) Press the **Access** (**A** or ) button.
 - b) On the keypad enter **1111** or the current password. Press the **Enter** button when finished. The Touch Screen will be used for the remainder of the data entry, unless instructed otherwise.
 - c) Press the **Go to Tools** button.
2. Set up Authentication:
 - a) Select **More**. (up to 2 times).
 - b) Select **Service Access Control**.
 - c) Select **Network Authenticated Access**.
 - d) Select **Guest Access** and **Guest Passcode**.
 - e) Select **Next**.
 - f) Select **Save**.
 - g) Select **Exit Tools**.
3. Print a Configuration Sheet and verify the settings against the information that was entered.

E-mail Troubleshooting

You are here because a problem has been identified with the Scan to E-mail function of the Document Centre.

Resolve any copier problems first. Perform the corrective action that is recommended by the **Document Centre User Guide**. Do not attempt to resolve a Scan to E-mail problem if the copier functions are not operating correctly.

Problem	Corrective Action
E-mail does not arrive at destination address. No E-mail Error report printed by the device.	<ul style="list-style-type: none">• Check the SMTP address entry to ensure job is being sent to the correct recipient and that the address is spelled correctly.
Device prints an E-mail Error report after an attempt is made to send an E-mail job.	<ul style="list-style-type: none">• Check that the E-mail server settings configured on the device are correct.• Check that the mail server is configured to accept SMTP mail.
Cannot change E-mail "From" address entry.	<ul style="list-style-type: none">• If the user accesses the device using a password with the <i>Guest Authentication</i> feature, then the <i>From</i> address may be changed.
"Reply To" E-mail address receives a mailnote from the SMTP server stating that the mail message was undeliverable due to the attachment or file being too large.	<ul style="list-style-type: none">• Resend the job using a lower scan resolution.• Split the originals into smaller jobs.
Cannot find required entry in the Public Address Book.	<ul style="list-style-type: none">• Try typing the first letter of the entry and then manually scroll the list for the required name.• Check that the address book entries are in the correct order.

Problem	Corrective Action
Public Address Book does not display an address format of name@domain.com for a selected name entry.	<ul style="list-style-type: none"> • Check that the .CSV file contains a name value and an address value separate by a comma, for example the format "Smith, John" - john.smith@company.com. • Check that the mapping of the address book is correct as defined in the Import CSV file screen in the device Web UI.
Cannot find required entry in the Internal Address Book available via LDAP.	<ul style="list-style-type: none"> • Recheck the spelling of the name required. • Try searching on only the first letter of the name. Normally an LDAP environment will search on a <i>Lastname / Firstname</i> order but this may differ depending on the environment.
Attempting an Internal Address Book LDAP search results in a "Too many entries found" error.	<ul style="list-style-type: none"> • Try entering more letters for the name being searched.
Attempting an Internal Address Book LDAP search results in a "Search Tree Invalid" error.	<ul style="list-style-type: none"> • Check the syntax of the LDAP Directory entry. It should be in the format <i>ou=name, o=name</i> but this will vary depending on the LDAP server type and configuration.
Attempting an Internal Address Book LDAP search results in a "No matches found" error.	<ul style="list-style-type: none"> • Check the spelling of the name that you are searching for.

22. Port 9100 Printing

Introduction

Your Document Centre supports printing from a variety of operating systems that support TCP/IP and now supports Port 9100 (RAW) printing, including Linux and Windows 2000.

NOTE

Your Document Centre now has DHCP, LPR, and NetBIOS over the IP protocol enabled by default. If your DHCP server will provide host name, IP address, Gateway address, and Subnet Mask, the Document Centre TCP/IP information will be configured on initial boot.

Your Document Centre has DHCP enabled by default. If your DHCP server is configured with the TCP/IP information for the Document Centre, you should Skip Steps 5 and 6 in this procedure and go to Step 7 to enable Port 9100 printing. If you wish to configure your TCP/IP information statically, complete ALL Steps on the following pages.

Before You Start

To enable 100BaseT or a Token Ring interface, refer to Chapter 2 **How to Connect to Ethernet or Token Ring Networks** to configure the Speed and Source Routing settings for your environment. Then return here and perform this procedure.

For Dynamic TCP/IP Addressing, use the DHCP, BOOTP, or RARP Instructions found in this document in the section entitled **Dynamic/Static TCP/IP Addresses and WINS** to connect it to the appropriate server then return here to complete the setup.

Record the following information assigned to your Document Centre:

IP Address _____

Subnet Mask _____

Default Gateway _____

Go to the Document Center and...

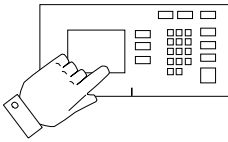

1. Connect your Document Centre to the network with the appropriate cabling.
2. Enter the **Tools** pathway.
 - a) Press the **Access** (**A** or ) button.
 - b) On the keypad enter **1111** or the current password. Press the **Enter** button when finished. The Touch Screen will be used for the remainder of the data entry, unless instructed otherwise.
 - c) Press the **Go to Tools** button.
3. Enter the Network Setup menus.
 - a) Wait for the screen to refresh and press the **Connectivity and Network Setup** button.
 - b) Wait for the screen to refresh and press the **Network Setup** button.
 - c) Press the **TCP/IP Options** button.

4. Enable the network interface and protocol.
 - a) Press the **TCP/IP Settings** button.
 - b) Press the **Protocol and Media** button.
 - c) Press the **Enable** button. If Physical Media buttons appear, select either **Ethernet** or **Token Ring**. Press **Save**.
5. Set the Host Name.
 - a) Press the **Name/Address** button.
 - b) One at a time press the soft buttons on the Touch Screen for each octet of the IP address and enter the numbers using the keypad.
 - c) Press the **Host Name** button.
 - d) When the soft keypad appears, type the host name EXACTLY as you want it to appear with correct case. When finished press the **Save** button twice to record the changes and exit to the **TCP/IP Settings** Screen.

6. Set the Subnet Mask and Gateway.
 - a) Press the **Subnet and Gateway** button.
 - b) Press the soft buttons on the Touch Screen one at a time for each octet of the Subnet Mask and enter the numbers using the keypad.
 - c) Repeat this process for the IP Gateway address. When finished press **Save** to record the changes and exit to the **TCP/IP Settings** screen.
 - d) Press **Close**.
 - e) If you need to lp or lpr print press the **TCP/IP - Line Printer** button, press **Enable** then press **Save**.

NOTE

The Broadcast Address will be calculated automatically.

7. Enable **Port 9100** printing .
 - a) Press the **RAW TCP/IP Printing** button.
 - b) Press **Enable**.
 - c) Press **Save**.
8. Enable HTTP/IPP protocol.
 - a) Press the **HTTP/IPP** button.
 - b) Press **Enable**.
 - c) Press **Save**.
9. Exit the Tools Menu
 - a) Press the **Exit Tools** button.

Go to a workstation and...

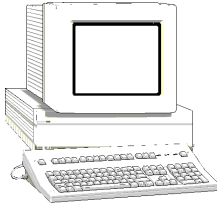

1. Create a test job and send it to the printer with a workstation utility, or through a queue on your operating system that supports Port 9100 printing.
2. Check your test job for quality and use the problem solving section of the **Document Centre Reference Guide** for resolving print defects.
3. If your print job does not print, refer to the troubleshooting section in this document entitled **TCP/IP Troubleshooting** to correct the problem.
4. Repeat this **Go to a workstation and...** procedure at each workstation that will print to this printer, or at other servers where the queue was created.

Glossary

10BASE-T	An implementation of the Ethernet IEEE standard on 24 gauge unshielded twisted-pair wiring, a baseband medium, at 10 megabits per second.
802.3	Defined by the IEEE, these standards govern the use of the CSMA/CD (Carrier Sense Multiple Access/Collision Detection) network access method used by Ethernet networks.
802.5	Defined by the IEEE, these standards govern the use of the Token Ring network access method.
ALAP (AppleTalk Link Access Protocol)	In an AppleTalk network, this link access- (or data link-layer) protocol governs packet transmission on LocalTalk.
ANSI (American National Standards Institute)	This is the principal group in the U.S. for determining standards. ANSI represents the U.S. in the ISO.
AppleShare	A network system implementing the AppleTalk protocol.

AppleTalk	Protocol suite defined by Apple Computer for connecting computers and peripherals using shielded twisted-pair wiring and transfer rates of about 230.4 kilobytes per second. The network- and transport-level protocols include Datagram Delivery Protocol (DDP), AppleTalk Transaction Protocol (ATP), AppleTalk Session Protocol (ASP), and the Name Binding Protocol (NBP).
ARP (Address Resolution Protocol)	TCP/IP protocol for determining a DLC (Data-Link Control) address from an IP (Internet Protocol) address.
ASCII (American Standard Code for Information Interchange)	A seven-bit binary code standardized by ANSI for use by personal computers and some mainframes to represent alphanumeric and graphical characters. An additional bit is included to form an eight-bit character byte.
AUI (Attachment Unit Interface)	Connector used with thick Ethernet that often includes a drop cable.
Bindery	NetWare database of user names, passwords, groups, and accounting information.
BNC	A standardized connector used with Thinnet and coaxial cable.
Bus Topology	A network topology in which nodes are connected to a single cable with terminators at each end.
Client	A network node that requests network services from a server.
Coaxial cable	Data transmission medium with a single-wire conductor insulated EMI/RFI (Electromagnetic Interference/Radio Frequency Interference).
CPU (Central Processing Unit)	A personal computer's primary microprocessor chip.
CSMA/CA (Carrier Sense Multiple Access With Collision Avoidance)	Network access method using contention similar to CSMA/CD used by LocalTalk networks. Unlike CSMA/CD, in this method the sending node requests permission to send from the intended receiving node. If the receiving node responds with a clear to send signal, transmission begins.

CSMA/CD (Carrier Sense Multiple Access/Collision Detection)	Network access method in which nodes contend for the right to send data. If two or more nodes attempt to transmit at the same time, they abort their transmission until a random time period of microseconds has transpired and then attempt to re-send.
DB-9	A standardized connector with 9 pins for Token Ring and serial connections.
DNS (Domain Name Service)	A TCP/IP protocol for discovering and maintaining network resource information distributed among different servers.
DOS (Disk Operating System)	The operating system developed by Microsoft and often ported by computer manufacturers such as IBM to run specifically on their computers.
EMI/RFI (Electromagnetic Interface/Radio Frequency)	A form of “noise” on data transmission mediums that can reduce data integrity and increase transmission errors.
Ethernet	A 10 megabits per second baseband, CSMA/CD network originally designed by Xerox Corporation.
EtherTalk	AppleTalk protocol governing Ethernet transmissions. Also the Apple Computer Ethernet adapter and drivers. The first implementation, Phase 1, was replaced by Phase 2 in 1989.
FTP (File Transfer Protocol)	A TCP/IP application protocol governing file transfer.
GUI (Graphical User Interface)	Icon oriented style of screen display designed by Xerox and the PARC project.
Half Duplex	Method of communication where each character sent is echoed back to its origin.
IEEE (Institute of Electrical and Electronics Engineers)	A professional organization within the ISO that assists with the creation of networking standards.
Internet	Connected networks including those of the National Science Foundation the Advanced Projects Research Agency.

Internetwork	A collection of two or more connected networks that may be dissimilar.
IP (Internet Protocol)	TCP/IP protocol governing packet forwarding.
IPX (Internetwork Packet exchange)	Novell NetWare protocol similar to IP (Internet Protocol).
ISO (International Standards Organization)	A committee of industry leaders who develop telecommunication and application standards.
LAN (Local Area Network)	A system of software and hardware connected by a common data transmission medium and limited to a geographical area less than about 10 kilometers.
LLC (Logical link control)	A layer 2 protocol governing transmission, also known the IEEE 802.2 standard.
LocalTalk	A 230 kilobits per second baseband network using the CSMA/CA access method.
MAC (Medium Access Control)	A layer 2 protocol governing access to transmission media.
MAU (Multi-station Access Unit)	A concentrator or transceiver for attracting nodes to a transmission medium.
MIB (Management Information Base)	A database of network management information used by CMIP (Common Management Information Protocol) and SNMP (Simple Network Management Protocol).
NetWare	Novell's network operating system using IPX (Internetwork Packet Exchange) and SPX (Sequential Packet Exchange) protocols.
NFS (Network File System)	The network operating system based on TCP/IP protocols.
OS/2	A multithreaded, multitasking, single-user operating system.

Packet	A collection of bits comprising data and control information formatted for transmission from one node to another.
Peer to Peer network	A system in which two or more nodes or processes can initiate communications with each other. Usually describes a network in which all nodes have the ability to share resources with other nodes so that a dedicated server can be implemented but is not required.
protocol stack	A representation of the hierarchical nature of a protocol suite.
protocol suite	A hierarchical set of related protocols.
RAM (Random Access Memory)	Memory in which data is temporarily stored for processing.
RARP (Reverse Address Resolution Protocol)	A TCP/IP protocol governing the translation of a DLC (Data-Link Control) address to an IP (Internet Protocol) address.
Repeater	A device that regenerates and often amplifies signals to extend transmission distance. It is independent of protocol and media.
RG-58	Coaxial cable with 50-ohm impedance used by Thinnet.
RJ-45	Eight-wire modular connectors for Ethernet, Token Ring, StarLAN networks, and some phone lines.
SNMP (Simple Network Management Protocol)	TCP/IP protocol governing network monitoring.
SPX (Sequential Packet Exchange)	The implementation of SPP (Sequential Packet Protocol) by Novell.
TCP (Transmission Control Protocol)	TCP/IP protocol governing sequenced data.
TCP/IP (Transmission Control Protocol/Internet Protocol)	A protocol suite developed by ARPA (Advanced Research Projects Agency).

Telnet	TCP/IP protocol governing character-oriented terminal data.
Thicknet	Cabling scheme using twin axial cable.
Thinnet	Cabling scheme using 50 ohm coaxial cable.
Token	The character sequence passed among nodes in sequence to indicate which one has permission to transmit.
Token passing	Network access method that requires nodes to wait for their turn before transmitting data. Turns are indicated by a character sequence that passes from one node to the next.
Token Ring	A 4 megabit per second or 16 megabit per second network using a ring topology and a token passing access method.
Transceiver	An AUI (Attachment Unit Interface) device for receiving and transmitting data that often provides collision detection as well.
twisted pair cable	A wiring scheme with one or more pairs of 18 to 24 gauge copper strands are twisted to improve protection against electromagnetic and radio frequency interference. Cable may be either shielded or unshielded.
type 1 cable	Shielded two-pair cable.
type 3 cable	Unshielded twisted-pair cable.
type 5 cable	Shielded twisted-pair cable.
WAN (Wide Area Network)	A network capable of transmissions over large geographic areas that uses transmission lines provided by a common-carrier.
workstation	A networked computer typically reserved for end-user applications.
Zone	One or more connected AppleTalk networks grouped according to network usage.

Index

A

- Active jobs 16-35
- Administration Logon 16-11
- Alert messages 16-38
- Appletalk 16-49

B

- Banyan VINES 15-1, 16-51

C

- CentreWare Device Admin 4-1
- Configuration 16-42
- Configuring
 - E-Mail 21-8
 - SMTP 21-6
- Connectivity 16-45
- Creating distribution templates 16-21

D

- Default Template 20-7
- Default template
 - Properties 16-90
- Defining IP restrictions 16-72
- Delayed printing 16-16
- Deleting print jobs 16-44
- Description 16-41
- Displaying font list 16-104

- Distribute to Fax 16-30

- Distribute to File 16-29

- Distribution templates 16-17

- Copying 16-33
 - Creating 16-21
 - Deleting 16-32
 - Properties 16-82
 - Updating 16-33

- Document Centre
 - status 16-37

- Document Centre properties 16-40

- Documentation 1-5

- Dynamic Addressing 3-2

E

- E-mail
 - Authentication 21-16
 - Configuring 21-8
 - Enabling 21-5
 - HTTP 21-4
 - SMTP 21-6
 - Troubleshooting 21-17

- Enabling

- Ethernet 16-45
 - Parallel Port 16-47
 - Refresh function 16-7
 - Token Ring 16-48

- Error Messages 20-37
- Ethernet 16-45
- Existing Accounts 20-14
- F
- FAX
 - FTP Installation 19-2
 - IPX/SPX Installation 19-5
 - Troubleshooting 19-8
- Fax settings 16-94, 16-95
- Filing destination 16-26
- Filing destination settings 16-93
- Filing Policy 20-12, 20-34
- Font listing 16-104
- G
- General properties 16-77
- General template settings 16-22
- H
- HTTP settings 16-69
 - Security 16-72
- I
- Immediate printing 16-14
- Installation Considerations 20-34
- Installation Requirements 20-27
- Installing ESS software 16-106
- Internet Services
 - Interface features 16-8
 - Managing jobs 16-34
 - Properties 16-40
 - Services 16-13
 - Status 16-37
 - Using 16-12
- IP restrictions
 - Granting 16-73
- J
- Job
 - Delete permission 16-44
 - Submission Page 16-13
- Jobs 16-35
- L
- Logging in to Multiple File Servers 20-14
- LPR/LPD 16-65
- M
- Macintosh Networks 14-1
- Maintenance 16-104
 - Display a font list 16-104
 - Machine software install 16-106
 - Print a test page 16-108
- Managing jobs 16-34
- Microsoft (NetBEUI) 8-1
- Microsoft (TCP/IP) 9-1
- Microsoft Networking 16-64
- Microsoft Windows NT 4.X Server 11-1
- Multi-Page TIFF 20-13, 20-16, 20-26
- Multiple Logins 20-14
- N
- NETSCAN.DAT 20-22, 20-31
- NETSCAN.XST 20-22, 20-32
- NetWare
 - Set Up Options 20-16
 - Set Up Scanning 20-19
- Netware 16-53
- Network Accounting
 - Setup 18-4
 - Troubleshooting 18-8
- Network connectivity 16-45
- Network protocols
 - Appletalk 16-49
 - Banyan VINES 16-51
 - LPR/LPD 16-65
 - Microsoft Networking 16-64
 - NetWare 16-53
 - Port 9100 Printing 16-67
 - SNMP 16-57
 - TCP/IP 16-55
- NEXTNAME.DAT 20-22, 20-32
- Novell NetWare 3.1x or 4.x/5.x 6-1
- Novell NetWare 4.X and 5.X 5-1

- O
- Optical Character Recognition (OCR) 20-34
- OS/2 (NetBEUI) 13-1
- OS/2 (TCP/IP) 12-1
- Output Image Quality 20-13, 20-26
- Output settings(TIFF) 16-81
- P
- Parallel Port 16-47
- PCL 16-80
- Physical connections 16-45
- Port 9100 Printing 22-1
- PostScript settings 16-79
- Print jobs
 - Deleting 16-36
 - Listing 16-35
- Printing 16-77
 - Documents 16-13
 - Test page 16-108
- Properties
 - Billing counters 16-43
 - Configuration 16-42
 - Connectivity 16-45
 - Default template 16-90
 - Description 16-41
 - HTTP settings 16-69
 - Security 16-72
- Public Repositories 20-11
- R
- RAW TCP/IP Printing 16-67, 22-1
- Refresh function
 - Enabling 16-7
- Repository Filing Policy 20-12
- Repository set up for templates 16-85
- S
- Scan Policy
 - Append to Existing File 20-12
 - Do Not Save 20-12
 - Overwrite Existing File 20-12
 - Rename 20-12
- Scan Settings 16-23
 - Properties 16-92
- Scan to Fax settings
 - Properties 16-94, 16-95
- Scan to File settings 16-93
- Scanning 20-6
 - Overview 20-5
 - Private Repositories 20-12
 - Process 20-8
 - Repositories 20-11
 - Repository Sharing 20-35
 - Set Up Options 20-24
 - Set Up TCP/IP 20-28
 - Templates 20-7, 20-35
- Scanning documents 16-17
- Scanning functionality 16-17
- Services
 - Properties 16-77
- Setting up distribution templates 16-19
- SNMP 16-57
 - Community Names 16-58
- Static Addressing 3-6
- Status
 - Tab 16-37
- Support information 16-110
- T
- TCP/IP 16-55
- Template functions 16-19
- Template management 16-19
- Template pool setup 16-88
- Template settings 16-22
 - General 16-22
 - Scan 16-23
- Templates
 - Filing destination 16-26
 - Scan settings 16-29
- Terminology 20-2
- Testing print capability 16-104
- TIFF 16-81

Token Ring 2-1, 16-48

Tray status 16-39

Troubleshooting

AppleTalk 17-11

Banyan VINES 17-13

E-mail 21-17

Internet Services 16-111

Netware 17-5

Network Accounting 18-8

Network FAX 19-8

OS/2 17-9

Scan 20-36

U

UNIX 7-1

Using Internet Services 16-12

V

Viewing active alert messages 16-38

Viewing general status 16-37

Viewing support information 16-110

Viewing tray status 16-39

W

Windows 2000 LPR and IPP Printing
10-1

WINS 3-10

X

XSMDESC.DAT 20-22