

**XEROX®**

**Version 1.0**  
July 2008

---

# DocuColor 5000AP User Guide



©Copyright 2008 by Xerox Corporation. All Rights Reserved.

Copyright protection claimed includes all forms and matters of copyrighted material and information now allowed by statutory or judicial law or hereinafter granted, including without limitation, material generated from the software programs that are displayed on the screen such as styles, templates, icons, screen displays, looks, etc.

Xerox® and all Xerox product names and product numbers mentioned in this publication are trademarks of XEROX CORPORATION. Other company brands and product names may be trademarks or registered trademarks of the respective companies and are also acknowledged.

This product includes software developed by the Apache Software Foundation (<http://www.apache.org/>).

---

# Table of contents

<b>1. Overview</b>	<b>1-1</b>
Identifying the digital press components . . . . .	1-2
External components . . . . .	1-2
Other external components. . . . .	1-4
Dry Ink/Toner Waste Bottle . . . . .	1-4
Ground Fault Indicator (GFI) circuit breakers . . . . .	1-5
Identifying the internal components . . . . .	1-6
Serial number label . . . . .	1-6
Dry Ink/Toner Cartridges . . . . .	1-7
Transport Module . . . . .	1-7
Paper Transport Drawer . . . . .	1-8
Exit Module . . . . .	1-9
Paper path in the digital press . . . . .	1-10
User Interface (UI) . . . . .	1-10
Application menu area . . . . .	1-12
System menu . . . . .	1-12
Machine Details. . . . .	1-12
Help menu. . . . .	1-13
Job/System Status area . . . . .	1-14
Job Summary . . . . .	1-14
Machine mimic and Message area . . . . .	1-15
Tray status area . . . . .	1-16
Main control buttons . . . . .	1-16
Logon and current User level . . . . .	1-16
Current User Level . . . . .	1-17
Language . . . . .	1-17
Power Saver . . . . .	1-18
Pause . . . . .	1-19
Dry Ink/Toner status area . . . . .	1-19
Operator/Administrator buttons. . . . .	1-20

Billing & Counters . . . . .	1-21
Consumables . . . . .	1-22
Administrator buttons . . . . .	1-23
Relocating the digital press. . . . .	1-23
Customer documentation updates . . . . .	1-24

## **2. Tray Properties** **2-1**

---

Overview . . . . .	2-1
Tray Properties window . . . . .	2-2
Current tray information . . . . .	2-3
Not available for... . . . .	2-3
Auto Tray Switching . . . . .	2-3
Auto Paper Selection . . . . .	2-3
Enable/Disable . . . . .	2-3
Size . . . . .	2-4
Custom Paper Size . . . . .	2-4
Type . . . . .	2-4
Weight . . . . .	2-4
Decurler Profile . . . . .	2-5
Alignment Profile . . . . .	2-6
Display... . . . .	2-7
Help button . . . . .	2-7
Selections made on the Tray Properties window . . . . .	2-7
Basic paper information . . . . .	2-8

## **3. Paper information** **3-1**

---

Recommended Materials List (RML) . . . . .	3-1
Paper handling . . . . .	3-1
Paper guidelines . . . . .	3-3
Curl . . . . .	3-4
Paper specifications . . . . .	3-5
Transparency guidelines . . . . .	3-6
Tabbed inserts . . . . .	3-6
Drilled paper . . . . .	3-7
1-Sided Print Jobs . . . . .	3-7
2-Sided Print Jobs . . . . .	3-7
Letterhead . . . . .	3-8
Custom (nonstandard) size paper . . . . .	3-8
Paper weight conversion tables . . . . .	3-9
Specific weight conversion . . . . .	3-9
Weight conversion ranges . . . . .	3-10

Loading paper . . . . .	3-11
Paper trays air adjustment: . . . . .	3-12
Tray Stock Mismatch. . . . .	3-13
<b>4. Accessories</b>	<b>4-1</b>
Trays 3 and 4 (Second Feeder Module) . . . . .	4-1
Identifying the parts. . . . .	4-1
Paper path . . . . .	4-2
Paper guidelines . . . . .	4-2
Paper Specifications . . . . .	4-3
Loading paper . . . . .	4-4
Paper trays air adjustment . . . . .	4-4
Jam clearance . . . . .	4-4
Physical characteristics. . . . .	4-4
Size . . . . .	4-4
Weight. . . . .	4-4
Floor space requirements . . . . .	4-4
High Capacity Stacker . . . . .	4-5
Identifying the parts. . . . .	4-6
Control panel. . . . .	4-6
Cooling fan . . . . .	4-7
Paper path . . . . .	4-9
Top Tray . . . . .	4-9
Stacker Tray . . . . .	4-9
Bypass . . . . .	4-9
Paper guidelines . . . . .	4-10
Recommended baseline/centerline. . . . .	4-10
Paper specifications . . . . .	4-11
Unloading the Stacker Tray. . . . .	4-12
Selecting Features . . . . .	4-13
How to Enable Automatic Output Switching . . . . .	4-13
Using a DFA Finishing Device . . . . .	4-13
Jam clearance . . . . .	4-13
Clear Bypass area jam . . . . .	4-14
Clear Top Tray and Stacker Tray paper jams . . . . .	4-15
Maintenance . . . . .	4-15
Problem Solving . . . . .	4-16
Loss of Power . . . . .	4-17
Common Stacker/Stapler (CSS) . . . . .	4-18
Identifying CSS Parts . . . . .	4-18
Control Panel . . . . .	4-19
Electrical/environmental requirements . . . . .	4-20

Paper stock specifications . . . . .	4-20
Paper Path . . . . .	4-22
Using the stacker/stapler . . . . .	4-23
Hints and tips . . . . .	4-23
Stapling Hints . . . . .	4-23
Paper specifications for stapling . . . . .	4-24
Staple Positions . . . . .	4-25
Stapling capacity for different paper types and weights . .	4-27
Unloading the stacker/stapler . . . . .	4-27
Jam Clearance . . . . .	4-28
Ordering and Loading Staples . . . . .	4-29
Stacker/stapler Maintenance. . . . .	4-30
Cleaning the stacker/stapler . . . . .	4-30
Problem Solving . . . . .	4-30
Loss of Power . . . . .	4-33

## **5. Problem solving** **5-1**

---

General problems . . . . .	5-1
Jam clearance . . . . .	5-5
Paper tray jams. . . . .	5-6
Upper Transport Area jam . . . . .	5-7
Transport Module jams . . . . .	5-8
Exit Module jams . . . . .	5-9
Right/left door paper path jams. . . . .	5-10
Jam clearance with 2-sided printing . . . . .	5-12
Fault Codes . . . . .	5-13

## **6. Technical Data** **6-1**

---

Digital Press Specifications. . . . .	6-1
Electrical Power . . . . .	6-1
Specifications . . . . .	6-1
Power Consumption . . . . .	6-1
Warm-up Time . . . . .	6-1
First Print Out Time. . . . .	6-1
Reliability. . . . .	6-1
Environmental Requirements . . . . .	6-2

---

Ambient Temperature and Humidity . . . . .	6-2
Altitude . . . . .	6-2
Illumination . . . . .	6-2
Noise Levels . . . . .	6-2
Ozone Emissions . . . . .	6-2
Dust. . . . .	6-3
Capabilities . . . . .	6-3
Tray Capacity . . . . .	6-3
Throughput . . . . .	6-3
Output Tray Capacity . . . . .	6-4
Print Rates . . . . .	6-4
Physical Characteristics . . . . .	6-5
Digital Press Size . . . . .	6-5
Digital Press Weight . . . . .	6-5
Floor Space Requirements . . . . .	6-5
Metric Conversion Chart . . . . .	6-6

## **7. Maintenance** **7-1**

---

Cleaning procedures. . . . .	7-1
Cleaning the digital press . . . . .	7-1
Cleaning the UI screen . . . . .	7-1
Cleaning the Second Transport and Fusing areas . . . . .	7-2
Cleaning the paper path . . . . .	7-6
Replacing Consumable Supplies . . . . .	7-10
Replacing a Dry Ink/Toner Cartridge. . . . .	7-11
Changing the Dry Ink/Toner Waste Bottle. . . . .	7-13
Adding Fuser Oil . . . . .	7-15
Replacing the Fuser Web Assembly. . . . .	7-16
Calling for Service. . . . .	7-22
Consumable Supplies. . . . .	7-23





---

# 1. Overview

The DocuColor 5000AP is a full color/black and white digital press operating at a speed of fifty prints per minute. This chapter includes the following information:

- Identifying the digital press components, their names, locations, and functions
- Identifying the User Interface, its various components, and briefly discussing their functions



**NOTE:** *The UI screens shown in this guide here may or may not reflect the UI screens displayed on your system. The UI screens vary from system to system and from marketplace to marketplace. Therefore, the UI screens in this guide here are a representation of the type of screens that may be seen on your particular system.*



## Identifying the digital press components

### External components

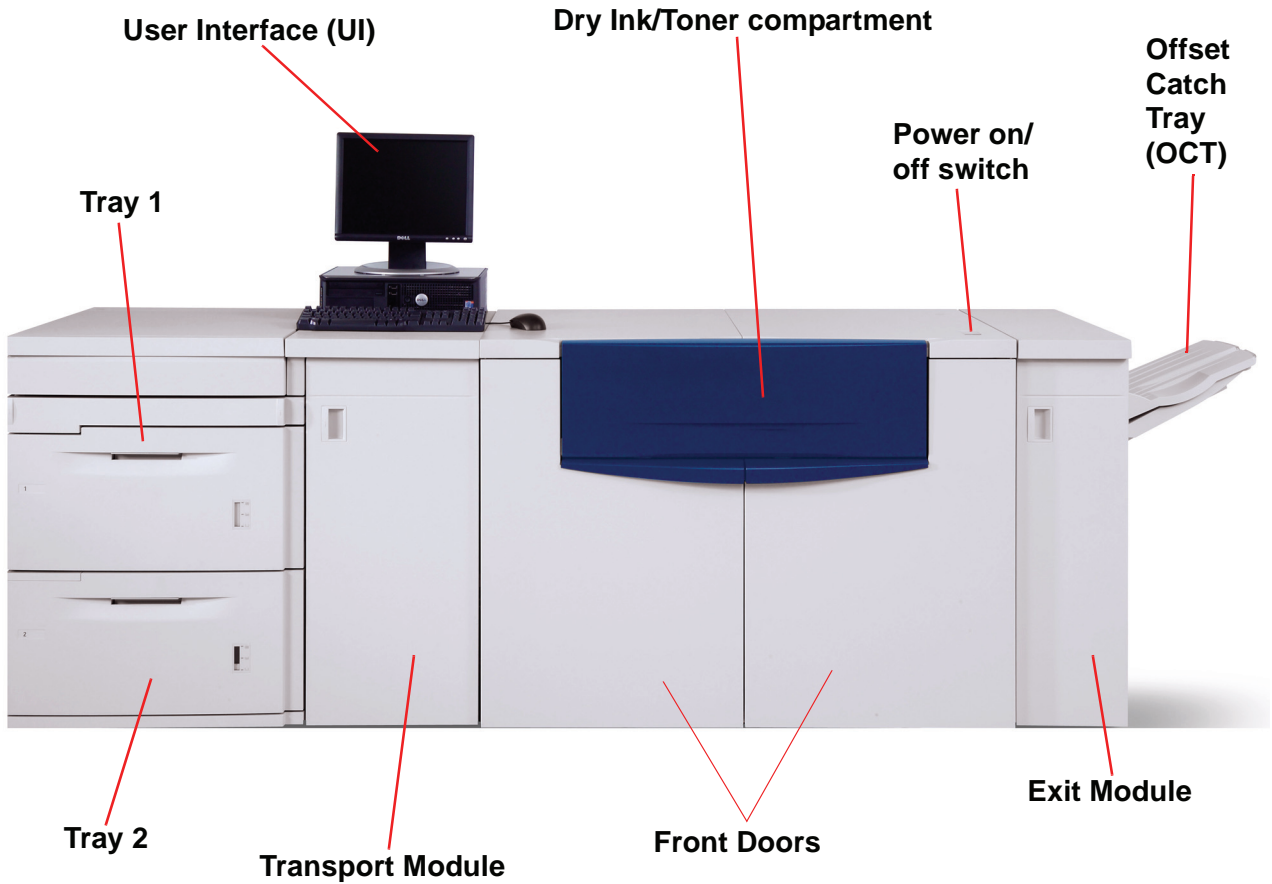
Use the illustration below and the following table to identify the external components that comprise the DocuColor 5000AP system.

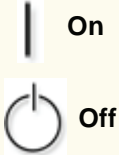

**NOTE:** The illustration above may or may not reflect the PC that is delivered with your machine. This illustration is only a representation of the type of PC that may come with your machine.

Part	Description
<b>User Interface</b>	The User Interface (UI) displays messages that indicate the status of the digital press during idle, run, or fault conditions. For more detailed information, go to page 1-10.
<b>Dry Ink/Toner Compartment</b>	Contains the Dry Ink/Toner cartridges. The cartridge colors from left to right, are black, cyan, magenta, and yellow. Refer to page 7-11 for instructions on changing the cartridges.
<b>Power On/Off switch</b> 	<p>Press the Power Switch to the <b>On</b> position to power on the digital press. A screen message advises of a short wait while the Fuser warms up and the digital press runs a system check.</p> <p>Press the Power Switch to the <b>Off</b> position to power off the digital press. Allow the digital press to remain off for a minimum of twenty seconds before switching the power on again.</p>
<b>Offset Catch Tray (OCT)</b>	<p>Receives completed print job. Sets are offset for easy separation. Maximum capacity is 500 sheets of 24 lb. (90 g/m<sup>2</sup>) paper.</p> <p>Optional finishing devices are discussed in Chapter 4 Accessories, starting on page 4-5.</p>
<b>Exit Module</b>	Contains the decurler and the inverter. The decurler removes any curl from the printed page. The inverter is used when duplexing or face down output is selected. For more information go to page 1-9.
<b>Right/Left Front Doors</b> 	<p>Houses the image transfer system for simplex and duplex printing. Open to clear jams in the paper path in the Printing Module and at the Fuser. Follow the instructions on the UI precisely for clearing a jam in the Fuser.</p> <p><b>WARNING: The Fuser is extremely hot and will cause injury if jam clearing instructions are not followed.</b></p>
<b>Transport Module</b>	The Transport Module carries the paper from the paper trays to the upper paper path of the digital press. It also routes the paper from the lower paper path of the digital press to the upper paper path of the digital press when duplexing. For more information go to page 1-7.
<b>Paper Tray 1</b>	Holds 2000 sheets of 24 lb. (90 g/m <sup>2</sup> ) paper.
<b>Paper Tray 2</b>	Holds 2000 sheets of 24 lb. (90 g/m <sup>2</sup> ) paper.

## Paper trays 1 and 2

---

Paper Trays 1 and 2 are the standard paper trays for the basic configuration of the digital press. Each tray holds 2000 sheets of 24 lb. (90 g/m<sup>2</sup>) paper.

**Duplexing** The digital press duplexes prints from all paper trays up to 220 g/m<sup>2</sup>. The system does not duplex media larger than 12.6 x 18 inch (321.1 x 458.1 mm).

**Optional paper trays** An optional Second Feeder Module (SFM) containing Trays 3 and 4 is available for as an additional paper source. The optional SFM is discussed in more detail in Chapter 4 Accessories, page 4-1.

## Other external components

---

### Dry Ink/Toner Waste Bottle

---

The Dry Ink/Toner Waste Bottle collects the waste dry ink/toner in the printing process. The Dry Ink/Toner Waste Bottle is customer replaceable and located in the rear of the machine.

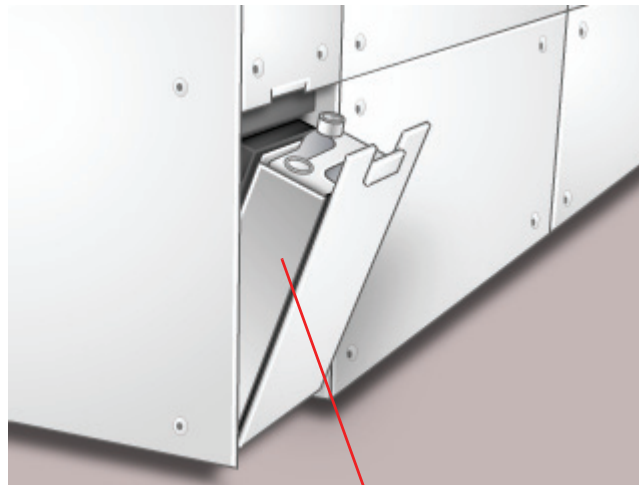

**Dry Ink/Toner  
Waste Bottle**

Refer to Chapter 7 for instructions on changing the Dry Ink/Toner Waste Bottle.

## Ground Fault Indicator (GFI) circuit breakers

The digital press is equipped with two safety circuit breakers called a Ground Fault Indicators (GFI). These devices trip if the power to the digital press is interrupted.

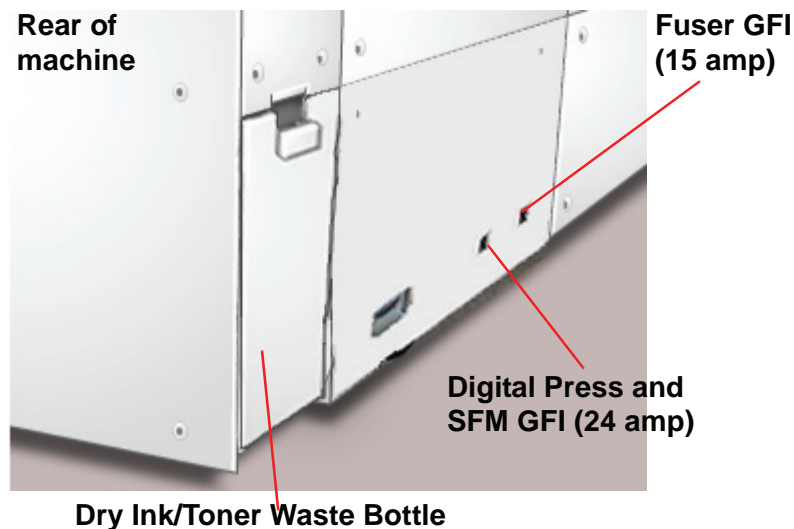

**Fuser GFI** The Fuser receives power through the Fuser GFI.

**Digital Press GFI** The digital press receives power through the Digital Press GFI. If an optional Second Feeder Module is connected to the Digital Press, then it too receives power from this GFI.

**After a power outage occurs:** Power on the digital press as soon as possible after the power is restored, and print a job to ensure that there is no damage to the digital press.

If power to the digital press is interrupted,

- Locate the circuit breakers on the back of the digital press next to the toner waste bottle.
- If either device is tripped, the switch is in the Off position (down). Flip the switch up.



**NOTE:** If the device trips again or if power is not restored by the above procedure, call your Xerox service representative.

## Identifying the internal components

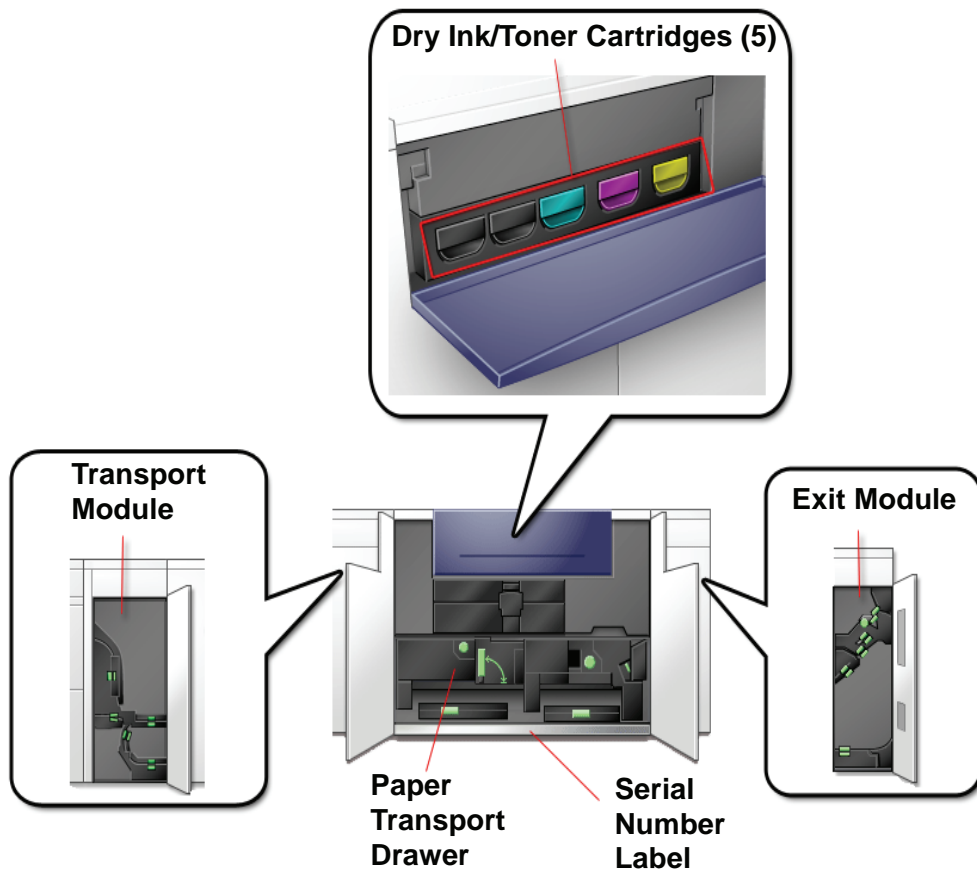

### Serial number label

If the digital press loses power and it is impossible to access the Machine Details tab for the serial number, open the two main front doors. The serial number label is in the center of the bottom frame of the digital press.

## Dry Ink/Toner Cartridges

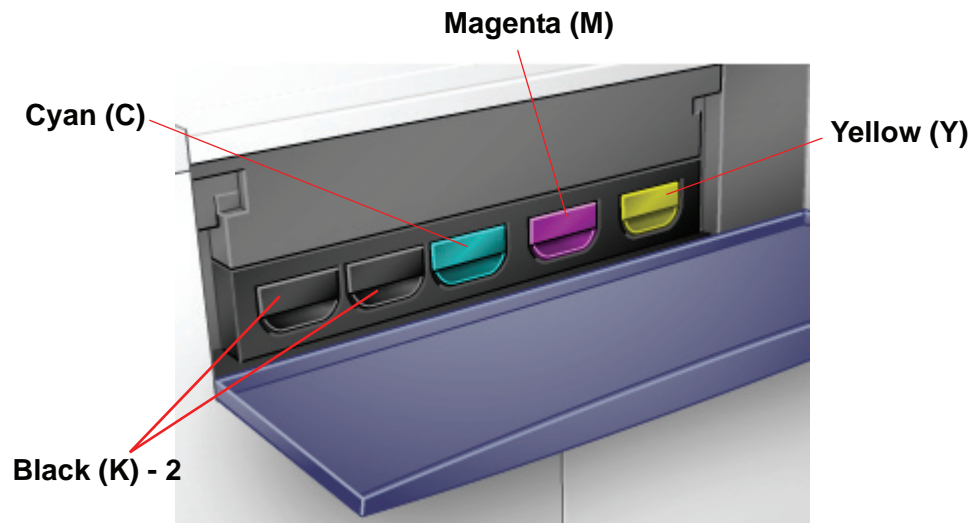

There are five Dry Ink/Toner Cartridges: Two Black (2) and one each for Cyan (C), Magenta (M), and Yellow (Y).

The toner cartridges supply a mix of toner and developer to their respective drum cartridges. There are two Black (K) cartridges because black requires more toner since black is the most heavily used color.

## Transport Module



The Transport Module carries the paper from the paper trays to the upper paper path of the digital press. It also routes the paper from the lower paper path of the digital press to the upper paper path of the digital press when duplexing.

Paper from all trays moves through the Transport Module to the upper paper path in the digital press. The lower paper path carries duplexed (2-sided) sheets through the Transport Module to the digital press upper paper path.

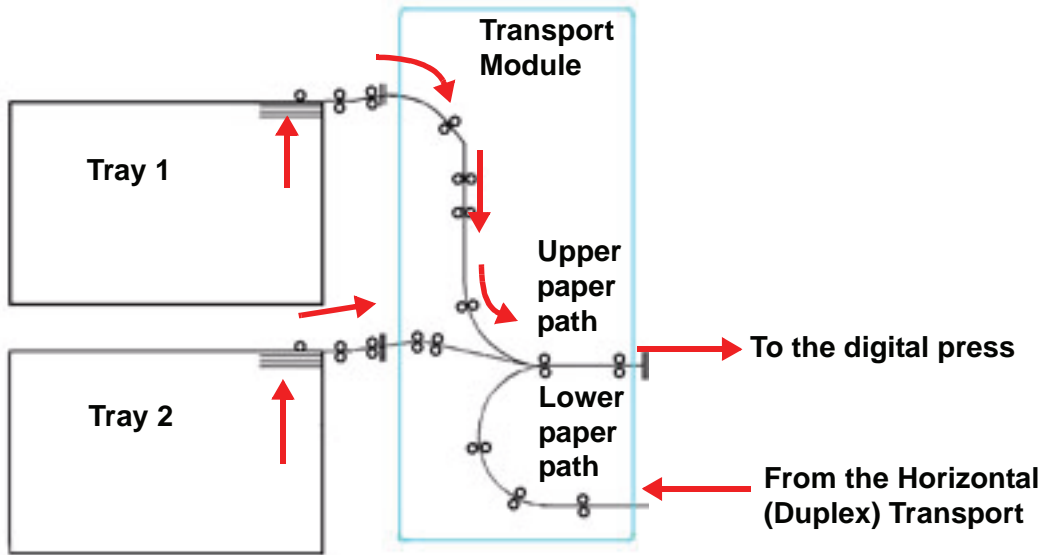

### Paper Transport Drawer

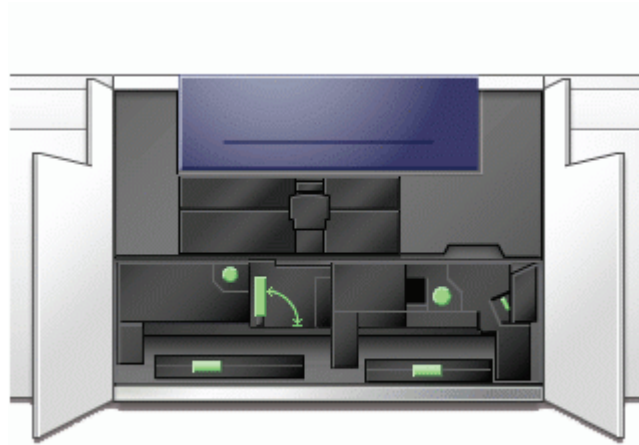

This area is where paper is aligned, the image is applied and fused, and the paper is flipped over if duplexing is required.



## Exit Module

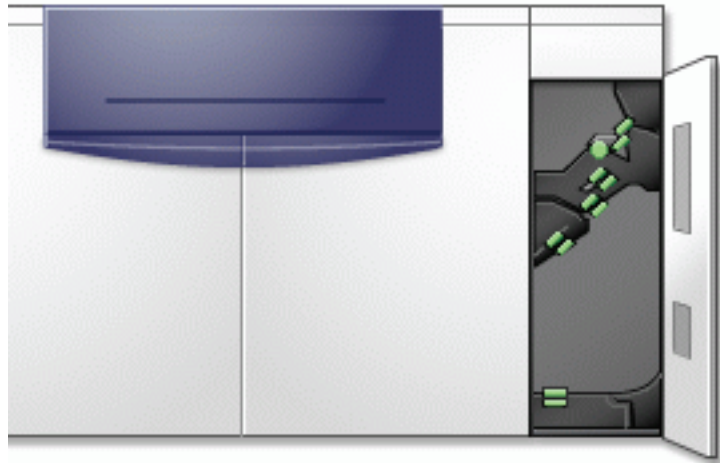

A completed print passes through the Exit Module to the Offset Catch Tray or other finishing device. The Exit Module contains a Decurler that removes paper curl caused by the fusing process. The Exit Module also contains an Inverter which turns the paper over to image side two when duplexing, or when face down output is selected.

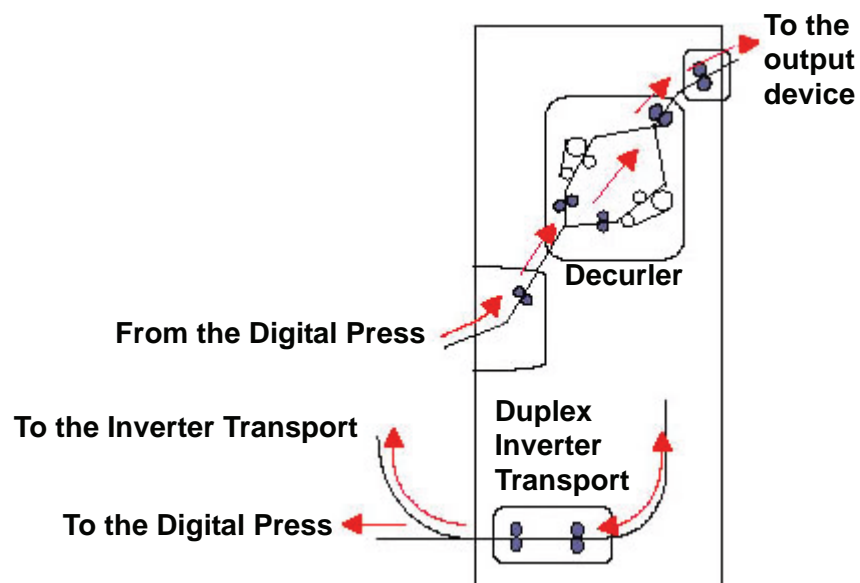

## Paper path in the digital press

The paper path transfers an image to the paper and fuses it for both the simplex and duplex selections. It has two areas, the upper paper path and the lower paper path. The upper path is used for both simplex and duplex. The lower path is used for duplexing only. The Horizontal Transport 1 decurls the paper when printing duplex.

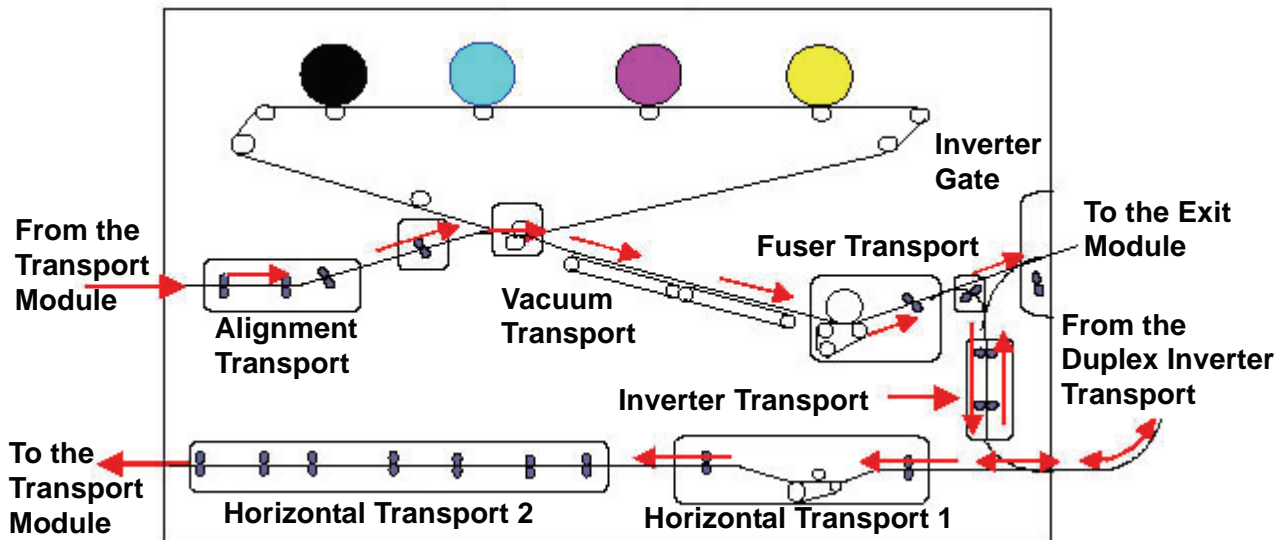

## User Interface (UI)

The User Interface (UI) displays messages that indicate the status of the digital press during idle, run, or fault conditions.



**NOTE:** The illustration above may or may not reflect the PC that is delivered with your machine. This illustration is only a representation of the type of PC that may come with your machine.

The default, main screen shown on the UI is shown in the illustration below.

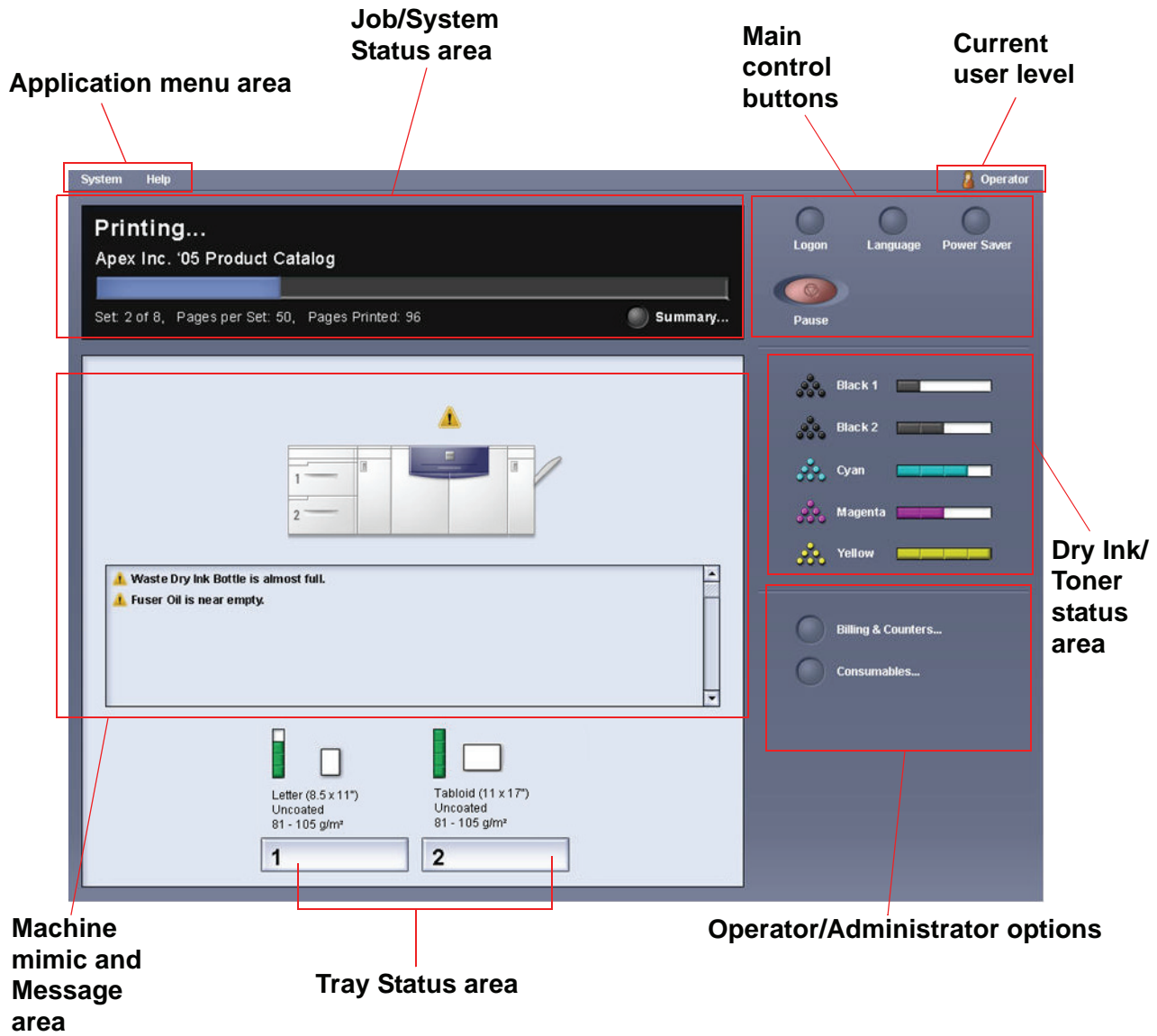

## Application menu area

This area of the main screen is comprised of two pull-down menus: **System** and **Help**.

### System menu

The System pull-down menu allows you to select the following options:

- **Machine Details:** By selecting this option, a Machine Details window opens. Refer to “Machine Details” on page 1-14 for more information on this feature.
- **Shutdown System PC:** This option shuts down the User Interface and the system PC.
- **Restart User Interface:** This option stops and exits the User Interface and then restarts it.
- **Exit User Interface:** This option exits the User Interface but leaves the System PC running.

An additional feature may be selected when the machine is configured for it:

- **Finishing System Module:** This option is available only if an optional finishing device is attached to your system. If an optional finishing device is attached and you are logged in as the Administrator, then this feature is available from the pull-down menu.

### Machine Details

Selecting the **Machine Details** feature from the **System** pull-down menu displays the following window.

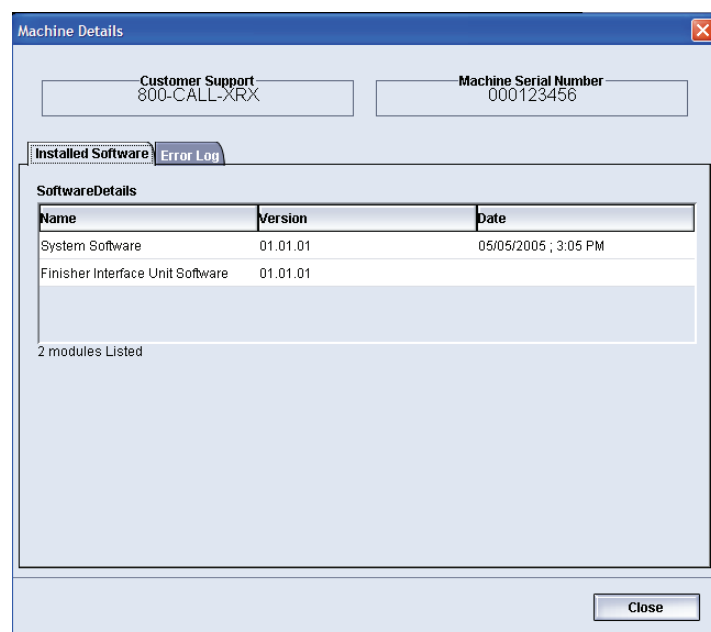

The Machine Details window provides specific information about your machine, such as:

- **Customer Support** telephone number
- **Machine Serial Number**
- **Installed Software:** This tab displays a list of installed software, version level, and date of installation. This tab also displays a list of any installed optional finishing devices.
- **Error Log:** This tab displays a list of all the machine errors, fault ID number, and date the error occurred.

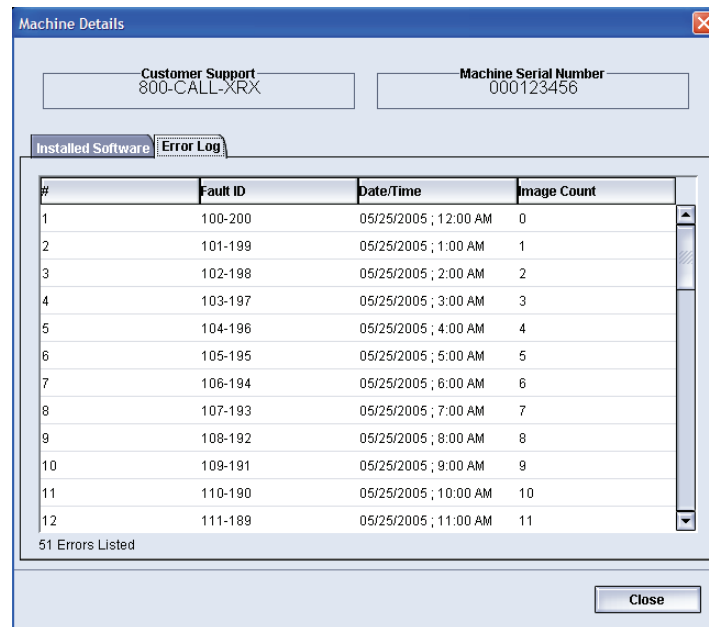

## Help menu

Selecting DocuColor 5000AP from the Help pull-down menu opens a new window displaying the following type of information:

- An overview of the digital press and UI
- Paper tray information, including:
  - Paper specifications
  - Paper guidelines
  - Loading paper
  - Changing paper sizes in the trays
- Information about the various optional accessories
- Problem solving information
- Technical data
- Maintenance information, including:
  - Cleaning procedures
  - Replacing Customer Replaceable Units (CRUs) procedures

- Administrator information:
  - An overview of Administrator features, including:
    - System Settings
    - Custom Paper Profiles
    - Decurler
    - Alignment Profiles
  - Step-by-step procedures for the Administrator features

## Job/System Status area

---

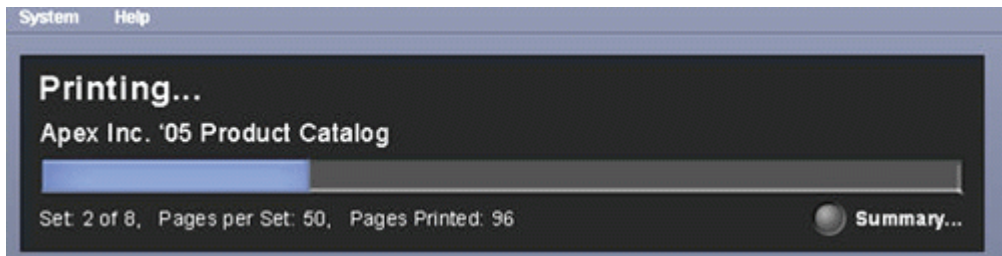

This area of the screen displays the status of the system, such as Ready, Waiting for print, Powering up, Powering down, etc. This area also displays the status of any currently printing job.

## Job Summary

---

Selecting **Summary** button opens the **Current Job Summary** window:

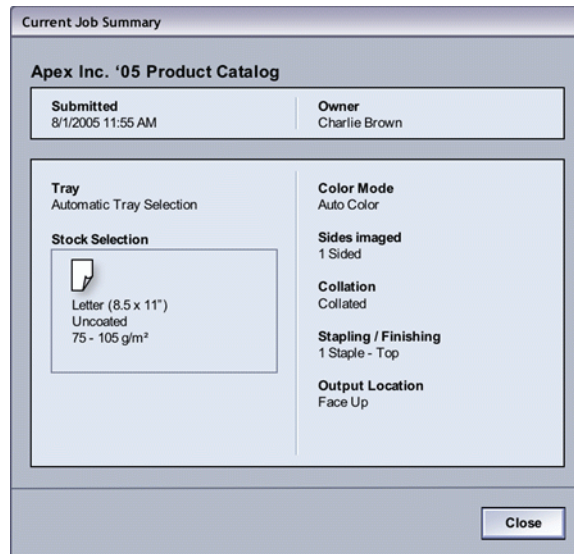

## Machine mimic and Message area

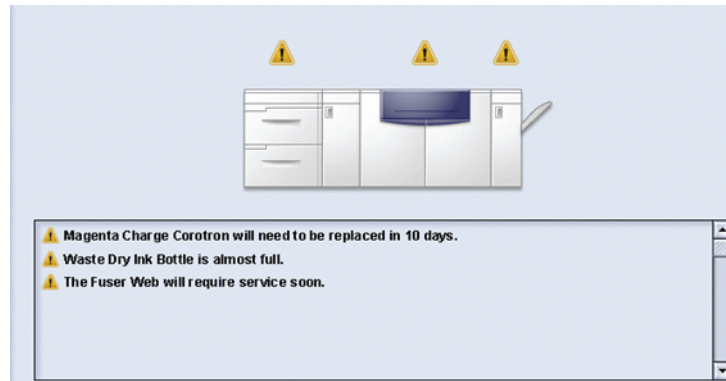

This area displays information about the machine including:

- The status of various machine components, such as the Dry Ink/Toner and Fuser Web,
- Alerts when a Customer Replaceable Unit (CRU) component needs replacement, or
- Warnings and faults



**TIP:** The UI automatically opens a Details window which provides additional information about the alert, warning, or fault. The information on this Details window provides step-by-step instructions and assists you in restoring the machine to normal performance. If this window does not automatically open, you may click on the alert, warning, or fault, thereby opening the window.

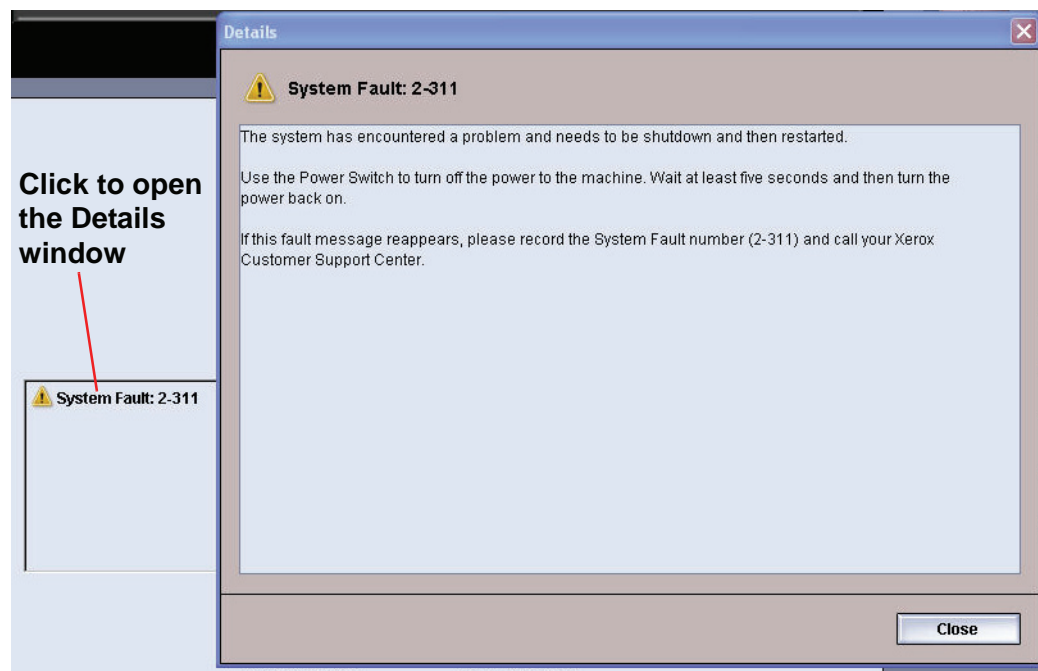

**NOTE:** The automatically opening of this Details window can be changed. For more information, refer to Chapter 2 of the Administrator Guide.

## Tray status area

---

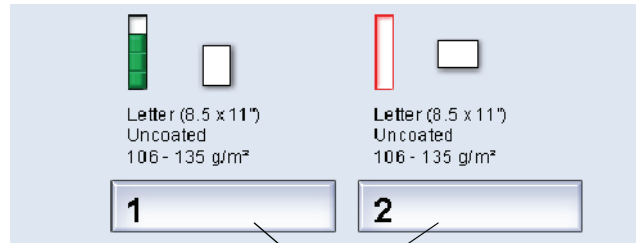

**Click to open the Tray Properties window**

This area of the UI displays the paper trays and their status, including which tray is currently in use during a print job. The number of paper trays shown depends on your machine's configuration.

By clicking on a tray button, the Tray Properties window opens. Refer to Chapter 2 Tray Properties for more information on this feature.

## Main control buttons

---

### Logon and current User level

---

There are two logon levels:

- **Operator:** This is the default logon level.
- **Administrator:** This level allows you to customize the system defaults for your machine. This level also allows you to customize particular print jobs by creating, setting, or changing parameters for certain features.

Refer to Chapter 1 of the Administrator Guide for more information on this feature.



## Current User Level

The current User Level is displayed on the upper right side of the UI screen:



## Language

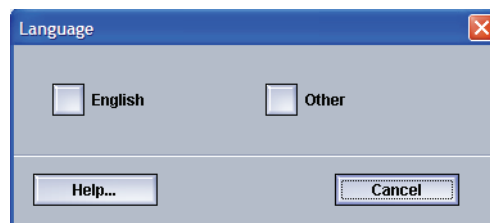

The Language window changes the language on the UI. The UI is capable of storing a maximum of eight (8) languages, all of which are simultaneously available upon the user's request.



**NOTE:** The number of languages available on your system depends on what was installed during the initial installation process.

Selecting a particular Language button immediately changes the language. No confirmation is required.

If fewer than eight languages are available on your UI, the position of the buttons change accordingly.



To change the language, use the following procedure.

1. Select the **Language** button on the UI.
2. Select the desired language button; the language on the UI changes to the new language and closes the Language window.
3. Select the **Cancel** button to return to the main UI screen.

## Power Saver

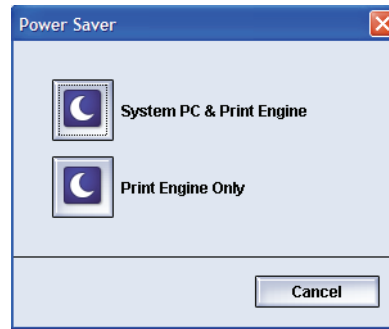

Pressing the Power Saver button displays the Power Saver screen. There are two Power Saver modes:

- **System PC & Print Engine:** Selecting this option places both the digital press and the System PC in power saver mode.
- **Print Engine Only:** Selecting this option places only the digital press in power saver mode.

The Power Saver mode reduces power consumption mode during which the Fuser temperature is lowered. The digital press automatically goes into this mode after no activity occurs for the factory default time of fifteen minutes. This time can be changed to reflect a value of 1-240 minutes; you must enter the Administrator mode to change it.

The digital press and/or System PC exits the Power Saver mode when a job is sent to be printed or the UI on the System PC is activated.



**NOTE:** To manually exit Power Saver mode, press the Power Saver button on the System PC.

Refer to the Power Saver section in Chapter 2 of the Administrator Guide for more information on this feature.

## Pause

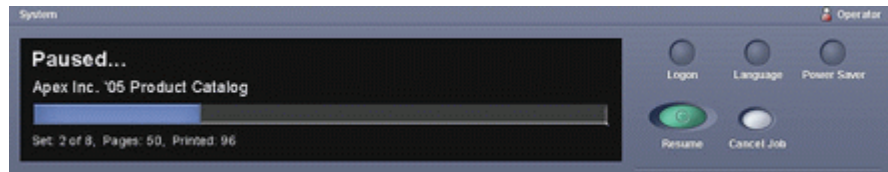

Selecting the **Pause** button during a print job stops or pauses the printing process. Once a print job is paused, you may choose either:

- **Resume:** Selecting this option resumes the print job from the point it was paused.
- **Cancel Job:** Selecting this option displays a secondary window asking the user if they want to cancel the print job.
  - Selecting **Yes** cancels the printing process.
  - Selecting **No** closes the **Confirm Cancel Job** window and returns the machine to the paused state. You must select **Resume** to continue the printing process.



**NOTE:** Depending on the Administrator setting, your machine may automatically resume printing after a preset period of time without selecting the Resume button. Ask your Administrator about this or refer to Chapter 2 of the Administrator Guide for more information.

## Dry Ink/Toner status area



This area of the UI displays the status of the dry ink/toner cartridges with a gauge indicating the level/amount of toner for each cartridge. As toner is used, the display continually updates the gauge for each toner cartridge.

For example, the gauges for the dry ink/toner cartridges indicate the amount of toner in each cartridge:

- The cartridge is 100% full when all four bars are filled with its appropriate color (as indicated in the illustration with Yellow).
- The cartridge is 75% full when three bars filled (as shown with Cyan).
- The cartridge is 50% full when two bars are filled in (as shown with Magenta and Black 2).
- The cartridge 25% full when one bar is filled in (as shown with Black 1).

The five dry ink/toner cartridges are Customer Replaceable Units (CRUs). Each cartridge is also equipped with a CRUM (Customer Replaceable Unit Memory) monitor. The CRUM is a wireless system that monitors and stores information about the dry ink/toner cartridges, including the following:

- Characteristics of the dry ink/toner cartridges which guarantee the number of prints described in the user specifications
- Information that guarantees image quality
- Information which allows it to detect the life span of each cartridge
- Maintaining a usage log for each color for reference at the time of collection by the customer and the service representative
- Preventing erroneous insertion of a different dry ink/toner cartridge
- Managing the number of times cartridge is removed and reinstalled, and finally
- Detecting the replacement of a used cartridge with a new one

### Operator/Administrator buttons

---

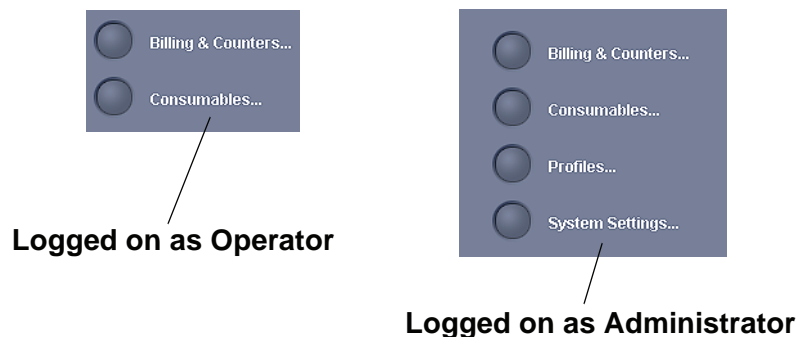

This area of the UI displays the Operator/Administrator buttons. Depending on the current user status, the features shown here will vary:

- If you are logged on as Operator, these features are available:
  - Billing & Counters
  - Consumables
- If you are logged on as Administrator, in addition to Billing & Counters and Consumables, these features are also available:
  - Profiles
  - System Settings



**NOTE:** Refer to Chapter 2 System Settings and Chapter 3 Profiles of the Administrator Guide for more detailed information on System Settings and Profiles.

## Billing & Counters

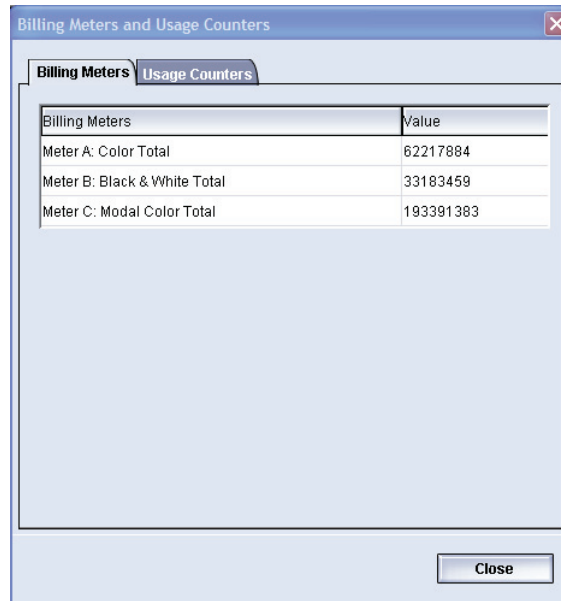

The screenshot shows a window titled "Billing Meters and Usage Counters" with two tabs: "Billing Meters" (selected) and "Usage Counters". The "Billing Meters" tab displays a table with the following data:

Billing Meters	Value
Meter A: Color Total	62217884
Meter B: Black & White Total	33183459
Meter C: Modal Color Total	193391383

A "Close" button is located at the bottom right of the window.

This screen displays the **Billing Meters** and **Usage Counters** information:

- The Billing Meters screen keeps track of total number of prints, and the information displayed may vary from market place to market place. These meters *cannot* be reset.
- The Usage Counter screen works the same way as a trip odometer in a car. It can be reset to zero. Once it is reset to zero, it keeps track of the print count from that point forward until you select the Reset All button.

The information displayed on this screen may vary from market place to market place.

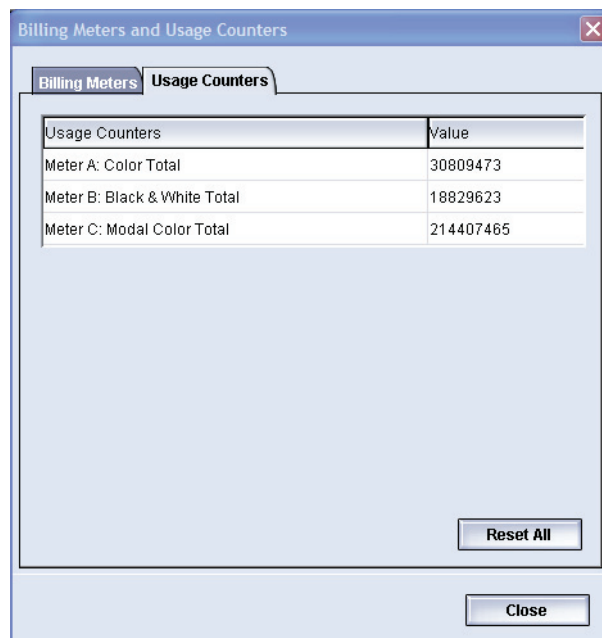

The screenshot shows the same window with the "Usage Counters" tab selected. The table displays the following data:

Usage Counters	Value
Meter A: Color Total	30809473
Meter B: Black & White Total	18829623
Meter C: Modal Color Total	214407465

A "Reset All" button is located at the bottom right of the table area, and a "Close" button is at the bottom right of the window.

To reset the meters to zero, select the **Reset All** button.

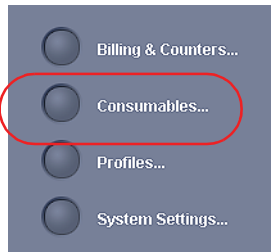

## Consumables

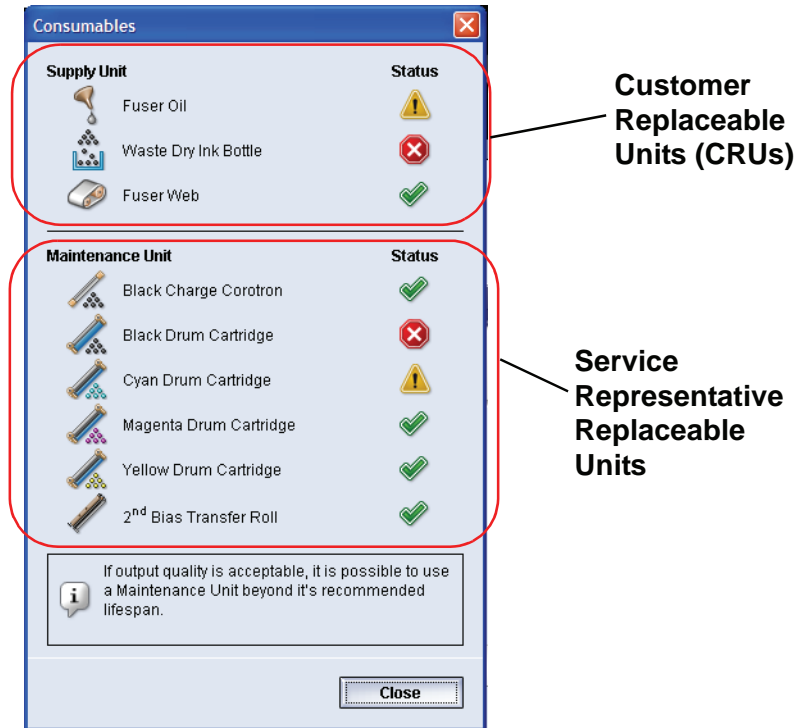

Selecting the Consumables button opens a window which displays a status of each consumable. The Consumables screen is divided into two sections as shown in the following illustration:



The status of a consumable is represented by:

- A yellow triangle (  ) indicating that the level is low
- A red circle (  ) indicating that the consumable is depleted or at its limit
- A green check mark (  ) indicating that the level of the consumable is adequate



**NOTE:** When a **Customer Replaceable Unit (CRU)** consumable item is depleted, the digital press automatically interrupts the current job and does not restart until the consumable is replaced.



**TIP:** The digital press does not interrupt a job or stop running if a Service Representative Replaceable Unit status indicates a low or depleted level. Your Service Representative Replaceable Unit may continue to perform as expected far beyond the average life indicator. Your Service Representative uses this status indicator information each time service is performed on your machine.

## Administrator buttons

---

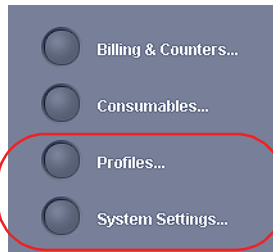

If you are logged as Administrator, the **Profiles** and **System Settings** features are available to you.

- The **Profiles** feature allows you to create customized procedures for your work/printing environment. These customized procedures include Alignment, Custom Paper, and Decurler.

Refer to Chapter 3, Profiles in the Administrator Guide for more detailed information on each of the Profiles features.

- The **System Settings** feature allows you to make changes to the following:
  - User Interface
  - Date and Time
  - System
  - Tray Options

Refer to Chapter 2 System Settings in the Administrator Guide for more detailed information on each of the System Settings features.

## Relocating the digital press

---

If you need to relocate the digital press, call your Xerox customer representative. The Installation Planning procedure must be conducted for every new site.

## Customer documentation updates

---

You can get the latest customer documentation and information for your product by going to [www.xerox.com](http://www.xerox.com) and doing one of the following:

- Enter your product number (e.g., DocuColor 5000) in the Search field and select **Search**.
- Select the **Support & Drivers** link and then use the search options to locate your specific printer.

Be sure to periodically check [www.xerox.com](http://www.xerox.com) for the latest information for your product.



---

## 2. Tray Properties

### Overview

---

The Tray Properties window allows you to set the parameters for the paper that is loaded in the tray.

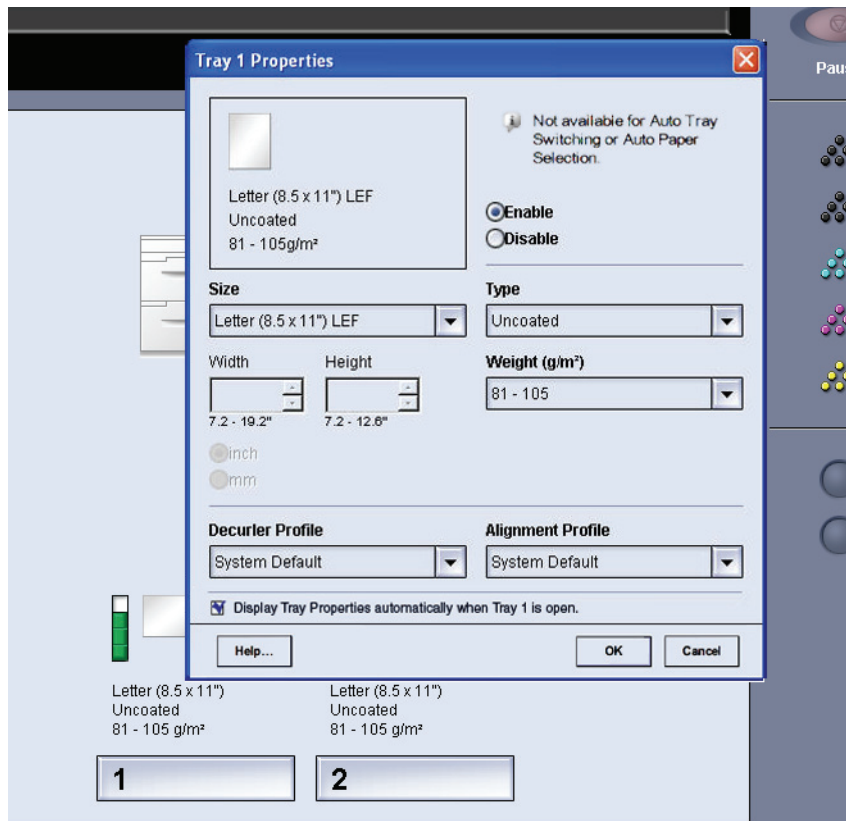

## Tray Properties window

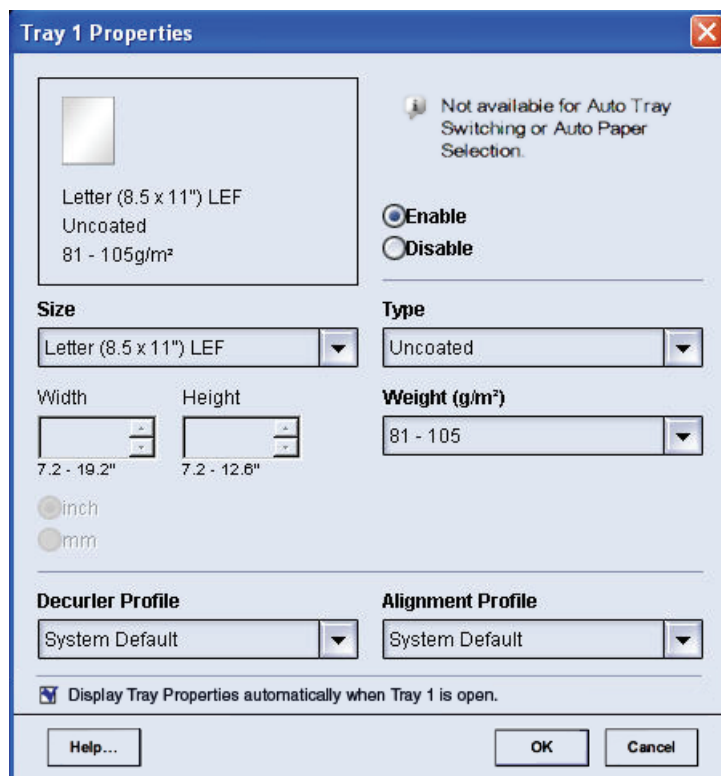

From the Tray Properties window you can make various paper selections, such as size or customer size (width and height), type, weight, and more. Each area of the Tray Properties screen is discussed in more detail on the following pages.

## Current tray information

---

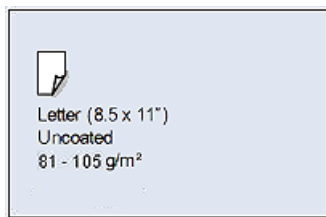

This area of the Tray Properties screen displays the current tray information including the paper size, type, weight, and orientation of the paper (LEF or SEF).

## Not available for...

---

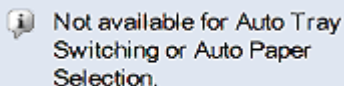

This area of the screen displays whether a tray is available for Auto Tray Switching (ATS) or Auto Paper Selection (APS). The tray's availability for either of these features is determined in System Settings.

## Auto Tray Switching

---

When Auto Tray Switching (ATS) is activated in the System Settings of the Administrator mode, the digital press automatically switches to another tray containing paper of the identical size, weight, type, and feeding orientation (SEF or LEF) when the tray being used is empty.

## Auto Paper Selection

---

Auto Paper Selection (APS) can be enabled in the System Settings of the Administrator mode. When enabled, the digital press automatically selects the paper tray containing the correct size paper without a specific paper tray being selected.

Refer to the Administrator Guide for more information on ATS and APS.

## Enable/Disable

---



This area of the screen allows you to enable or disable a specific tray for use. If **Enable** is selected, the paper tray is available for use by the machine. If **Disable** is selected, the paper tray is disabled and is not available for use by the machine.

### Size

---

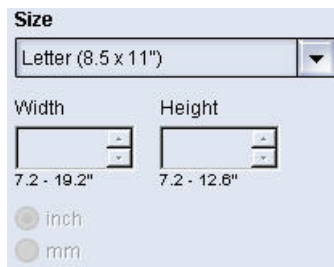

This area of the screen displays the size of the paper that is currently loaded in the tray. The information shown here includes the width and height of the paper and/or any custom paper size information. You can select a different paper size from the pull-down menu.

### Custom Paper Size

---

You can run custom (nonstandard) sized paper from any paper tray by selecting **Custom** from the **Size** pull-down menu and entering the specific paper size information for the tray being used.

### Type

---



This area displays the type of paper that is currently loaded in the tray. You can select a different type from the pull-down menu.

**NOTE:** *If one or more Custom Paper Profiles have been created, these profiles are available for selection from this pull-down menu. Refer to the Administrator Guide for more information on Custom Paper Profiles.*

### Weight

---



This area of the screen displays the weight of the paper currently loaded in the tray. You can change the weight from the pull-down menu. If custom paper profiles have been created, these profiles are listed and accessible for selection from the pull-down menu.

## Decurler Profile

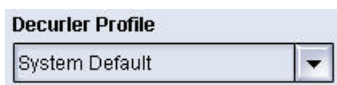

This area of the screen allows you to select a specific Decurler profile or the system default from the pull-down menu.

Your system is designed with several automated settings to control curl. When using these settings the machine automatically sends paper through the proper Decurler:

- System Default: Automatically determines the amount of pressure needed at the different Decurlers in order to reduce the output curl of the paper.
- A, B, C, and D settings: Preset Decurler settings, which are manually selected as an alternative to the System Default setting.

To select a Decurler Profile:

1. Select the tray that contains the job stock, which requires curl control. For this exercise, select **Tray 1**.

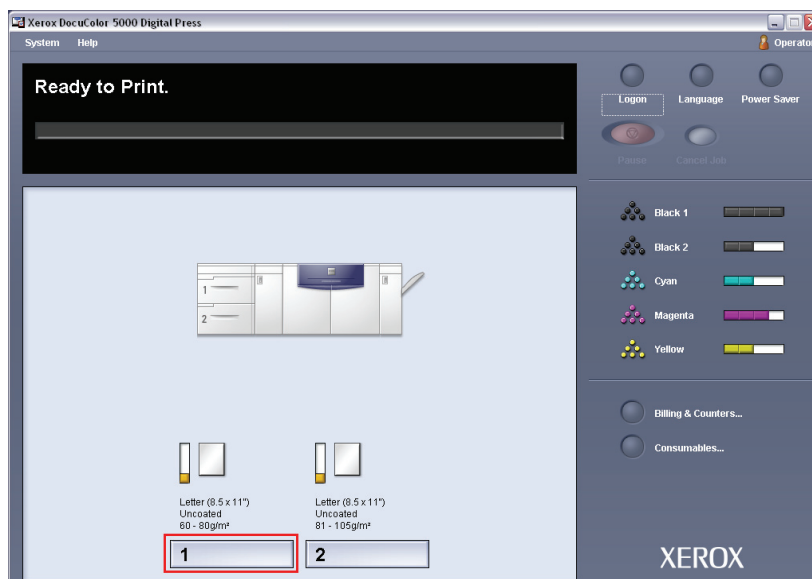

- From the Decurler Profile menu, select the Decurler Profile that you want to use and then select **OK**.

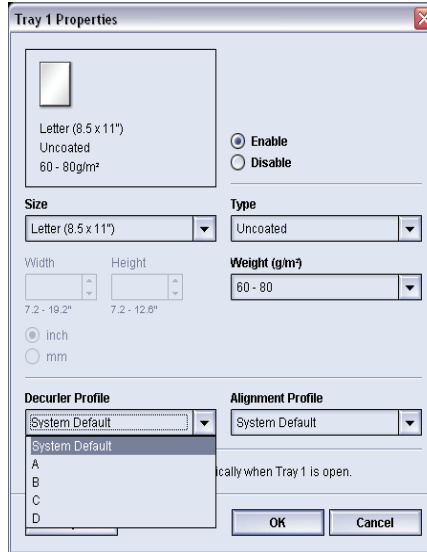

**NOTE:** If a Decurler profile is changed, it remains at that setting until changed again manually. As an example, if you decide to use the B Decurler setting, the setting will remain at B until you change it to another setting.

**NOTE:** With some print jobs, the output prints still may be curled more than you desire even after using the Decurler A-D Settings. In those cases, use the Custom Decurler Profile feature to compensate for paper curl in your prints. For additional information on the Decurler and the step-by-step instructions on using it, Chapter 3 of the Administrator Guide, which is located on your Customer Documentation CD or at [www.xerox.com](http://www.xerox.com).

## Alignment Profile



This area of the screen allows you to select a specific alignment profile or the system default from the pull-down menu.

Refer to the Administrator Guide for more detailed information on each of the Profiles features.

## Display...

Display Tray Properties automatically when Tray 1 is open.

If this box is checked, the Tray Properties window opens whenever the tray is open.

## Help button

Click the Help button to obtain more detailed information on the various Tray Properties features.

## Selections made on the Tray Properties window

The screenshot shows the 'Tray 1 Properties' dialog box with the following settings:

- Paper Properties:** Letter (8.5 x 11") LEF, Uncoated, 81 - 105g/m<sup>2</sup>
- Size:** Letter (8.5 x 11") LEF (Width: 7.2 - 19.2", Height: 7.2 - 12.6")
- Type:** Uncoated
- Weight (g/m<sup>2</sup>):** 81 - 105
- Decurler Profile:** System Default
- Alignment Profile:** System Default
- Auto Tray Switching:** Not available for Auto Tray Switching or Auto Paper Selection. **Enable** is selected.
- Display Tray Properties automatically when Tray 1 is open:** Checked.



**TIP:** Selections made to any of the Tray Properties features remain at those specific settings until changed again manually.

## 2. Tray Properties

---

For example, if you decide to change the Decurler Profile setting from **System Default** to **A** (as shown in the following illustration), setting **A** remains in effect until you change it to another setting. This is important to remember when preparing your job for printing. Ensure that all your desired options are selected from the Tray Properties window before printing your job.

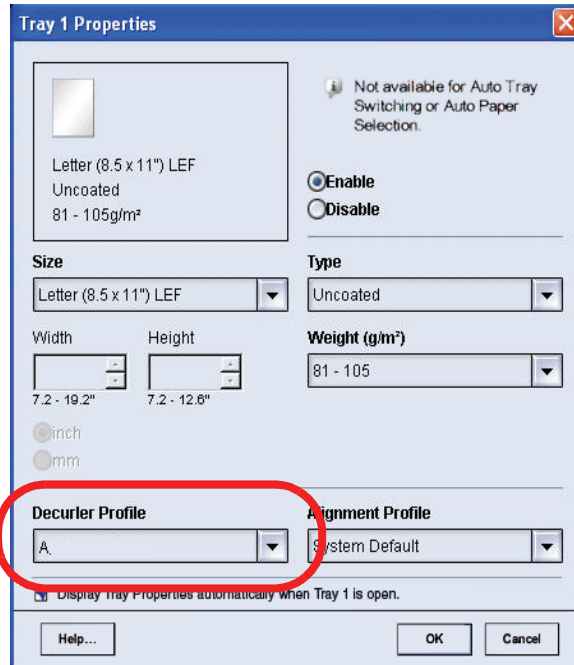

## Basic paper information

---

Refer to Chapter 3 Paper information for basic paper information such as:

- Paper handling
- Paper guidelines, including:
  - Paper specifications
  - Tabbed guidelines
  - Transparency guidelines
  - Drilled paper guidelines for 1-sided and 2-sided print jobs
- Paper weight conversion tables
- Loading paper in the paper trays
- Paper trays air adjustment
- Paper Tray Stock Mismatch information



---

## 3. Paper information

---

### Recommended Materials List (RML)

---

Refer to the *Recommended Materials List* and the *Speciality Media Guide: Hints and Tips* for paper guidelines. The *Recommended Materials List* and the *Speciality Media Guide: Hints and Tips* documents are updated on an on-going basis to include new papers and other media. PDF files are available at [www.xerox.com](http://www.xerox.com). Use the search parameter DocuColor 5000AP and follow the path until you reach the files to download.

---

### Paper handling

---



**NOTE:** Many suppliers use arrows on the product labels to indicate the preferred side to image first. Use this side (as signaled by the arrow) as equivalent to the seam side when loading the paper.

Label on the ream instructs you to “Print arrow side first”



For the best performance, load paper with the seam side up in all the paper trays. The seam side is where the ream of paper is sealed. Refer to the label on the paper ream.

Many factors affect the performance of paper, including room temperature, humidity, paper quality, dust, and the size of the image area. If jams or paper curl problems occur, remove the paper from the paper tray, turn it over, place it back in the paper tray, and resume printing. If the problem is rectified, continue to load your paper in the same manner.

If the problem is not rectified, load a new ream of paper and try the process again. If the problem persists, your Administrator may go into the Administrator mode and try the different Decurler settings.



**NOTE:** Decurler Profile settings Default and A-D are available to the user. See, Chapter 2 Tray Properties for additional details. For additional information on the Decurler and the step-by-step instructions on using it, Chapter 3 of the Administrator Guide, which is located on your Customer Documentation CD, or at [www.xerox.com](http://www.xerox.com).

If, after trying all the previous suggestions, the problem still persists, call your Xerox representative.

For reliable digital press operation and good print quality, Xerox recommends the following:

- Stored paper:**
- On a flat surface. Do not store paper directly on the floor, since this increases the possibility of moisture absorption. Paper should be stored on pallets, shelves, or in cabinets in an area protected from extremes of temperature and humidity.
  - In a low dust area.
  - In a low humidity area. Humidity is one of the most important steps to promote proper paper characteristics. Optimum paper storage conditions include a relative humidity of 35-55%. An increase in humidity may cause paper to develop wavy edges. This occurs because the edges absorb moisture while the rest of the ream remains unaffected. Wavy edges causes jams and misfeeds.
  - In an air-tight, moisture-proof container.
  - In a controlled temperature. The temperature in the room where paper is stored has a significant effect on how that paper performs in the machine. Optimum paper storage temperature is 68-76° F (20-24.4° C).

#### **Cutting and trimming paper**

Proper cutting of the paper is important. Mills that offer paper in “cut sizes” crop their papers using state-of-the-art rotary slitters on high performance systems. Slitting and edge trimming by circular knives with dust removal at every cutting point prevents contamination of the paper.

Trimming papers from parent sheets to get the desired output size may generate dust if dull knives are used. The recommendation is to delay trimming until printing has been finalized to prevent paper dust generation and contamination.

If pre-printing is imperative, an in-house maintenance program, including knife sharpness maintenance and dust removal with a vacuum or air system, are key to achieving good results.

## Paper guidelines

For the best results, remember the following:

- Do not load paper or other materials above the **MAX** line on the rear paper guide.
- Do not store extra reams of paper in the paper trays.
- Do not use wrinkled, torn, curled, or folded paper.
- Use the paper sizes and weights shown in the *Recommended Materials List*.
- Follow the suggestions in the *Specialty Media Guide: Hints and Tips*.
- Do not mix sizes or weights of paper in a paper tray.
- Ensure that the tray is set for the correct paper size, weight range, and paper type.

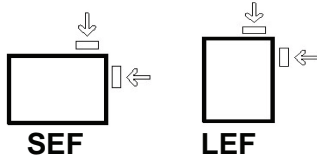

Copy paper is fed into the digital press in one of two positions: long edge feed (LEF) or short edge feed (SEF). Long edge refers to the long edge of the paper. When you see LEF, position the paper so the long edge is fed first. Short edge refers to the short edge of the paper. When you see SEF, position the paper so the short edge is fed first.



**NOTE:** It is imperative that you load paper with the paper guides adjusted properly. If the paper is NOT loaded properly, it skews and jams occur.

## Curl

---

When paper is exposed to heat, the paper loses moisture and curls toward the heat source. High toner coverage jobs tend to curl more than low toner coverage jobs. The system tries to reduce this by using mechanical devices within the paper path called Decurlers.

Paper curl is caused by many variables, including, but not in any particular order:

- The weight of the paper and whether it is coated or uncoated.
- The amount of dry ink/toner and the area being covered on a sheet: the heavier the coverage, the greater the tendency to curl.
- How the paper is loaded in the tray. Make sure you load the paper as instructed on the ream wrapper.
- The atmospheric conditions of the room where the paper is stored and where the printer is located, especially those related to humidity and temperature.
- The heat generated during the fusing processes.



**NOTE:** If the curl is excessive, use the Decurler Profile settings Default and A-D, which are available to the user. See, [Chapter 2 Tray Properties](#) for additional details. For additional information on the Decurler and the step-by-step instructions on using it, Chapter 3 of the Administrator Guide, which is located on your Customer Documentation CD, or at [www.xerox.com](http://www.xerox.com).

## Paper specifications

Paper	All Paper Trays	
Minimum Paper Size	182mm x 182mm (7.2 x 7.2")	
Maximum Paper Size	320mm x 488mm (12.6 x 19.2")	
Standard Sizes	B5 LEF/SEF B4 SEF 8 x 10" LEF/SEF 8.5 x 13" SEF 11 x 17" SEF 12.6 x 17.7" SEF <sup>(1)</sup> SRA3" (320 mm x 450mm) SEF	A4 LEF/SEF A3 SEF 8.5 x 11" LEF/SEF 8.5 x 14" SEF 12 x 18" SEF 12.6 x 19.2" SEF <sup>(1)</sup>
Paper Weight Range	60 - 300 g/m <sup>2</sup> (16 lb bond - 110 lb cover)	
Transparencies <sup>(2)</sup>	Yes (A4 LEF or 8.5 x 11" LEF)	
Labels <sup>(2)</sup>	Yes	
Transfer Paper <sup>(2)</sup>	No	
Coated Paper (120 g/m <sup>2</sup> /80 lb) <sup>(3) (4)</sup>	Yes	
Uncoated Paper (90 g/m <sup>2</sup> /24 lb)		
Tabbed Inserts <sup>(5)</sup>	Yes	
Drilled (LEF)	Yes: 2, 3, 4 hole	
Carbonless paper	Yes	

<sup>(1)</sup>Refer to the "Custom (nonstandard) size paper" on page 3-8.

<sup>(2)</sup>Refer to the *Recommended Materials List* and the *Speciality Media Guide* for guidelines.

<sup>(3)</sup>Duplex is limited to paper that is 220 g/m<sup>2</sup> or less.

<sup>(4)</sup>L80 g/m<sup>2</sup> cannot duplex in high humidity. L85 g/m<sup>2</sup> coated media is not allowed.

<sup>(5)</sup>Refer to the "Tabbed inserts" on page 3-6.

#### Transparency guidelines

---

Transparencies can be run from all the paper trays.

Use only the transparencies recommended:

- Xerox Removable Paper Stripe: USA and Canada, 3R5765; Xerox Europe, 003R91331.

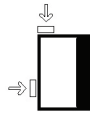

- Load transparencies into a tray with the paper stripe side facing DOWN and with the stripe as the leading edge. (The leading edge is the edge that feeds into the digital press first.)
  - Do not mix paper and transparencies in a tray. Jams may occur.
- Ensure that Transparency is selected in the Paper Weight section at the top/front of the paper tray.

#### Tabbed inserts

---

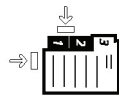

Tabbed Inserts can be loaded into the paper trays as Non-Standard paper.

- When loading, the non-tabbed, short edge of the tabbed insert should be the lead edge to the digital press.
- If a jam occurs while running tabbed sets, there is no recovery procedure.
  - You have to manually reassemble your originals and prints, determine where the job left off, and resume printing or cancel the job and start again.
- The size of the tabbed insert should be 9 x 11 inch (229 x 279 mm) for letter size tabs (223.5 x 296 mm for A4 equivalent tabs).
  - The correct weight of the insert should be selected on the tray.
- Select Custom size on the Tray Properties screen, input 11 inches or 296 mm for A4 as the width and 9 inches or 223.5 mm for A4 as the height for SEF.

Refer to the Administrator Guide for the procedure to program custom size paper.

## Drilled paper

Three-hole drilled paper can be run from all the trays either LEF or SEF with the holes facing any direction.



**NOTE:** If you are stapling 3-hole drilled paper with the optional Common Stacker Stapler (CSS), refer to Chapter 4 Accessories for paper loading instructions based on the position of the staple.

Drilled paper should be run in the Simplex (1-sided) and Duplex (2-sided) orientations shown below to avoid paper jams caused by the holes not aligning correctly with the paper sensor in the press.

### 1-Sided Print Jobs

Load the drilled paper into any tray in the Long Edge Feed (LEF) direction. Refer to the following illustration:

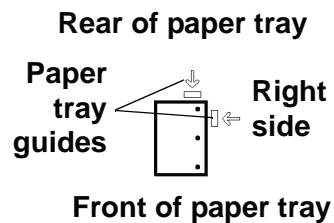

### 2-Sided Print Jobs

Load drilled paper into any tray in either the Long Edge Feed (LEF) or Short Edge Feed (SEF) direction. Refer to the following illustration:

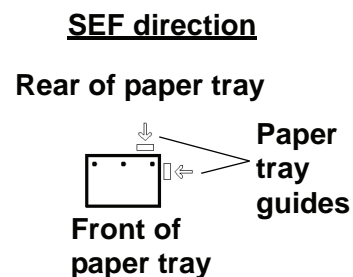
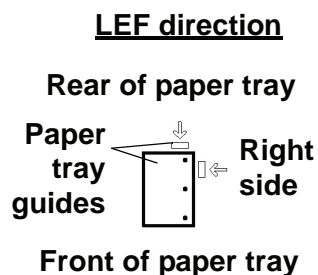

**NOTE:** If you are stapling 3-hole drilled paper with the optional Common Stacker Stapler (CSS), refer to Chapter 4 Accessories for paper loading instructions based on the position of the staple.

#### Letterhead

---

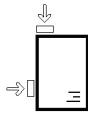

Different inks and dry inks/toners are used to produce preprinted letterhead that may not pass through the digital press intact.

*Refer to the Specialty Media Guide: Hints and Tips for information on using preprinted letterhead paper.*

#### Custom (nonstandard) size paper

---

Custom (nonstandard) size paper is identified as any paper for which there is no paper guide setting within the minimum and maximum sizes for the trays: 7.2 to 12.6 inch LEF or 7.2 to 19.2 inch SEF (182 - 320 mm LEF or 182 x 488 mm SEF)

Custom size paper can be loaded into all the trays. The Custom setting must be selected on the top/front of the paper tray.

Refer to the Administrator Guide for the procedure to program custom size paper.



## Paper weight conversion tables

### Specific weight conversion

Grammage (g/m <sup>2</sup> )	Xerographic Bond, Writing, pounds 17 x 22" - 500 sheets	Offset, Text, Book, pounds 25 x 38" - 500 sheets	Cover, pounds 20 x 26" -500 sheets	Index, pounds 25.5 x 30.5" - 500 sheets	Bristol and Tag, pounds 22.5 x 28.5" - 500 sheets
60	16	41	22	33	27
64	17	43	24	35	29
75	20	50	28	41	34
80	21	54	30	44	36
90	24	60	33	50	41
105	28	70	39	58	48
120	32	80	44	66	55
135	35	90	50	75	62
150	40	100	55	83	67
158	42	107	58	87	72
163	43	110	60	90	74
176	47	119	65	97	80
200	53	135	74	110	91
203	54	137	75	112	93
216	57	146	80	119	98
220	59	149	81	122	100
259	66	169	92	140	114
280	74	189	104	155	128
300	74	189	104	155	128

 Yellow shading indicates grades widely used for this classification

### Weight conversion ranges

<b>Grammage (g/m<sup>2</sup>)</b>	<b>Xerographic Bond, Writing, pounds 17 x 22" - 500 sheets</b>	<b>Offset, Text, Book, pounds 25 x 38" - 500 sheets</b>	<b>Cover, pounds 20 x 26: - 500 sheets</b>	<b>Index, pounds 25.5 x 30.5" - 500 sheets</b>	<b>Bristol and Tag, pounds 22.5 x 28.5" - 500 sheets</b>
60 - 80	17 - 21	43 - 54	24 - 30	35 - 44	29 - 36
81 - 105	22 - 28	55 - 70	31 - 39	45 - 58	37 - 48
106 - 135	29 - 36	71 - 90	40 - 44	59 - 75	49 - 62
136 - 150	37 - 40	91 - 100	45 - 55	76 - 83	63 - 67
151 - 220	41 - 59	101 - 149	56 - 81	84 - 122	68 - 100
221 - 300	60 - 74	150 - 189	82 - 110	123 - 166	101 - 128

## Loading paper



Use this procedure to load paper in any paper tray.



**NOTE:** Many suppliers use arrows on the paper ream labels to indicate the preferred side to image first. Use this side (as indicated by the arrow) as equivalent to the seam side when loading the paper.



**NOTE:** Opening the paper tray may cause the Tray Properties window to open automatically. This depends on whether or not the user has this option selected; refer to page 2-7 of this guide for more information.

- 1.** Pull out the tray slowly until it stops.
- 2.** Load the correct size paper into the tray in the correct feeding orientation.
  - Load the paper seam side (the side on which the ream of paper is sealed) up in all the trays.
  - Do not load materials above the MAX line located on the rear Edge Guide.
  - Do not store extra reams of paper in the open area of the paper trays. The tray will become inoperable until the paper is removed.
- 3.** Adjust the paper guides by pressing in the guide release and carefully moving the Edge Guide until it lightly touches the edge of the material in the tray.
- 4.** From the Tray Properties window, enter the correct paper information, including size, type, and weight, and if required, decurler profile and alignment profile selections.
- 5.** Select **OK** to save the information and close the Tray Properties window.
- 6.** Close the paper tray.
  - All the trays have auto size detection capability. The loaded paper size, weight, type, and orientation is displayed on the UI screen once the tray is closed.
  - Selecting the correct paper weight range affects the throughput performance and image quality.
  - Refer to the table on page 3-9 to convert pounds to grams.

#### Paper trays air adjustment:

---

Blowers help control the environmental conditions in the paper trays to ensure optimum print capability:

- Each paper tray has two blowers and two fans. The blowers are located in the front of each tray, while the two fans are located on the right-side of the tray.
- The lead edge blower is on at all times and produces heated air if one of the following selections are made: Coated paper, Transparencies, or plain paper 106 g/m<sup>2</sup> or heavier. The trail edge blower is on at all times and does not produce heated air.
- The paper trays also have air adjustment levers on the drawer to regulate the direction of the air.

If the paper weight is between 60 and 256 g/m<sup>2</sup>, the position of the air adjustment levers should be toward the front of the tray.

If the paper weight is between 257 and 300 g/m<sup>2</sup>, the position of the air adjustment levers should be positioned toward the rear of the tray.



## Tray Stock Mismatch

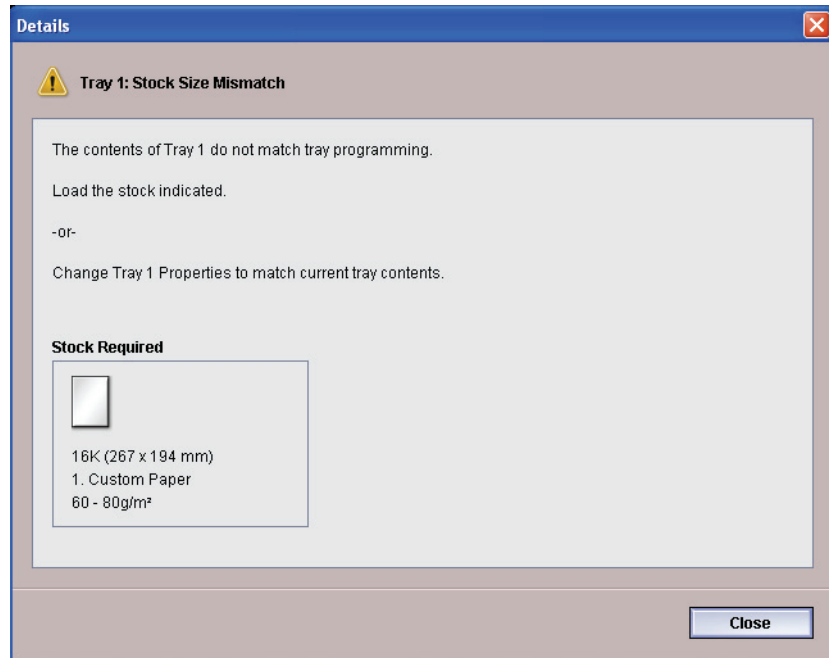

If the paper loaded in a tray does not match the information on the Tray Properties window, the UI alerts you with a Tray Stock Size Mismatch message. Also, if you receive a Tray Stock Size Mismatch message, check the paper tray guides to ensure that they are positioned correctly.



If you receive this message, do the following:

- 1.** Load the stock indicated on the Tray Stock Size Mismatch window, or
- 2.** Change the Tray Properties to match the contents of the tray.
  - a. Verify the paper size, type (coated, uncoated, etc.), and weight of the paper loaded in the tray.
  - b. Enter that information on the Tray Properties window.



---

## 4. Accessories

### Trays 3 and 4 (Second Feeder Module)

---

The Second Feeder Module is an optional feeding device that contains Trays 3 and 4. This module holds the same number and types of substrates as the First Feeder Module (FFM), which contains Trays 1 and 2. The First Feeder Module is not optional and is permanently connected to the digital press.

Each tray holds a maximum of 2000 sheets of 24 pound (90 g/m<sup>2</sup>) paper. Refer to “Paper guidelines” in Chapter 3 on page 3-5 for more information on using specific types of paper.



**NOTE:** Always refer to the Recommended Materials List and the Speciality Media Guide.

### Identifying the parts

---

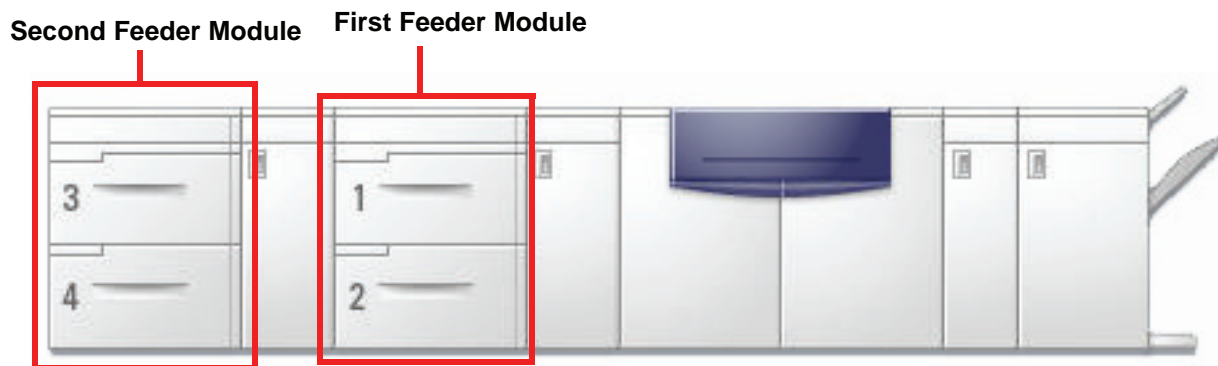

## Paper path

Paper feeds from the right side of the trays. Sheets move from the transport area behind the right door of the SFM to the Upper Transport area above Paper Trays 1 and 2, then through the Transport Module and into the press.

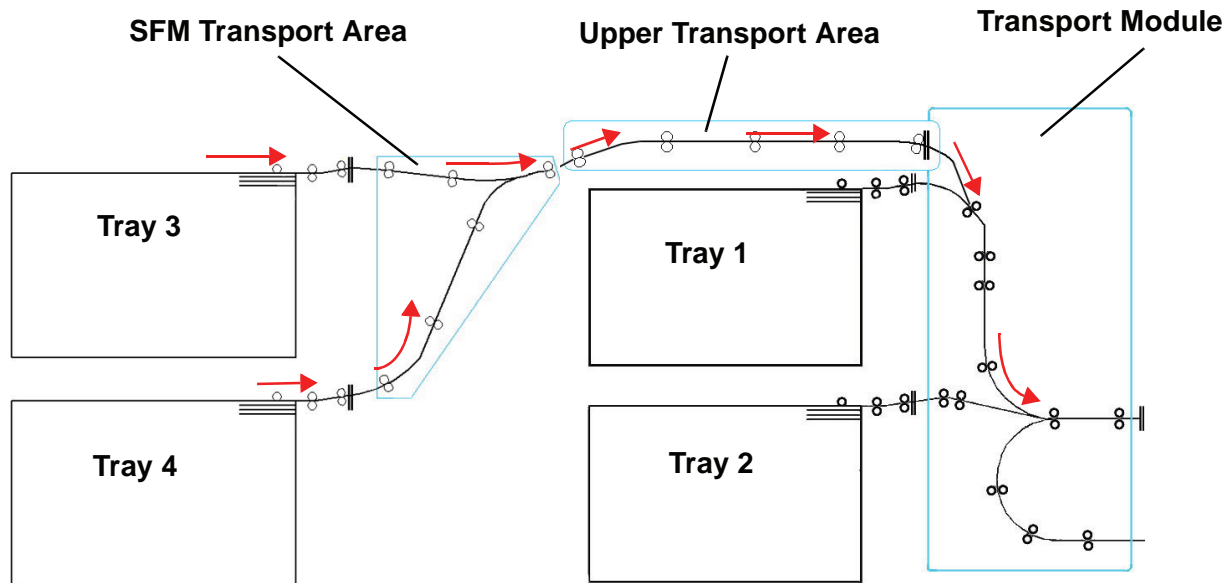

## Paper guidelines

For the best results, remember the following:

- Do not load paper or other materials above the MAX line on the rear paper guide.
- Do not store extra reams of paper in the paper trays.
- Do not use wrinkled, torn, curled, or folded paper.
- Use the paper sizes and weights shown in the *Recommended Materials List*.
- Follow the suggestions in the *Specialty Media Guide: Hints and Tips*.
- Do not mix sizes or weights of paper in a paper tray.
- Ensure that the tray is set for the correct paper size, weight range, and paper type.



**NOTE:** It is imperative that you load paper with the paper guides adjusted properly. If the paper is NOT loaded properly, it will skew and jams will occur.



## Paper Specifications

Paper	All Paper Trays	
Minimum Paper Size	182mm x 182mm (7.2 x 7.2")	
Maximum Paper Size	320mm x 488mm (12.6 x 19.2")	
Standard Sizes	B5 LEF/SEF B4 SEF 8 x 10" LEF/SEF 8.5 x 13" SEF 11 x 17" SEF 12.6 x 17.7" SEF <sup>(1)</sup> SRA3" (320 mm x 450mm) SEF	A4 LEF/SEF A3 SEF 8.5 x 11" LEF/SEF 8.5 x 14" SEF 12 x 18" SEF 12.6 x 19.2" SEF <sup>(1)</sup>
Paper Weight Range	60 - 300 g/m <sup>2</sup> (16 lb bond - 110 lb cover)	
Transparencies <sup>(2)</sup>	Yes (A4 LEF or 8.5 x 11" LEF)	
Labels <sup>(2)</sup>	Yes	
Transfer Paper <sup>(2)</sup>	No	
Coated Paper (120 g/m <sup>2</sup> /80 lb) <sup>(3) (4)</sup>	Yes	
Uncoated Paper (90 g/m <sup>2</sup> /24 lb)		
Tabbed Inserts <sup>(5)</sup>	Yes	
Drilled (LEF)	Yes: 2, 3, 4 hole	
Carbonless paper	Yes	

<sup>(1)</sup>Refer to the "Custom (nonstandard) size paper" on page 3-8.

<sup>(2)</sup>Refer to the *Recommended Materials List* and the *Speciality Media Guide* for guidelines.

<sup>(3)</sup>Duplex is limited to paper that is 220 g/m<sup>2</sup> or less.

<sup>(4)</sup>L80 g/m<sup>2</sup> cannot duplex in high humidity. L85 g/m<sup>2</sup> coated media is not allowed.

<sup>(5)</sup>Refer to the "Tabbed inserts" on page 3-6.

### Loading paper

---

Loading paper in Trays 3 and 4 is the same as it is for Trays 1 and 2; therefore, use the same procedure for loading paper. Refer to page 3-11 for the procedure.

### Paper trays air adjustment

---

Blowers help control the environmental conditions in the paper trays to ensure optimum print capability. For additional information, see “Paper trays air adjustment:” in Chapter 3 on page 3-12.

### Jam clearance

---

A paper jam anywhere in the digital press is indicated by a message on the UI. Follow the instructions displayed to clear the jam in the area or areas displayed on the screen and to resume printing. Additional jam clearance instructions are also provided in Chapter 5 on page 5-5.

### Physical characteristics

---

#### Size

---

41.7 inches/1060 mm W x 29.5 inches/750 mm D x 38 inches/969 mm H.

#### Weight

---

551 pounds/250 Kg.

#### Floor space requirements

---

Ask your Xerox representative to refer to the *Installation Planning Guide* for installation work space requirements.

## High Capacity Stacker

The High Capacity Stacker (HCS) is an optional finishing device that provides stacking and offsetting capabilities for output to the HCS Stacker Tray. The HCS connects to the right side of the digital press and replaces the Offset Catch Tray.



The HCS Stacker Tray has a capacity of 3500 sheets of 24 lb (90 g/m<sup>2</sup>) centerline paper (or 370 mm high). The HCS Top Tray has a capacity of 250 sheets of 24 lb 90 gm<sup>2</sup> centerline paper. The HCS is supplied with two Stacker Carts. If needed, you can purchase an additional Stacker Cart. Contact your Xerox representative for further details.



**NOTE:** *The Stacker Tray cannot support more than 99 lb. (45 kg) of printed material and therefore, cannot hold 3500 sheets of coated paper (for example SRA3).*

With the HCS you can:

- Select Offset Mode when collated sets are sent to the Stacker Tray.
- Send documents to the top tray.
- Send sets of different sizes to either the Stacker Tray or the top tray.



**NOTE:** *To avoid jams, do not stack larger sets on top of smaller sets, or stack paper on top of transparencies.*

- Send a sample set to the top tray.
- Chain two High Capacity Stackers to the digital press and send collated sets to HCS 1, HCS 2 or both High Capacity Stackers.
- Send collated sets through the stacker to another connected finishing device.

## Identifying the parts

### Control panel

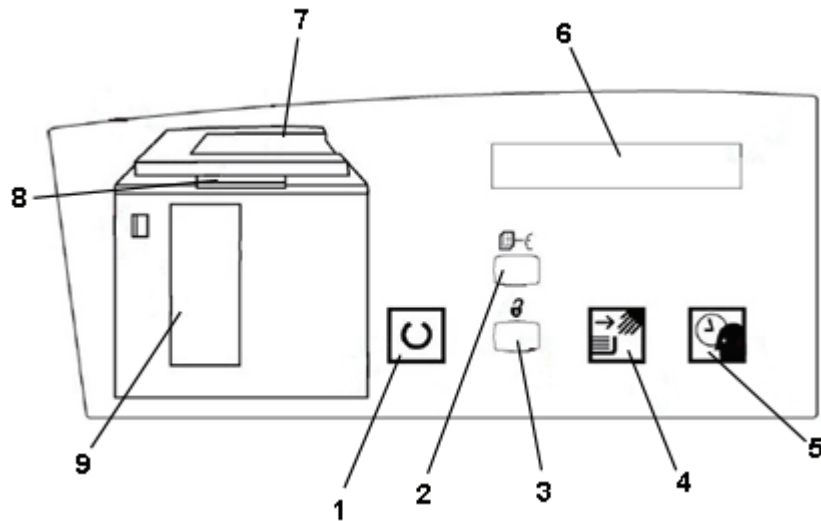

Item Number	Name	Function
1	Ready light	The Ready light blinks during initialization and is constant when the HCS is in use or in standby mode.
2	Sample set button	Press to have the HCS deliver the next collated set to the top tray.
3	Unload button	Press once to lower the Stacker Tray and unlock the front door. If pressed while running a job, all sheets in the paper path are delivered before the Stacker Tray starts to lower.
4	Unload light	Illuminates when the Stacker Tray has reached the down position and the front door can be opened.
5	Wait light	Blinks when the Stacker Tray is moving up or down.
6	Fault code display	Displays a code when a fault occurs in the stacker. Refer to the HCS fault code table located in the Problem Solving section of this chapter.
7	Top tray jam area	Blinks when there is a jam. Illuminates when output is sent to the tray.
8	Bypass jam area	Blinks when there is a jam.
9	Stacker tray jam area	Blinks when there is a jam or the door is open. Illuminates when output is sent to the tray.
Not applicable	Keypad (not shown)	Used by the service representative for diagnostics. The keypad is located on the front right of the control panel.

## Cooling fan

The stacker is equipped with a cooling fan that you can switch on and off as required. The cooling fan is located inside the front door:

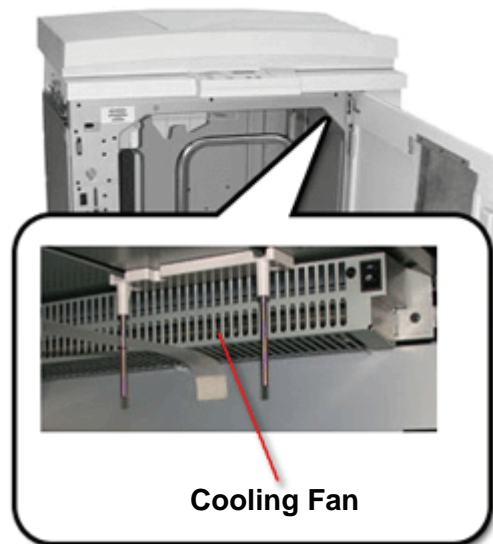

The cooling fan is normally **Off**. The fan must be switched **On** when you are using coated paper than weighs  $120 \text{ g/m}^2$  (80 lb.) or greater.

For coated paper than weighs less than  $120 \text{ g/m}^2$  (80 lb.) and for uncoated paper, the fan should be switched **Off**.



To switch **On** the cooling fan, perform the following steps:

1. Push the Unload button to lower the tray.
2. Open the front door.



3. Press the cooling fan power switch to the **On** position.

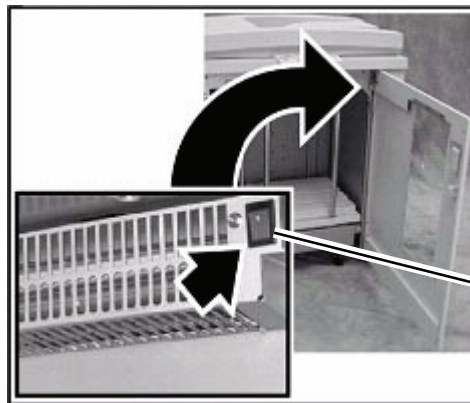

Power switch



**TIP:** Only switch on the cooling fan when running paper that weighs 120 g/m<sup>2</sup> (80 lb.) or greater.



**NOTE:** Remember to switch off the fan after your job(s) finishes and when running paper that weigh less than 120 g/m<sup>2</sup> (80 lb.).

## Paper path



**TIP:** Labels must be sent to the HCS Top Tray.

### Top Tray

Sheets are transported to the HCS Top Tray:

- When sheets are purged after a paper jam.
- When the Sample Set button is selected.
- When selected as an Output Location.

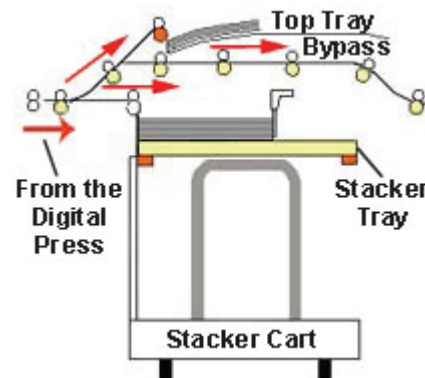

### Stacker Tray

Collated sets are transported to the HCS Stacker Tray.

### Bypass

The Bypass transports collated sets through the HCS to a connected finishing device or to another HCS.

If your system configuration has two High Capacity Stackers, the bypass on the second HCS is not available.

### **Paper guidelines**

---

- The HCS Stacker Tray accepts 60-300 g/m<sup>2</sup> (either coated or uncoated stock) with the possibility of degraded stock quality and increased jam rate
- Transparencies may be run to either the HCS Top Tray or the HCS Stacker Tray. Stack height should be limited to 100 transparencies.
- Coated paper lighter than 100 g/m<sup>2</sup> may not run as reliably as coated paper heavier than 100 g/m<sup>2</sup>.

### **Recommended baseline/centerline**

---

The following papers are considered to be baseline/centerline and are recommended to ensure you receive the best quality from your stacker:

- Uncoated: Xerox Digital Color Xpressions+, 90 g/m<sup>2</sup>, 24 lbs. In Europe, Xerox Digital Color Colotech+ 90 g/m<sup>2</sup>.
- Coated: Xerox Digital Color Gloss Coated Text (120 g/m<sup>2</sup> /80 lbs.) In Europe, Xerox Digital Color Colotech + Gloss Coated 120 g/m<sup>2</sup>.



## Paper specifications

Paper Size			Output		
Industry Designation	Inches	Orientation	Stacker Tray 60 - 300g/m <sup>2</sup>	Bypass 60 - 300 g/m <sup>2</sup>	Top Tray 60 - 300 g/m <sup>2</sup>
B5	7.2 x 10.1	SEF	Yes	Yes	Yes
B5	7.2 x 10.1	LEF	Yes	Yes	Yes
A4	8.3 x 11.7	SEF	Yes	Yes	Yes
Letter	8.5 x 11	SEF	Yes	Yes	Yes
	8.5 x 13	SEF	Yes	Yes	Yes
Legal	8.5 x 14	SEF	Yes	Yes	Yes
B4	10.1 x 14.3	SEF	Yes	Yes	Yes
	11 x 14.9	SEF	Yes	Yes	Yes
Tabloid	11 x 17	SEF	Yes	Yes	Yes
A3	11.7 x 16.5	SEF	Yes	Yes	Yes
	12 x 18	SEF	Yes	Yes	Yes
SRA3	12.6 x 17.7	SEF	Yes	Yes	Yes
	8 x 10	LEF	Yes	Yes	Yes
A4	8.3 x 11.7	LEF	Yes	Yes	Yes
Letter	8.5 x 11	LEF	Yes	Yes	Yes
Kai8	10.5 x 15.3	SEF	Yes	Yes	Yes
Kai16	10.5 x 7.6	LEF	Yes	Yes	Yes
Transparencies	A4 & Letter	LEF	Yes*	Yes*	Yes*
Labels	A4 & Letter	LEF	No	Yes*	Yes*

\*Customer recommendation is to run stacks of less than 100, but there is no system limit on customer selection.

## Unloading the Stacker Tray

---

Use the following procedure to unload the HCS Stacker Tray when it is full, or you want to retrieve a job that has been completed.



- 1.** Press the **Unload** button on the HCS Control Panel. The Wait light blinks until the HCS Stacker Tray has reached the down position.
- 2.** Open the front door when the Unload Light illuminates.
- 3.** Position the securing bar on top of the stacked paper.
- 4.** Pull the HCS Stacker Cart straight out.
- 5.** Remove the securing bar.
- 6.** Remove the paper from the HCS Stacker Tray.
- 7.** Push the empty Stacker Cart straight into the HCS.
- 8.** Position the securing bar on the fixed area inside the HCS.



**NOTE:** *The front door will not close if the securing bar is not properly attached to the HCS frame.*

- 9.** Close the HCS front door.
- 10.** Follow the instructions displayed on the digital press UI to resume printing.

---

## Selecting Features

---

For jobs coming through the network, refer to the documentation that came with your color server for information on how to select HCS options on the print driver screens.

### How to Enable Automatic Output Switching

---

If your system configuration contains two High Capacity Stackers, you have the option to enable Automatic Output Switching. With Automatic Output Switching, the digital press automatically selects a usable HCS Stacker Tray to deliver your collated sets.

When the HCS Stacker Tray becomes full or when the Unload button is selected, the digital press delivers all paper in the digital press to the same Stacker Tray and then switches to the other Stacker Tray for the rest of the job.



**NOTE:** The HCS Stacker Tray has a capacity of 3500 sheets of 24 lb (90 g/m<sup>2</sup>) centerline paper (or 370mm high). Always refer to the Recommended Materials List and the Speciality Media Guide for up-to-date information on using specific media types with the HCS.

### Using a DFA Finishing Device

---

A DFA (Digital Finishing Architecture) finishing device can be connected directly to the digital press or to the HCS.

All DFA devices are installed by your Xerox service representative. Once installed, the UI screens provide Finishing Module selections.

For jobs coming through the network, refer to the documentation that came with your color server for information on how to select DFA options on the print driver screens.

### Jam clearance

---

A paper jam in the HCS will be indicated by a message on the digital press UI. Follow the instructions displayed. The image on the stacker Control Panel will flash showing the area where the jam is located.

## Clear Bypass area jam

---

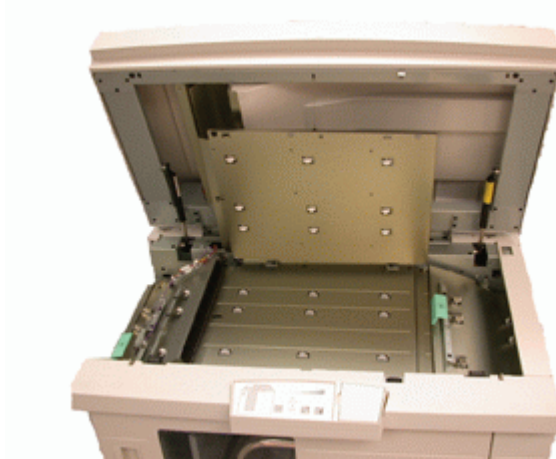

Perform the following steps to clear the HCS jam in the Bypass area and resume printing.

- 1.** Remove any paper from the HCS Top Tray.
- 2.** Lift the HCS **Top Cover**.
- 3.** Lift the green handle, or handles, and remove all paper in the Bypass area. Remove paper only from the areas indicated.
- 4.** Close each green handle.
- 5.** Close the HCS **Top Cover**.
- 6.** If the UI indicates there is a jam in the digital press, follow the instructions on the screen to remove any paper in the area indicates. Additional jam clearance instructions are also provided in Chapter 5 on page 5-5.
- 7.** Follow the instructions displayed on the UI to resume printing.

## Clear Top Tray and Stacker Tray paper jams



To clear the HCS Top Tray, remove all paper from the Top Tray.

Perform the following steps to clear a jam from the HCS Stacker Tray area and resume printing.

1. Press the **Unload** button on the HCS Control Panel. The Wait light blinks until the Stacker Tray has reached the down position.
2. Open the front door when the Unload Light illuminates.
3. Position the securing bar on top of the stacked paper.
4. Pull the HCS Stacker Cart straight out.
5. Reach into the HCS and remove any jammed paper.
6. Push the Stacker Cart straight into the HCS.
7. Position the securing bar on the fixed area inside the HCS.



**NOTE:** *The front door will not close if the securing bar is not properly attached to the HCS frame.*

8. Close the HCS front door.
9. Follow the instructions displayed on the digital press UI to resume printing.

## Maintenance

Do not clean any area inside the HCS unless otherwise instructed by Xerox. If the covers or Front Door require cleaning, dampen a paper towel or soft, clean cloth with a liquid, nonabrasive glass cleaner or water.

To avoid damage to the HCS, do not pour or spray the cleaner or water directly onto the HCS. Always apply the liquid to the cloth first.

Do not use any other cleaners or solvents on the HCS as they may interact with the paint on the covers, eventually causing the paint to peel.

## Problem Solving

If, after following the recommended solutions, the problem persists, call for assistance. The Fault Codes described below appear on the HCS display panel.

Fault Code	Cause	Solution
212 100 212 110 212 120 212 130 212 140 212 900	Paper jam	A jam occurred during feeding. Remove sheets from jam clearance areas. Open and close the top cover and front door. A purge sheet may eject to the top tray. If the jam occurs in the second HCS, be sure to check the Bypass area in the first HCS.
212 251 212 252 212 253 212 254	Stacker problem	Power off, then power on.
212 302	Top Cover open	Close the top cover.
212 540	Stacker tray full	Empty the Stacker Tray.
212 541	Stacker tray position	<ul style="list-style-type: none"> <li>• Press the Unload button. The Wait light blinks until the Stacker Tray has reached the down position.</li> <li>• When the Stacker Tray has reached the down position, open the front door.</li> <li>• Remove the Stacker Cart.</li> <li>• Remove all stacked paper.</li> <li>• Position the Stacker Cart securely into the HCS.</li> <li>• Close the front door.</li> </ul>
212 542	No Stacker Cart	Open the front door. Remove the Stacker Cart from the HCS. Position the Stacker Cart securely into the HCS. Close the front door
212 544	Door open	Close the door

## Loss of Power

---

If power is interrupted to the HCS:

- Ensure the power cord is plugged in to the proper wall receptacle.
- Ensure that the digital press power is on and the Ground Fault Indicator is in the On position.
- If the power has not been restored by the above procedure, call Xerox Customer Support.

Also call your Xerox service representative if the loss of power to the HCS seems to be frequent or excessive.

## Common Stacker/Stapler (CSS)

---

The Common Stacker/Stapler (CSS) is an optional finishing device which provides stacking with offset and single or dual stapling output capabilities. Sets of up to fifty sheets of 64-80 g/m<sup>2</sup> may be stapled.

The CSS must be connected to the right end of the digital press, replacing the Offset Catch Tray. The CSS Stack Tray has a capacity of 2000 sheets of 17-21 lb. (64-80 g/m<sup>2</sup>) paper. The stacker/stapler also has an Offset mode which provides separation between the stacked sets sent to the CSS Stack Tray. The stacker/stapler can also send output (not stapled) of 250 sheets of 17-21 lb. (64-80 g/m<sup>2</sup>) paper to the CSS Top Tray.

Banner sheets can be used with your color server. The banner sheets must be printed on LEF 8.5 x 11 in. paper. Refer to your color server manual for more information on how to turn this feature on.

### Identifying CSS Parts

---

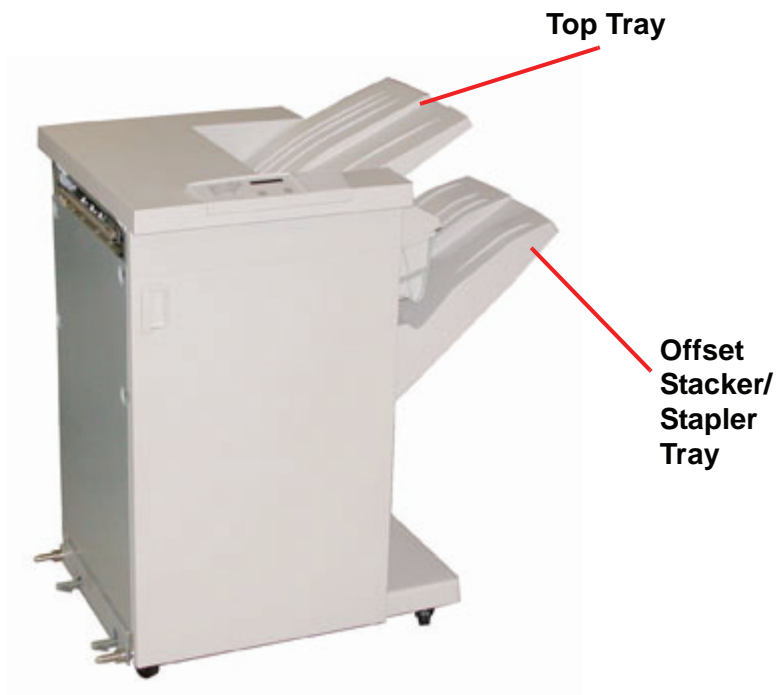



## Control Panel

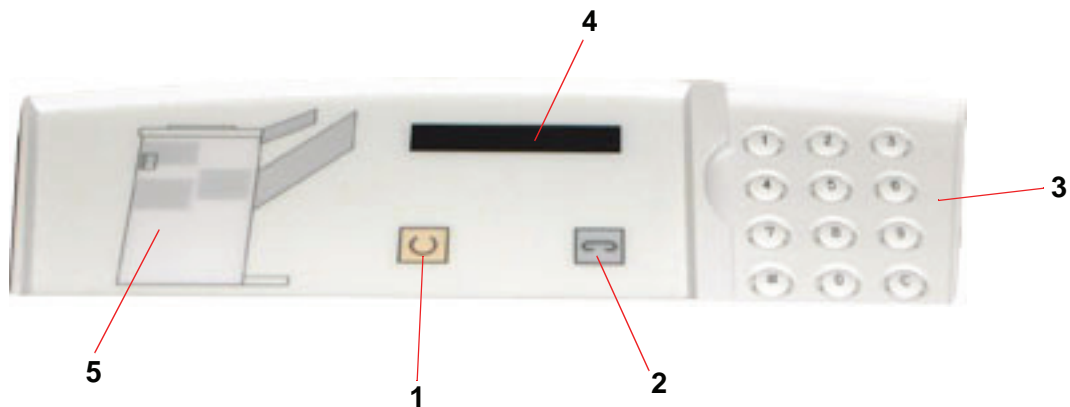

Item Number	Name	Function
1	Ready Indicator	The Ready Indicator blinks when the digital press is being initialized. The Ready Indicator is constant when in use or in standby.
2	Staple Indicator	The Staple Indicator blinks when the staple level in the stapler is low. The Staple Indicator is constant when the stapler is empty.
3	Keypad	The keypad, including the C button, is used only by the Xerox service representative.
4	Message Display	Shows the fault codes.
5	Jam Indicator	Area illuminates to indicate the location of a jam in the CSS and the output location being used.

## Electrical/environmental requirements

**Western Hemisphere:** 115 VAC, 15 amp, for 60 Hz. and 220 VAC, 10 amp for 50 Hz installations.

**Europe:** 200-240 Volt 10 amp 50 Hz service outlet.

The stacker/stapler requires a separate power source from the digital press.

Environmental requirements	Minimum	Maximum
Temperature:	10° C (50° F)	32° C (90° F)
Relative Humidity (% RH):	20%	80%
Altitude:	Not applicable	Anything greater than 2000 meters (6560 ft.) above sea level may require field adjustments



**NOTE:** Best machine performance is achieved when conditions are maintained between 20-25° C (68-77° F).

## Paper stock specifications

The CSS Top Tray accepts all media types, sizes, and weights supported by the digital press. The CSS Stack Tray accepts all standard media sizes supported by the digital press with the including sizes that are larger than A3/11 x 17 in.



**TIP:** Paper that is larger than A3/11 x 17 inch cannot be stapled or offset.

Refer to the following chart for information on accepted media types.

Paper Size				Output		
				CSS Stack Tray 17-59 lb. (60-220 g/m <sup>2</sup> )		CSS Top Tray
Name	Inches	MM	Orientation	Can feed to the Stack Tray? Yes/No	Staple Position (50 sheet maximum for Stapling*)	17-75 lb. (60-300 g/m <sup>2</sup> )
JIS B5	7.2x10.1	182 x 257	SEF	Yes	Portrait	Yes
A4	8.3x11.7	210 x 297	SEF/LEF	Yes	Portrait/ Landscape	Yes
Letter	8.5x11	216 x 279	SEF/LEF	Yes	Portrait/ Landscape	Yes
	8.5x13	216 x 330	SEF	Yes	Portrait/ Landscape	Yes
	8.5x14	216 x 256	SEF	Yes	Portrait/ Landscape	Yes
JIS B4	10.1x14.33	257 x 364	SEF	Yes	Portrait	Yes
	11x17	279 x 432	SEF	Yes	Portrait/Dual	Yes
A3	11.7x16.5	297 x 420	SEF	Yes	Portrait/ Dual	Yes
	12x18	305 x 457	SEF	Yes	Not available	Yes
SRA3	12.6x17.7	320 x 450	SEF	Yes	Not available	Yes
	12.6x19.2	320 x 488	SEF	Yes	Not available	No
B5	7.2x10.1	182 x 257	LEF	Yes	Portrait	Yes
	8x10	203 x 254	LEF	Yes	Portrait	Yes

\* Refer to the table on page 4-24 for information on the stapling capacity for various paper types and weights.



**NOTE:** Transparencies can be fed to both CSS trays.



**TIP:** Paper that is larger than A3/11 x 17 inch cannot be stapled or offset.

## Paper Path

---

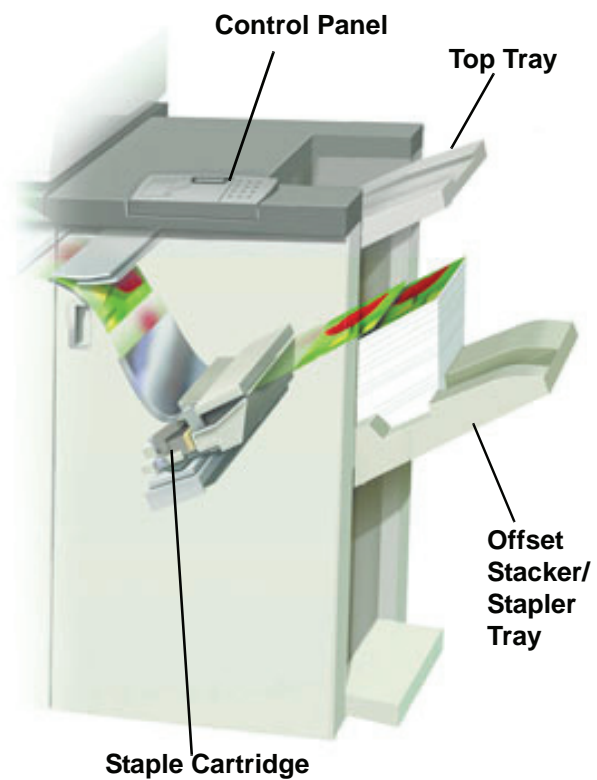

As media enters the CSS, it is fed to the CSS Top Tray or to the CSS Offset Stacker/Stapler Tray, depending on your selections.

---

## Using the stacker/stapler

---

Use the CSS by sending a document through the network and making your selections under Job Properties/Parameters. If you are sending a job through the network, refer to the manuals that came with your color server for information on how to set the job Properties/Parameters when using the CSS.

### Hints and tips

---

- The CSS cannot staple jobs with mixed sizes of paper.
- The stacking may be skewed on the output from mixed size paper jobs.
- You can use mix-coated and uncoated stock.
- The CSS accepts jobs of mixed weight papers below 59 lb. (220 g/m<sup>2</sup>).
- Only clear paper jams at the area indicated on the CSS Control Panel. Do not remove paper from any other areas of the paper path.

### Stapling Hints

---

There are three stapling options:

- **Single Staple Position 1:** The CSS places a staple in the upper left corner of SEF or LEF sets.
- **Single Staple Position 2:** The CSS places a staple in the bottom left corner of SEF sets only.
- **Dual Staple:** The CSS places two staples closer to the top/bottom center of the sheets than a single staple.

All three of these positions are illustrated in the Staple Positions table on page 4-25.

## Paper specifications for stapling

The following chart shows the stapling details for paper size, orientation, destination, and staple position. Numbers have been rounded up or down.

Staple Positions marked with an "O" may be selected in the position indicated. Positions marked with an "X" are not available for stapling. <sup>1</sup> Front Corner = Single Staple Position 1 <sup>2</sup> Rear Corner = Single Staple Position 2			Output Destination	Staple Position (Output fed to Stack Tray)			Output Destination
Inches	MM	Sheet Orientation	Stack Tray 64-220 g/m <sup>2</sup>	Front corner <sup>1</sup>	Rear corner <sup>2</sup>	Dual	Top Tray 64-300 g/m <sup>2</sup> (no stapling)
7.2 x 10.1	JIS B5 (182 x 257)	SEF	Yes	O	X	X	Yes
8.3 x 11.7	A4 (210 x 297)	SEF	Yes	O	O	X	Yes
8.5 x 11	216 x 279	SEF	Yes	O	O	X	Yes
8.5 x 13	216 x 330	SEF	Yes	O	O	X	Yes
8.5 x 14	216 x 356	SEF	Yes	O	O	X	Yes
10.1 x 14.3	JIS B4 (257 x 364)	SEF	Yes	O	X	X	Yes
11 x 17	279 x 432	SEF	Yes	O	X	O	Yes
11.7 x 16.5	A3 (297 x 420)	SEF	Yes	O	X	O	Yes
12 x 18	305 x 457	SEF	Yes	X	X	X	Yes
12.6 x 17.7	320 x 450	SEF	Yes	X	X	X	Yes
12.6 x 19.2	320 x 488	SEF	Yes	X	X	X	Yes
7.2 x 10.1	B5 (182 x 257)	LEF	Yes	O	X	X	Yes
8 x 10	203 x 254	LEF	Yes	O	X	X	Yes
8.3 x 11.7	A4 (210 x 297)	LEF	Yes	O	X	O	Yes
8.5 x 11	216 x 279	LEF	Yes	O	X	O	Yes
10.5 x 15.3	Kai 8 (267 x 388) Asian market size	SEF	Yes	O	X	X	Yes
10.5 x 7.6	Kai 16 (267 x 194) Asian market size	LEF	Yes	O	X	X	Yes











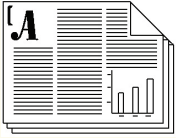
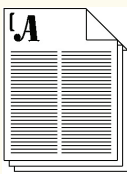



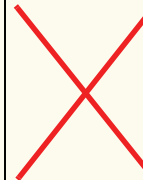

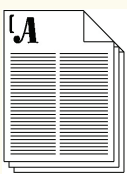



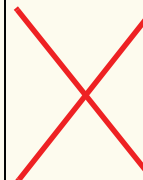

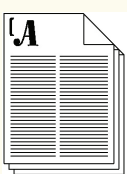



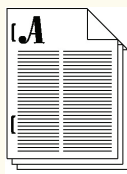
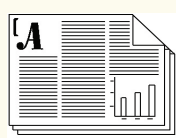

**TIP:** Paper that is larger than A3/11 x 17 inch cannot be stapled or offset.

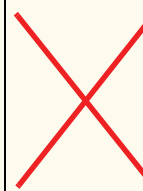

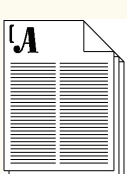



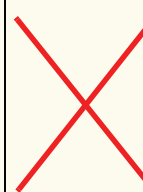

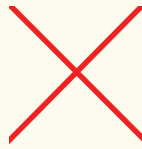
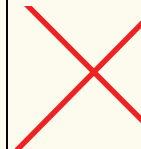
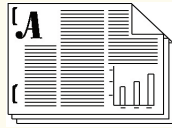

**NOTE:** Stapled sets of large paper (A3, 11 x 17in. and greater) may stack slightly skewed. The stapled sets will be of high quality.

## Staple Positions

Size: Inches (mm)	Staple Position 1 (Front Corner)		Staple Position 2 (Rear Corner)		Dual Staple	
	SEF	LEF	SEF	LEF	SEF	LEF
7.2x10.1 JIS B5 (182x257)						
8x10 (203x254)						
8.5x11 (216x279) A4 8.5x13 (216x330) 8.5x14 (216x356)						
10.1x14.3 JS B4 (257x364) 10.5x15.3 Kai 16 (267x388: Asian market size)						
10.5x7.6 Kai 16 (267x194: Asian market size)						

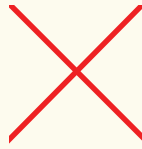
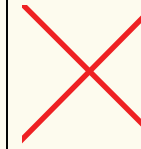
4. Accessories

Size: Inches (mm)	Staple Position 1 (Front Corner)		Staple Position 2 (Rear Corner)		Dual Staple	
	SEF	LEF	SEF	LEF	SEF	LEF
11x17 (279x432)  A3						
12x18 (305x457)  12.6x17.7 (320x450)						



## Stapling capacity for different paper types and weights

Following is the staple capacity for various types and weights of paper.

Paper Weight	Coated	Uncoated	Mix Sizes
64–80 g/m <sup>2</sup>	50	50	No
81–105g/m <sup>2</sup>	42	42	No
106–135 g/m <sup>2</sup>	31	31	No
136–186 g/m <sup>2</sup>	26	26	No
187–220 g/m <sup>2</sup>	18	18	No
221–300 g/m <sup>2</sup>	No *	No *	No
Transparencies	No	No	No

\* 221 to 300 g/m<sup>2</sup> paper, either coated or uncoated, cannot be stapled. These weights will be stacked in the Top Tray.



**TIP:** The Offset Stacker/Stapler Tray may be limited to a maximum of 50 staple sets. In order to avoid system shutdown or jams, ensure that small staple set jobs do not exceed 50 sets. Before you send a stapled-print job to the machine, enable the offset jobs feature; this will improve tray capacity.

## Unloading the stacker/stapler

To ensure consistent quality, unload sets of less than four sheets and lighter weight paper after 50 sets are made, or when the curl of the sets inhibits the ability of the sets to exit the stacker/stapler.

When the Stack Tray is full, Fault Code 112-550 appears in the message display on the stacker/stapler. The digital press UI displays a message, “Unload the Main Tray of the Finisher.”

The stacker/stapler continues to stack sheets into the Stack Tray after the message appears, but excess sheets may have a degraded stacking quality. For best performance, unload the tray when 2,000 sheets have been stacked.

## Jam Clearance

A paper jam in the stacker/stapler is indicated by a message on the digital press UI. The stacker/stapler Control Panel display illuminates the area where the jam has occurred.

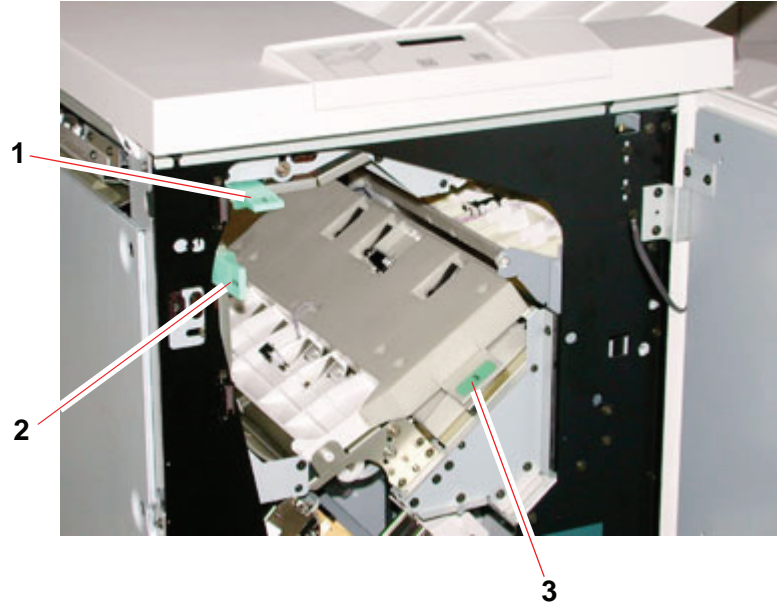

Read the following steps for more information on how to clear a jam.

- 1.** Open the stacker/stapler Front Door. There are three possible jam areas as indicated in the photo above. Handle 1 moves down, Handle 2 moves to the right, and handle 3 moves up.
- 2.** Remove all jammed paper only from the area indicated on the UI and the stacker/stapler Control Panel Display. Do not remove paper from any other areas.
- 3.** Reposition the handle.
- 4.** Close the stacker/stapler Front Door.
- 5.** Follow any instructions on the UI to restart your print job.

## Ordering and Loading Staples

You can order new staple cartridges through the system you normally use for ordering Xerox supplies. The cartridge number to order is 8R12799. You should keep a supply on hand so production is not interrupted while you are waiting for staples to be shipped.

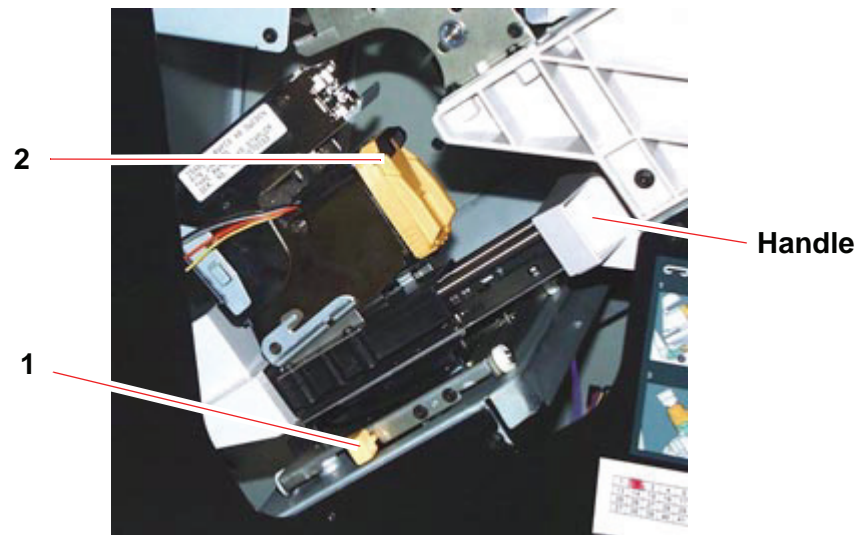

1. Open the front door of the stacker/stapler.
2. Push the Lever 1 down with your left hand. Grasp the handle on the cartridge unit and pull it towards you until it stops. Release the lever and the unit will lock into place.
3. Grasp the staple cartridge (2) and pull it towards you. The entire unit will move forward, then the staple cartridge only will pull free of the unit.
4. Insert a new cartridge into the unit, and push it until you hear it click into place.
5. Push the yellow lever down and the cartridge unit automatically swings back into place.

## Stacker/stapler Maintenance

### Cleaning the stacker/stapler

Do not clean any area inside of the stacker/stapler unless otherwise directed by Xerox. If the stacker/stapler covers require cleaning, dampen a paper towel or soft, clean cloth with a liquid, nonabrasive glass cleaner or water.

To avoid damage to the stacker/stapler, do not pour or spray the cleaner or water directly onto the stacker/stapler. Always apply the liquid to the cloth first.

Do not use any other cleaners or solvents on the stacker/stapler or they may interact with the paint on the covers, eventually causing the paint to peel.

### Problem Solving

If after reviewing the Problems and following the recommended solutions the problem persists, call for assistance.

Problem	Cause	Solution
Fault Code 112-100 Jam indicated in stacker/stapler, but actually is in the Exit Module.	Jammed Paper not visible in stacker/stapler, and fault code does not clear after opening and closing stacker/stapler door.	<ul style="list-style-type: none"> <li>Open the stacker/stapler door.</li> <li>Jammed paper is not visible in the area indicated. Close the stacker/stapler door.</li> <li>The UI indicates a jam in the Exit Module. Open the Exit Module and clear any visible sheets.</li> <li>Open and close the stacker/stapler door.</li> <li>Clear any other areas indicated on the UI.</li> </ul>
Fault Code 112-100 Jam indicated in stacker/stapler. No visible jams in stacker/stapler because sheet is located over the Exit Module sensor.	Paper jammed between Exit Module and stacker/stapler sensors	<ul style="list-style-type: none"> <li>Open the stacker/stapler door.</li> <li>Jammed paper is not visible in the area indicated. Close the stacker/stapler door.</li> <li>If the fault code remains, open the Exit Module. No jammed sheets are visible.</li> <li>Undock the stacker/stapler. Find the jammed sheet between the Exit Module and the stacker/stapler. Refer to the Note below this table for information on how to undock the stacker/stapler.</li> <li>Clear any other areas indicated on the UI.</li> </ul>

Problem	Cause	Solution
Fault Code 112-130 Jam indicated in stacker/stapler, but is also in Exit Module.	Paper is jammed over both the Exit Module and stacker/stapler sensors.	<ul style="list-style-type: none"> <li>• Open the stacker/stapler door.</li> <li>• Clear any visible jams.</li> <li>• If no jammed paper is visible in the stacker/stapler area indicated, open the Exit Module door and clear any jammed paper. Close the Exit Module door.</li> <li>• Open and close the stacker/stapler door.</li> </ul>
Fault Code 112-130 Jam indicated in stacker/stapler.	Paper is jammed between the Exit Module and the stacker/stapler sensors.	<ul style="list-style-type: none"> <li>• Open the stacker/stapler door.</li> <li>• If no jammed paper is visible in the area indicated, open the Exit Module door and clear any jammed paper. Close the Exit Module door.</li> <li>• Open and close the stacker/stapler door.</li> <li>• If the fault persists, undock the stacker/stapler and clear the jammed paper between the Exit Module and the stacker/stapler. Refer to the Note below this table for information on how to undock the stacker/stapler.</li> </ul>
Fault Code 112-110	Paper jammed in the stacker/stapler and the Exit Module during a purge of sheets to the Top Tray.	<ul style="list-style-type: none"> <li>• Clear the jammed paper from the stacker/stapler.</li> <li>• Clear the jammed paper from the Exit Module.</li> <li>• Open and close the stacker/stapler door.</li> <li>• Resume job.</li> </ul>
Fault Code 052-310	Communication problem	<ul style="list-style-type: none"> <li>• Cancel or save the job.</li> <li>• Power off the digital press. Wait 15 seconds and power on.</li> </ul>
Fault Code 052-321	Connection problem	<ul style="list-style-type: none"> <li>• Cancel or save the job.</li> <li>• Power off the digital press. Wait 15 seconds and power on.</li> </ul>
Fault Code 052-320	Unexpected connection	<ul style="list-style-type: none"> <li>• Cancel or save the job.</li> <li>• Power off the digital press. Wait 15 seconds and power on.</li> </ul>
Fault Code 052-312	Communication problem	<ul style="list-style-type: none"> <li>• Cancel or save the job.</li> <li>• Power off the digital press. Wait 15 seconds and power on.</li> </ul>
Ready Indicator does not illuminate	No power	<ul style="list-style-type: none"> <li>• Check the power cord connected to the power source.</li> <li>• Check that the main switch is on.</li> </ul>

Problem	Cause	Solution
Poor Stacking:	Mixed sizes of paper	Run separate jobs and empty stacker.
	High paper curl	<ul style="list-style-type: none"> <li>Adjust digital press Decurler. See, “<a href="#">Decurler Profile</a>” on page 2-5 for additional information.</li> <li>Flip paper in digital press paper tray(s).</li> <li>Rotate paper in the digital press paper tray(s).</li> </ul>
	Mechanical obstruction	<ul style="list-style-type: none"> <li>Check for obstruction in the stacker stapler paper path.</li> <li>Ensure that all transports and baffles are properly seated.</li> </ul>
Paper Jams:	Use Top Tray	Deselect offset or restart job to the Top Tray.
	High paper curl	<ul style="list-style-type: none"> <li>Adjust digital press Decurler. See, “<a href="#">Decurler Profile</a>” on page 2-5 for additional information.</li> <li>Flip paper in digital press paper tray(s).</li> <li>Rotate paper in the digital press paper tray(s).</li> <li>Switch to heavier paper.</li> </ul>



**NOTE:** To undock the stacker/stapler from the digital press, reach into the circular area near the bottom of the stacker/stapler for the Undocking Lever. Refer to the picture below.



**Location of Undocking Lever**

Pull the lever toward you and hold it in position while moving the stacker/stapler a small distance (25.4mm, 1in.) away from the press. Release the lever and continue to move the stacker/stapler as far as required.

## Loss of Power

---

If power is interrupted to the stacker/stapler:

- Ensure the power cord is plugged in to the proper wall receptacle.
- Ensure that the digital press power is on.
- If the power has not been restored by the above procedure, call Xerox Customer Support.

Also call your Xerox service representative if the loss of power to the stacker/stapler seems to be frequent or excessive.





---

## 5. Problem solving

When a problem occurs with your digital press, instructions appear on the UI. Refer to the information in this chapter to help resolve the problem.

### General problems

---

If the digital press has a loss of power and you cannot access the Machine Details screen to get the serial number, open the two main front doors. The serial number label is in the center of the bottom frame of the digital press.

The charts on the following pages list problems and suggested solutions that apply to your digital press. If the problem persists after following all instructions, call your Xerox representative.



**NOTE:** *If your color server indicates that the digital press has a fault and the UI does not readily display a message, select **Machine Details** from the System pull-down menu, then select the Error Log tab to display the fault history.*

Problem	Suggested solutions
The digital press does not power on.	<ul style="list-style-type: none"> <li>• Ensure the power cord is plugged into the receptacle correctly.</li> <li>• Ensure the power switch inside the front door is set to the ON position.</li> <li>• Check the GFI circuit breakers.</li> <li>• If the power in your location is working properly, you have tried the suggested solutions, and the digital press does not power on, call for assistance.</li> </ul>
Prints are not on desired paper size.	<ul style="list-style-type: none"> <li>• Ensure that the proper paper is loaded in the paper trays.</li> <li>• Select the paper size, tray and weight through the digital press options on your PC.</li> <li>• Ensure that the correct weight is set on the Tray Properties window.</li> <li>• Ensure that “Fit to Paper” or an equivalent selection is not selected in your print driver.</li> </ul>
Paper is misfed or wrinkles repeatedly.	<ul style="list-style-type: none"> <li>• If a message appears on the UI, follow the instructions displayed.</li> <li>• Ensure the proper paper is loaded correctly and not filled above the MAX line. Refer to <i>The Recommended Materials List</i>.</li> <li>• Turn the paper stack around and/or over in the selected paper tray.</li> <li>• Remove a few sheets from the top and the bottom of the stack in the paper tray.</li> <li>• Fan all four edges of the paper in the selected paper tray.</li> <li>• Replace the paper in the selected paper tray with paper from a new package.</li> <li>• Remove any partially fed paper from the trays.</li> <li>• Ensure the paper you are using had been stored properly.</li> </ul>

Problem	Suggested Solution
The UI does not respond to a command.	<ul style="list-style-type: none"><li>• Select <b>Restart User Interface</b> from the <b>System</b> pull-down menu on the UI.</li><li>• Select <b>Shutdown System PC</b> from the <b>System</b> pull-down menu. After the System PC shuts down, wait 15 seconds and restart it by pressing the on/off button on the PC.</li><li>• If the problem persists, call for service.</li></ul>
Transparencies are too oily.	<ul style="list-style-type: none"><li>• Make 5 blank sheet copies with the Full Color option on paper stock to purge excess oil from system. Reload the transparencies and continue the copying job.</li><li>• Refer to the <i>Recommended Materials List</i> and the <i>Color Materials Usage Guide</i> for more information about transparencies.</li></ul>
Multiple sheets feed from the paper trays.	<ul style="list-style-type: none"><li>• Do not fill the paper trays above the MAX fill line indicator.</li><li>• Remove the paper from the tray and fan the sheets to separate the joined sheets.</li><li>• Predrilled sheets may stick together at the holes. Remove the paper from the tray and fan the sheets to separate the joined sheets.</li><li>• Paper and transparencies may stick together if environmental conditions are too dry and cause excessive static. Increase the humidity level in the room to minimize static.</li><li>• Gently fan transparencies to separate the sheets before you load them.</li></ul>

Problem	Suggested Solution
Paper jams when exiting the Paper Trays	<ul style="list-style-type: none"> <li>• Ensure that the edge guides of the paper tray fit snugly against the paper stack.</li> <li>• Do not fill the paper trays above the MAX fill line indicator.</li> <li>• Close the tray slowly to avoid shifting the paper stack.</li> </ul>
Output jams when exiting the digital press to the Offset Catch Tray	<ul style="list-style-type: none"> <li>• When no other output device is present, the Offset Catch Tray can hold up to 500 sheets of 24 pound (90 g/m<sup>2</sup>) paper. Empty the catch tray when output approaches this limit to ensure continuous production.</li> <li>• Ensure the first sheet is not blocking the paper exit, particularly for 11 x 17 inch (A3) output.</li> </ul>
Excessive paper curl	<p>Paper curl may be a result of:</p> <ul style="list-style-type: none"> <li>• Ensure that the correct paper weight and paper type are selected.</li> <li>• The mass of dry ink (toner) coverage on the print output - the greater the toner mass, the greater the paper curl.</li> <li>• The paper weight.</li> <li>• The humidity conditions at the digital press.</li> <li>• You can sometimes minimize curl problems by flipping the paper over in the tray and making the copies again. If excessive curl is still present, use a heavier paper.</li> <li>• Empty the output device when output approaches this limit to ensure continuous production.</li> </ul> <p>Paper curl may be a result of an attempt to print on thicker paper or on paper stock that is less sensitive to moisture.</p> <p><b>Note:</b> If you have a problem with curl, you may want to use the Decurler adjustment options. Decurler Profile settings Default and A-D are available to the user. See, Chapter 2 Tray Properties for additional details. For additional information on the Decurler and the step-by-step instructions on using it, Chapter 3 of the Administrator Guide, which is located on your Customer Documentation CD, or at <a href="http://www.xerox.com">www.xerox.com</a>.</p>
It is difficult to perform secondary operations on the output prints, such as writing on them or using adhesives.	<p>This problem is caused by the oil used in the fusing process. The problem can be reduced or eliminated by setting the prints aside for one or two hours before performing a secondary operation on them. Rubbing the print surface with a soft, clean cloth or eraser may also help.</p>

## Jam clearance

If a jam occurs, the digital press stops printing and a message is displayed on the UI. Follow all instructions displayed completely and in sequence, and follow the instructions provided here for further assistance in clearing the jam.

If power is interrupted during the printing process, it is imperative that you clear all other jam areas before you open and clear areas behind the Right and Left Front Doors of the digital press. The following illustration shows the various parts of the digital press. Follow the jam clearance instructions on the UI.

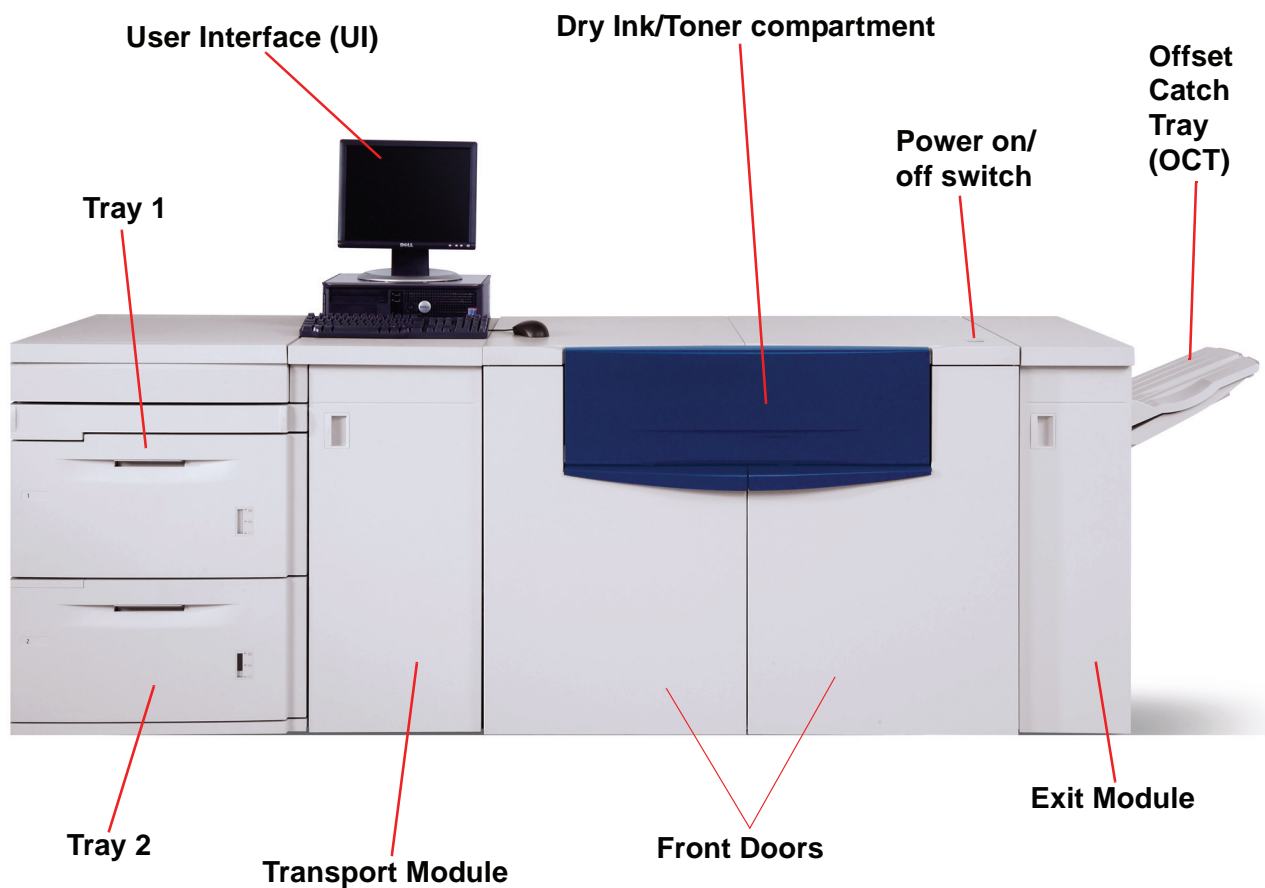

## Paper tray jams



**CAUTION:** Be careful of the Feed Heads and the Feed Rolls. They can be damaged with rough treatment.

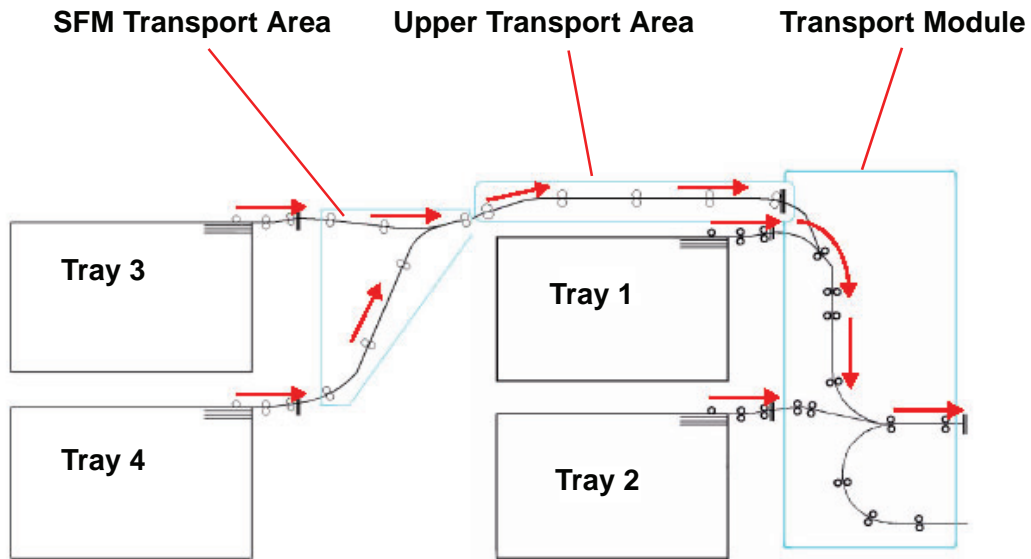

The UI displays an animation showing the tray containing the jam.



**1.** Open the tray with the jam.



**CAUTION:** If you hear paper tearing, stop opening the tray. Open the door of the Transport Module or the SFM Transport Area and clear the paper from the Transport Module before attempting to open the tray again.

**2.** Carefully remove all jammed paper.

**3.** Use the UI to determine if further jams exist and clear those areas.

## Upper Transport Area jam



**TIP:** Jams occur in this area *only* when the Second Feeder Module containing Trays 3 and 4 is connected.

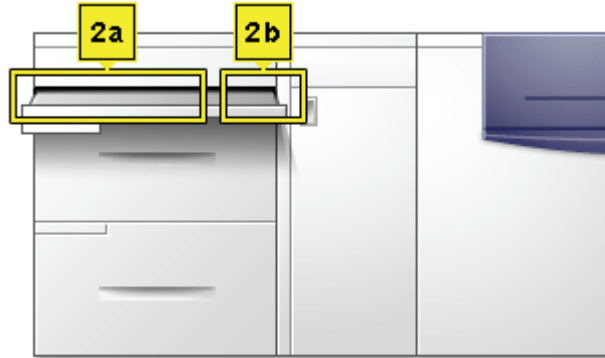

1. Pull out the Transport Area Drawer above Tray 1.
2. Lift up the handle.
3. Remove all jammed paper.
4. Return the drawer to its original position.
5. Follow the instructions on the UI to clear other areas or to resume your print job.

## Transport Module jams

Open the areas in the Transport Module indicated on the UI. Carefully remove all jammed paper.



1. Open the Transport Module door.
2. Grasp the green handles 3a, squeeze and move it to the right.
3. Carefully remove all jammed paper.
4. Reposition handles 3a.
5. Lift up green handles 3b.
6. Carefully remove all jammed paper and return handles 3b to their original position.
7. Follow the UI messages and, if required, lift handles 7a and remove all jammed paper.
8. Return handles 7a to their original position.
9. Squeeze handles 7b and lower to the right. Remove all jammed paper.
10. Return handles 7b to their original position.
11. Squeeze handles 7c and lower to the left. Remove all jammed paper.
12. Return handles 7c to their original position.
13. Close the Transport Module door.
14. Follow the instructions on the UI to restart your print job.



## Exit Module jams

Follow the instructions on the UI to clear jams from all the areas indicated in the Exit Module. The following picture shows the areas where jams could be located.

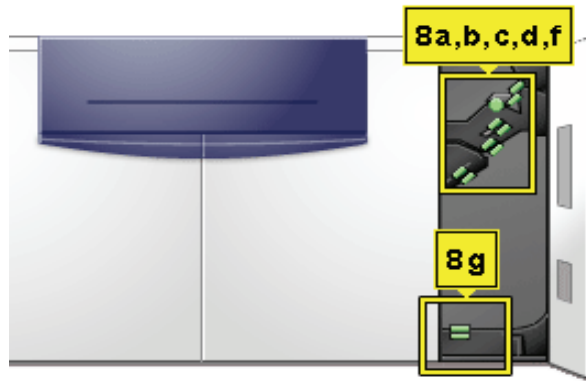

Follow the instructions on the UI to restart your print job.

## Right/left door paper path jams

Always follow the instructions on the UI to locate and clear jams.



**TIP:** It is imperative that you clear all other jam areas before you open and clear the Right and Left Front Door areas.

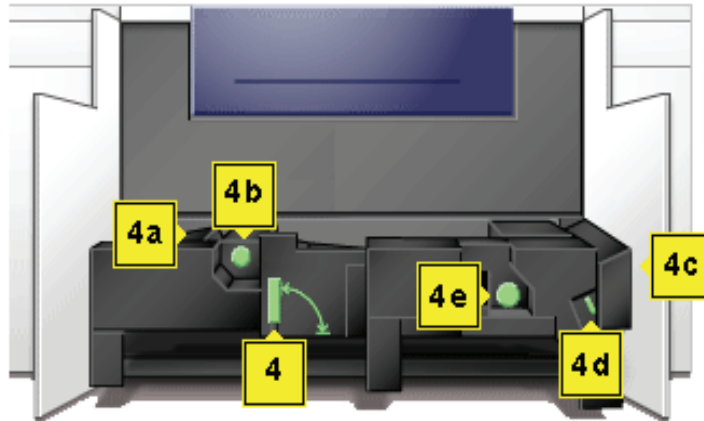

**CAUTION:** Be careful when clearing jams in the Fuser area, The Fuser is extremely hot and will cause injury.



**1.** Open the Right and Left Front Doors when directed to by a UI message.

**2.** Grasp handle 4 and move it in the direction of the arrow.

**3.** Slowly pull out the Paper Transport module until it stops.

**4.** Lift handle 4a and carefully remove all jammed paper, ensuring that all pieces are removed if the paper is torn.

**5.** Turn the green handle 4b to free any paper that is caught.

**6.** Reposition green handle 4a.



**CAUTION:** Be careful when clearing jams in the Fuser area, The Fuser is extremely hot and will cause injury.

**7.** The Fuser area is on the right hand side of the Paper Transport module. Lift handle 4c on the right hand side and pull to open.

**8.** Lift up handle 4d until it stops and clear any jammed paper. Rotate knob 4e in the direction of the arrow on the knob to clear any paper that is caught.



**NOTE:** Occasionally a sheet of paper wraps around the heat roll. (The heat roll is visible when handle 4d is up). DO NOT attempt to remove this sheet of paper because the stripper fingers may be damaged if you attempt this procedure. Call your Xerox service representative to remove this piece of paper.

- 9.** Reposition green handle 4d and close area 4c. Ensure these are firmly in place.
- 10.** Grasp handle 4 and slowly push in the Paper Transport until it stops. Turn the handle in the direction of the arrow to lock the module in place.
- 11.** Close the Right and Left Front Doors.
- 12.** Follow the instructions on the UI to restart your print job.

### Jam clearance with 2-sided printing

When printing 2-Sided output, the UI will direct you to clear the following areas if a jam occurs.

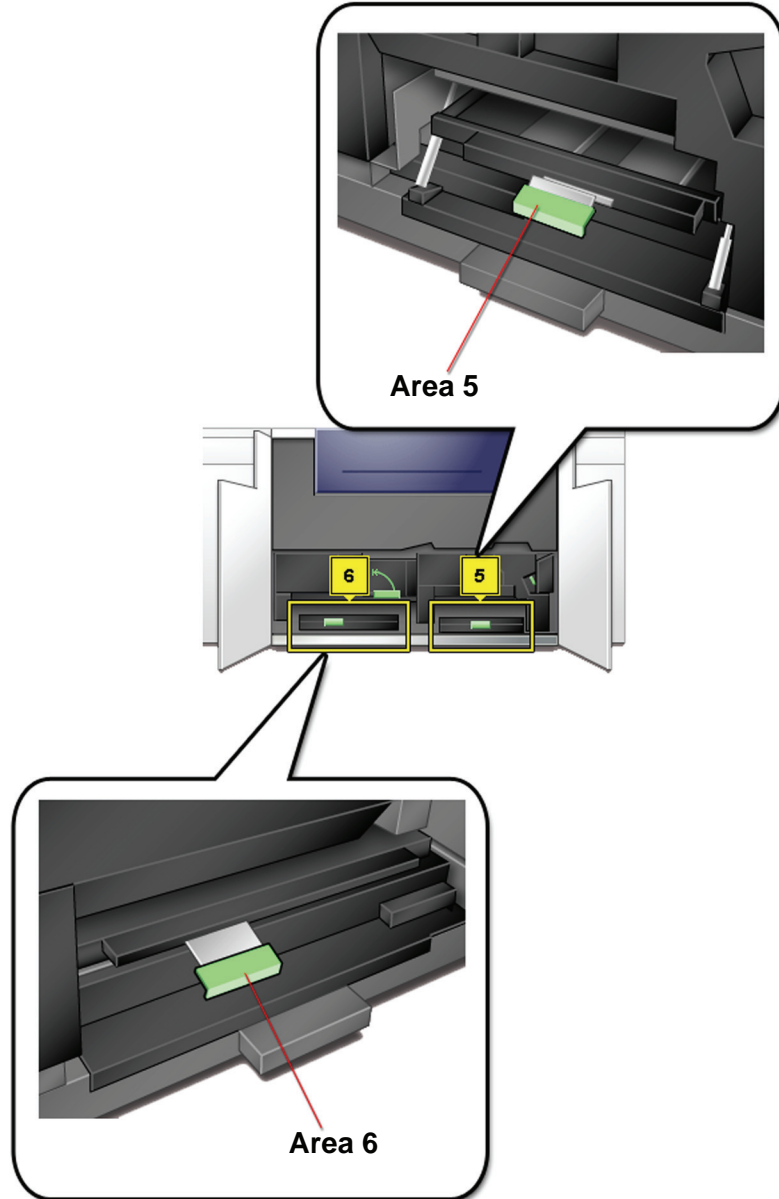

1. Open the Right and Left Front Doors when directed to by a UI message.
  2. Lift handle 5 and clear any paper in the area.
- CAUTION:** Paper can rip if not pushed back before removing it from under the lip of this area.
3. Push the paper back until you see the front edge, then remove the paper.

4. Reposition handle 5 by closing firmly.
5. Lift handle 6 and clear any paper in the area.
6. Push the paper back until you see the front edge, then remove the paper.
7. Reposition handle 6 by closing firmly.
8. Close the Right and Left Front Doors.
9. Follow the instructions on the UI to restart your print job.

## Fault Codes

When there is a problem with the digital press or an accessory, refer to the UI where the Fault Code and a solution will be displayed. Follow all steps until the problem is corrected. If the problem persists, call one of the following numbers for assistance.

Follow the instructions below before calling for service.



1. Be prepared to provide a complete description of the problem to the service operator. Defining the problem accurately may help you and the operator solve the problem over the phone and minimize downtime. If the problem cannot be solved by telephone, a service representative will be dispatched to your site promptly.
2. Record the displayed Fault Codes.
3. Record the Machine Serial Number by selecting **Machine Status** from the **System** pull-down menu on the UI. (If the serial number is not displayed, open the Right/Left Front Doors of the digital press. The serial number is also on a white label on the bottom front frame.)
4. If copy quality is a problem, take a copy sample to the telephone with you to help you describe the problem or to assist you when answering the questions from the service operator about the defects.
5. If possible, use a phone near the press when calling for assistance. Follow the instructions provided by the operator.

- 6.** For system support, user help, and service support, call the appropriate number:

US:**1-800-821-2797** (Includes TTY support)

Canada:**1-800-939-3769**

Europe: \_\_\_\_\_

Latin America: \_\_\_\_\_

Xerox also provides web-based customer support. Go to:

[www.xerox.com/eSupportCentre](http://www.xerox.com/eSupportCentre)

---

## 6. Technical Data

### Digital Press Specifications

---

#### Electrical Power

---

##### Specifications

---

200-240V - 50/60 Hz

Single phase - Three wires plus safety ground

Current service - 30 Amp sole use @ 200V to 240V

Range (line to neutral) - 200 V minimum to 240 V maximum

Frequency - 50/60 Hz

##### Power Consumption

---

Standby - 3.0 kW

Run - 6 kW

Power Saver - 45W

##### Warm-up Time

---

Within 7 minutes from power on or from Power Saver Mode.

##### First Print Out Time

---

16 seconds maximum.

##### Reliability

---

Average monthly print volume (AMPV) is 70,000 for 8.5 x 11/A4 prints

## Environmental Requirements

---

The digital press will enter the Power Saver mode after 15 minutes of no activity on the machine.

The factory default time of 15 minutes can be changed when logged on as the Administrator. For more information, refer to the Administrator Guide.

## Ambient Temperature and Humidity

---

10 to 32°C, 15 to 85% Relative Humidity (RH)

50 to 90°F, 15 to 85% RH



**NOTE:** Above 82°F (28°C), reduced humidity is required to maintain the specified performance. It is not recommended to use coated stock if the RH is above 60%.

## Altitude

---

Normal operation: 0 to 2,000 meters (0 to 6,500 feet).

Operation between 2,000 to 2,500 meters (6,557 to 8,200 feet) may require a field adjustment.

## Illumination

---

Normal function (free from print quality defects) can be expected under 3,000 lx maximum.

## Noise Levels

---

	Continuous Noise	Impulse Noise
Standby	53.7 dB	N/A
Digital Press Operation	73.5 dB	75 dB
Full System Operation	75.2 dB	79.4 dB

## Ozone Emissions

---

Not to exceed 0.015 mg/m<sup>3</sup> (as per Product Safety Standards Addendum C11-BP-705)



## Dust

---

0.4mg/m<sup>3</sup> or less per Environment Product Safety Manual, PS-22B008

## Capabilities

---

### Tray Capacity

---

All paper trays (First and Second Feeder modules) have a capacity of 2000 sheets each of 24 lb./90 g/m<sup>2</sup>, uncoated paper or 80 lb./120 g/m<sup>2</sup>, coated paper.

### Throughput

---

All paper trays:

**Type:** Coated or uncoated paper, transparencies

**Sizes:** Minimum = 182mm x 182mm (7.2 x 7.2")

Maximum = 320mm W, 488mm L (12.6 x 19.2")

**Weights:** 60g/m<sup>2</sup> to 300g/m<sup>2</sup> (16 lb bond to 110 lb cover)

**Size/Loading Orientation:**

B5 SEF/LEF

A4 SEF/LEF

B4 SEF

A3 SEF

8 x 10" LEF/SEF

8.5 x 11" SEF/LEF

8.5 x 13" SEF

8.5 x 14" SEF

11 x 17" SEF

12 x 18" SEF

12.6 x 17.7 SEF

SRA3 (320 mm x 450 mm) SEF

### Output Tray Capacity

- Offset Catch Tray (OCT):** (This is the standard output device) 500 sheets
- Optional High Capacity Stacker (HCS):** 3500 sheets in stack tray; 250 sheets in top tray
- Optional Common Stacker Stapler (CSS):** 2,000 sheets (60-220 g/m<sup>2</sup>); 250 sheets in top tray (60-300 g/m<sup>2</sup>)

### Print Rates

Use the Productivity Setting to optimize the throughput speed for the weight of the paper you are using.

- Selecting **All Weights Rated Speed** runs all jobs at the same speed regardless of the paper weight. Gloss levels may appear lower on heavier weight media.
- Selecting **Mixed Paper Weight** sets the Fuser temperature to 175°C, which optimizes the throughput speed for mixed paper weights from different paper trays, and uses more power.

Refer to the Administrator Guide to change the setting.

The following chart illustrates the print speeds for the two modes using 8.5x11" or A4 paper fed LEF.

DocuColor 5000AP Digital Press				
Paper Weight	Mixed Paper Weight Mode		All Weights Rated Speed	
	1 Sided	2 Sided	1 Sided	2 Sided
60 - 80 g/m <sup>2</sup>	50 ppm*	25 ppm	50 ppm	25 ppm
81 - 105 g/m <sup>2</sup>	50 ppm	25 ppm	50 ppm	25 ppm
106 - 135 g/m <sup>2</sup>	50 ppm	25 ppm	50 ppm	25 ppm
136 - 186 g/m <sup>2</sup>	33.3 ppm	16.7 ppm	50 ppm	25 ppm
187 - 220 g/m <sup>2</sup>	33.3 ppm	16.7 ppm	50 ppm	25 ppm
221 - 300 g/m <sup>2</sup>	25 ppm	-----	50 ppm	25 ppm
Transparencies	25 ppm	-----	-----	-----

\*ppm = prints per minute

The Average Monthly Print Volume (AMPV) is 70,000 for 8.5 x 11 in/A4 standard paper.

## Physical Characteristics

---

### Digital Press Size

---

Basic configuration of First Feeder Module, Digital Press with Exit Module, and Offset Catch Tray is 115 inches/2920 mm (W) x 29.8 inches/757 mm (D) x 38.2 inches /970 mm (H)\*.

\*(57.5 inches/1461 mm (H) includes the System PC)

### Digital Press Weight

---

1654 pounds/750 Kg max

### Floor Space Requirements

---

Minimum space requirements for the basic configuration of the digital press, not including a color server:

158.3 inches/4020mm W x 121.4 inches/3083mm D.

## Metric Conversion Chart

Inches	Millimeters (mm)	Inches	Millimeters (mm)	Inches/ International Sizes	Millimeters (mm)	Celsius (°C)	Fahrenheit (°F)
0.01	0.254	6	153	13.5	343	10	50
0.04	1	7.2	183	14.0	356	32	90
0.05	1	7.3	185	8.0	203	100	212
0.1	3	7.5	190	15.75	400	200	392
0.15	4	7.8	198	16.9	429	204	400
0.2	5	8.0	203	17.0	432	218	425
0.25	6	8.3	211	24.0	610		
0.28	7	8.4	213				
0.3	7	8.5	216				
0.5	13	8.7	221	5 x 8	127 x 203		
0.6	15	9.0	229	8 x 10	203 x 254		
0.7	18	10.0	254	8 x 11	203 x 279		
0.8	20	10.5	267	A4	210 x 297		
1	25.4	10.8	274	8.5 x 11	216 x 279	<b>Kilo-grams</b>	<b>Pounds</b>
1.4	36	11.0	279	8.5 x 13	216 x 330	1.0	2.205
1.5	38	11.1	282	8.5 x 14	216 x 356	0.454	1.0
1.7	43	11.15	283	8.7 x 14	221 x 356		
1.9	48	11.5	292	9 x 11	229 x 279		
2	51	11.8	300	9 x 14	229 x 356		
2.3	58	11.85	301	11 x 17	279 x 432		
2.5	64	12.5	318	A3	297 x 420		
3	76	13.0	330	12 x 17	305 x 432		
4	104	13.4	340	12 x 18	305 x 457		
5	127	13.45	342	SRA3 12.6 x 17.7	320 x 450		

---

## 7. Maintenance

This chapter describes the procedures necessary for maintaining optimal operating reliability for your machine.

For troubleshooting problems, refer to “Problem solving” on page 5-1. Unresolved problems need to be referred to your Xerox service representative. Use the procedure in this section when it becomes necessary to request a service call.

The procedure for ordering supplies and a list of the supplies you should keep on-hand are also included in this chapter.

---

### Cleaning procedures

---

#### Cleaning the digital press

If the exterior surfaces require cleaning, dampen a paper towel or a soft, clean cloth with a liquid, nonabrasive glass cleaner or water.



**WARNING:** Do not use any other cleaners or solvents on the digital press as they may interact with the paint on the covers, eventually causing the paint to peel.



**WARNING:** DO NOT pour or spray liquid directly into any of the paper trays. Always apply the liquid to the cloth first.

---

#### Cleaning the UI screen

Clean the UI screen at the start of each day. Remove all dust and fingerprints by wiping the screen with a clean, lint-free cloth.



**CAUTION:** To avoid damage, do not use any Xerox cleaner, water, or commercial cleaner on the screen.

## Cleaning the Second Transport and Fusing areas

Use the following procedure if your output prints have dirt or contamination on them, or if you receive multiple paper jams in Area 4.



**NOTE:** It is recommended that you perform this procedure one time per day, preferably at the start of the day before the digital press is switched on and the fuser is hot.



**WARNING:** If the digital press is switched on and the fuser is hot, be sure to switch off the digital press power and allow 15 minutes for the fuser to cool before performing this procedure.



1. Open the front doors.

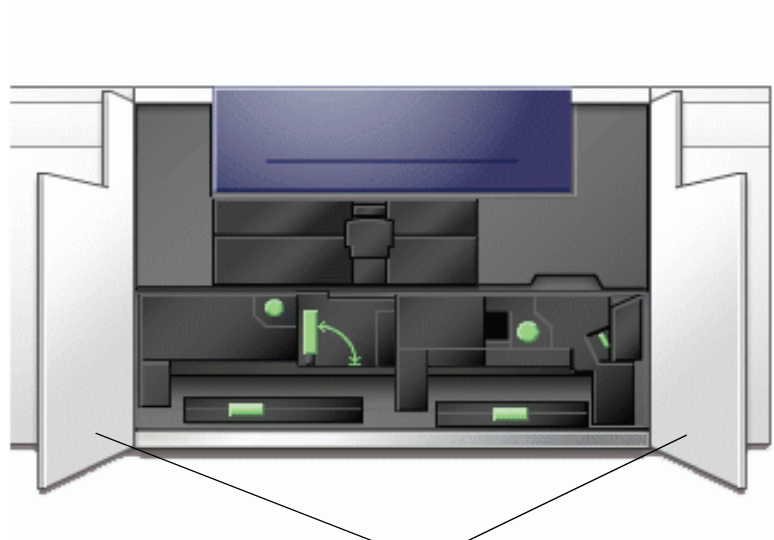

Front Doors

2. Grasp handle 4 and move it in the direction of the arrow.

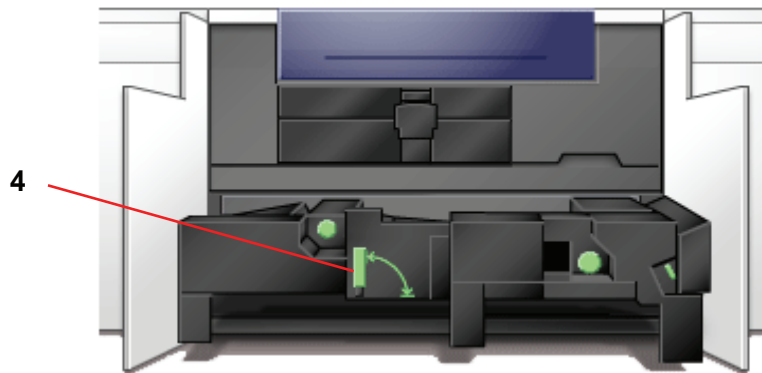

3. Slowly pull out the Paper Transport module until it stops.
4. Clean the chute area as outlined in yellow in the illustration below by wiping it with lint-free cloth:

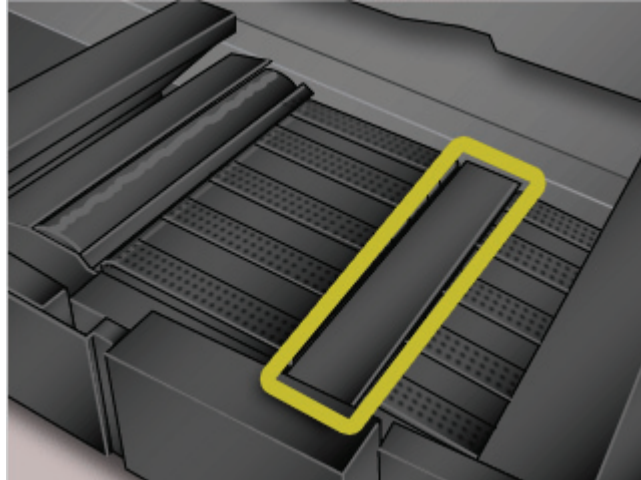

**NOTE:** It is recommended that you use the lint-free cloth supplied with your digital press, Xerox part number 19K03610.



**TIP:** Avoid touching the chute area with your bare hands as this will leave grease and dirt on that area and create paper jams.

5. Clean the belts, outlined in yellow:

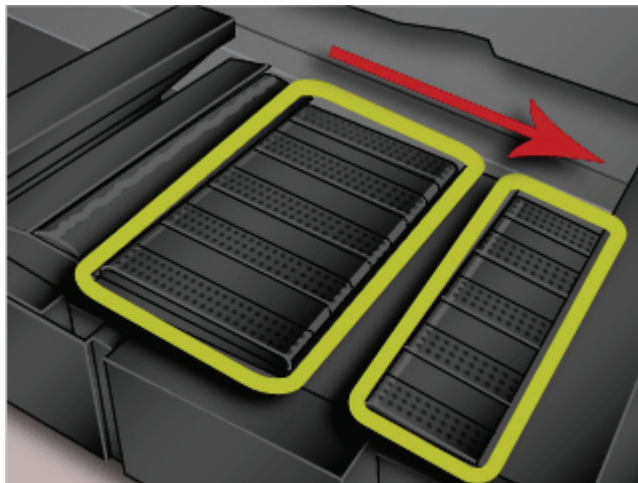

**NOTE:** It is recommended that you use the lint-free cloth supplied with your digital press, Xerox part number 19K03610.

- Use a lint-free cloth to wipe the belts
- Using the lint-free cloth, rotate the belts in the direction that paper travels; refer to the arrow in the above illustration. Continue to wipe the belts as you rotate them.



**NOTE:** Do not rotate the belts with your bare hands as this will leave grease and dirt on them and create paper jams. Rotate the belts by using a lint-free cloth.

- Continue to rotate and wipe the belts until all the belts are clean.

- 6.** Clean the areas between each belt by wiping them with a lint-free cloth.



**NOTE:** It is recommended that you use the lint-free cloth supplied with your digital press, Xerox part number 19K03610.

- 7.** Clean the sensors (circled below) with a lint-free cloth.

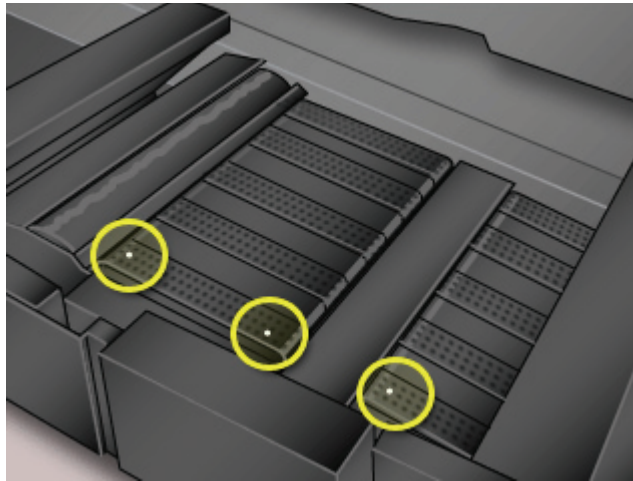

- 8.** Grasp handle 4 and slowly push in the Paper Transport until it stops. Turn the handle in the direction of the arrow to lock the module in place.

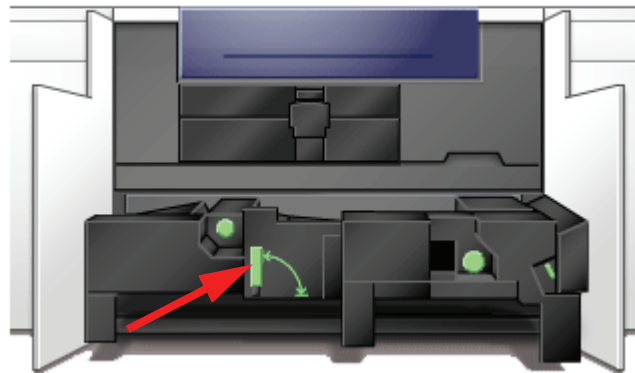



9. Close the right and left front doors.

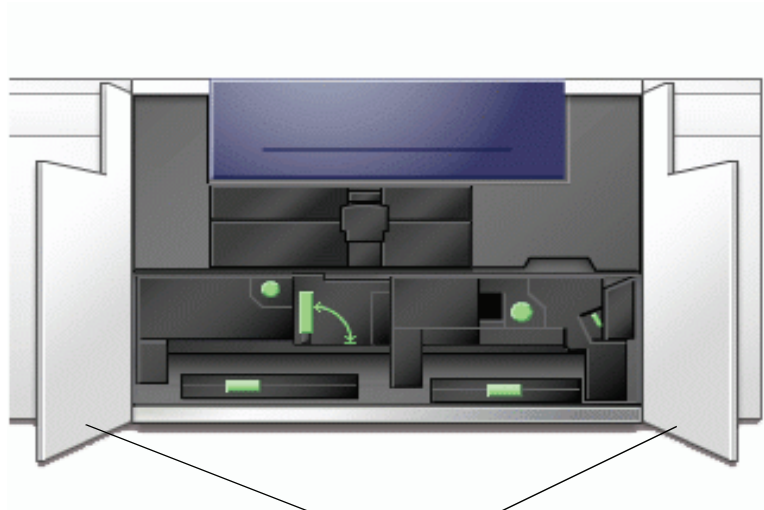

Front Doors

10. Switch on the digital press power.

## Cleaning the paper path

Use the following procedure to clean excessive paper dust/fibers from the paper path area.



**NOTE:** It is recommended that you perform this procedure one time per day, preferably at the start of the day before the digital press is switched on and the fuser is hot.



**WARNING:** If the digital press is switched on and the fuser is hot, be sure to switch off the digital press power and allow 15 minutes for the fuser to cool before performing this procedure.



**CAUTION:** Only clean the recommended areas of the paper path as described in this procedure.

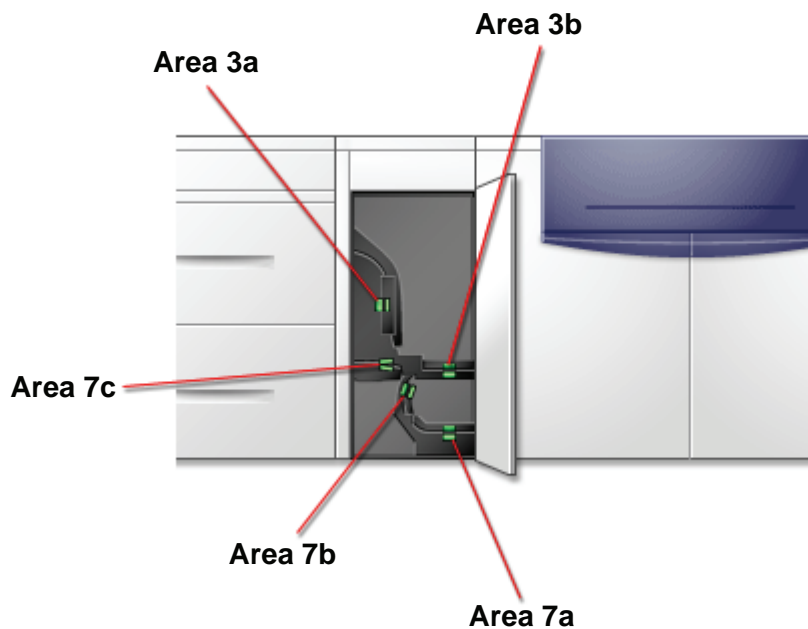

1. Use a damp, water moistened (not wet), lint-free cloth to clean the paper path only in the green handle jam clearance areas as shown in the illustration.
  - a. Open each area and clean both surfaces of the transports.
  - b. Remove any residual moisture with a dry, lint-free cloth.



**NOTE:** Only perform the following step if your machine has an optional SFM attached. If your machine does not have an optional SFM attached, skip this step and proceed to the next step.

2. Use a damp, water moistened (not wet), lint-free cloth to clean the paper path **only** in the green handle jam clearance areas as shown in the illustration.

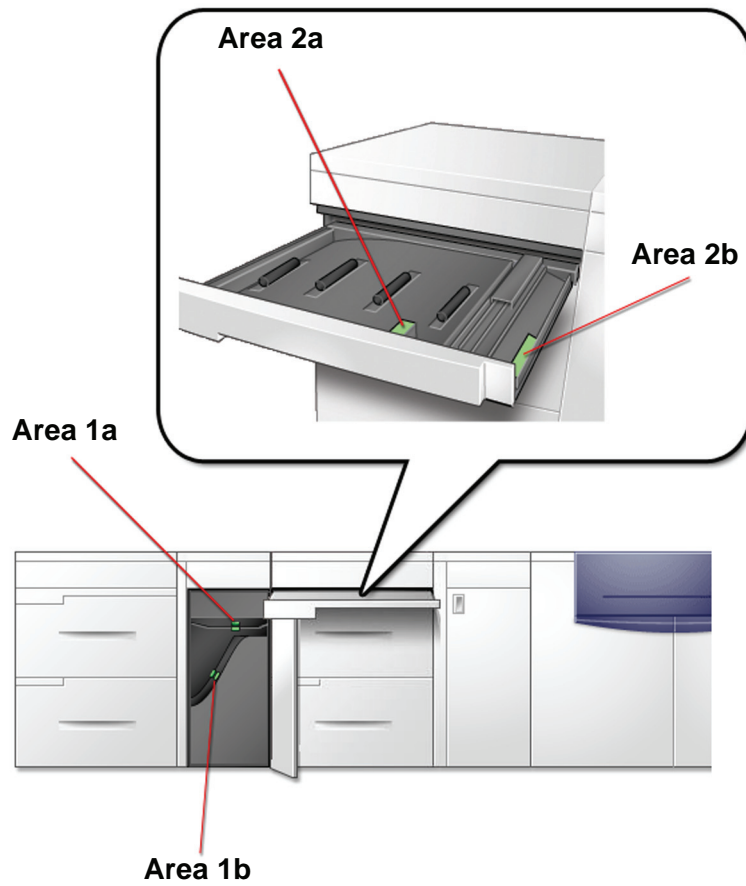

**3.** Use a damp, water moistened (not wet), lint-free cloth to clean the paper path **only** in the green handle jam clearance areas as shown in the illustration.

- a. Open each area and clean both surfaces of the transports.
- b. Remove any residual moisture with a dry, lint-free cloth.

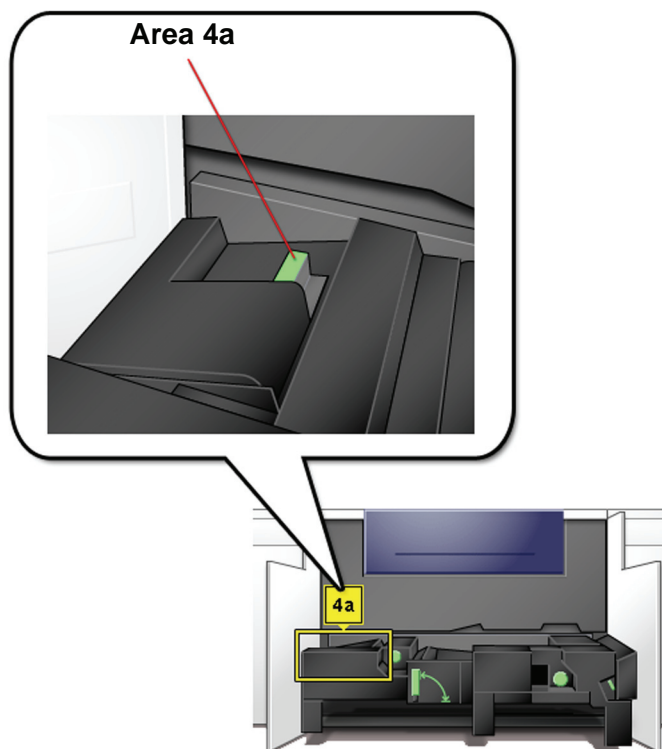

4. Use a damp, water moistened (not wet), lint-free cloth to clean the paper path **only** in the green handle jam clearance areas as shown below.

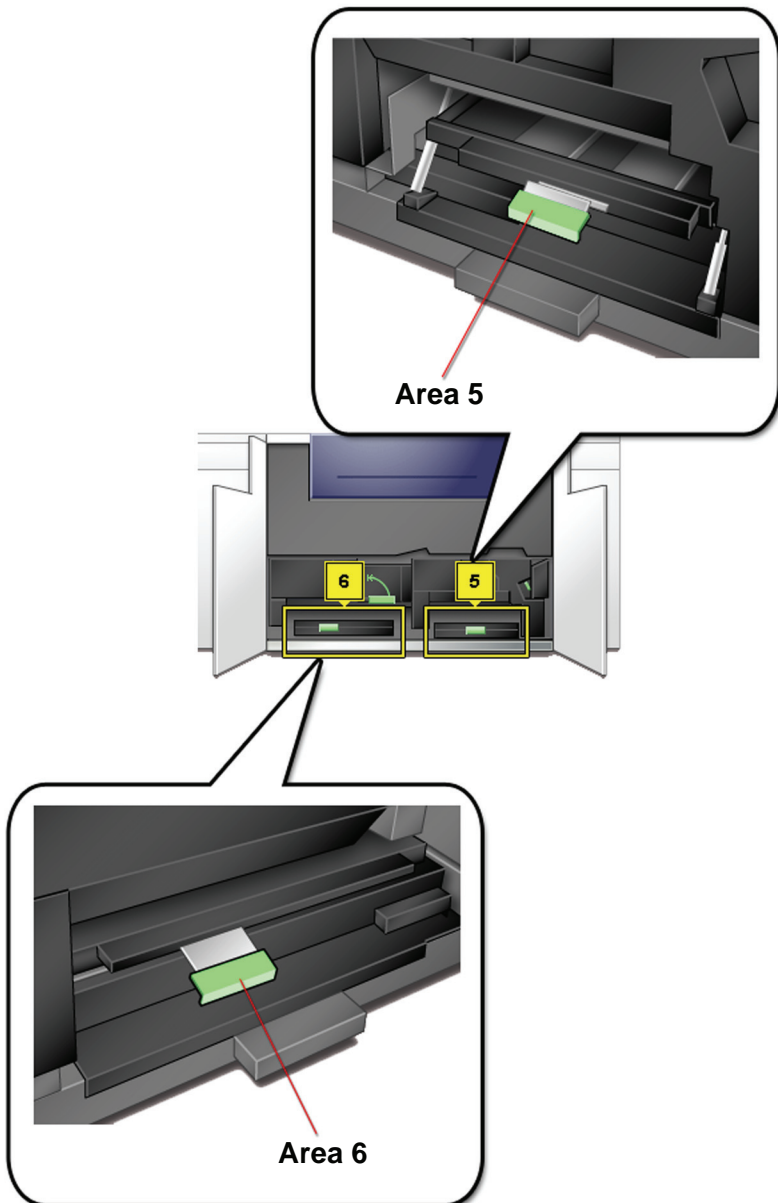

5. Use a damp, water moistened (not wet), lint-free cloth to clean the paper path **only** in the green handle jam clearance areas as shown below.

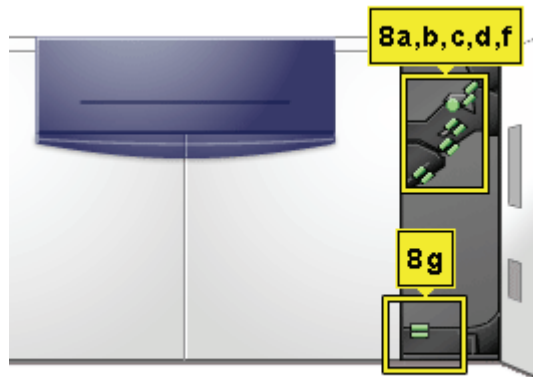

6. If large amounts of paper dust are frequently observed, contact your Xerox Supplies Representative for an alternate paper recommendation.



**NOTE:** *If Xerox analysis determines that persistent paper contamination is due to cut papers or the use of non-recommended material, the customer may be liable for extended costs outside the scope of the service contract.*

## Replacing Consumable Supplies

---

A message is displayed on the UI when a consumable item is nearing the replacement time. Another message is displayed when you must replace consumable items. The digital press will not run after this message is displayed until the item is replaced.

You should keep a supply available of the following consumable items:

- Dry Ink/Toner cartridges in all four colors
- An empty Waste Dry Ink/Toner bottle.
- Fuser Oil
- Fuser Web Assembly

A chart later in this chapter provides the part numbers to order.

## Replacing a Dry Ink/Toner Cartridge

Refer to the following procedure when a message to replace a Dry Ink/Toner Cartridge is displayed on the UI. There are also instructions on labels that are affixed to the compartment containing the cartridges.



**CAUTION:** To prevent spillage, remove Dry Ink/Toner cartridges only when the “**Replace the Dry Ink Cartridge**” message is displayed on the UI.



1. Place a drop cloth below the Dry Ink/Toner area.
2. Open the Dry Ink/Toner Compartment.



Dry Ink Compartment Door

3. Pull the cartridge completely out of the compartment.

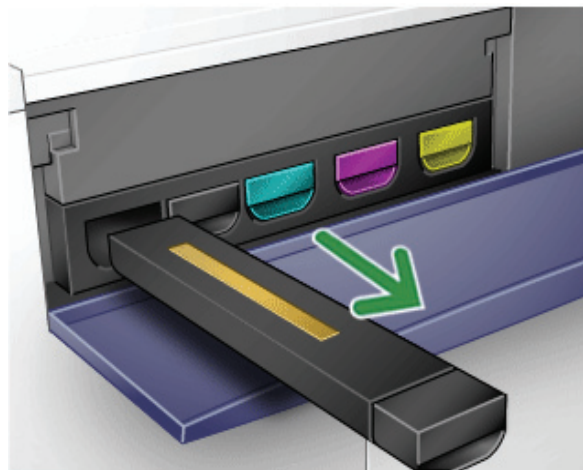

4. Dispose of the empty cartridge according to local regulations.



**TIP:** Do not use warm or hot water, or cleaning solvents, to remove Dry Ink/Toner from your skin or clothing. This will set the Dry Ink/Toner and make it difficult to remove. If any Dry Ink/Toner gets on your skin or clothing, use a brush to remove it, blow it off, or wash it off with cold water and mild soap.

**5.** Remove a new cartridge from the box.



**CAUTION:** Dry Ink/Toner settles and compacts during shipping and must be loosened before inserting the cartridge into the machine. Failure to completely loosen the material may cause damage to the gear at the end of the cartridge.



**TIP:** Vigorously shake and/or slap the new cartridge with your hand until the Dry Ink/Toner is completely loosened. Also, make sure that the gears spin freely.

**6.** Insert the cartridge into the compartment by sliding it into the compartment.

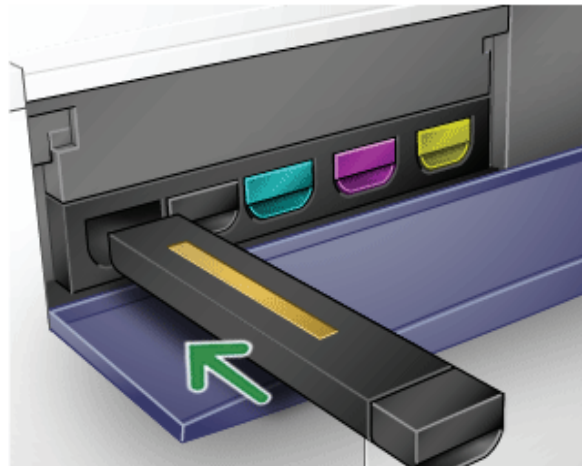

**CAUTION:** If more than one cartridge needs to be replaced at the same time, ensure that the cartridges are replaced in their correct color locations. From left to right, the cartridge colors are black 1, black 2, cyan, magenta, and yellow.

**7.** Close the Dry Ink/Toner compartment door.



## Changing the Dry Ink/Toner Waste Bottle

A message appears on the UI advising you when to replace the Waste Dry Ink/Toner Bottle.

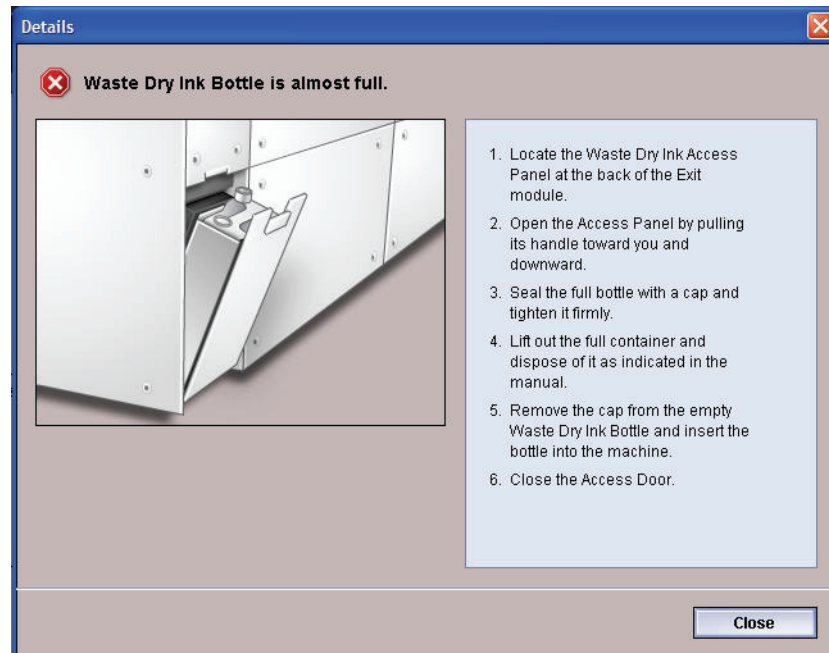

The bottle is located at the back of the machine.



1. Open the Waste Dry Ink/Toner door at the back of the machine.

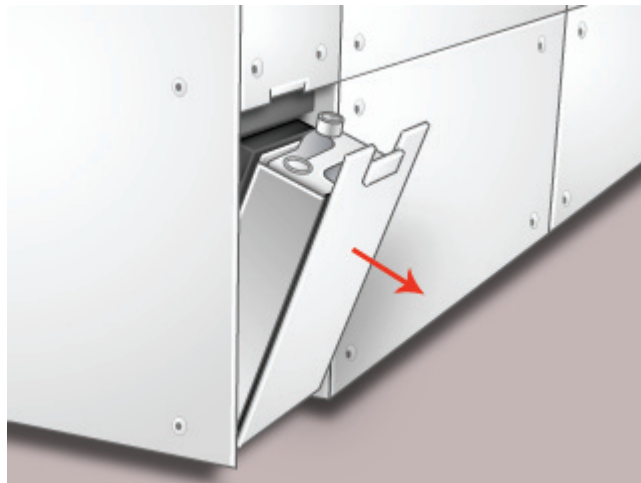

2. Grasp the handle of the full bottle and pull it out of the machine.

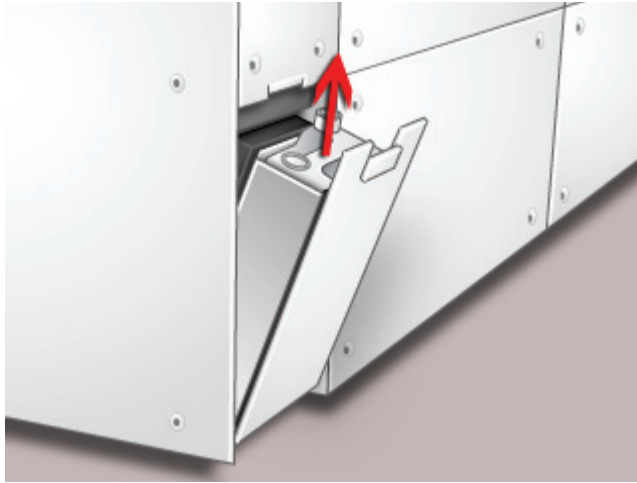

3. Remove the cap from the cap holder on the side of the full bottle and press the cap securely into the open hole on the top of the full bottle.

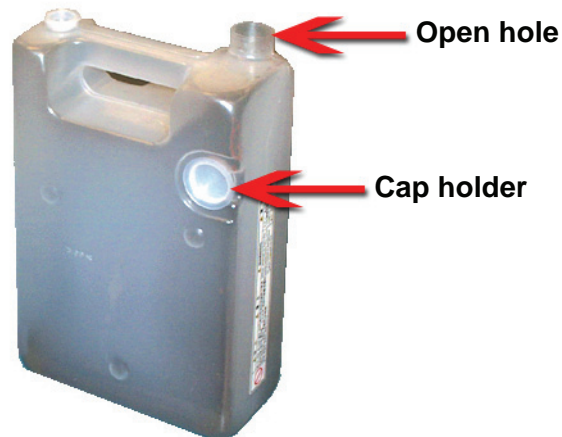

4. Dispose of the full bottle according to your local regulations.
5. Remove an empty bottle from the carton and insert it into the machine. Ensure that the hole on the top of the bottle is open and facing to the right.
6. Close the Waste Dry Ink/Toner Bottle door.

## Adding Fuser Oil

A message appears on the UI advising you when to add Fuser Oil. Use the following procedure to replenish the Fuser Oil supply.



1. Open the Right Front Door of the digital press.

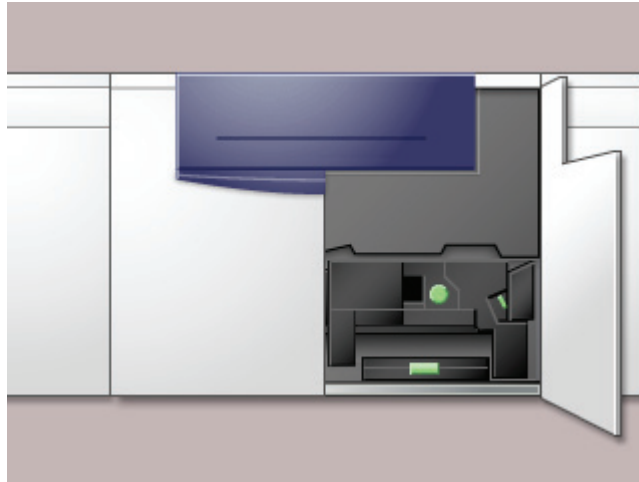

2. Place a drop cloth on the floor under the Fuser area. Any oil spilled on a hard floor will make the floor slippery.
3. To open the Reservoir Cap, grasp the tab at the back of the cap and pull it forward.

Refer to the following figure for the location of the Fuser Oil Reservoir Cap.

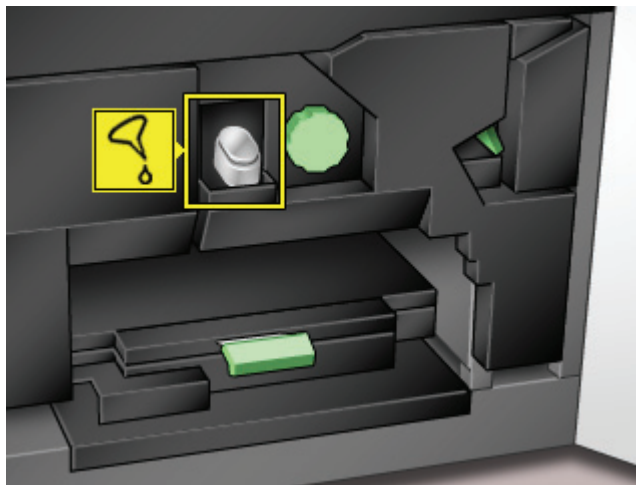

4. Remove the cap from the bottle of Fuser Oil and replace it with the Filler Spout Cap.

This cap was provided to you when your digital press was installed. Contact your Xerox service representative if you cannot locate the Filler Spout Cap and need another one.

5. Carefully insert the Filler Spout into the opened Fuser Oil Reservoir and squeeze the bottle until the oil reaches the maximum fill level tab visible inside the Reservoir.
6. Remove the Filler Cap from the bottle and place it on a cloth or paper towel to drain. Return the original cap to the bottle of Fuser Oil.
7. Close the Reservoir Cap, ensuring that it snaps into place.
8. Close the Right Front Door of the digital press.

### Replacing the Fuser Web Assembly

Two messages will display on the UI regarding the Fuser Web. The first advises you that the web is almost used up and you should be sure to have a new unit on hand. The second message displays when the Fuser Web is completely used and you must replace it. When this message displays, the digital press shuts down and will not print until the web is replaced.



**WARNING:** The Fuser area is hot. Be careful when working in this area to avoid injury.



Use the following procedure to replace the Fuser Web.

1. Open the front doors of the digital press.

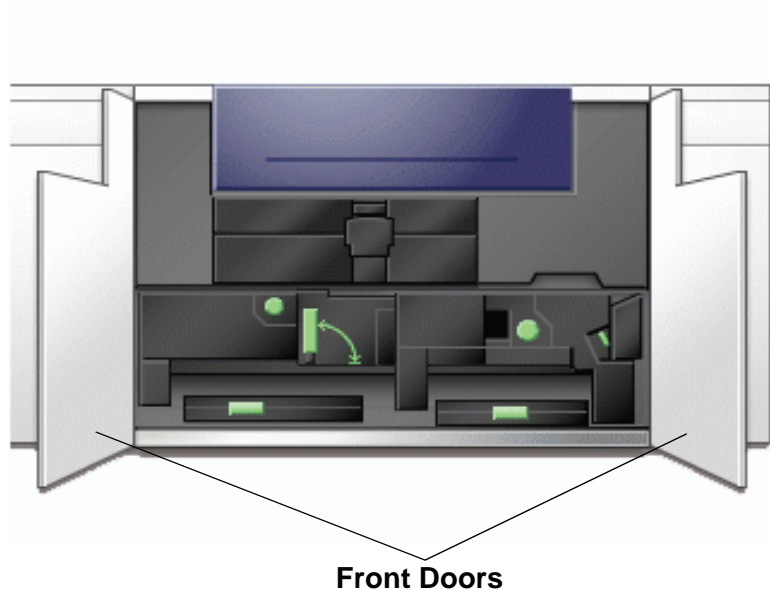

2. Grasp handle 4 and move it in the direction of the arrow.

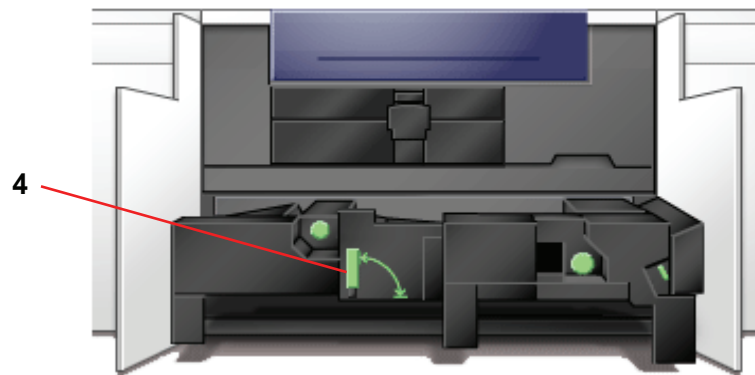

3. Slowly pull out the Paper Transport module until it stops.
4. Pull open the Fuser handle 4C.

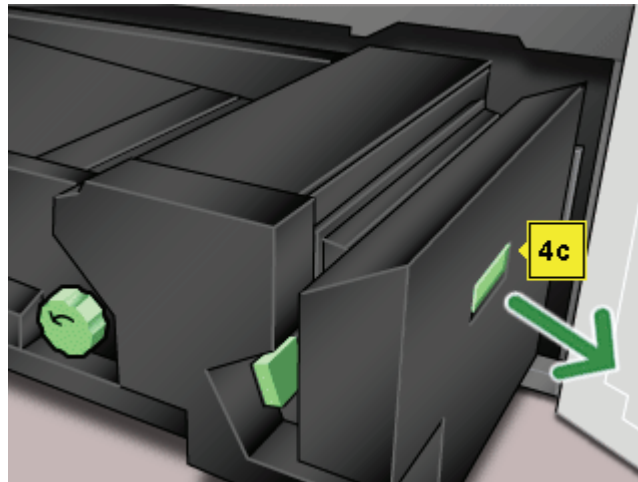

5. Lift up handle 4d until it stops at the top of the Fuser.

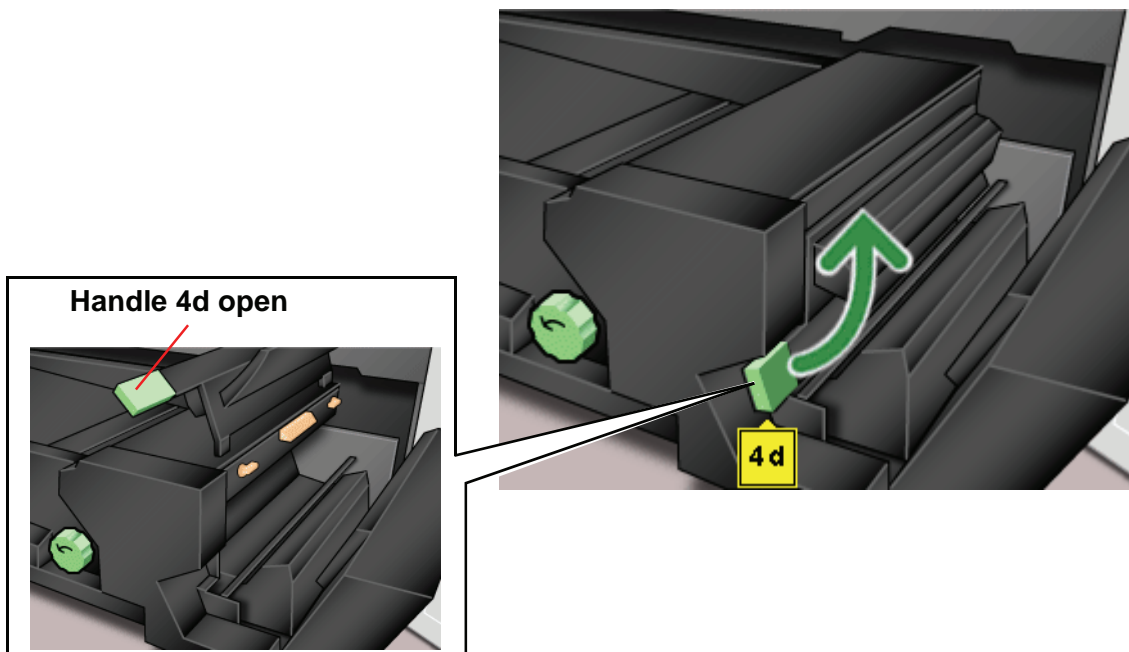

6. Push down the two levers.

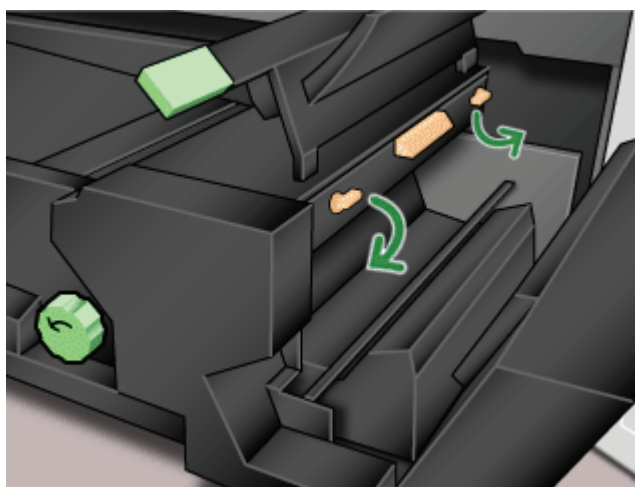

7. Grasp the colored handle in the center and pull the web unit down and out of the machine. Dispose of according to your local regulations.

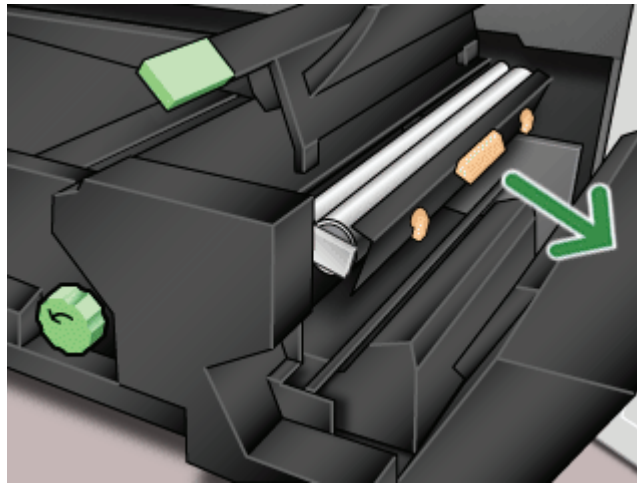

8. Remove the new web unit from the box and the protective covering.
9. Hold the web assembly with both hands and line up the tabs on both sides of the bottom of the assembly with the slides on both sides of the Fuser area. Slide the assembly in until it is firmly in place.

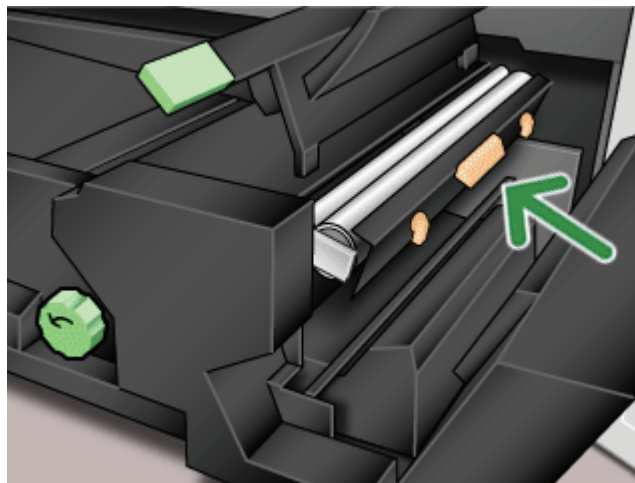

- 10.** Raise the unit to the upright position and push up the two orange levers.

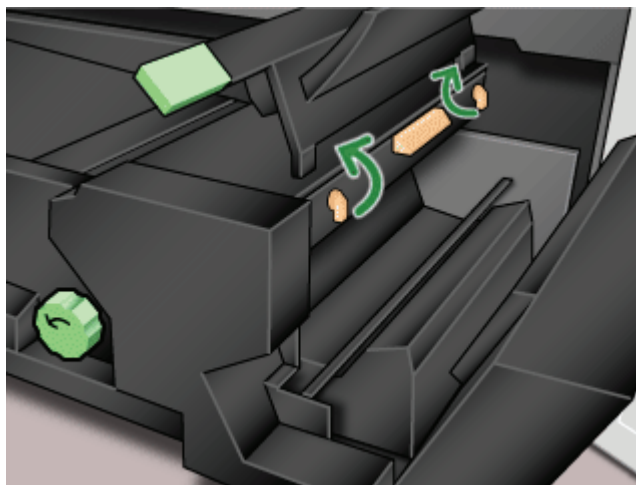

- 11.** Lower handle 4d.

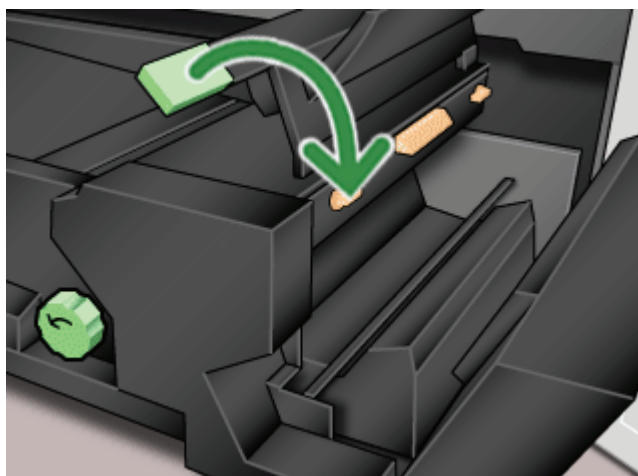



12. Lift up handle 4c and raise the Fuser into its original position.

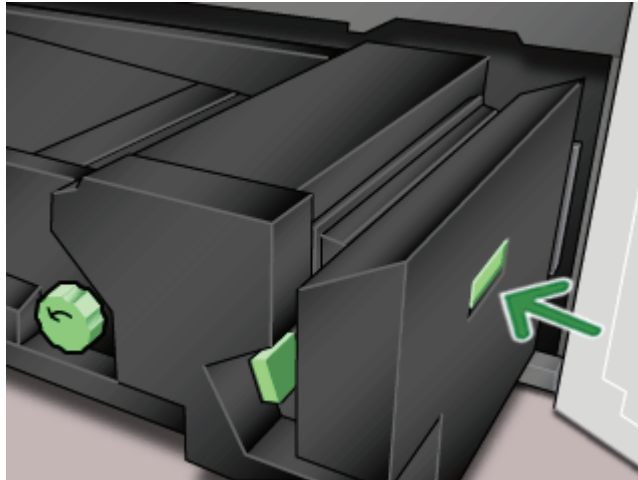

13. Grasp handle 4 and slowly push in the Paper Transport until it stops. Turn the handle in the direction of the arrow to lock the module in place.

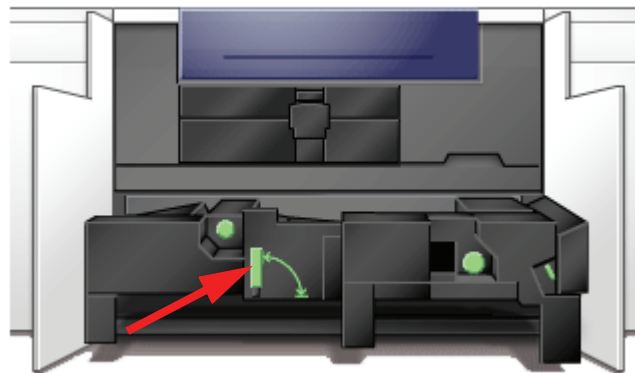

## 14. Close the right and left front doors.

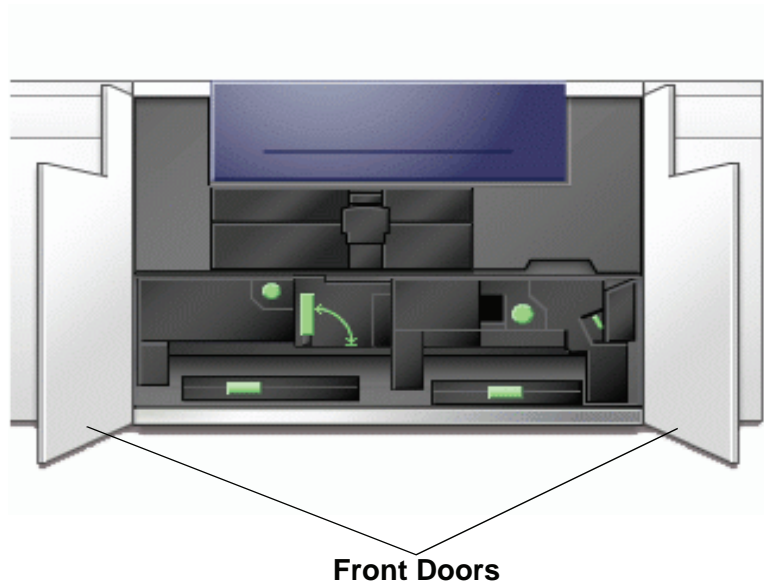

## Calling for Service

---

Refer to the UI when there is a problem with the digital press or an accessory. A status code and suggested solutions are displayed on the screen. Follow all steps in the suggested solutions until the problem is corrected. If the problem persists, call for assistance.

Follow the instructions below before calling for service.



1. Be prepared to provide a complete description of the problem to the service operator. Defining the problem accurately may help you and the operator solve the problem over the phone and minimize downtime. If the problem cannot be solved by telephone, a service representative will be dispatched to your site promptly.
2. Record the displayed Fault Codes.
3. Record the Machine Serial Number. Press the **Machine Status** button on the Control Panel. Touch the **Machine Details** tab and the serial number is displayed. (If the serial number is not displayed, open the Right/Left Front Doors of the digital press. The serial number is also on a white label on the bottom front frame.)
4. If copy quality is a problem, take a copy sample to the telephone with you to help you describe the problem or to assist you when answering the questions from the service operator about the defects.

5. If possible, use a phone near the press when calling for assistance. Follow the instructions provided by the operator.
6. For system support, user help, and service support, call the appropriate number:

US: **1-800-821-2797** (Includes TTY support)

Canada: **1-800-939-3769**

Europe: \_\_\_\_\_

Latin America: \_\_\_\_\_

Xerox also provides web-based customer support. Go to:

[www.xerox.com/eSupportCentre](http://www.xerox.com/eSupportCentre)

## Consumable Supplies

The following items are consumables for the DocuColor 5000AP. It is recommended that you have a supply of these items available to eliminate downtime when they need to be replaced.

Supply Item	Supply Number Eastern Hemisphere	Supply Number Western Hemisphere	Supply Unit Shipped with digital press/ Reorder Quantity	Approximate Print Yield/ Carton (Full Color Prints*)
Dry Ink/Toner Cartridge (Black)	6R1251	6R1247	2/box	22K
Dry Ink/Toner Cartridge (Cyan)	6R1252	6R1248	2/box	37K
Dry Ink/Toner Cartridge (Magenta)	6R1253	6R1249	2/box	37K
Dry Ink/Toner Cartridge (Yellow)	6R1254	6R1250	2/box	37K
Developer (Black)	5R711	5R711	1	100K
Developer (Cyan)	5R712	5R712	1	100K
Developer (Magenta)	5R713	5R713	1	100K
Developer (Yellow)	5R714	5R714	1	100K
Fuser Oil	8R13031	8R13031	1	200K
*Waste Dry Ink/Toner Bottle	8R90352	8R90352	1	50k
*Black Charge Corotron Unit	13R596	13R596	1	200K

## 7. Maintenance

Supply Item	Supply Number Eastern Hemisphere	Supply Number Western Hemisphere	Supply Unit Shipped with digital press/ Reorder Quantity	Approximate Print Yield/ Carton (Full Color Prints*)
*Fuser Web Assembly	8R12966	8R12966	1	120K
Black Drum Cartridge	13R617	13R613	1	278K
Color Drum Cartridge	13R620	13R616	1	115K
Paper	Xerox Digital Color Colotech+ 90g/m <sup>2</sup> (24 lb)	Xerox Digital Color Xpressions+ 90g/m <sup>2</sup> (24 lb)	2 reams	
Staple cartridge (for optional CSS)	8R12799	8R12799	1 box of 3 cartridges	

\* Please call your Xerox service representative to reorder Waste the Dry Ink/Toner Bottle, the Fuser Web Assembly, The Black Charge Corotron, and the Drum Cartridges. These parts are provided to you at no charge when ordered by a Xerox service representative.

Store supply items and Xerox parts in their original packages in a convenient location.

\* Dry Ink/Toner yield projections are based on 15 percent area coverage per color (4 colors = 60 percent) at standardized conditions on A4 (8.5x11") Xerox Digital Color Xpressions+, 24 lb. (90 g/m<sup>2</sup>) and Colotech Plus 90 g/m<sup>2</sup> reference paper.



**NOTE:** Actual yields vary greatly, depending on color intensity, area coverage, paper stock, and run mode selected.

To order consumable supplies, call the appropriate number:

US: **1-800-822-2200**

Canada: **French: 1-800-668-0133, English: 1-800-668-0199**

Europe: \_\_\_\_\_

Latin America: \_\_\_\_\_



