

Garden Light Speaker

Item No. 334202

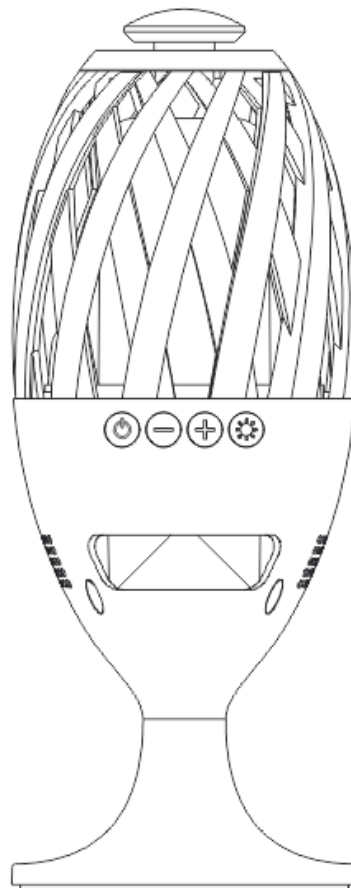

**Please read these instructions thoroughly
before use and retain for future reference**

Instructions for use

Please read all instructions carefully

Getting started

Remove the garden light speaker and accessories from the box

Remove any packaging from the product.

Place the packaging inside the box and store for safekeeping

In the box

Garden Light Speaker

Table Stand

Garden Spike

Micro USB Charging Cable

Instruction Manual

Features

- Garden Light Bluetooth speaker
- Bluetooth wireless connection functionality
- Flame Effect LED Light
- Built-in Rechargeable Battery
- IPX4 waterproof ~ can be used indoors and outdoors

Safety Instructions

- Keep the unit away from heat sources.
- Do not use the unit if it has been dropped or damaged in any way.
- Repairs to electrical equipment should only be performed by a qualified electrician. Improper repairs may place the user at serious risk.
- Do not put objects into any of the openings.
- Do not use this unit for anything other than its intended use.
- Keep the unit out of reach of children.
- This product is not a toy.
- Do not use abrasive cleaning solvents to clean.
- Do not operate around water (e.g. bathroom, swimming pool etc.)
- Do not expose to excessive heat such as sunshine, fire etc.
- Never immerse the unit in water or any other liquid for cleaning purposes.

Product Diagram

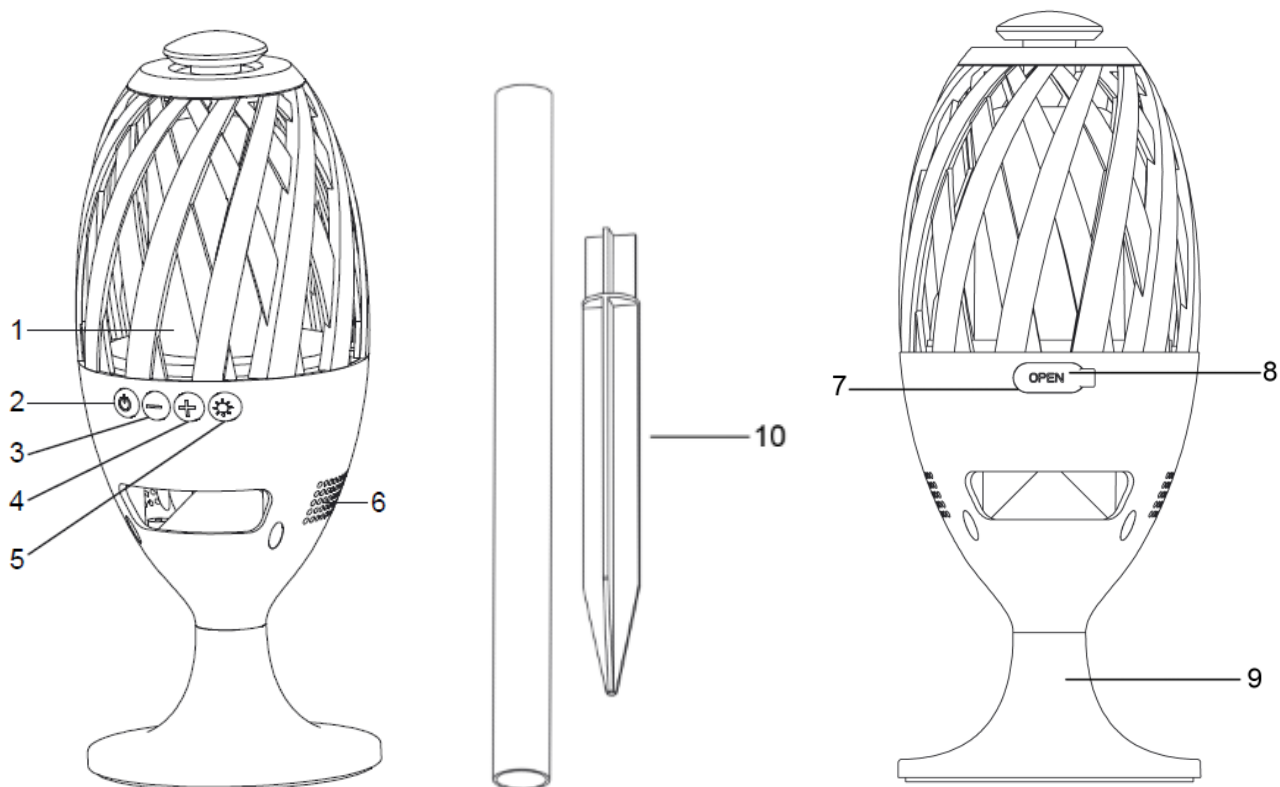

1	Garden Light	Flame Effect LED Light
2	Power Button	Hold the button for 3 seconds to turn the speaker ON or OFF. Press the button once and the speaker will Play or Pause.
3	-	Press the button once to return to the previous track. Hold the button to decrease volume level.
4	+	Press the button once to skip to the next track. Hold the button to increase volume level.
5	Garden Light ON / OFF Button	Press the button once to turn the flame effect LED light ON or OFF.
6	Speaker	Speaker.
7	Micro USB Port	DC 5 V charging port to charge the battery.
8	LED Indicator Light	Indicates the recharging status.
9	Table Stand	Use the table stand to place the speaker on the table.
10	Garden Spike	Assemble the garden spike and insert into the grass.

INSTRUCTION FOR USE

Charging Instructions

This Garden Light Bluetooth Speaker has a built in rechargeable battery.

Before using it for the first time we recommend you use the micro USB charging cable to charge the battery fully. Connect the USB cable to a USB port or a USB wall charger (not included) and connect the micro USB into the back of the speaker. The red battery charging LED indicator illuminates while the speaker is charging. When the battery is fully charged, the red LED indicator will turn OFF.

Garden Light

Press the ON/OFF button to turn the flame LED light ON or OFF.

Pairing the Garden Light speaker with Bluetooth devices (phone or music device)

Hold the power button for about 3 seconds to turn the speaker ON and the Bluetooth mode will open automatically, you will hear a “pairing” tone and the 4 buttons on the front of the speaker will flash.

Place the speaker and Bluetooth device (phone or music device) so that they are no further than 30 feet apart; Activate the Bluetooth function on your Bluetooth device (phone or music device). Please refer to the manufacturer’s instructions on how to enable Bluetooth on your device.

Once you have activated Bluetooth on your device, select the pairing name “**GARDEN1**” from the list of available Bluetooth devices. If required, enter the password ‘0000’ to confirm the pairing.

Once paired successfully, you will hear a “connected” tone indicating pairing successful.

You can now start to use the speaker.

Once you have paired the speaker with a device, the speaker will remember this device and will pair automatically when the device’s Bluetooth is activated and in range. You do not need to re-pair any previously connected devices.

The speaker will attempt to automatically connect to the last device it was paired with when the Bluetooth mode turn on. If you want to pair it with a new device, please turn OFF your last Bluetooth device (phone or music device) then use your new device to search and select the pairing name.

Once the speaker is paired with your device the music will transmit directly to the speaker. Please refer to your device’s user manual for further information.

Function Summary

Listening to Music

Once the speakers are paired with your device you can stream music wirelessly through the speaker. Select the track you wish to listen to and it will be streamed to your Bluetooth speaker. Should you encounter any problems while streaming please refer your device’s user manual for further information.

Note: An indication tone will alert you when the volume is adjusted to the maximum level.

Please Note

- Not all mobile phones support all the functions listed above. Please refer to your mobile phone's user's manual for further information.
- Certain functions and indication tones may vary depending on your mobile phone.

Cleaning & Maintenance

Turn OFF the speaker if it is left unattended and before cleaning.

NEVER immerse the speaker into water and please use a dry cloth for cleaning.

Storage

Turn OFF the power when you not in use, clean and store safety.

Do's and Don'ts

Read the following recommendations before using the speaker. Following these you will be able to enjoy the product for many years.

- Don't use abrasive cleaning solvents to clean the speaker.
- Do not expose the speaker to extremely high or low temperature as this will shorten the life of electronic devices, distorting certain plastic parts.
- Don't dispose of the speaker in a fire as it will result in an explosion.
- Don't expose the speaker to contact with sharp objects as this will cause scratches and damage.
- Don't attempt to disassemble the speaker as it may get damaged if you are not professional.
- Do not expose the speaker to heat or fire. Avoid storage in direct sunlight.
- Do not subject the speaker to mechanical shock.
- Do not add any fluids or solids to your speaker.
- Do not use the speaker if it has been damaged in any way.

Specifications

Bluetooth specification	Bluetooth V.4.2
Operating distance	10 meters (max.)
Frequency response	120HZ-20KHZ
Speaker power	1 x 3W
Built-in battery	3.7V / 1800mAh
Charging input voltage	DC 5V ---1000mA
Charging time	5-6 hours
Working time	3-4 hours
Product size	10x10x15.6cm

Note: Battery life & charging time may vary based on usage & types of devices used.



is a trademark on a registered trademark of
Bluetooth SIG Inc.

Declaration of Conformance

The full text of the EU declaration of conformity is available at the following internet address:

<http://www.bmstores.co.uk/technical-information>

Guidelines for protection of the environment



This appliance should not be put into the domestic garbage at the end of its useful life, but must be disposed of at a central point for recycling of electric and electronic domestic appliances. This symbol on appliance, instruction manual and packaging puts your attention to this important issue. The materials used in this appliance can be recycled. By recycling used domestic appliances you contribute an important push to the protection of our environment. Ask your local authorities for information regarding the point of recollection.

B&M L24 8RJ

Made in China



Guarantee

This product is guaranteed for twelve months from the date of original purchase.

If any defect should occur due to faulty materials or workmanship, the unit will either be replaced or refunded at our discretion.

You will need to have your receipt or proof of purchase.

The following conditions apply:

- The product must be returned to the retailer with original proof of purchase.
- It is only valid in the UK.
- It does not cover wear and tear, damage, misuse or consumable parts.
- The product must be correctly installed and operated in accordance with the instructions contained in the instruction manual.
- The product must be used solely for domestic purposes.
- The guarantee will be rendered invalid if the product is re-sold or has been damaged by inexpert repair.
- The guarantee is in addition to, and does not diminish your statutory or legal rights.

NOTE: This equipment has been tested and found to comply with the limits for a Class B digital device, pursuant to part 15 of the FCC Rules. These limits are designed to provide reasonable protection against harmful interference in a residential installation. This equipment generates uses and can radiate radio frequency energy and, if not installed and used in accordance with the instructions, may cause harmful interference to radio communications. However, there is no guarantee that interference will not occur in a particular installation. If this equipment does cause harmful interference to radio or television reception, which can be determined by turning the equipment off and on, the user is encouraged to try to correct the interference by one or more of the following measures:

- Reorient or relocate the receiving antenna.
- Increase the separation between the equipment and receiver.
- Connect the equipment into an outlet on a circuit different from that to which the receiver is connected.
- Consult the dealer or an experienced radio/TV technician for help

Changes or modifications not expressly approved by the party responsible for compliance

could void the user's authority to operate the equipment.

This device complies with Part 15 of the FCC Rules. Operation is subject to the following two conditions:

- (1) this device may not cause harmful interference, and
- (2) this device must accept any interference received, including interference that may cause undesired operation.