

# EAC Transceiver: Installation Guide

## 1

### CONNECTIONS

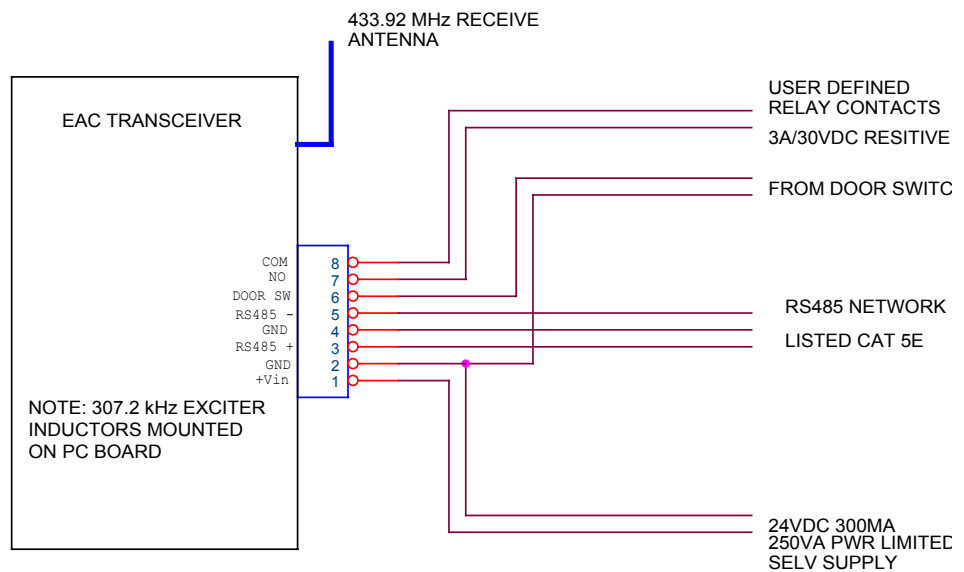
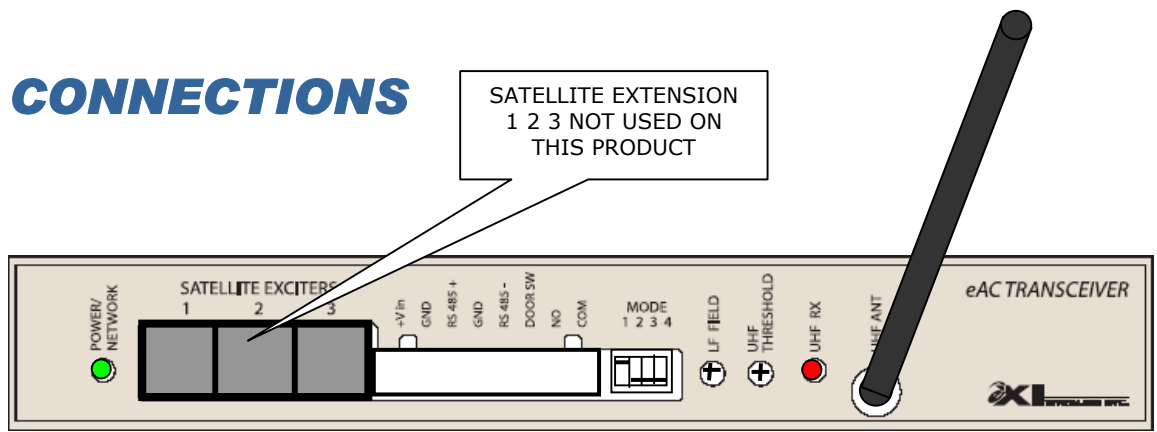

eAC System components are designed to meet the requirements for Class 2 circuits operating from a non-hazardous secondary power source limited to 240 VA. Cabling materials must be selected for the installation environment in accordance with the applicable jurisdictional codes.

## 2

### INSTALLATION

#### MOUNTING INSTRUCTIONS

The Controller chassis may be horizontally or vertically mounted on a wall, ceiling, or shelf as long as the front face panel is easily accessible. The RX antenna should be positioned on a vertical plane for maximum performance.

The detection field radiates from two internal orthogonal ferrite cored inductors. The field must fill the area in front of the door all the way to the floor so that no Tag can reach the door without being detected.

# 3 TUNING & ADJUSTMENT

**An eXI RF Test Tag is used for adjustment of the Receiver Threshold and LF Field Strength**

## **NETWORK STATUS**

Refer to eAC HUB network installation instructions for network cabling requirements.

<b>NETWORK STATUS INDICATOR LED</b>	<b>CONDITION</b>
OFF	No power to Receiver
Solid GREEN	Power supplied; Network normal
Flashing GREEN	Power supplied: Network Communication Failure

## **RECEIVER SENSITIVITY**

The UHF Threshold control may be adjusted to increase or reduce the range of detection of the UHF transmission of the Tags. Threshold adjustment removes some of the background noise, and reduces interference from Tags not within the field of the Transceiver.

Initially decrease the threshold (CCW) until the UHF RX indicator flashes occasionally. This will establish a threshold sensitivity to background noise at the door site. Using the RF Test Tag in the keyed mode, reduce the receiver sensitivity (increase threshold CW) until the RX indicator becomes intermittent at 25 to 30 feet. Reduce the threshold slightly and walk the tag around the area of coverage to check for consistent UHF reception.

## **LF FIELD ADJUSTMENT**

Adjust the LF Field for a compromise between maximum desired tag detection range and the potential to excite tags in adjacent rooms or floors. Note that the LF field tends to be omni-directional. Starting with the field adjustment at maximum (full CW), walk the RF Test Tag around the area of desired protection. Reduce the field until inconsistent tag identification occurs in parts of the coverage. (The UHF Threshold adjustment should be increased to check that the eLink is not being limited by the UHF link.) Increase the field strength in small increments until consistent detection results within the desired area of detection.

## **FCC Regulations**

This device complies with Part 15 of the FCC Rules. Operation is subject to the following two conditions: (1) This device may not cause harmful interference, and (2) This device must accept any interference received, including interference that may cause undesired operation.

This equipment has been tested and found to comply with the limits for Class B Digital Device, pursuant to Part 15 of the FCC Rules. These limits are designed to provide reasonable protection against harmful interference in a residential installation. This equipment generates and can radiate radio frequency energy and, if not installed and used in accordance with the instructions, may cause harmful interference to radio communications. However, there is no guarantee that interference will not occur in a particular installation. If this equipment does cause harmful interference to radio or television reception, which can be determined by turning the equipment off and on, the user is encouraged to try to correct the interference by one or more of the following measures.

- Reorient or relocate the receiving antenna
- Increase the separation between the equipment and Receiver
- Connect the equipment into an outlet on a circuit different from that to which the Receiver is connected
- Consult the dealer or an experienced radio/TV technician for help

Any changes or modifications not expressly approved by the party responsible for compliance could void the user's authority to operate the equipment.

## **EAC Transceiver: Installation Guide**

eXI Wireless Systems

CANADA: 2877A-EAC

Model No.: eAC Transceiver

FCC ID: HE7EAC

Made in Singapore

CAUTION – RISK OF EXPLOSION IF LITHIUM BATTERY IS REPLACED WITH AN INCORRECT TYPE. DISPOSE OF USED BATTERY ACCORDING TO THE INSTRUCTIONS OF THE MANUFACTURER.

eXI systems are designed to assist staff in providing a high degree of safety for people and therefore should only be used as a component of a comprehensive security program of policies, procedures, and processes. As with every security system, eXI highly recommends regular system operational checks to verify functional integrity.

© 2002 eXI Wireless Systems Inc. All rights reserved. eXI, eLink, and all respective logos are either trademarks or registered trademarks of eXI Wireless Systems Inc. Specifications subject to change without notice.  
eXI Wireless Systems Inc. · 100-13551 Commerce Parkway, Richmond, BC Canada V6V 2L1 · Phone (800) 667-9689 · Fax (604) 207-7760 · [www.exi.com](http://www.exi.com)