

Service and Status Lights

The Exciter has a service light and status light, which may be used to help diagnose problems in its operation. The service light is located beside the wire terminals, and the status light is located on the outside of the Exciter.

Service Light	
Off	Normal operation.
Momentary on	Service Pin pressed.
Flashing every 0.5 seconds	Unconfigured Exciter. Run Auto Configure.
On	Hardware failure. Download firmware to the Exciter from the LonWorks Device Installation dialog box.
Status Light	
Red	<p>Alarm or Device Error. Check for alarms and clear when security measures have been implemented. If condition persists, check operation of Exciter. Check the Exciter each time before moving to the next step.</p> <ol style="list-style-type: none"> 1 Press the Service Pin located on the front panel of the Exciter. An alarm should appear in the software. If not, check the wiring between the Exciter and the Controller PC. 2 Click on the Test button in the LonWorks Devices Installation dialog box. This checks the communications between the Exciter and the Controller. If a warning message appears, continue with the following steps. 3 Download firmware to the Exciter from the LonWorks Device Installation dialog box. 4 Reconfigure the Exciter. Run Auto Configure in the LonWorks Device Installation dialog box. 5 Reset the Exciter. Select the Exciter in the LonWorks Device Installation dialog box and click the Reset button. 6 Use the Download Neuron command to update the firmware. <p>If the above procedures do not fix the Exciter, replace it and check the replacement for coverage.</p>
Green	Armed.
Yellow	<ul style="list-style-type: none"> • Sign In / Sign Out in progress • Exciter permanently bypassed by the Controller PC. These Exciters do not activate alarms but do send a message to the Controller PC indicating a tag is within its detection area.
Flashing steady for 1 second, off for two seconds repeatedly (any color)	Wink command currently operating. The Controller PC is in the process of identifying this Exciter on the LonWorks network.

Warranty

VeriChip's products are warranted against defects in materials and workmanship and shall perform in accordance with published specifications for a period of one year. VeriChip reserves the right to change specifications without notice.

Limitation of Liability

This Product has been designed for use to assist in the prevention of infant abduction and/or mother/infant mismatching.

The range, accuracy, function and performance of this Product may vary from the published specifications due to many factors, including, without limitation, site impairments from structural effects, metal objects in the vicinity, placement of the receiver and transmitter, interference from other electrical devices, atmospheric effects, installation, and maintenance. There may be other factors, which also affect performance of this Product.



VeriChip does not guarantee that this Product will detect 100% of infant abductions and/or mother/infant mismatches. VeriChip does not guarantee that this Product will not return false reports of infant abductions and/or mother/infant mismatches.

Monthly testing and maintenance of this Product, as described in the Product documentation, is essential to verify the system is operating correctly and to ensure that the probability of detecting an alarm and/or locating the transmitter are maximized.

The failure to undertake regular testing and maintenance will increase the risk of system failure and failure to detect infant abductions and/or mother/infant mismatches. The failure to undertake regular testing and maintenance will increase the risk of false reports of infant abductions and/or mother/infant mismatches.

VeriChip hereby disclaims all warranties, express or implied, arising out of or in connection with any of its Products of the use or performance thereof, including but not limited to, where allowable by law, all other implied warranties or conditions of merchantable quality and fitness for a particular purpose and those arising by statute or otherwise in law or from a course of dealing or usage of trade.

VeriChip's liability to you or anyone claiming through or on behalf of you with respect to any claim or loss arising out of the use or misuse of VeriChip's Product, defective products or materials, improper installation or maintenance of VeriChip's Product or products or the system in which they are incorporated, or alleged to have resulted from an act or omission of VeriChip or any person, negligent or otherwise, shall be limited to:

- a) the repair or replacement of defective Product or materials supplied by VeriChip during the warranty period as set out in the Product documentation; or, at the option of VeriChip,
- b) refund of the purchase price of the Product supplied by VeriChip.

In no event shall VeriChip be liable for general, specific, indirect, consequential, incidental, exemplary or punitive damages or any losses or expenses suffered by you or anyone else, whether or not VeriChip, or its employees, officers, agents, resellers or installers has been informed of the risk of such loss or expense and whether or not such losses or expenses were foreseeable.

Statements

United States—Federal Communication Commission (FCC)

This device complies with Part 15 of the FCC Rules. Operation is subject to the following two conditions: (1) this device may not cause harmful interference, and (2) this device must accept any interference received, including interference that may cause undesired operation.

NOTE: This equipment has been tested and found to comply with the limits for a Class A digital device, pursuant to Part 15 of the FCC Rules. These limits are designed to provide reasonable protection against harmful interference when the equipment is operated in a commercial environment. This equipment generates, uses, and can radiate radio frequency energy and, if not installed and used in accordance with the instruction manual, may cause harmful interference to radio communications. Operation of this equipment in a residential area is likely to cause harmful interference in which case the user will be required to correct the interference at his own expense.

Warning: Changes or modifications not expressly approved by VeriChip could void the user's authority to operate the equipment.

Canada—Industry Canada

The term "IC:" before the certification/registration number only signifies that Industry Canada technical specifications were met.

European Union—CE declaration

VeriChip hereby declares that this radio frequency receiver is in compliance with the essential requirements and other relevant provisions of Directive 1999/5/EC.



Exciter Installation Guide

Part Number 806A6101



Have you:

- Pulled network and power cable?
- Resolved power supply requirements?
- Selected the location for the Exciter?

If you answered, "No," to any of these questions, refer to the Hugs Installation Manual before installing.



Read these instructions thoroughly before installing the Exciter. Faulty installation can lead to system failure.

Materials Required

- Exciter. Includes door contact, L-bracket, adhesive mount, cable ties, and bumpers.
- Facility floor plan indicating Exciter position and installation orientation, and network wiring path.
- 105 Ω network terminator (p/n 805A2401) required to terminate network. Two provided with each Controller (p/n 805A2201) or Laptop Controller (p/n 805A2202).
- Mounting hardware, all installations:
 - 4 Hollow wall anchors, for No. 10 wood screws
 - 4 No. 10 x 1" stainless steel wood screws
- Additional mounting hardware, L-bracket installations:
 - 4 No. 10 - 3/32" x 3/4" Philips/Pan head screws
 - 4 Stainless steel hex nuts
 - 4 No. 10 stainless steel flat washers
- Optional: Passive infrared sensor for open doorways where door contact cannot be used. Refer to Chapter 2 of the Hugs Installation Manual (p/n 805I0301) for important limitations on using PIR sensors.

Installation Considerations

- **Avoid metal**—Do not install the Exciter behind or within 2 inches (50 mm) of metal objects, including metal doors. These objects block the detection area of the Exciter.
- **Use door contacts**—Door contacts are required to minimize nuisance alarms.
- **Configure nearby Exciters as slaves**—Exciters installed within 30 feet (9 m) of each other must be configured as master and slave. Up to four slaves may be connected to one master.



309 Legget Drive, Ottawa, ON K2K 3A3, Canada
 Telephone: 1-866-559-6275 International: +1 613-592-6997 Facsimile: 1-613-592-4296
 Web Site: www.verichipcorp.com



- **Observe temperature and humidity restrictions**—Refer to the Specifications table.
- **Leave slack in the cable**—Leave at least 10 ft. (3 m) of slack in the communication and power cable to allow for adjustments in the location of the Exciter.
- **No user adjustments to internal circuitry**—Tampering may cause component or system failure, or both, and will void the warranty.

Important Reference Documents

- Hugs Installation Manual (p/n 805I0301)
- Hugs System Manual (p/n 805U1601)
- Exciter Tester Sheet (p/n 806U6301)

Specifications

Frequency	125 kHz
Supply Voltage	12-30 VDC
Current Draw	200 mA @ 24 VDC, 500 mA maximum
Relay Outputs (2)	30 VDC, 1 A, NO or NC
Detection Radius	Adjustable, up to 8.5 ft. (2.6 m)
Communications	LonWorks two wire
Temperature	Operating: 32°F to 120°F (0°C to 49°C) Storage: -40°F to 176°F (-40°C to 80°C)
Humidity	0-85% RH @ 70°F (21°C), non-condensing
Dimensions	Approximately 14.2 x 4.9 x 2 in. (360 x 124 x 50 mm)
Weight	Approximately 18.7 oz. (530 g)

© 2005 VeriChip Corporation. All Rights Reserved. Hugs and the Hugs logo are registered trademarks of VeriChip Corporation Inc. in North America. VeriChip and the VeriChip logo are trademarks of VeriChip Corporation. All other company and product names may be trademarks of their respective companies. Printed in Canada. August 2005. 806U6101 Rev 01.

Certified to the ISO 9001 Quality Standard

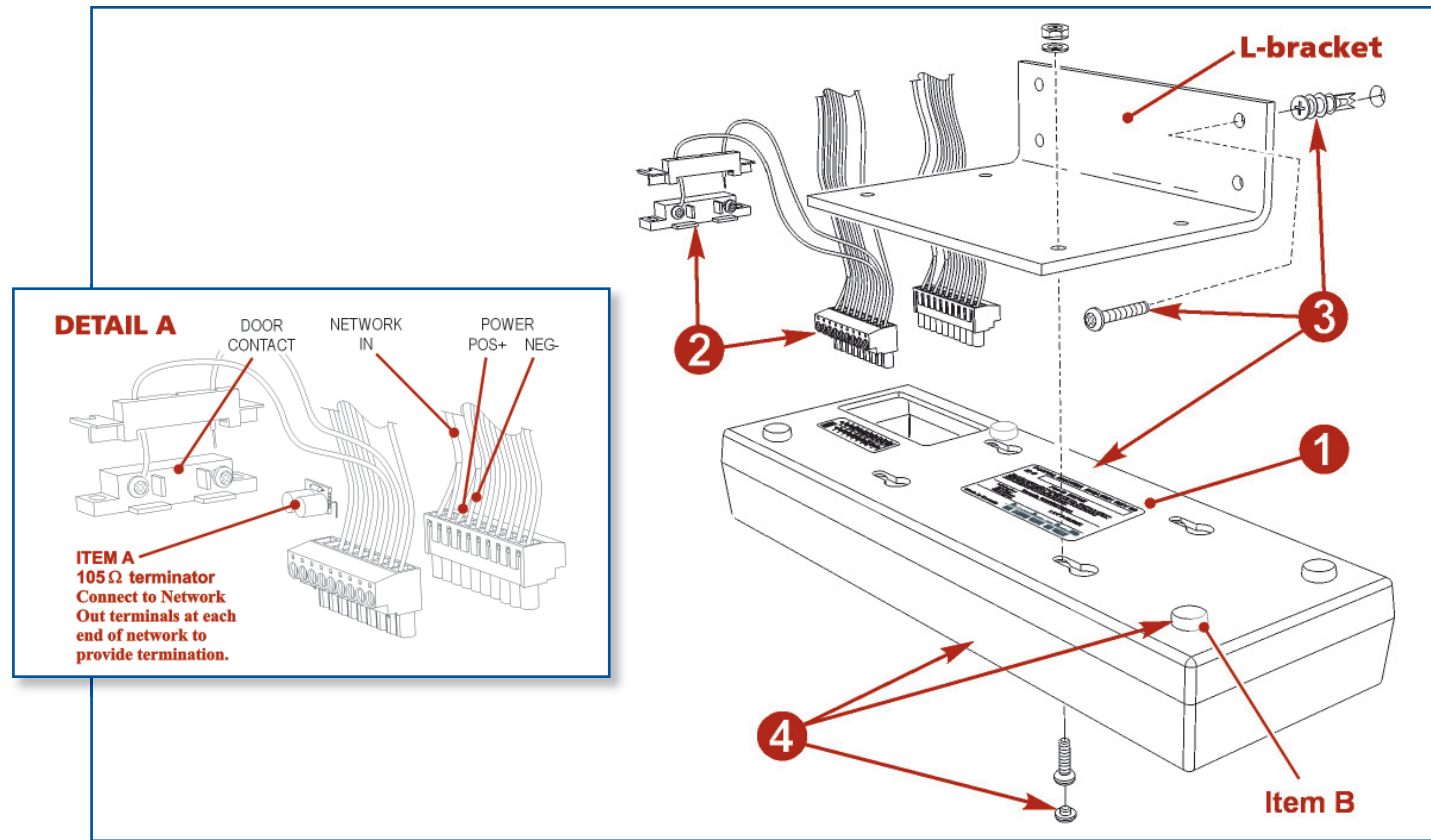

Installing the Exciter



- Ensure that the power supply and network are turned off to prevent electrical shock or damage to equipment.
- Touch your hand to ground to discharge any electrostatic charge before handling the Exciter.

The steps below correspond to the numbers in **Figure 1**.

- 1 Locate and record the LonWorks identification number onto the facility floor plan indicating the Exciter's position and network wiring path. Use the tear-away sticker on the Exciter's Neuron ID label.
 - 2 Install the supplied door contact or PIR sensor according to the manufacturer's instructions and connect it to the terminal, as shown in the wiring diagrams. Connect the LonWorks Network IN, Network OUT, and Power Supply to the terminal blocks, as shown in the wiring diagrams. If the Exciter is at the end of the network, then terminate the network segment with Item A (105 Ω terminator). Refer to **Detail A**, and insert the terminals into the connectors on the Exciter.
- Note:** If installing keypads or accessory devices, or if using a master/slave configuration, proceed to the relevant sections on the opposite page, and then return to steps 3 and 4.
- 3 Ensure that the status LED of the Exciter will be visible. Refer to the facility floor plan for location, and using the Exciter L-bracket as a template mark the location of the four mounting holes. Drill the holes.

- 4 Mount the Exciter.

L-bracket installations

- A Install in the four mounting holes: 4 hollow wall anchors
- B Attach the Exciter to the L-bracket, using: 4 No. 10 stainless steel machine screws
4 stainless steel hex nuts
4 No. 10 stainless steel flat washers
- C Attach the assembled Exciter and L-bracket to the previously installed hollow wall anchors, using: 4 No. 10 wood screws x 1 in. long

Surface mount installations

- A Install in the four mounting holes: 4 hollow wall anchors
- B Insert into the wall anchors, leaving 3/8 in. (0.5 cm) of the shaft exposed: 4 No. 10 wood screws x 1 in. long
- C If using surface wire conduit, attach the four supplied bumpons (Item B in **Figure 1**) to the underside of the Exciter.
- D Align the Exciter with the mounting screws, and while lightly pressing, slide until it is securely in place. Insert the supplied screw caps.

Installation is complete. Proceed to **Final Steps** below.

Installing Keypads

A single keypad may be connected to an Exciter to enable an infant to be signed out at the door. The keypad also releases the Exciter's relays, for example, to disengage a magnetic door lock. Hugs uses the Wiegand-standard KTP-103SN keypad, which offers individual passwords for each user.

Refer to the Hugs Installation Manual and the manufacturer's instructions. Keypads may be connected to either master or slave Exciter.

Note: The keypad requires a separate 12 VDC power supply.

Installing Accessory Devices

Each Exciter has two 30 VDC, 1 Amp, NO or NC relays for controlling accessory devices, such as magnetic door locks and high output alarms.

Refer to the Hugs Installation Manual and the manufacturer's instructions for installation procedures. Devices may be connected to either master or slave Exciters; connect devices to the master Exciter's relays first, then connect additional devices to the slave Exciter, starting with the closest.

Note: Accessory devices require their own power supply.

Master/Slave Installations

Master and slave Exciters are installed and connected to the LonWorks network in the same way as other Exciters, with the following additions:

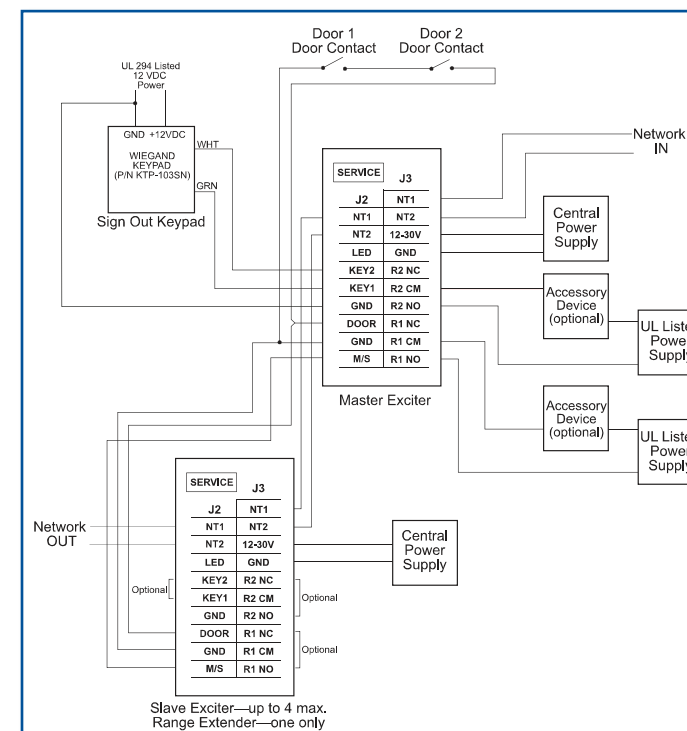

- All Exciters in master/slave group are connected in series through their M/S and ground terminals using 20 AWG wire, as shown in the wiring diagrams.

For slave Exciters using their own ID numbers, the following is also required, as shown in **Figure 3**:

- The mag lock (or elevator hold) outputs are wired to the relays on both the master and the slave to ensure that all doors in the vicinity will lock when a tag is present.
- Door contacts are wired together in series to the door contact input on both the master and the slave. The result is that when any door in a master/slave configuration is open, the system behaves as if all doors are open: an alarm will occur if a tag is at a door in the vicinity of a door that is open.

Final Steps



Do not supply power to the Exciter or any other network device until all connections are complete.

Once all devices are installed, power up the Exciter and other devices. In the Hugs system software, run Auto Configure to install the new devices, and then configure them for operation.

The coverage area of each Exciter must also be checked.

Refer to the Hugs Installation Manual (p/n 80510301) for detailed information on how to complete these steps.

