



# **Model AMP2440**

## **POLE MOUNTED BI-DIRECTIONAL POWER AMPLIFIERS FOR 2.4 GHz**



### **Installation and Operation Manual**

Version 2.4

July, 2001

8000 Lee Highway,  
Falls Church VA 22042  
Tel: (703) 205-0600 Fax: (703) 205-0610  
Sales: 1-888-297-9090

[www.ydi.com](http://www.ydi.com)

84 W. Santa Clara Street,  
Suite 760, San Jose, CA 95113  
Tel: (408)291-0998 Fax: (408) 291-0998  
Sales: 1-800-664-7060

## **LIMITED WARRANTY**

Young Design, Inc. (YDI) warrants that your device is free of defects in material and workmanship for a period of one year after initial purchase. YDI will, in this period of time, repair or replace, any YDI product returned to the factory, freight prepaid.

The YDI warranty covers repairs or replacement (at YDI's option) of the product only. YDI is not responsible for the cost of removal, reinstallation, or shipping to the place of repair. YDI does not extend or modify its warranty period as a result of repair or replacement.

YDI reserves the right to void a warranty and/or make reasonable charges for repair of a unit if the warranty seal is broken or the unit displays evidence of misuse, abuse, or tampering.

YDI is not responsible for damage to any other equipment or property, or any other consequential or incidental damages of any kind, whether based on contract, negligence, or strict liability. Maximum liability shall not in any case exceed the purchase price of the unit.

Warranties give you (the buyer) specific legal rights. You may also have other rights that vary from state to state. This warranty is only extended to purchases made in the United States of America or its possessions.

## **Warranty Notice**

The AMP2440 warranty is null and void if any of the following occurs:

1. The amplifier is opened.
2. The antenna connections are not properly waterproofed.
3. The amplifier is operated with no antenna attached.
4. Improper connectors are used.
5. The amplifier is mounted outdoors with the connectors facing any direction except downwards.

## **Important FCC Notice**

**This device complies with part 15 of the FCC rules. Operation is subject to the following two conditions: (1) This device may not cause harmful interference, and (2) This device must accept any interference received, including interference that may cause undesired operation.**

*© 2000, 2001 Young Design, Inc All Rights Reserved. No part or parts of this document may be reproduced, translated, stored in any electronic retrieval system, or transmitted, in any form or by any means, electronic, mechanical, photocopying, recording, or otherwise, without the prior written permission Young Design, Inc.*

# TABLE OF CONTENTS

1. DESCRIPTION.....	1
2. AMPLIFIER FEATURES.....	1
2.1 GENERAL SPECIFICATIONS.....	2
3. AMPLIFIER KIT.....	3
4. INSTALLATION AND CABLING INSTRUCTIONS.....	3
5. AMPLIFIER CONNECTIONS AND INDICATORS.....	5
6. DC POWER INJECTOR OPERATION.....	5
7. DC POWER INJECTOR CONNECTIONS AND INDICATORS.....	6
8. POWER SUPPLY.....	6
9. OPERATION.....	7
TABLE A - CONVERSIONS FROM DBM TO WATTS.....	9
TABLE B - TYPICAL CABLE ATTENUATION VALUES.....	9
<u>APPENDIX A: CALCULATING POWER</u> .....	10
<u>APPENDIX B: FCC PART 15 CERTIFIED SYSTEMS</u> .....	11

## **Professional Installation Required**

The amplifier and antennas used must be professionally installed by experienced antenna installation professionals who are familiar with RF issues (such as gains and losses) as well as local building and safety codes. Failure to do so will void the product warranty and may expose the end user to excessive Radio Frequency hazard. Regulations regarding maximum antenna gains, amplifier power gain, and maximum permissible exposure vary from country to country. It is the responsibility of the end user to operate within the limits of these regulations and to ensure that the professional installers who install this device are aware of these regulations. All antennas are intended to be installed outdoors.

## 1. Description

The AMP2440 is a bi-directional amplifier designed for extending the range of 2.4 GHz wireless radio modems, Wireless LAN cards, Access Points and wireless bridges. The units provide transmit power amplification as well as receive signal gain. The amplifier is installed right at the antenna's feed point, providing maximum effectiveness of transmit power. This has the effect of compensating for signal loss in the transmitter cable to the antenna. Likewise, the Low Noise Amplifier (LNA) in the AMP2440 boosts the receive signal right at the antenna prior to experiencing the loss in the transmission cable to the radio. This gain completely overcomes the losses in the transmission cable between the amplifier and the radio. This results in the lowest possible system Noise Figure. In fact, use of the amp will actually increase the receiver sensitivity by a few dB! The ultimate result is the best receiver sensitivity and maximum possible range for whatever antenna is used.

The amplifier box is weatherproof and can be bolted to the antenna mast or tower leg using the U-bolt included. When properly installed, the connectors face down so that gravity will drain all water away from the amplifier enclosure. This will prevent water from settling on the face of the unit. The LEDs will also be facing downward so that they can be checked for operation from the bottom of the mast or tower.

DC Power to the amplifier is supplied through the transmission cable that carries the RF (Radio Frequency) signal. This DC voltage is put on the coax cable using the DC Power Injector included in the amplifier kit. Both the amplifier and the DC Injector also contain their own integral lightning protection as well as DC surge protection. No external antenna lightning protection on the coax cable is required. (The DC Injector has a grounding stud to facilitate an easy connection to a good earth ground.) It also has mounting flanges to facilitate permanent installation to a bulkhead or wall. If mounted to a grounded metal plate, then no extra wiring need to be attached to the grounding stud. The amplifier box will provide maximum lightning protection when it is bolted to a grounded mast or tower. No extra ground straps need to be connected to the amplifier case.

## 2. Amplifier Features

- Transmit input levels from 3mW to 100mW
- 14 dB transmitter power gain (Standard amp)
- 16 dB receive gain
- RX preamp noise figure better than 4 dB (typical)
- Weatherproof Cast Aluminum Case that is mast mountable
- DC Power for the amp carried up through the transmission cable
- Power and Transmit LEDs on both the amp and the DC power injector
- Built-in Lightning Protection
- DC Surge Protection
- Heavy Duty N-type Connectors
- One Year Warranty
- Made in the U.S.A.

## 2.1 General Specifications

**Operating Range:** 2400-2483 MHz

**Operating Mode:** Bi-directional, half-duplex. Senses RF carrier from transmitter and automatically switches from receive to transmit mode.

**Connectors:** N-female

**Indicators:** TX and RX LEDs on both the amplifier and the DC bias injector

**Lightning Protection:** Direct DC ground at antenna connector. DC injector serves as lightning arrestor if properly grounded.

**DC Surge Protection:** 600 Watt TVS at 12 VDC input from transmission cable

### Transmitter Amplifier

**Transmit Gain:** 14 dB nominal for standard amp (Other versions may have different gains)

**Freq Response:** +/-1 dB over operating range

**Transmit Output Power:** 250 mW nominal  
Up to 640 mW for FHSS radios  
Up to 400 mW for DSSS radios

**Duty Cycle:** 50% Maximum

**Transmit Input Power to Amp:** 3mW minimum (+5dBm), 100mW (20 dBm) maximum (Special versions are available with higher input power).

### Model 2440 Functional Block Diagram

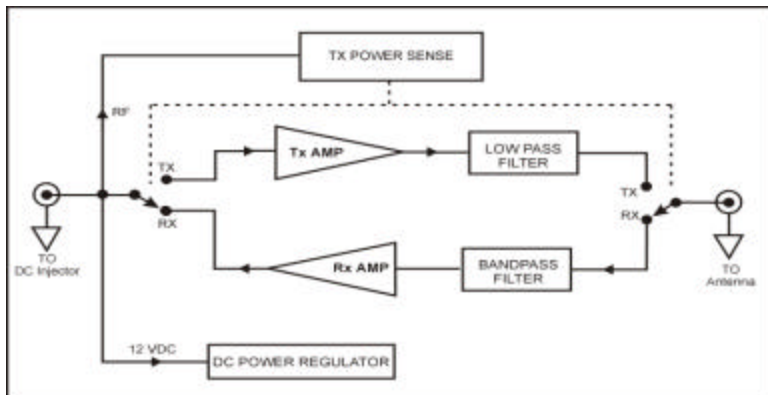

### Receiver Low Noise Amplifier (LNA)

**Receive Gain:** 16 dB nominal

**Freq Response:** +/-1 dB over operating range

**Noise Figure:** 2.8 dB typical, 3.8 dB max at room temp.

### Mechanical, Power and Environmental

**Operating Temperature:** 20°C to +60°C

**Power:** 105-240 VAC if using the power supply provided with the amp kit  
or  
11 - 14 VDC @ 900 ma peak, 400 ma avg. with an alternate power source

**Dimensions: Amplifier:** 4.5" x 2.6" x 1.2 "  
**DC Power injector:** 5.4" x 2.4" x 1.3 "

**Mounting Bracket for amplifier:** Accommodates pole/mast diameters from 3/4" to 3"

**Kit Weight:** Approx. 1.5 lb. with U-bolts



View showing the DC Injector and the pole mounted outdoor amplifier attached to its mounting bracket.

### 3. Amplifier Kit

Each Amplifier Kit Includes:

- Bi-directional remote mounted amplifier
- DC Power Injector
- 12 VDC, 110/220 VAC Power Supply
- Stainless Steel U-Bolts and mounting bracket for amp
- Installation Manual



Close up of the bracket and mounting hardware attached to the amplifier.

**IMPORTANT:**

Only mount the amplifier with the connectors facing downward. Do not mount it with the connectors facing sideways or upwards.

The following options are also available and must be ordered separately:

CAB-DC	DC power cable with 2.1mm plug to flying lead 3 feet long. Used when the customer provides their own 12 VDC power for the DC injector or amp.
Dual-DC	Option to add second power jack on DC injector to enable one 12 VDC PS that comes with the amp to power both the Injector and the radio or AP. (Requires a DC jumper cable. See below).
DC-2.1-2.1	DC jumper cable that connects a radio modem or Access Point to the second DC power jack on the DC injector box. Radio devices must have a 2.1 mm ID power jack and operate on 12VDC.
DC-2.1-2.5	Same as above except used for radios and Access Points that have a 2.5 mm ID barrel jack on them.

### 4. Installation and Cabling Instructions

**FCC Notice**

To comply with FCC part 15 rules, the proper version of the amp must only be used in systems that have been FCC certified. The system must also be professionally installed to ensure compliance with the Part 15 certification. It is the responsibility of the professional installer to ensure that certified systems be deployed in the United States (or where FCC rules apply). The use of the amplifier in any other combination (such as co-located antennas transmitting the same information) is expressly forbidden in accordance with FCC rules CFR47 part 15.204. Please visit our web site ([www.ydi.com](http://www.ydi.com)) to see the systems currently certified by the FCC.

Several key factors unique to their particular installation determine the power level at the input of the amplifier. The most important consideration is the cable loss in the transmission cable between the radio and the pole mounted amp. It is important that the installer understand these and other factors when installing the system.

If you are not familiar with determining power levels within the transmission system, YDI engineers will assist you in planning your system including selecting the proper cable and antenna required.

## SAFETY NOTICE

This equipment complies with FCC radiation exposure limits set forth for an uncontrolled environment when installed as directed. This equipment should be installed and operated with fix-mounted antennas that are installed such that the main lobe(s) of these antennas will have a minimum of 2 meters of separation distance between the antenna and all persons' body during normal operation.

The amplifier can be mast mounted using the steel U-bolt included with the unit. Refer to the drawing at the end of the manual for a cabling diagram. In outdoor applications, the amplifier must be installed with the connectors facing downward. Use an open-end wrench to carefully tighten the bolts using the included nuts. Take care not to over-tighten the bolts.

Alternately, the amplifier can be mounted to a flat surface using any of the mounting holes on the brackets mounting flanges. However, for maximum reliability the connectors should be facing downward.

It is very important to waterproof the RF connectors on the amp. However, it is recommended that you do not tape the connectors until after all system tests have been performed. Be sure to use a high quality weather resistant electrical tape and/or other water sealant method. Silicon sealants are not recommended since they are hard to work with, do not ensure a 100% waterproofing of the connectors and difficult to remove if ever necessary.



The picture to the left shows the amplifier in typical installation shown with the YDI Model PT2421 Grid Dish antenna vertically polarized. The location on the mast where the amplifier is mounted is not important: provided that the connectors face downward. (Note that when this picture was taken, the connectors were not taped yet nor was the cable secured to the mast.) Also, there is not need to plug or fill any of the holes on the back of the amplifier enclosure. The housing is designed such that these holes do not penetrate the inside of the waterproof seal even though an initial inspection might make you think otherwise.

If the tower or mast is adequately grounded and the U-bolt makes good electrical connection to it, then there is no need to provide additional grounding to the amplifier enclosure.

The DC Power Injector is not in a waterproof enclosure and must be protected from the weather. It can be permanently mounted to a surface using the mounting flanges. If not mounted to a well-grounded metal plate or bulkhead, then a separate ground strap will need to connect to the grounding stud on the Injector.

Refer to the Typical Installation Detail drawing at the end of this manual for more information about the installation.

## 5. Amplifier Connections and Indicators

**CAUTION:** Only use high quality N-type connectors. Do not use PL259 “CB” type UHF connectors. Doing so will ruin the N-Female jacks and void your warranty.

<b>Transmit LED:</b>	This LED glows RED when the amp has switched to the transmit mode. This occurs when the amp detects RF power at the jack labeled “To DC Injector”. (See Section 9 operation for more information)
<b>Receive LED:</b>	This LED glows GREEN in the receive mode when DC power is applied to the amplifier. It is goes off when; the amp is in the transmitting mode.
<b>DC Injector Connection:</b>	This N-type female connects to the DC Power Injector via the transmission cable. The length of this cable will determine the type of cable that should be used. See the installation diagram and the Appendix for more information.
<b>Antenna Connection:</b>	This N-type female connects to the antenna with a short length of low-loss coax cable.

## 6. DC Power Injector Operation

A DC Power Injector is an in-line device which “injects” the DC power necessary to operate the amplifier onto a transmission line. This allows the coax cable to carry both RF signals and DC power to the mast-mounted amplifier. This precludes the need to run a separate power cable to the remote mounted amplifier.

When grounded to a good earth ground through either the grounding stud or mounting flange, the DC Injector will provide maximum lightning protection to your radio modem, wireless LAN card or Access Point.



## 7. DC Power Injector Connections and Indicators

<b>Red Transmit LED:</b>	This LED glows RED when the pole mounted amplifier goes into transmit amplification mode. The Remote Transmit LED is controlled by unique circuitry, which actually detects changes in the DC current traveling through the transmission line to the amplifier. When you see this LED flash, you will know that the remote pole amplifier is going into transmit mode.
<b>Green Receive LED:</b>	This LED glows GREEN when DC power is applied to the amplifier and it is in the receive mode. When toggling between transmit and receive this LED will glow slightly dimmer.
<b>“To Radio” Connection:</b>	This N-type female connects to the radio via a short jumper cable.
<b>“To Amplifier” Connection:</b>	This N-type female connects to the amplifier on the mast using the coax transmission line.
<b>12 VDC:</b>	This is the DC power input for the injector and is a standard 2.1 mm barrel jack. +12VDC should be applied with center positive.
<b>AUX 12VDC: (OPTIONAL)</b>	This jack parallels the 12 VDC jack power jack. It can be used to provide 12 VDC to the radio modem or Access Point using a short DC jumper cable. Provided that the radio device operates on 12 VDC and draws less than 600 ma, the standard DC power supply that comes with the amplifier kit can be used to power both it and the amplifier/DC Injector. This extra jack is installed when the DC-INJ-DUAL option is ordered.

## 8. Power Supply

The AMP2440 kit comes with a 100 to 240 VAC power supply that has a standard 2.1 mm barrel plug [center pin positive (+) tip and outer ring negative (-)]. Although normally supplied with a power supply, any 12 Volt DC, 1 amp (or greater) regulated power supply can be used. The amplifier can operate from 11 to 14 VDC enabling battery or vehicle operation as well.

The DC power input is diode protected to prevent damage caused by reverse polarity input voltages as well as by an TVS to protect it and the amp from overvoltage surges.

## 9. Operation

The unit operates automatically and there are no user adjustments.

The amplifier is only intended for use with 2.4 GHz radio modems that alternate between transmit and receive in the same radio channel. These are referred to as Time Division Multiplex (TDD) devices. A typical example is an 802.11 WLAN card or Access Point. These modems “ping-pong” back and forth between transmit and receive so quickly during normal operation that both the TX and RX LEDs will appear to be lit simultaneously. In fact they are turning on and off so quickly that they appear to be on all the time. You can tell the duty cycle one of these LEDs by their brightness.

The amplifier will not work with radio modems or wireless bridges that are band-split true full duplex devices.

The amplifier provides for linear amplification for transmit output powers up to at least 400 mW. This is important for Direct Sequence Spread Spectrum (DSSS) radios, especially 802.11 devices. If you drive the amp so hard as to exceed 400mW output power, the amplifier will start to go into compression. This will result in raising the sidebands which will result in polluting the adjacent radio channels.

For Frequency Hopping Spread Spectrum radio devices, versions of the amplifier are available from the that have the output power limited to 250, 400 or 500 mW as specified in the FCC certified system. These amplifiers should not be used with DSSS radios since the transmit power limiting mechanism in the amplifier will cause it to go into compression when their respective clamped output levels are reached.

# TYPICAL AMPLIFIER INSTALLATION DETAILS

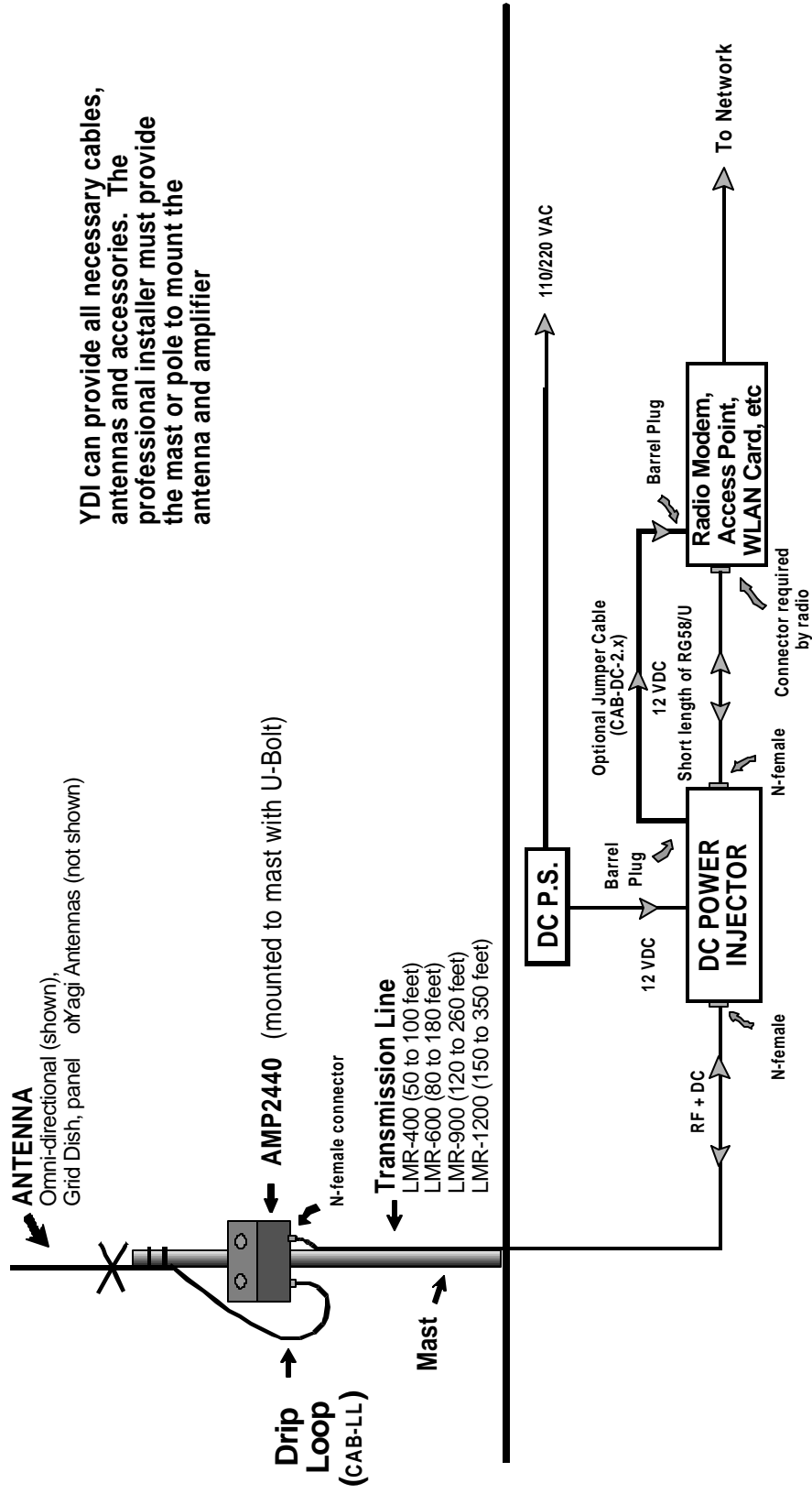

YDI can provide all necessary cables, antennas and accessories. The professional installer must provide the mast or pole to mount the antenna and amplifier

To enable the DC power supply to power both the DC injector and the radio, the amp kit should be ordered with the DUAL-DC option along with the appropriate DC Jumper cable.

**Table A - Conversions from dBm to Watts**

<b>dBm</b>	<b>Watts</b>	<b>dBm</b>	<b>Watts</b>
0	1.0 mW	26	400 mW
1	1.3 mW	27	500 mW
2	1.6 mW	28	640 mW
3	2.0 mW	29	800 mW
4	2.5 mW	30	1.0 W
5	3.2 mW	31	1.3 W
6	4.0 mW	32	1.6 W
7	5.0 mW	33	2.0 W
8	6 mW	34	2.5 W
9	8 mW	35	3.0 W
10	10 mW	36	4.0 W
11	13 mW	37	5.0 W
12	16 mW	38	6.0 W
13	20 mW	39	8.0 W
14	25 mW	40	10 W
15	32 mW	41	13 W
16	40 mW	42	16 W
17	50 mW	43	20 W
18	64 mW	44	25 W
19	80 mW	45	32 W
20	100 mW	46	40 W
21	128 mW	47	50 W
22	160 mW	48	64 W
23	200 mW	49	80 W
24	250 mW	50	100 W
25	320 mW	60	1000 W

**Table B - Typical Cable Attenuation Values**

<b><u>Cable Type</u></b>	<b><u>Attenuation per 100 ft at 2.4 GHz (dB)</u></b>
Belden 9913	8.0
LMR 200	16.8
LMR 240	12.9
LMR 400	6.9
LMR 600	4.4
1/2 "LDF	3.9
1/2" Superflex	6.1
3/8" LDF	5.9
3/8" Superflex	6.8
1/4" Superflex	9.8

These values are approximate. Check with cable manufacturers for exact specifications.

## **APPENDIX A: Calculating Power**

This appendix explains how to calculate the input power to the amplifier for your configuration.

1. Using Table A, convert the output power of the radio modem from Watts (or milliWatts) to dBm. The Model Amp 2440 amplifier works with input powers between 3.2 mW, +5 dBm, and 100 mW (+20 dBm).
2. Calculate the cable attenuation for your installation.

First, determine the attenuation for the length of your cable at 2.4 GHz. Use the cable manufacturer's specifications, or for convenience you may refer to Table B for typical values. (For example, Table B shows that typical attenuation for LMR-400 is about 6.9 dB per 100 foot at 2.4 GHz.) Then add 0.6 dB to that figure for connector, adaptor cable, and DC injector losses.

3. Calculate the maximum power that can be expected at the amp on the pole:

$$\text{Radio output (dB) - Cable loss (dB) - Connector Loss} = \text{Signal level at the amp's input (dBm)}$$

For example, a radio with 40mW (+16 dBm) output and 75 feet of LMR400 (about 3.4 dB of loss) would have the following input level to the amplifier:

$$+16 \text{ dBm} - 3.4 \text{ dB} - 0.6\text{dB} = +10 \text{ dBm}$$

Using a standard amplifier with 14 dB of linear transmit power gain, the output power is calculated as follows:

$$+10 \text{ dBm} + 14 \text{ dB gain} = +24 \text{ dBm output power (250 mW)}$$

If the input to the amplifier will exceed +20 dB (100 mW) by your calculations, an attenuator pad will be necessary between the modem and the DC injector. Or you can order a special version of the amplifier from YDI that will accept higher transmit input power.

Note: Never put attenuator pads between in the cable the DC injector and the amplifier since there is a +12V DC voltage on the cable. Doing this would prevent DC power from reaching the amp and will also damage the attenuator. However, a longer cable or one with higher loss could be used.

### Effective Radiated Power (ERP)

ERP is defined as the sum of the power feeding an antenna and the gain (in dBi) of that antenna. For example, with 250 mW (+24 dBm) of power into a 24 dBi gain grid dish antenna (like the YDI PT2424), the ERP would be:

$$+24 \text{ dBm} + 24 \text{ dB} = 48 \text{ dBm or 64 watts EIRP}$$

## APPENDIX B: FCC Part 15 Certified Systems

<b>FCC ID#: NM5-LUC2400E</b>
------------------------------

FCC certified systems consist of:

- A2440-xxF amplifier, DC Injector and 12 VDC Power supply
- Orinoco/Agere WLAN card with the FCC ID#: IMRWLPCE24H
- Outdoor Antenna
- Coax cable (See table B)

### Agere Authorized Antennas

Model	Antenna Type	Antenna Gain (dBi)	Max EIRP (dBm)	MPE Distance (CM)
Lucent AOU24-DI-24	Grid Dish Antenna	24	48	71
YDI PT2424	Grid Dish Antenna	24	48	71
YDI PT2421	Grid Dish Antenna	21	45	50
YDI A2.45FP18	Flat Panel Antenna	18	42	36
YDI A2.45FP15	Flat Panel Antenna	15	39	25
YDI A2.45FP12	Flat Panel Antenna	12	36	20
YDI A2.45FP17	Long Panel Antenna	17	41	32
YDI A2.45FP14	Long Panel Antenna	14	38	23
YDI A2410	Omni Antenna	12	36	20
Lucent AOU24-OD-10	Omni Antenna	10	34	20
YDI A2410	Omni Antenna	10	34	20
YDI A2408	Omni Antenna	9	33	20
Lucent XE 155845	Omni Antenna	6	30	20
YDI FP12A	Amplified Flat panel Antenna	12	36	32
YDI FP18A	Amplified Flat Panel Antenna	18	42	36

**FCC ID#: NM5-C111E**

FCC certified systems consist of:

- A2440-xxF amplifier, DC Injector and 12 VDC Power supply
- Nokia C111 WLAN card with the FCC ID#: ORE-C110-C111
- Outdoor Antenna
- Coax Cable (See table B)

**Nokia Authorized Antennas**

<b>Model</b>	<b>Antenna Type</b>	<b>Antenna Gain (dBi)</b>	<b>Max EIRP (dBm)</b>	<b>MPE Distance (CM)</b>
YDI PT2424	Grid dish Antenna	24	48	71
YDI PT2421	Grid dish Antenna	21	45	50
YDI A2.45FP18	Flat Panel Antenna	18	42	36
YDI A2.45FP15	Flat Panel Antenna	15	39	25
YDI A2.45FP12	Flat Panel Antenna	12	36	20
YDI A2.45LP17	Long Panel Antenna	17	41	32
YDI A2.45LP14	Long Panel Antenna	14	38	23
YDI A2412	Omni Antenna	12	36	20
YDI A2410	Omni Antenna	10	34	20
YDI A2408	Omni Antenna	9	33	20
YDI FP12A	Amplified Flat Panel Antenna	12	36	32
YDI FP18A	Amplified Flat Panel Antenna	18	42	36

FCC certified systems consist of:

- A2440-xxF amplifier, DC Injector and 12 VDC Power supply
- Agere WLAN card, PART#: 012699
- Outdoor Antenna
- Coax cable (See table B)

### Agere Short Card Authorized Antennas

Model	Antenna Type	Antenna Gain (dBi)	Max EIRP (dBm)	MPE Distance (CM)
Lucent AOU24-DI-24	Grid Dish Antenna	24	48	71
YDI PT2424	Grid Dish Antenna	24	48	71
YDI PT2421	Grid Dish Antenna	21	45	50
YDI A2.45FP18	Flat Panel Antenna	18	42	36
YDI A2.45FP15	Flat Panel Antenna	15	39	25
YDI A2.45FP12	Flat Panel Antenna	12	36	20
YDI A2.45FP17	Long Panel Antenna	17	41	32
YDI A2.45FP14	Long Panel Antenna	14	38	23
YDI A2410	Omni Antenna	12	36	20
Lucent AOU24-OD-10	Omni Antenna	10	34	20
YDI A2410	Omni Antenna	10	34	20
YDI A2408	Omni Antenna	9	33	20
Lucent XE 155845	Omni Antenna	6	30	20
YDI FP12A	Amplified Flat panel Antenna	12	36	32
YDI FP18A	Amplified Flat Panel Antenna	18	42	36



**Note:**

1. MPE distance figures are based on a conservative “worst case” prediction, i.e. +24 dBm into antenna using formula  $S=EIRP/(4\pi R^2)$  and no calculation for duty factor. In practice the minimum distance will be much shorter.
2. The minimum MPE distance has been calculated for the maximum allowed Power Density (S) limit os 1.0 mW/cm<sup>2</sup> in the Frequency range 1500-100,000 MHz for uncontrolled environments (Ref.2).

**Reference:**

1. FCC Part 15, sub-clause 15.247 (b)(4)
2. FCC OET Bulletin 65, edition 97-01
3. FCC Supplement C to OET Bulletin 65, edition 97-01

**TABLE B**  
**Authorized Cables with Minimum Lengths**

<b>Cable Type</b>	<b>Minimum Length/Loss</b>	<b>Max recommended Lengths</b>
RG58/U LMR195	19 Feet/3.4 dB	40 Feet
LMR200	20 Feet/ 3.4 dB	50 Feet
LMR240	25 Feet/ 3.3 dB	65 Feet
LMR400	50 Feet/ 3.4 dB	100 Feet
LMR500	60 Feet/ 3.5 dB	140 Feet
LMR600	80 Feet/ 3.5 dB	150 Feet
LMR900	120 Feet/ 3.5 dB	250Feet
LMR1200	150 Feet/3.4 dB	350Feet
LMR1700	200 Feet/3.4 dB	480 Feet

**NOTE:** This table is for reference only. In order to comply with FCC Part 15 Certification, the installer must insure that actual coax cable used between the DC injector and the amplifier has at least 3.3 dB of insertion loss.

**CAUTION:** If the power output from the amplifier exceeds +24 dBm or the antennas used are in excess of 24 dBi gain, the FCC regulatory limits specified in Part 15.247 (b)(3)(i) could be exceeded.

**To see a complete line of our High Speed  
Wireless Data products, visit our web site at:**

**[www.ydi.com](http://www.ydi.com)**

**or call our Sales Office at:  
1-888-297-9090**