

---

**TERABEAM**<sup>TM</sup> *WIRELESS*

# Marquee Point-to-Point Series User Guide

---

Contact Terabeam

[www.terabeam.com](http://www.terabeam.com)

8000 Lee Highway

Falls Church, VA 22042

Office: 703-205-0600

Fax: 703-205-0610

Sales: 1-888-297-9090

MNL-500274-001

Version 1.2

February 2005

---

**LIMITED WARRANTY**

Terabeam Wireless (Terabeam) warrants that your device is free of defects in material and workmanship for a period of one year after initial purchase. Terabeam will, in this period of time, repair or replace, any Terabeam product returned to the factory, freight prepaid.

The Terabeam warranty covers repairs or replacement (at Terabeam's option) of the product only. Terabeam is not responsible for the cost of removal, reinstallation, or shipping to the place of repair. Terabeam does not extend or modify its warranty period as a result of repair or replacement.

Terabeam reserves the right to void a warranty and/or make reasonable charges for repair of a unit if the warranty seal is broken or the unit displays evidence of misuse, abuse, or tampering.

Terabeam is not responsible for damage to any other equipment or property, or any other consequential or incidental damages of any kind, whether based on contract, negligence, or strict liability. Maximum liability shall not in any case exceed the purchase price of the unit.

Warranties give you (the buyer) specific legal rights. You may also have other rights that vary from state to state. This warranty is only extended to purchases made in the United States of America or its possessions.

**SPECIAL WARRANTY NOTICE**

The warranty is null and void if any of the following occurs:

1. The product enclosure is opened.
2. The connections are not properly waterproofed.
3. The device is installed improperly or with incorrect connectors.
4. The round connector of the outdoor Ethernet cable (if provided) is improperly plugged into the rear jack of the enclosure.
5. The device or DC Power Injector (if provided) are physically damaged.
6. The device is operated outside the recommended DC power specifications.
7. The device is damaged by extreme forces of nature, lightning, or 'Acts of God.'

**FCC NOTICE**

*This device complies with part 15 of the FCC rules. Operation is subject to the following two conditions:*

1. *This device may not cause harmful interference, and*
2. *This device must accept any interference received, including interference that may cause undesired operation.*

*\* Note: The manufacturer is not responsible for any radio or TV interference caused by unauthorized modifications to this equipment. Such modifications could void the user's authority to operate the equipment.*

*These products are labeled with one of the following FCC ID numbers:*

**FCC ID: NM5-MB-HP, NM5-MB-49, NM5-MB-49-HP**

## TABLE OF CONTENTS

<b>Section 1 Overview</b>	<b>1</b>
1.1 Description .....	1
1.2 Marquee Kit Contents .....	2
 <b>Section 2 Installation</b>	 <b>3</b>
2.1 Introduction .....	3
2.2 DC Power Injector .....	3
2.3 Power Supply .....	3
2.4 LEDs.....	3
2.5 Hardware Installation – FP Enclosure.....	4
2.6 Hardware Installation – EX Enclosure .....	6
2.7 Cabling the Marquee (All Enclosures) .....	8
2.8 Antenna Alignment.....	10
 <b>Section 3 Configuration</b>	 <b>15</b>
3.1 Installing the Management Software.....	15
3.2 Using the Configurator .....	15
3.3 Configuring the Marquee.....	16
 <b>Appendix A – Marquee Technical Specifications</b>	 <b>19</b>

**© 2005 Terabeam Wireless. All Rights Reserved.** No part or parts of this document may be reproduced, translated, stored in any electronic retrieval system or transmitted, in any form or by any means, electronic, mechanical, photocopied, recorded or otherwise, without the prior written permission of Terabeam Wireless.

*The information in this document is subject to change without notice. Although every effort has been made to make this manual accurate and complete, Terabeam Wireless assumes no responsibility for any errors that may appear in this document.*

## Section 1 Overview

### 1.1 Description

The Marquee™ Series is a powerful answer for customers seeking a reliable high-speed wireless connectivity solution. It provides the best features and wireless reach in the field by combining industry leading outdoor point-to-point (P-P) optimized software with its patented amplifier technology. Unlike other single band products, Marquee gives you the choice of installing a license-free 5.8 GHz, or a licensed 4.9 GHz network. If your needs change in the future, Marquee can change with you.

The Marquee P-P Series is comprised of Marquee Bridges. The Marquee is available in two types of enclosures: a flat panel (FP) and a ruggedized (EX) enclosure (see Figures 1.1a and b). The FP enclosure features a 23 dBi integrated antenna. The EX enclosure comes either with a 23 dBi flat panel antenna attached to the top of the unit, or it has an N-type connector on the rear to plug an external antenna. Table 1.1 shows the possible combinations of Marquee products, solutions and antennas that are offered. Refer to Appendix A for Marquee technical specifications.

**Table 1.1 – Marquee P-P Series and Antenna Combinations**

Enclosure	Type of Marquee	Type of Antenna	Model Number <sup>1</sup>
Ruggedized (EX) <sup>2</sup>	Bridge	Ordered separately	MPP49SEXN MPP49HEXN
		FP Attached (23 dBi)	MPP58HEX23A
		Dish 2 ft (28 dBi)	MPP58HEX28D
		Dish 2.5 ft (31 dBi)	MPP58HEX31D
		Dish 3 ft (34 dBi)	MPP58HEX34D
Flat panel (FP)	Bridge	FP Integrated (23 dBi)	MPP58HFP23I

<sup>1</sup> 49 = 4.9 GHz      S = Standard (Non-Amplified)

58 = 5.8 GHz      H = High Power (Amplified)

<sup>2</sup> Models with external antennas include one 6 ft LMR-600 coax cable per unit

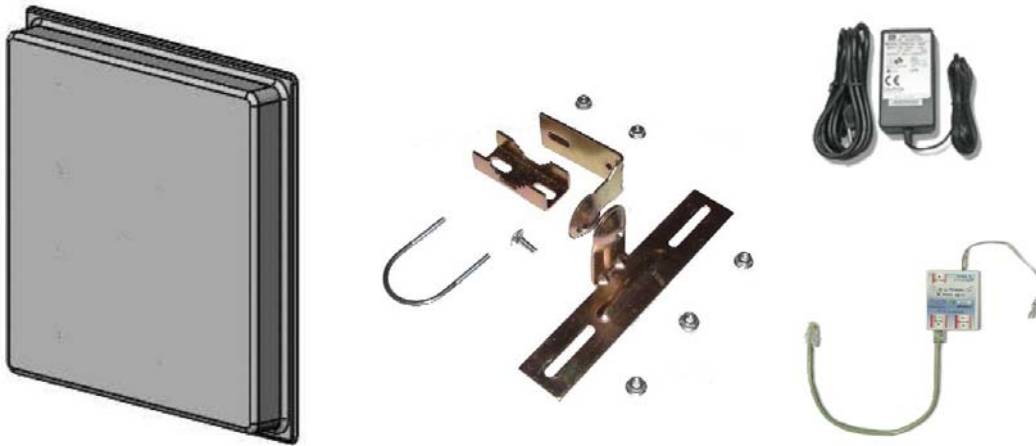
## 1.2 Marquee Kit Contents

Each Marquee kit includes the following (refer to Figures 1.1a and b):

- Outdoor radio with mounting hardware (two each)
- Surge protected Cat 5 DC Power Injector (two each)
- 110/240 VAC to 48 VDC power supply (two each)
- CD-ROM with Windows-based Configurator software
- User's Manual

A Terabeam outdoor Ethernet cable must be ordered separately per unit. Available lengths are 50, 100, 200, or 300 feet.

**Figure 1.1a – Components of Marquee FP Enclosure  
(Two Each for a Marquee Bridge P-P Configuration)**



**Figure 1.1b – Components of Marquee EX Enclosure  
(Two Each for a Marquee Bridge P-P Configuration)**



## Section 2 Installation

### **Safety Warning**



*This equipment complies with FCC radiation exposure limits set forth for an uncontrolled environment when installed as directed. The equipment should be installed and operated outdoors with fix-mounted antennas such that there will be a minimum of 2 meters of separation distance between the antenna and all persons during normal operation. This includes integrated, attached and external antenna versions of equipment. If you are using dish antennas, the minimum separation distance must be 2.56 meters.*

### 2.1 Introduction

The Marquee is intended for professional installation only. Please review the entire manual before powering up or deploying these units.

**NOTE:** It is strongly recommended that you configure and test the units prior to deploying them in the field. Set up a “mini-network” that resembles your actual configuration as close as possible. By using such a mock-up, troubleshooting potential problems will be much easier than if you already installed the equipment in the field. Read through this entire Section 2 to understand how to install the hardware. To configure the Marquee, read Section 3.

### 2.2 DC Power Injector

The Cat 5 DC Power Injector is not in a waterproof enclosure and must be protected from the weather. It can be permanently mounted to a surface using the double stick tape found on the back of it.

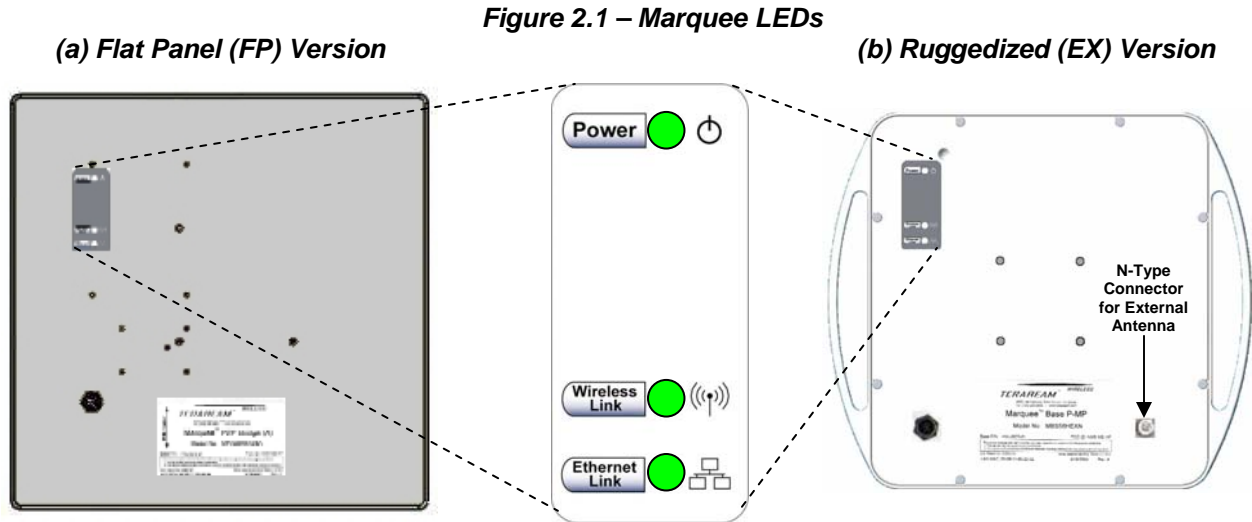
### 2.3 Power Supply

The Marquee kit comes with a 110/220 VAC to 48 VDC power supply that has a standard barrel plug [center pin positive (+) tip and outer ring negative (-)].

### 2.4 LEDs

Three LEDs are present on the back of the Marquee (see Figures 2.1a and b):

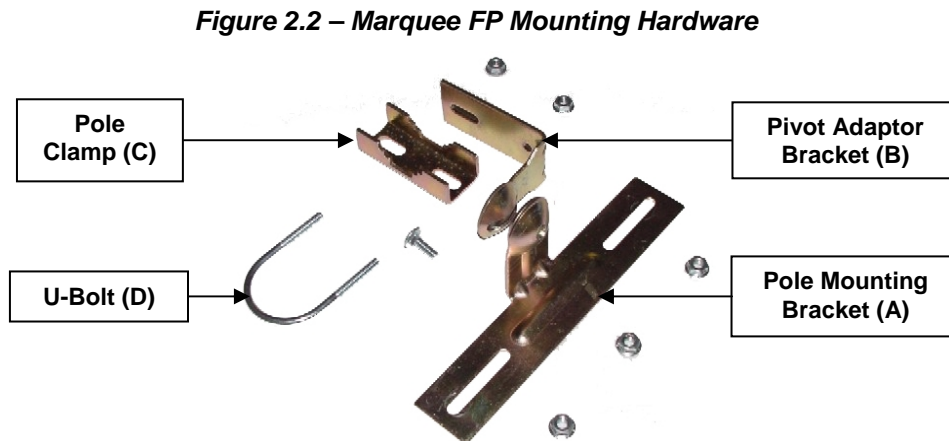
- The green Power LED stays on when the unit is plugged and operating correctly
- The green Wireless Link LED flashes when there is traffic over the wireless medium
- The green Ethernet Link LED flashes when there is traffic over the Ethernet port



## 2.5 Hardware Installation – FP Enclosure

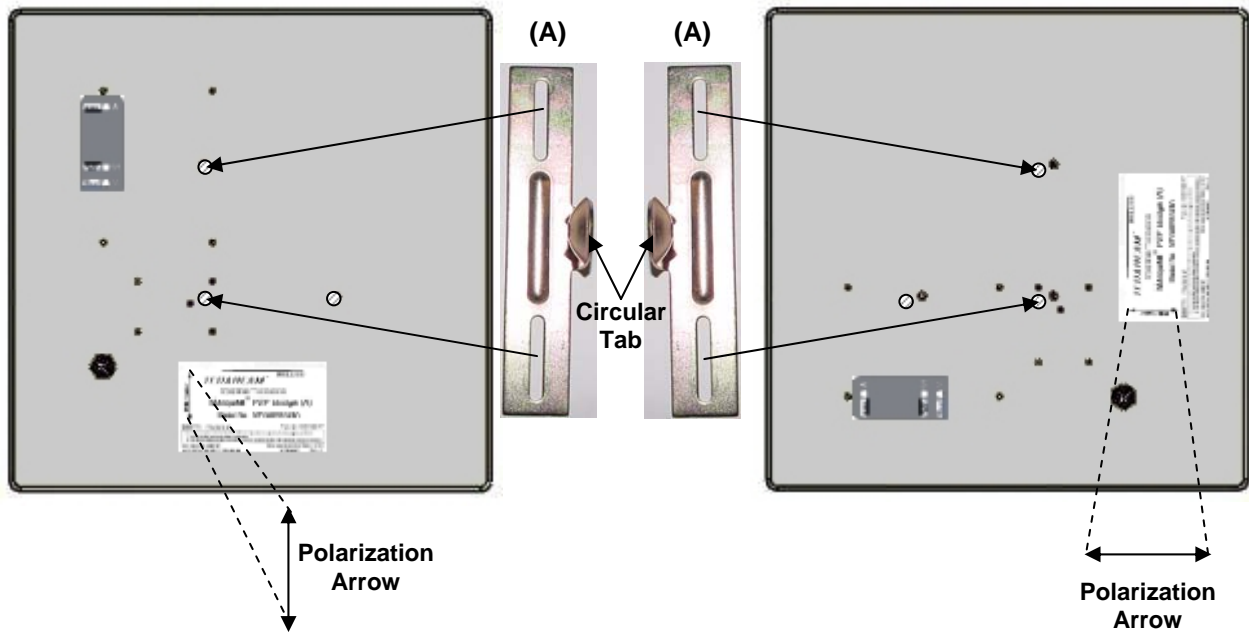
**NOTE:** All connectors must be properly water-proofed with all-weather electrical tape, Permagum, or equivalent. Do not use Silicon glue.

The Marquee FP unit is installed by using a pole mounting bracket (A) that is secured to the pole with a pivot adaptor bracket (B), a pole clamp (C), and a U-bolt (D). Figure 2.2 shows the hardware provided to mount the Marquee FP unit.



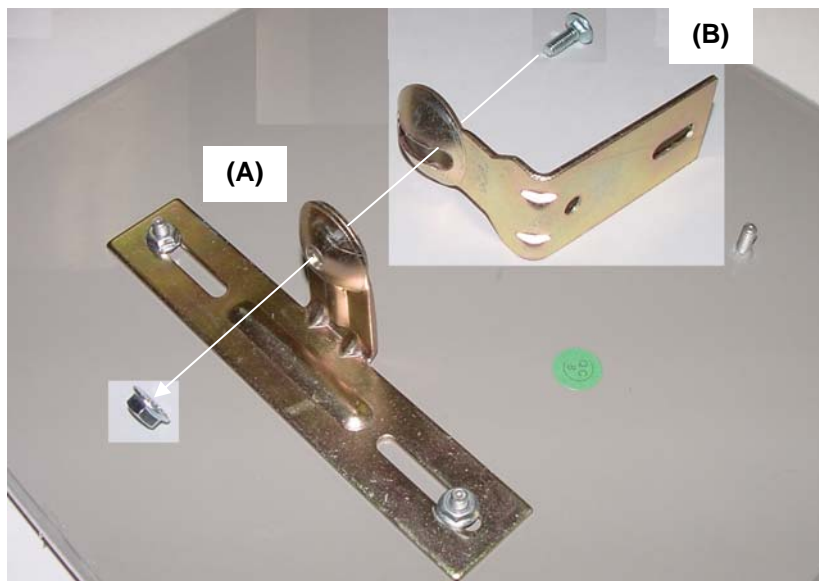
The integrated antenna can be mounted either vertically or horizontally polarized. The label located on the back of the unit contains an arrow indicating the antenna's polarization (see Figures 2.3a and b). Please note that both ends of the link must use the same polarization. Be aware that most omni antennas are vertically polarized and if the Marquee FP is aimed at one, it must be installed vertically polarized, i.e., with the polarization arrow up and down.

**Figure 2.3 – Marquee FP Orientation**  
**(a) For Vertical Polarization**                      **(b) For Horizontal Polarization**



1. Fit the pole mounting bracket (A) to the two studs protruding from the back of the Marquee FP unit according to the desired polarization, as shown in Figures 2.3a and b. Position the bracket so that the side that has the circular tab is pointing towards the center of the unit. Secure to the unit by threading two nuts and tighten them firmly with an appropriate wrench.
2. Attach the pivot adaptor bracket (B) to the pole mounting bracket (A) by using bolt and nut, as shown in Fig 2.4. Tighten hardware (one place). **IMPORTANT:** Ensure that convex edge of the pivot adaptor bracket (B) is facing concave edge of the pole mounting bracket (A).

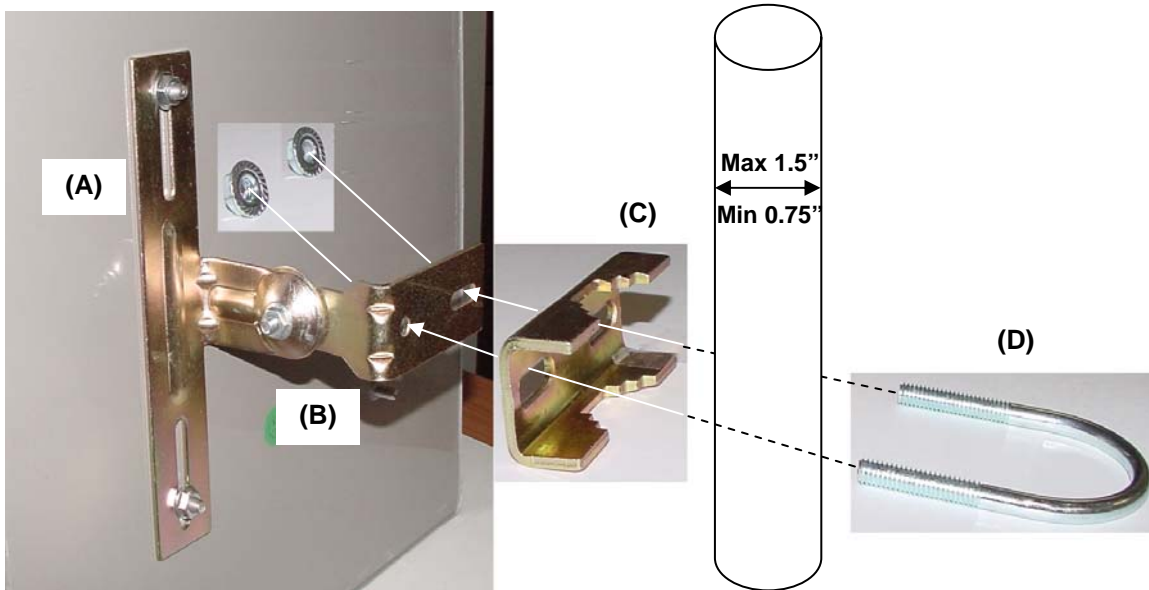
**Figure 2.4 –Assembly of Pivot Adaptor Bracket (B) to Pole Mounting Bracket (A)**





- Turn the pivot adaptor bracket (B) so that the rectangular part is parallel with the surface of the Marquee FP. Fasten the Marquee unit to the pole using pole clamp (C), U-bolt (D), and two nuts, as shown in Fig 2.5. Tighten hardware (two places). The pole clamp (C) and U-bolt (D) will accept pole diameters between 0.75" to 1.5" OD.

**Figure 2.5 – Attaching the Marquee FP Unit to the Pole**



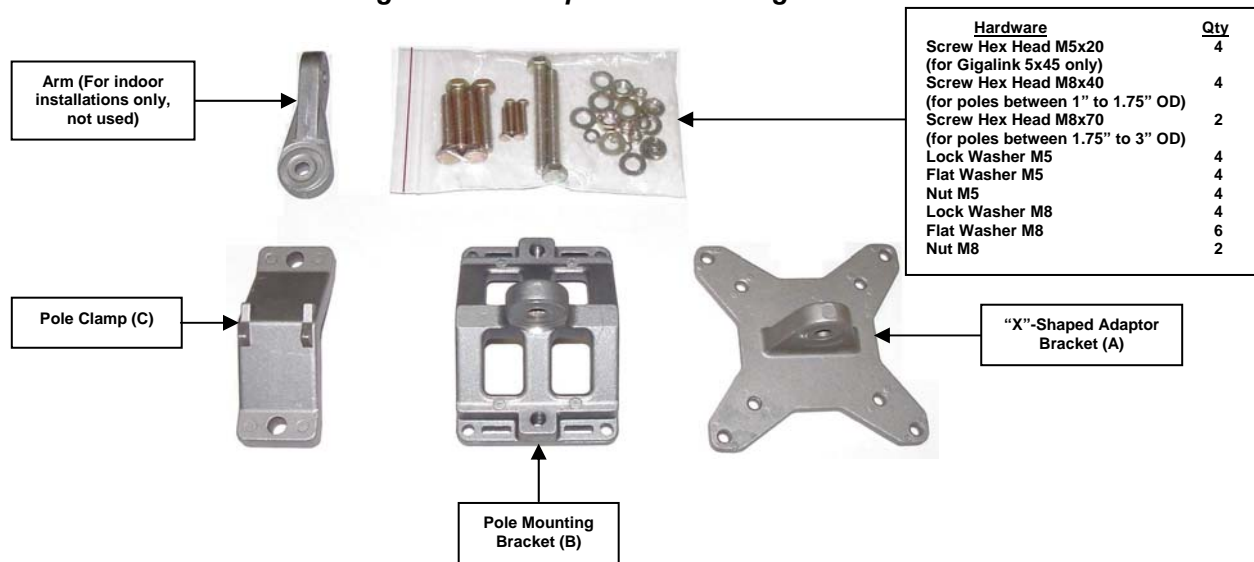
Proceed to Section 2.7 – Cabling the Marquee (All Enclosures).

## 2.6 Hardware Installation – EX Enclosure

**NOTE:** All connectors must be properly water-proofed with all-weather electrical tape, Permagem, or equivalent. **Do not use Silicon glue.**

The Marquee EX unit is installed by using an “X”-shaped adaptor bracket (A) that is secured to the pole with a pole mounting bracket (B), and a pole clamp (C). Figure 2.6 shows the hardware provided to mount the Marquee EX unit.

**Figure 2.6 – Marquee EX Mounting Hardware**



The antenna can be mounted either vertically or horizontally polarized. If you are using a Marquee with a 23 dBi FP attached antenna, the label located on the back of the unit shows an arrow indicating the antenna's polarization (see Figures 2.7a and b). Please note that both ends of the link must use the same polarization. Be aware that most omni antennas are vertically polarized and if the Marquee EX is aimed at one, it must be installed vertically polarized, i.e., with the polarization arrow up and down. If you are using a Marquee with an external antenna, there is no arrow on the label located on the back of the unit and an additional N-type female jack is present to connect a short coax cable to the antenna (see Figure 2.1b). All previous considerations regarding polarization are applicable to the external antenna.

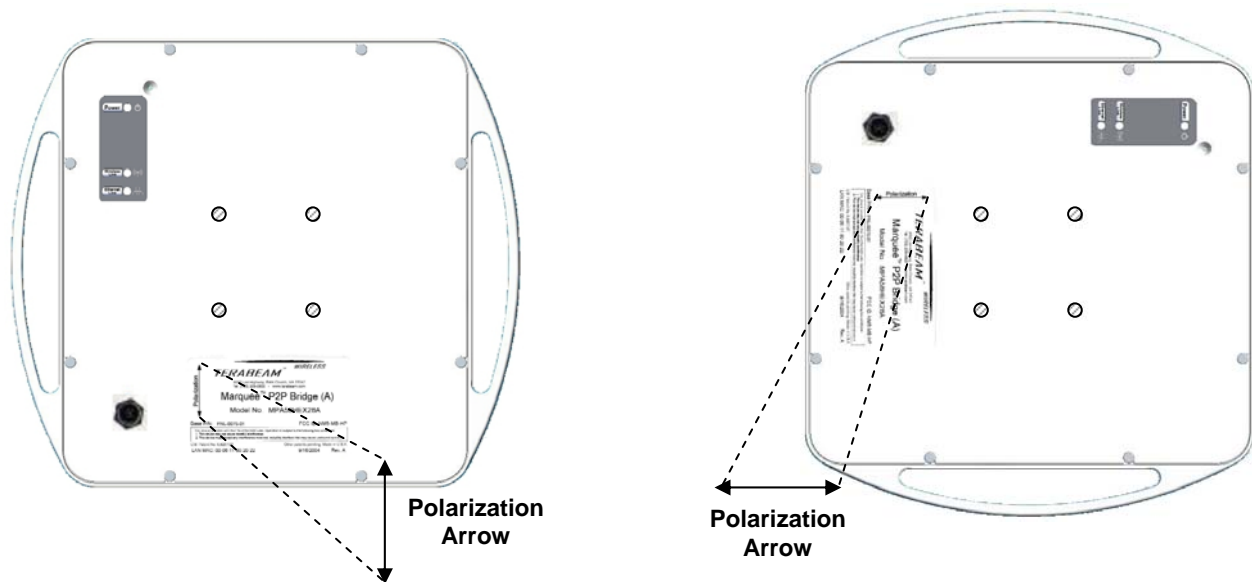


*If you are using a Marquee with an external antenna, the unit must be operated with a proper antenna, microwave load or terminator plugged into the N-type female jack on the back of the unit. Operating the Marquee with nothing connected to the jack may result in damage to the TX section of the unit which will not be covered by the factory warranty and will be a billable repair.*

**Figure 2.7 – Marquee EX With Attached Antenna Orientation**

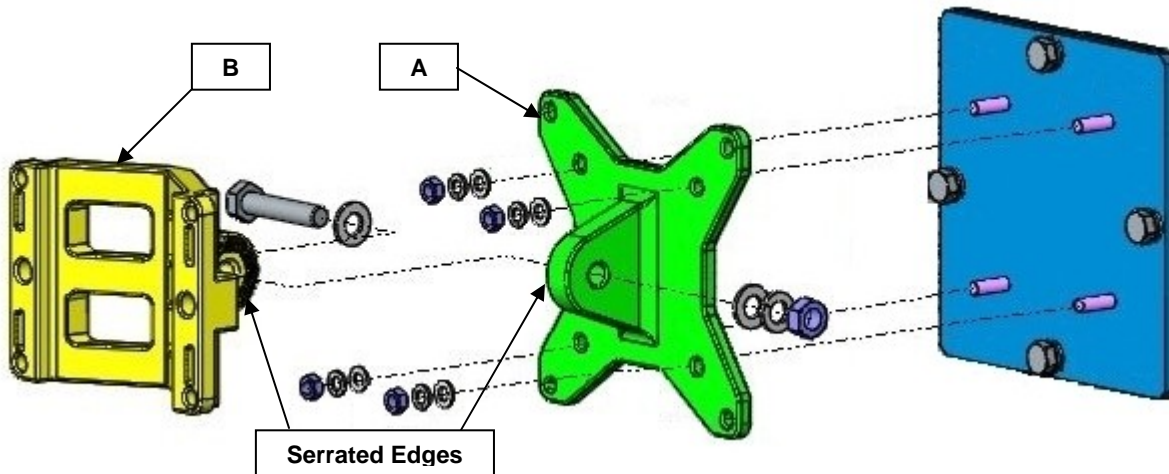
**(a) For Vertical Polarization**

**(b) For Horizontal Polarization**

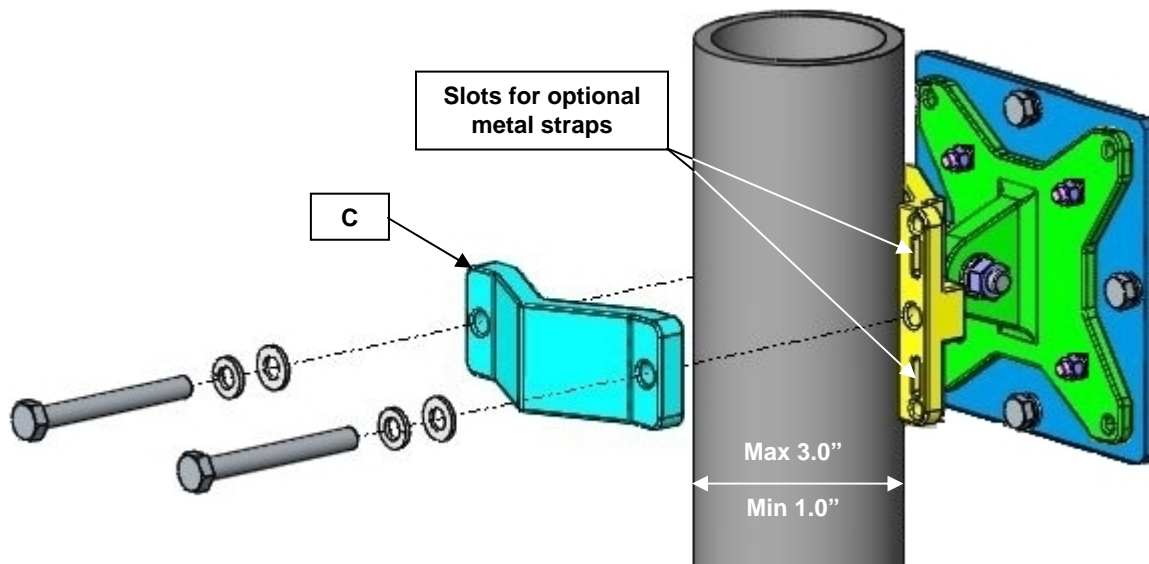


1. Fit the adaptor bracket (A) to the four studs protruding from the back of the Marquee EX unit, by aligning the four inner holes with the mounting studs on the back of the unit and securing to the unit using four nuts, lock washers, and flat washers, as shown in Figure 2.8. Tighten hardware (four places). **IMPORTANT:** Note the position of the serrated edge of bracket (A).
2. Attach the pole mounting bracket (B) to adaptor bracket (A) by using one M8x40 bolt and flat washer on one side, and nut, lock washer and flat washer on the other, as shown in Fig 2.8. Tighten hardware (one place). **IMPORTANT:** Ensure that the serrated edges on both brackets are facing each other.
3. Fasten the unit to the pole using pole clamp (C) and two M8x70 bolts, lock washers, and flat washers, as shown in Fig 2.9. Tighten hardware (two places). The pole mounting bracket (B) will accept pole diameters between 1.75" to 3" OD. You may attach the Marquee unit to smaller diameter poles, between 1" to 1.75" OD, by flipping over the pole clamp (C) so the convex part faces the pole and using two M8x40 bolts. The Marquee unit can also be mounted to larger pole diameters by discarding pole clamp (C) and replacing it with metal straps (not included) fastened through slots located on the pole mounting bracket (B).

**Figure 2.8 – Detail Showing Assembly of Pole Mounting Bracket to Marquee EX**



**Figure 2.9 – Attaching the Marquee EX Unit to the Pole**



Proceed to Section 2.7 – Cabling the Marquee (All Enclosures).

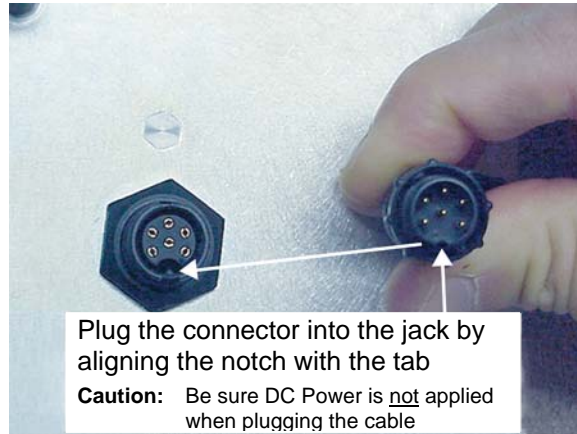
## 2.7 Cabling the Marquee (All Enclosures)

1. Ensuring that there is no DC power applied to the cable, plug the 6-pin N-male round connector of the outdoor Ethernet cable (ordered separately) into the rear jack of the unit, making sure the notch on the connector is correctly aligned with the tab on the jack as shown on Figure 2.10. Turn the round locking nut clockwise as you push in until it securely fastens onto the jack. **Please verify that the round connector is properly plugged into the rear jack of the antenna prior to connecting DC power** because it is possible to push it in the wrong way if enough force is used. If DC power is applied and the connector is not properly plugged, damage to the electronics of the unit or the connector itself may occur which will not be covered by the factory warranty.



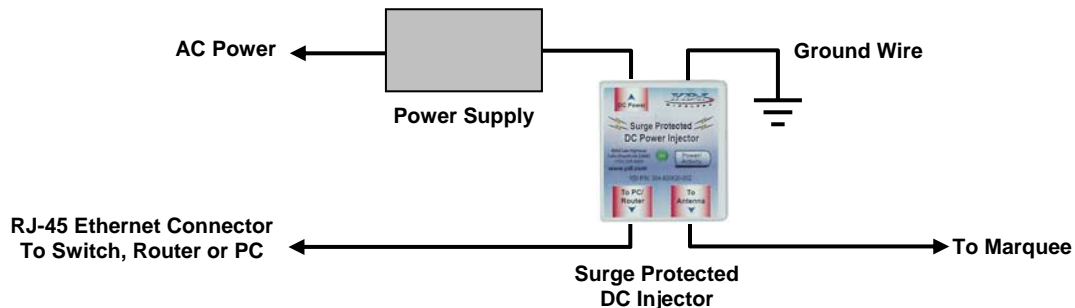
*If DC Power is applied while you are attempting to insert the round connector into the jack, it is possible that, as you rotate the plug in an effort to find the key, DC power pins will momentarily touch the Ethernet pins. **If this happens the Ethernet circuitry on the board will be damaged.** Also, do not apply excessive pressure when you insert the round connector or the pins will pop out. Any damage caused by this action will not be covered by the factory warranty and will be a billable repair.*

**Figure 2.10 – Plugging the Outdoor Ethernet Cable**



2. Attach the other end of the outdoor Ethernet cable to the Cat 5 DC Power Injector at port RJ-45 labeled “To Antenna.”
3. Connect the Ethernet cable labeled “To PC/Router” from the Cat 5 DC Power Injector into a regular port on your router, switch or hub. If you connect to a computer or PC, use a cross-over cable or adapter.
4. Perform an Earth ground connection to any of the rear bolts of the unit, the mounting brackets, or the mast (if metallic). For maximum protection, also connect the metal wire of the surge protected DC Injector to ground as shown on Figure 2.11.

**Figure 2.11 – Installation of the Terabeam Surge Protected DC Injector for Maximum Grounding Protection**



5. If you are using a Marquee unit with an external antenna, connect the antenna to the N-type female jack on the back of the unit.

6. Connect the barrel plug of the power supply to the “DC Power” jack on the Cat 5 DC Power Injector, then plug the Power Supply into an AC outlet. Check that the red Power LED on the Marquee turns on. If there is traffic over the wireless medium the green Wireless Link LED should be flashing. If the Ethernet port is active the green Ethernet Link LED should be flashing.
7. Install the Configurator program on a laptop or PC and configure your system (see Section 3). You are going to use the antenna alignment and link monitoring screen of the program to align the antennas.

## 2.8 Antenna Alignment

There are three possible antennas that you can use with the Marquee unit (refer to Table 1.1):

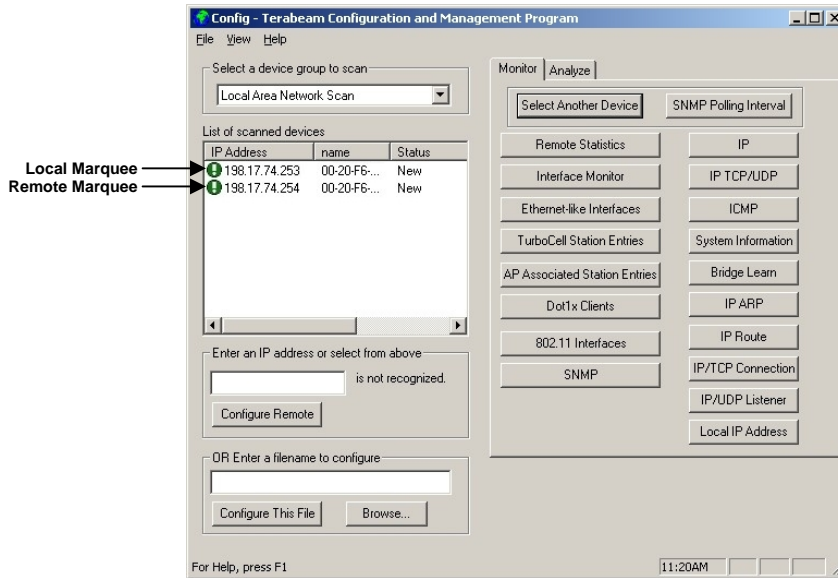
- A 23 dBi flat panel integrated to the FP enclosure
- A 23 dBi flat panel attached to the EX enclosure
- An external antenna
- The purpose of the following steps is to adjust the Line-of-Sight of the antennas in order to maximize the main lobe SNR (Signal-to-Noise Ratio) level. Regardless of the type of antenna that you are using, the procedure involves making an azimuth (horizontal) alignment and an elevation (vertical) alignment. The steps below pertain to integrated and attached antennas, but they are also applicable to external antennas as long as you follow the specific alignment instructions of the corresponding manufacturer. For a P-P configuration, you are going to align both antennas on each end.

**IMPORTANT:** During this process, all Marquee units must be at the same stage of the installation procedure and powered ON. It is assumed that you have configured your units (see Section 3) and that there is communication between the Configurator program and your Marquee units. Unless specifically noted, the term “antenna” is used to describe either of the three types.

1. Perform a coarse alignment of the antenna by using a compass heading so it is roughly “looking” at its remote partner.
2. Connect the near end Marquee unit to the laptop or PC where the Configurator program is installed by using a crossover Ethernet cable. Run the Configurator. Verify that the unit where you are locally connected to as well as its remote partner are both displayed on the Main Screen (Fig. 2.12).

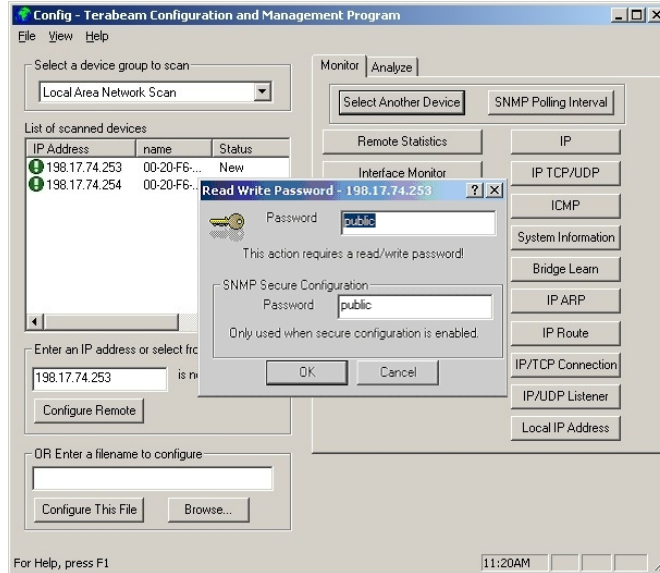
**Note:** If you cannot see the partner Marquee unit on the Main Screen, that probably means that your antenna is so misaligned that it cannot link to its partner. Perform a coarse alignment of both antennas by using a compass heading so they are “looking” at each other. Place the cursor anywhere in the *List of Scanned Devices* box and right-click the mouse. A *Re-scan local network* button will appear. Click on the button. If the partner Marquee still does not appear, repeat these steps until it is displayed.

**Figure 2.12 – Configurator Main Screen**



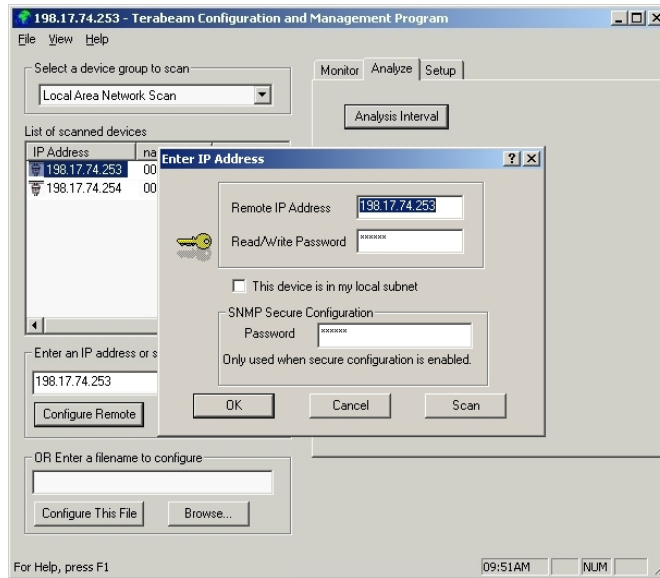
3. Login onto the local unit (Fig. 2.13). Click the **Analyze** tab, then click the **Wireless Link Test** button. The **Enter IP Address** window appears (Fig. 2.14). The IP address and the password should be correct since you just logged in. Click **OK**.

**Figure 2.13 – Login Screen**



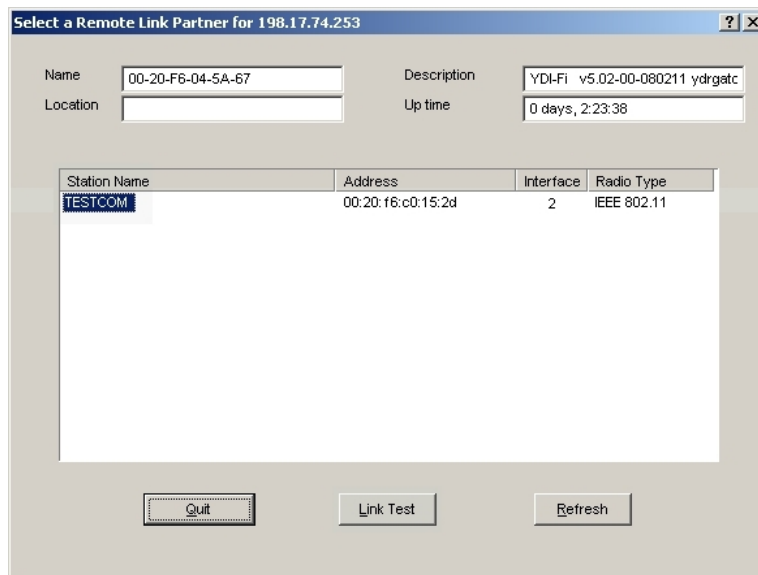


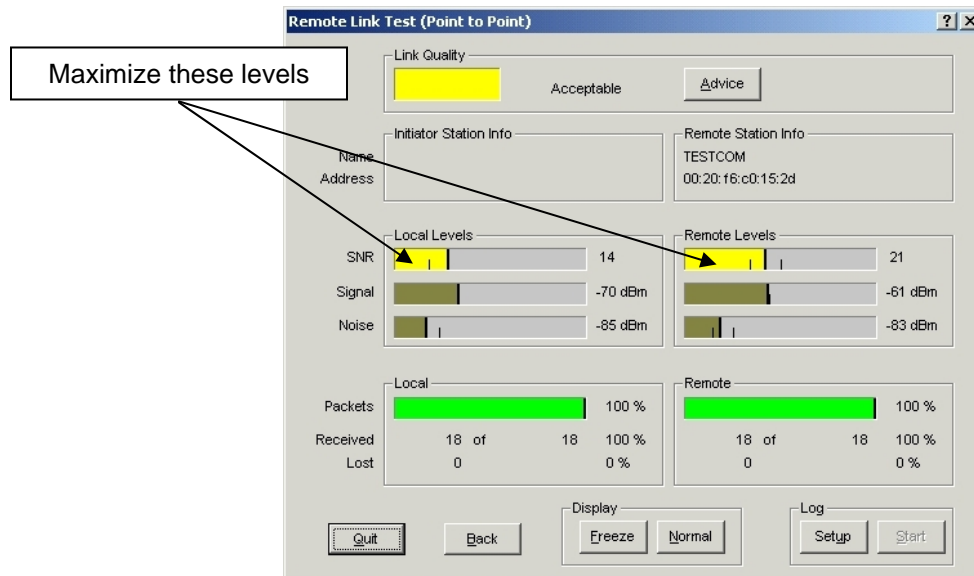
**Figure 2.14 – Enter IP Address Screen**



4. Click the **Wireless Link Test** button. Again, the **Enter IP Address** window appears. Click **OK**.
5. The **Select a Remote Link Partner** window appears (Figure 2.15). Verify that you have the partner Marquee unit displayed in the box, click on it and then click the **Link Test** button (or double-click the partner unit). The **Remote Test Link** window is shown (Figure 2.16). The main goal now is to peak the SNR levels at both ends of the link.

**Figure 2.15 – Select a Remote Link Partner Screen**

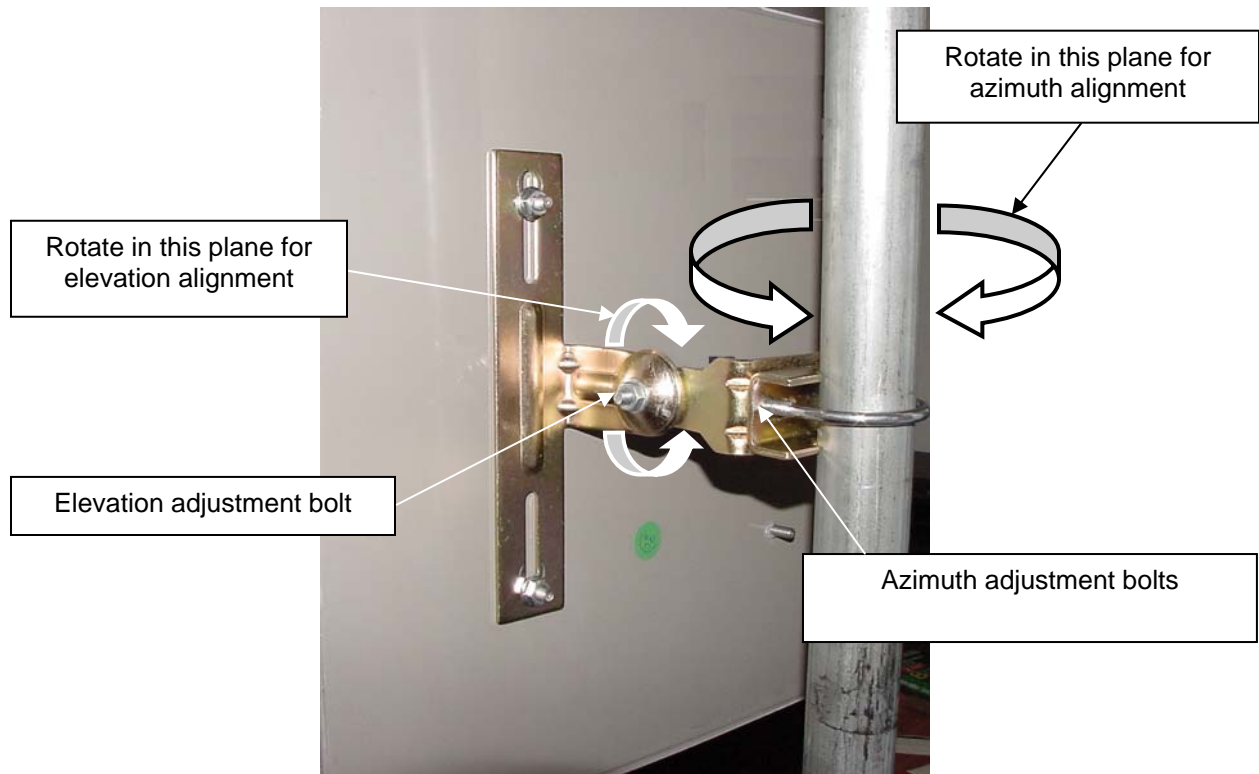


**Figure 2.16 – Remote Test Link Screen**

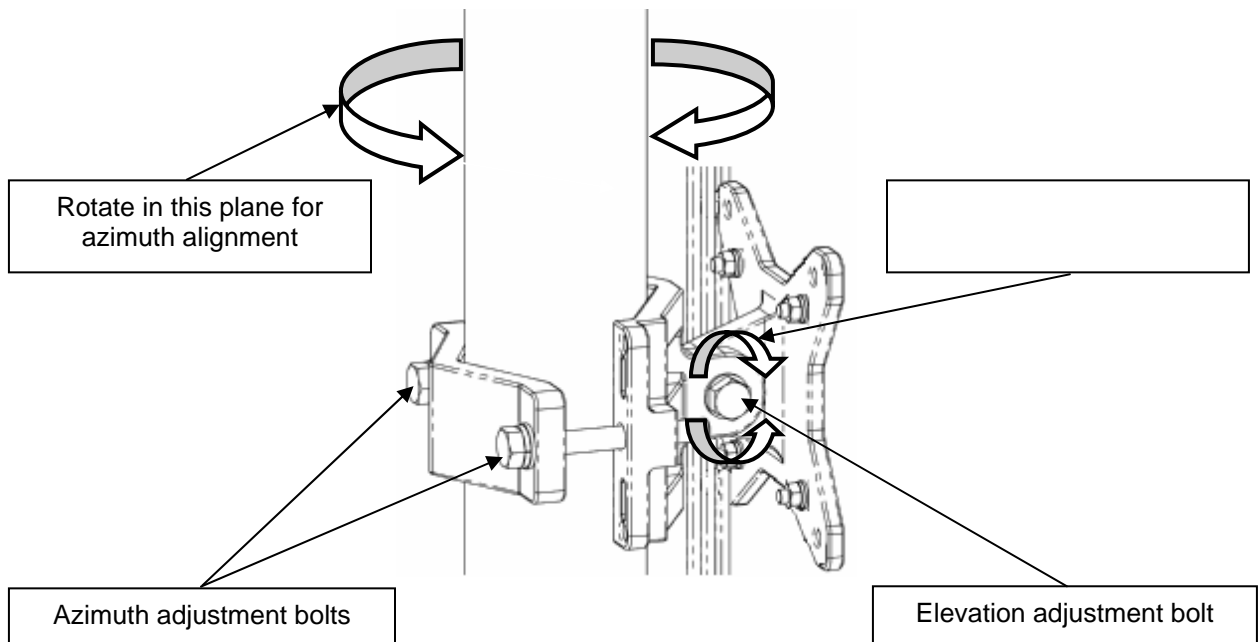
6. Using the Azimuth adjustment bolts (see Figure 2.17a or b), adjust the azimuth until the SNR readings for both ends of the link peak. Start with azimuth adjustment on the far end of the link first (if applicable). It is recommended that, in order to ensure the true maximum, you should adjust through the maximum SNR reading until the reading clearly drops and continues to drop to lower level side-lobes. Adjust back until the maximum is attained again. Then repeat for the near end of the link.
7. Using the Elevation adjustment bolt (see Figure 2.17a or b), adjust the elevation until the SNR readings for both ends of the link peak. Start with elevation adjustment on the far end of the link first (if applicable). It is recommended that, in order to ensure the true maximum, you should adjust through the maximum SNR reading until the reading clearly drops and continues to drop to lower level side-lobes. Adjust back until the maximum is again attained. Then repeat for the near end of the link.
8. Repeat steps 7 and 8 above to guarantee optimum alignment for maximum signal strength.
9. **CAUTION:** It is possible to obtain a false peak SNR reading from the signal of a side-lobe. Up to three different side-lobes on either side of the main lobe may give false peak alignment readings. For this reason, it is important that a wide sweep in both azimuth and elevation is made in order to identify these false peak SNR readings so to zero in on the true peak alignment reading due to the main antenna beam.
10. Tighten the two Azimuth adjustment bolts while observing the SNR reading to ensure the azimuth alignment does not change while tightening.
11. Tighten the Elevation adjustment bolt while observing the SNR reading to ensure the elevation alignment does not change while tightening.
12. **Test the Link.** Prior to placing the link in service for network traffic, the link should be tested using standard network procedures.



**Figure 2.17a – Final Line-of-Sight Adjustment for Signal Optimization (FP Enclosure)**



**Figure 2.17b – Final Line-of-Sight Adjustment for Signal Optimization (EX Enclosure)**



## Section 3 Configuration

### 3.1 Installing the Management Software

The Windows-based Configurator software can be installed on a laptop or PC running Windows 98, ME, 2000, NT, or XP. This software has a GUI (Graphical User Interface), which makes it easy to use. The program allows you to locally or remotely perform the following procedures:

- Display a list of units running on the network
- Display and edit the current configuration of the units
- Load and save configurations
- Update the firmware of the units

**Note:** Prior to installing a newer version of the Configurator program, you will need to remove any older versions:

1. Under the **Start** button on your desktop, go to **Settings**.
2. Click on **Control Panel**.
3. Choose **Add/Remove Programs**.
4. Select **Configurator**.
5. The software will uninstall itself.

**Windows Installation** – To install the Configurator in Windows, perform the following steps:

1. Insert the CD-ROM included in the Marquee kit into the appropriate drive of your computer. Using your Windows Explorer open the contents of the CD-ROM drive and select the following directory: **Management Software\Configurator**. Run the Configurator Installation program (the **.exe** file).
2. The InstallShield runs. Follow the onscreen instructions to install the Configurator. If you are installing the program for the first time, files are stored in the directory **\Program Files\Configurator**. If you are upgrading from a previous installation, your files will be stored in the directory where you last saved the Configurator files. The InstallShield also installs shortcuts to the Configurator on your desktop.
3. The **InstallShield Wizard Completed** screen will appear to indicate successful installation of the Configurator. Click **Finish** to complete the installation.

### 3.2 Using the Configurator

After completing the Configurator installation, you are ready to configure your Marquee system. The following steps provide a quick procedure to get you started. For more in-depth information about the Configurator and its commands, menus, and options please refer to the **Marquee Series Configuration Guide**, available as a pdf file on your CD ROM. Also, an online help is available by pressing **F1** or clicking **Help-> Index** from the main screen.

**IMPORTANT:** Your Marquee units must be on the same subnet as the computer where the Configurator program is installed, or have a routable IP address, in order to access them. If not, you will get a status of Offline for the units (see the Status column in Figure 3.1) even if the LEDs show activity. In order to be able to configure the units, change the IP address of your computer to a 198.17.74.x sub-net (the Marquee's default sub-net configured from factory). Once you have access to the units, you can assign a new IP address to them later by clicking on the **Setup** tab and **IP Host** button.

### 3.3 Configuring the Marquee

The Marquee is shipped from factory pre-configured for operation and with the proper transmit power settings. The units are set with the following default IP addresses:

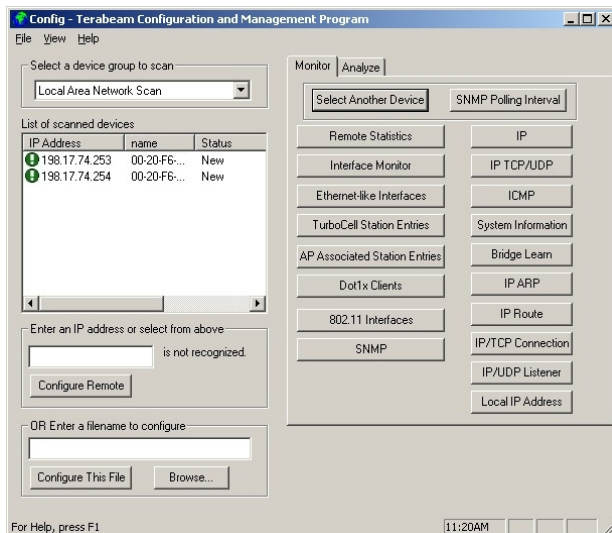
**Marquee Bridge P-P (2 each):**                    **198.17.74.251 and 198.17.74.252**

The default read/write password is *public*.

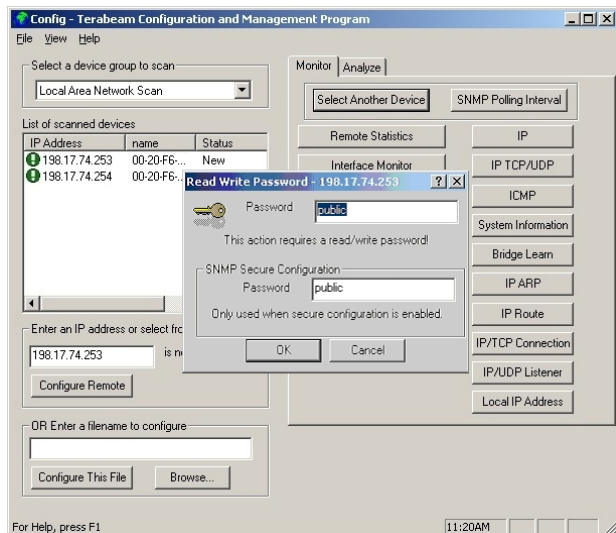
Some of the parameters that you may need to change are the following:

- IP addresses
  - Read/Write password
  - Radio frequency channel
1. Connect a crossover Ethernet cable from the Cat 5 DC Power Injector to your laptop or PC.
  2. Double-click the Configurator shortcut on your desktop. You may also open the directory where the Configurator program has been installed (the default is **\Program Files\Configurator**) and run the program **config.exe**.
  3. The Main Screen shown in Figure 3.1 appears. To scan for devices on the network, place the cursor anywhere in the *List of Scanned Devices* box and right-click the mouse. A *Re-scan local network* button will appear. Click on the button. A list of devices will appear.
  4. Click on the device you wish to configure. The selected device IP address will appear in the text box above the *Configure Remote* button (alternatively, you can enter here the IP address of the Marquee unit). Click this button.
  5. A **Read/Write Password** text box will appear (see Figure 3.2). The default password is *public*. Click the **OK** button. It is suggested that you change the password later, write it down and keep it in a safe place.

**Figure 3.1 – Configurator Main Screen**

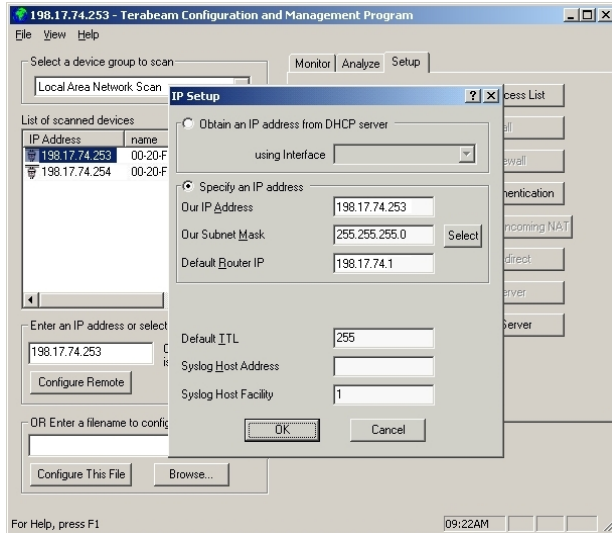


**Figure 3.2 – Login Screen**

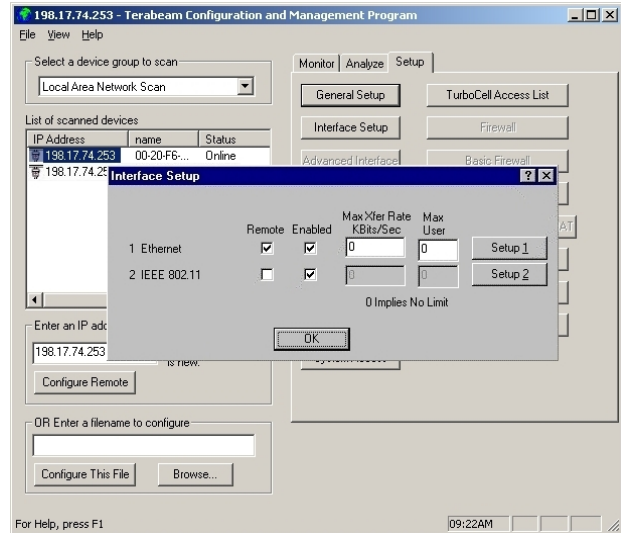


- After you login successfully, the **Setup** screen appears. Click on the **IP Host** button. The **IP Setup** screen appears (see Figure 3.3). Enter the IP Address, Subnet Mask, and Default Router IP Address. Click **OK**.
- Back to the Setup screen, click on the Interface Setup button. The corresponding screen appears (see Figure 3.4).

**Figure 3.3 – IP Setup Screen**

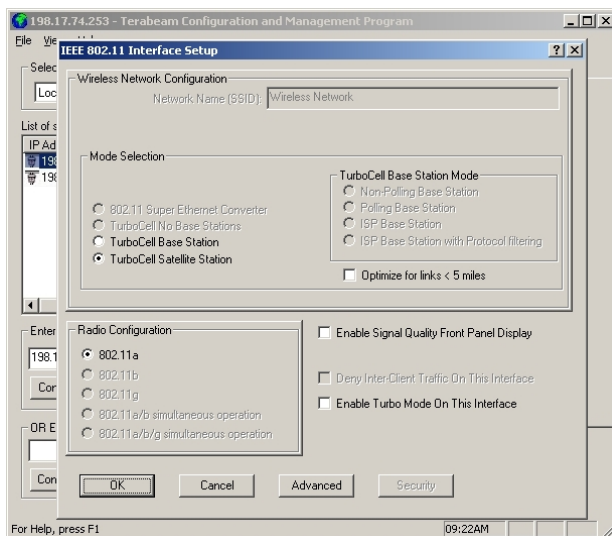


**Figure 3.4 – Interface Setup Screen**

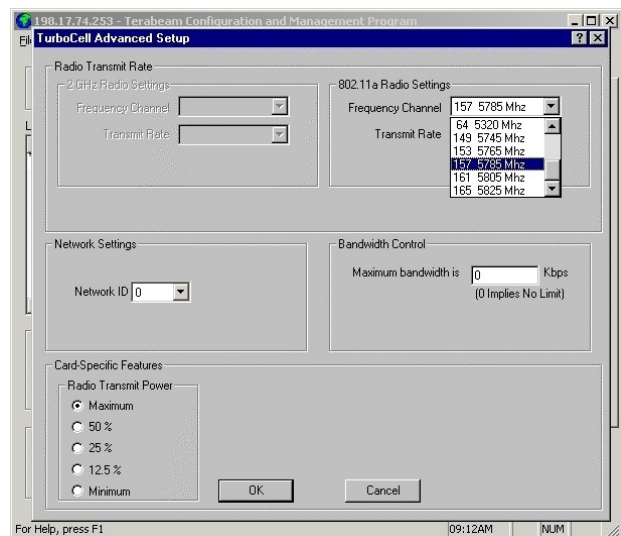


- Click on **Setup 2**. The **IEEE 802.11 Setup** screen appears (see Figure 3.5). Select the type of Station this Marquee is going to be. In a P-P configuration one unit must be Base and the other must be Remote (Satellite). Radio Configuration must be set to 802.11a. Leave the rest of the buttons unchanged.
- Click the **Advanced** button. The corresponding screen appears (see Figure 3.6). Select a Frequency Channel from the pull down menu box. Both units in a link must be configured with the same frequency value.

**Figure 3.5 – IEEE 802.11 Interface Setup Screen**

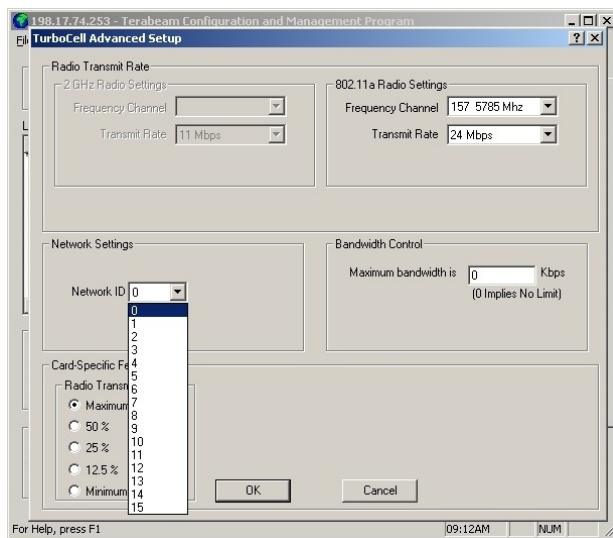


**Figure 3.6 – TurboCell Advanced Setup Screen**

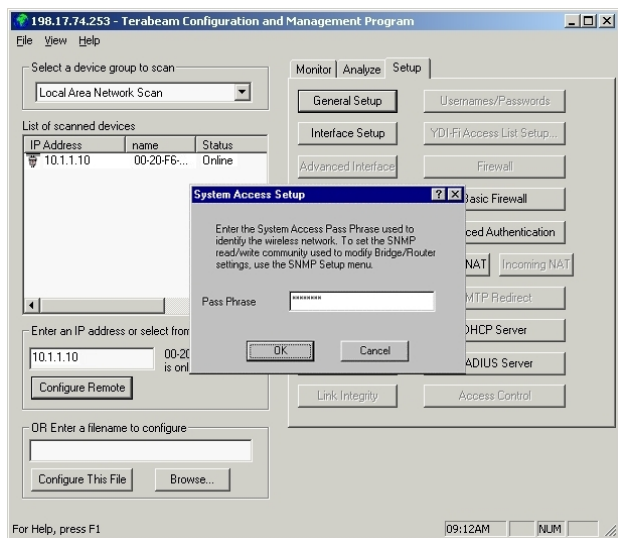


10. The Marquee is optimized for a transmit rate of 24 Mbps and the transmit power is preset from factory with the proper value.
11. Click the Network ID button. The corresponding screen appears (see Figure 3.7). Select a number from 0 through 15 to identify your network. Both units in a link must be configured with the same Network ID value.
12. Click **OK**. Click **OK** again.
13. Click the **System Access** button. The corresponding screen appears (see Figure 3.8). Enter a Pass Phrase to identify the wireless network. Both units in a link must be configured with the same Pass Phrase value. Click **OK**.

**Figure 3.7 – TurboCell Advanced Setup Screen Network ID**

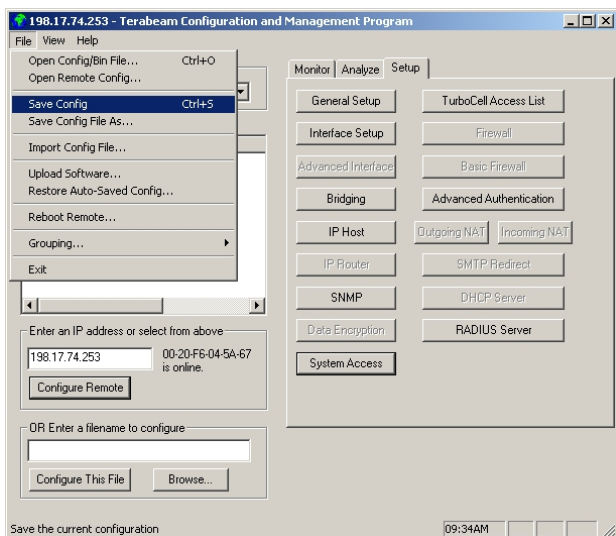


**Figure 3.8 – System Access Setup**



**Figure 3.9 – Save Configuration**

14. Go to **File** and click **Save Config**: this will save the new settings (see Fig. 3.9).
15. After the Marquee has finished saving its configuration, exit the Configurator program. The Marquee is ready to use. Refer to the **Marquee Series Configuration Guide**, available as a pdf file on your CD ROM, or the online help for complete instructions on setting up other features in the unit.



## Appendix A – Marquee Technical Specifications

**Table A.1 – Network Features**

<b>Network device type</b>	Ethernet bridge, IP router
<b>Media Access Control</b>	TurboCell Polling Protocol
<ul style="list-style-type: none"> <li>• Engineered for multipoint networks</li> <li>• Eliminates 802.11 hidden node</li> <li>• Adaptive Dynamic polling algorithm</li> <li>• SuperPacket Aggregation</li> <li>• Optimized for Internet traffic</li> </ul>	<ul style="list-style-type: none"> <li>• Yes</li> <li>• Yes</li> <li>• Yes</li> <li>• Yes</li> <li>• Yes</li> </ul>
<b>RADIUS Authentication</b>	Yes
<b>IP Routing</b>	RIP II
<b>Bridging</b>	Yes, 100% transparent (protocol independent)
<b>Bridge Filters</b>	MAC address, Protocol ID
<b>Spanning Tree</b>	Yes
<b>Automatic channel searching CPEs</b>	Yes
<b>Encryption</b>	DES (56-bit) Blowfish (128 bit) AES (128 Bit) [Upgradeable Q4 '04] Note: Encryption option lowers throughput since it is done in software.
<b>Watchdog Reboot Timer</b>	Yes
<b>DHCP Client &amp; Server</b>	Yes
<b>Static and Dynamic IP address</b>	Yes
<b>NAT</b>	Yes
<b>Roaming in the subnet</b>	Yes
<b>Bandwidth Management:</b>	Yes
<ul style="list-style-type: none"> <li>• Configurable for each remote location</li> <li>• Configurable for each interface</li> </ul>	<ul style="list-style-type: none"> <li>• Yes</li> <li>• Yes</li> </ul>
<b>SNMP Management</b>	Yes, GUI Management utility included
<b>SNMP Support</b>	MIB II and Private MIB
<b>Extensive Online Help</b>	Yes

**Table A.2 –Marquee FP Enclosure Specifications**

<b>Frequency</b>	5.725 – 5.850 GHz
<b>Return Loss</b>	12 dB, minimum
<b>Gain</b>	23 dBi
<b>E-plane Beamwidth</b>	7 degrees
<b>H-plane Beamwidth</b>	8.5 degrees
<b>Peak Sidelobe Level</b>	-10 dB

**Table A.3 – Physical & Environmental Features**

<b>Ethernet Interface (at POE injector)</b>	RJ-45, 10/100 Base-T
<b>Ethernet Cable Length</b>	300 ft maximum
<b>RF Interface (external antenna models)</b>	N-Female
<b>Operating Temperature Range</b>	-30°C to 60°C (-22°F to 140°F)
<b>Storage Temperature</b>	-40°C to 75°C (-40°F to 167°F)
<b>Operating Humidity</b>	0% to 100% (non-immersion rain)
<b>Altitude</b>	1000 ft (300 meters)
<b>Power Scheme</b>	Power over Ethernet (POE) Cat 5 DC Injector
<b>Power Supply</b>	110/220 VAC, 50-60 Hz
<b>Power Consumption</b>	16 W Max
<b>Current Draw</b>	0.5 A Max
<b>Input Voltage Required at Radio</b>	+36 to +57 VDC, nominal +48 VDC (supplied via POE)
<b>Dimensions (H x W x D)</b>	FP Enclosure: 15.3 x 15.3 x 1.13 in (389 x 389 x 29 mm) EX Enclosure: 12 x 14 x 3.25 in (305 x 356 x 83 mm)
<b>Weight</b>	FP Enclosure: 2.90 lbs (1.32 Kg) EX Enclosure: 9.65 lbs (4.38 Kg)
<b>Enclosure</b>	Outdoor, all-weather
<b>LED status indicators</b>	Power, Wireless Link, and Ethernet Link
<b>Min – Max Diameter of Mounting Pole</b>	For FP Enclosure: 0.75 – 1.5 in For EX Enclosure: 1.0 – 1.75 in or 1.75 – 3.0 in

**Table A.4 – Recommended External Antennas for the Marquee Series**

<b>Terabeam Part No.</b>	<b>Description</b>
<b>A5.3FP23-M</b>	Flat Panel, 1 ft, 23 dBi gain, 5.150 to 5.875 GHz
<b>A5.8FP28-M</b>	Flat Panel, 2 ft, 28 dBi gain, 5.150 to 5.875 GHz
<b>A5.8-2'-G</b>	Dish, 2 ft, 28.5 dBi gain, 5.250 to 5.850 GHz
<b>A5.8-2.5'-G</b>	Dish, 2.5 ft, 31.2 dBi gain, 5.250 to 5.850 GHz
<b>A5.8-4'-G</b>	Dish, 4 ft, 34.8 dBi gain, 5.250 to 5.850 GHz

**Table A.5 – RF Features**

	<b>5.8 GHz Frequency Specs</b>	<b>4.9 GHz Frequency Specs</b>
<b>Operational Frequency Band</b>	5725 – 5850 MHz	4940 – 4990 MHz
<b>Channels (user selectable)</b>	5 non-overlapping	Single channel: 4965 MHz with a bandwidth of 20 MHz
<b>Over-The-Air Data Rate</b>	User selectable up to 54 Mbps	User selectable up to 54 Mbps
<b>Throughput<sup>1</sup></b>	24 Mbps <sup>2</sup>	24 Mbps for single channel operation
<b>Modulation Scheme</b>	OFDM-QPSK	OFDM-QPSK
<b>Radio Operation</b>	Time Division Duplex (TDD)	Time Division Duplex (TDD)
<b>FCC Certified</b>	Yes	Yes
<b>Transmit Output Power</b>	+14 dBm for standard version +23 dBm for amplified version	+10 dBm for standard version +23 dBm for amplified version
<b>Receiver Sensitivity<sup>3</sup></b>	-74 dBm @ 36 Mbps -83 dBm @ 6 Mbps	-77 dBm @ 24 Mbps -84 dBm @ 12 Mbps -86 dBm @ 6 Mbps
<b>Maximum Receive Level</b>	-30 dBm	-30 dBm

<sup>1</sup> This is a typical figure. Actual throughput varies according to the specifications of the antenna used and the conditions of the terrain.

<sup>2</sup> The throughput of a MCL58HFP23I is 18 Mbps.

<sup>3</sup> Actual receiver sensitivity for individual products may vary based on manufacturing process and environmental variations.