

# **XR-2400**

## **User's Manual**

### **Zigbee UHF Transceiver**

\* This Service manual is subject to change according to improvement of XR-2400 Portable Radio without notice.

\* Version #1 (2011-08-14)

## Table of Contents

1. XR-2400 Features	-----	3
2. Components of XR-2400 Series Radio	-----	4
3. Appearance of XR-2400 Radio	-----	5
4. Basic Operation of XR-2400	-----	6
5. Operating XR-2400 Radio	-----	8
6. Operating Instructions of XR-2400 Radio	-----	11
7. FCC information	-----	12

## 1. XR-2400 Features

The features of XR-2400 are various as below. XR-2400 can be used under tough industrial environments as well as public places.

XR-2400 series have the following functions:

- 16 Channels are selectable.
- High-Quality Audio Output(Ø40 Speaker)
- PLL synthesizer type
- Signal Strength Meter
- Battery Status Indicator
- Advanced Speaker Protection technology
- DC+3.7V 1,800mAh rechargeable Li-ion employment quantity battery use

## 2. Components of XR-2400 Series Radio

\* Components could be changed by buyer request.



Figure 2-1) standard components of XR-2400 Radio

### 3. Appearance of XR-2400 Radio

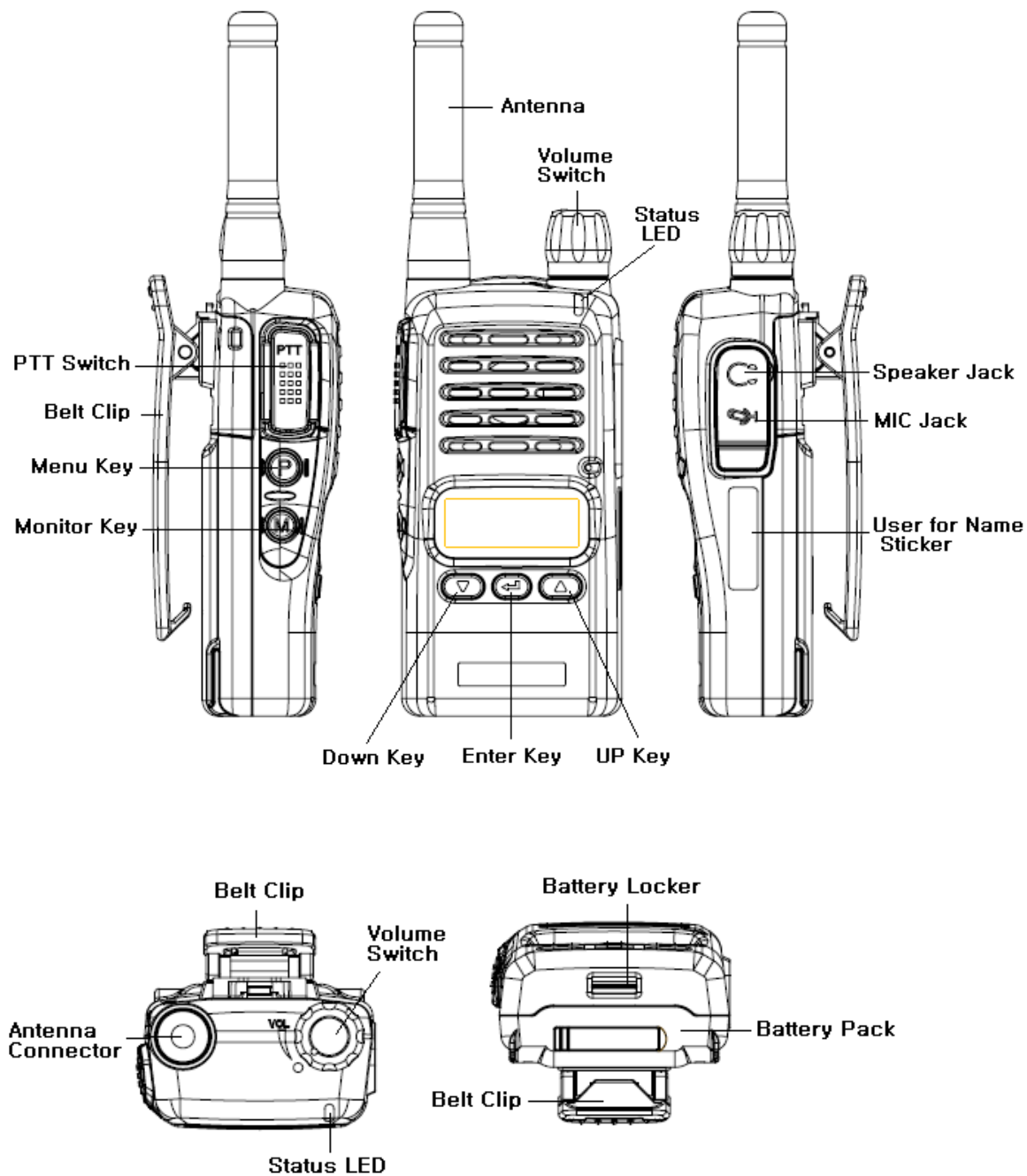

Figure 3-1) Appearance of XR-2400 Radio

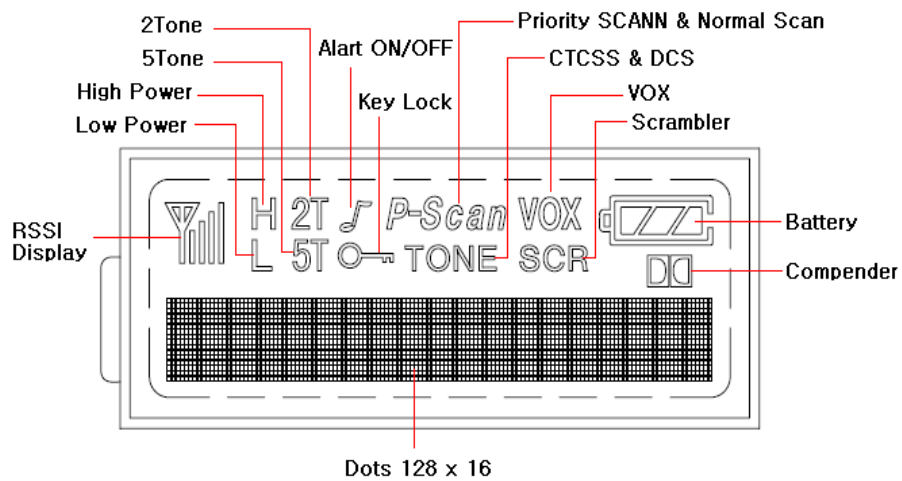

Figure 3-2) XR-2400 Series LCD Indication

## 4. Basic Operation of XR-2400

Pease read this manual carefully before using XR-2400 series Radio.

This manual contains important information about using Radio.

## 4.1 Installation and Removing the Battery

### 4.1.1 Installation of the battery

To install battery, slide up the battery towards the top of the radio until battery latch is locked.

### 4.1.2 Removing the Battery

- Slide the battery latch located on the bottom of radio to the open position as shown in Figure 4-2.
- The battery is removed by pressing it against and sliding it towards the bottom of the radio

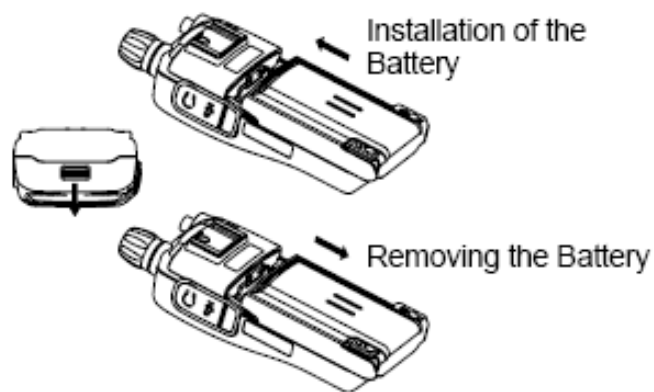

Figure 4-2) Installation and Removing the Battery

## 4.2 Installation and Removing the Belt Clip

- To attach belt clip to radio, align belt clip rails with the grooves in radio and slide the belt clip onto the mounting rails until it latches into place.
- To remove belt clip from radio, push up on tab of belt clip with flat bladed screwdriver and at the same time, slide the belt clip towards the top of Radio (Figure4-3).

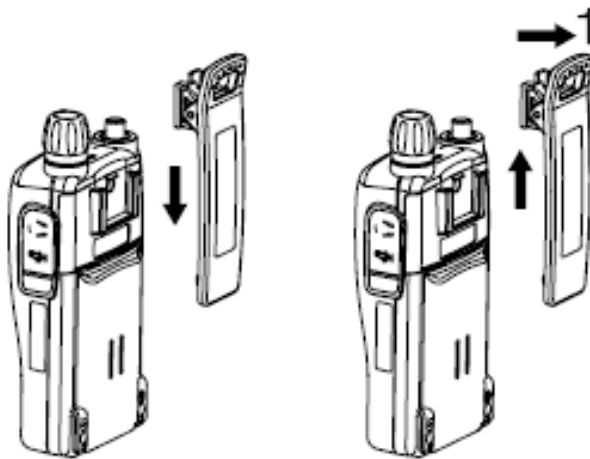

Figure 4-3) Installation and Removing the Belt Clip

### 4.3 Accessory connector

Accessory connector is used to connect external speaker/Mic, and headset, etc.  
Please close the cover when nothing is connected.



Figure 4-4) Accessory connector

## 5. Operating XR-2400 Radio

### 5.1 On/Off/Volume Control

Turns the radio on and off and adjusts audio volume level.

### 5.2 PTT Button(Push-To-Talk Button)

You can transmit by pressing PTT button. And then Red LED will be ON and your voice will be transmitted.

### 5.3 Channel Buttons(▼,▲)

Channel Buttons(▼,▲) have 2 functions as shown in following.

- ① Channel buttons(▼,▲) are to change channels.
- ② Channel buttons(▼,▲) are to select menu at menu mode.

### 5.4 Accessory Connector

The Accessory Connector is used when using an external speaker microphone or doing PC programming or making the Cloning or using as a Repeater.



## 5.5 RX /TX LED for Status

This LED is a lamp indicating the current status of the Radio and please refer to the below contents.

- ① RX : Red Lamp
- ② TX : Green Lamp
- ③ CTCSS, DCS Error : Green Blinks.
- ④ Low Battery: Red Blinks With "beep" sound.

## 5.6. Charging the Battery

### 5.6.1 Safety Notes

1) The radio of XR-2400 series receives power from high-performance Li-ion battery (XSB-1800). XSB-1800 Battery is safe of high performance and highly reliable, and could be charged very fast. XSB-1800 Battery has been designed suitably only for the charger of DC-100.

 Caution	The charging of the enclosed Radio on the other maker's charger will cause a damage on the battery and also, will cause a trouble on the Radio.
---	---

2) Please charge the battery before using the radio for best performance and safety.

1) When you charge the battery that is installed in the Radio, please turn off the radio first to charge the battery.

 Caution	The continuous rapid discharge (for example, when making a short circuit on the '+' terminal of battery by a metal substance) may make a fatal defect and the battery can be exploded. Also, it can cause a fire.
--	---

4) Using the correct battery will improve the efficiency and safety.

### 5.6.2 The Time of Charging

Low battery voltage will make the radio less coverage and also make the performance worse. Please charge the battery in case of following:

- ① When you think performance of the radio becomes lower
- ② When the red lamp on RX/TX Led blinks (every 0.5 second) during transmission or reception
- ③ When the battery icon blinks
- 4) When "beep" sound is generated while the radio is in use.



Figure 5-1) Charging the Battery

### 5.6.3 How to Charge

- 1) Plug the DC-100 charger into the electricity power outlet.
- 2) When charging the Radio with the battery installed, please turn off the power of the Radio and place the Radio on the charger (The charger has a slide slot.).
- 3) After completion of the charging, the green LED on the charger will light. However, please continue the charging for 30 more minutes for the complete full charge.

status	LED indication	status	LED indication
During charging	Red LED lights.	Detecting error	Red LED is off.
After charging	Green LED lights.	When charging	Green LED lights

### 5.6.4 Charger (DC-100)

The DC-100 charger is designed to charge only the Li-ion battery enclosed in this Radio.



Figure 5-2) DC-100 Charger

## Specifications of DC-100 Charger :

- Adaptor Input Voltage : AC 100 ~ 240V
- Adaptor Output Voltage : DC 5V
- Battery : XSB-1800
- Quick Changing Time : In 3 Hours and half
- Operation Temperature : 0°C ~ +50°C
- Size : 76(W)x85(D)x37(H)m/m
- Charging Current : 750mA (Fast charging)

## 6. Operating Instructions of XR-2400 Radio

### 6.1 Power On/Off

Turn Power switch clockwise. As soon as power is supplied, the backlight will be turned on. If the user had set up the user ID, it will be displayed on the LCD and radio will enter into the latest state as a signal sound is generated.

 Caution	When turning (power) on the radio by pressing a button on it, the radio may enter into a special modes in which transmission and reception is impossible. Please don't turn on the radio by above way.
--	--

### 6.2 Transmission Method

For transmission, press PTT button on the left side of the radio. As soon as the user presses keys according to the setting, DTMF ID will be transmitted, and during this time, voice communication will be interrupted for several seconds. Then, red LEDs for transmission and reception will be turned on. It is recommended to talk 5 ~ 10cm away from the microphone for the best voice communication.

☞ Note: If the user makes transmission for more than a certain time while BCLO or TOT feature is on, transmission will be forcefully disconnected for other users.

 Caution	If present channel is TX Inhibited by pc program, TX will not be worked. (By PC Program, it could be set)
--	--

### 6.3 Reception Method

The user should not press PTT button during the reception. The user can adjust the volume by Volume switch, and during reception, the green LED will be turned on. Depending on conditions

of the transmitting radio,

## 6.4 Changing Channels

Channel buttons (▼,▲) are to change channels. Press Up button (▲). Then, "beep" sound will be generated and the channel number will be increased. Or press Down button (▼) to decrease the channel. If the user presses Up or Down button while only one channel is set, the channel will not be changed and a different sound from "beep" will be generated. For fast increase or decrease channel numbers, press Channel buttons (▼,▲) for a while. In this case, however, "beep" sound will not be generated.

## 7. FCC Information to User

This equipment has been tested and found to comply with the limits for a Class B digital device, pursuant to Part 15 of the FCC Rules. These limits are designed to provide reasonable protection against harmful interference in a residential installation. This equipment generates, uses and can radiate radio frequency energy and, if not installed and used in accordance with the instructions, may cause harmful interference to radio communications. However, there is no guarantee that interference will not occur in a particular installation. If this equipment does cause harmful interference to radio or television reception, which can be determined by turning the equipment off and on, the user is encouraged to try to correct the interference by one of the following measures:

- Reorient or relocate the receiving antenna.
- Increase the separation between the equipment and receiver.
- Connect the equipment into an outlet on a circuit different from that to which the receiver is connected.
- Consult the dealer or an experienced radio/TV technician for help.

### Caution

Modifications not expressly approved by the party responsible for compliance could void the user's authority to operate the equipment.

## 8. Safety Notes

### Body-worn Operation

This device has been tested for body-worn operation and meets FCC RF exposure guidelines. Body-worn operation is restricted to accessories that maintain a minimum of 1.5cm separation to the body and do not contain metallic components. Use of any other body-worn accessories may not compliance with FCC RF exposure guidelines.

## 9. WARNING

This transceiver generates RF EME while transmitting. RF EME(Radio Frequency Electric & Magnetic Energy)has the potential to cause slight thermal, or heating effects to any part of your body less than the recommended distance from this radio transmitter's antenna. RF energy exposure is determined primarily by the distance to and the power of the transmitting device. In general, RF exposure is minimized when the lowest possible power is used or transmission time is kept to the minimum required for consistent communications, and the greatest distance possible from the antenna to the body is maintain. The transceiver has been designed for and is classified for Occupational use only. Occupational/controlled exposure limits are applicable to situations in which persons are exposed to RF energy as a consequence of their employment, and such persons have been made aware of the potential for exposure and can exercise control over their exposure. This means you can use the transceiver only if you are aware of the hazards of operating a transceiver and are familiar in ways to minimize these hazards. This transceiver is not intended for use by the general public in uncontrolled environments. Uncontrolled environment exposure limits are applicable to situations in which the general public may be exposed to RF energy ,or in which the persons who are exposed as a consequence of their employment may not be fully aware of the potential for exposure or cannot exercise control over their exposure

The following list provides you with the information required to ensure that you are aware of RF exposure and of how to operate this transceiver so that the FCC RF exposure limitations are not exceeded.

- > While transmitting(holding the PTT switch), always keep the antenna at least 2.5cm (1 inches) from your body or face ,as well as from any bystanders
- > Do not transmit for more than 50% of the total transceiver use time; transmitting over 50% of the total use time may exceed the limits in accordance to the FCC RF exposure requirements. Nominal transceiver operation is 5% transmission time,5% reception time, and 90% stand-by time
- > Use only the specified antenna for this transceiver; this may be either the antenna provided with the transceiver or another antenna authorized by Yeonwha M tech. Use only Yeonwha M tech authorized accessories (antennas, battery packs, belt clips)