

YAESU

The radio

C4FM FDMA 144/430 MHz

DUAL BAND DIGITAL TRANSCEIVER

FTM-400DR

OPERATING MANUAL

YAESU MUSEN CO., LTD.

Tennozu Parkside Building
2-5-8 Higashi-Shinagawa, Shinagawa-ku, Tokyo 140-0002 Japan

YAESU USA

6125 Phyllis Drive, Cypress, CA 90630, U.S.A.

YAESU UK LTD.

Unit 12, Sun Valley Business Park, Winnall Close
Winchester, Hampshire, SO23 0LB, U.K.

YAESU HK LTD.

Unit 1306-1308, 13F., Millennium City 2, 378 Kwun Tong Road,
Kwun Tong, Kowloon, Hong Kong

Before Using This Equipment	3	Programmable Memory Scan (PMS).....	37
Safety Precautions (Be Sure to Read)	3	Writing into a Programmable Memory.....	37
Before Transmitting Radio Waves	8	Performing Programmable Memory Scan.....	39
Accessory and Option	9	Useful Functions	41
Attaching Accessory Items	10	Dual Reception (DW) Functions	41
Connecting the Panel Screen to the Main Unit....	10	Dial Dual Reception	
Connect the accessory microphone (MH-48).....	10	VFO mode → Home channel	41
Setting up the Panel Screen with the accessory		Memory Dual Reception	
bracket.....	11	Memory channel → Home Channel	42
Names for various parts, Functional Parts and their		Using the DTMF Function.....	42
Functions.....	12	Sending the Registered DTMF Code	43
Description for Panel Screen	12	Sending a DTMF Code Manually	44
Description about the Screen.....	13	Communicating with a Specific Remote Station 45	
Description of Microphone (MH-48).....	16	Using the Tone Squelch Function.....	45
Using the microSD Memory Card.....	17	Selecting a Tone Frequency	46
Usable microSD memory cards.....	17	Searching for the Frequency of the Tone Squelch	
Precautions for when using a microSD memory		Used by the Remote Station.....	46
card	18	Selecting a DCS Code.....	47
Installing/removing microSD memory card	18	Searching for the Frequency of the DCS Used by	
Formatting the microSD Memory Card	19	the Remote Station	47
Basic Operation	20	Notification of Call from a Remote Station by the	
Communication.....	20	Bell.....	48
Changing the Beep Sound.....	20	Calling Only a Specific Station New Pager	
Using the Timer Function.....	21	Function.....	48
The ALTITUDE function for measuring altitude....	22	Flow of Operation to Use the Pager Function.....	48
Locking Keys and Switches	22	Setting the Code of Your Station.....	49
Changing Transmission Output.....	24	Turning on the New Pager Function	49
Adjusting Microphone Sensitivity (MIC GAIN).....	24	Calling a Specific Station	50
Other Settings.....	25	Being Called by the Remote Station (Standby	
Adjusting Time	25	Operation).....	51
Muting Sounds.....	26	Functions Used as Needed	52
Adjusting Squelch Level.....	26	Setup Menu	52
Manually switching frequency steps	27	Settings for the Setup Menu	52
Resetting applied settings.....	27	Setup Menu Operations List	52
Repeater Operation	28	Apply settings to contents displayed on screen ..	59
Repeater Operation.....	28	Setting the Background Color of the Screen	60
Communicating Via the Repeater	28	Setting the Frequency Width for Band Scope.....	60
Communicating Via the Repeater Using a Tone		Adjusting the LCD Backlight Brightness Level.....	61
Signal Other Than the 88.5Hz Tone Signal.....	28	Adjusting LCD Contrast	61
Using Memory	30	Switching between Time and Voltage display.....	62
Wide variety of Memory Functions	30	Adjusting volume respectively to A/B Bands.....	62
Registering to Memory.....	30	Setting the Display Method for Memory	
Split Memory.....	31	Channels.....	63
Recalling a Memory Channel.....	31	Setting the Squelch Type for transmission.....	63
Recalling the Home Channel.....	32	Setting the display format for the Clock Function	64
Returning to the Previous Frequency.....	32	Setting the Time Zone.....	65
Deleting Memory.....	32	Setting the Automatic Repeater Shift.....	65
Changing the display method of Memory Tags.		Setting the Clock Shift of the Microcomputer.....	66
.....	33	Setting the Program Keys on the Microphone	66
Scanning Function	34	Setting the Bandwidth to Scope.....	67
Using the Scanning Function.....	34	Setting the unit of measurement to be displayed.	67
VFO Scan	34	Automatically Turning Off the Power	
Canceling Scanning	34	APO Function.....	68
Setting a Reception Method When Scanning		Restricting the Continuous Transmission Time	
Stops	34	TOT Function	68
Memory Scanning.....	35	Setting PIN Code for a BLUETOOTH headset	69
		Selecting Datum for GPS function.....	69

Contents

Setting the GPS Device to Use.....	70
Setting Time for Accessing GPS.....	70
Communicating by crossing A Band and B band frequencies	71
Setting USB Camera to Use.	71
Setting operations of BLUETOOTH Headset to Use.....	72
Setting Operations of the Voice Announcement Function	73
Writing Group ID to microSD Memory Card.....	74
Registering Preset	75
Recalling the Registered Preset.	75
Deleting Memory Channels.....	76
Sorting Registered Memory Channels in Order. .	76
Deleting Settings Configured for APRS Function.....	77
The Clone Function For copying settings to another FTM-400DR.....	77
FTM-400DR Specifications	79

Safety Precautions (Be Sure to Read)

Be sure to read the safety precautions to use this product safely.

We are not liable for failures and other problems caused due to misuse or use of this product by you or a third party as well as the damages caused through use of this product by you or a third party except in the case where we are ordered to pay for damages under the laws.

Types and Meanings of Symbols



DANGER

Indicates an imminently hazardous situation which, if not avoided, could result in death or serious injury.



WARNING

Indicates a potentially hazardous situation which, if not avoided, could result in death or serious injury.



CAUTION

Indicates a potentially hazardous situation which, if not avoided, may result in minor or moderate injury or only property damage.

Types and Meanings of Legends



Indicates a prohibited item not to be done in order to use this product safely. For example,  indicates that the product should not be disassembled.



Indicates an obliged item to be done in order to use this product safely. For example,  indicates that the power plug should be removed.

Before Using This Equipment

||||| **DANGER** |||||



Do not use this product in “an area where use of it is prohibited”, e.g., inside the hospital, airplane, or train.”

This product can affect electronic or medical devices.



Do not use this product while riding a bicycle or driving a car. Accidents can result.

Be sure to stop the bicycle or car at a safe place before using this product.



Those who are carrying a medical device such as a cardiac pacemaker should not perform transmission near it. When performing transmission, use an external antenna and keep away from the external antenna as far as possible.

The radio wave emitted from this product can cause the medical device to malfunction and result in an accident.



Do not use this product or the battery charger in a place where inflammable gas is generated.

A fire or explosion can occur.

Safety Precautions (Be Sure to Read)



Do not perform transmission in a crowded place for the safety of the persons carrying a medical device such as a cardiac pacemaker.

The radio wave emitted from this product can cause the medical device to malfunction and result in an accident.



Do not touch the liquid leaking from the battery pack with bare hands.

The liquid that has stuck to your skin or entered in your eye can cause chemical burn. In such a case, consult the doctor immediately.



Do not solder or short-circuit the terminal of the battery pack.

A fire, leak, overheating, explosion, or ignition can result.

Do not carry the battery pack together with a necklace or hair pin. A short circuit can result.



If it starts thundering when the external antenna is used, immediately turn off this product and disconnect the external antenna from it.

A fire, electrical shock, failure can result.



WANING



Do not use this product at a voltage other than the specified power supply voltage.

A fire or electric shock can result.



Do not use the battery pack for any model other than the specified mode.

A fire, leak, overheating, explosion, or ignition can result.



This product has a waterproof structure and conforms to "IPX5" when the included antenna and battery pack are installed and rubber caps are securely attached to the MIC/SP jack, EXTDC IN jack, DATA terminal, and micro SD slot. If this product gets wet, wipe it with a dry cloth, etc. without leaving it as it is.

Leaving this product in a wet condition can degrade its performance, shorten its life, or cause a failure or electrical shock.



Do not perform transmission for a long period.

The main body can overheat, resulting in a failure or burn.



Do not disassemble or make any alteration to this product.

An injury, electric shock, or failure can result.



Do not handle the battery pack or charger with wet hands. Do not insert or remove the power plug with wet hands.

An injury, leak, fire, or failure can result.



If smoke or strange odor is emitted from the main body, battery pack, or battery charger, immediately turn off this product, remove the battery pack, and remove the power plug from the outlet.

A fire, leak, overheating, damage, ignition, or failure can result. Contact the shop from which you purchased this product or our Amateur Customer Support.



Do not use the battery pack which is externally damaged or deformed.

A fire, leak, hating, explosion, or ignition can result.



Do not use any battery charger which is not specified by us.

A fire or failure can result.



Keep the terminals of the battery pack clean.

If stained, a fire, leak, overheating, explosion, or ignition can result.

Safety Precautions (Be Sure to Read)



If charging of the battery pack cannot be completed after lapse of the specified time, immediately remove the power plug of the battery charger from the outlet.

A fire, leak, overheating, explosion, or ignition can result.

|||||  **CAUTION** |||||



Do not dangle or throw this product by holding its antenna.

This product can hit and injure someone. In addition, doing so can result in a main body failure or damage.



Do not use this product in a crowded place.

The antenna can hit someone, resulting in an injury.



Do not place this product in a place subject to direct sunlight or near a heater.

This product can deform or discolor.



Do not place this product in a humid or dusty place.

A fire or failure can result.



During transmission, keep the antenna away from you as far as possible.

Long-time exposure to electromagnetic waves can have a negative impact on your health.



Do not clean the case with thinner or benzene.

Use a soft, dry cloth to clean the case.



If you do not use this product for a long period, turn it off and remove the battery pack for safety.



Do not give a strong shock to or throw this product.

A failure can result.



Keep magnetic cards and video tape away from this product.

The data recorded on cash cards or video tape can be erased.



Do not use the earpiece microphone, earphones, or headphones at an extremely high volume level.

Hearing impairment can result.



Keep this product out of reach of children.

An injury, etc. can result.



Install the hand strap and belt click securely.

If they are installed improperly, they can fall down, resulting in an injury or damage.



Do not place a heavy thing on the power cord of the battery charger.

The battery cord can be damaged, resulting in a fire or electric shock.



Do not use the included battery charger to charge any battery pack which is not specified by us.

A fire can result.



Do not perform transmission near the TV or radio.

Radio disturbance can occur in this product, TV, or radio.



Do not use any products other than the options specified by us.

A failure can result.



When the battery charger is not in use, remove its power plug from the outlet

Before Using This Equipment

Safety Precautions (Be Sure to Read)

Charge the battery pack within the temperature range from 5°C to 35°C.



Charging the battery pack outside this temperature range can cause leak, overheating, decrease in performance, or reduction in service life can result.

When unplugging the power cord of the battery charger, be sure to hold the power plug.



Pulling the power cord can damage it and cause a fire or electronic shock.



Before discarding the worn battery pack, affix tape or the like to its terminals.

When using this product in a hybrid or fuel-saving car, be sure to check with the automobile manufacturer if the it can be used in that car.



Noise generated by an onboard electrical device (inverter, etc.) can disable normal reception by this product.

Safety Precautions (Be Sure to Read)

About Waterproofing Feature Conforming to IPX5

When the included antenna and battery pack are installed and the MIC/SP jack, EXT DC IN jack, DATA terminal, and micro SD slot are securely covered with rubber caps, this product can withstand continuous 30-minute immersion in water at depth of 1 m. To ensure this waterproofing feature, be sure to check the following points before use.

○ **Check for damages, deterioration, and dirt.**

Antenna rubber, key switch rubber, MIC/SP jack, EXT DC IN jack, DATA terminal, micro SD slot rubber cap, and battery pack joint.

○ **Cleaning**

When this product is contaminated with seawater, sand, or dirt, rinse with fresh water, and then wipe with a dry cloth immediately.

○ **Recommended maintenance interval**

It is recommended that you ask for maintenance of this product when one year has passed since purchase or previous maintenance or when any damage or deterioration is found. Note that the maintenance service is subject to fees.

○ **Do not immerse this product in the following liquids:**

Sea, pool, hot spring, water containing soap, detergent, or bath additive, alcohol, or chemicals

○ **Do not leave this product for a long time in the following places:**

Bathroom, kitchen, or humid place

○ **Other precautions**

Since this product is not totally waterproof, it cannot be used in water.

Before Transmitting Radio Waves

If you are informed that the radio waves emitted from your amateur station are interfering with reception by the TV, radio, etc., of a neighbor, you should stop emitting the radio waves and check whether any problem of interference and its degree if it exists.

Accessory and Option

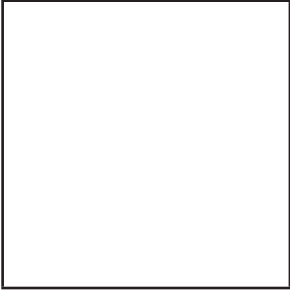

xxxx

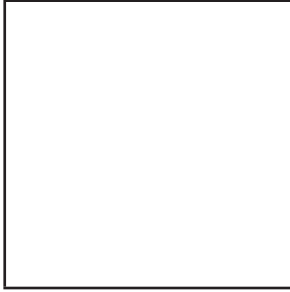

xxxx

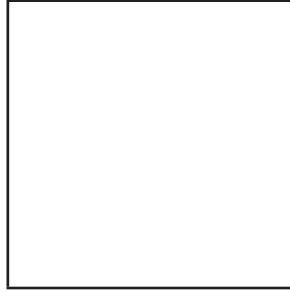

xxxx

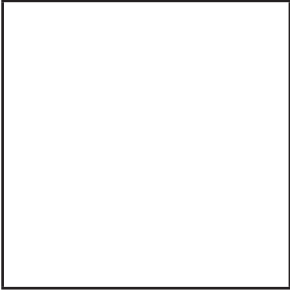

xxxx

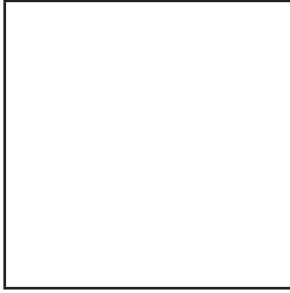

xxxx

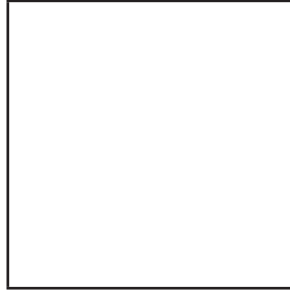

xxxx

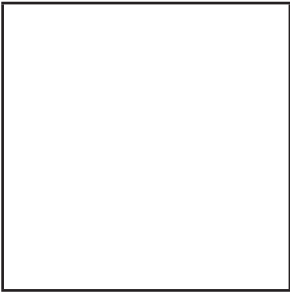

xxxx

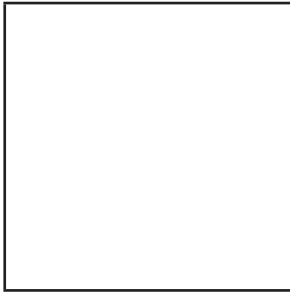

xxxx

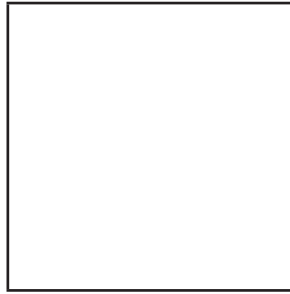

xxxx

Before Using This Equipment

Attaching Accessory Items

Connecting the Panel Screen to the Main Unit

Connect the Panel to the Main Unit.

Precaution

- Make sure to turn off the Main Unit when connecting the Panel Screen to the Main Unit.

- 1 Connect the accessory cable to the Main Unit.

Connect the cable to the [CONTROL] port of the Main Unit.

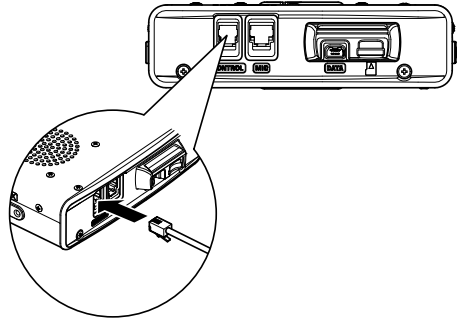

- 2 Connect the cable to the Panel Screen.

Connect the cable to the [CONTROL] port of the Panel Screen.

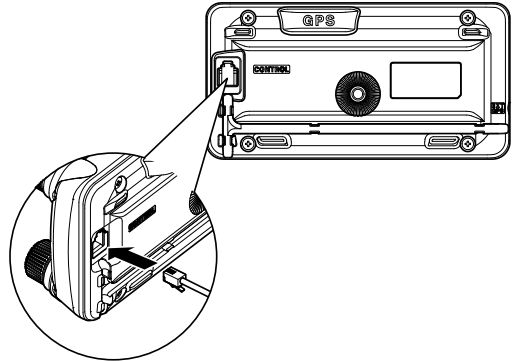

Connect the accessory microphone (MH-48).

- 1 Insert the microphone (MH-48) into the MIC port of the Main Unit.

As shown in the image on the right, connect the accessory microphone (MH-48) to the MIC port of the Main Unit.

Reference • When removing the microphone, pull it out while pressing [PUSH ▼].

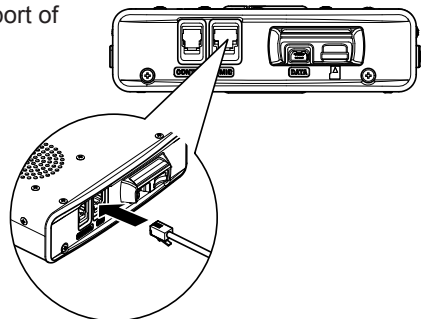

Attaching Accessory Items

Setting up the Panel Screen with the accessory bracket.

Set the Panel Screen up with the accessory bracket.

Precaution

- The bracket can be shaped by hand to fit where the Panel Screen is to be set. Be careful not to injure yourself when manipulating the bracket into the desired shape.

1 Choosing where to set the Panel Screen.

Decide where to set the Panel Screen.

2 Attach the bracket to the Panel Screen.

As shown on the figure, attach the bracket to the panel using the enclosed screws.

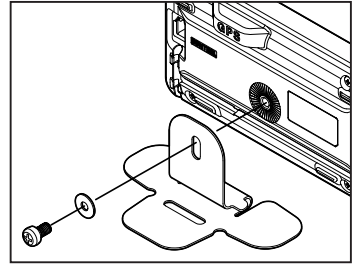

3 Attach the bracket using double-sided adhesive tape.

Remove the protective film on one side of the enclosed double-sided adhesive tape and paste it to the bottom of the bracket.

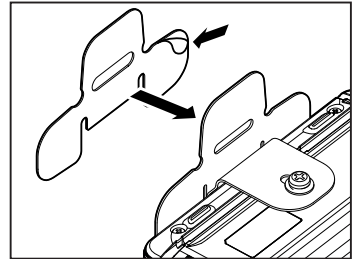

4 Attach the Panel Screen to the desired location.

Remove the protective film on the remaining side of the double-sided adhesive tape and paste the Panel Screen to the desired location of the vehicle.

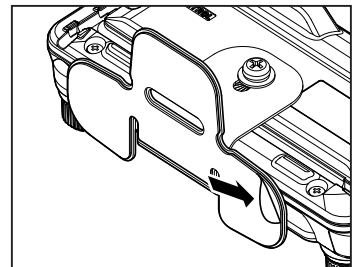

Names for various parts, Functional Parts and their Functions.

Description for Panel Screen

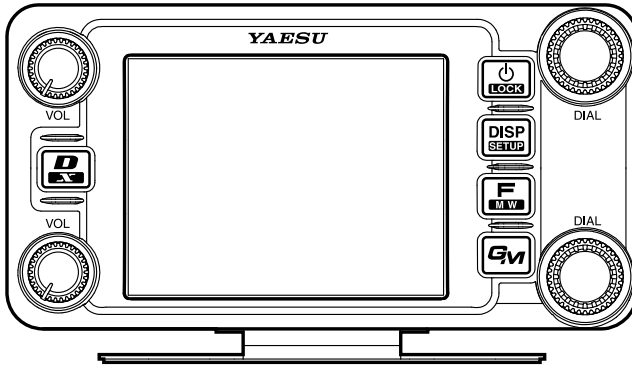

Pressing shortly switches between operating bands. When selecting operating band, press the shortly to fast forward the MHz indication.

Pressing and holding over 1 second switches the operating band in units of 5MHz

The volume can be adjusted with .

Power can be switched ON/OFF by pressing and holding over 1 second. Pressing shortly while the power is ON switches the key lock ON/OFF.

Pressing the shortly changes the view of the Display.

Reference See pages xx for details on the view of the Display.

Pressing and holding over 1 second displays the Setup Menu.

Pressing shortly displays the Function Menu.

Pressing and holding over 1 second switches to the Memory Recording Mode.

Pressing shortly switches the ARTS D ON/OFF.

Pressing and holding over 1 second stores ARTS D Group information of your station to the microSD memory card.

Pressing while transmitting sends ARTS D Group information of your station to the destination station.

Pressing the shortly switches between Analog/Digital Mode.

Pressing and holding over 1 second starts WiRES X.

Names for various parts, Functional Parts and their Functions.

Description about the Screen

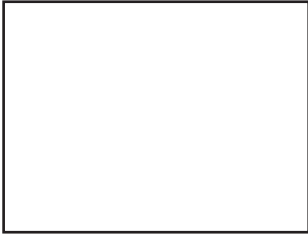

- [V/M]** Tapping **[V/M]** switches between VFO channels and Memory Channels.
- [SQL]** Squelch level can be adjusted by tapping **[SQL]**.
- [MUTE]** Tapping **[MUTE]** mutes reception tone.
- [SCOPE]** Tapping **[SCOPE]** switches the Band Scope Function ON/OFF.

When the Band Scope Function is ON, it appears as follows:



- ←Operating Frequency
- ←VOL Level/SQL Level
- ←S Meter/Destination Station Information
- ←Band Scope Area

Pressing  shortly switches to the next screen.

• ARTS/GMS Screen



- [BACK]** Returns to the previous screen.
- [LIST]** Displays the list of received messages.

Before Using This Equipment

Names for various parts, Functional Parts and their Functions.

● **BACK TRACK Screen**



- [Compass Unit]** Tapping **[Compass Unit]** saves current location information.
- [L1]** Tapping **[L1]** displays location information registered to L1.
- [L2]** Tapping **[L2]** displays location information registered to L2.

- [TX]** Tapping **[TX]** transmits the current location information/ID/TAG of your station to the destination station.
- [RCVD]** Tapping **[RCVD]** selects BACK TRACK ON/OFF for the destination station. When the BACK TRACK is ON, it appears in White. When the BACK TRACK is OFF, it appears in Grey. When a signal from the destination station with it's location information is received, it appears in orange.

● **NAVIGATION Screen**



- [Heading UP]** Tapping **[Heading UP]** switches between Heading Up and Nose Up.
- [DESTINATION]** Tapping **[DESTINATION]** displays the Point List to start navigation.
- [CLEAR]** Tapping **[CLEAR]** stops navigation.
- [CURRENT]** Tapping **[CURRENT]** displays the current location information.
- [LOCATION]**

The following screen appears when displaying the Point List.



- [BACK]** Tapping **[BACK]** returns to the previous screen and puts the navigation on standby.
- [NAVI]** Tapping **[NAVI]** returns to the previous screen and starts navigation.
- [EDIT]** Tapping **[EDIT]** allows you to edit names of Point List.
- [DEL]** Tap **[DEL]** allows you to delete Point List.
- [SORT]** Tapping **[SORT]** sorts Point Memory in the predetermined order.

Names for various parts, Functional Parts and their Functions.

● **ALTITUDE Screen**



- [CLEAR]** Tapping **[CLEAR]** deletes data being displayed.
- [Altitude Scale]** Tapping **[Altitude Scale]** allows you to change measurement unit of altitude being displayed.
- [Distance Scale]** Tapping **[Distance Scale]** allows you to change the measurement unit of distance being displayed.
- [CURRENT]** Tapping **[CURRENT]** displays detailed location information.
- [LOCATION]**

● **TIMER/CLOCK Screen**



- [MODE]** Tapping **[MODE]** toggles through **[CLOCK]**, **[LAP COUNTER]**, **[DOWN COUNTER]**.

● **LAP Timer Screen**



- [START]** Tapping **[START]** starts the Counter.
- [STOP]** Tapping **[STOP]** stops the Counter.
- [LAP]** Tapping **[LAP]** displays LAP value measured by Counter.
- [RESET]** Tapping **[RESET]** resets LAP value measured by Counter.
- [RECALL]** Tapping **[RECALL]** will display LAP value measured by Counter.

● **Down Timer Screen**



- [SETUP]** Tapping **[SETUP]** displays setting screen for time measurement.
- [RESET]** Tapping **[RESET]** returns to time measurement display screen.

Before Using This Equipment

Names for various parts, Functional Parts and their Functions.

• **GPS INFO Screen**



[CURRENT] Tapping **[CURRENT]** displays detailed location information.

[LOCATION MEMORY]

Save present location information to memory.

[1] Receiving Satellite Number

[1] Signal Strength High

[1] (Halftone 20%) Signal Strength Medium

[1] (Halftone 50%) Signal Strength Low

Description of Microphone (MH-48)



[UP] Raises the frequency up one step.

[DOWN] Lowers the frequency down one step.

[1] to [0] Input numbers and alphabet.

[*] Switch between VFO/MEMORY of operating band.

[#] Registers frequency to memory.

[A] Switches operating band to A band.

[B] Switches operating band to B band.

[C] Adjust DQL level.

[D] Switch the view of DISPLAY.

[P1] Sets SQL to OFF.

[P2] Moves to frequency set as HOME.

[P3] RPT SHIFT

[P4] TX POWER

[LOCK] Locks keys [UP] and [DOWN] to prevent miss operation.

[LAMP] Lights the lamp on the Microphone.

Reference

• Functions for [P1] to [P4] can be changed in **[OPTION]** → **[10 MIC PRG KEY]** of the Setup Menu.

Before Using This Equipment

Using the microSD Memory Card

Using a microSD memory card allows for the following functions.

- The function to backup this unit's information.
- The function to save Memory Data.
- The function to save the Set Mode.
- The function to save data other than images.
- The function to save the GPS Log Data.
- The function to save photo data captured with the optional camera mounted on microphone (MH-85A11U).

Usable microSD memory cards.

This unit supports microSD memory cards and microSDHC memory cards.

However, operation of commercially sold microSD cards and microSDHC memory cards are not guaranteed.

Refer to the following list for supported microSDHC memory cards.

Using the microSD Memory Card

Precautions for when using a microSD memory card.

- Do not bend or place heavy objects on top of microSD memory cards.
- If a microSD memory card has been formatted with a different device, may obstruct the proper storage of data. Reformat a memory card with this unit if it has been formatted with a different device.
- Do not remove a microSD memory card or turn off the power of this unit while data is being saved to a microSD memory card.
- Do not insert objects other than a microSD memory card into the microSD memory card slot.
- Do not forcefully remove an inserted microSD memory card.
- Do not use microSD memory cards other than those that are specified. Please contact our Amateur Customer Support for information about specified products.

Installing/removing microSD memory card

- 1 Press and hold  over 1 second.
Turn off the power of the main unit.

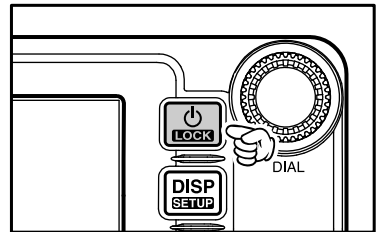

- 2 Insert microSD memory card.

As shown in the figure to the right, insert the microSD memory card into the slot until it clicks into place.

- Caution**
- Be careful not to insert the microSD memory card in the wrong direction.
 - Do not touch the terminal of the microSD card.

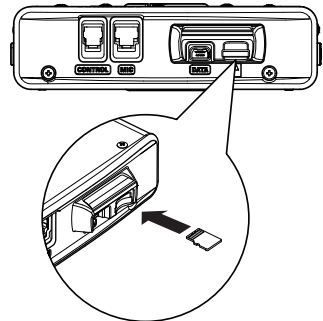

"SDCARD" appears in the upper left corner of the screen.







Using the microSD Memory Card

Formatting the microSD Memory Card

Follow the instructions below when formatting a new microSD memory card.



Precaution

Formatting a microSD memory card will erase all saved data. Check the data saved to the microSD memory card in use, before formatting the card.

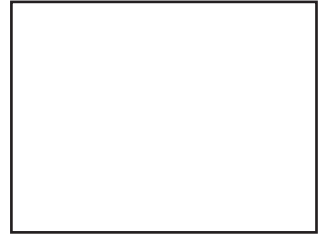
- 1 Press and hold  over 1 second.
Set Mode screen appears.
- 2 Tap [SD].
- 3 Tap [1 BACKUP].
- 4 Tap [FORMAT].
[SD CARD PUSH F KEY!] appears on screen.
- 5 Press .
[FORMAT? PUSH F KEY!] appears on screen.
Reference Tap [BACK] to cancel format.
- 6 Press .
Formatting starts.
Once format is finished, [SD CARD PUSH F KEY!] appears on screen.
- 7 Press and hold  over 1 second.
Exit from Set Mode.



Communication

- 1 Press and hold  over 1 second.
Turn on the power.
- 2 Adjust volume with **[VOL]**.
- 3 Tap **[SQL]**.
Adjust Squelch
- 4 Adjust frequency using .
Reference • The frequency can also be adjusted using [UP], [DOWN], and [0] to [9] on the microphone.
- 5 Speak by pressing **[PTT]** on the microphone.
- 6 Press and hold  over 1 second.
Turn off the power.





Reference

- The type of radio is set automatically.
- The type of radio can also be changed manually (See page xx).
- The frequency can also be selected with the [UP] and [DOWN] on the microphone.

Changing the Beep Sound.

The operation confirmation sound (Beep Sound), heard when keys are operated, can be changed.

- 1 Press and hold  over 1 second.
The Setup Menu appears.
- 2 Tap **[CONFIG]**.
- 3 Tap **[8 BEEP]** and select desired Beep Sound.
The Beep Sound will change in the following order each time **[8 BEEP]** is tapped.
[OFF] → [LOW] → [HIGH]
- 4 Press and hold  over 1 second
The Beep Sound is set and the screen returns to the previous screen.



Communication



Using the Timer Function

This unit is equipped with a Lap Timer and Down Timer.

Precaution





- Adjust the internal clock beforehand when using the timer function.(See page 000).

● Using the Lap Timer

- 1 Press  shortly.
 Press  shortly until clock appears.
- 2 Tap **[MODE]**.
 The Lap Timer appears.
- 3 Tap **[START]**.
 The Timer starts.
- 4 Tap **[LAP]**.
 The Lap Time is recorded every time **[LAP]** is tapped.
- 5 Tap **[STOP]**.
 The Timer stops.
 Tapping **[RESET]** deletes Lap Time.
 Tapping **[RECALL]** displays Lap Time that has been recorded in the past.
- 6 Press  shortly.
 Exits Timer Screen and returns to the previous screen.



● Using the Down Timer

- 1 Press  shortly.
 Press  shortly a few times until clock appears.
- 2 Tap **[MODE]** twice
 Down Timer appears.
- 3 Tap **[SETUP]**.
 The setting screen for time measurement appears.
- 4 Set time with .
 Rotate  and set **[TIME]** for time measurement.
 Tapping **[SETUP]** applies the selected time.
[MINUTE] can be set in the same way.

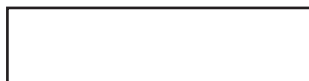
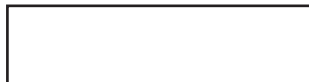

Communication

5 Tap [START].

The Down Timer starts.

Tap [STOP] to pause timer if you want to stop it in the middle.

When the set time is reached, [00:00'00] appears in green.

6 Press shortly.

Exits Timer Screen and returns to the previous screen.



The ALTITUDE function for measuring altitude.

The altitude of present location or change of altitude according to traveled distance can be displayed as a graph.

Precaution

- In order to use the ALTITUDE function, connect the optional GPS antenna unit.
- In order to display the ALTITUDE screen, set to [ALTITUDE:ON] of [DISPLAY] → [1 DISPAY SELECT] in the Top Menu beforehand.

1 Press shortly.

Press  shortly a few times until ALTITUDE screen appears.

2 Altitude appears.

The present altitude appears on the display.

Tapping [CLEAR] deletes accumulated data of altitude change.

Tapping [LOCATION MEMORY] saves information on present location.

3 Press shortly.

Press  shortly a few times until the screen returns to the previous one.

Locking Keys and Switches



and switches can be locked to prevent accidental changes in radio frequency during movement.

1 Press shortly.

[LOCK] appears on the display and the screen returns to the previous one.

Reference To Unlock, press [PTT] shortly again.

[UNLOCK] appears on the display and the screen will return to the previous one.

Reference

- Conditions for automatic Lock can be changed in the Setup Menu (See page 000).

Switching type of radio (mode) and conducting communication



In factory settings, this unit is set in [AUTO] mode and automatically selects the optimum mode (type of radio) according to frequency. The type of radio (mode) can be manually changed and conduct communication.

Using this unit, communication can be conducted in 4 forms: [AUTO (FM)], [FM], [NARROW FM], and [AM].

Select the desired mode and conduct communication with the following steps.

- 1 Press and hold  over 1 second.
The Setup Menu appears.
- 2 Tap [TX/RX].
- 3 Tap [MODE] and select desired Mode.
The Mode changes in the following order each time [MODE] is tapped.
[AUTO (FM)]: Automatically switches to the optimal type of radio according to frequency band.
[FM]: Only changes the selected frequency band to FM Mode.
[Narrow FM]: Only changes the selected frequency band to NFM Mode.
[AM]: Only changes the selected frequency band to AM Mode.

Reference Mode can also be selected by pressing .

- 5 Press and hold  over 1 second.
The Mode is set and the screen returns to the previous one.
- 6 Set frequency with .
Select frequency for communication.
- 7 Speak by pressing [PTT] on the microphone.
Speak with about 5cm between microphone and mouth.
- 8 Release [PTT].
Returns to reception state.

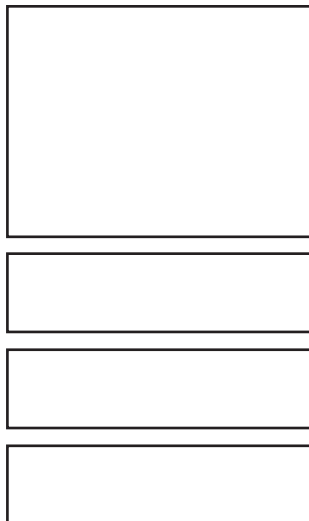

Switching type of radio (mode) and conducting communication

Changing Transmission Output

The transmission output can be lowered for when communicating with a transceiver near by, or to reduce battery consumption.

- 1 Press .
- 2 Tap **[Tx PWR]** and select desired transmission output.

The Transmission Output changes in the following order, each time **[Tx PWR]** is tapped.

[HI (5.0W)] → [LOW (OOW)] → [MID (OOW)]

Reference • Sensitivity can also be selected by pressing .



Reference

- Avoid long periods of continuous transmission. Doing so causes temperature of the unit to rise, and may lead to malfunction or burning injuries due to over heating.
- The current Output level is indicated under **[Tx PWR]** on the display.
- [OFF] appears on the display for frequencies where signal cannot be transmitted.
- This unit is set to [HI] in Factory setting.



Adjusting Microphone Sensitivity (MIC GAIN)

The Microphone Sensitivity can be adjusted.

- 1 Press and hold  over 1 second.
The Setup Menu appears.
- 2 Tap **[TX/RX]**.
- 3 Tap **[AUDIO]**.
- 4 Tap **[3 MIC GAIN]** and select desired Sensitivity.

The Sensitivity changes in the following order each time **[3 MIC GAIN]** is tapped.

[MIN] → [LOW] → [NORMAL] → [HIGH] → [MAX]

Reference • Sensitivity can also be selected by pressing the



• Factory Setting: NORMAL



- 5 Press and hold  over 1 second.
The MIC GAIN is set and the screen returns to the previous one.



Other Settings

Adjusting Time

This Unit is equipped with an internal clock. Not only does this clock display time, but also has a timer for automatically turning power ON and OFF at times set by the user. Adjust the time before using this function.

- 1 Press and hold  over 1 second.
Setup Mode appears.
- 2 Tap **[CONFIG]**.
- 3 Tap **[1 DATA & TIME ADJUST]**.
[DATA & TIME ADJUST] screen appears.
- 4 Tap **[SET]**.
The cursor moves to [MONTH].
- 5 Set Month.
Tap **[+]** or **[-]** to select Month.
- 6 Tap **[SET]**.
The cursor moves to [DAY].
- 7 Set Day.
Tap **[+]** or **[-]** to select Day.
- 8 Tap **[SET]**.
- 9 Repeat Step 5 to Step 6.
Set [YEAR], [HOUR], [MINUTE].
- 10 Press and hold  over 1 second.
The Date is set and the screen returns to the previous one.

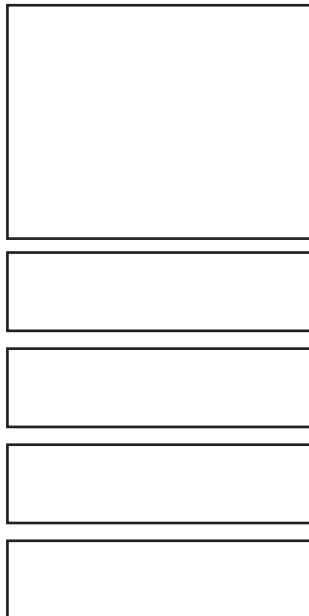

Note The Date/Time appears in the upper right corner of the screen.

Reference

- The accuracy of the clock is within 30 seconds per month at room temperature. The accuracy varies depending on the use conditions such as temperature.
- The accuracy may degrade when the battery is low or if it is the first time using this unit. Readjust the time under these circumstances.
- The calendar can display dates from January 1st, 2000 A.D. to December 31st, 2099 A.D.

Other Settings

Muting Sounds

If the sounds from A Band and B Band overlap and become difficult to hear during Dual frequency reception, the sound for bands other than operating band can be muted.

- 1 Press and hold  over 1 second.

The Setup Menu appears.

- 2 Tap [TX/RX].

- 3 Tap [AUDIO].

- 4 Tap [2 SUB BAND MUTE] and select Mute ON.

Mute is switched [ON] and [OFF] each time [2 SUB BAND MUTE] is tapped.

Reference • Mute can also be selected by pressing the .

- 5 Press and hold  over 1 second.

The Mute ON is set and the screen returns to the previous one.

Reference

Tap [MUTE] displayed on the bottom of the screen to switch the Mute Function to OFF.

Mute is switched [ON] and [OFF] each time [MUTE] is tapped.



Adjusting Squelch Level

You can mute the raspy noise heard when no signal is being received. The squelch level can be adjusted separately for two broadcasts (NFM and AM) received on the A-band and B-band. When the squelch level is increased, the noise is more liable to disappear but, in some cases, it becomes difficult to receive weak signals. Adjust the squelch level as required.

- 1 Tap [SQL].

- 2 Adjust Squelch level with .

Adjust the Squelch level by rotating the upper  for A Band, and lower  for B Band.

Reference • Squelch level can be adjusted from 0 to 8.

• Factory Setting: Level 1

- 3 Tap [SQL].

The Squelch level is set and the screen returns to the previous one.



Manually switching frequency steps

In factory settings, this unit is set to [AUTO (Step)] mode and automatically selects the optimum frequency step according to reception frequency. These frequency steps can be manually changed.

- 1 Press and hold  over 1 second.

The Setup Menu appears.

- 2 Tap [CONFIG].

- 3 Tap [7 FM AM STEP] and select [AUTO].

[AUTO] appears in orange.

- 4 Set frequency with .

The frequency step changes in the following order, each time  is rotated.

[AUTO] → [5.00KHz] → [6.25KHz] → [10.00KHz] → [12.50KHz] → [15.00KHz] → [20.00KHz] → [25.00KHz] → [50.00KHz] → [100.00KHz]

Reference Mode can also be selected by pressing the .

- 5 Tap [7 FM AM STEP].

The selected frequency changes from orange to green and set as current setting.

- 6 Press and hold  over 1 second.

The frequency step is set and the screen returns to the previous one.



Resetting applied settings

Settings and memory content can be returned to factory settings.

- 1 Press and hold  over 1 second.

The Setup Menu appears.

- 2 Tap [RESET/CLONE].

Reset screen appears.

- 3 Tap items to reset.

Select items to reset.

[1 FACTORY RESET]: Returns all applied setting to factory settings.

[2 PRESET]: Registers the preset screen.

[3 RECALL PRESET]: Displays the preset screen.

[4 MEM CH RESET]: Erases only the registered memory channels.

* Settings applied in the Setup Menu are not erased.

[5 MEM CH SORT]: Sorts memory registered to A/B Bands.

[6 ARPS RESET]: Returns setting for ARPS to factory settings.

[7 CLONE]: Copy settings of this unit to another transceiver.

- 4 Tap [OK?]

Settings and memory are reset and returned to factory settings.

Reference Tap [Cancel] to cancel Resetting.

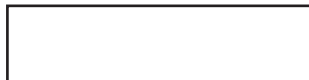

Repeater Operation

Communicating Via the Repeater





FTM-400DR supports an ARS (Automatic Repeater Shift) function which allows you to perform communication automatically just by setting the reception frequency to the repeater frequency (439.000 to 440.000 MHz).

- 1 Set the reception frequency to repeater frequency.
- 2 Perform transmission while pressing [PTT].

During transmission, a 88.5Hz tone signal and a radio wave whose frequency is 5 MHz lower than the reception frequency are emitted.



Reference

- Pressing  and then tapping [REV] produces the “reverse” state where the transmission frequency and the reception frequency are temporarily reversed, allowing you to check whether you can communicate with the remote station directly.
- The  on the display blinks while in the “REVERSE” state.
- Pressing  then tapping [REV] again cancels the “REVERSE” state.
- Press and hold  over 1 second to change the Setup Menu. This allows you to use the repeater more conveniently.
 - [CONFIG] → [4 AUTO RPT SHIFT] You can deactivate the ARS function.
 - [CONFIG] → [5 RPT SHIFT] You can set the repeater shift direction.
 - [CONFIG] → [6 RPT SHIFT FREQ] You can change the repeater shift step.

Communicating Via the Repeater Using a Tone Signal Other Than the 88.5Hz Tone Signal

- 1 Set the reception frequency to repeater frequency.
- 2 Press and hold  over 1 second.
- 3 Tap [CONFIG].
- 4 Tap [5 RPT SHIFT] and select [-].

Switches between [OFF] → [-] → [+] each time [5 RPT SHIFT] is tapped.

Reference • Factory Setting: OFF

- 5 Tap [6 RPT SHIFT FREQ].

The frequency appears in orange.
- 6 Set frequency with .

Rotate the  and select the desired tone frequency.

- 7 Tap [6 RPT SHIFT FREQ].

The selected frequency will change from orange to green and be applied as the current setting.

Reference • Frequency can also be selected by pressing the .

Repeater Operation

- 8 Press and hold  over 1 second.
The tone frequency is set and the screen returns to the previous one.
- 9 Perform transmission while pressing [PTT].
During transmission, the tone signal that has been set and radio wave whose frequency is 5 MHz lower than the reception frequency are emitted.

Reference

The settings can be stored in the memory. (Storing in the memory (See page 000)).

Wide variety of Memory Functions

FTM-400DR provides the following various types of memory channels in addition to the regular memory channels (500 channels each for both A and B band).

- [Skip Search Memory] that allow you to skip unwanted frequencies during VFO scanning.
- 9 sets of [memory channels for Programmable Memory Scanning (PMS)] respectively for both A band and B band.

An operating frequency, operation mode (type of radio), and other operational information can be stored for each regular memory channel, or PMS memory channel.



- Operating frequency
- Operation mode
- Memory tag
- Repeater information
- Tone information
- DCS information
- Antenna squelch information
- Memory skip information
- Transmission Output

Registering to Memory

Precaution

Content stored in memory can be erased due to incorrect operation, static electricity, or electrical noise. Memory content can also be erased during malfunction or repair. Content that is stored in memory should be written on paper or backed up on a microSD memory card.

The FTM-400DR allows you to use 500 memory channels respectively for both A band and B band.

- 1 Switch to VFO mode.
- 2 Select frequency with .
Select the frequency to register to the memory.
- 3 Press and hold  over 1 second.
The register to memory screen appears.
- 4 Tap [MW].
The character entry screen appears.

Reference Memory can also be named (See page 000).

- 5 Tap [ENT].
The memory write operation is completed, and the registered frequency appears on screen.

Reference Tap [Cancel] to cancel registering to memory.





Reference

- 145.000MHz is registered to memory channel 1 in factory settings. Although this frequency can be changed, it cannot be erased.
- The frequency which has previously been registered to a memory channel can be overwritten with a new frequency.
When you intend to register a new frequency into the memory, an unregistered memory channel is displayed.

Wide variety of Memory Functions

Split Memory

Two different frequencies, one for reception and other for transmission can be registered to a memory channel.



- 1 Register reception frequency to the memory.
Reference Refer to the [Registering to Memory] above, for registering frequency.
- 2 Select transmission frequency in VFO mode.
- 3 Press  for longer than a second.
 The register to memory screen appears.
- 4 Tap **[Reception Frequency]**.
 Select the reception frequency to specify from the memory list.
- 5 Tap **[TX IN]**.
 The character entry screen appears.
Reference The radio frequency can also be named (See page 000).
- 6 Tap **[ENT]**.
 Registration to memory completes and the frequency appears on screen.
 When you recall the memory channel of which you registered two different frequencies, one for reception and the other for transmission, the  icon appears on screen.



Using Memory

Recalling a Memory Channel

Recall a registered memory channel in the following procedure:

- 1 Tap **[V/M]**.
 The Memory mode is selected, and the memory channel you used last appears on screen.
 - 2 Select a memory channel with .
 Select the memory channel to use.
Remark • Pressing and holding  over 1 second skips channels quickly in step of 10 channels.
- Tapping **[V/M]** again returns to VFO Mode.

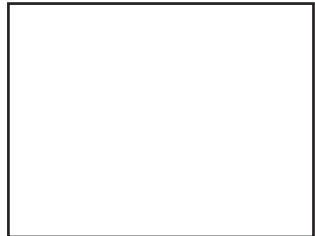

Reference

- Unregistered memory channels are skipped.
- By default, the priority memory channel used as the priority channel for the dual receive function was set to the memory channel 1. "P" appears at the upper right of the memory channel number (See page 000).

Wide variety of Memory Functions

Recalling the Home Channel

- 1 Press **[GM]** shortly.

Home Channels appear on screen.

Reference • Selecting the frequency with  returns to VFO Mode.

Returning to the Previous Frequency

- 1 Press **[GM]** shortly.

The frequency selected before recalling the home channel appears on screen.

• Changing a Home Channel Frequency

You can change a default home channel frequency.

- 1 Switch to VFO mode.

- 2 Set frequency with .

- 3 Press and hold **[F.MEMO]** over 1 second.

Write to memory screen appears.

- 4 Tap **[▲]** or **[▼]** and select **[HOME]**.

It can also be selected by pressing .

- 5 Tap **[MW]**.

The character entry screen appears.

Reference The radio frequency can also be named (See page 000).

- 6 Tap **[ENT]**.

Writing to memory I completes and the changed frequency appears on screen.



Deleting Memory

- 1 Press **[DISP SETUP]** 1M for longer than a second.

The Setup Menu appears.

- 2 Tap **[MEMORY]**.

- 3 Tap **[3 MEM EDIT]**.

Reference It can also be selected by pressing .

- 4 Tap the memory to delete.

- 5 Tap **[DEL]**.

The deletion confirmation screen appears.

- 6 Tap **[OK?]**.

Memory is deleted.

Reference • Tapping **[Cancel]** cancels deletion.

• To continue deleting memory, repeat steps 4 through 6.

- 7 Press and hold **[DISP SETUP]** over 1 second.

Returns to the previous screen.



Wide variety of Memory Functions

Precaution



- Memory channel 1 cannot be deleted.

Reference

The memory channel specified as a home channel cannot be deleted. Before deleting it, specify another memory channel as a home channel.

Changing the display method of Memory Tags.

The display method of name and frequency assigned to memory tags can be changed.

- 1 Switch to Memory Mode.
Display a memory channel to change the display method for the memory tag.
- 2 Press and hold  over 1 second.
The Setup Menu appears.
- 3 Tap **[MEMORY]**.
- 4 Tap **[2 ALPHA TAG SIZE]** and select size.
Size switches between [SMALL] and [LARGE] each time **[2 ALPHA TAG SIZE]** is tapped.
- 5 Press and hold  over 1 second.
The selected size is set and the screen returns to the previous one.

Reference Factory Setting: SMALL



Using the Scanning Function

The FTM-400DR supports the following four scan modes:

- (1) VFO Scan
- (2) Memory Scan
- (3) Programmable Memory Scan
- (4) Selected Memory Channel Scan

VFO Scan

- 1 Switch to the VFO mode, and then select a band to scan.
- 2 Press  shortly.
The Function Menu appears.
- 3 Tap **[SCAN]**.

Scanning (SCAN) starts toward higher frequencies.

- Reference**
- Pressing and holding [UP] or [DOWN] over 1 second also starts scanning.
 - When a signal is received during scanning, a beep is emitted and scanning pauses for 5 seconds and then resumes.
 - The scan direction (HIGH/LOW) can be set in the **[SCAN]** → **[2 SCAN DIRECTION]** of the Setup Menu.
 - The operation to perform when scanning stops can be set in the **[SCAN]** → **[3 SCAN RESUME]** of the Setup Menu.



Canceling Scanning

To cancel scanning, tap **[SCAN]** or **[PTT]** on the microphone.

Reference

- For the operation to perform when scanning stops, see “Setting a Reception Method When Scanning Stops” on page (See page 000).

Setting a Reception Method When Scanning Stops

When scanning stops, you can select one of the following three reception methods:

- (1) The signal is received for the specified period of time, and then scanning resumes.
You can specify this period of time to 1 second, 3 seconds, or 5 seconds.
- (2) The signal is received until it fades out. Two seconds after the signal fades out, scanning resumes. “BUSY” appears on screen.
- (3) Scanning stops and the current frequency is received. “HOLD” appears on screen.

Using the Scanning Function

- 1 Press and hold  over 1 second.
The Setup Menu appears.
- 2 Tap [**SCAN**].
- 3 Tap [**3 SCAN RESUME**] and select desired reception method.

The reception method changes in the following order each time [**3 SCAN RESUME**] is tapped.

[BUSY] → [HOLD] → [1sec] → [3sec] → [5sec]

- Reference**
- It can also be selected by pressing .
 - Factory Setting: 5 seconds

- 4 Press and hold  over 1 second.
The reception method when scanning stops is set and the screen returns to the previous one.

Reference

- The reception method selected here is also applied to [VFO Scanning], [Programmable Memory Scanning], [Memory Scanning], and [Dual Reception].

Memory Scanning

Frequencies registered to the memory can be scanned in the order of memory channel number.

- 1 Switch to Memory mode and recall a memory channel.
- 2 Press  shortly.
The Function Menu appears.
- 3 Tap [**SCAN**].
Scanning (SCAN) is performed toward higher memory channel numbers.

When a signal is received during scanning, a beep is emitted and scanning pauses for 5 seconds and then resumes.

- Reference**
- Pressing and holding [UP] or [DOWN] over 1 second also starts scanning.
 - To stop scanning, tap [**SCAN**] or [PTT] on the microphone.

Reference

- Even during scanning, you can adjust the squelch by tapping [**SQL**].
Tapping [**SQL**] again terminates squelch adjustment.
- For the operation to perform when scanning stops, see "Setting a Reception Method When Scanning Stops" on page (See page 000).

Using the Scanning Function

● Setting the Scan Method.

The scanning method to scan all memory channels or only selected memory channels can be set in the Setup Menu.

- ALL MEM: Scans all memory channels
- SELECT MEM: Only scans selected memory channels

1 Press and hold  over 1 second.

The Setup Menu appears.

2 Tap [MEMORY].

3 Tap [MEM SCAN TYPE] and then select [SELECT MEM].

The scanning method switches between [ALL MEM] and [SELECT MEM] each time [MEM SCAN TYPE] is tapped.

Reference • The scanning method can also be selected by pressing the .

4 Press and hold  over 1 second.

The scanning method is set and the screen returns to the previous one.

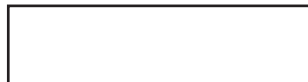

● Specifying a Skip/Selected Memory Channel

You can specify two types of memory channels to scan: memory channels to skip and selected memory channels to scan, for effective memory scanning.

Skip memory channel: You can specify memory channels that need not be scanned during memory scanning.

Selected memory channel: When [MEM SCAN TYPE] is set to [SELECT MEM], only the specified memory channels are scanned during memory scanning.

Memory channels to skip and selected memory channels to scan can be specified in the 2 methods following.

- (1) Collectively select memory channels in the Memory Write screen.
- (2) Individually select memory channels when scanning.

(1) Collectively specifying memory channels in the Memory Write screen.

1 Press and hold  over 1 second.

The Memory Write screen appears.

2 Tap the memory to select.

Select memory by tapping it.

3 Tap [SKIP/SEL].

The scanning method switches between [SKIP], [SELECT], and [OFF], each time [SKIP/SEL] is tapped.

Reference • The scanning method can also be selected by pressing the .

- To continue selecting memory channels, repeat steps 2 through 3.



Using the Scanning Function

- 5 Press and hold  over 1 second.
Returns to the previous screen.

(2) Individually select memory channels when scanning

- 1 Switch to Memory mode and then recall the memory channels to specify as memory channels to skip or selected memory channels to scan.
- 2 Press  shortly.
The Function Menu appears.
- 3 Tap **[SKIP/SEL]** and set [SKIP] or [SEL].
The scanning method switches between [SKIP] and [SEL] each time **[SKIP/SEL]** is tapped.



Reference • The scanning method can also be selected by pressing the .

- 4 Press  shortly.
The memory channels to skip/selected memory channels to scan are set and the screen returns to the previous one.

• Scanning only memory channels selected in the specified memory.

- 1 Switch to Memory mode and then recall the memory channels selected for scanning.
- 2 Tap **[SCAN]**.
Only the memory channels selected in the specified memory are scanned.



- Reference**
- Pressing and holding [UP] or [DOWN] over 1 second also starts scanning.
 - Scanning (SCAN) is performed toward higher memory channel numbers.
 - When a signal is received during scanning, a beep is emitted and scanning pauses for 5 seconds and then it's frequency is received.
 - To cancel scanning, tap **[SCAN]** or [PTT] on the microphone.

Programmable Memory Scan (PMS)

Writing into a Programmable Memory

9 sets of PMS memory channels (L1/U1 to L9/U9) are available. Specify the lower limit frequency of the frequency range you want to scan for “L*”, and the upper limit frequency for “U*”. Enter a number between 1 and 9 for “*”. Use the same number for the lower and upper limit.

Scanning Function

Using the Scanning Function

- 1 Switch to VFO mode.
- 2 Select a frequency with .
 Select a frequency for the lower limit.

Caution • Make sure to set the frequency set for the lower limit (P1L) lower than the frequency set as the upper limit (P1U).

- 3 Press and hold  over 1 second.
 Memory Write screen appears.

- 4 Tap [\blacktriangle] or [\blacktriangledown] to select [P1L].
 It can also be selected by pressing .

- 5 Tap [MW].
 The character entry screen appears.

Reference The radio frequency can also be named (See page 000).

- 6 Tap [ENT].
- 7 Set frequency with .
 Select a frequency for the upper limit.

- 8 Press and hold  over 1 second.

- 9 Tap [\blacktriangle] or [\blacktriangledown] to select [P1U].
 It can also be selected by pressing .

- 10 Tap [MW].
 The character entry screen appears.

Reference The radio frequency can also be named (See page 000).

Writing to the programmable memory ends and the screen returns to the previous one.

Example: Specification of the lower limit frequency “433.200 MHz” and the upper limit frequency “433.700 MHz” for PMS

Lower limit: L1

Upper Limit: U1

Precaution

The difference between the upper limit frequency and the lower limit frequency for PMS must be 100 kHz or more.

Using the Scanning Function

Performing Programmable Memory Scan

The programmable memory allows you to scan the specified frequency range in the same frequency band.

1 Switch to Memory mode.

Recall the PMS memory storing the lower limit frequency or upper limit frequency.

2 Press  shortly.

3 Tap **[SCAN]**.

Programmable memory scanning starts.

Reference • Pressing and holding [UP] or [DOWN] over 1 second also starts scanning.

- When a signal is received during scanning, scanning pauses for 5 seconds.
- The scanning resumes 5 seconds after signal has been received.
- To cancel scanning, tap **[SCAN]** or [PTT] on the microphone.



Precaution

- When the lower/upper limit frequency is not properly specified, program memory scanning is not performed properly.

Reference

- If PMS memory channels have already been assigned to L1/U1 to L9/U9, selecting a PMS number in the VFO scanning procedure described on page 56 allows you to skip step 1 described above.
- When a skip memory (**) is specified for “L*” or “U*” or when the lower/upper limit frequency is not properly specified, program memory scanning is not performed properly.
- Even during scanning, you can adjust the squelch in the following procedure:
Tap **[SQL]** → Adjust squelch with  → Tap **[SQL]**

Searching for a Signal Using a Signal Strength Graph Band Scope Function

During mono band reception in the VFO mode, use states of channels (strengths of channel signals) around the current frequency set as center [▼] can be graphically displayed on screen.

- 1 Tap [V/M].
The mode switches to Mono Band.
- 2 Tap [SCOPE].
The SCOPE screen appears.
- 3 Turn the  knob to move the ▼ icon to the signal position.
The signal at the center frequency can be received.
- 4 Tap [SCOPE].
The Band Scope is deactivated.



Reference

- When band scope channel is ± 5 , numeric values representing signal strengths are displayed in the graph.
- The band scope channel interval is the same as the VFO frequency step.
- The band scope channel interval can be changed in Setup Menu, [Display] → [3 BAND SCOPE].

Dual Reception (DW) Functions

This FTM-400DR supports the following two dual reception functions:

- (1) Dial dual reception
- (2) Memory dual reception

The signal of the specified memory channel (Home Channel) is checked at intervals of about 5 seconds. If this signal is detected, it is received.

Example: Checking Home Channel while receiving [145.500MHz].



Frequency being received



The signal of the Home Channel is checked at intervals of about 5 seconds.



If the signal of the Home Channel is received, the decimal point blinks.

Dial Dual Reception

VFO mode → Home channel

- 1 Adjust to frequency desired for reception.
Adjust to the frequency to receive using  knob.
- 2 Press  shortly.
The Function Menu appears.
- 3 Tap [DW].
If [DW] is not displayed in the Function menu, tap [NEXT].



- 4 Dual reception starts.

The signal of home channel is received around every 5 seconds.



When a signal of the home channel is received, the frequency changes to that of the home channel.

To cancel the dual reception, press  shortly again and tap [DW].

Dual Reception (DW) Functions

Memory Dual Reception

Memory channel → Home Channel

- 1 Switch to Memory Mode.
- 2 Adjust to the memory channel to receive.
 Adjust to the memory channel to receive using  knob.
- 3 Press  shortly.
 The Function Menu appears.
- 4 Tap [DW].
 If [DW] is not displayed in the function menu, tap [NEXT].
- 5 Dual reception starts.
 The signal of home channel is received around every 5 seconds.
 When a signal of the home channel is received, the frequency changes to that of the home channel.
 To cancel the dual reception, press  shortly again and tap [DW].

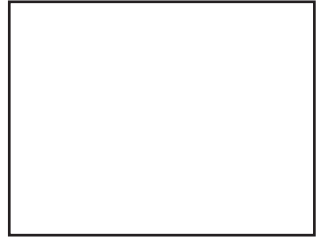

Precaution



- Make sure to set home channel prior to using memory dual reception.

Reference

- If a signal of dual reception is received, its frequency is received for 5 seconds and then dual reception resumes. Even while receiving the home channel, dual reception can be canceled by pressing [PTT] on the microphone and can perform transmission using that frequency.
- The operation to perform when dual reception is running can be set in the [SCAN] → [1 DUAL WATCH STOP] of the Setup Menu.

Using the DTMF Function.

“DTMF (Dual Tone Multi Frequency) tones” refer to the tones (beep boop beep) heard from the receiver of the push-button phone. You can register the telephone number for phone patch connection to the public telephone line, etc. with a DTMF code comprising up to 16 characters (for up to 9 channels).

- 1 Press and hold  over 1 second.
 The Setup Menu appears.
 - 2 Tap [SIGNALING].
 - 3 Tap [4 DTMF MEMORY].
 The DTMF Memory screen appears.
- Reference** This can also be selected by pressing the .







Using the DTMF Function.

- 4 Tap a channel to select.
 Select a number (1-9) to which the DTMF code is to be registered.
- 5 Tap the DTMF Code to register.
 Tap the numerical keypad and enter the DTMF code o register.
Reference • The DTMF code can also be entered using the numerical keypad on the Microphone.
 • Tap **[Cancel]** if an incorrect number is entered.
- 6 Tap **[ENT]**.
 The DTMF code is registered to the selected number.
- 7 Press and hold  over 1 second.
 Returns to the previous screen.



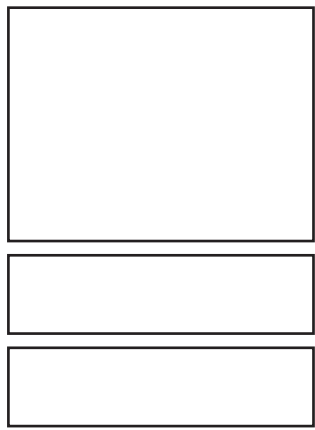

Sending the Registered DTMF Code

- 1 Press and hold  over 1 second.
 The Setup Menu appears.
- 2 Tap **[SIGNALING]**.
- 3 Tap **[3 AUTO DIALER]** and select **[ON]**.
 Tapping **[3 AUTO DIALER]** switches between **[ON]** and **[OFF]**.
Reference This can also be selected by pressing the .
- 4 Press and hold  over 1 second.
 Returns to the previous screen.
- 5 Press  shortly.
 The Function Menu appears.
- 6 Tap **[DTMF]**.
 If **[DTMF]** is not displayed in the function menu, tap **[NEXT]**.
 Tapping **[DTMF]** switches through registered DTMF Codes.
- 7 Press  shortly.
 Returns to the previous screen.
- 8 Press **[PTT]**.
 Pressing **[PTT]** on the Microphone automatically sends DTMF code.
- 9 Release **[PTT]**.
 Even after **[PTT]** on the microphone is released, sending of the DTMF signal continues until it is completed.



Useful Functions

Sending a DTMF Code Manually

- 1 Press and hold  over 1 second.
The Setup Menu appears.
- 2 Tap **[SIGNALING]**.
- 3 Tap **[3 AUTO DIALER]** and select [OFF].
Tapping **[3 AUTO DIALER]** switches between [ON] and [OFF].
- 4 Press and hold  over 1 second.
Returns to the previous screen.
- 5 Select a number from [1] through [9] while pressing [PTT]
Tap the numerical keypad and enter the DTMF code to send.
- 6 Release [PTT].
Even after [PTT] on the microphone is released, sending of the DTMF signal continues until it is completed.



Reference

- A DTMF code is a combination of two frequencies.

	1209Hz	1336Hz	1477Hz	1633Hz
697Hz	1	2	3	A
770Hz	4	5	6	B
852Hz	7	8	9	C
941Hz	*	0	#	D

Using the Tone Squelch Function

The tone squelch opens the squelch only when a signal containing the specified frequency tone is received. Use of the digital code squelch (DCS) opens the squelch only when a signal containing the specified DCS code is received. The tone squelch function blocks monitoring of communications between other stations even when waiting for call by a specific station for a long time.

1 Press **[F.M.W.]** shortly.

The Function Menu appears.

2 Tap **[SQL]** to select a squelch type.

The squelch type changes in the following order each time **[SQL]** is tapped:

- [NOISE] → [T-TX] → [T-TRX] → [T-REV] →
- [D-TRX PRGM] → [PAGER] → [JR] → [D-TX] →
- [TT/DR] → [DT/TR]

The display for **[SQL]** changes according to the selected squelch type.

3 Press **[F.M.W.]** shortly.

The squelch type is set and the screen returns to the previous one.

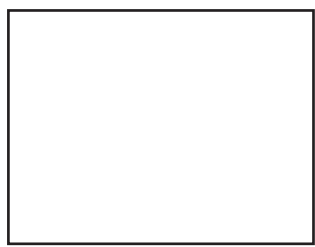

Reference





- The tone squelch setting or the DCS setting is also effective for scanning. If scanning is performed with the tone squelch or the DCS function turned on, it stops only when a signal containing a tone of the specified frequency or a signal containing the specified DCS code is received.

Display	Operation
NOISE	XXXXXXXXXXXXXXXXXXXXXXXXXXXXXXXXXXXX.
T-TX	XXXXXXXXXXXXXXXXXXXXXXXXXXXXXXXXXXXX.
T-TRX	XXXXXXXXXXXXXXXXXXXXXXXXXXXXXXXXXXXX.
T-REV	XXXXXXXXXXXXXXXXXXXXXXXXXXXXXXXXXXXX.
D-TRX PRGM	XXXXXXXXXXXXXXXXXXXXXXXXXXXXXXXXXXXX.
PAGER	Turns on a new pager function ("PAG" appears). When using FTM-400DR with your friends, specifying personal codes (each code is composed of two tones) allows calling a specific station.
JR	Turns on the no-communication squelch function of the JR radio ("JR" appears). Mutes the 2280 MHz no-communication signal tone which is heard when no communication is performed.
D-TX	XXXXXXXXXXXXXXXXXXXXXXXXXXXXXXXXXXXX.
TT/DR	XXXXXXXXXXXXXXXXXXXXXXXXXXXXXXXXXXXX.
DT/TR	XXXXXXXXXXXXXXXXXXXXXXXXXXXXXXXXXXXX.

Using the Tone Squelch Function

Selecting a Tone Frequency

The Tone frequency can be selected from 50 frequencies between 67.0Hz to 254.1Hz.

- 1 Select the operating frequency.
- 2 Press and hold  over 1 second.
The Setup Menu appears.
- 3 Tap **[SIGNALING]**.
- 4 Tap **[1 TONE SQL FREQ]**.
The tone frequency appears in orange.
- 5 Select a frequency with the .
- 6 Press  shortly.
The tone frequency is set and it appears in green.
- 7 Press and hold  over 1 second.
Returns to the previous screen.

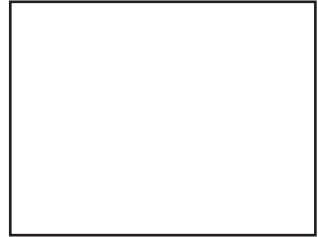



Reference

- The tone frequency set using the above-described procedure is also effective when only the tone is sent out.
- By default, the tone frequency is set to 88.5Hz.

Searching for the Frequency of the Tone Squelch Used by the Remote Station

The frequency of the tone squelch used by the remote station can be searched for and displayed.

- 1 Press  shortly.
The Function Menu appears.
- 2 Tap **[SQL]** and select **[T-TRX]**.
Tap until the **[SQL]** display switches to **[T-TRX]**.
- 3 Press  shortly.
- 4 Tap **[SQL]**.
Search for the tone frequency starts.
When a coincident frequency is detected, a beep is emitted and search stops temporarily. The detected tone frequency blinks.

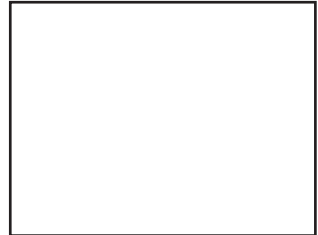







Reference

- For the operation to perform when scanning stops, see “Selecting a Reception Method When Scanning Stops” on page (See page 000).

Using the Tone Squelch Function

Selecting a DCS Code

You can select a DCS code from among 104 DCS codes (023 to 754).

- 1 Selecting the operating frequency.
- 2 Press and hold  over 1 second.
The Setup Menu appears.
- 3 Tap **[SIGNALING]**.
- 4 Tap **[2 DCS CODE]**.
The DCS code number appears in orange.
- 5  Select DCS code number with the .
- 6  Press  shortly.
The DCS code is set and DCS code number appears in green.
- 7 Press and hold  over 1 second.
Returns to the previous screen.





Reference

- By default, the DCS code is set to "023".

Searching for the Frequency of the DCS Used by the Remote Station

The DCS code used by the remote station can be searched for and displayed.

- 1 Press  shortly.
The Function Menu appears.
- 2 Tap **[SQL]** and select **[D-TRX]**.
Tap until the **[SQL]** display switches to **[D-TRX]**.
- 3 Press  shortly.
- 4 Tap **[SQL]**.
Search for the DCS code starts.
When a coincident DCS code is found, a beep is emitted and search stops temporarily. The found DCS code blinks.

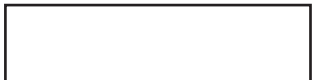





Reference

- For the operation to perform when scanning stops, see "Selecting a Reception Method When Scanning Stops" on page (See page 000).

Notification of Call from a Remote Station by the Bell

Call from a remote station (reception of a signal containing a coincident tone or DCS) can be notified by the bell sound and the 📞 icon blinking on on screen.

- 1 Press and hold  over 1 second.
The Setup Menu appears.
- 2 Tap **[SIGNALING]**.
- 3 Tap **[7 BELL RINGER]**.
The set value for BELL RINGER appears in orange.
- 4 Turn the  to select a number of times the bell rings.
The number of times the bell rings changes in the following order, each time  is rotated.
[OFF] → [1time] → [3times] → [5times] → [8times] → [CONTINUE]
- 5 Press  shortly.
The number of times the bell rings is set and appears in green.
- 6 Press and hold  over 1 second.
Returns to the previous screen.

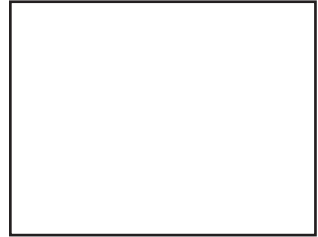

Calling Only a Specific Station New Pager Function

When using FTM-400DR with your friends, specifying personal codes (each code is composed of two CTCSS codes) allows only a specific station to be called. Even if the called person is not near his or her FTM-400DR, the information on the screen indicates that he or she has been called.



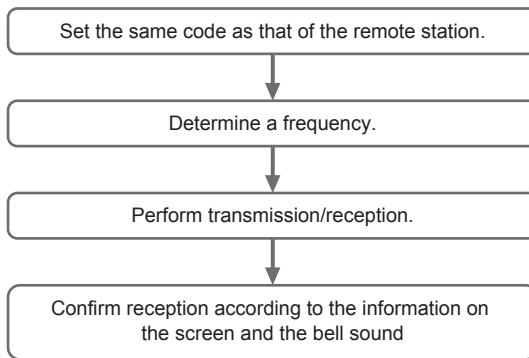





Flow of Operation to Use the Pager Function



Calling Only a Specific Station New Pager Function

Setting the Code of Your Station

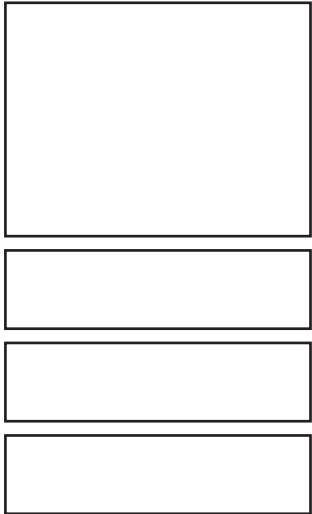

Set the “personal code (your code)” used to be called by other stations.

- 1 Press and hold  over 1 second.
The Setup Menu appears.
- 2 Tap **[SIGNALING]**.
- 3 Tap **[5 PAGER CODE]**.
The Pager Code Settings screen appears.
- 4 Tap **[RX CODE 1]**.
The code number appears in orange.
- 5 Select code with the .
Turn the  to select a code.
Turn the  to select the first code from among 1-50
- 6 Press  shortly.
The first code is set and appears in green.
- 7 Tap **[RX CODE 2]**.
The code number appears in orange.
- 8 Turn the  to select a code.
Turn the  to select the second code from among 1-50.
- 9 Press  shortly.
The second code is set and appears in green.
- 10 Press and hold  over 1 second.
The code of your station is set and the screen returns to the previous one.



- Reference**
- Factory Setting: [05 47]
 - The first and second codes contained in your personal code may be inverted, i.e., “05 47” and “47 05” are recognized as being the same code.
 - If the same personal code (group code) is specified for all persons, all persons can be called at the same time.

Turning on the New Pager Function



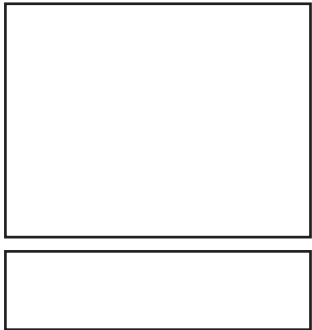





- 1 Press  shortly.
The Function Menu appears.
- 2 Tap **[SQL]** and select **[PAGER]**.
Tap until the **[SQL]** display switches to **[PAGER]**.
- 3 Press  shortly.
- 4 Tap **[SQL]**.
Now, you can “call” or “wait” a remote station using the new pager function.



Communicating with a Specific Remote Station

Calling Only a Specific Station New Pager Function

Calling a Specific Station

- 1** Press and hold  over 1 second.
The Setup Menu appears.
- 2** Tap **[SIGNALING]**.
- 3** Tap **[5 PAGER CODE]**.
The Pager Code Settings screen appears.
- 4** Tap **[TX CODE 1]**.
The code number appears in orange.
- 5** Turn the  to select a code.
Turn the  to select the first code from among 1-50
- 6** Press  shortly.
The first code is set and appears in green.
- 7** Tap **[TX CODE 2]**.
The code number appears in orange.
- 8** Turn the  to select a code.
Turn the  to select the second code from among 1-50.
- 9** Press  shortly.
The second code is set and appears in green.
- 10** Press and hold  over 1 second.
The code of remote station is set and the screen returns to the previous one.
- 11** Tap **[SQL]**.
- 12** Press [PTT] on the microphone.
This starts calling the remote station.



Calling Only a Specific Station New Pager Function

Being Called by the Remote Station (Standby Operation)

If you use the new pager function at the same frequency as that of the remote station, [PAG] displayed on the screen changes to [PIN], allowing you to check that you have been called by the remote station.

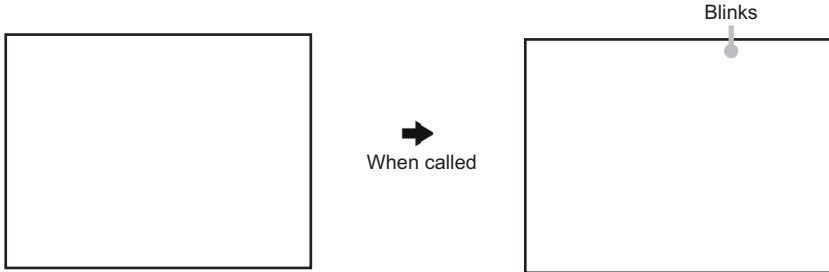

Setup Menu

Settings for the Setup Menu

The Setup Menu is a menu for selecting and setting various functions from a list for convenient use.

• Resetting the settings for the Setup Menu

Settings for the Setup Menu can be reset to Factory Settings through the following operation:

- 1 Press and hold  over 1 second.

The Setup Menu appears.

- 2 Tap **[RESET/CLONE]**.

- 3 Tap **[1 FACTORY RESET]**.

- 4 Tap **[OK?]**.

Tapping **[Cancel]** cancels resetting.

- 5 The FTM-400DR reboots.

Setting content are reset and the FTM-400DR turns off once.

Shortly afterwards, the FTM-400DR automatically restarts.

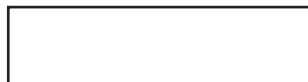

Setup Menu Operations List

Set Mode Number / Items	Function Description	Selectable Items (Bold Letter are Factory Setting Values)
DISPLAY		
1	DISPLAY SELECT Screen display setting for when  is pressed shortly.	NAVIGATION: ON / OFF TIMER/CLOCK: ON / OFF ALTITUDE: ON / OFF GPS INFORMATION: ON / OFF
2	BACKGROUND COLOR Setting for screen background color.	GREEN / BLUE / ORANGE / PURPLE / GRAY
3	BAND SCOPE Setting for screen display when SCOPE is executed. Setting for frequency bandwidth	NARROW / WIDE
4	LCD BRIGHTNESS Setting for LCD brightness	MIN / 2 / 3 / 4 / 5 / 6 / MAX
5	LCD CONTRAST Setting for LCD contrast	-3 / -2 / -1 / 0 / +1 / +2 / +3
6	TIME/VDD Setting for display content (Time/Voltage)	TIME / VDD
TX/RX		
1	MODE Reception mode switching	AUTO / FM / NARROW FM / AM
DIGITAL		
1	DIGITAL MODE	VOICE & DATA / FULL RATE (T.B.D.)

Setup Menu

Set Mode Number / Items	Function Description	Selectable Items (Bold Letter are Factory Setting Values)
TX/RX		
DIGITAL		
2	SQL TYPE	OFF / CODE / BREAK
3	SQL CODE	CODE: 001 to 126
4	PROFILE SEL	DIGITAL / APRS / GSMS
5	PROFILE (DIGITAL)	PROFILE: XXXXXXXXXX
6	DISTINATION MODE	CQ / CALLSIGN / GROUP
7	DISTINATION CALL	10 characters for each CALL1 to CALL8
8	POSITION DATA (VOICE)	ON / OFF
9	POSITION DATA (ONLY)	ON / OFF
AUDIO		
1	MIX/SEPARATE	Setting for Reception Audio MIX / SEPARATE
2	SUB BAND MUTE	Setting for Sub Band Mute OFF / ON (Mutes SUB BAND for both transmission and reception)
3	MIC GAIN	Adjustment for microphone Input MIN / LOW / NORMAL / HIGH / MAX
MEMORY		
1	MEMORY CH DISPLAY	Setting for memory channel display ALL / INBAND (ALL: Displays all memory channels INBAND: Only displays memory channels within BAND)
2	ALPHA TAG SIZE	Setting for the display size of memory channel tag SMALL / LARGE
3	MEM EDIT	Transitions to Memory Editor screen
4	MEM SCAN TYPE	Memory channel setting for when memory is scanned ALL MEM / SELECT MEM
SIGNALING		
1	TONE SQL FREQ	Setting for tone frequency 67Hz to 254.1Hz Default 88.5Hz
2	DCS CODE	Setting for DCS Code 023 to 754
3	AUTO DIALER	Setting for automatic transmission of DTMF Code OFF / ON
4	DTMF MEMORY	Registration of DTMF Code 1 to 9 channels 16 characters each
5	PAGER CODE	Setting for pager individual code RX CODE1 (05), CODE (47) TX CODE1 (05), CODE2 (47)
6	PRG REV TONE	300Hz to 3000Hz
7	BELL RINGER	Output setting for the Bell Function OFF / 1time / 3times / 5times / 8times / CONTINUOUS

Functions Used as Needed

Setup Menu

Set Mode Number / Items	Function Description	Selectable Items (Bold Letter are Factory Setting Values)
SIGNALING		
8	SQL EXPANTION Setting for separate Squelch Type in transmission and reception.	OFF / ON
9	WX ALERT	OFF / ON For USA models only
WIRES X		
1	DUAL WATCH STOP	AUTO / HOLD
2	SCAN DIRECTION	UP / DOWN
3	SCAN RESUME	BUSY / HOLD / 1sec / 3 sec / 5sec
CONFIG		
1	DATE & TIME ADJ Setting for the internal clock function of the FTM-400DR	Date 'xx-xx-xx (xxx) Time xx: xx
2	DATE & TIME FORMAT Setting for display format of the internal clock function	DATE: yyyy/mm/dd / yyyy/dd/mm / mm/dd/yyyy / dd/mm/yyyy TIME: 24 hour / 12 hour
3	TIME ZONE Setting for Time Zone	UTC±13h (0.5h Step) UTC+9:00 TOKYO
4	AUTO RPT SHIFT Setting for automatic repeater shift	OFF / ON
5	RPT SHIFT Setting for repeater shift direction	OFF / - / +
6	RPT SHIFT FREQ Setting for repeater shift width	0.00 - 99.95MHz This default setting is based on Band specification(50KHz step).
7	FM AM STEP Setting for channel step	AUTO / 5.00KHz / 6.25KHz / 8.33KHz / 9.00KHz / 10.00KHz / 12.50KHz / 15.00KHz / 20.00KHz / 25.00KHz / 50.00KHz / 100.00KHz / 200.00KHz
8	BEEP Setting for beep sound output	OFF / LOW / HIGH
9	CLOCK TYPE Setting for clock shift	A / B A: Clock shift operation AUTO B: Clock Clock shift operation forced ON
10	MIC PRG KEY Setting for P button on microphone	P1: OFF / BAND SCOPE / SCAN / HOME / DCS CODE / TONE FREQ / RPT SHIFT / REVERSE / TX POWER / SQL OFF / T-CALL (CE) / VOICE / WIRES / PRG FREQ or WX / S.LIST / MSG / REPLY / M.EDIT P2: OFF / BAND SCOPE / SCAN / HOME / DCS CODE / TONE FREQ / RPT SHIFT / REVERSE / TX POWER / SQL OFF / T-CALL / VOICE / WIRES / PRG FREQ or WX / S.LIST / MSG / REPLY / M.EDIT

Setup Menu

Set Mode Number / Items		Function Description	Selectable Items (Bold Letter are Factory Setting Values)
CONFIG			
10	MIC PRG KEY	Setting for P button on microphone	P3: OFF / BAND SCOPE / SCAN / HOME / DCS CODE / TONE FREQ / RPT SHIFT / REVERSE / TX POWER / SQL OFF / T-CALL / VOICE / WIRES / PR FREQ or WX / S.LIST / MSG / REPLY / M.EDIT P4: OFF / BAND SCOPE / SCAN / HOME / DCS CODE / TONE FREQ / RPT SHIFT / REVERSE / TX POWER / SQL OFF / T-CALL / VOICE / WIRES / PRG FREQ or WX / S.LIST / MSG / REPLY / M.EDIT
11	RX COVERAGE	Setting for bandwidth during Scope operation	NORMAL / WIDE (NORMAL: Displays Ham Band only WIDE: Displays all bands)
12	UNIT		METRIC / INCH
13	APO	Setting for APO operation time	OFF / 0.5 hour to 12.0 hour (0.5 hour Step)
14	TOT	Setting for Time Out timer	OFF / 5min to 30min (5min Step) depending on specification
15	BLUETOOTH PAIRING	Setting for DIAL operation of PIN Code	BLUETOOTH PAIRING: Select PIN Code with DIAL operation
16	GPS DATUM	Select a datum used for GPS Function	WGS-84 / TOKYO MEAN
17	GPS DEVICE		INTERNAL / EXTERNAL
18	GPS LOG	Setting for access time to GPS	ON / OFF 1 / 2 / 5 / 10 / 30 / 60 seconds
19	.X-BAND REPEATER		Execute .X-BAND REPEATER
DATA			
1	COM PORT SETTING	Setting for COM PORT	SPEED: 4800 / 9600 / 19200bps OUTPUT: OFF (camera) / GPS OUT / PACKET OUT / WAYPOINT INPUT: OFF / WP FORMAT: NMEA6 / NMEA7 / NMEA8 / NMEA9 WP FILTER: ALL / MOBILE / FREQ / OBJ/ITEM / DIGI / VOIP / WEATHER / YAESU / C RINGER / R RINGER
2	DATA BAND SELECT	Setting for band selection of APRS/DATA	APRS: MAIN BAND / SUB BAND / A-BAND FIX / B-BAND FIX / A=TX/R=RX / A=RX/R=TX DATA: MAIN BAND / SUB BAND / A-BAND FIX / B-BAND FIX / A=TX/R=RX / A=RX/R=TX
3	DATA SPEED	Setting for APRS/DATA transmission port rate	APRS: 1200 bps / 9600 bps DATA: 1200 bps / 9600 bps
4	DATA SQUELCH	Setting for digital repeater route	APRS: RX BAND / TX/RX BAND DATA: RX BAND / TX/RX BAND TX: ON / OFF

Functions Used as Needed

Setup Menu

Set Mode Number / Items	Function Description	Selectable Items (Bold Letter are Factory Setting Values)
APRS		
1	APRS COMPASS Operation Setting for APRS compass	NORTH UP / HEADING UP
2	APRS DISTINATION Display of Model Code	APY100 (Fixed)
3	APRS FILTER Setting for filter function	Mic-E: ON / OFF POSITION: ON / OFF WEATHER: ON / OFF OBJECT: ON / OFF ITEM: ON / OFF STATUS: ON / OFF OTHER: ON / OFF RANGE LIMIT: ON / OFF ALTNET: ON / OFF
4	APRS MODEM Setting for APRS port rate	OFF / ON
5	APRS MUTE ON/OFF setting for B Band AF Mute when setting the APRS	OFF / ON
6	APRS POP-UP Setting for Beacon type to display as Pop-Up	BEACON: OFF / 3 sec / 5 sec / 10 sec / HOLD MYPACKET: OFF / ON
7	APRS POP-UP COLOR Setting for background color of beacon that appears on Pop-up.	BEACON: OFF / LCD COLOR / WHITE-BLUE / SKY-BLUE / MARINE-BLUE / GREEN / YELLOW-GREEN / ORANGE / AMBER / WHITE MOBILE: OFF / LCD COLOR / WHITE-BLUE / SKY-BLUE / MARINE-BLUE / GREEN / YELLOW-GREEN / ORANGE / AMBER / WHITE OBJ/ITEM: OFF / LCD COLOR / WHITE-BLUE / SKY-BLUE / MARINE-BLUE / GREEN / YELLOW-GREEN / ORANGE / AMBER / WHITE CAL RING: OFF / LCD COLOR / WHITE-BLUE / SKY-BLUE / MARINE-BLUE / GREEN / YELLOW-GREEN / ORANGE / AMBER / WHITE RNG RING: OFF / LCD COLOR / WHITE-BLUE / SKY-BLUE / MARINE-BLUE / GREEN / YELLOW-GREEN / ORANGE / AMBER / WHITE MY PACKET: OFF / LCD COLOR / WHITE-BLUE / SKY-BLUE / MARINE-BLUE / GREEN / YELLOW-GREEN / ORANGE / AMBER / WHITE

Functions Used as Needed

Setup Menu

Set Mode Number / Items		Function Description	Selectable Items (Bold Letter are Factory Setting Values)
APRS			
8	APRS RINGER	Setting for bell sound for when there is a incoming beacon.	TX BEACON: ON / OFF RX BEACON: ON / OFF MY PACKET: ON / OFF CALL RINGER: ON / OFF RNG RINGER: 1-100 / OFF
9	APRS RINGER (CALL)	Call Sign setting for CALL RINGER	1 to 8 stations
10	APRS TXDELAY	Setting for the data delivery delay time	100ms / 150ms / 200ms / 250ms / 300ms / 400ms / 500ms / 750ms / 1000ms
11	APRS UNITS	Unit setting for APRS display	POSITION: mm/ss DISTANCE: km / mile SPEED: km/h / knot / mph ALTITUDE: m / ft BARO: hPa/mb/mmHg/inHg TEMP: °C / F RAIN: mm / inch WIND: m/s / mph / knot
12	BEACON INF SELECT	Setting for transmission beacon information	AMBIGUITY: OFF / 1-4digit SPD/CSE: ON / OFF ALTITUDE: ON / OFF
13	BEACON STATUS TXT	Input setting for Status Text	SELECT: TEXT1-5 / OFF TX RATE: 1/1 -1/8 1/2 (FREQ) - 1/8(FREQ), TEXT1-TEXT5
14	BEACON TX	Switching between automatic and manual transmission of beacon	AUTO: OFF / ON / SMART INTERVAL: 30sec-60min Default 5min PROPORTIONAL: ON / OFF DECAY: ON / OFF LOW SPEED: 1-99 (5km/h or 3mph) RATE LIMIT: 5-180sec Default 30sec
15	DIGI PATH SELECT	Setting for digital repeater route	OFF / WIDE1-1 / WIDE1-1.WIDE2-1 / PATH1-PATH4 / FULL1 / FULL2
16	DIGI PATH 1	Address setting for digital repeater route	ADDR1: ADDR2: No Input
17	DIGI PATH 2		ADDR1: ADDR2: No Input
18	DIGI PATH 3		ADDR1: ADDR2: No Input
19	DIGI PATH 4		ADDR1: ADDR2: No Input
20	DIGI PATH FULL 1		ADDR1: -ADDR8: No Input
21	DIGI PATH FULL 2		ADDR1: -ADDR8: No Input
22	PROFILE		xxxxxx-xx
23	MY POSITION SET	Position setting of your station	GPS / MANUAL / POINT MEM GR1-1to GR4-4
24	MY POSITION	Manual position setting of your station	Latitude: x xx°xx' xx" Longitude: x xxx°xx' xx"
25	MY SYMBOL	Setting for the symbol of your station	ICON1: [/>] Car / ICON2: [/R] REC.Vehicle / ICON3: [/-] House QTH (VHF) / USER: [YY] Yaesu Radios

Functions Used as Needed

Setup Menu

Set Mode Number / Items		Function Description	Selectable Items (Bold Letter are Factory Setting Values)
APRS			
26	POSITION COMMENT	Setting for position comments	Off Duty / En Route / In Service / Returnings / Committed / Special / Priority / Custom 0 to 6 / Emergency!
27	SmartBeaconing	Setting for Smart Beaconing	STATUS: OFF / TYPE1 / TYPE2 / TYPE3 LOW SPEED: 2-30 Default 5 HIGH SPEED: 3-70 Default 70 SLOW RATE: 1-100min Default 30min FAST RATE: 10-180 Default 120sec TURN ANGLE: 5-90° Default 28° TURN SLOPE: 1-255 Default 26 TURN TIME: 5-180sec Default 30sec
28	SORT FILTER	Setting for Sort Function and Filter Function	SORT: TIME / CALLSIGN / DISTANCE FILTER: ALL / MOBILE / FREQUENCY / OBJ/ITEM / DIGIPEATER / VOIP / WEATHER / YAESU / OTHER PKT / CALL RINGER / RNG RINGER / 1200bps / 9600bps
29	VOICE ALERT	Setting for Voice Alert Function	V.ALERT: NORMAL / TONE SQL / DCS / RX-TSQL / RX-DCS TSQL: 67.0Hz ~ 254.1Hz (Default 100.0Hz) DCS: DCS023 ~ DCS754 (Default DCS023)
OPTION			
1	BLUETOOTH	Setting for BLUETOOTH headset.	AUDIO: AUTO / FIX MODE: MIX / SEPARATE BATTERY: NORMAL / SAVE VOX: ON / OFF GAIN: HIGH / LOW
2	VOICE MEMORY	Setting for Voice Memory Function	PLAY/REC: FREE 5min / LAST30sec ANNOUNCE: AUTO / MANUAL LANGUAGE: JAPANESE / ENGLISH VOLUME: HIGH / MID / LOW
SD			
1	BACK UP		Write to SD / Read from SD / FORMAT: To selection screen
2	GROUP ID		Write to SD / Read from SD / FORMAT: To selection screen
RESET/CLONE			
1	FACTORY RESET	Reset all settings to Factory Settings	Resets all settings to Factory Settings (Was ALL RESET in past models). To confirmation screen.
2	PRESET	Registers Preset screen	Registration of Preset screen OK? / Cancel?
3	RECALL PRESET	Recalls Preset screen	Recall Preset screen OK? or Cancel?, after selecting from a list.



Functions Used as Needed

Setup Menu

	Set Mode Number / Items	Function Description	Selectable Items (Bold Letter are Factory Setting Values)
RESET/CLONE			
	4 MEM CH RESET	Erases memory channels	ALL MEM CH CLEAR: Only erases memory channels and keeps MENU content. To confirmation screen.
	5 MEM CH SORT	Sorts memory channels.	Sort A/B band memory channels. To confirmation screen.
	6 APRS RESET	Resets APRS settings.	Reset APRS settings. To confirmation screen.
	7 CLONE	Copies the setting content of your radio to other.	This radio → other (TX) / This radio ← other (RX) To selection screen

Apply settings to contents displayed on screen.

Setting content displayed on screen when  is pressed shortly.

- 1** Press and hold  over 1 second.
The Setup Menu appears.
- 2** Tap **[DISPLAY]**.
- 3** Tap **[1 DISPLAY SELECT]**.
The display settings for the screen appears.
- 4** Tap an item to display.
Select the screen to display from [NAVIGATION] [TIMER/CLOCK] [ALTITUDE] [GPS INFOR].
Tapping an item switches between [ON] and [OFF].
- 5** Set other screens.
Repeat Step 4 to set other screens.
- 6** Press and hold  over 1 second.
The displayed screen is set and the screen returns to the previous one.

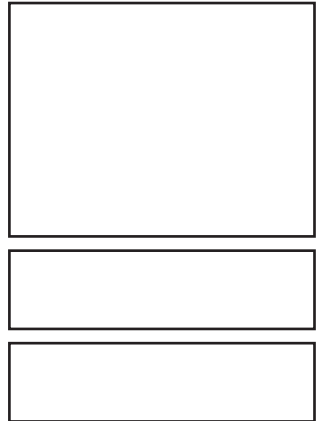

Reference • Factory Settings: All screens are set to [OFF].

Functions Used as Needed

Setup Menu

Setting the Background Color of the Screen

The background color for the screen can be selected from the following 5 colors:

- Green • Blue • Orange • Purple • Grey

1 Press and hold  over 1 second.

The Setup Menu appears.

2 Tap **[DISPLAY]**.

3 Tap **[2 BACKGROUND COLOR]** and select a background color.

The background color changes in the following order each time **[2 BACKGROUND COLOR]** is tapped.

[GREEN] → [BLUE] → [ORANGE] → [PURPLE] → [GRAY]

4 Press and hold  over 1 second.

The background color is set and the screen returns to the previous one.

Reference • Factory Settings: All screens are set to [GREEN].

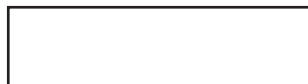

Setting the Frequency Width for Band Scope

The frequency band width to be displayed when Band Scope is operated can be set.

1 Press and hold  over 1 second.

The Setup Menu appears.

2 Tap **[DISPLAY]**.

3 Tap **[3 BAND SCOPE]** and select frequency band width.

Frequency band width switches between [NARROW] and [WIDE] each time **[3 BAND SCOPE]** is tapped.

NARROW: Frequency band width appears in a narrow search width.

WIDE: Frequency band width appears in a wide search width.

4 Press and hold  over 1 second.



The frequency band width is set and the screen returns to the previous one.

Reference • Factory Setting: [NARROW]



Adjusting the LCD Backlight Brightness Level

The brightness level of the LCD backlight can be adjusted.

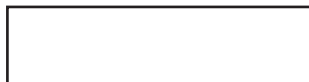

- 1 Press and hold  over 1 second.
The Setup Menu appears.
- 2 Tap [DISPLAY].
- 3 Tap [4 LCD BRICHTNESS].
The LCD Brightness Setting screen appears.
- 4 Tap [-] or [+] to adjust brightness.
Select the brightness from [MIN], [2], [3], [4], [5], [6], and [MAX].
The selected brightness can be confirmed on screen.
- 5 Press and hold  over 1 second.
The LCD Brightness is set and the screen returns to the previous one.

Reference • Factory Setting: [MAX]



Adjusting LCD Contrast

The contrast level of the screen can be adjusted.

- 1 Press and hold  over 1 second.
The Setup Menu appears.
- 2 Tap [DISPLAY].
- 3 Tap [5 LCD CONTRAST].
The LCD Contrast Setting screen appears.
- 4 Tap [-] or [+] to adjust contrast.
Select the contrast from [-3], [-2], [-1], [0], [+1], [+2], and [+3].
The selected contrast can be confirmed on screen.
- 5 Press and hold  over 1 second.
The LCD contrast level is set the screen returns to the previous one.

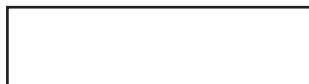

Reference • Factory Setting: [0]



Setup Menu

Switching between Time and Voltage display

The display on the top right of the screen can be switched between [Time Display] and [Voltage Display].



- 1 Press and hold  over 1 second.
The Setup Menu appears.
- 2 Tap [DISPLAY].
- 3 Tap [6 TIME/VDD] and select the display content.
The display switches between [TIME] and [VDD] every time [6 TIME/VDD].
TIME: The Time appears.
VDD: The voltage appears.
- 4 Press and hold  over 1 second.
The display content is set and the screen returns to the previous one.



Reference • Factory Setting: [TIME]

Adjusting volume respectively to A/B Bands

The volume for A Band and B Band can be separately adjusted. Additionally, if your radio is connected to external speakers, the A/B Band Audio can be separated to left and right speakers.

- 1 Press and hold  over 1 second.
The Setup Menu appears.
- 2 Tap [TX/RX].
- 3 Tap [AUDIO].
- 4 Tap [1 MIX/ SEPERATE] and select ***.
Audio is switched between [MIX] and [SEPERATE] each time [1 MIX/SEPERATE] is tapped.
MIX: Simultaneously adjust volume for A Band and B Band.
SEPERATE: Separately adjust volume for A Band and B Band.
- 5 Press and hold  over 1 second.
The selected volume adjustment is set and the screen returns to the previous one.

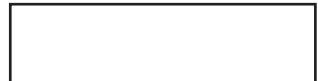



Reference • Factory Setting: [MIX]

Setup Menu

Setting the Display Method for Memory Channels

The display method for registered memory channels can be selected from the following 2 methods:

- ALL: Displays all registered memory channels
- INBAND: Only displays memory channels within the band currently in use.

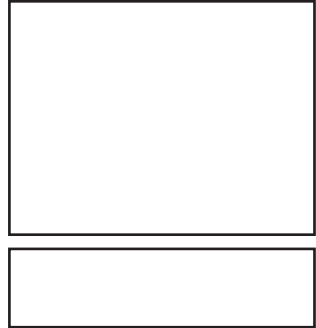

- 1** Press and hold  over 1 second.
The Setup Menu appears.
- 2** Tap **[MEMORY]**.
- 3** Tap **[1 MEMORY CH DISPLAY]** and set the memory channels to display.
Tapping **[1 MEMORY CH DISPLAY]** will switch between **[ALL]** and **[INBAND]**.
- 4** Press and hold  over 1 second.
The display method for memory channels is set and the screen returns to the previous one.



Reference • Factory Setting: [ALL]

Setting the Squelch Type for transmission

Preset squelch types can be used separately for transmission and reception.

- 1** Press and hold  over 1 second.
The Setup Menu appears.
- 2** Tap **[SIGNALING]**.
- 3** Tap **[8 SQL EXPANSION]** and select between OFF/ ON.
Tapping **[8 SQL EXPANSION]** switches between **[ON]** and **[OFF]**.
OFF: Use the same squelch type for transmission and reception.
ON: Use separate squelch type for transmission and reception.
- 4** Press and hold  over 1 second.
The squelch type for transmission and reception is set and the screen returns to the previous one.

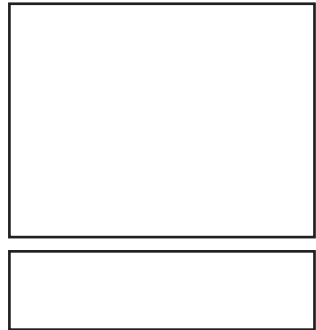

Reference • Factory Setting: [OFF]



Functions Used as Needed

Setup Menu

Setting the display format for the Clock Function

The display format for the internal clock can be chosen from the following types:

- Date Display: Month/Day/Year, Year/Month/Day, Day/Month/Year, Year/Day/Month
- Time Display: 24 Hour Display, 12 Hour Display

- 1 Press and hold  over 1 second.
The Setup Menu appears.
- 2 Tap **[CONFIG]**.
- 3 Tap **[2 DATA & TIME FORMAT]**.
The setting screen for date and time display appears.
- 4 Tap **[DATE]**.
The setting screen for date display format appears.
- 5 Tap format to be displayed.
Select the display format for the Date.
mmm/dd/yyyy: Date appears as Month/Day/Year
yyy/mmm/dd: Date appears as Year/Month/Day
dd/mmm/yyyy: Date appears as Day/Month/Year
yyy/dd/mmm: Date appears as Year/Day/Month
- 6 Tap **[BACK]**.
- 7 Tap **[TIME]** and select the display format for time.
Tapping **[TIME]** switches between [24 hour] and [12 hour].
- 8 Press and hold  over 1 second.
The Time and Date display format is set and the screen returns to the previous one.







Reference • Factory Setting: Date Display Format mm/dd/yyyy,
Date Display Format 24 hour

Setting the Time Zone

The internal clock can be set to time data from GPS (Coordinated Universal Time). On Factory Settings the internal clock is set to Japan Time (UTC+9:00 TOKYO) and does not need to be adjusted.



The time zone can be adjusted in 0.5 hour units for up to ±13 hours.

- 1 Press and hold  over 1 second.
The Setup Menu appears.
- 2 Tap **[CONFIG]**.
- 3 Tap **[3 TIME ZONE]**.
The time zone appears in orange.
- 4 Turn the  to adjust the time zone.
Rotate the  and select the desired time zone for a overseas city.
The time zone can be adjusted in 0.5 hour units for up to ±13 hours.
- 5 Press  shortly.
The time zone is set and displayed in green.
- 6 Press and hold  over 1 second.
Returns to the previous screen.

Reference • Factory Setting: UTC+9:00 TOKYO

Setting the Automatic Repeater Shift

When using the repeater for communication, the automatic repeater shift function that automatically starts communication via the repeater can be set to ON/OFF.

- 1 Press and hold  over 1 second.
The Setup Menu appears.
- 2 Tap **[CONFIG]**.
- 3 Tap **[4 AUTO RPT SHIFT]** and select between ON/OFF.
Tapping **[4 AUTO RPT SHIFT]** switches between [ON] and [OFF].
ON: Automatically starts communication using repeater shift.
OFF: Manually select tone frequency and start communication
- 4 Press and hold  over 1 second.



The automatic repeater shift is set and the screen returns to the previous one.

Reference • Factory Setting: ON

Setup Menu

Setting the Clock Shift of the Microcomputer

You can set microcomputer clock signal so as not to receive as internal spurious by high frequency. Select [A] for normal time usage.



- 1 Press and hold  over 1 second.
The Setup Menu appears.
- 2 Tap [CONFIG].
- 3 Tap [9 CLOCK TYPE] and set A/B.
Tapping [9 CLOCK TYPE] switches between [A] and [B].
A: The clock shift function automatically switches between ON and OFF.
B: The clock shift function is active at all times.
- 4 Press and hold  over 1 second.
The clock type is set and the screen returns to the previous one.



Reference • Factory Setting: A

Setting the Program Keys on the Microphone

Assign functions to the program keys (P1 to P4) on the accessory microphone (MH-48).

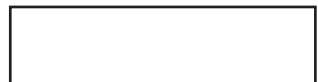

- 1 Press and hold  over 1 second.
The Setup Menu appears.
- 2 Tap [CONFIG].
- 3 Tap [10 MIC PRG KEY].
The Microphone Program Keys setting screen appears.
- 4 Tap the Program key you would like to set.
Tap the Program Key (P1 to P4) you would like to assign a function.
The functions that can be assigned are displayed.
If the function you would like to assign is not displayed, scroll the screen with [▲] and [▼].
- 5 Tap the function you would like to assign.
The function to assign to the program key is selected.
- 6 Tap [BACK].
The screen returns to the program key (P1 to P4) selection.
- 7 Set functions for the other program keys.
Repeat steps 4 to 6 and assign functions to other function keys.
- 8 Press and hold  over 1 second.
The function is assigned to the program key and returns to the previous screen.



Reference • Factory Setting: P1: SQL OFF P2: HOME P3: RPT SHIFT P4: TX POWER

Setting the Bandwidth to Scope

The Bandwidth for when scoping in VFO mode or Memory mode can be set.



- 1 Press and hold  over 1 second.
The Setup Menu appears.
- 2 Tap **[CONFIG]**.
- 3 Tap **[11 RX COVERAGE]** to select NORMAL/WIDE.
Tapping **[11 RX COVERAGE]** switches between [NORMAL] and [WIDE].
NORMAL: Scopes Ham Band only.
WIDE: Scopes all Bands.
- 4 Press and hold  over 1 second.
The bandwidth to scope is set and the screen returns to the previous one.



Reference • Factory Setting: NORMAL

Setting the unit of measurement to be displayed

The unit of measurement can be set for displaying altitude, distance, and speed.

- 1 Press and hold  over 1 second.
The Setup Menu appears.
- 2 Tap **[CONFIG]**.
- 3 Tap **[12 UNIT]** and select METRIC/INCH.
Tapping **[12 UNIT]** switches between [METRIC] and [INCH].
METRIC: The unit of measurement appears in metric.
INCH: The unit of measurement appears in inch.
- 4 Press and hold  over 1 second.
The unit of measurement is set and the screen returns to the previous one.

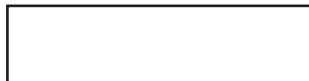

Reference • Factory Setting: METRIC

Setup Menu

Automatically Turning Off the Power **APO** Function

The FTM-400DR can be set so that it turns off automatically if you do not operate it for a certain period of time. You can change the time until the FTM-400DR is turned off automatically Use this function after setting the clock, referring to [Setting the Clock (See page 21)].

- 1 Press and hold  over 1 second.

The Setup Menu appears.

- 2 Tap **[CONFIG]**.

- 3 Tap **[13 APO]**.

The APO setting screen appears.

- 4 Tap **[-]** or **[+]** to adjust the time.

Specify the time until the FTM-400DR is turned off automatically in steps of 30 minutes.

OFF / 30 min / 1 hour to 12 hours

- 5 Press and hold  over 1 second.

The Auto Power Off function is set and the screen returns to the previous one.

Reference • Factory Setting: OFF



Restricting the Continuous Transmission Time **TOT** Function

The FTM-400DR can be set that it automatically returns to reception state after performing continuous transmission for a certain period of time. Accidental transmission of unnecessary radio waves and unwanted battery power consumption can be prevented (time-out timer function).

- 1 Press and hold  over 1 second.

The Setup Menu appears.

- 2 Tap **[CONFIG]**.

- 3 Tap **[14 TOT]**.

The time display for TOT appears in orange.

- 4 Turn the  to set the time.

Turn the  to set the Time Out time in steps of 5 minutes.

OFF / 5 min to 30 min

- 5 Press  shortly.

The time is set and displayed in green.

- 6 Press and hold  over 1 second.

Returns to the previous screen.

Reference • Factory Setting: 5 min

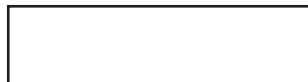



Setting PIN Code for a BLUETOOTH headset

Using a BLUETOOTH headset requires setting its PIN code to the FTM-400DR.

Reference

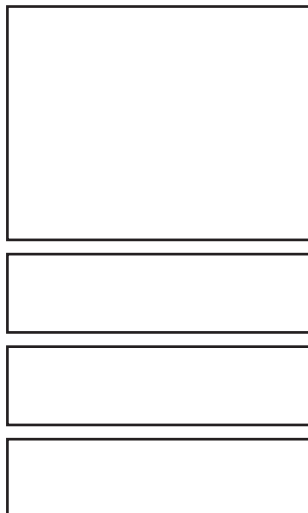

- The PIN code for a BLUETOOTH headset from our company is 6111. If the BLUETOOTH headset is not from our company, check the PIN code by referring to the instruction manual for that product.

- 1 Press and hold  over 1 second.
The Setup Menu appears.
- 2 Tap **[CONFIG]**.
- 3 Tap **[15 BLUETOOTH PAIRING]**.
PIN code input screen appears
- 4 Tap the numeric keys to input the PIN code.
By tapping the numbers displayed on screen, input the 4 digit code.
Reference • Tap **[Cancel]** if incorrect number is entered.
- 5 Tap **[ENT]**.
The PIN code is set.
- 6 Press and hold  over 1 second.
Returns to the previous screen.
Reference • Factory Setting: 6111



Selecting Datum for GPS function.

Select a datum used for the GPS function.

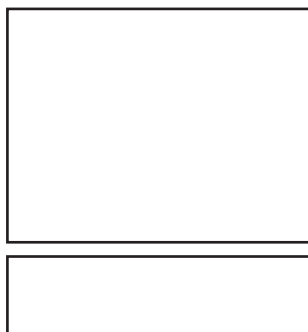

- 1 Press and hold  over 1 second.
The Setup Menu appears.
- 2 Tap **[CONFIG]**.
- 3 Tap **[16 GPS DATUM]** to set a datum.
Tapping **[16 GPS DATUM]** switches between **[TOKYO MEAN]** and **[WGS 84]**.
WGS-84: The standard setting for worldwide standard. Select WGS-84 under normal operation.
TOKYO MEAN: Enables reducing the error in positioning when using GPS in Japan (Tokyo)
- 4 Press and hold  over 1 second.
The datum for GPS is set and the screen returns to the previous one.



Setup Menu

Setting the GPS Device to Use



Before using the GPS function, select whether to use the internal GPS function of the FTM-400DR or a connected external GPS device.

- 1 Press and hold  over 1 second.
The Setup Menu appears.
- 2 Tap **[CONFIG]**.
- 3 Tap **[17 GPS DEVICE]** and set the GPS device.
Tapping **[17 GPS DEVICE]** switches between **[INTERNAL]** and **[EXTERNAL]**.
INTERNAL: Use the internal GPS function of the FTM-400DR.
EXTERNAL: Use the connected external GPS device.
- 4 Press and hold  over 1 second.
The GPS function (or device) is set and the screen returns to the previous one.
Reference • Factory Setting: INTERNAL



Setting Time for Accessing GPS

The time for accessing GPS for receiving signals and information can be set.

- 1 Press and hold  over 1 second.
The Setup Menu appears.
- 2 Tap **[CONFIG]**.
- 3 Tap **[18 GPS LOG]**.
The GPS LOG Time Setting screen appears.
- 4 Tap **[-]** or **[+]** to set the time.
Set the time that the FTM-400DR accesses GPS.
The FTM-400DR does not access GPS if **[OFF]** is tapped.
OFF/1 sec/2 sec/5 sec/10 sec/30 sec/60 sec
- 5 Press and hold  over 1 second.
The access time to GPS is set and the screen returns to the previous one.
Reference • Factory Setting: 10 sec (when GPS antenna connected)
OFF (when GPS antenna unconnected)





Setup Menu

Communicating by crossing A Band and B band frequencies

Audio can be transmitted with B Band (430MHz band) while receiving it with A Band (144MHz band).

Similarly, audio can be transmitted with A Band while receiving it with B Band.

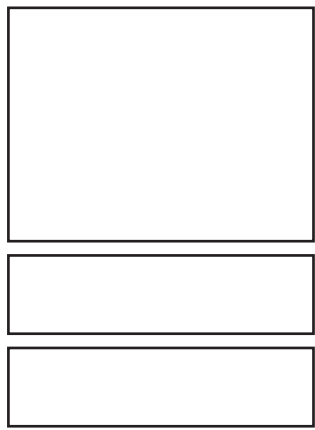

- 1 Press and hold  over 1 second.
The Setup Menu appears.
- 2 Tap **[CONFIG]**.
- 3 Tap **[19 X-BAND REPEATER]**.
The X-BAND REPEATER confirmation screen appears.
- 4 Tap **[OK?]**.
X-BAND REPEATER is activated.
To deactivate it, tap **[Cancel]**.
- 5 Press and hold  over 1 second.
Returns to the previous screen.



Reference • Factory Setting: OFF

Setting USB Camera to Use.

The FTM-400DR can capture images and video by connecting a USB camera and transmit/ receive them. You can set the picture size and quality for the USB camera you are going to use.

- 1 Press and hold  over 1 second.
The Setup Menu appears.
- 2 Tap **[OPTION]**.
- 3 Tap **[1 USB CAMERA]**.
The USB CAMERA setting screen appears.
 - PICTURE SIZE: Set the picture size you will capture.
 - PICTURE QUALITY: Set the image quality you will capture.
- 4 Tap **[PICTURE SIZE]** to set the picture size.
Tapping **[PICTURE SIZE]** switches between [160 × 1120] and [320 × 240].
- 5 Tap **[PICTURE QUALITY]** to set the picture quality.
Tapping **[PICTURE QUALITY]** switches between [NORMAL] and [HIGH].
- 6 Press and hold  over 1 second.
The picture settings for the USB Camera are set and the screen returns to the previous one.

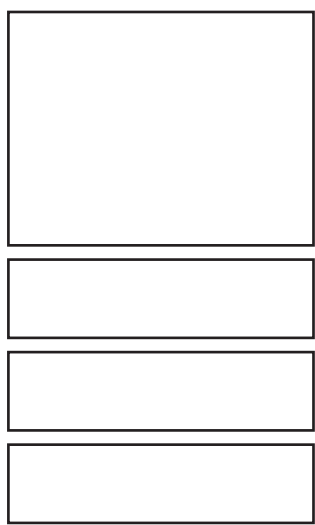

Functions Used as Needed

Setup Menu

Setting operations of BLUETOOTH Headset to Use

You can set operations of the BLUETOOTH headset connected to the FTM-400DR. Setting content are as follows:

- AUDIO: Set the audio output operation of the BLUETOOTH headset.
- BATTERY: Set the battery of the BLUETOOTH headset.
- VOX: Set the switching operation of the BLUETOOTH headset.
- GAIN: Set the VOX sensitivity of the BLUETOOTH headset.

1 Press and hold  over 1 second.

The Setup Menu appears.

2 Tap [OPTION].

3 Tap [2 BLUETOOTH].

The BLUETOOTH Setting screen appears.

4 Tap [AUDIO] to set the audio output operation of the headset.

Tapping [AUDIO] switches between [AUTO] and [FIX].

- AUTO: When the BLUETOOTH headset is connected, the audio is only heard through the headset.
- FIX: When the BLUETOOTH headset is connected, the audio is heard from both speakers and headset.

5 Tap [BATTERY] to set the battery usage condition of the headset.

Tapping [BATTERY] switches between [NORMAL] and [SAVE].

- NORMAL: The battery save function for the BLUETOOTH headset is set to OFF.
- SAVE: The battery save function for the BLUETOOTH headset is set to ON.

6 Tap [VOX] to enable or disable the transmission and reception switching on the headset.

Tapping [VOX] switches between [OFF] and [ON].

- OFF: Transmission and reception cannot be switched on the BLUETOOTH headset.
- ON: Transmission and reception can be switched on the BLUETOOTH headset.

Reference • Selecting [ON] displays the option for selecting [GAIN].

7 Tap [GAIN] to set the VOX sensitivity.

Tapping [GAIN] switches between [HIGH] and [LOW].

- HIGT: The VOX sensitivity for the BLUETOOTH headset is set to high.
- LOW: The VOX sensitivity for the BLUETOOTH headset is set to low.

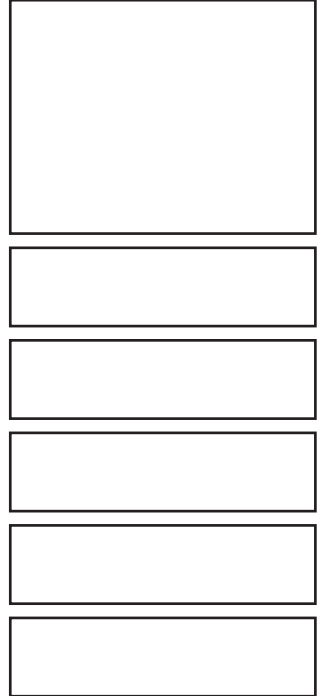

Setup Menu

- 8 Press and hold  over 1 second.
 The BLUETOOTH is set and the screen returns to the previous one.

Reference • Factory Setting: AUDIO: AUTO
 BATTERY: NORMAL
 VOX: OFF
 GAIN: HIGH

Setting Operations of the Voice Announcement Function

You can set the operations of the Voice Announcement function equipped to the FTM-400DR.

Setting content are as follows:

- PLAY/REC: Set conditions for Record/Play.
- ANNOUNCE: Set conditions for the Voice Announcement of frequency.
- LANGUAGE: Set the language to use for the Voice Announcement.
- VOLUME: Set the volume of the Voice Announcement.

- 1 Press and hold  over 1 second.
 The Setup Menu appears.
- 2 Tap **[OPTION]**.
- 3 Tap **[3 VOICE MEMORY]**.
 The VOICE MEMORY setting screen appears.
- 4 Tap **[PLAY/REC]** to set the Record/Play time.
 Tapping **[PLAY/REC]** switches between **[FREE5min]** and **[LAST30sec]**.
 - FREE5min: With 8 recording areas, the total of 5 minutes can be recorded.
 - LAST30sec: Records the last 30 seconds before **[■ STOP]** is pressed.
- 5 Tap **[ANNOUNCE]** to set the Voice Announcement of frequency.
 Tapping **[ANNOUNCE]** switches between **[AUTO]**, **[OFF]**, and **[MANUAL]**.
 - AUTO: The frequency is announced by voice when **[VOICE]** is tapped or Band is changed.
 - OFF: The frequency is not announced by voice.
 - MANUAL: The frequency is announced by voice when **[VOICE]** is tapped.

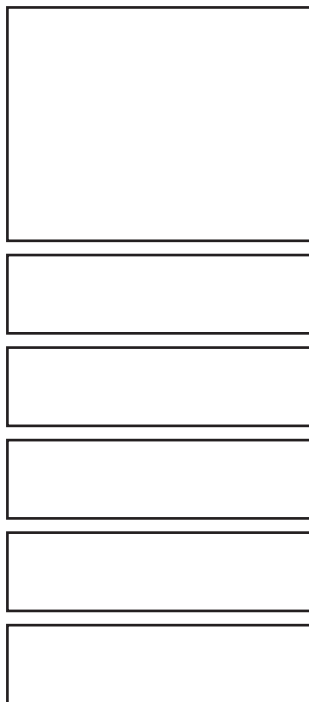

Functions Used as Needed

Setup Menu



- 6 Tap **[LANGUAGE]** to set the language for the Voice Announcement.
 Tapping **[LANGUAGE]** switches between **[JAPANESE]** and **[ENGLISH]**.
 - **JAPANESE**: Announces the frequency in Japanese.
 - **ENGLISH**: Announces the frequency in English.
- 7 Tap **[VOLUME]** to set the volume of Voice Announcement.
 Tapping **[VOLUME]** switches among **[HIGH]**, **[MID]**, and **[LOW]**.
 - **HIGH**: The volume of Voice Announcement is set to **[HIGH]**.
 - **MID**: The volume of Voice Announcement is set to **[MEDIUM]**.
 - **LOW**: The volume of Voice Announcement is set to **[LOW]**.
- 8 Press and hold  over 1 second.
 The settings for the Voice Announcement Function are set and the screen returns to the previous one.

Reference • Factory Setting: PLAY/REC: FREE 5 min
 ANNOUNCE: AUTO
 LANGUAGE: JAPANESE
 VOLUME: HIGH

Writing Group ID to microSD Memory Card

Group ID information registered to the FTM-400DR can be written to microSD memory card.

Additionally, Group ID information saved to the microSD memory card can be read to the internal memory of the FTM-400DR.

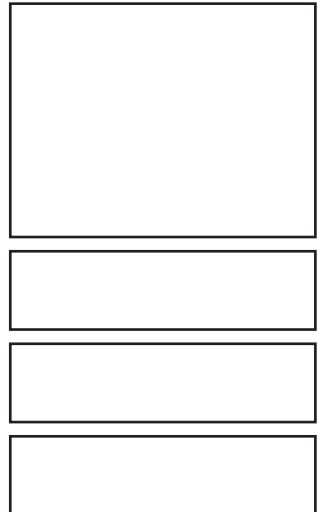

- 1 Press and hold  over 1 second.
 The Setup Menu appears.
- 2 Tap **[SD]**.
- 3 Tap **[2 GROUP ID]**.
 The GROUP ID Selection screen appears.
- 4 Tap an item to select.
 Tap each item to select.
 - **Write to SD**: Write group ID information registered to the FTM-400DR to microSD memory card.
 - **Read to SD**: Read and register Group IDs saved to the microSD memory card to FTM-400DR.
 - **FORMAT**: Format the microSD memory card.
- 5 Tap **[OK?]**.
 The selected items are activated.
 To cancel the operation, tap **[Cancel]**.
- 6 Press and hold  over 1 second.
 Returns to the previous screen.

Reference • Factory Setting: FORMAT



Registering Preset

Only one current setting, such as frequency or memory channel can be registered to Preset.

- 1 Press and hold  over 1 second.
The Setup Menu appears.
- 2 Tap **[RESET/CLONE]**.
- 3 Tap **[2 PRESET]**.
The Preset registration confirmation screen appears.
- 4 Tap **[OK?]**.
The PRESET screen is registered.
To cancel the registration, tap **[Cancel]**.
- 5 Press and hold  over 1 second.
Returns to the previous screen.

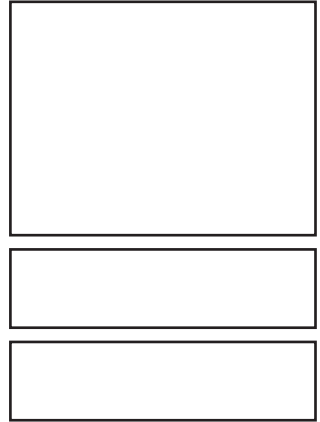

Recalling the Registered Preset

The registered Preset screen can be recalled from the Setup Menu.

- 1 Press and hold  over 1 second.
The Setup Menu appears.
- 2 Tap **[RESET/CLONE]**.
- 3 Tap **[3 RECALL PRESET]**.
The list of registered Preset screens appears.
- 4 Tap the Preset screen to recall.
Tap the Preset screen to recall from the list of Preset screens.
The screen registered to Preset appears on screen.
To cancel recalling, tap **[Cancel]**.

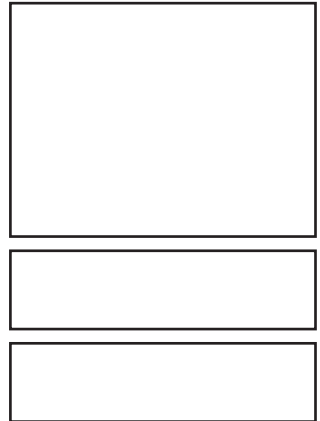



Setup Menu

Deleting Memory Channels

You can delete only registered memory channels. Information besides memory channel, such as menu content or setting items, cannot be deleted.

Reference

- To reset all settings and information to Factory Settings, tap **[RESET/CLONE]** and then **[1 FACTORY RESET]**. Doing so resets all registered information to default settings.

- 1 Press and hold  over 1 second.
The Setup Menu appears.
- 2 Tap **[RESET/CLONE]**.
- 3 Tap **[4 MEM CH RESET]**.
The memory channel deletion confirmation screen appears.
- 4 Tap **[OK?]**.
All memory channels are deleted.
To cancel deletion, tap **[Cancel]**.
- 5 Press and hold  over 1 second.
Returns to the previous screen.

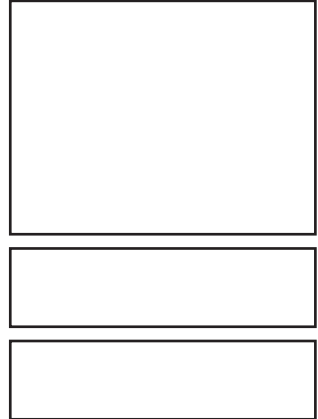

Sorting Registered Memory Channels in Order.

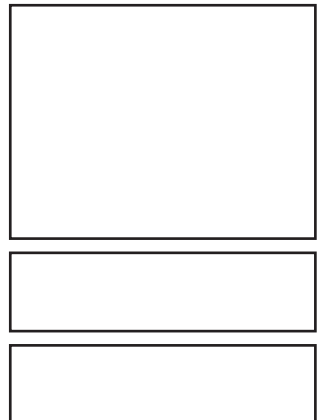

You can sort the registered memory channels in order.

- 1 Press and hold  over 1 second.
The Setup Menu appears.
- 2 Tap **[RESET/CLONE]**.
- 3 Tap **[5 MEM CH SORT]**.
- 4 Tap **[OK?]**.
The memory channels are sorted in order of lowest frequency.
To cancel sorting, tap **[Cancel]**.
- 5 The FTM-400DR restarts_.
The FTM-400DR turns off once, then restarts automatically.



Deleting Settings Configured for APRS Function.

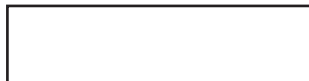

You can delete all information for settings configured for the APRS function.

- 1 Press and hold  over 1 second.
The Setup Menu appears.
- 2 Tap **[RESET/CLONE]**.
- 3 Tap **[6 APRS RESET]**.
The deletion confirmation screen appears.
- 4 Tap **[OK?]**.
Settings information for the APRS Function are deleted.
To cancel deletion, tap **[Cancel]**.
- 5 Press and hold  over 1 second.
Returns to the previous screen.



The Clone Function For copying settings to another FTM-400DR

Information registered to this FTM-400DR can be copied to other FTM-400DR. Additionally, information registered to other FTM-400DR can be copied to this FTM-400DR.

- 1 Turn off the FTM-400DR and connect the Clone Cable.
Connect this FTM-400DR with another FTM-400DR with the Clone Cable.
- 2 Press .
- 3 Press and hold  over 1 second.
- 4 Tap **[RESET/CLONE]**.
- 5 Tap **[7 CLONE]**.
- 6 Tap **[This radio → other (X)]** for the sending FTM-400DR (copy source).
Tap **[This radio ← other (X)]** for the receiving FTM-400DR (copy destination).
- 7 Tap **[OK?]**.
Copying (Cloning) starts.
To cancel Cloning, tap **[Cancel]**.
Once copying (Cloning) is complete, **[COMPLETE]** appears on screen.
- 8 Turn off the power of FTM-400DR and disconnect the cable.

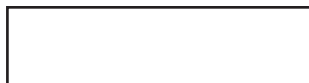
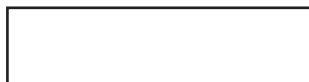

Setup Menu

Reference

- If [ERROR] appears while copying (Cloning), check the connection of the Clone cable and restart the operation from the beginning.
- If copying (Cloning) is abnormally aborted due to power failure, the receiving FTM-400DR will be automatically reset all information. Check that there are no abnormalities with the power and restart operation from the beginning.

General

Frequency Range:	RX: 108 - 137 MHz, 137 - 174 MHz, 174 - 222 MHz, 222 - 420 MHz, 420 - 470 MHz, 800 - 999 MHz (Cellular Blocked)
	TX: 144 - 148 MHz, 430 - 450 MHz
Channel Steps:	5/6.25/10/12.5/15/20/25/50/100 kHz
Mode of Emission:	F1D, F2D, F3E, F7W
Antenna Impedance:	50 Ω , unbalanced
Frequency Stability:	± 2.5 ppm (-20 $^{\circ}$ C to $+60$ $^{\circ}$ C)
Operating Temperature Range:	-20 $^{\circ}$ C to $+60$ $^{\circ}$ C
Supply Voltage:	11 - 16 V DC (Negative Ground)
Current Consumption (Approx.):	
	RX: 500 mA (Analog) 600 mA (Digital)
	TX: 9.4 A (144 MHz / Analog) 9.5 A (144 MHz / Digital) 10.2 A (430 MHz / Analog) 10.3 A (430 MHz / Digital)
Case Size (W \times H \times D):	
	Panel: 140(W) \times 72(H) \times 20(D) mm (w/o knob & connectors)
	Rear Chassis: 140(W) \times 40(H) \times 125(D) mm (w/o connectors)
Weight (Approx.):	1150g (Panel + Rear Chassis + Connection Cable)

Transmitter

Output Power:	50 W (144 / 430 MHz), 20 W (144 / 430MHz) 5 W (144 / 430 MHz)
Modulation Type:	Variable Reactance
Maximum Deviation:	± 5 KHz,
Spurious Radiation:	better than -60 dB
Modulation Distortion:	less than 3%
Microphone Impedance:	2 k Ω

Receiver

Circuit Type:	Double-conversion super heterodyne (N-FM / AM)
Intermediate Frequency:	1st: A- Band 47.25 MHz (N-FM / AM) 1st: B- Band 44.85 MHz (N-FM / AM) 2nd: 450 kHz (N-FM / AM)

FTM-400DR Specifications

Sensitivity (for 12dB SINAD):	108 - 137 MHz: 0.80 μV	(10 dB S/N, AM)
	137 - 140 MHz: 0.20 μV	(12 dB SINAD, N-FM)
	140 - 150 MHz: 0.16 μV	(12 dB SINAD, N-FM)
	150 - 174 MHz: 0.25 μV	(12 dB SINAD, N-FM)
	174 - 300 MHz: 0.80 μV	(12 dB SINAD, N-FM)
	300 - 336 MHz: 0.80 μV	(10 dB S/N, AM)
	336 - 420 MHz: 0.25 μV	(12 dB SINAD, N-FM)
	420 - 470 MHz: 0.16 μV	(12 dB SINAD, N-FM)
	470 - 540 MHz: 0.30 μV	(12 dB SINAD, N-FM)
	540 - 800 MHz: 0.80 μV	(12 dB SINAD, N-FM)
800 - 999 MHz: 0.80 μV	(12 dB SINAD, N-FM)	
	(USA Version Cellular Blocked)	
Selectivity (-6dB/-60dB):	12 kHz / 30 kHz (N-FM/AM)	
Maximum AF Output:	4 W @ 13.8V, 10% THD (EXP SP)	
AF Output Impedance:	4 - 16 Ω	

1. Changes or modifications to this device not expressly approved by YAESU MUSEN could void the user's authorization to operate this device.
2. This device complies with part 15 of the FCC Rules. Operation is subject to the following two conditions; (1) this device may not cause harmful interference, and (2) this device must accept any interference including interference that may cause undesired operation.
3. The scanning receiver in this equipment is incapable of tuning, or readily being altered, by the User to operate within the frequency bands allocated to the Domestic public Cellular Telecommunications Service in Part 22.

Part 15.21: Changes or modifications to this device not expressly approved by YAESU MUSEN could void the user's authorization to operate this device.

DECLARATION BY MANUFACTURER

The Scanner receiver is not a digital scanner and is incapable of being converted or modified to a digital scanner receiver by any user.

WARNING: MODIFICATION OF THIS DEVICE TO RECEIVE CELLULAR RADIOTELEPHONE SERVICE SIGNALS IS PROHIBITED UNDER FCC RULES AND FEDERAL LAW.

YAESU
The radio

Copyright 2012
YAESU MUSEN CO., LTD.
All rights reserved.

No portion of this manual
may be reproduced
without the permission of
YAESU MUSEN CO., LTD.

Printed in Japan