

STANDARD HORIZON

Nothing takes to water like Standard Horizon

MATRIX

GX2200

25 Watt VHF/FM

Marine Transceivers

Owner's Manual

- Integrated dual channel AIS (Automatic Identification System) receiver
- Integrated 12 Channel WAAS GPS receiver
- GPS antenna built-in to the front panel allows reception when bracket or flush mounted
- 4800 or 38400 NMEA baud rate selection for plotters with 1 NMEA port
- Able to use PA or Fog signaling when on AIS display
- True and Magnetic bearing selection on AIS display
- AIS target display includes MMSI, Callsign, Ship Name, BRG, DST, SOG & COG
- Contact Class A or B AIS Ship with DSC
- Programmable CPA or TCPA collision avoidance alarms
- ITU Class D DSC (Independent Channel 70 receiver built-in)
- Navigation information (LAT/LONG, SOG, COG) information shown on display
- Navigate to a DSC Distress Position
- Enter, Save and Navigate to a waypoint with compass page
- 80dB commercial grade receiver
- Automatic DSC Position Poll request to up to 4 separate vessels
- E2O (Easy to operate) menu system with user programmable soft keys on radio
- GPS Compass, Waypoint and GPS status pages
- Submersible JIS-7/IPX-7 rating (3.3 feet for 30 mins)
- 30 Watt PA/Loudhailer with pre programmed fog signals and listen-back facility
- ClearVoice noise cancelling microphone with channel selector and 16/9 key
- Capable of connecting to a Second Station Remote-Access Microphone CMP30
- Intercom between radio and RAM3 microphone
- Versatile user-programmable scanning, priority scan and Dual Watch
- Oversized rotary CH knob with push to enter, backlit display and keys
- Voice Scrambler (optional)
- Local/Distance attenuator



TABLE OF CONTENTS





Quick Reference Guide.....	4	8.11.3 Fog Signal Timing Chart.....	44
1 GENERAL INFORMATION.....	5	8.12 INTERCOM OPERATION.....	45
2 PACKING LIST.....	6	8.12.1 Communication.....	45
3 OPTIONAL ACCESSORIES.....	6	8.12.2 Calling.....	45
4 ONLINE WARRANTY REGISTRATION (in USA or Canada only).....	6	8.13 VOICE SCRAMBLER.....	46
5 GETTING STARTED.....	7	8.14 DEMO MODE.....	47
5.1 PROHIBITED COMMUNICATIONS.....	7	9 DIGITAL SELECTIVE CALLING (DSC).....	48
5.2 ABOUT VHF RADIO.....	7	9.1 GENERAL.....	48
5.3 SELECTING AN ANTENNA.....	7	9.2 MARITIME MOBILE SERVICE IDENTITY (MMSI).....	48
5.4 COAXIAL CABLE.....	8	9.2.1 What is an MMSI?.....	48
5.5 DISTRESS AND HAILING (CHANNEL 16).....	8	9.2.2 Programming the MMSI.....	49
5.6 CALLING ANOTHER VESSEL (CHANNEL 16 OR 9).....	9	9.3 DSC DISTRESS CALL.....	50
5.7 MAKING TELEPHONE CALLS.....	10	9.3.1 Transmitting a DSC Distress Call.....	50
5.8 BRIDGE CHANNELS 13 AND 67.....	10	9.3.2 Receiving a DSC Distress Call.....	53
5.9 AUTOMATED RADIO CHECK SERVICE.....	11	9.4 ALL SHIPS CALL.....	55
5.10 WHAT IS THE RANGE FOR AIS RECEIVERS?.....	12	9.4.1 Transmitting an All Ships Call.....	55
6 INSTALLATION.....	13	9.4.2 Receiving an All Ships Call.....	56
6.1 SAFETY / WARNING INFORMATION.....	13	9.5 INDIVIDUAL CALL.....	57
6.2 LOCATION.....	13	9.5.1 Setting up the Individual / Position Call Directory.....	57
6.3 MOUNTING THE RADIO.....	14	9.5.2 Setting up the Individual Call Reply.....	58
6.3.1 Supplied Mounting Bracket.....	14	9.5.3 Enabling the Individual Call Acknowledgment.....	59
6.3.2 Optional MMB-84 Flush Mount Bracket.....	15	9.5.4 Transmitting an Individual Call.....	59
6.4 ELECTRICAL CONNECTIONS.....	16	9.5.5 Receiving an Individual Call.....	61
6.5 ACCESSORY CABLES.....	17	9.5.6 Setting up the Individual Call Ringer.....	62
6.5.1 Internal GPS (DSC Output) to Chart Plotter.....	18	9.6 GROUP CALL.....	64
6.5.2 Connection to External GPS or Chart Plotter.....	19	9.6.1 Setting up a Group Call.....	64
6.6 CHECKING GPS CONNECTIONS.....	22	9.6.2 Transmitting a Group Call.....	66
6.7 CHANGING THE GPS TIME.....	23	9.6.3 Receiving a Group Call.....	68
6.8 CHANGING THE TIME LOCATION.....	24	9.6.4 Setting up the Group Call Ringer.....	69
6.9 CHANGING THE TIME FORMAT.....	25	9.7 POSITION REQUEST.....	70
6.10 CHANGING COG TO TRUE OR MAGNETIC.....	25	9.7.1 Setting up a Position Request Reply.....	70
6.11 OPTIONAL CMP30 (RAM3) INSTALLATION.....	26	9.7.2 Transmitting a Position Request to Another Vessel.....	71
6.11.1 Connecting an External Speaker to the RAM3 Mic Cable.....	28	9.7.3 Receiving a Position Request.....	72
6.11.2 External Speaker AF Selection.....	28	9.7.4 Setting up a Position Request Ringer.....	73
7 CONTROLS AND INDICATORS.....	29	9.8 POSITION REPORT.....	74
7.1 FRONT PANEL.....	29	9.8.1 Transmitting a DSC Position Report Call.....	74
7.2 REAR PANEL.....	31	9.8.2 Receiving a DSC Position Report Call.....	75
7.3 MICROPHONE.....	33	9.8.3 Navigating to a Position Report.....	76
8 BASIC OPERATION.....	34	9.8.4 Stopping Navigation to a Position Report.....	76
8.1 RECEPTION.....	34	9.8.5 Saving a Position Report as a Waypoint.....	76
8.2 TRANSMISSION.....	34	9.8.6 Navigating to a Saved Waypoint.....	77
8.3 TRANSMIT TIME - OUT TIMER (TOT).....	34	9.8.7 Setting up a Position Report Ringer.....	78
8.4 SIMPLE/DUPLEX CHANNEL USE.....	35	9.9 MANUAL INPUT OF A GPS LOCATION (LAT/LON).....	79
8.5 DISPLAY TYPE.....	35	9.10 AUTO POS POLLING.....	80
8.6 USA, INTERNATIONAL, AND CANADA MODE.....	36	9.10.1 Setting up the Polling Time Interval.....	80
8.7 NOAA WEATHER CHANNELS.....	36	9.10.2 Selecting Stations to be Automatically Polled (Tracked).....	80
8.7.1 NOAA Weather Alert.....	36	9.10.3 Enabling/Disabling Auto POS Polling.....	81
8.7.2 NOAA Weather Alert Testing.....	37	9.11 DSC TEST.....	82
8.8 DUAL WATCH (TO CHANNEL 16).....	37	9.11.1 Programming MMSI into Individual Directory.....	82
8.9 SCANNING.....	38	9.11.2 DSC Test call by using Individual/Position Directory.....	82
8.9.1 Selecting the Scan Type.....	38	9.11.3 DSC Test Call by Manually Entering an MMSI.....	83
8.9.2 Programming Scan Memory.....	39	9.12 POLLING CALL.....	84
8.9.3 Memory Scanning (M-SCAN).....	39	9.12.1 Transmitting a Polling Call to Another Vessel.....	84
8.9.4 Priority Scanning (P-SCAN).....	40	9.12.2 Receiving a Polling Call.....	85
8.10 PRESET CHANNELS (0 - 9): INSTANT ACCESS.....	40	9.13 DSC LOG OPERATION.....	86
8.10.1 Programming.....	40	9.13.1 Reviewing and Resending a Transmitted Logged Call.....	86
8.10.2 Operation.....	41	9.13.2 Reviewing a Logged DSC Distress Call.....	87
8.10.3 Deletion.....	41	9.13.3 Reviewing Other Logged Calls.....	88
8.11 PA/FOG OPERATION.....	42	9.13.4 Deleting a Call from the DSC Log Directory.....	88
8.11.1 Operating the PA HAIL mode.....	42	10 GENERAL SETUP.....	90
8.11.2 Operating the FOG HORN mode.....	43	10.1 DISPLAY.....	90

TABLE OF CONTENTS

10.2	LOCAL DISTANCE RECEIVER ATTENUATOR	90
10.3	DIMMER ADJUSTMENT	91
10.4	DISPLAY CONTRAST	91
10.8	UNIT OF MEASURE	92
10.9	NMEA DATA IN/OUT	93
10.10	KEY BEEP	93
10.11	FOG ALERT TONE FREQUENCY	94
10.12	STATION NAME	95
10.13	SOFT KEYS	96
11	CHANNEL FUNCTION SETUP	98
11.1	CHANNEL GROUP	98
11.2	SCAN MEMORY	98
11.3	SCAN TYPE	98
11.4	SCAN RESUME	98
11.5	PRIORITY CHANNEL	99
11.6	SECOND CHANNEL	99
11.7	WEATHER ALERT	100
11.8	CHANNEL NAME	100
11.9	SCRAMBLER SETUP	102
12	DSC SETUP	103
12.1	INDIVIDUAL DIRECTORY	103
12.2	INDIVIDUAL REPLY	103
12.3	INDIVIDUAL ACKNOWLEDGMENT	103
12.4	INDIVIDUAL RINGER	103
12.5	GROUP DIRECTORY	103
12.6	POSITION REPLY	104
12.7	AUTO POS INTERVAL	104
12.8	DSC BEEP	104
12.9	AUTO CHANNEL SWITCH TIME	105
12.10	NO ACTION TIMER ON MENU OPERATION	105
12.11	NO ACTION TIMER ON DSC OPERATION	106
12.12	NO ACTION TIMER ON DISTRESS OPERATION	106
13	AUTOMATIC IDENTIFICATION SYSTEM (AIS)	107
13.1	GENERAL	107
13.2	AIS OPERATION	108
13.2.1	AIS Range	109
13.2.2	Transmitting an Individual Call to an AIS Ship	109
13.2.3	Receiving an AIS-SART Signal	110
13.3	AIS/COMPASS SETUP	111
13.3.1	Direction	111
13.3.2	Activation Range	111
13.3.3	CPA Alarm	112
13.3.4	TCPA Alarm	113
13.3.5	Display Range	114
14	WAYPOINTS	115
14.1	MARKING A POSITION	115
14.2	ADDING A WAYPOINT	116
14.3	EDITING A WAYPOINT	117
14.4	DELETING A WAYPOINT	118
14.5	SAVING A DSC POSITION CALL AS A WAYPOINT	118
14.6	NAVIGATING TO A SAVED WAYPOINT	118
14.7	STOPPING NAVIGATION TO A WAYPOINT	119
14.8	SELECTING THE WAYPOINT RANGE	119
15	GPS SETUP	120
15.1	UNIT POWER	120
15.2	COORDINATE SYSTEM	120
15.3	PINNING	121
15.4	TIME OFFSET	121
15.5	TIME AREA	121
15.6	TIME DISPLAY	121
15.7	MAGNETIC	122
15.8	POSITION INPUT	122
15.9	POSITION DATA PRIORITY	122
15.10	SBAS (Satellite Based Augmentation System)	123
15.11	NMEA OUTPUT	124
16	CMP30 (RAM3) REMOTE MIC OPERATION	125
16.1	REMOTE MIC CONTROLS	125
16.2	ASSIGNING SOFT KEYS	127
17	MAINTENANCE	129
17.1	REPLACEMENT PARTS	129
17.2	FACTORY SERVICE	130
17.3	TROUBLESHOOTING CHART	131
18	CHANNEL ASSIGNMENTS	132
19	WARRANTY	138
20	RESET PROCEDURES	142
20.1	MEMORY CLEAR	142
20.2	MICROPROCESSOR RESETTING	142
21	SPECIFICATIONS	143
21.1	GENERAL	143
21.2	TRANSMITTER	143
21.3	RECEIVER (for Voice and DSC)	144
21.4	RECEIVER (for AIS)	144
21.5	GPS UNIT	144
21.5	NMEA INPUT/OUTPUT	145
21.6	DIMENSIONS	146
22	FCC RADIO LICENSE INFORMATION	147
22.1	STATION LICENSE	147
22.2	RADIO CALL SIGN	147
22.3	CANADIAN SHIP STATION LICENSING	147
22.4	FCC / INDUSTRY CANADA INFORMATION	147
23	FCC NOTICE	148

QUICK REFERENCE GUIDE

The **GX2200** is equipped with the E2O (Easy-To-Operate) system. Basic operation may be accomplished by following the procedure below:

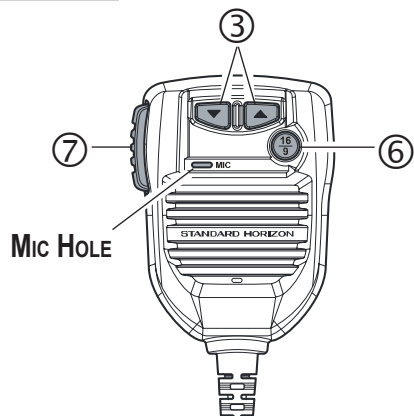
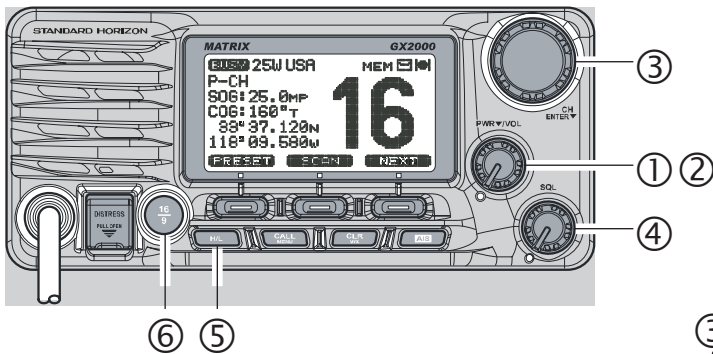

- ① Press and hold the **PWR/VOL** knob to turn on or off the radio.
- ② Rotate the **PWR/VOL** knob to adjust the speaker audio volume.
- ③ Rotate the **CH** knob (or press the microphone's  /  keys) to select the operating channel.
- ④ Move the **SQL** knob clockwise to squelch or counter clockwise to un-squelch the radio.
- ⑤ Press the  key to toggle the transmit power between High (25W) and Low (1W).
- ⑥ Press the  key on the radio or the microphone to select channel 16. Press and hold the  key on the radio or the microphone to select channel 9. Press again to revert to the last selected channel.
- ⑦ To transmit: place your mouth about 1/2 inch away from Mic hole and speak in a normal voice level while pressing the **PTT** switch.



1 GENERAL INFORMATION

The STANDARD HORIZON MATRIX Series **GX2200** Marine VHF/FM Marine transceiver is designed to be used in USA, International, and Canadian Marine bands. The **GX2200** can be operated from 11 to 16 VDC and has a switchable RF output power of 1 watt or 25 watts.

The **GX2200** integrates a dual channel AIS (Automatic Identification System) receiver to display AIS vessel information (MMSI, Call Sign, Ship Name, BRG, DST, SOG and COG) directly on the VHF radio, so you will know what is out there in any conditions. The **GX2200** is also capable of entering and saving up to 100 waypoints, which may be selected and navigated to by using a unique navigation compass display. The **GX2200** allows you to contact an AIS ship directly using DSC, show your vessels position in relation to AIS targets and alert you when an AIS ship may be approaching too close to your location via the Closest Point of Approach (CPA) Alarm. To receive AIS targets from ships with AIS class A or B transponders, simply connect the normal VHF antenna (only one antenna needed!).

The **GX2200** is capable of DSC (Digital Selective Calling) ITU Class D operation. Class D operation allows continuous receiving of Digital Selective Calling functions on channel 70 even if the radio is receiving a call. The **GX2200** operates on all currently-allocated marine channels which are switchable for use with USA, International, or Canadian regulations. Emergency channel 16 can be immediately selected from any channel by pressing the red  key. NOAA weather channel can also be accessed immediately by pressing and holding the  key.

Other features of the **GX2200** includes: a 12-channel internal GPS receiver, speaker microphone, 30W PA/Fog, optional **RAM3** second station remote-control microphone with AIS display, intercom between radio and optional **RAM3**, scanning, priority scanning, submersible speaker microphone, high and low voltage warning, and GPS repeatability.

2 PACKING LIST

When the package containing the transceiver is first opened, please check it for the following contents:

- **GX2200** Transceiver
- Power Cord
- Mounting Bracket and Hardware
- Owner’s Manual
- DSC Warning Sticker
- Flush Mount Template

3 OPTIONAL ACCESSORIES

MMB-84	Flush-Mount Bracket
CMP30B/W	Remote-Access Microphone (RAM3 Mic, Black/White)
CT-100	23 Feet Extension Cable for RAM3 Mic
CVS2500	Voice Scrambler
MLS-310	10W amplified External Speaker with on/off Volume control
MLS-300	External Loud Speaker
220SW	5” Round 30 Watt Hail/PA Horn
240SW	5” x 8” Rectangular 40 Watt Hail/PA Horn
HC2000	Dust Cover (White)
Q7000619A	External GPS Antenna with 30 Feet of Cable

4 ONLINE WARRANTY REGISTRATION (in USA or Canada only)

Please visit www.standardhorizon.com to register the **GX2200** Marine VHF. It should be noted that visiting the website from time to time may be beneficial to you, as new products are released they will appear on the STANDARD HORIZON website.

PRODUCT SUPPORT INQUIRIES

If you have any questions or comments regarding the use of the **GX2200**, you can visit the STANDARD HORIZON website to send an E-Mail or contact the Product Support team at (800) 767-2450 M-F 8:00-5:00 PST.

5 GETTING STARTED

5.1 PROHIBITED COMMUNICATIONS

The FCC prohibits the following communications:

- False distress or emergency messages;
- Messages to “any boat” except in emergencies and radio tests;
- Messages to or from a vessel on land;
- Transmission while on land;
- Obscene, indecent, or profane language (potential fine of \$10,000).

5.2 ABOUT VHF RADIO

The radio frequencies used in the VHF marine band lie between 156 and 158 MHz with some shore stations available between 161 and 163 MHz. The marine VHF band provides communications over distances that are essentially “line of sight” (VHF signals do not travel well through objects such as buildings, hills or trees). Actual transmission range depends much more on antenna type, gain and height than on the power output of the transmitter. On a fixed mount 25W radio transmission expected distances can be greater than 15 miles, for a portable 5W radio transmission the expected distance can be greater than 5 miles in “line of sight”.

5.3 SELECTING AN ANTENNA

Marine antennas are made to radiate signals equally in all horizontal directions, but not straight up. The objective of a marine antenna is to enhance the signal toward the horizon. The degree to which this is accomplished is called the antenna’s gain. It is measured in decibels (dB) and is one of the major factors in choosing an antenna. In terms of effective radiated power (ERP), antennas are rated on the basis of how much gain they have over a theoretical antenna with zero gain. A 3-foot, 3dB gain antenna represents twice as much gain over the imaginary antenna.

Typically a 3-foot 3dB gain stainless steel whip is used on a sailboat mast. The longer 8-foot 6dB fiberglass whip is primarily used on power boats that require the additional gain.

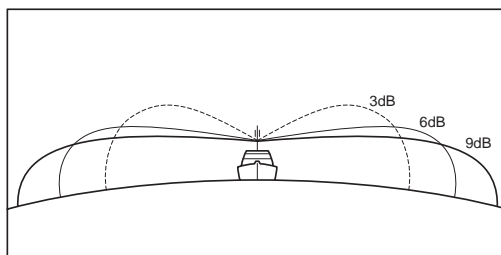

5.4 COAXIAL CABLE

VHF antennas are connected to the transceiver by means of a coaxial cable – a shielded transmission line. Coaxial cable is specified by its diameter and construction.

For runs less than 20 feet, RG-58/U, about 1/4 inch in diameter is a good choice. For runs over 20 feet but less than 50 feet, the larger RG-8X or RG-213/U should be used for cable runs over 50 feet RG-8X should be used. For installation of the connector onto the coaxial cable refer to the figure below.

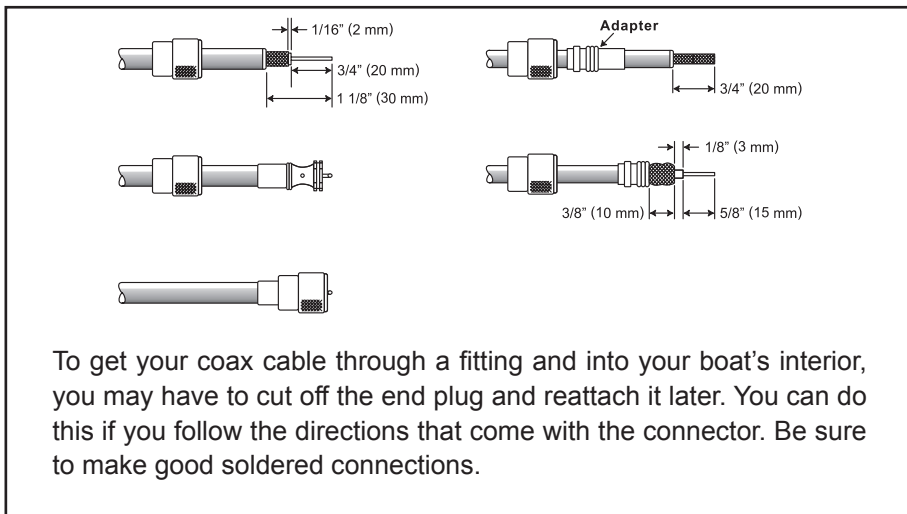

5.5 DISTRESS AND HAILING (CHANNEL 16)

Channel 16 is known as the Hail and Distress Channel. An emergency may be defined as a threat to life or property. In such instances, be sure the transceiver is on and set to CHANNEL 16. Then use the following procedure:

1. Press the microphone push-to-talk switch and say "**Mayday, Mayday, Mayday**. This is _____, _____, _____" (your vessel's name).
2. Then repeat once: "**Mayday, _____**" (your vessel's name).
3. Now report your position in latitude/longitude, or by giving a true or magnetic bearing (state which) to a well-known landmark such as a navigation aid or geographic feature such as an island or harbor entry.
4. Explain the nature of your distress (sinking, collision, aground, fire, heart attack, life-threatening injury, etc.).
5. State the kind of assistance your desire (pumps, medical aid, etc.).

6. Report the number of persons aboard and condition of any injured.
7. Estimate the present seaworthiness and condition of your vessel.
8. Give your vessel's description: length, design (power or sail), color and other distinguishing marks. The total transmission should not exceed 1 minute.
9. End the message by saying "**OVER**". Release the microphone button and listen.
10. If there is no answer, repeat the above procedure. If there is still no response, try another channel.

NOTE

The **GX2200** has the DSC Distress calling, that can transmit a distress call digitally to all ships with compatible DSC radios. Refer to section "**9 DIGITAL SELECTIVE CALLING (DSC)**".

5.6 CALLING ANOTHER VESSEL (CHANNEL 16 OR 9)

Channel 16 may be used for initial contact (hailing) with another vessel. However, its most important use is for emergency messages. This channel must be monitored at all times except when actually using another channel.

It is monitored by the U.S. and Canadian Coast Guards and by other vessels. **Use of channel 16 for hailing must be limited to initial contact only.** Calling should not exceed 30 seconds, but may be repeated 3 times at 2-minute intervals. In areas of heavy radio traffic, congestion on channel 16 resulting from its use as a hailing channel can be reduced significantly in U.S. waters by using **channel 9** as the initial contact (hailing) channel for non-emergency communications. Here, also, calling time should not exceed 30 seconds but may be repeated 3 times at 2-minute intervals.

Prior to making contact with another vessel, refer to the channel charts in this manual, and select an appropriate channel for communications after initial contact. For example, Channels 68 and 69 of the U.S. VHF Charts are some of the channels available to non-commercial (recreational) boaters. Monitor your desired channel in advance to make sure you will not be interrupting other traffic, and then go back to either channel 16 or 9 for your initial contact.

When the hailing channel (16 or 9) is clear, press the **PTT** button on the mic and state the name of the other vessel you wish to call and then "**this is**" followed by the name of your vessel and your Station License (Call Sign) then release the **PTT** button on the mic. When the other vessel returns your call, immediately request another channel by pressing the **PTT** button on

the mic and saying “**go to**,” the number of the other channel, say “**over**” and release the **PTT** button on the mic. Then switch to the new channel. When the new channel is not busy, call the other vessel.

After a transmission, say “**over**,” and release the microphone’s push-to-talk (**PTT**) switch. When all communication with the other vessel is completed, end the last transmission by stating your Call Sign and the word “**out**.” Note that it is not necessary to state your Call Sign with each transmission, only at the beginning and end of the contact.

Remember to return to Channel 16 when not using another channel. Some radios automatically monitor Channel 16 even when set to other channels or when scanning.

5.7 MAKING TELEPHONE CALLS

To make a radiotelephone call, use a channel designated for this purpose. The fastest way to learn which channels are used for radiotelephone traffic is to ask at a local marina. Channels available for such traffic are designated **Public Correspondence** channels on the channel charts in this manual. Some examples for USA use are Channels 24, 25, 26, 27, 28, 84, 85, 86, and 87. Call the marine operator and identify yourself by your vessel’s name. The marine operator will then ask you how you will pay for the call (telephone credit card, collect, etc.) and then link your radio transmission to the telephone lines.

The marine telephone company managing the VHF channel you are using may charge a link-up fee in addition to the cost of the call.

5.8 BRIDGE CHANNELS 13 AND 67

Channel 13 is used at docks, bridges and by vessels maneuvering in port. Messages on this channel must concern navigation only, such as meeting and passing in restricted waters.

Channel 67 is used for navigational traffic between vessels.

By regulation, power is normally limited to 1 Watt on these channels. Your radio is programmed to automatically reduce power to this limit on these channels. However, in certain situations it may be necessary to temporarily use a higher power. See page 30 ( key) for means to temporarily override the low-power limit on these two channels.

5.9 AUTOMATED RADIO CHECK SERVICE

In areas across the country, Sea Tow offers boaters a way to conduct radio checks. To use Sea Tow's free Automated Radio Check service, simply tune your VHF radio to the appropriate channel for your location and conduct a radio check as you typically would. Upon releasing your radio's microphone, the system will play an automated message and relay your transmission back to you, thereby letting you know how your signal will sound to other boaters.

The Automated Radio Check Service is currently available in the areas listed below.

West Coast	Sea Tow Newport/LA - Ch. 27 Sea Tow San Diego - Ch. 27
Northeast	Sea Tow Portland-Midcoast (Maine) - Ch. 27 Sea Tow Boston - Ch. 27 Sea Tow South Shore (Mass.) - Ch. 28 Sea Tow Rhode Island - Ch. 24 Sea Tow Eastern Long Island - Ch. 27 Sea Tow Huntington (N.Y.) - Ch. 27 Sea Tow Manasquan (N.J.) - Ch. 28
Mid-Atlantic	Sea Tow Northern Chesapeake (Md.) - Ch. 28 Sea Tow Central Chesapeake (Md.) - Ch. 27 Sea Tow Hampton Roads (Va.) - Ch. 28
North Carolina	Sea Tow Wrightsville Beach - Ch. 28 Sea Tow Ocean Isle Beach - Ch. 28
Florida	Sea Tow Sebastian - Ch. 28 Sea Tow Fort Lauderdale - Ch. 27 Sea Tow Charlotte Harbor - Ch. 24 Sea Tow Tampa Bay - Ch. 27 Sea Tow Horseshoe Beach - Ch. 27 Sea Tow Carrabelle/St. Marks - Ch. 27 Sea Tow Pensacola/Orange Beach (Ala.) - Ch. 27

5.10 WHAT IS THE RANGE FOR AIS RECEIVERS?

Since AIS uses similar frequencies as a marine VHF radio, it has similar radio reception capabilities - which are basically line of sight. This means that the higher the VHF antenna is mounted, the greater the reception area will be. Reception from Class A vessels that are 20 or even 30 miles away on open water is not uncommon as their antennas are mounted high off the water. Class B transponders use lower power for transmissions; therefore you can expect Class B vessels to be acquired when they are 5 to 10 miles away.

NOTE

The **GX2200** does not require a special marine VHF antenna to receive AIS transmissions. The **GX2200** does not transmit AIS signals, it is NOT recommended to use an antenna dedicated for AIS operation.

For additional information on AIS visit the USCG website:

<<http://www.navcen.uscg.gov/marcomms/ais.htm>>

6 INSTALLATION

6.1 SAFETY / WARNING INFORMATION

This radio is restricted to occupational use, work related operations only where the radio operator must have the knowledge to control the exposure conditions of its passengers and bystanders by maintaining the minimum separation distance of 3 feet (1 m). Failure to observe these restrictions will result in exceeding the FCC RF exposure limits.

Antenna Installation:

The antenna must be located at least 3 feet (1 m) away from passengers in order to comply with the FCC RF exposure requirements.

6.2 LOCATION

The radio can be mounted at any angle. Choose a mounting location that:

- is far enough from any compass to avoid any deviation in compass reading due to the speaker magnet
- provides accessibility to the front panel controls
- allows connection to a power source and an antenna
- has nearby space for installation of a microphone hanger
- is at least 3 feet (1 m) away from the radio's antenna
- the signal from the GPS satellite can receive sufficiently.

Note: To insure the radio does not affect the compass or radios performance is not affected by the antenna location, temporarily connect the radio in the desired location and:

- a. Examine the compass to see if the radio causes any deviation
- b. Connect the antenna and key the radio. Check to ensure the radio is operating correctly by requesting a radio check.

6.3 MOUNTING THE RADIO

6.3.1 Supplied Mounting Bracket

The supplied mounting bracket allows overhead or desktop mounting.

Use a 13/64" (5.2 mm) bit to drill the holes to a surface which is more 0.4" (10 mm) thick and can support more than 3.3 lbs (1.5 kg) and secure the bracket with the supplied screws, spring washers, flat washers, and nuts.

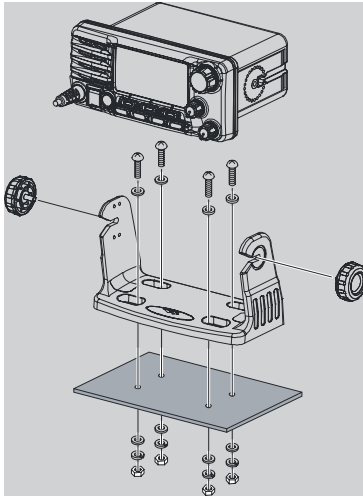

DESKTOP MOUNTING

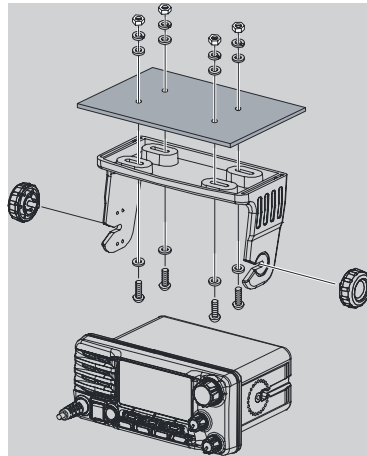

OVERHEAD MOUNTING

6.3.2 Optional MMB-84 Flush Mount Bracket

1. Use the supplied template to mark the location where the rectangular hole is to be cut. Confirm the space behind the dash or panel is deep enough to accommodate the transceiver (at least 6.7" (17 cm) deep). There should be at least 1/2" (1.3 cm) between the transceiver's heatsink and any wiring, cables or structures.
2. Cut out the rectangular hole and insert the transceiver.
3. Fasten the brackets to the sides of the transceiver with the lock washer screw combination; so that the mounting screw base faces the mounting surface (see illustration below).
4. Turn the adjusting screw to adjust the tension so that the transceiver is tight against the mounting surface.

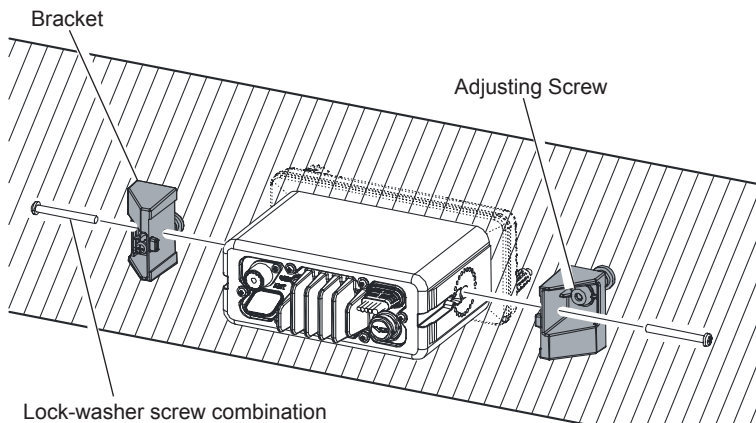

NOTE

A GPS receiver and antenna of the **GX2200** is located in the front panel. In many cases the radio may be flush mounted, however before cutting holes to flush mount the radio it is recommended to temporarily connect the radio to power and turn on in the location where it will be flush mounted to confirm it is able to receive a GPS location on it's display. If the radio is not able to receive a location, a GPS Chart plotter with NMEA 0183 output or the optional Standard Horizon external GPS antenna may be needed to receive GPS satellite signals.

To use the optional Standard Horizon external GPS antenna (Q7000619A), the **GX2200** internal GPS Unit Power must be turned OFF (refer to section "**15.1 UNIT POWER**") and the GPS Selection changed to External GPS (refer to section "**15.9 POSITION DATA PRIORITY**").

6.4 ELECTRICAL CONNECTIONS

CAUTION

Reverse polarity battery connections will damage the radio!

Connect the power cord and antenna to the radio. Antenna and Power Supply connections are as follows:

1. Mount the antenna at least 3 feet (1 m) away from the radio. At the rear of the radio, connect the antenna cable. The antenna cable must have a PL259 connector attached. RG-8/U coaxial cable must be used if the antenna is 25 feet (7.6 m) or more from the radio. RG58 cable can be used for distances less than 25 feet (7.6 m).
2. Connect the red power wire to a 13.8 VDC \pm 20% power source. Connect the black power wire to a negative ground.
3. If an optional remote extension speaker is to be used, refer to section 6.5 for connections.
4. It is advisable to have a Certified Marine Technician check the power output and the standing wave ratio of the antenna after installation.

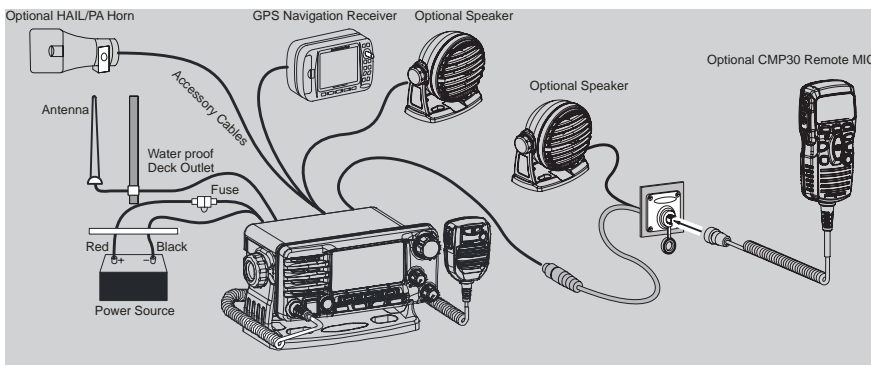

Fuse Replacement

To take out the fuse from the fuse holder, hold both ends of the fuse holder and pull the fuse holder apart without bending the fuse holder. When you replace the fuse, please confirm that the fuse is tightly fixed on the metal contact located inside the fuse holder. If the metal contact holding the fuse is loose, the fuse holder may heat up.

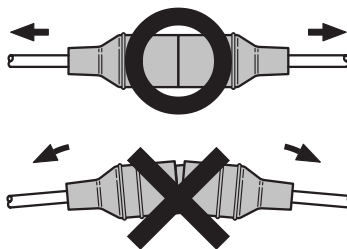

6.5 ACCESSORY CABLES

The image and table below show the wires of the MATRIX Series and the connections to optional devices such as a PA speaker (horn), external speaker, GPS chart plotter and an AIS receiver or transponder.

CAUTION

Care must be taken not to touch any of the NMEA wires to positive 12 VDC or the radio may be damaged.

When connecting the external speaker or GPS navigation receiver, strip off about 1 inch (2.5 cm) of the specified wire's insulation, then splice the ends together.

The **GX2200** uses NMEA 0183 protocol to share coordinates, DSC and AIS information to and from a GPS chart plotter. The **GX2200** transfers AIS information to a GPS chart plotter or PC at 38400 baud (sometimes called HS). GPS and DSC information is transferred between a GPS chart plotter with multiple ports (minimum 2) at 4800 baud (default setting).

To connect to a GPS chart plotter which has one NMEA port, the **GX2200** may be setup to receive GPS coordinates, send DSC and AIS signals at 38400 baud. Refer to section “**10.9 NMEA DATA IN/OUT**” for details.

6.5.1 Internal GPS (DSC Output) to Chart Plotter

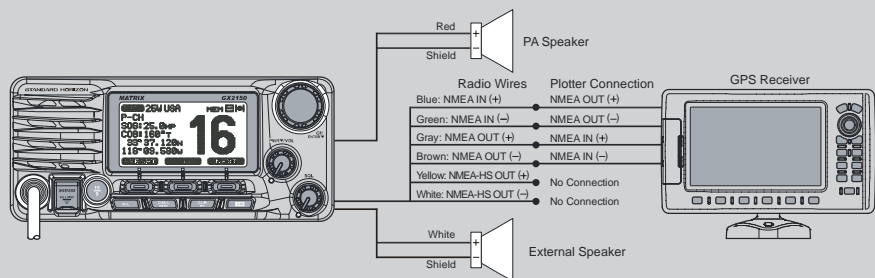

Wire Color/Description	Connection Examples
WHITE - External Speaker (+)	Positive wire of external 4 Ohm audio speaker
SHIELD - External Speaker (-)	Negative wire of external 4 Ohm audio speaker
RED - PA Speaker (+)	Positive wire of external 4 Ohm PA speaker (horn)
SHIELD - PA Speaker (-)	Negative wire of external 4 Ohm PA speaker (horn)
BLUE - NMEA GPS Input (+)	NMEA (+) output of GPS*1
GREEN - NMEA GPS Input (-)	NMEA (-) output or common ground of GPS*1
GRAY - NMEA DSC Output (+)	NMEA (+) input of GPS*1
BROWN - NMEA DSC Output (-)	NMEA (-) input of GPS*1
YELLOW - AIS Data Output (+)	No connection*2
WHITE - AIS Data Output (-)	No connection*2

*1: The GPS chart plotter ComPort must be setup to 38400 baud (HS) to send GPS coordinates to the **GX2200** (Blue and Green wires) and to receive DSC and AIS sentences from the **GX2200** (Gray and Brown wires).

*2: The **GX2200** always outputs NMEA 0183 VDM sentence at 38400.

Note: Some GPS chart plotters have a single wire for NMEA signal ground. In such a case connect the NMEA input (-) to the GPS chart plotter's single NMEA signal ground wire, and leave the NMEA output (-) open. In case the assignment of power supply and ground of a GPS chart plotter to be used is different from that of the radio, connect the signal ground wire of the GPS chart plotter to the ground terminal (GND) on the rear panel of the radio.

6.5.2 Connection to External GPS or Chart Plotter

4800 Baud Connections

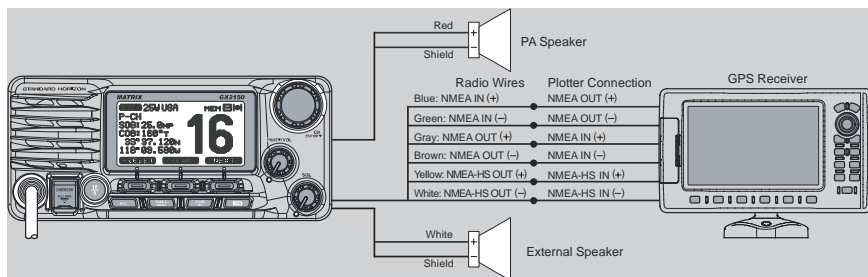

Wire Color/Description	Connection Examples
WHITE - External Speaker (+)	Positive wire of external 4 Ohm audio speaker
SHIELD - External Speaker (-)	Negative wire of external 4 Ohm audio speaker
RED - PA Speaker (+)	Positive wire of external 4 Ohm PA speaker (horn)
SHIELD - PA Speaker (-)	Negative wire of external 4 Ohm PA speaker (horn)
BLUE - NMEA GPS Input (+)	NMEA (+) output of GPS* ¹
GREEN - NMEA GPS Input (-)	NMEA (-) output or common ground of GPS
GRAY - NMEA DSC Output (+)	NMEA (+) input of GPS* ¹
BROWN - NMEA DSC Output (-)	NMEA (-) input of GPS
YELLOW - AIS Data Output (+)	NMEA-HS (+) input of AIS receiver* ²
WHITE - AIS Data Output (-)	NMEA-HS (-) input of AIS receiver* ²

*1: 4800 baud

*2: 38400 baud

Note: Some GPS chart plotters have a single wire for NMEA signal ground. In such a case connect the NMEA input (-) to the GPS chart plotter's single NMEA signal ground wire, and leave the NMEA output (-) open. In case the assignment of power supply and ground of a GPS chart plotter to be used is different from that of the radio, connect the signal ground wire of the GPS chart plotter to the ground terminal (GND) on the rear panel of the radio.

38400 Baud Connections

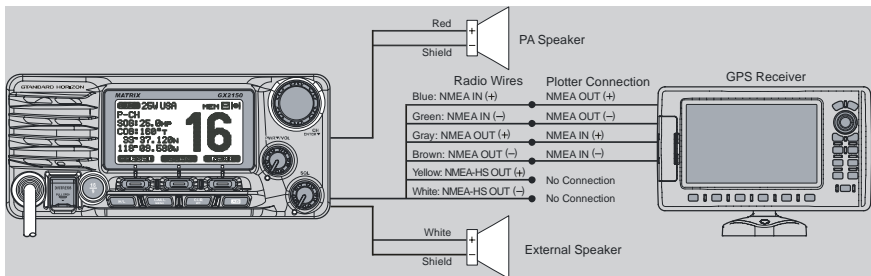

Wire Color/Description	Connection Examples
WHITE - External Speaker (+)	Positive wire of external 4 Ohm audio speaker
SHIELD - External Speaker (-)	Negative wire of external 4 Ohm audio speaker
RED - PA Speaker (+)	Positive wire of external 4 Ohm PA speaker (horn)
SHIELD - PA Speaker (-)	Negative wire of external 4 Ohm PA speaker (horn)
BLUE - NMEA GPS Input (+)	NMEA (+) output of GPS*1
GREEN - NMEA GPS Input (-)	NMEA (-) output or common ground of GPS*1
GRAY - NMEA DSC Output (+)	NMEA (+) input of GPS*1
BROWN - NMEA DSC Output (-)	NMEA (-) input of GPS*1
YELLOW - AIS Data Output (+)	No connection*2
WHITE - AIS Data Output (-)	No connection*2

*1: The GPS chart plotter ComPort must be setup to 38400 baud (HS) to send GPS coordinates to the **GX2200** (Blue and Green wires) and to receive DSC and AIS sentences from the **GX2200** (Gray and Brown wires).

*2: The **GX2200** always outputs NMEA 0183 VDM sentence at 38400.

Note: Some GPS chart plotters have a single wire for NMEA signal ground. In such a case connect the NMEA input (-) to the GPS chart plotter's single NMEA signal ground wire, and leave the NMEA output (-) open. In case the assignment of power supply and ground of a GPS chart plotter to be used is different from that of the radio, connect the signal ground wire of the GPS chart plotter to the ground terminal (GND) on the rear panel of the radio.

In some areas powerful AM broadcast stations may be heard when in listen-back mode. In this case change the speaker wire to 2-conductor shielded audio cable. See the illustration below for connections.

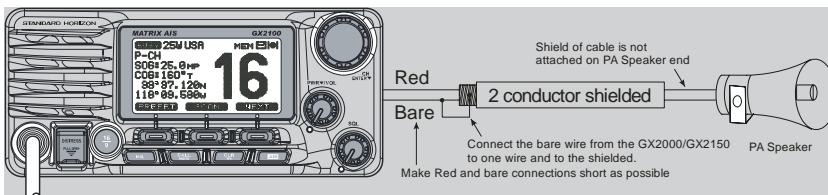

External GPS Connections (4800 baud or 38400 baud)

The **GX2200** can select the NMEA baud rate between “4800 bps” and “38400 bps”. Refer to section “**10.9 NMEA DATA IN/OUT**” for selection.

NMEA Input (GPS Information)

- **GX2200** can read NMEA-0183 version 2.0 or higher.
- The NMEA 0183 input sentences are GLL, GGA, RMC, GNS, GSA, and GSV (RMC sentence is recommended).
- If 4800 baud (default) is selected:
 - a. If there is a selection for “PARITY” select “NONE”.
 - b. The Blue and Green wires of input are at 4800 baud.
- If 38400 baud is selected:
 - a. The Blue and Green wires of input are at 38400 baud.
 - b. The Yellow and White wires are used for input of both NMEA and AIS VDM sentences at 38400 baud.

NMEA Output (DSC and GPS information)

- The NMEA 0183 output sentences are DSC and DSE.
- If 4800 baud (default) is selected:
 - a. The Gray and Brown wires output DSC and DSE sentences.
 - b. The Yellow and White wires of output AIS VDM sentence at 38400 baud.
- If 38400 baud is selected:
 - a. The Gray and Brown wires of output are at 38400 baud and includes both DSC (DSC, DSE) and AIS (VDM) sentences.
 - b. The Yellow and White wires always output AIS sentences at 38400 baud.
- GSA, GSV, GLL, GGA, and RMC sentences can be output in the **GX2200** by setting through the GPS setup menu (refer to section “**15.11 NMEA OUTPUT**”).

NOTE

When the GPS reception is limited, such as the flush mounting of the **GX2200**, the NMEA input (+) (blue) and NMEA input (-) (green) wires may be connected to the NMEA output connections of an external GPS antenna or a GPS chart plotter. To change the **GX2200** from using the internal GPS antenna to the external GPS antenna, refer to section “**15.9 POSITION DATA PRIORITY**” (for selection), and “**15.1 UNIT POWER**” (for turning off).

For further information on interfacing/setting up your GPS, please contact the manufacturer of the GPS receiver externally connected.

If you have further inquiries, please feel free to contact Product Support at:

Phone: (800) 767-2450

Email: marinetech@yaesu.com

6.6 CHECKING GPS CONNECTIONS

When the **GX2200** receives the GPS signal through the internal GPS, or from an external GPS antenna or chart plotter, a small satellite icon or “**IO**” will appear on the top right corner of the display and your current location (latitude/longitude) is shown on the display.

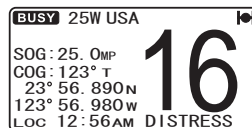
**NOTE**

If there is a problem with the NMEA connection between the radio and the GPS, the GPS icon will blink continuously until the connection is corrected.

The **GX2200** has a GPS status display which shows the satellites currently being received, along with a graphical (bar-graph) representation of the relative signal strengths from the satellites.

NOTE

For the **GX2200** to properly show the GPS status page when an external GPS antenna or a chart plotter is connected it must be setup to output GSA and GSV NMEA 0183 sentences.

1. Press and hold the **CALL MENU** key until “Setup Menu” appears, then select “GENERAL SETUP” with the **CH** knob.
2. Press the **SELECT** soft key, then select “DISPLAY” with the **CH** knob.
3. Press the **SELECT** soft key, then select “GPS STATUS” with the **CH** knob.
4. Press the **ENT** soft key to display the GPS status currently being received.
5. Press the **QUIT** soft key two times to return to radio operation.

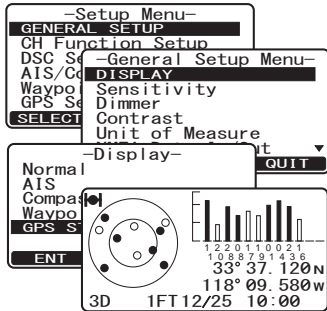

NOTE

When the **GX2200** is first turned on, it may take several minutes to compute a fix of your position. This is normal, as the **GX2200** is downloading “almanac” information from the GPS satellites.

6.7 CHANGING THE GPS TIME

From the factory the **GX2200** shows GPS satellite time or UTC (Universal Time Coordinated) time. A time offset is needed to show the local time in your area. The time offset must be changed in order for the radio to display the current time in your area. See the Offset Time Table below.

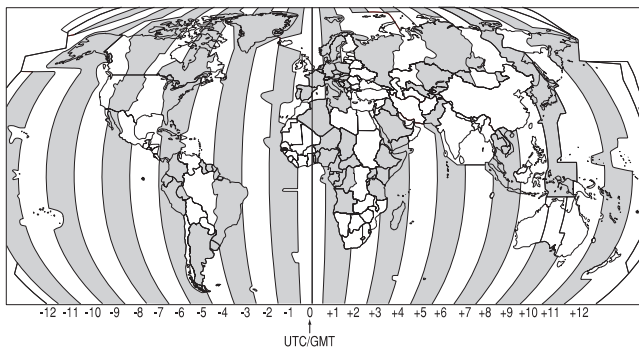

OFFSET TIME TABLE

1. Press and hold the **CALL MENU** key until “Setup Menu” appears, then select “GPS SETUP” with the **CH** knob.
2. Press the **SELECT** soft key, then select “TIME OFFSET” with the **CH** knob.
3. Press the **SELECT** soft key, then rotate the **CH** knob to select time offset of your location. See illustration above to find your offset time. If “00:00” is assigned, the time is the same as UTC or GPS satellite time.
4. Press the **ENT** soft key to store the time offset.
5. Press the **QUIT** soft key two times to return to radio operation.

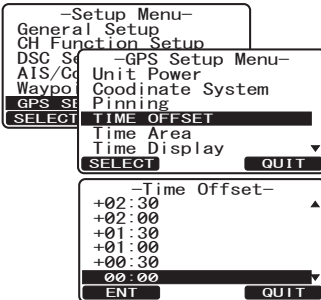

6.8 CHANGING THE TIME LOCATION



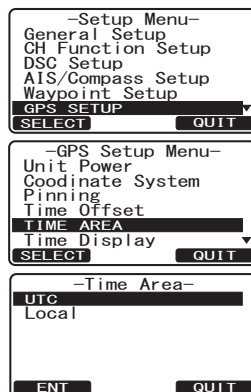

This menu selection allows the radio to show UTC time or local time with the offset.

1. Press and hold the **CALL MENU** key until “Setup Menu” appears, then select “GPS SETUP” with the **CH** knob.
2. Press the **SELECT** soft key, then rotate the **CH** knob to “TIME AREA”.
3. Press the **SELECT** soft key.
4. Rotate the **CH** knob to select “UTC” or “LOCAL”.
5. Press the **ENT** soft key to store the selected setting.
6. Press the **QUIT** soft key two times to return to radio operation.



6.9 CHANGING THE TIME FORMAT



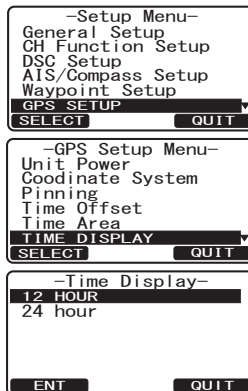

This menu selection allows the radio to setup to show time in 12-hour or 24-hour format.

1. Press and hold the  key until "Setup Menu" appears, then select "GPS SETUP" with the **CH** knob.
2. Press the  soft key, then rotate the **CH** knob to select "TIME DISPLAY".
3. Press the  soft key.
4. Rotate the **CH** knob to select "12 HOUR" or "24 HOUR".
5. Press the  soft key to store the selected setting.
6. Press the  soft key two times to return to radio operation.



6.10 CHANGING COG TO TRUE OR MAGNETIC

Allows the GPS COG (Course Over Ground) and the BRG from an AIS target to be selected to show in True or Magnetic. Factory default is "True" however by following the steps below the COG can be changed to "Magnetic".

1. Press and hold the  key until "Setup Menu" appears, then select "GPS SETUP" with the **CH** knob.
2. Press the  soft key, then rotate the **CH** knob to select "MAGNETIC".
3. Press the  soft key.
4. Rotate the **CH** knob to select "MAGNETIC" or "TRUE".
5. Press the  soft key to store the selected setting.
6. Press the  soft key two times to return to radio operation.

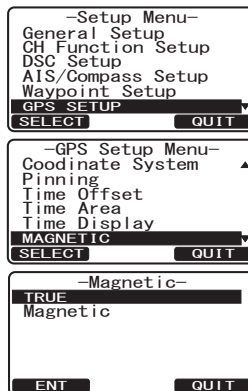

NOTE

Setting to "Magnetic" is effective only when the RMC sentences with magnetic data are input from external devices such as a GPS receiver. It is ineffective when using the internal GPS of the **GX2200**.

6.11 OPTIONAL CMP30 (RAM3) INSTALLATION

The **GX2200** is capable of using a **CMP30 (RAM3)** Remote Station Microphone to remotely control the Radio, AIS, DSC and PA/Fog functions. In addition the **GX2200** can operate as a full function intercom system between the **CMP30 (RAM3)** and the **GX2200**.

1. Connect the extension cable to the remote microphone eight pin connector on the rear panel, then tighten the cable nut (see illustration at the right).

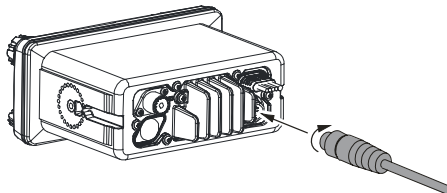

2. Install the ferrite core (supplied with the **CMP30 (RAM3)** Remote Station Microphone) to the extension cable, then snap its two halves together, per the illustration on the next page.
3. Attach the ferrite core as close as possible to the MIC plug, as shown below.
4. Finally, wind some plastic tape around each ferrite core, to prevent vibration from causing the two halves to split apart.

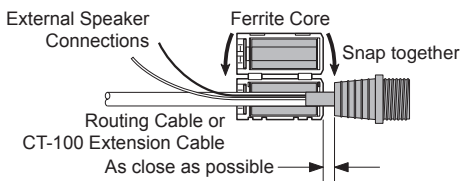

5. Referring to illustration below, make a 1.2" (30 mm) hole in the wall, then insert the extension cable into this hole. Connect the gasket and mount base to the extension cable connector using the nut.
6. Drill the four screw holes (approx. 2 mm) on the wall, then install the mounting base to the wall using four screws.
7. Put the rubber cap on to the nut. The installation is now complete.

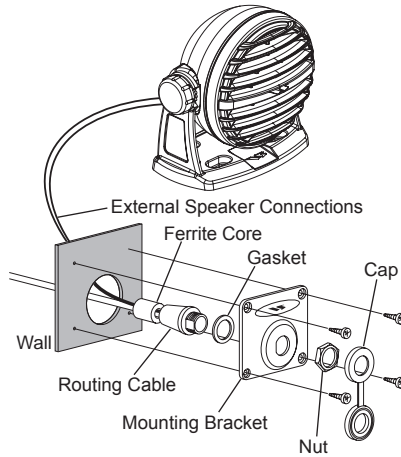

NOTE

Caution!: Before cutting the cable, it must be disconnected from the rear panel of the transceiver.

The routing cable can be cut and spliced, however care needs to be taken when reconnecting the wires to ensure water integrity.

After cutting you will notice there are the following wires:

Yellow, White, Brown, Gray, Blue, Green, Red/White[※], Shield[※]











※ The red/white and shield wires are wrapped in foil. Remove the foil, and separate the red/white and shield wires.

WARNING

It is not recommended to plug or unplug the **CMP30 (RAM3)** Remote Station Microphone into the routing cable while the radio is on.

6.11.1 Connecting an External Speaker to the RAM3 Mic Cable





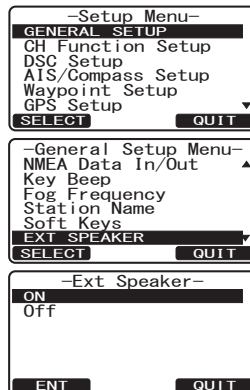





In noisy locations and optional external speaker may be connected to the white speaker wires on the **RAM3** routing cable. The **RAM3** can drive the internal speaker or the external speaker one at a time. When connecting an external speaker, follow the procedure below to turn off the **RAM3** audio and enable the external speaker wires on the **RAM3** routing cable.

1. On the **RAM3** mic, press and hold the  key until "Setup Menu" appears, then select "GENERAL SETUP" with the  /  key.
2. Press the  key.
3. Press the  key to until "EXT SPEAKER" is shown and press the  soft key.
4. Press the  or  key to select "OFF" (External speaker off) or "ON" (External speaker on).
5. Press the  soft key to save the selection.
6. Press the  key to exit this mode.



6.11.2 External Speaker AF Selection

The "AF Select" menu allows you to set the audio output level of the **RAM3** external speaker wires (on routing cable) to a fixed level regardless of the volume level setting of the **RAM3** which is useful when using the optional **MLS-310** amplified speaker with on/off volume control.

1. On the **RAM3** mic, press and hold the  key until "Setup Menu" appears, then select "GENERAL SETUP" with the  /  key.
2. Press the  key.
3. Press the  key to until "AF SELECT" is shown and press the  soft key.
4. Press the  or  key to select "PRE-OUT" (external speaker level is "Fixed") or "PA-OUT" (external speaker level is "Adjustable").
Use "Fixed" when **MLS-310** is connected.
Use "Adjustable" when **MLS-300** or other speaker without volume control is connected.
5. Press the  soft key to save the selection.
6. Press the  key to exit this mode.

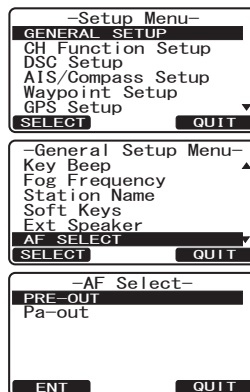

7 CONTROLS AND INDICATORS

NOTE

This section defines each control of the transceiver. See illustration at the next page for location of controls. For detailed operating instructions refer to chapter 8 of this manual.

7.1 FRONT PANEL

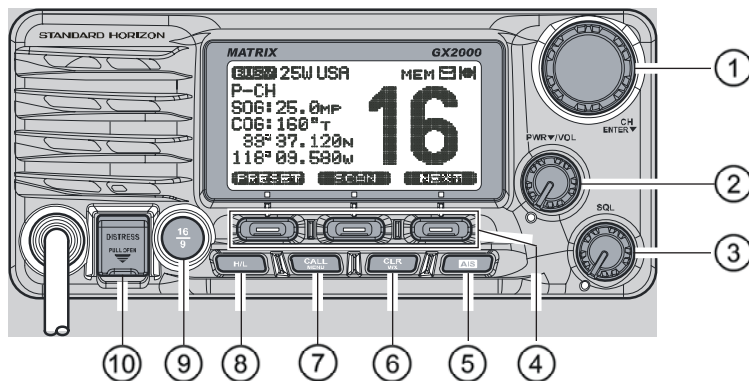

① CH Knob (Channel Selection)

Rotary knob is used to select channels and to choose menu items (such as the DSC menu, General Setup and DSC Setup menu). The / keys on the microphone can also be used to select channels and menu items.

SECONDARY USE

- Press this knob to enter a selection in the setup menu or DSC menu.
- While holding the **SCAN** soft key and turning this knob, you can confirm memory channels that have been programmed for scanning.
- When in the PA or Fog mode, turning this knob changes the output volume of the connected horn speaker.

② PWR/VOL Knob (Power Switch / Volume Control)

Turns the transceiver on and off as well as adjusts the speaker volume.

To turn the transceiver on, press and hold this knob until the radio turns on.

When the power is turned on, the transceiver is set to the last selected channel. Clockwise rotation of this knob increases the internal and speaker microphone volume.

To turn the transceiver off, press and hold this knob until the radio turns off.

SECONDARY USE

When in PA or Fog mode, controls the listen-back volume.

③ **SQL Knob (Squelch Control)**

Adjusting this control clockwise, sets the point at which random noise on the channel does not activate the audio circuits but a received signal does. This point is called the squelch threshold. Further adjustment of the squelch control will degrade reception of wanted transmissions.

④ **Soft Keys**

The 3 programmable soft keys can be customized by the Setup Menu mode section “**10.13 SOFT KEYS**”. When one of the soft keys is pressed briefly, the functions will appear above each key on the display.

The factory defaults are Key 1: **PRESET**, Key 2: **SCAN**, Key 3: **DW**, and Key 4: **PA/FOG**.

⑤ **AIS** Key

Press the **AIS** key to display the AIS (Automatic Identification System) targets information on the display. Refer to section “**13.2 AIS OPERATION**” for details.

⑥ **CLR WX** Key

Press the **CLR WX** key briefly to cancel a selection the “Setup Menu” and “DSC Menu”.

Press and hold the **CLR WX** key to recall the previously selected NOAA weather channel from any channel. Press and hold the **CLR WX** key again reverts to the previous selected working channel.

⑦ **CALL MENU** Key

Press the **CALL MENU** key to access the “DSC MENU”.

SECONDARY USE

Press and hold the **CALL MENU** key to access the “SETUP MENU”.

⑧ **H/L** Key

Press the **H/L** key to toggle between 25 W (High) and 1 W (Low) power. When the TX output power is set to “Low” while the transceiver is on channel 13 or 67, the output power will temporarily switch from “Low” to “High” power until the **PTT** switch of the microphone is released. The **H/L** key does not function on transmit inhibited and low power only channels.

⑨ $\frac{16}{9}$ Key

Press the $\frac{16}{9}$ key briefly to recall Channel 16 from any channel location. Press and hold the $\frac{16}{9}$ key to recall Channel 9. Pressing the $\frac{16}{9}$ key again reverts to the previous selected working channel.

⑩ **DISTRESS** Key

Used to send a DSC distress call. To send the distress call refer to section “9.3.1 Transmitting a DSC Distress Call”.

7.2 REAR PANEL

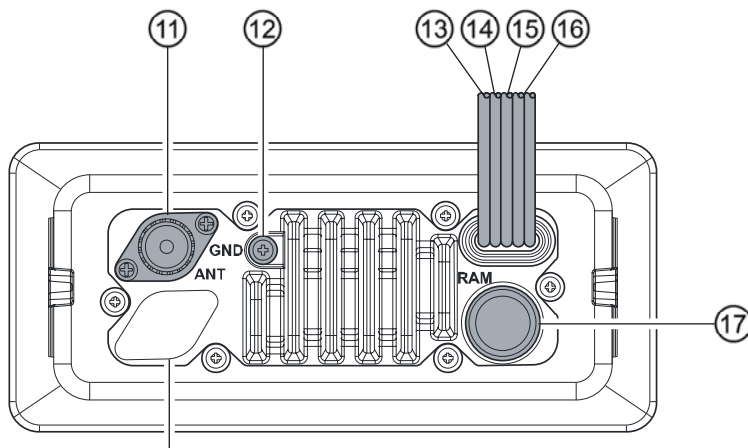

**Never remove this rubber cap.
When this rubber cap is removed,
the water resistance performance is
lost.**

⑪ **ANT** Jack (Antenna Jack)

Connects an antenna to the transceiver. Use a marine VHF antenna with an impedance of 50 ohms.

Note: On the **GX2200** the antenna connection is used to receive marine and AIS receiver.

⑫ **GND** Terminal (Ground Terminal)

Connects the **GX2200** to a good ground, for safe and optimum performance.

Use the screw supplied with the **GX2200** only.

⑬ External Speaker Connection Cable (White & Shield)

Connects the **GX2200** to an external speaker. See section “3 OPTIONAL ACCESSORIES” for a list of optional STANDARD HORIZON Speakers.

- ⑭ **PA Speaker Connection Cable (Red & Shield)**
Connects the **GX2200** to an optional PA speaker. Refer to section “**3 OPTIONAL ACCESSORIES**” for a list of optional STANDARD HORIZON Speakers.
- ⑮ **DC Input Cable**
Connects the radio to a DC power supply capable of delivering 11 to 16V DC.
- ⑯ **Accessory Connection Cable (Blue, Green, Gray, Brown, Yellow & White)**
Connects the **GX2200** to a GPS chart plotter. Refer to section “**6.5 ACCESSORY CABLES**”.
- ⑰ **RAM3 Connector (Remote Station Microphone Connector)**
Connects the **GX2200** to the **CMP30 (RAM3)** Remote Station Microphone. Refer to section “**16 CMP30 (RAM3) REMOTE MIC OPERATION**” for details.

7.3 MICROPHONE

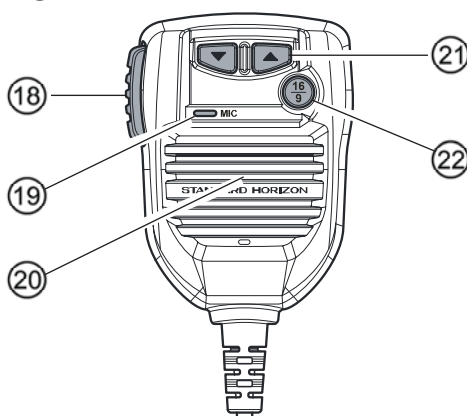

18 PTT Switch (Push-To-Talk Switch)

When in radio mode and the **PTT** switch is pressed, the transmitter is enabled for voice communications to another vessel.

When PA mode is selected, pressing the **PTT** switch allows your voice to be amplified and supplied to a connected PA horn.

When an optional **RAM3** mic is connected and intercom mode is selected, pressing the **PTT** switch enables voice communications from the **GX2200** to the **RAM3** second station microphone.

19 Microphone



The microphone has ClearVoice Noise Reduction Technology which reduces the amount of background (wind, engine) noise transmitted.

Note: Position your mouth about 1/2" (1.5 cm) away from the microphone hole and speak in a normal voice.



20 Microphone Speaker

Audio heard through internal radio speaker is heard through speaker inside the microphone.

21 / Keys (DOWN/UP Keys)

The  and  keys on the microphone are used to select channels and to choose menu items (such as the DSC menu, General Setup and DSC Setup menus).

22 Key

Pressing the  key immediately recalls Channel 16 from any location. Press and hold the  key to recall Channel 9. Pressing the  key again will revert the radio to the previous selected channel.

8 BASIC OPERATION

8.1 RECEPTION

1. After the transceiver has been installed, ensure that the power supply and antenna are properly connected.
2. Press and hold the **PWR/VOL** knob until the radio turns on.
3. Rotate the **SQL** knob fully counterclockwise. This state is known as “squelch off”.
4. Turn up the **PWR/VOL** knob until noise or audio from the speaker is at a comfortable level.
5. Rotate the **SQL** knob clockwise until the random noise disappears. This state is known as the “squelch threshold.”
6. Rotate the **CH** knob to select the desired channel. Refer to the channel chart on page 128 for available channels.
7. When a message is received, adjust the volume to the desired listening level. The “**BUSY**” indicator on the display indicates that communications are being received.

8.2 TRANSMISSION

1. Perform steps 1 through 6 of RECEPTION.
2. Before transmitting, monitor the channel to ensure it is clear.
THIS IS AN FCC REQUIREMENT!
3. Press the **PTT** (push-to-talk) switch. The “**T X**” indicator on the LCD is displayed.
4. Speak slowly and clearly into the microphone.
5. When the transmission is finished, release the **PTT** switch.

NOTE

This is a noise-canceling microphone. Position the oval slot labeled “**MIC**” within 1/2” (1.5 cm) from the mouth for optimum performance.

8.3 TRANSMIT TIME - OUT TIMER (TOT)

When the **PTT** switch on the microphone is held down, transmit time is limited to 5 minutes. This limits unintentional transmissions due to a stuck microphone. About 10 seconds before automatic transmitter shutdown, a warning beep will be heard from the speaker(s). The transceiver will automatically go to receive mode, even if the **PTT** switch is continually held down. Before transmitting again, the **PTT** switch must first be released and then pressed again.

8.4 SIMPLEX/DUPLEX CHANNEL USE

Refer to the VHF MARINE CHANNEL CHART (page 135) for instructions on use of simplex and duplex channels.

NOTE

All channels are factory-programmed in accordance with FCC (USA), Industry Canada (Canada), and International regulations. Mode of operation cannot be altered from simplex to duplex or vice-versa.

8.5 DISPLAY TYPE

The **GX2200** display can be setup to show displays other than the default “NORMAL” VHF display by using the procedure below:

1. Press and hold the **CALL MENU** key until “Setup Menu” appears, then select “GENERAL SETUP” with the **CH** knob.
2. Press the **SELECT** soft key, then rotate the **CH** knob to select “DISPLAY”.
3. Press the **SELECT** soft key.
4. Rotate the **CH** knob to select desired screen “NORMAL”, “AIS”, “COMPASS”, “WAYPOINT”, or “GPS STATUS”.
5. Press the **ENT** soft key to store the selected setting.
6. Press the **QUIT** soft key two times to return to radio operation.

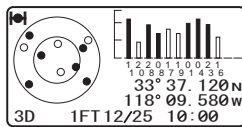
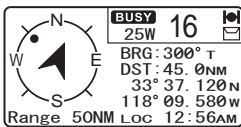
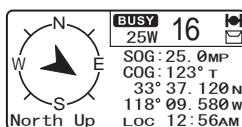
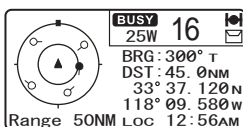
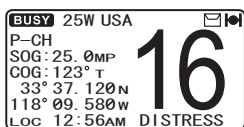
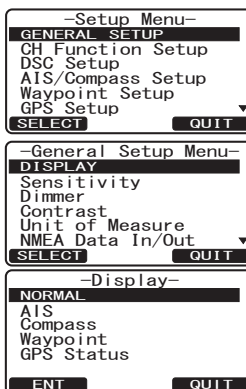





※1: By default the COG in “NORMAL” and “COMPASS” displays and BRG in “AIS”, “COMPASS”, and “WAYPOINT” displays are set to “True”, however this may be change to magnetic by following the steps in section “6.10 CHANGING COG TO TRUE OR MAGNETIC”.

NOTE

When the “GPS STATUS” mode is selected in step 4 above, the display will show the GPS status until a key is pressed.



8.6 USA, INTERNATIONAL, AND CANADA MODE

To change the channel group from USA to International or Canada:

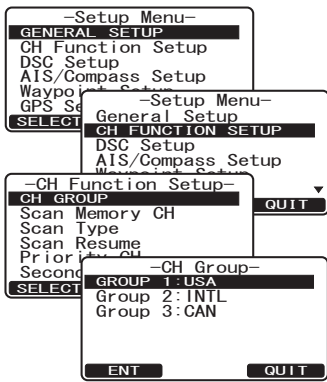
1. Press and hold the  key until “Setup Menu” appears.
2. Rotate the **CH** knob to select “CH FUNCTION SETUP”.
3. Press the  soft key, then rotate the **CH** knob to select “CH GROUP”.
4. Press the  soft key.
5. Rotate the **CH** knob to select desired channel group “USA”, “INTL”, or “CAN”.
6. Press the  soft key to store the selected setting.
7. Press the  soft key two times to return to radio operation.



8.7 NOAA WEATHER CHANNELS

1. To receive a NOAA weather channel, press and hold the  key for 2 seconds from any channel. The transceiver will go to the last selected weather channel and the “WX” icon appears on the display.
2. Rotate the **CH** knob to select a different NOAA weather channel.
3. To exit from the NOAA weather channels, press and hold the  key. The transceiver returns to the channel it was on prior to a weather channel and the “WX” icon disappears from the display.

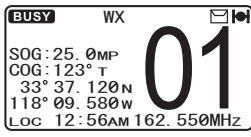

8.7.1 NOAA Weather Alert

In the event of extreme weather disturbances, such as storms and hurricanes, the NOAA (National Oceanic and Atmospheric Administration) sends a weather alert accompanied by a 1050 Hz tone and subsequent weather report on one of the NOAA weather channels.

The **GX2200** can receive weather alerts when on a weather channel and on the last selected weather channel during scanning modes or while on another channel.

When an alert is received on a NOAA weather channel, scanning will stop and the transceiver will emit a loud beep to alert the user of a NOAA broadcast. Press any key to stop the alert and receive the weather report. Press the **QUIT** soft key to return to the last selected channel.

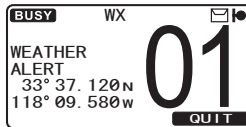

To disable the weather alert function, refer to section “11.7 WEATHER ALERT”.

NOTE

If the  key is not pressed the alert will sound for 5 minutes and then the weather report will be received.

8.7.2 NOAA Weather Alert Testing

NOAA tests the alert system every Wednesday between 11AM and 1PM. To test the **GX2200**'s NOAA weather feature, on Wednesday between 11AM and 1PM, setup as in section “8.7.1 NOAA Weather Alert” and confirm the alert is heard.

8.8 DUAL WATCH (TO CHANNEL 16)

Dual watch is used to scan two channels for communications. One channel is a normal VHF channel and the other is the priority, Channel 16. When a signal is received on the normal channel the radio briefly switches between the normal channel and Channel 16 to look for a transmission. If the radio receives communications on Channel 16 the radio stops and listens to Channel 16 until communication ends and then starts dual watch scan again.

1. Adjust the **SQL** knob until the background noise disappears.
2. Rotate the **CH** knob to select a channel you wish to watch.
3. Press one of the soft keys, then press the **DW** soft key.

The radio will monitor CH16 and the channel that was selected in step 2.

If a transmission is received on the channel selected in step 2, the **GX2200** will dual watch to CH16.

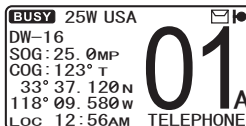

4. To stop dual watch, press one of the soft keys, then press the **DW** soft key again.

NOTE

The priority channel may be changed from CH16 to another channel. Refer to section “11.5 PRIORITY CHANNEL”.

8.9 SCANNING

The **GX2200** will automatically scan channels programmed into the preset channel memory and also the scan channel memory, and the last selected weather channel.

When an incoming signal is detected on one of the channels during scan, the radio will pause on that channel, allowing you to listen to the incoming transmission. The radio will automatically start scanning again after the transmission stops.

8.9.1 Selecting the Scan Type

1. Press and hold the **CALL MENU** key until “Setup Menu” appears.
2. Rotate the **CH** knob to select “CH FUNCTION SETUP”.
3. Press the **SELECT** soft key, then select “SCAN TYPE” with the **CH** knob.
4. Press the **SELECT** soft key.
5. Rotate the **CH** knob to select “PRIORITY SCAN” or “MEMORY SCAN”.
6. Press the **ENT** soft key to store the selected setting.
7. Press the **QUIT** soft key two times to return to radio operation.

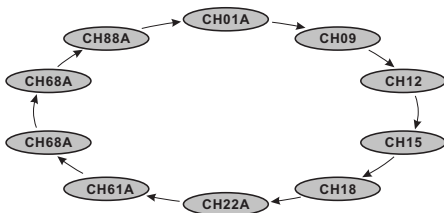
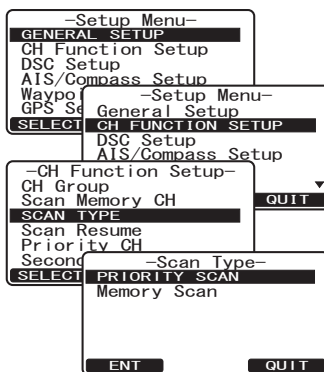

MEMORY SCAN (M-SCAN)

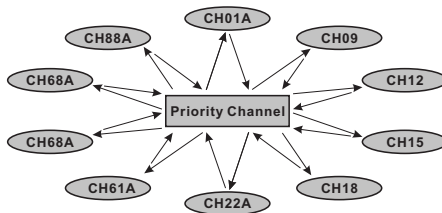



PRIORITY SCAN (P-SCAN)

8.9.2 Programming Scan Memory

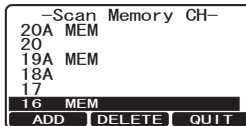
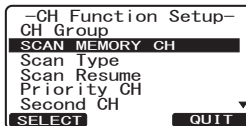
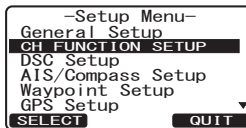
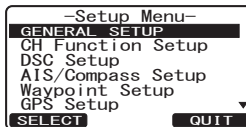
1. Press and hold the  key until "Setup Menu" appears.
2. Rotate the **CH** knob to select "CH FUNCTION SETUP".
3. Press the **SELECT** soft key, then rotate the **CH** knob to select "SCAN MEMORY CH".
4. Press the **SELECT** soft key.
5. Rotate the **CH** knob to select a desired channel to be scanned, then press the **ADD** soft key. "MEM" icon appears on the display, which indicates the channel has been selected to the scan memory.
6. Repeat step 5 for all the desired channels to be scanned.
7. To DELETE a channel from the list, select the channel then press the **DELETE** soft key. "MEM" icon disappears from the display.
8. When you have completed your selection, press the **QUIT** soft key three times to return to radio operation.



8.9.3 Memory Scanning (M-SCAN)

1. Adjust the **SQL** knob until background noise disappears.
2. Press one of the soft key, then press the **SCAN** soft key. "M-SCAN" appears on the display. Scanning will proceed from the lowest to the highest programmed channel number and preset channel (described in the next section) and will stop on a channel when a transmission is received. The channel number will blink during reception.
3. To stop scanning, press the  or  key.

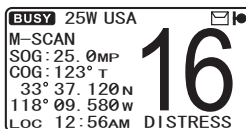

8.9.4 Priority Scanning (P-SCAN)

In the default setting, Channel 16 is set as the priority channel. You may change the priority channel to the desired channel from Channel 16 by the General Setup mode, refer to section “11.5 PRIORITY CHANNEL”.

1. Adjust the **SQL** knob until background noise disappears.

2. Press one of the soft key, then press the **SCAN** soft key. “P-SCAN” appears on the display. Scanning will proceed between the memorized channels and preset channel (described in next section) and the priority channel.

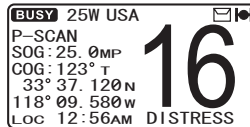

The priority channel will be scanned after each programmed channel.

3. To stop scanning, press the **16/9** or **CLR WX** key.

8.10 PRESET CHANNELS (0 ~ 9): INSTANT ACCESS

10 preset channels can be programmed for instant access. Press one of the soft keys, then press the **PRESET** soft key. Pressing the **PRESET** key activates the user assigned channel bank. If the **PRESET** soft key is pressed and no channels have been assigned, an alert beep will be emitted from the speaker.

Before beginning the Instant Access operation, assign the “PRESET” command into one of the programmable keys, refer to section “10.13 SOFT KEYS”.

8.10.1 Programming

1. Rotate the **CH** knob to select the channel to be programmed.

2. Press one of the soft keys to indicate the function on the display, then press and hold the **PRESET** soft key until the channel number blinks.

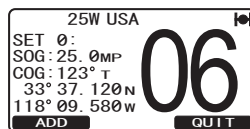

3. Rotate the **CH** knob to select the desired preset channel position (“SET 0” - “SET 9”) you wish to program.

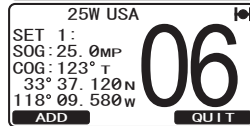

4. Press the **ADD** soft key to program the channel into the preset channel.

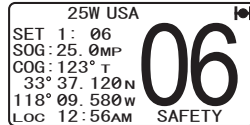

5. Repeat steps 1 through 4 to program the desired channels into the preset channels “0” ~ “9”.

8.10.2 Operation

1. Press one of soft keys, then press the **PRESET** soft key to recall the preset channel. The “**P SET**” icon will appear on the display.
2. Rotate the **CH** knob to select the desired preset channel (“0” ~ “9”). The preset channel number appears (“P-SET0” - “P-SET9”) while selecting the preset channel.
3. Press one of soft keys, then press the **PRESET** soft key to return to the last selected channel. The “**P SET**” icon will disappear from the display.

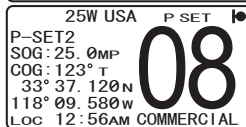
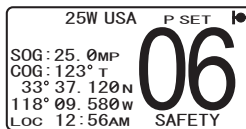

8.10.3 Deletion

1. Press one of soft keys, then press the **PRESET** soft key to recall the preset channel.
2. Rotate the **CH** knob to select the preset channel to be deleted.
3. Press one of soft keys, then press and hold the **PRESET** soft key until the channel number is blinking.
4. Press the **DELETE** soft key to delete the channel from the preset channel.
5. Repeat steps 2 through 4 to delete the desired channels from preset channels “0” ~ “9”.
6. To exit from deleting the preset channels, press the **QUIT** soft key.

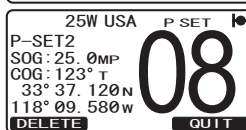
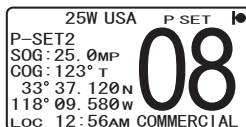

8.11 PA/FOG OPERATION

The **GX2200** has a 30W hailer built-in and can be used with any 4 Ohm PA horn. Standard Horizon offers two HAIL/PA horns, the **220SW** (5" round 30 Watt HAIL/PA horn) and the **240SW** (5" x 8" rectangular 40 Watt HAIL/PA horn). When the **GX2200** is in PA Hail mode the PA speaker listens back (acts as a microphone and provides two-way communications through the PA horn to the main radio).

NOTE

When in the PA HAIL or FOG HORN mode, the **GX2200** will continue to receive DSC calls and communications on the last selected working channel prior to entering the PA HAIL or FOG HORN mode. Then the **GX2200** AIS page can also be accessed when in the PA HAIL or FOG HORN mode.

PA HAIL mode:

PA HAIL mode allows the transceiver to be used as a power hailer when an optional STANDARD HORIZON **220SW** or **240SW** HAIL/PA horn is installed. The PA Hail mode has a listen-back feature which provides two way communication through the HAIL/PA horn.

FOG HORN mode:

Automatic signaling is transmitted through the HAIL/PA horn. When the fog horn, bells or whistle signal is not being outputted the **GX2200** listens back through the connected PA horn.

8.11.1 Operating the PA HAIL mode

1. Press one of the soft keys, then press the **PA/FOG** soft key.

Note: The **NEXT** soft key may have to be pressed to see the **PA/FOG** soft key if the soft keys have not be customized.

2. Rotate the **CH** knob to select "PA", then press the **SELECT** soft key.
3. Press the **PTT** switch to speak through the HAIL/ PA speaker.

Rotate the **CH** knob to control the AF output level. The AF output level can be set from 0 to 30 watts.

4. To listen back, rotate the **PWR/VOL** knob.
5. To exit the PA HAIL mode, press the **CLR WX** key.

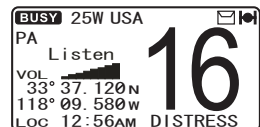

NOTE



When in the PA HAIL mode it is possible to simultaneously use the AIS page by pressing the  key.

8.11.2 Operating the FOG HORN mode

The user can select the type of horn from “Underway”, “Stop”, “Sail”, “Tow”, “Aground”, “Anchor”, “Horn”, and “Siren”.

1. Press one of the soft keys, then press the  soft key.

Note: The  soft key may have to be pressed to see the  soft key if the soft keys have not be customized.

2. Rotate the **CH** knob to select “FOG”, then press the  soft key.
3. Rotate the **CH** knob to select one of the eight functions described above.
4. Press the  soft key.

5. On the “Horn” and “Siren” modes, press the **PTT** switch to activate the tone through the HAIL/PA speaker.

Rotate the **CH** knob to control the AF output level. The AF output level can be set from 0 to 30 watts.

6. To listen back, rotate the **PWR/VOL** knob.
7. To exit the FOG HORN mode, press the  key.

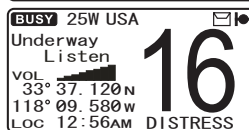

NOTE

When in the FOG HORN mode it is possible to simultaneously use the AIS page by pressing the  key.

8.11.3 Fog Signal Timing Chart

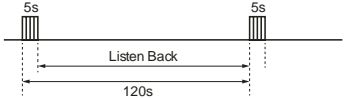
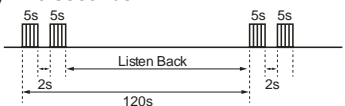
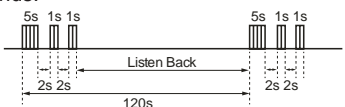
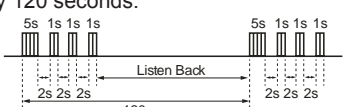
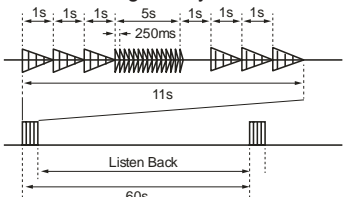
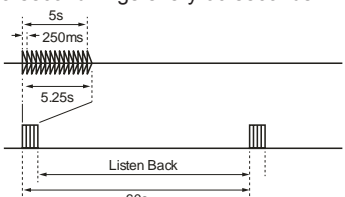
TYPE	PATTERN	USAGE
UNDERWAY	<p>One 5-second blasts every 120 seconds.</p> 	<p>Motor vessel underway and making way.</p>
STOP	<p>Two 5-second blasts (separated by 2 seconds) every 120 seconds.</p> 	<p>Motor vessel underway but stopped (not making way).</p>
SAIL	<p>One 5-second blasts followed by two 1-second blasts (separated by 2 seconds) every 120 seconds.</p> 	<p>Sailing vessel underway, fishing vessel (underway or anchored), vessel not under command, a vessel restricted in her ability to maneuver (underway or at anchor), or a vessel towing or pushing another ahead.</p>
TOW	<p>One 5-second blasts followed by three 1-second blasts (separated by 2 seconds) every 120 seconds.</p> 	<p>Vessel under tow (manned).</p>
AGROUND	<p>One 11-second rings every 60 seconds.</p> 	<p>Vessel is aground.</p>
ANCHOR	<p>One 5-second rings every 60 seconds.</p> 	<p>Vessel is at anchor.</p>

8.12 INTERCOM OPERATION

To access the following intercom functions one of the soft keys must be setup as “IC”. Refer to section “10.13 SOFT KEYS”.

In addition an optional **RAM3** remote station microphone (e.g. **CMP30**) must be connected to perform intercom functions between the **GX2200** and the **RAM3**.

8.12.1 Communication

1. Press one of the soft keys, then press the **IC** soft key to enable the intercom mode.

Note: Depending on the programming of the

IC soft key, the **NEXT** soft key may have to be pressed to see the **IC** soft key.

2. When the intercom mode is enabled, “Intercom” is displayed on the radio and **RAM3**.

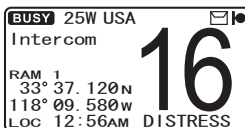

3. Press the **PTT** switch on the radio. “Talk” will be shown on the display.

Note: A warning beep will be heard when the radio’s **PTT** and **RAM3**’s **PTT** switches are pushed at the same time.



(GX2200’s PTT switch is pressed)

4. Speak slowly and clearly into the microphone, hold the microphone about 1/2” (1.5 cm) away from your mouth.



(RAM3’s PTT switch is pressed)

5. When finished, release the **PTT** switch.
6. Press the **CLR WX** key to exit intercom mode and revert to radio mode.

8.12.2 Calling

Pressing and holding the **IC** soft key when in intercom mode on either the radio or **RAM3** microphone will produce a calling beep to the other station.

8.13 VOICE SCRAMBLER

If privacy of communications is desired, a **CVS2500** 4-code voice scrambler (VS) can be installed in the transceiver. Contact your Dealer to have a **CVS2500** installed. Refer to the section “**11.9 SCRAMBLER SETUP**” to program the voice scrambler.

1. Select a channel that was programmed for scrambler mode (“Vs” and scrambler number will appear on the display).
2. Monitor the channel before transmitting.
3. Transmit the voice message. The signal sent will be scrambled.

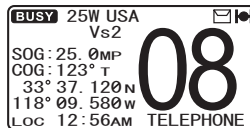

8.14 DEMO MODE

This mode is used by Standard Horizon sales persons and dealers to demonstrate radio, DSC and AIS functions. Demo mode allows latitude, longitude and time to be entered to simulate radio displays. When the demo mode is enabled, the radio display will automatically switch from the NORMAL, COMPASS, AIS and WAYPOINT displays.

NOTE

When demo mode is enabled and the radio is turned off and back on the radio will still be in the demo mode.

1. Press and hold the **CALL MENU** key until "Setup Menu" appears.
2. Rotate the **CH** knob to select "DEMO MODE".
3. Press the **SELECT** soft key, then select "POS INPUT" with the **CH** knob.
4. Press the **SELECT** soft key.
5. Enter the latitude/longitude of your vessel and your local UTC time in the 24-hour notation by the **CH** knob. Rotate the **CH** knob to select the number and press the **ENT** soft key to move the cursor to the next character. You may backspace the cursor by pressing the **BACK** soft key, if you make a mistake.
6. To store the data entered, press and hold the **ENT** soft key.
7. Rotate the **CH** knob to "DEMO START" and press the **SELECT** soft key.
8. Select "START" using the **CH** knob and press the **ENT** soft key.

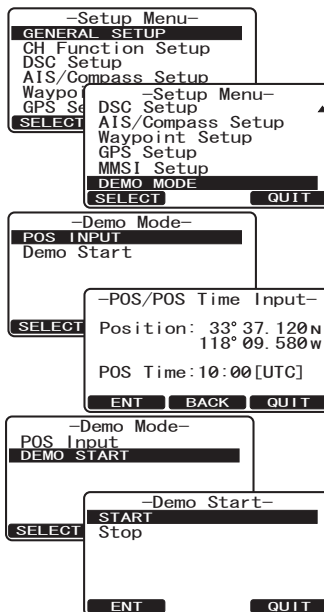

NOTE

To stop the demo mode, select "STOP" in step 8 above.

9 DIGITAL SELECTIVE CALLING (DSC)

9.1 GENERAL

WARNING

This **GX2200** is designed to generate a digital maritime distress and safety call to facilitate search and rescue. To be effective as a safety device, this equipment must be used only within communication range of a shore-based VHF marine channel 70 distress and safety watch system. The range of signal may vary but under normal conditions should be approximately 20 nautical miles.

NOTE

A DSC Warning sticker is included with the **GX2200**. To comply with FCC regulations this sticker must be mounted in a location that can be easily viewed from the location of the **GX2200**.

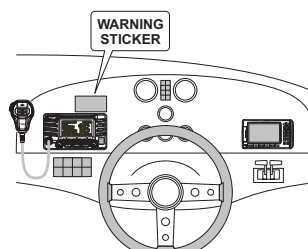

Digital Selective Calling (DSC) is a semi-automated method of establishing a radio call, it has been designated by the International Maritime Organization (IMO) as an international standard for establishing VHF, MF and HF radio calls. It has also been designated as part of the Global Maritime Distress and Safety System (GMDSS). It is planned that DSC will eventually replace aural watches on distress frequencies and will be used to announce routine and urgent maritime safety information broadcasts.

This system allows mariners to instantly send a distress call with GPS position (when connected to the transceiver) to the Coast Guard and other vessels within range of the transmission. DSC will also allow mariners to initiate or receive Distress, Urgency, Safety, Routine, Position Request, and Position Report, Automatic Position Polling, and Group calls to or from another vessel equipped with a DSC transceiver.

9.2 MARITIME MOBILE SERVICE IDENTITY (MMSI)

9.2.1 What is an MMSI?

An MMSI is a nine digit number used on marine transceivers capable of using Digital Selective Calling (DSC). This number is used like a telephone number to selectively call other vessels.

THIS NUMBER MUST BE PROGRAMMED INTO THE RADIO TO OPERATE DSC FUNCTIONS.

How can I obtain an MMSI assignment?

In the USA, visit the following websites to register:

<http://www.boatus.com/mmsi/>

http://seatow.com/boating_safety/mmsi.asp

<http://www.usps.org/php/mmsi/rules.php>







In Canada, visit

<http://www.ic.gc.ca/epic/site/smt-gst.nsf/en/sf01032e.html>

9.2.2 Programming the MMSI

WARNING

The MMSI can be inputted only once. Therefore please be careful not to input the incorrect MMSI number. If you need to change the MMSI number after it has been entered, the radio will have to be returned to Factory Service. Refer to the section “17.2 FACTORY SERVICE.”

1. Press and hold the  key until “Setup Menu” appears.
2. Rotate the **CH** knob to select “MMSI SETUP”.
3. Press the  soft key. (To cancel, press the  soft key.)
4. Rotate the **CH** knob to select the first number of your MMSI, then press the  soft key to step to the next number.
5. Repeat step 4 to set your MMSI number (nine digits).
6. If a mistake was made entering in the MMSI number, press the  soft key until the wrong number is selected, then rotate the **CH** knob to correct the entry and press the  soft key.
7. When finished programming the MMSI number, press and hold the  soft key. The radio will ask you to input the MMSI number again. Use steps 4 through 6 above.

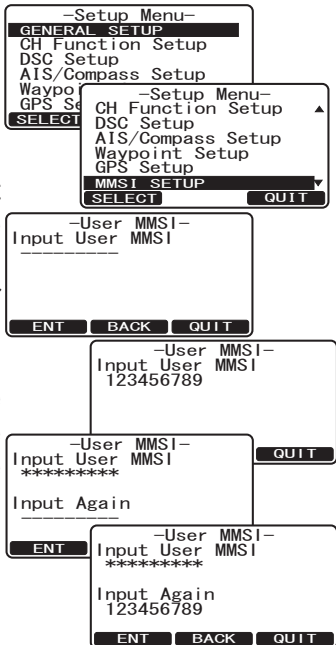

8. After the second number has been input, press and hold the **CH** knob to store the MMSI.
9. Press the **OK** soft key to return to radio operation.

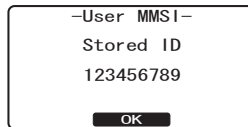

NOTE

To view your MMSI after programming to ensure it is correct, perform steps 1~3. Look that the MMSI number shown on the display is correct.

9.3 DSC DISTRESS CALL

The **GX2200** is capable of transmitting and receiving DSC distress messages to all DSC radios. The **GX2200** may be connected to a GPS to also transmit the latitude and longitude of the vessel.

9.3.1 Transmitting a DSC Distress Call

NOTE

To be able to transmit a DSC distress call an MMSI number must be programmed, refer to section “9.2.2 Programming the MMSI.”

In order for your ships location to be transmitted, the internal GPS must be able to receive a fix or a optional GPS antenna or chart plotter must be connected. Refer to section “6.5 ACCESSORY CABLES.”

Basic Operation

1. Lift the red spring loaded DISTRESS cover, and press and hold the **(DISTRESS)** key. The radio’s display will count down (3-2-1) and then transmit the distress call. The backlight of the display and keypad flashes while the radios display is counting down.
2. When the distress signal is sent, the transceiver watches for a transmission between CH16 and CH70 until an acknowledgment signal is received.
3. If no acknowledgment is received, the distress call is repeated in 4 minute intervals until a DSC acknowledgment is received.

