

YAESU

AIR BAND TRANSCEIVER

FTA-250L

Operating Manual

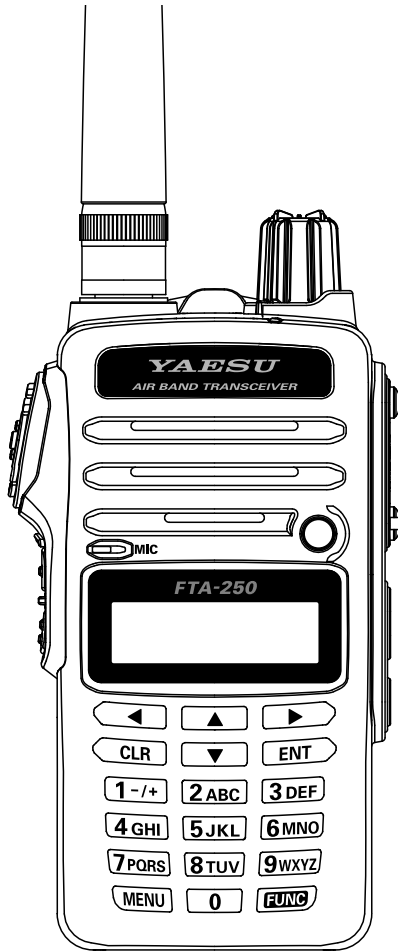

CONTENTS

Important Notice!	1	Weather alert reception.....	20
Introduction	2	Dual Watch Operation.....	21
Accessories and Options	3	Setting the P-ch.....	21
Supplied Accessories.....	3	Starting the dual watch.....	21
Available Options.....	3	Noise Cancellation.....	22
Safety Precautions	4	TOT Feature.....	22
Controls & Connectors (Top / Front Panel)	7	Battery Saver during Reception.....	23
Controls & Connectors (Left / Right Side)	8	Using the Headset Microphone.....	23
Controls & Connectors (LCD)	9	VOX Operation.....	24
Before You Begin	10	Side Tone Control.....	25
Antenna Installation.....	10	Lock Function.....	25
Installing the Battery Pack.....	10	PTT Lock Function.....	26
Removing the Battery Pack.....	10	ANL Feature.....	26
Battery Charging.....	10	Changing the Channel Steps.....	27
Low Battery Indication.....	11	Function Modes.....	28
External DC Power Supply Connection.....	12	Memory Operation	29
Belt Clip Installation.....	12	Recalling the Memories.....	29
Headset Connection.....	13	Instant Storage.....	30
Precautions.....	13	Maintenance of the Memory.....	30
Basic Operation	14	Scanning Operation	32
Turning the power on and off.....	14	Scanning Channels.....	32
Adjusting the squelch.....	14	Scanning the Specified Channels.....	33
Monitor Switch.....	15	SETUP Mode	34
Adjusting the frequency.....	15	Basic Operation.....	34
Accessing the 121.5 MHz Emergency Frequency.....	16	Maintenance of the Memory.....	35
Transmission.....	16	Setting of the COMM SETUP Mode Operation.....	35
Resetting the Transceiver.....	16	PRIORITY CH.....	37
Operation Modes.....	17	Setting of the Operation and.....	37
BASIC OPERATION OF THE MENU MODE.....	18	Configuration of the Transceiver.....	37
Advanced Operation	19	About the Transceiver.....	38
Pitch Control.....	19	Summary of the SETUP Menu.....	39
Flip-Flop Feature (Frequency Recall).....	19	Specifications	41
Reception of Weather Channel Broadcasts.....	20	Troubleshooting For Headset Connection	42

IMPORTANT NOTICE!

FCC RF Exposure Compliance Requirements for Occupational Use Only:

The **FTA-250L** has been tested and complies with the Federal Communications Commission (FCC) RF exposure limits for Occupational Use/Controlled Exposure Environment. In addition, the radio complies with the following Standards and Guidelines:

- ❑ FCC 96-326, Guidelines for Evaluating the Environmental Effects of Radio-Frequency Radiation.
- ❑ FCC OET Bulletin 65 Edition 97-01 (1997) Supplement C, Evaluating Compliance with FCC Guidelines for Human Exposure to Radio Frequency Electromagnetic Fields.
- ❑ ANSI/IEEE C95.1-1992, IEEE Standard for Safety Levels with Respect to Human Exposure to Radio Frequency Electromagnetic Fields, 3 kHz to 300 GHz.
- ❑ ANSI/IEEE C95.3-1992, IEEE Recommended Practice for the Measurement of Potentially Hazardous Electromagnetic Fields - RF and Microwave.
- **This radio is NOT approved for use by the general population in an uncontrolled environment. This radio is restricted to occupational use, work related operations only where the radio operator must have the knowledge to control its RF exposure conditions.**
- **When transmitting, hold the radio in a vertical position with its microphone 1 to 2 inches (2.5 to 5 cm) away from your mouth and keep the antenna at least 1 inch (2.5 cm) away from your head and body.**
- **The radio must be used with a maximum operating duty cycle not exceeding 50%, in typical Push-to-Talk configurations. DO NOT transmit for more than 50% of total radio use time (50% duty cycle). Transmitting more than 50% of the time can cause FCC RF exposure compliance requirements to be exceeded.**
The radio is transmitting when the  icon is displayed on the upper left corner of the screen of the radio. You can cause the radio to transmit by pressing the PTT button.
- **Always use YAESU authorized accessories.**

NOTICE

There are no user-serviceable points inside this transceiver.
All service jobs must be referred to your Authorized Service Center.

INTRODUCTION

The YAESU **FTA-250L** is ultra compact, stylish, solid hand-held transceivers providing communication (transmit and receive) capability on the International Aircraft Communication Band (“COM” band: 118 to 136.975 MHz).

The **FTA-250L** includes NOAA weather band monitoring and 250 memory channels. The channel configurations can be easily reprogrammed in minutes using the optional PC Programming Software and your PC.

We recommend that you read this manual in its entirety, so as to understand the many features of the **FTA-250L** completely. Keep this manual handy, so you may use it for reference.

Congratulations!

You now have at your fingertips a valuable communications tool, a YAESU two-way radio! Rugged, reliable and easy to use, your YAESU radio will keep you in constant touch with your friends and colleagues for years to come, with negligible maintenance or down-time.

Please take a few minutes to read this manual carefully. The information presented here will allow you to derive maximum performance from your radio, in case questions arise later on.

We're glad you joined the YAESU team. YAESU products cover the entire spectrum of radio communications applications, and our worldwide support network is here to serve you. Let us help you get your message across.

ACCESSORIES AND OPTIONS

Supplied Accessories

Lithium-ion Battery Pack	SBR-25LI
AC Adapter	SAD-20
Charger Cradle	SBH-22
Cigarette Lighter DC/DC Converter	SDD-12
Helical Antenna	SRA-18A*
	or
	YHA-73
Headset Adapter Cable	SCU-15
Belt Clip	SHB-18
Ferrite Core	L9190192
Operating Manual	
Warranty Card	

* Antenna gain: 2.15 dBi
Impedance: 50 ohms

Available Options

Speaker Microphone	SSM-10A
Earphone (available only with the SSM-10A)	SEP-10A
Earphone	SEP-11A
Li-Ion Battery Pack (7.4 V, 1,950 mAh)	SBR-25LI
Li-Ion Battery Pack (7.4 V, 2,500 mAh)	SBR-26LI
AC Adapter	SAD-20
Charger Cradle	SBH-22
Cigarette Lighter DC/DC Converter	SDD-12
Helical Antenna	SRA-18A
Belt Clip	SHB-18
Headset Adapter Cable	SCU-15
USB Programming and Control Cable	USB-57B

Availability of accessories may vary. Some accessories are supplied as standard per local requirements, while others may be unavailable in some regions. Consult your YAESU Dealer for details regarding these and any newly-available options.



Connection of any non-YAESU-approved accessory, should it cause damage, may void the Limited Warranty for the FTA-250L.

SAFETY PRECAUTIONS





Be sure to read the safety precautions to use this product safely.

Yaesu is not liable for failures and other problems caused due to misuse or use of this product by you or a third party. Also, Yaesu is not liable for damages caused through use of this product by you or a third party except in the case where ordered to pay for damages under the laws.



Type and meaning of the marks

	DANGER	Indicates an imminently hazardous situation which, if not avoided, could result in death or serious injury.
	WARNING	Indicates a potentially hazardous situation which, if not avoided, could result in death or serious injury.
	CAUTION	Indicates a potentially hazardous situation which, if not avoided, may result in minor or moderate injury or only property damage.

Type and meaning of symbols

	Indicates a prohibited action, not to be done in order to use this product safely. For example,  indicates that the product should not be disassembled.
	Indicates a required action, to be done in order to use this product safely. For example,  indicates that the power plug should be re-moved.





	Do not use this product in “an area where use of it is prohibited”, e.g., inside the hospital or train.” This product can affect electronic or medical devices.
	Do not use this product while riding a bicycle or driving a car. Accidents can result. Be sure to stop the bicycle or car at a safe place before using this product.

 **Do not perform transmission in a crowded place for the safety of persons using a medical device such as a cardiac pacemaker.**
The radio wave emitted from this product can cause the medical device to malfunction and result in an accident.

 **Do not touch any material leaking from the battery pack with bare hands.**
The chemical that has stuck to your skin or entered your eye can cause chemical burns. In such a case, consult the doctor immediately.

 **Those who are carrying a medical device such as a cardiac pacemaker should not perform transmission near the device. When transmitting, use an external antenna and keep as far as possible away from the external antenna.**
The radio wave emitted by the transmitter can cause the medical device to malfunction and result in an accident.

 **Do not use this product or the battery charger in a place where inflammable gas is generated.**
A fire or explosion can occur.

 **Do not solder or short-circuit the terminal of the battery pack.**
A fire, leak, overheating, explosion, or ignition can result. Do not carry the battery pack together with a necklace, hair pin, or small metal objects. A short circuit can result.



 **Do not power this transceiver with a voltage other than the specified power supply voltage.**
A fire, electric shock, or damage may result.

SAFETY PRECAUTIONS



Do not use the battery pack for any model other than the specified transceiver.

A fire, leak, overheating, explosion, or ignition can result.



Do not make very long transmissions.

The main body of the transceiver may overheat, resulting in a failure or burns.



Do not disassemble or make any alteration to this product.

An injury, electric shock, or failure can result.



Keep the terminals of the battery pack clean.

If terminal contacts are dirty or corroded, a fire, leak, overheating, explosion, or ignition can result.



Do not handle the battery pack or charger with wet hands. Do not insert or remove the power plug with wet hands.

An injury, leak, fire, or failure can result.



If smoke or strange odor is emitted from the main body, battery pack, or battery charger, immediately turn the transceiver off; remove the battery pack, and remove the power plug from the outlet.

A fire, leak, overheating, damage, ignition, or failure can result. Contact the dealer from which you purchased this product or Yaesu Customer Support.



Do not use the battery pack which is externally damaged or deformed.

A fire, leak, heating, explosion, or ignition can result.



Do not use any battery charger which is not specified by Yaesu.

A fire or failure can result.



When transmitting, keep the transceiver at least 5.0 mm (3/16 inch) away from your body. Use only the supplied antenna. Do not use modified or damaged antennas.



If charging of the battery pack cannot be completed within the specified charging time, immediately remove the power plug of the battery charger from the outlet.

A fire, leak, overheating, explosion, or ignition can result.



CAUTION



Do not dangle or throw this product by holding its antenna.

This product can hit and injure someone. In addition, doing so can result in a transceiver failure or damage.



Do not use transceiver in a crowded place.

The antenna can hit someone, resulting in an injury.



Do not place this transceiver in a place subject to direct sun-light or near a heater.

The transceiver can deform or discolor.



Do not place this transceiver in a humid or dusty place.

A fire or failure can result.



During transmission, keep the antenna as far from you as possible.

Long-time exposure to electromagnetic waves can have a negative impact on your health.



Do not clean the case with thinner or benzene.

Use a soft, dry cloth to clean the case.



If the transceiver is not being used for an extended period, turn it off and remove the battery pack for safety.



Do not drop, strike, or throw the transceiver.

A failure or damage may result.



Keep magnetic cards and video tape away from the transceiver.

The data recorded on cash cards or video tape can be erased.



Charge the battery pack within the temperature range from +5 °C to +35 °C (+41 °F to +95 °F).

Charging the battery pack outside this temperature range can cause leak, overheating, decrease in performance, or reduction in service life can result.

SAFETY PRECAUTIONS



When unplugging the power cord of the battery charger, be sure to hold the power plug.

Pulling the power cord can damage it and cause a fire or electronic shock.



Do not use the earphones or head-phones at an extremely high volume level.

Hearing impairment can result.



Keep this product out of reach of children.

An injury, etc. can result.



Install the belt clip securely.

If they are installed improperly, the FTA-250L may fall or drop, resulting in an injury or damage.



Do not place a heavy object on the power cord of the battery charger.

The battery cord can be damaged, resulting in a fire or electric shock.



Do not use the included battery charger to charge any battery pack which is not specified for use with the charger.

A fire can result.



Do not operate the transmitter near the TV or radio.

Radio disturbance can occur in the transceiver, the TV, or the radio.



Do not use any products other than the specified options and accessories.

A failure can result.



When the battery charger is not in use, remove its power plug from the outlet.



Before discarding the worn battery pack, affix tape or the like to its terminals.



Before using this transceiver in a hybrid or fuel-saving car, be sure to check with the auto-mobile manufacturer regarding use of the transceiver in that car.

Noise generated by an onboard electrical device (inverter, etc.) can disrupt the normal operation of the transceiver.

CONTROLS & CONNECTORS (TOP / FRONT PANEL)

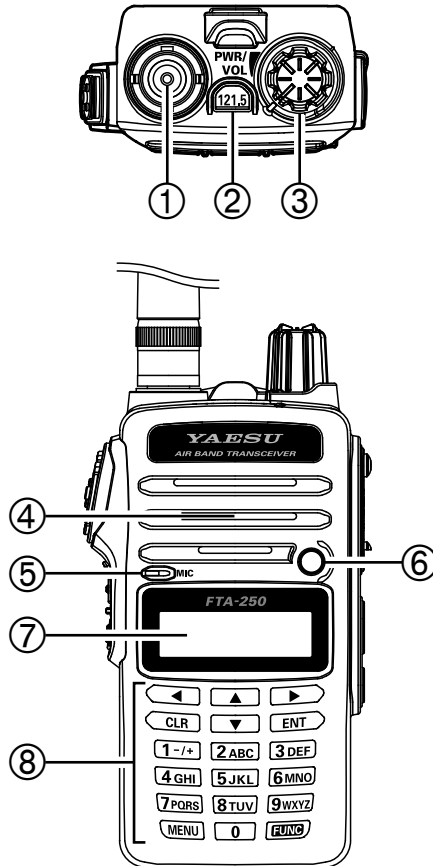

- ① **Antenna Jack**
This BNC connector accepts the supplied flexible antenna or another antenna designed to provide a 50-Ohm impedance on the Aircraft Communication Band.
- ② **121.5 Key**
Press and hold this key to access the emergency frequency (121.5 MHz) instantly.
- ③ **PWR/VOL Knob**
Turn this control clockwise to turn the transceiver ON and to increase the volume. Counter-clockwise rotation to reduce the volume and turn the transceiver OFF.
- ④ **Loudspeaker**
The internal speaker is located here.
- ⑤ **Microphone**
To transmit, speak into the mic opening into this opening in a normal voice level, while pressing the PTT switch.
- ⑥ **LED Flash-Light**
- ⑦ **LCD (Liquid Crystal Display)**
The display shows current operating condition.
- ⑧ **Keypad**
These 18 keys select the important operating functions of the **FTA-250L**.

CONTROLS & CONNECTORS (LEFT / RIGHT SIDE)

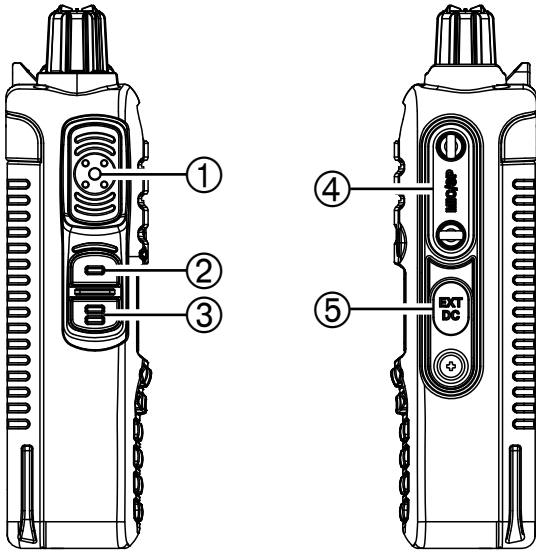

① PTT (Push To Talk) Switch

Press this switch to transmit, and release it to receive after your transmission is completed.

② SQL (Squelch) key

This key may be pressed to adjust the squelch level. Press this key for 1 second to “open” the squelch continuously. Press this button again to resume normal (quiet) monitoring.

③ LOCK key

Press and hold this key to lock the keypad. To unlock, repeat this process.

④ MIC/SP Jack

You may connect the supplied **SCU-15** Headset Adapter Cable or the optional **SSM-10A** Speaker/Microphone to this jack. To use this jack, you must first remove the cover from the transceiver body.

 **Do not allow the FTA-250L to get wet while the MIC/SP cover has been removed.**

⑤ EXT/DC Jack

When an external 9.0 to 10.5-Volt DC power source is available, you may connect the SDD-12 Cigarette Lighter DC/DC Converter here.

 **1) Do not allow the FTA-250L to get wet while the rubber cover is removed.**
2) Do not connect any accessory unapproved by YAESU to supply DC power.

CONTROLS & CONNECTORS (LCD)

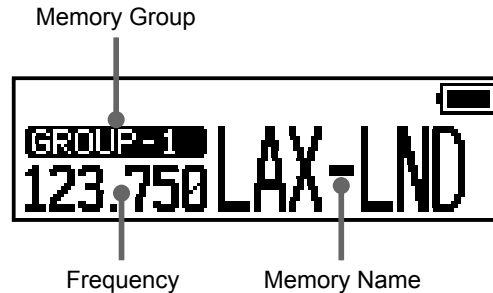
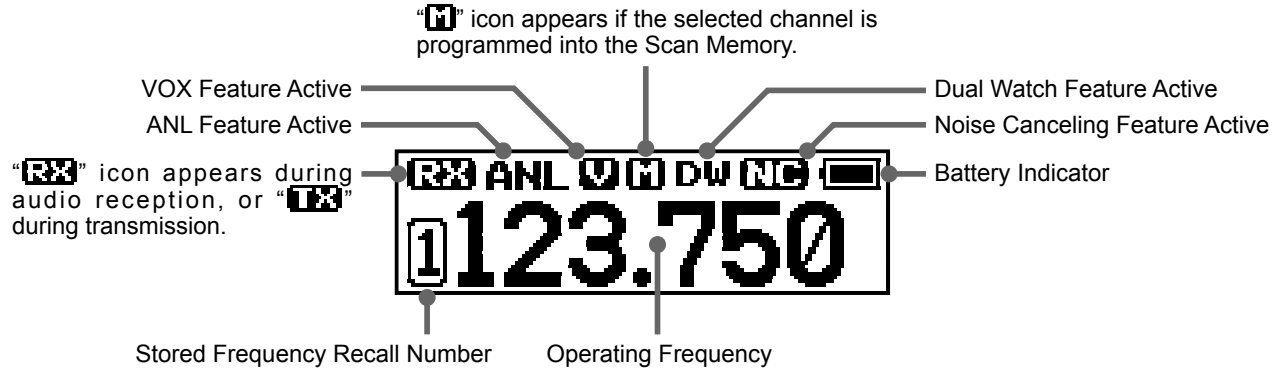

BEFORE YOU BEGIN

Antenna Installation

To attach the supplied antenna to the **FTA-250L**, grasp the base of the antenna firmly, and exert a moderate “pinching” pressure on the base as you press the antenna onto the transceiver’s antenna connector. While exerting this pressure, rotate the antenna clockwise 1/4 turn to lock the antenna in place.

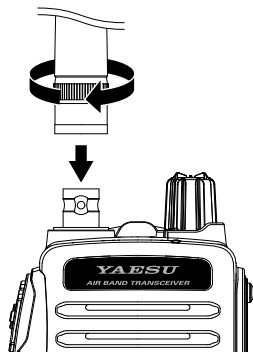

Installing the Battery Pack

1. Insert the battery pack into the battery compartment on the back of the transceiver (①).
2. Push the battery in until the battery latch on the lower back side of the transceiver clicks securely (②).

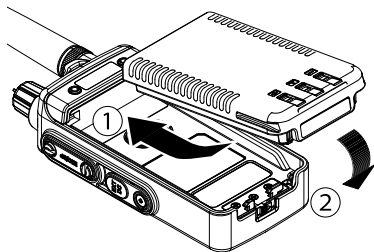

Removing the Battery Pack

1. Turn the transceiver OFF.
2. While sliding the latch in the direction of the arrow, as shown in the illustration.
3. Pull out the battery pack from the transceiver.

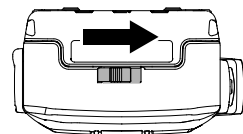

Battery Charging

It is necessary to charge the Lithium-ion battery fully before its first use. Follow the procedure below:

1. Install the Lithium-ion battery pack onto the transceiver. Ensure that the transceiver is switched off.
2. Insert the cable plug of the **SAD-20** AC Adapter into the DC IN jack located on the back of the **SBH-22** Charger Cradle, then plug the **SAD-20** into the AC line outlet.
3. Insert the transceiver into the **SBH-22** Charger Cradle.
 - If the transceiver is inserted correctly, the RED indicator on the **SBH-22** will glow.
 - You may insert the cable plug of the **SDD-12** Cigarette Lighter DC/DC Converter into the **EXT/DC** jack located on the right side of the transceiver. In this case, the “” icon will appear in the top right corner of the LCD display for trickle charging.

BEFORE YOU BEGIN

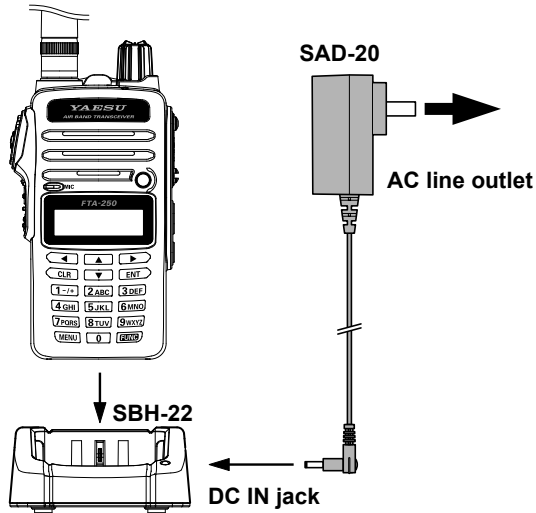

- A fully-discharged **SBR-25LI** Battery Pack will be charged completely in about 3.5 hours (depending on the battery being charged), and then the GREEN indicator on the **SBH-22** will glow letting you know the battery has been fully charged.
- The **SAD-20** is not designed to power the transceiver for operation (reception or transmission).





4. When charging is complete, disconnect the **SAD-20** from the DC IN jack and the AC line outlet.

Low Battery Indication

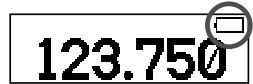
As the battery discharges during use, the voltage will gradually become lower.

When the battery voltage is too low for reliable operation, the “” icon will blink on the LCD display, indicating that the battery pack must be recharged before further use.



Icons	Description
	Full battery power
	Enough battery power
	Low battery power
	Poor battery power
 (w/blink)	Charge (or replace) the battery

- Avoid recharging Li-Ion batteries before the “” indicator is observed, as this can degrade the charge capacity of your Li-Ion battery pack.
- The fully-charged battery lasts for 16 hours on the **FTA-250L** under the conditions below:
 Battery saver :ON
 Operation ratio:TX:RX:Standby=5:5:90 (duty cycle)

BEFORE YOU BEGIN

External DC Power Supply Connection

You may insert the cable plug of the **SDD-12** Cigarette Lighter DC/DC Converter into the **EXT DC** jack located on the right side of the transceiver.

In this case, the "🔌" icon will appear in the top right corner of the LCD display.

When making DC connections via the **SDD-12**, be absolutely certain to observe the proper voltage level and polarity guidelines.

- ❑ The **SDD-12** can be connected to 12 to 24 Volt DC power sources.

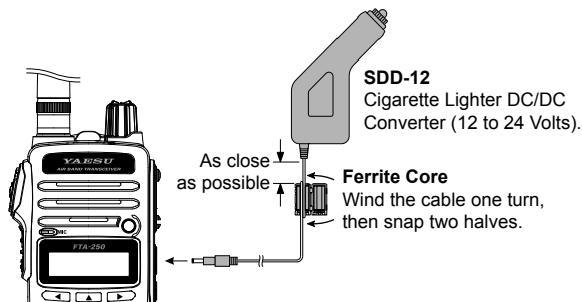

- ❑ For noise reduction from exogenous noise, wind one turn of the **SDD-12** cable around the ferrite core, and snap its two halves together, per the illustration above. Attach the ferrite core as close as possible to the **SDD-12** body, as shown.



Do not connect any accessory unapproved by YAESU to supply DC power; otherwise the FTA-250L may be damaged.

Belt Clip Installation

You may mount the belt clip to the rear of the **FTA-250L** using the supplied screws.

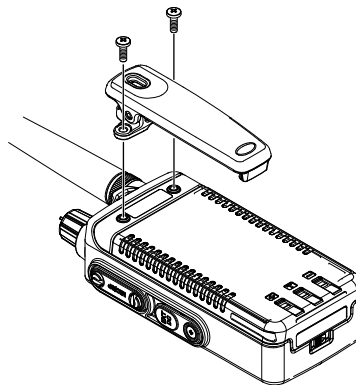

BEFORE YOU BEGIN

Headset Connection

You may connect an optional headset using the supplied **SCU-15** Headset Adapter Cable.

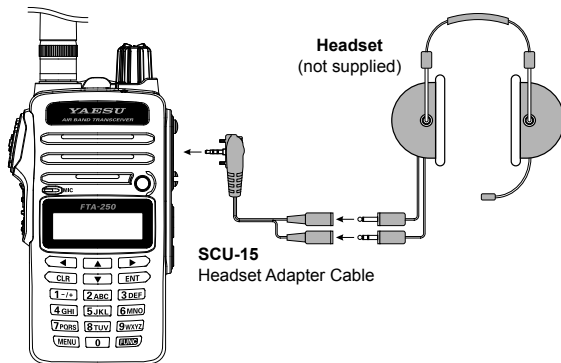

1. Remove the two screws and cover of the **MIC/SP** jack located on the right side of the transceiver.
2. Insert the plug of the **SCU-15** to the **MIC/SP** jack.
3. Fix the plug with two screws attached to the **SCU-15**.
 - Either of the plug directions are acceptable as long as the both screws fit the screw holes.
4. Insert the plugs of the headset to the sockets of the **SCU-15**.

Precautions

- The **FTA-250L** is capable of two-way communication on channels used for critical aviation safety communications. Therefore, it is important that this transceiver be kept away from children or other unauthorized users at all times.
- Do not dispose of the Lithium-ion battery pack in a fire. Do not carry a Lithium-ion battery pack in your pocket, where keys or coins could short the terminals. This could create a serious fire/burn danger, and possibly cause damage to the Lithium-ion pack.
- The **FTA-250L** is designed to have the waterproof capability equivalent to IP54. Do not allow the transceiver to become submerged, and do not subject it to water spray under pressure.

BASIC OPERATION

Turning the power on and off

1. Rotate the PWR/VOL knob out of the click-stop to turn the transceiver ON.
2. To turn the transceiver OFF, turn the PWR/VOL knob fully counter-clockwise into the click-stop position.

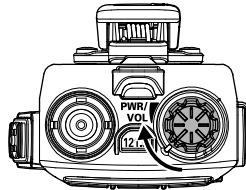

- The "RX" icon appears on the display when the audio signal is received on the current frequency.

Adjusting the volume

1. Rotate the PWR/VOL knob to adjust the receiver volume.

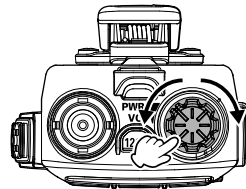

Adjusting the squelch

1. Press the **SQL** key, then press the [◀] or [▶] key to adjust to a squelch level (OFF to 15) at which the background noise is muted.
2. Press the **SQL** key to save the squelch setting and return to normal operation.

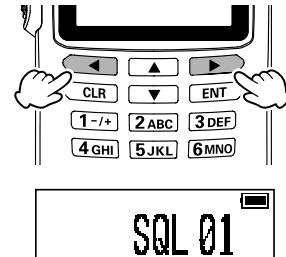
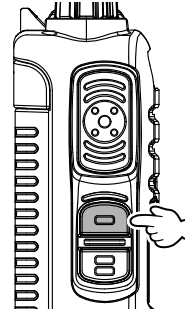

BASIC OPERATION

Monitor Switch

When listening to a very weak signal from an aircraft or ground station, you may observe the signal disappearing periodically as the incoming signal strength becomes too weak to override the squelch threshold setting.

To disable the squelch temporarily;

1. press and hold the **SQL** key for 1 second.
The squelch will remain open and you should have a better chance of hearing weak signals.
2. To return to normal operation, press the **SQL** key momentarily.

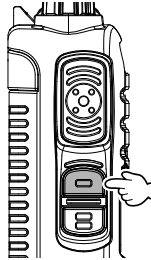

Adjusting the frequency

- Pressing the [▶] tunes the **FTA-250L** toward a higher frequency, while pressing the [◀] will lower the operating frequency, in steps pre-programmed for the current operating band.
- Directly entering frequencies from the keypad is the easiest method if you know the frequency on which you wish to operate. Just enter the five digits of the frequency to move to that frequency.

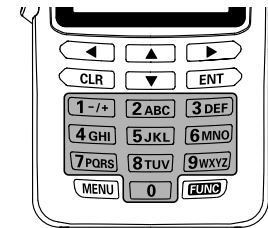
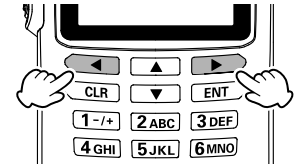

For example, to set 134.35 MHz, press [1] ➡ [3] ➡ [4] ➡ [3] ➡ [5].

To set 118.275 MHz, you do not need to press the final "5" in the frequency as below:

[1] ➡ [1] ➡ [8] ➡ [2] ➡ [7].

BASIC OPERATION

Accessing the 121.5 MHz Emergency Frequency

The **FTA-250L** can quickly access the 121.500 MHz emergency frequency. This function can be activated even when the keypad lock function (described on page 25) is in use.

1. Press and hold the [121.5] key.

After four beeps, the transceiver enters the emergency mode and the frequency is automatically tuned to 121.500 MHz.

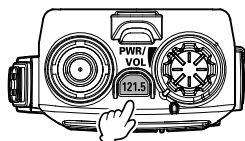

2. To exit the emergency mode, press the [CLR] key.

The message confirming the cancelation of the emergency mode will appear.

3. Press the [◀] key to select "YES", then press the [ENT] key.

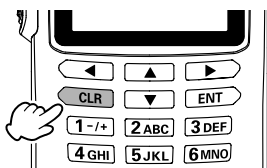

Transmission

1. Press and hold the **PTT** switch.

The "TX" icon will appear on the display during transmission.

2. Speak into the microphone area on the front panel of the radio in a normal voice level.
3. To return to the receive mode, release the **PTT** switch.

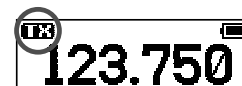
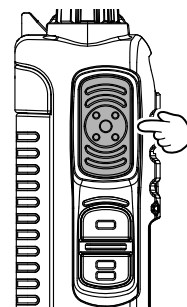

Resetting the Transceiver

To clear all memories and other settings to factory defaults:

1. Turn the transceiver OFF.
2. Press and hold the [CLR] key and [ENT] key while turning the transceiver ON.
3. When the LCD backlight comes on, release the [CLR] key and [ENT] key, to reset all settings to their factory defaults.

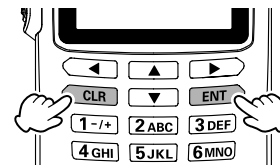

BASIC OPERATION

Operation Modes

The **FTA-250L** operate in the modes listed below. You can switch the modes via the **MENU** screen displayed by pressing the [MENU] key on the front panel.

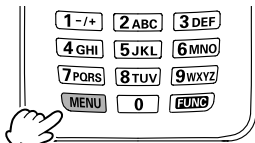

When turning on the **FTA-250L**, the last mode you have used before turning off will automatically be entered.



COMM

The basic operating mode for communication.



MEMORY

This mode provides you with the ability to store and recall as many as 250 channels in the transceiver's main memory bank.



WX CH (WEATHER) *(USA/Canada Only)*

This mode allows you to receive NOAA weather channel broadcasts. The 10 weather channels are pre-programmed at the factory.



SETUP

This mode allows certain aspects of your radio's configuration to be customized for your personal operating conditions.

BASIC OPERATION

BASIC OPERATION OF THE MENU MODE

Using the menu mode, the various functions of the **FTA-250L** can be customized to match the method of use. You can select the items that you would like to adjust from the respective lists and enter or select the appropriate settings for the intended various operation.

1. Press the **[MENU]** key.

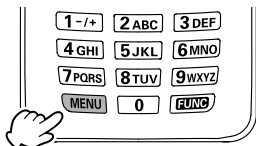

2. Select “**SETUP**” by pressing the **[◀]** or **[▶]** key.



3. Press the **[ENT]** key.

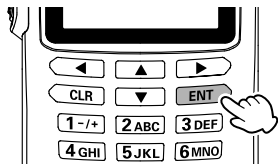

4. Select the desired menu item by pressing the **[▲]** or **[▼]** key, and then press the **[ENT]** key.



5. Select the desired item by pressing the **[▲]** or **[▼]** key, and then press the **[ENT]** key.



6. Select the desired setting by pressing the **[◀]** or **[▶]** key.



7. Press the **[ENT]** key to store the selected setting.
8. Press the PTT switch to return to normal operation.

The same operation process as the above is written as follows in this operation manual.

[MENU] → “**SETUP**” → “**CONFIG**” → “**KEY BEEP**”

ADVANCED OPERATION

Reception of Weather Channel Broadcasts

- Weather Channels for USA/ Canada only -

The **FTA-250L** can receive VHF weather channel broadcasts, which may assist your flight planning. The **FTA-250L** includes a special bank capable of storing 10 weather channels, which simplifies access when you are in an unfamiliar location.

1. Press the **[MENU]** key.
2. Select "**WX CH**" by pressing the **[◀]** or **[▶]** key, and then press the **[ENT]** key.
The last channel you have tuned will be received.
3. You can also select a weather channel from the pre-programmed list with the **[▲]** or **[▼]** key.
4. To exit the WX mode, press the **[MENU]** key, select the mode other than "**WX CH**" by pressing the **[◀]** or **[▶]** key, and then press the **[ENT]** key.

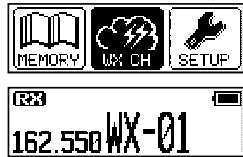

Weather alert reception

In the event of extreme weather disturbances, such as storms and hurricanes, the NOAA (National Oceanic and Atmospheric Administration) sends a weather alert accompanied by a 1050 Hz tone and subsequent weather report on one of the NOAA weather channels.

When the transceiver receives the weather alert on the operating frequency, it displays a warning as below on the screen and continues to make alarm sounds until either of the keys is pressed.

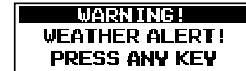

You may enable or disable the alarm function when receiving the weather alert signal via the **COMM SETUP** menu. See page 35 for details.

ADVANCED OPERATION

Dual Watch Operation

The dual watch feature automatically checks for activity on the P-ch (priority channel) set via the **PRIORITY-CH** menu while you are operating on another channel. During the dual watch operation, the current channel and the P-ch will be polled alternately for a 200 ms interval.

Setting the P-ch

1. [MENU] \Rightarrow "SETUP" \Rightarrow "PRIORITY CH".
2. Enter the frequency you want to poll, with the keypad.
3. Select "FINISH" by pressing the [◀] or [▶] key, and then press the [ENT] key.

4. Press the PTT switch to return to normal operation.

Starting the dual watch

1. Press the [FUNC] key.
2. Select "DUAL WATCH" by pressing the [◀] or [▶] key, and then press the [ENT] key.



- The display will return to the previous screen and the "DW" icon will be displayed, indicating the FTA-250L is in dual watch.



- When the transceiver encounters a signal on the current channel, the radio polls both channels alternately with longer staying time on the current channel.
 - When the transceiver encounters a signal in the P-ch, the transceiver stays on the P-ch until the signal disappears, and the frequency indication on the display blinks.
After the signal disappears, the dual watch resumes.
3. To stop the dual watch, repeat steps 1 and 2 above.

ADVANCED OPERATION

Noise Cancellation

To cancel background noise when transmitting and receiving.

Enables/disables the Noise-canceling function of the transmitter and receiver independently.

1. [MENU] → "SETUP" → "COMM SETUP" → "NOISE CANCEL".
2. Select "TX MODE" by pressing the [◀] or [▶] key, and then press the [ENT] key.

3. Press the [◀] or [▶] key to select "ON" or "OFF", and then press the [ENT] key.
4. Select "RX MODE" by pressing the [◀] or [▶] key, and then press the [ENT] key.
5. Select the noise level from "LV 1" through "MAX" or "OFF" by pressing the [◀] or [▶] key, and then press the [ENT] key.
6. Press the PTT switch to return to normal operation.

TOT Feature

The TOT (time-out timer) shuts off the transceiver after continuous transmission exceeds the programmed time. This feature prevents unintended transmission by mistake and reduces battery consumption.

1. [MENU] → "SETUP" → "COMM SETUP" → "TX TOT".
2. Select the desired TOT time by pressing the [◀] or [▶] key, and then press the [ENT] key.

The setting changes in the following order.

1 ↔ 2 ↔ 3 ↔ 4 ↔ 5 (MIN)

Tip: The default setting: 5 MIN

3. Press the PTT switch to return to normal operation.

ADVANCED OPERATION

Battery Saver during Reception

One of the important features of the **FTA-250L** is its battery saver, which “puts the transceiver to sleep” for a time interval, periodically “waking it up” to check for activity. If somebody is talking on the channel, the **FTA-250L** will remain in the “awake” mode, then resume its “sleep” cycles. This feature significantly reduces battery drain.

1. **[MENU]** \Rightarrow **“SETUP”** \Rightarrow **“CONFIG”** \Rightarrow **“BATTERY SAVE”**.

2. Select the desired interval time by pressing the [**◀**] or [**▶**] key, and then press the [**ENT**] key.

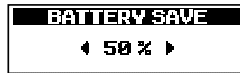

- OFF** : Disables this function.
- 50 %** : Sleeps for 100 ms after 100 ms awake
- 70 %** : Sleeps for 250 ms after 100 ms awake
- 80 %** : Sleeps for 450 ms after 100 ms awake
- 90 %** : Sleeps for 900 ms after 100 ms awake

Tip: The default setting: 50 %

3. Press the **PTT** switch to return to normal operation.

Using the Headset Microphone

If you want to use the microphone of an aviation headset, change the assignment of microphone controlled with the **PTT** switch.

1. **[MENU]** \Rightarrow **“SETUP”** \Rightarrow **“COMM SETUP”** \Rightarrow **“MIC SELECT”**.
2. Select **“EXTERNAL”** by pressing the [**◀**] or [**▶**] key, and then press the [**ENT**] key.



3. Press the **PTT** switch to return to normal operation.

When an optional aviation headset is connected, the **PTT** switch on the transceiver will activate the headset microphone for transmission.

Note: If you find it difficult to use the **PTT** switch of the transceiver, we recommend to use an after-market external **PTT** switch.

ADVANCED OPERATION

VOX Operation

If you want to have both hands free, use a headset and activate the VOX (voice-actuated transmit/receive switching) system.

- Notes:** The VOX system does not work when using just the internal microphone; an external headset must be used.
- Do not activate the VOX system when connecting the optional microphone **SSM-10A**.

1. [MENU] \Rightarrow "SETUP" \Rightarrow "COMM SETUP" \Rightarrow "VOX".

2. Select "ON" or "OFF" by pressing the [◀] or [▶] key, and then press the [ENT] key.



3. Press the **PTT** switch to return to normal operation.

- The "V" icon, which indicates that the VOX system is active.



- To adjust the VOX gain, select one of the following gain levels on the item "VOX LEVEL" of the **COMM SETUP** menu in the SETUP mode.

MIN / LV1 / LV2 / LV3 / MAX

- To set the VOX delay, select one of the following times on the item "VOX DELAY" of the **COMM SETUP** menu in the SETUP mode.

0.5 / 1.0 / 1.5 / 2.0 / 3.0 (SEC)

ADVANCED OPERATION

Side Tone Control

When utilizing an external headset, you may monitor your own voice when talking into the microphone through the headphones.

Note: Do not activate the side tone function when connecting the optional microphone **SSM-10A**.

1. **[MENU]** \Rightarrow **"SETUP"** \Rightarrow **"COMM SETUP"** \Rightarrow **"SIDE TONE"**.
2. Select the side tone level by pressing the **[◀]** or **[▶]** key, and then press the **[ENT]** key.



The setting changes in the following order.

OFF / LV 1 / LV 2 / LV 3 / MAX

3. Press the **PTT** switch to return to normal operation.
- To change the side tone level temporarily during the monitoring, pressing the **[▲]**, **[▼]**, **[◀]** or **[▶]** key when pressing and holding the **PTT** switch.

Lock Function

This function prevents accidental changes to the frequency setting and the keypad controls.

1. Press and hold the **LOCK** key.
 - While the **FTA-250L** is locked, the controls with the keys except the **PTT** switch, **SQL** key, **LOCK** key, the **PWR/VOL** knob, and the **[121.5]** key are disabled.
 - If any of the keys is pressed, either of **"KEY LOCK"** will appear on the screen for 2 seconds and then the display will return to the previous screen.

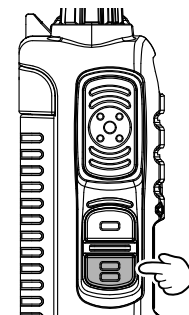

KEY LOCK

2. To turn the lock feature off, press and hold the **LOCK** key again. **"UNLOCK"** will appear on the screen for 2 seconds and then the display will return to the previous screen.

ADVANCED OPERATION

PTT Lock Function

This function prevents accidental transmissions by locking or disabling the PTT switch.

Turning lock/unlock the PTT lock function

You may enable or disable the PTT lock function.

1. [MENU] → "SETUP" → "CONFIG" → "PTT LOCK".
2. Select "ON" or "OFF" by pressing the [▲] or [▼] key, and then press the [ENT] key.
3. Press the PTT switch to return to normal operation.



ANL Feature

For reduction of impulse noise, such as that produced by an engine's ignition system, the ANL (automatic noise limiter) feature may prove helpful.

1. [MENU] → "SETUP" → "COMM SETUP" → "ANL".
 2. Select "ON" or "OFF" by pressing the [▲] or [▼] key, and then press the [ENT] key.
 3. Press the PTT switch to return to normal operation.
- The "ANL" icon, which indicates that the ANL system is active.



ADVANCED OPERATION

Changing the Channel Steps

The synthesizer of the **FTA-250L** provides the option of utilizing 8.33*/25 kHz channel steps.

* 8.33 kHz; Europe only

1. **[MENU]** **▶▶** **"SETUP"** **▶▶** **"COMM SETUP"** **▶▶** **"FREQ STEP"**.
2. Select **"25 KHZ"** or **"8.33KHZ"** by pressing the **[▲]** or **[▼]** key, and then press the **[ENT]** key.

FREQ STEP
 ◀ 8.33 KHZ ▶
3. Press the **PTT** switch to return to normal operation.

Note: When you set the channel step to 8.33 kHz, the channel display differs from actual operating frequency; see the chart below. However, the operator (pilot, tower, control, etc.) will call out the frequency according to what the display indicates.

Operating Frequency	Display	
	8.33 kHz Step	25 kHz Step
1**.0000 MHz	1**.005	1**.000
1**.0083 MHz	1**.010	
1**.0166 MHz	1**.015	
1**.0250 MHz	1**.030	1**.025
1**.0333 MHz	1**.035	
1**.0416 MHz	1**.040	
1**.0500 MHz	1**.055	1**.050
1**.0583 MHz	1**.060	
1**.0666 MHz	1**.065	
1**.0750 MHz	1**.080	1**.075
1**.0833 MHz	1**.085	
1**.0916 MHz	1**.090	

- The adjacent channel selectivity will be slightly degraded while receiving using 8.33 kHz channel steps.