



YAMAHA

132pgs Motorcycle

OWNER'S MANUAL

Vmax

**VMX12N
VMX12NC**

5GK-28199-11

LIT-11626-14-12

EAU03438

⚠ WARNING

The engine exhaust from this product contains chemicals known to the State of California to cause cancer, birth defects or other reproductive harm.

YAMAHA

LIT-CALIF-65-01

Congratulations on your purchase of the Yamaha VMX12/VMX12C. This model is the result of Yamaha's vast experience in the production of fine sporting, touring, and pacesetting racing machines. It represents the high degree of craftsmanship and reliability that have made Yamaha a leader in these fields.

This manual will give you an understanding of the operation, inspection, and basic maintenance of this motorcycle. If you have any questions concerning the operation or maintenance of your motorcycle, please consult a Yamaha dealer.

The design and manufacture of this Yamaha motorcycle fully comply with the emissions standards for clean air applicable at the date of manufacture. Yamaha has met these standards without reducing the performance or economy of operation of the motorcycle. To maintain these high standards, it is important that you and your Yamaha dealer pay close attention to the recommended maintenance schedules and operating instructions contained within this manual.

IMPORTANT MANUAL INFORMATION

EAU00003

Particularly important information is distinguished in this manual by the following notations:



The Safety Alert Symbol means **ATTENTION! BECOME ALERT! YOUR SAFETY IS INVOLVED!**



Failure to follow **WARNING** instructions could result in severe injury or death to the motorcycle operator, a bystander or a person inspecting or repairing the motorcycle.



A **CAUTION** indicates special precautions that must be taken to avoid damage to the motorcycle.

NOTE:

A **NOTE** provides key information to make procedures easier or clearer.

NOTE:

- This manual should be considered a permanent part of this motorcycle and should remain with it even if the motorcycle is subsequently sold.
 - Yamaha continually seeks advancements in product design and quality. Therefore, while this manual contains the most current product information available at the time of printing, there may be minor discrepancies between your motorcycle and this manual. If you have any questions concerning this manual, please consult your Yamaha dealer.
-

IMPORTANT MANUAL INFORMATION

EW000000

WARNING

PLEASE READ THIS MANUAL AND THE “YOU AND YOUR MOTORCYCLE: RIDING TIPS” BOOKLET CAREFULLY AND COMPLETELY BEFORE OPERATING THIS MOTORCYCLE. DO NOT ATTEMPT TO OPERATE THIS MOTORCYCLE UNTIL YOU HAVE ATTAINED ADEQUATE KNOWLEDGE OF ITS CONTROLS AND OPERATING FEATURES AND UNTIL YOU HAVE BEEN TRAINED IN SAFE AND PROPER RIDING TECHNIQUES. REGULAR INSPECTIONS AND CAREFUL MAINTENANCE, ALONG WITH GOOD RIDING SKILLS, WILL ENSURE THAT YOU SAFELY ENJOY THE CAPABILITIES AND THE RELIABILITY OF THIS MOTORCYCLE.

IMPORTANT MANUAL INFORMATION

AFFIX DEALER

LABEL HERE

EAU03336

**VMX12N/VMX12NC
OWNER'S MANUAL**

© 2000 by Yamaha Motor Corporation, U.S.A.

1st Edition, April 2000

All rights reserved.

**Any reprinting or unauthorized use
without the written permission of
Yamaha Motor Corporation, U.S.A.
is expressly prohibited.**

Printed in Japan.

P/N LIT-11626-14-12

1 SAFETY INFORMATION

2 DESCRIPTION

3 INSTRUMENT AND CONTROL FUNCTIONS

4 PRE-OPERATION CHECKS

5 OPERATION AND IMPORTANT RIDING POINTS

6 PERIODIC MAINTENANCE AND MINOR REPAIR

7 MOTORCYCLE CARE AND STORAGE

8 SPECIFICATIONS

9 CONSUMER INFORMATION

INDEX



SAFETY INFORMATION

Safe riding	1-1
Protective apparel	1-3
Modifications	1-3
Loading and accessories	1-3
Gasoline and exhaust gas.....	1-5
Location of important labels	1-7

MOTORCYCLES ARE SINGLE TRACK VEHICLES. THEIR SAFE USE AND OPERATION ARE DEPENDENT UPON THE USE OF PROPER RIDING TECHNIQUES AS WELL AS THE EXPERTISE OF THE OPERATOR. EVERY OPERATOR SHOULD KNOW THE FOLLOWING REQUIREMENTS BEFORE RIDING THIS MOTORCYCLE.

HE OR SHE SHOULD:

1. OBTAIN THOROUGH INSTRUCTIONS FROM A COMPETENT SOURCE ON ALL ASPECTS OF MOTORCYCLE OPERATION.
2. OBSERVE THE WARNINGS AND MAINTENANCE REQUIREMENTS IN THE OWNER'S MANUAL.
3. OBTAIN QUALIFIED TRAINING IN SAFE AND PROPER RIDING TECHNIQUES.
4. OBTAIN PROFESSIONAL TECHNICAL SERVICE AS INDICATED BY THE OWNER'S MANUAL AND/OR WHEN MADE NECESSARY BY MECHANICAL CONDITIONS.

Safe riding

1. Always make pre-operation checks. Careful checks may help prevent an accident.
2. This motorcycle is designed to carry the operator and a passenger.
3. The failure of motorists to detect and recognize motorcycles in traffic is the predominating cause of automobile/motorcycle accidents. Many accidents have been caused by an automobile driver who did not see the motorcycle. Making yourself conspicuous appears to be very effective in reducing the chance of this type of accident.

Therefore:

- a. Wear a brightly colored jacket.
- b. Use extra caution when you are approaching and passing through intersections, since intersections are the most likely places for motorcycle accidents to occur.
- c. Ride where other motorists can see you. Avoid riding in another motorist's blind spot.

4. Many accidents involve inexperienced operators. In fact, many operators who have been involved in accidents do not even have a current motorcycle license.
 - a. Make sure that you are qualified and that you only lend your motorcycle to other qualified operators.
 - b. Know your skills and limits. Staying within your limits may help you to avoid an accident.
 - c. We recommend that you practice riding your motorcycle where there is no traffic until you have become thoroughly familiar with the motorcycle and all of its controls.
5. Many accidents have been caused by error of the motorcycle operator. A typical error made by the operator is veering wide on a turn due to **EXCESSIVE SPEED** or undercornering (insufficient lean angle for the speed).
 - a. Always obey the speed limit and never travel faster than warranted by road and traffic conditions.
 - b. Always signal before turning or changing lanes. Make sure that other motorists can see you.
6. The posture of the operator and passenger is important for proper control.
 - a. The operator should keep both hands on the handlebar and both feet on the operator footrests during operation to maintain control of the motorcycle.
 - b. The passenger should always hold onto the operator, the seat strap or grab bar, if equipped, with both hands and keep both feet on the passenger footrests.
 - c. Never carry a passenger unless he or she can firmly place both feet on the passenger footrests.
7. Never ride under the influence of alcohol or other drugs.
8. This motorcycle is designed for on-road use only. It is not suitable for off-road use.

SAFETY INFORMATION

Protective apparel

The majority of fatalities from motorcycle accidents are the result of head injuries. The use of a safety helmet is the single most critical factor in the prevention or reduction of head injuries.

1. Always wear an approved helmet.
2. Wear a face shield or goggles. Wind in your unprotected eyes could contribute to an impairment of vision that could delay seeing a hazard.
3. The use of a jacket, heavy boots, trousers, gloves, etc., is effective in preventing or reducing abrasions or lacerations.
4. Never wear loose-fitting clothes, otherwise they could catch on the control levers, footrests, or wheels and cause injury or an accident.
5. Never touch the engine or exhaust system during or after operation. They become very hot and can cause burns. Always wear protective clothing that covers your legs, ankles, and feet.
6. A passenger should also observe the above precautions.

Modifications

Modifications made to this motorcycle not approved by Yamaha, or the removal of original equipment, may render the motorcycle unsafe for use and may cause severe personal injury. Modifications may also make your motorcycle illegal to use.

Loading and accessories

Adding accessories or cargo to your motorcycle can adversely affect stability and handling if the weight distribution of the motorcycle is changed. To avoid the possibility of an accident, use extreme caution when adding cargo or accessories to your motorcycle. Use extra care when riding a motorcycle that has added cargo or accessories. Here are some general guidelines to follow if loading cargo or adding accessories to your motorcycle:

Loading

The total weight of the operator, passenger, accessories and cargo must not exceed the maximum load limit of VMX12: 476 lb (216 kg) / VMX12C: 474 lb (215 kg). When loading within this weight limit, keep the following in mind:

1. Cargo and accessory weight should be kept as low and close to the motorcycle as possible. Make sure to distribute the weight as evenly as possible on both sides of the motorcycle to minimize imbalance or instability.
2. Shifting weights can create a sudden imbalance. Make sure that accessories and cargo are securely attached to the motorcycle before riding. Check accessory mounts and cargo restraints frequently.
3. Never attach any large or heavy items to the handlebar, front fork, or front fender. These items, including such items as sleeping bags, duffel bags, or tents, can create unstable handling or a slow steering response.

Accessories

Genuine Yamaha accessories have been specifically designed for use on this motorcycle. Since Yamaha cannot test all other accessories that may be available, you must personally be responsible for the proper selection, installation and use of non-Yamaha accessories. Use extreme caution when selecting and installing any accessories.

Keep the following guidelines in mind, as well as those provided under “Loading” when mounting accessories.

1. Never install accessories or carry cargo that would impair the performance of your motorcycle. Carefully inspect the accessory before using it to make sure that it does not in any way reduce ground clearance or cornering clearance, limit suspension travel, steering travel or control operation, or obscure lights or reflectors.

SAFETY INFORMATION

- a. Accessories fitted to the handlebar or the front fork area can create instability due to improper weight distribution or aerodynamic changes. If accessories are added to the handlebar or front fork area, they must be as lightweight as possible and should be kept to a minimum.
 - b. Bulky or large accessories may seriously affect the stability of the motorcycle due to aerodynamic effects. Wind may attempt to lift the motorcycle, or the motorcycle may become unstable in cross winds. These accessories may also cause instability when passing or being passed by large vehicles.
 - c. Certain accessories can displace the operator from his or her normal riding position. This improper position limits the freedom of movement of the operator and may limit control ability, therefore, such accessories are not recommended.
2. Use caution when adding electrical accessories. If electrical accessories exceed the capacity of the motorcycle's electrical system, an electric failure could result, which could cause a dangerous loss of lights or engine power.

Gasoline and exhaust gas

1. **GASOLINE IS HIGHLY FLAMMABLE:**
 - a. Always turn the engine off when refueling.
 - b. Take care not to spill any gasoline on the engine or exhaust system when refueling.
 - c. Never refuel while smoking or in the vicinity of an open flame.
2. Never start the engine or let it run for any length of time in a closed area. The exhaust fumes are poisonous and may cause loss of consciousness and death within a short time. Always operate your motorcycle in an area that has adequate ventilation.
3. Always turn the engine off before leaving the motorcycle unattended and remove the key from the main switch. When parking the motorcycle, note the following:



SAFETY INFORMATION

- a. The engine and exhaust system may be hot, therefore, park the motorcycle in a place where pedestrians or children are not likely to touch these hot areas.
 - b. Do not park the motorcycle on a slope or soft ground, otherwise it may fall over.
 - c. Do not park the motorcycle near a flammable source (e.g., a kerosene heater, or near an open flame), otherwise it could catch fire.
4. When transporting the motorcycle in another vehicle, make sure that it is kept upright. If the motorcycle should lean over, gasoline may leak out of the carburetor or fuel tank.
 5. If you should swallow any gasoline, inhale a lot of gasoline vapor, or allow gasoline to get into your eyes, see your doctor immediately. If any gasoline spills on your skin or clothing, immediately wash the affected area with soap and water and change your clothes.

SAFETY INFORMATION

EAU02977

Location of important labels

Please read the following important labels carefully before operating this motorcycle.

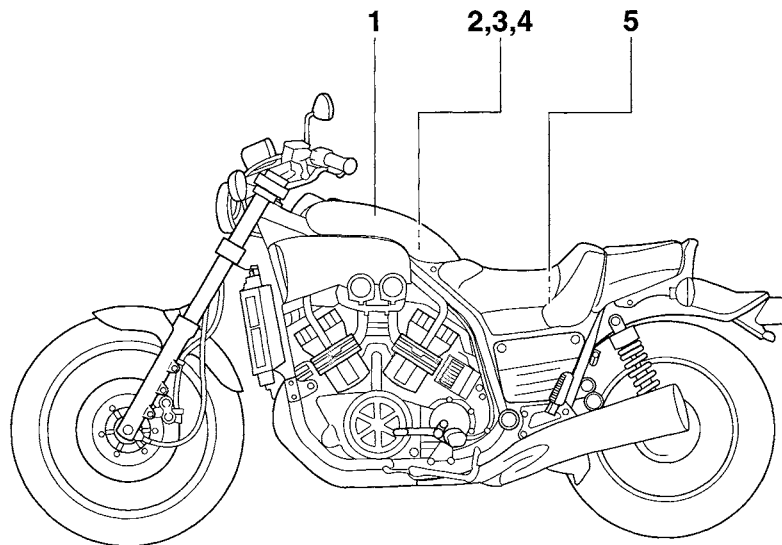

1

! WARNING

- **BEFORE YOU OPERATE THIS VEHICLE, READ THE OWNER'S MANUAL AND ALL LABELS.**
- **ALWAYS WEAR AN APPROVED MOTORCYCLE HELMET, eye protection, and protective clothing.**

3MX-2118K-A0

2

CAUTION

- Read owner's manual before servicing battery.
- Electrolyte will damage metal parts or paint. If electrolyte spills, wash area with fresh water immediately.
- Be sure to connect breather hose after installing battery.

3JL-28177-A0

3

TIRE INFORMATION

Cold tire normal pressure should be set as follows.

- Up to 90 kg (198 lbs) load

FRONT : 225 kPa, {2.25 kgf/cm²}, 33 psi

REAR : 225 kPa, {2.25 kgf/cm²}, 33 psi- 90 kg (198 lbs) ~ maximum load

FRONT : 225 kPa, {2.25 kgf/cm²}, 33 psi

REAR : 250 kPa, {2.50 kgf/cm²}, 36 psi

5BN-21668-00

4

California only

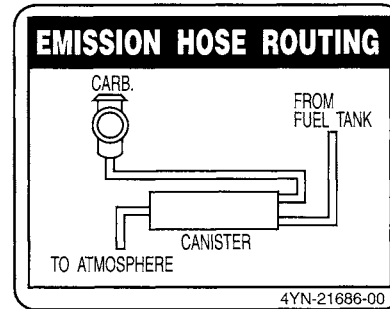

5

! WARNING

PASS LEAD WIRES THROUGH HOLE, as shown. A short circuit could result from improper routing. This could cause the engine to stop running and lights to fail, which could result in an accident.

HOLE

3JP-2415H-A0

1

DESCRIPTION

Left view	2-1
Right view.....	2-2
Controls and instruments	2-3

Left view

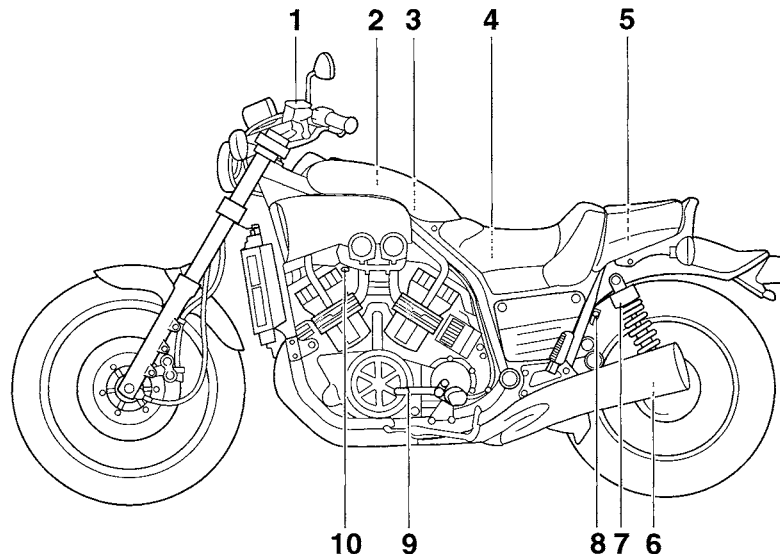

- | | | | |
|---|-------------|--|-------------|
| 1. Clutch master cylinder reservoir | (page 6-29) | 7. Rear shock absorber damping force
adjusting knob | (page 3-13) |
| 2. Air filter element | (page 6-21) | 8. Helmet holder | (page 3-10) |
| 3. Fuse box | (page 6-38) | 9. Shift pedal | (page 3-5) |
| 4. Main fuse box | (page 6-38) | 10. Starter (choke) lever | (page 3-8) |
| 5. Owner's tool kit | (page 6-1) | | |
| 6. Rear shock absorber spring preload
adjusting ring | (page 3-13) | | |

Right view

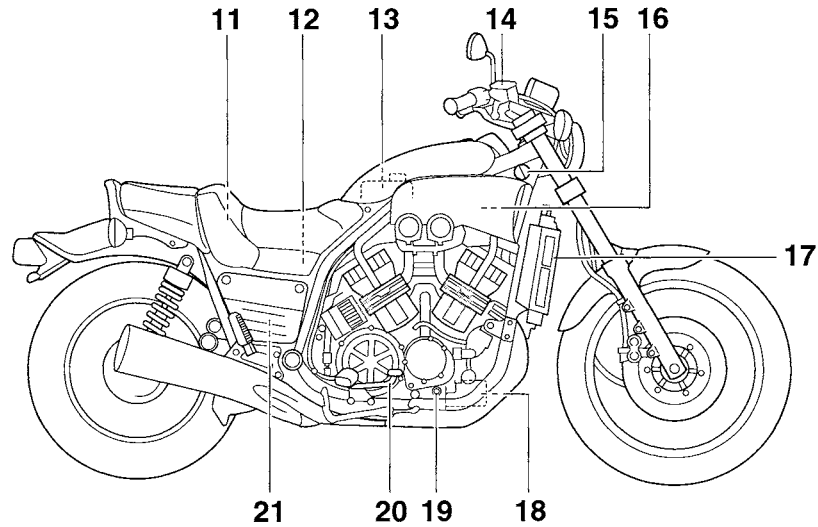

- | | |
|---|-------------|
| 11. Fuel tank cap | (page 3-6) |
| 12. Battery | (page 6-35) |
| 13. Coolant reservoir | (page 6-16) |
| 14. Front brake master cylinder reservoir | (page 6-29) |
| 15. Main switch | (page 3-1) |
| 16. Radiator cap | (page 6-18) |
| 17. Radiator | (page 6-18) |
| 18. Engine oil filter cartridge | (page 6-12) |
| 19. Engine oil level check window | (page 6-11) |
| 20. Brake pedal | (page 3-6) |
| 21. Rear brake fluid reservoir | (page 6-29) |

DESCRIPTION

Controls and instruments

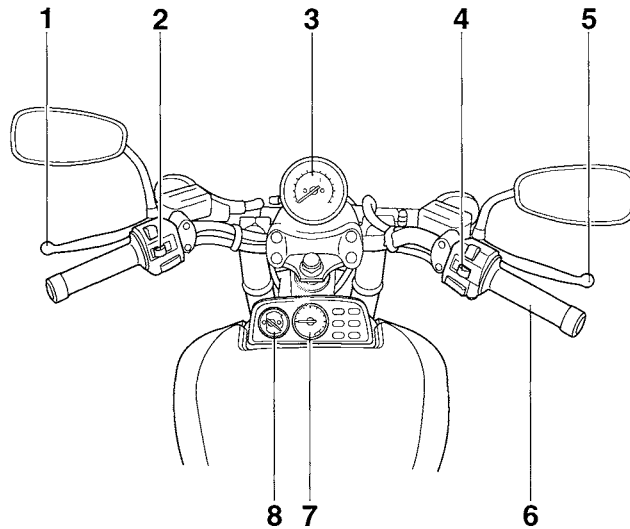

- 1. Clutch lever
- 2. Left handlebar switches
- 3. Speedometer unit
- 4. Right handlebar switches
- 5. Brake lever
- 6. Throttle grip
- 7. Tachometer
- 8. Coolant temperature gauge

- (page 3-5)
- (page 3-3)
- (page 3-2)
- (page 3-4)
- (page 3-5)
- (page 6-22)
- (page 3-3)
- (page 3-3)

INSTRUMENT AND CONTROL FUNCTIONS

Main switch	3-1
Indicator and warning lights	3-1
Speedometer unit	3-2
Tachometer	3-3
Coolant temperature gauge	3-3
Handlebar switches	3-3
Clutch lever	3-5
Shift pedal	3-5
Brake lever	3-5
Brake pedal	3-6
Fuel tank cap	3-6
Fuel	3-7
Starter (choke) lever	3-8
Steering lock	3-9
Rider seat	3-9
Helmet holder	3-10
Adjusting the front fork	3-11
Adjusting the shock absorber assemblies	3-12
Matching the front and rear suspension settings	3-15
V-Boost	3-16
Sidestand	3-17
Ignition circuit cut-off system	3-17

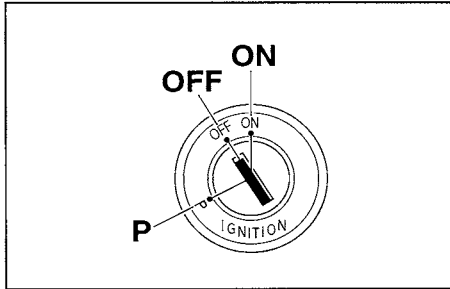

EAU00028

Main switch

The main switch controls the ignition and lighting systems. The various main switch positions are described below.

EAU00032

ON

All electrical systems are supplied with power, the headlight, meter lighting, taillight and front position lights come on, and the engine can be started. The key cannot be removed.

EAU00038

OFF

All electrical systems are off. The key can be removed.

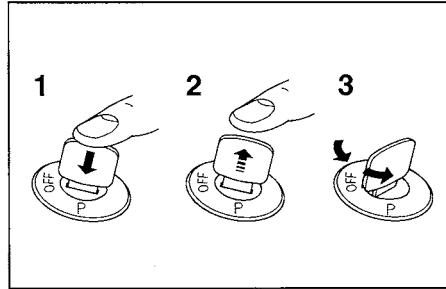

1. Push.
2. Release.
3. Turn.

EAU00051

P (Parking)

The meter light, taillight and position lights are on, but all other electrical systems are off. The key can be removed. The key must be pushed in from the "OFF" position to be turned to "P".

ECA00043

CAUTION:

Do not use the parking position for an extended length of time, otherwise the battery may discharge.

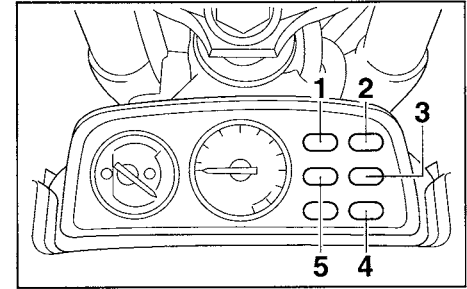

1. Neutral indicator light "NEUTRAL"
2. Turn signal indicator light "TURN"
3. Fuel level warning light "FUEL"
4. High beam indicator light "HIGH BEAM"
5. Oil level warning light "OIL LEVEL"

EAU03034

Indicator and warning lights

EAU00062

Neutral indicator light "NEUTRAL"

This indicator light comes on when the transmission is in the neutral position.

EAU00059

Turn signal indicator light "TURN"

This indicator light flashes when the turn signal switch is pushed to the left or right.

INSTRUMENT AND CONTROL FUNCTIONS

Fuel level warning light “FUEL”

EAU03365

This warning light comes on when the fuel level drops below approximately 3 L (0.7 Imp gal, 0.8 US gal). When this occurs, refuel as soon as possible.

The electrical circuit of the warning light can be checked according to the following procedure.

1. Turn the key to “ON”.
2. If the warning light does not come on, have a Yamaha dealer check the electrical circuit.

High beam indicator light “HIGH BEAM”

EAU00064

This indicator light comes on when the high beam of the headlight is switched on.

Oil level warning light “OIL LEVEL”

EAU03366

This warning light comes on when the engine oil level is low.

The electrical circuit of the warning light can be checked according to the following procedure.

1. Turn the key to “ON”.
2. If the warning light does not come on, have a Yamaha dealer check the electrical circuit.

NOTE: _____

Even if the oil level is sufficient, the warning light may flicker when riding on a slope or during sudden acceleration or deceleration, but this is not a malfunction.

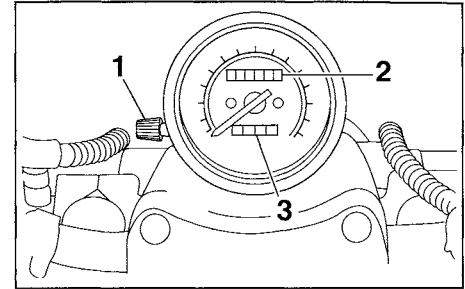

1. Tripmeter reset knob
2. Odometer
3. Tripmeter

Speedometer unit

EAU00095

The speedometer unit is equipped with a speedometer, an odometer and a tripmeter. The speedometer shows riding speed. The odometer shows the total distance traveled. The tripmeter shows the distance traveled since it was last set to zero with the reset knob. The tripmeter can be used to estimate the distance that can be traveled with a full tank of fuel. This information will enable you to plan future fuel stops.

INSTRUMENT AND CONTROL FUNCTIONS

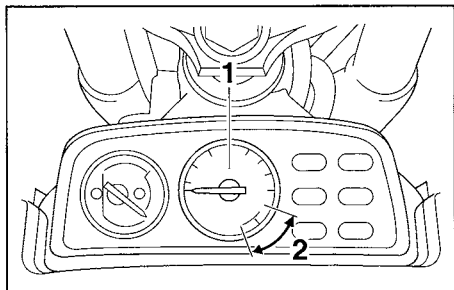

1. Tachometer
2. Red zone

EAU00101

Tachometer

The electric tachometer allows the rider to monitor the engine speed and keep it within the ideal power range.

EC000003

CAUTION:

Do not operate the engine in the tachometer red zone.

Red zone: 8,500 r/min and above

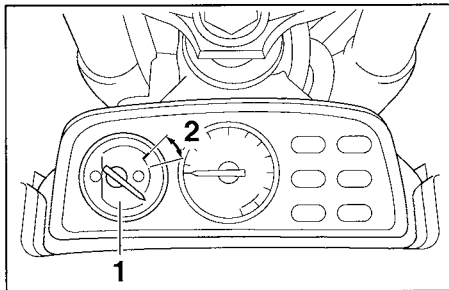

1. Coolant temperature gauge
2. Red zone

EAU01652

Coolant temperature gauge

With the key in the “ON” position, the coolant temperature gauge indicates the temperature of the coolant. The coolant temperature varies with changes in the weather and engine load. If the needle reaches or enters the red zone, stop the motorcycle and let the engine cool. (See page 6-47 for further instructions.)

EC000002

CAUTION:

Do not operate the engine if it is overheated.

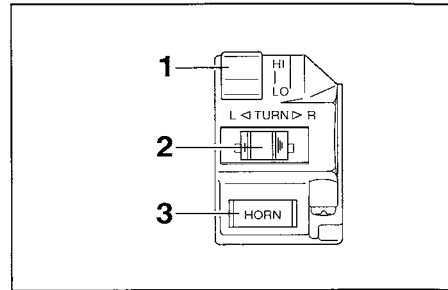

1. Dimmer switch “LIGHTS”
2. Turn signal switch “TURN”
3. Horn switch “HORN”

EAU00118

Handlebar switches

EAU00122

Dimmer switch “LIGHTS”

Set the switch to “HI” for the high beam and to “LO” for the low beam.

EAU01189

Turn signal switch “TURN”

To signal a right-hand turn, push this switch to the right. To signal a left-hand turn, push the switch to the left. When released, the switch returns to the center position.

INSTRUMENT AND CONTROL FUNCTIONS

Since this model is equipped with a self-canceling system, the turn signal lights will self-cancel after the motorcycle has traveled both about 150 m (490 ft) and for approximately 15 seconds. However, the turn signal lights can also be canceled manually by pushing the switch in after it has returned to the center position.

NOTE:

The self-canceling system only operates when the motorcycle is moving, so that the turn signal lights will not self-cancel while you are stopped at an intersection.

EAU00130

Horn switch "HORN"

Press this switch to sound the horn.

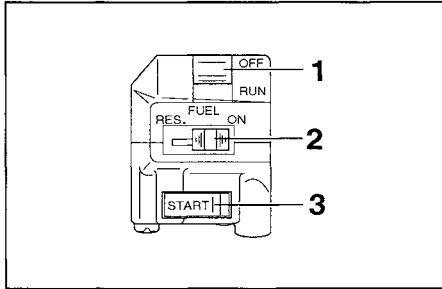

1. Engine stop switch "ENGINE STOP"
2. Fuel reserve switch "FUEL"
3. Start switch "START"

EAU00137

Engine stop switch "ENGINE STOP"

Set this switch to "OFF" to stop the engine in case of an emergency, such as when the motorcycle overturns or when the throttle cable is stuck.

EAU01653

Fuel reserve switch "FUEL"

During normal operation, this switch should be kept in the "ON" position. If the fuel warning light comes on while riding, set the switch to "RES", refuel as soon as possible, and then set the switch back to "ON".

NOTE:

After switching to "RES", approximately 3 L (0.7 Imp gal, 0.8 US gal) of fuel remain in the fuel tank.

EAU00141

Start switch "START"

Push this switch to crank the engine with the starter.

EC000005

CAUTION:

See page 5-1 for starting instructions prior to starting the engine.

INSTRUMENT AND CONTROL FUNCTIONS

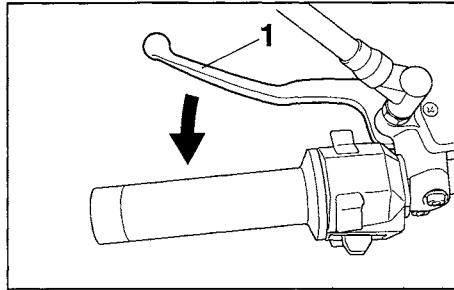

1. Clutch lever

EAU00152

Clutch lever

The clutch lever is located at the left handlebar grip. To disengage the clutch, pull the lever toward the handlebar grip. To engage the clutch, release the lever. The lever should be pulled rapidly and released slowly for smooth clutch operation.

The clutch lever is equipped with a clutch switch, which is part of the ignition circuit cut-off system. (See page 3-17 for an explanation of the ignition circuit cut-off system.)

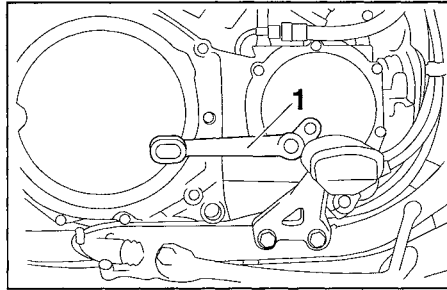

1. Shift pedal

EAU00157

Shift pedal

The shift pedal is located on the left side of the engine and is used in combination with the clutch lever when shifting the gears of the 5-speed constant-mesh transmission equipped on this motorcycle.

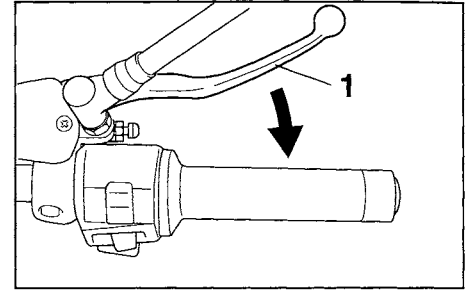

1. Brake lever

EAU00158

Brake lever

The brake lever is located at the right handlebar grip. To apply the front brake, pull the lever toward the handlebar grip.

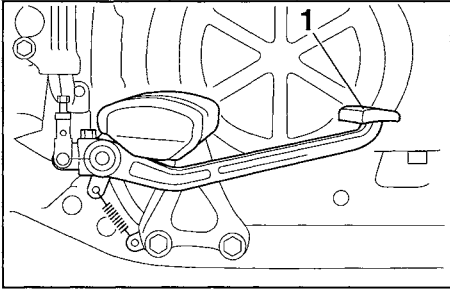

1. Brake pedal

EAU00162

Brake pedal

The brake pedal is on the right side of the motorcycle. To apply the rear brake, press down on the brake pedal.

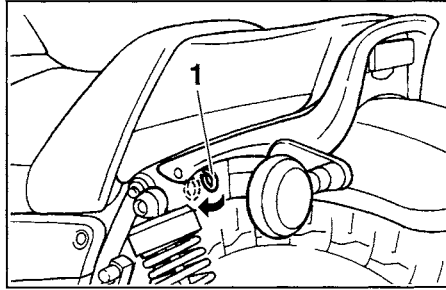

1. Lever (x 2)

EAU01654

Fuel tank cap

To remove the fuel tank cap

1. Push the levers on the left and right side of the rider seat backrest as shown and slide the rider seat backrest forward.

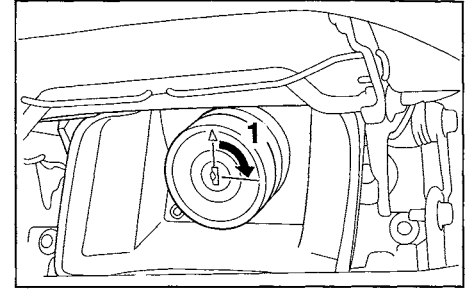

1. Open.

2. Insert the key into the lock, and then turn it 1/4 turn clockwise. The lock will be released and the fuel tank cap can be opened.

INSTRUMENT AND CONTROL FUNCTIONS

To install the fuel tank cap

1. Insert the fuel tank cap into the tank opening with the key inserted in the lock.
2. Turn the key counterclockwise, and then remove it.
3. Slide the rider seat backrest rearward and push it down.

NOTE:
The fuel tank cap cannot be installed unless the key is in the lock. In addition, the key cannot be removed if the cap is not properly installed and locked.

EW000024

WARNING

Make sure that the fuel tank cap is properly installed before riding.

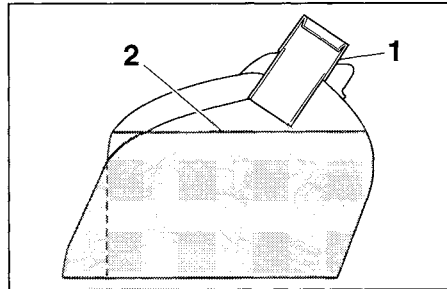

1. Filler tube
2. Fuel level

EAU001183

Fuel

Make sure that there is sufficient fuel in the tank. Fill the fuel tank to the bottom of the filler tube as shown in the illustration.

EW000130

WARNING

- Do not overfill the fuel tank, otherwise it may overflow when the fuel warms up and expands.
- Avoid spilling fuel on the hot engine.

EAU00185

CAUTION:

Immediately wipe off spilled fuel with a clean, dry, soft cloth, since fuel may deteriorate painted surfaces or plastic parts.

EAU00189

Recommended fuel:

UNLEADED FUEL

Fuel tank capacity:

Total amount:

15 L (3.3 Imp gal, 4.0 US gal)

Reserve amount:

3 L (0.7 Imp gal, 0.8 US gal)

Your Yamaha engine has been designed to use regular unleaded gasoline with a pump octane number $[(R+M)/2]$ of 86 or higher, or a research octane number of 91 or higher. If knocking (or pinging) occurs, use a gasoline of a different brand or premium unleaded fuel. Use of unleaded fuel will extend spark plug life and reduce

maintenance costs. If unleaded gasoline is not available, then leaded regular gasoline can be used.

Gasohol

There are two types of gasohol: gasohol containing ethanol and that containing methanol. Gasohol containing ethanol can be used if the ethanol content does not exceed 10%. Gasohol containing methanol is not recommended by Yamaha because it can cause damage to the fuel system or vehicle performance problems.

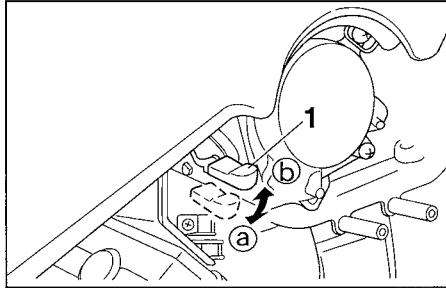

1. Starter (choke) lever

EAU02976

Starter (choke) lever

Starting a cold engine requires a richer air-fuel mixture, which is supplied by the starter (choke).

Move the lever in direction ① to turn on the starter (choke).

Move the lever in direction ② to turn off the starter (choke).

INSTRUMENT AND CONTROL FUNCTIONS

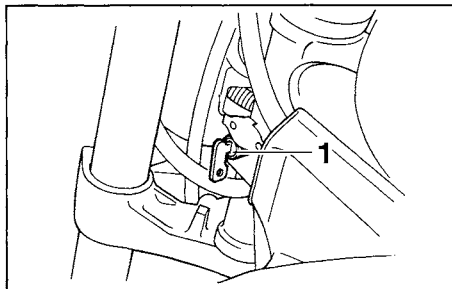

1. Steering lock

EAU03942

Steering lock

To lock the steering

1. Turn the handlebar all the way to the right.
2. Open the steering lock cover, and then insert the steering lock key.
3. Turn the key 1/8 turn counterclockwise, push it in while turning the handlebar slightly to the left, and then turn the key 1/8 turn clockwise.
4. Check that the steering is locked, remove the key, and then close the lock cover.

To unlock the steering

1. Open the steering lock cover, and then insert the steering lock key.
2. Push the key in, turn it 1/8 turn counterclockwise so that it moves out, and then release it.
3. Remove the key, and then close the lock cover.

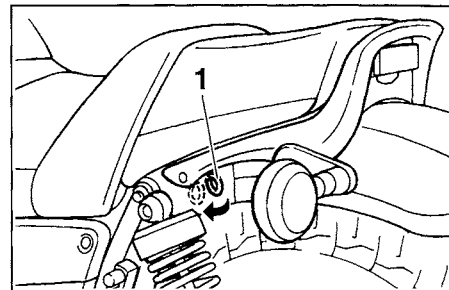

1. Lever (x 2)

EAU03413

Rider seat

To remove the rider seat

1. Release the rider seat backrest by pushing the levers on the left and right side as shown, and then slide the backrest forward.

INSTRUMENT AND CONTROL FUNCTIONS

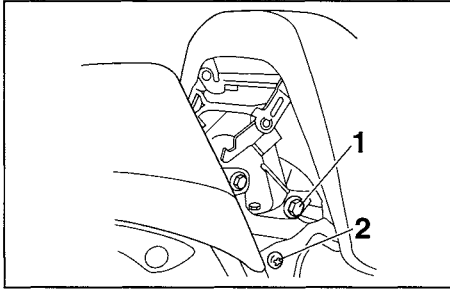

1. Bolt (× 2)
2. Screw (× 2)

2. Remove the bolts and screws, and then pull the rider seat off.

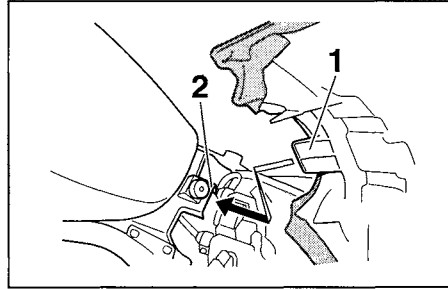

1. Projection
2. Seat holder

To install the rider seat

1. Insert the projection on the front of the rider seat into the seat holder as shown.
2. Place the rider seat in the original position, and then tighten the bolts and screws.

NOTE: _____
Make sure that the seat is properly secured before riding.

3. Return the rider seat backrest to the original position.

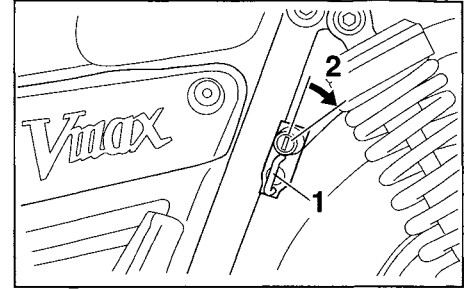

1. Helmet holder
2. Open.

Helmet holder

To open the helmet holder, insert the key into the lock, and then turn the key as shown.

To lock the helmet holder, place it in the original position, and then remove the key.

EAU00260

EW000030



Never ride with a helmet attached to the helmet holder, since the helmet may hit objects, causing loss of control and possibly an accident.

INSTRUMENT AND CONTROL FUNCTIONS

Adjusting the front fork

EAU03414

This front fork is equipped with air valves for adjusting the spring rate.

EW000035

⚠ WARNING

Always adjust both fork legs equally, otherwise poor handling and loss of stability may result.

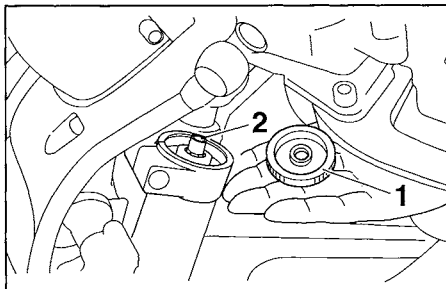

1. Air valve cap
2. Air valve

Adjust the spring rate as follows.

1. Elevate the front wheel by placing the motorcycle on the centerstand.

NOTE: _____
When checking and adjusting the air pressure, there should be no weight on the front end of the motorcycle.

2. Remove the air valve cap from each fork leg.

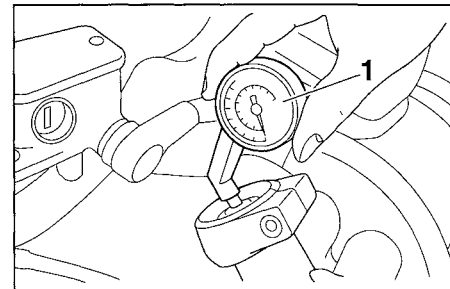

1. Air pressure gauge
3. Check the air pressure in each fork leg with an air pressure gauge.

NOTE: _____
An optional air pressure gauge is available at a Yamaha dealer.

4. To increase the spring rate and thereby harden the suspension, increase the air pressure with an air pump or compressed air. To decrease the spring rate and thereby soften the suspension, decrease the air pressure by pushing each valve stem down.

Spring rate:

Minimum/standard (soft):

Air pressure =
40 kPa (0.4 kgf/cm², 5.7 psi)

Maximum (hard):

Air pressure =
100 kPa (1.0 kgf/cm², 14 psi)

EC000012

CAUTION:

Never exceed the maximum air pressure, otherwise the front fork oil seals may become damaged.

EWA00037

WARNING

There must be no difference in air pressure between the left and right fork legs, otherwise poor handling and loss of stability may result.

5. Securely install the air valve caps.

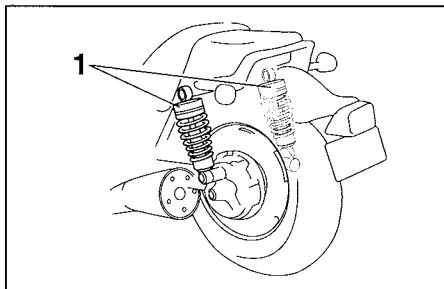

1. Shock absorber assembly (x 2)

EAU01657

Adjusting the shock absorber assemblies

Both shock absorber assemblies are equipped with a spring preload adjusting ring and a damping force adjusting knob.

EC000015

CAUTION:

Never attempt to turn an adjusting mechanism beyond the maximum or minimum settings.

WARNING

Always adjust both shock absorber assemblies equally, otherwise poor handling and loss of stability may result.

INSTRUMENT AND CONTROL FUNCTIONS

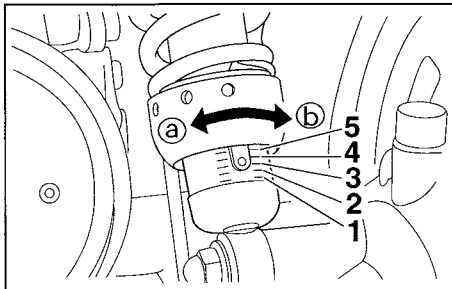

NOTE:

- Align the bottom edge of the adjusting ring with the appropriate setting on the shock absorber.
- Use the special wrench included in the owner's tool kit to make this adjustment.

Spring preload:

Minimum (soft): 1

Standard: 1

Maximum (hard): 5

Spring preload

To increase the spring preload and thereby harden the suspension, turn the adjusting ring on each shock absorber assembly in direction (a). To decrease the spring preload and thereby soften the suspension, turn the adjusting ring on each shock absorber assembly in direction (b).

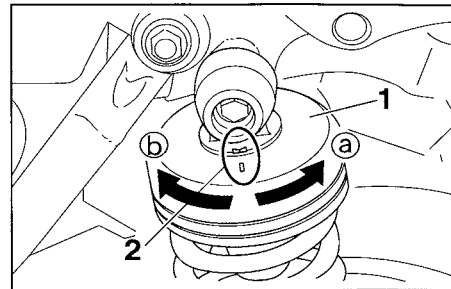

1. Damping force adjusting knob

2. Position indicator

Damping force

To increase the damping force and thereby harden the damping, turn the adjusting knob on each shock absorber assembly in direction (a). To decrease the damping force and thereby soften the damping, turn the adjusting knob on each shock absorber assembly in direction (b).

NOTE:

Align the appropriate setting on the adjusting knob with the position indicator on the shock absorber.

INSTRUMENT AND CONTROL FUNCTIONS

Damping force:

Minimum (soft): 1

Standard: 1

Maximum (hard): 4

INSTRUMENT AND CONTROL FUNCTIONS

EAU01658

Matching the front and rear suspension settings

Use this table as a guide to match the suspension and damping adjustments of the front fork and shock absorber assembly according to various load conditions.

Load condition	Front fork adjustment	Shock absorber assembly adjustment	
	Spring preload (air pressure)	Spring preload	Damping force
Rider only	40–60 kPa 0.4–0.6 kgf/cm ² 5.7–8.5 psi	1–2	1–2
With passenger or with accessories and equipment	40–100 kPa 0.4–1.0 kgf/cm ² 5.7–14 psi	3–5	2–4
With passenger, accessories and equipment	40–100 kPa 0.4–1.0 kgf/cm ² 5.7–14 psi	5	4

EC000015

CAUTION:

Never attempt to turn an adjusting mechanism beyond the maximum or minimum settings.

INSTRUMENT AND CONTROL FUNCTIONS

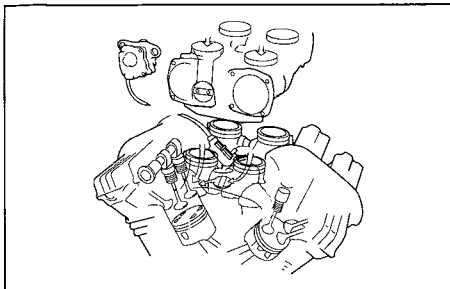

EAU00327

V-Boost

The V-Boost is a vital part of the engine and requires very sophisticated adjustment. Adjustment should be left to a Yamaha dealer who has the professional knowledge and experience to do so.

EC000025

CAUTION:

The V-Boost was set at the Yamaha factory after many tests. If the settings are changed by someone without sufficient technical knowledge, poor engine performance and damage may result.

The V-Boost operation can be heard when the main switch is turned on.

EC000026

CAUTION:

If the V-Boost does not operate, ask a Yamaha dealer to inspect it.

INSTRUMENT AND CONTROL FUNCTIONS

EAU00330

Sidestand

The sidestand is located on the left side of the frame. Raise the sidestand or lower it with your foot while holding the motorcycle upright.

NOTE:

The built-in sidestand switch is part of the ignition circuit cut-off system, which cuts the ignition in certain situations. (See further down for an explanation of the ignition circuit cut-off system.)

EW000044

WARNING

The motorcycle must not be ridden with the sidestand down, or if the sidestand cannot be properly moved up (or does not stay up), otherwise the sidestand could contact the ground and distract the operator, resulting in a possible loss of control. Yamaha's ignition circuit cut-off system has been designed to assist the operator in fulfilling the responsibility of raising the sidestand before starting off. Therefore, check this system regularly as described below and have a Yamaha dealer repair it if it does not function properly.

EAU00332

Ignition circuit cut-off system

The ignition circuit cut-off system (comprising the sidestand switch, clutch switch and neutral switch) has the following functions.

- It prevents starting when the transmission is in gear and the sidestand is up, but the clutch lever is not pulled.
- It prevents starting when the transmission is in gear and the clutch lever is pulled, but the sidestand is still down.
- It cuts the running engine when the sidestand is moved down.

Periodically check the operation of the ignition circuit cut-off system according to the following procedure.

EW000046

WARNING

- **The vehicle must be placed on the centerstand during this inspection.**
- **If a malfunction is noted, have a Yamaha dealer check the system before riding.**

INSTRUMENT AND CONTROL FUNCTIONS

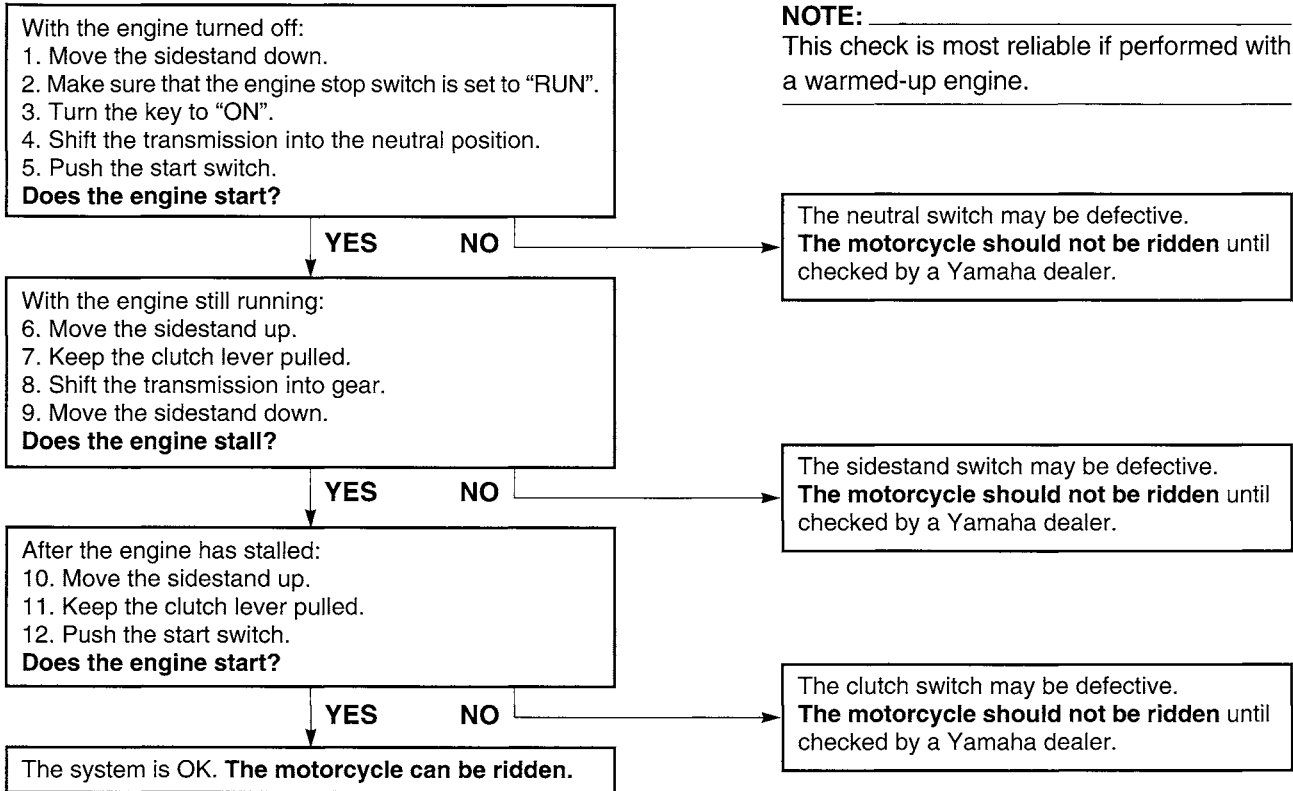

PRE-OPERATION CHECKS

Pre-operation check list 4-1

PRE-OPERATION CHECKS

The condition of a vehicle is the owner's responsibility. Vital components can start to deteriorate quickly and unexpectedly, even if the vehicle remains unused (for example, as a result of exposure to the elements). Any damage, fluid leakage or loss of tire air pressure could have serious consequences. Therefore, it is very important, in addition to a thorough visual inspection, to check the following points before each ride.

Pre-operation check list

ITEM	CHECKS	PAGE
Front brake	<ul style="list-style-type: none">• Check operation, free play, fluid level, and for fluid leakage.• Fill with DOT 4 brake fluid if necessary.	6-27-6-30
Rear brake		6-27-6-30
Clutch	<ul style="list-style-type: none">• Check operation, fluid level, and for fluid leakage.• Fill with DOT 4 brake fluid if necessary.	6-26, 6-29
Throttle grip and housing	<ul style="list-style-type: none">• Check operation.• Lubricate if necessary.	6-22, 6-31
Engine oil	<ul style="list-style-type: none">• Check oil level.• Add oil if necessary.	6-11-6-14
Coolant	<ul style="list-style-type: none">• Check coolant level.• Add coolant if necessary.	6-16-6-20
Final gear oil	<ul style="list-style-type: none">• Check vehicle for leakage.	6-15
Wheels and tires	<ul style="list-style-type: none">• Check tire air pressure, for wear and damage.	6-23-6-25
Control cables	<ul style="list-style-type: none">• Check operation.• Lubricate if necessary.	6-30
Brake and shift pedal shafts	<ul style="list-style-type: none">• Check operation.• Lubricate if necessary.	6-31
Brake and clutch lever pivots	<ul style="list-style-type: none">• Check operation.• Lubricate if necessary.	6-32
Center and sidestand pivots	<ul style="list-style-type: none">• Check operation.• Lubricate if necessary.	6-32

PRE-OPERATION CHECKS

ITEM	CHECKS	PAGE
Chassis fasteners	<ul style="list-style-type: none">• Make sure that all nuts, bolts and screws are properly tightened.• Tighten if necessary.	—
Fuel	<ul style="list-style-type: none">• Check fuel level.• Add fuel if necessary.	3-7
Lights, signals and switches	<ul style="list-style-type: none">• Check operation.	—
Battery	<ul style="list-style-type: none">• Check fluid level.• Add distilled water if necessary.	6-35–6-37

NOTE: Pre-operation checks should be made each time the motorcycle is used. Such an inspection can be accomplished in a very short time; and the added safety it assures is more than worth the time involved.

EWA00033

WARNING

If any item in the Pre-operation check list is not working properly, have it inspected and repaired before operating the motorcycle.

OPERATION AND IMPORTANT RIDING POINTS

Starting and warming up a cold engine	5-1
Starting a warm engine	5-3
Shifting	5-3
Engine break-in	5-5
Parking	5-6

EAU00373

⚠ WARNING

- Become thoroughly familiar with all operating controls and their functions before riding. Consult a Yamaha dealer regarding any control or function that you do not thoroughly understand.
- Never start the engine or operate it in a closed area for any length of time. Exhaust fumes are poisonous, and inhaling them can cause loss of consciousness and death within a short time. Always make sure that there is adequate ventilation.
- Before starting out, make sure that the sidestand is up. If the sidestand is not raised completely, it could contact the ground and distract the operator, resulting in a possible loss of control.

EAU00376

CAUTION:

- Make sure not to store personal items near the air cleaner intake, otherwise air intake will be blocked and performance will suffer.
- Make sure not to put anything near the battery and its terminals, otherwise electrical failure and acid corrosion may result.

EAU01164

Starting and warming up a cold engine

In order for the ignition circuit cut-off system to enable starting, one of the following conditions must be met:

- The transmission is in the neutral position.
- The transmission is in gear with the clutch lever pulled and the sidestand up.

EW000054

⚠ WARNING

- Before starting the engine, check the function of the ignition circuit cut-off system according to the procedure described on page 3-18.
- Never ride with the sidestand down.

1. Turn the key to “ON” and make sure that the engine stop switch is set to “RUN”.

OPERATION AND IMPORTANT RIDING POINTS

EC000035

CAUTION:

If the fuel level warning light comes on, check the fuel level, and, if necessary, refuel as soon as possible.

2. Shift the transmission into the neutral position.

NOTE:

When the transmission is in the neutral position, the neutral indicator light should be on, otherwise have a Yamaha dealer check the electrical circuit.

3. Turn the starter (choke) on and completely close the throttle. (See page 3-8 for starter (choke) operation.)
4. Start the engine by pushing the start switch.

NOTE:

If the engine fails to start, release the start switch, wait a few seconds, and then try again. Each starting attempt should be as short as possible to preserve the battery. Do not crank the engine more than 10 seconds on any one attempt.

EC000038

CAUTION:

- The oil level warning light and fuel level warning light should come on when the start switch is pushed, and they should go off when the start switch is released.
- If the oil level warning light flickers or remains on after starting, immediately stop the engine, and then check the engine oil level and the vehicle for oil leakage. If necessary, add engine oil, and then check the warning light again. If the warning light does not come on when pushing the start switch, or if it does

not go off after starting with sufficient engine oil, have a Yamaha dealer check the electrical circuit.

- If the fuel level warning light remains on after starting, stop the engine, and then check the fuel level. If necessary, refuel as soon as possible, and then check the warning light again. If the warning light does not come on when pushing the start switch, or if it does not go off after starting with sufficient fuel, have a Yamaha dealer check the electrical circuit.

5. After starting the engine, move the starter (choke) lever back halfway.

ECA00055

CAUTION:

For maximum engine life, always warm the engine up before starting off. Never accelerate hard when the engine is cold!

OPERATION AND IMPORTANT RIDING POINTS

- When the engine is warm, turn the starter (choke) off.

NOTE: _____

The engine is warm when it responds normally to the throttle with the starter (choke) turned off. To avoid the possibility of excessive exhaust emissions, never leave the starter (choke) on longer than necessary. The time necessary for starter (choke) use depends upon the ambient temperature. Temperatures above 10 °C (50 °F) require about 7 seconds of starter (choke) use and temperatures below 10 °C (50 °F) require about 35 seconds with the starter (choke) turned on, then about 2.5 minutes with the starter (choke) in the half-way position.

Starting a warm engine

EAU01258

Follow the same procedure as for starting a cold engine with the exception that the starter (choke) is not required when the engine is warm.

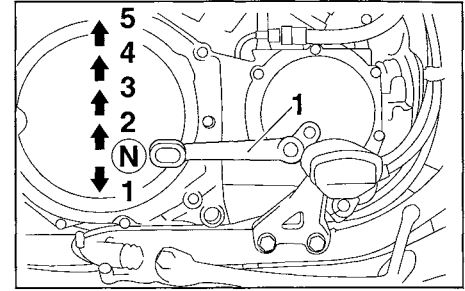

- 1. Shift pedal
- N. Neutral position

EAU00423

Shifting

Shifting gears lets you control the amount of engine power available for starting off, accelerating, climbing hills, etc.

The gear positions are shown in the illustration.

NOTE: _____

To shift the transmission into the neutral position, press the shift pedal down repeatedly until it reaches the end of its travel, and then slightly raise it.

OPERATION AND IMPORTANT RIDING POINTS

EC000048

EAU02988

EAU00427

CAUTION:

- **Even with the transmission in the neutral position, do not coast for long periods of time with the engine off, and do not tow the motorcycle for long distances. The transmission is properly lubricated only when the engine is running. Inadequate lubrication may damage the transmission.**
- **Always use the clutch while changing gears to avoid damaging the engine, transmission, and drive train, which are not designed to withstand the shock of forced shifting.**

To start out and accelerate

1. Pull the clutch lever to disengage the clutch.
2. Shift the transmission into first gear. The neutral indicator light should go out.
3. Open the throttle gradually, and at the same time, release the clutch lever slowly.
4. At the recommended shift points shown in the table on page 5-5, close the throttle, and at the same time, quickly pull the clutch lever in.
5. Shift the transmission into second gear. (Make sure not to shift the transmission into the neutral position.)
6. Open the throttle part way and gradually release the clutch lever.
7. Follow the same procedure when shifting to the next higher gear.

NOTE:

Always shift gears at the recommended shift points.

To decelerate

1. Apply both the front and the rear brakes to slow the motorcycle.
2. Shift the transmission into first gear when the motorcycle reaches 20 km/h (12.5 mi/h). If the engine is about to stall or runs very roughly, pull the clutch lever in and use the brakes to stop the motorcycle.
3. Shift the transmission into the neutral position when the motorcycle is almost completely stopped. The neutral indicator light should come on.

OPERATION AND IMPORTANT RIDING POINTS

EAU02974

Recommended shift points

The recommended shift points during acceleration and deceleration are shown in the table below.

	Acceleration shift point km/h (mi/h)	Deceleration shift point km/h (mi/h)
1st → 2nd	16 (10.0)	20 (12.5)
2nd → 3rd	24 (15.0)	20 (12.5)
3rd → 4th	32 (20.0)	20 (12.5)
4th → 5th	40 (25.0)	20 (12.5)

Engine break-in

There is never a more important period in the life of your engine than the period between 0 and 1,000 km (600 mi). For this reason, you should read the following material carefully.

Since the engine is brand new, do not put an excessive load on it for the first 1,000 km (600 mi). The various parts in the engine wear and polish themselves to the correct operating clearances. During this period, prolonged full-throttle operation or any condition that might result in engine overheating must be avoided.

EAU00436

0–150 km (0–90 mi)

- Avoid prolonged operation above 4,500 r/min.
- After every hour of operation, stop the engine, and then let it cool for five to ten minutes.
- Vary the engine speed from time to time. Do not operate the engine at one set throttle position.

150–500 km (90–300 mi)

- Avoid prolonged operation above 5,500 r/min.
- Rev the engine freely through the gears, but do not use full throttle at any time.

500–1,000 km (300–600 mi)

- Avoid prolonged full-throttle operation.
- Avoid prolonged operation above 6,500 r/min.

EAU00442

OPERATION AND IMPORTANT RIDING POINTS

EC000056

CAUTION:

After 1,000 km (600 mi) of operation, the engine oil and final gear oil must be changed, and the oil filter cartridge replaced.

1,000 km (600 mi) and beyond

The vehicle can now be operated normally.

EC000053

CAUTION:

- Keep the engine speed out of the tachometer red zone.
- If any engine trouble should occur during the engine break-in period, immediately have a Yamaha dealer check the vehicle.

EAU00460

Parking

When parking, stop the engine, and then remove the key from the main switch.

EW000058

⚠ WARNING

- Since the engine and exhaust system can become very hot, park in a place where pedestrians or children are not likely to touch them.
- Do not park on a slope or on soft ground, otherwise the motorcycle may overturn.

PERIODIC MAINTENANCE AND MINOR REPAIR

Periodic maintenance	6-1	Checking the brake fluid level	6-29
Owner's tool kit	6-1	Changing the brake fluid	6-30
Periodic maintenance chart for emission control system	6-3	Checking and lubricating the cables	6-30
General maintenance and lubrication chart	6-5	Checking and lubricating the throttle grip and cable	6-31
Removing and installing cowlings and panels	6-8	Checking and lubricating the brake and shift pedals	6-31
Checking the spark plugs	6-9	Checking and lubricating the brake and clutch levers	6-32
Canister (for California only)	6-11	Checking and lubricating the centerstand and sidestand	6-32
Engine oil and oil filter cartridge	6-11	Lubricating the rear suspension	6-33
Final gear oil	6-15	Checking the front fork	6-33
Coolant	6-16	Checking the steering	6-34
Cleaning the air filter element	6-21	Checking the wheel bearings	6-35
Adjusting the carburetors	6-22	Battery	6-35
Adjusting the throttle cable free play	6-22	Replacing the fuses	6-39
Adjusting the valve clearance	6-22	Replacing the headlight bulb	6-40
Tires	6-23	Replacing a turn signal light bulb or the tail/brake light bulb	6-41
Cast wheels	6-25	Front wheel	6-42
Accessories and replacement parts	6-25	Rear wheel	6-43
Clutch lever free play	6-26	Troubleshooting	6-45
Adjusting the brake lever free play	6-27	Troubleshooting charts	6-46
Adjusting the brake pedal position	6-27		
Adjusting the rear brake light switch	6-28		
Checking the front and rear brake pads	6-28		

EAU01790

Safety is an obligation of the owner. Periodic inspection, adjustment and lubrication will keep your vehicle in the safest and most efficient condition possible. The most important points of motorcycle inspection, adjustment, and lubrication are explained on the following pages.

Maintenance, replacement, or repair of the emission control devices and systems may be performed by any repair establishment or individual that is certified (if applicable).

EW000060

WARNING

If you are not familiar with motorcycle maintenance work, have a Yamaha dealer do it for you.

EAU00467

PERIODIC MAINTENANCE

PROPER PERIODIC MAINTENANCE OF YOUR MOTORCYCLE IS IMPORTANT IN ORDER TO ENJOY LONG, PLEASURABLE SERVICE. ESPECIALLY IMPORTANT ARE THE MAINTENANCE SERVICES RELATED TO EMISSIONS CONTROL. THESE CONTROLS NOT ONLY FUNCTION TO ENSURE CLEANER AIR, BUT ARE ALSO VITAL TO PROPER ENGINE OPERATION AND MAXIMUM PERFORMANCE. IN THE FOLLOWING PERIODIC MAINTENANCE CHARTS, THE SERVICES RELATED TO EMISSIONS CONTROL ARE GROUPED SEPARATELY. THESE SERVICES REQUIRE SPECIALIZED DATA, KNOWLEDGE, AND EQUIPMENT. YAMAHA DEALERS ARE TRAINED AND EQUIPPED TO PERFORM THESE PARTICULAR SERVICES.

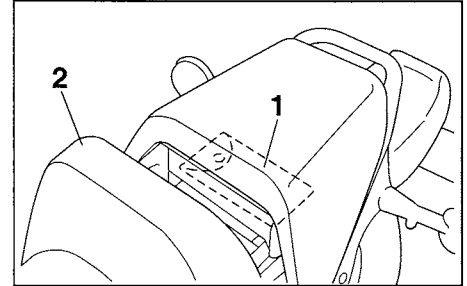

1. Owner's tool kit
2. Rider seat backrest

EAU01659

Owner's tool kit

The tool kit is located inside the storage compartment behind the rider seat backrest. (See page 3-9 for an explanation on moving the rider seat backrest forward and back.)

PERIODIC MAINTENANCE AND MINOR REPAIR

EW000063

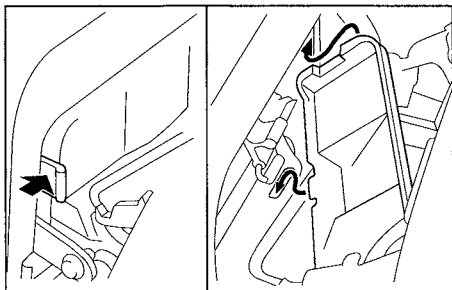

! WARNING

Modifications not approved by Yamaha may cause loss of performance and render the vehicle unsafe for use. Consult a Yamaha dealer before attempting any changes.

The service information included in this manual and the tools provided in the owner's tool kit are intended to assist you in the performance of preventive maintenance and minor repairs. However, additional tools such as a torque wrench may be necessary to perform certain maintenance work correctly.

NOTE:
If you do not have the tools or experience required for a particular job, have a Yamaha dealer perform it for you.

PERIODIC MAINTENANCE AND MINOR REPAIR

EAU00471

Periodic maintenance chart for emission control system

No.	ITEM	ROUTINE	INITIAL	ODOMETER READINGS					
			600 mi (1,000 km) or 1 month	4,000mi (7,000 km) or 6 months	8,000 mi (13,000 km) or 12 months	12,000 mi (19,000 km) or 18 months	16,000 mi (25,000 km) or 24 months	20,000 mi (31,000 km) or 30 months	
1 *	Valve clearance	<ul style="list-style-type: none"> Check and adjust valve clearance when engine is cold. 	Every 30,000 mi (42,000 km) or 42 months						
2	Spark plugs	<ul style="list-style-type: none"> Check condition. Adjust gap and clean. Replace every 8,000 mi (13,000 km) or 12 months and thereafter every 8,000 mi (13,000 km) or 12 months. 		√	Replace.	√	Replace.	√	
3 *	Crankcase ventilation system	<ul style="list-style-type: none"> Check ventilation hose for cracks or damage. Replace if necessary. 		√	√	√	√	√	
4 *	Fuel line	<ul style="list-style-type: none"> Check fuel hoses for cracks or damage. Replace if necessary. 		√	√	√	√	√	
5 *	Fuel filter	<ul style="list-style-type: none"> Replace initial 20,000 mi (31,000 km) or 30 months and thereafter every 20,000 mi (31,000 km) or 30 months. 						Replace.	
6 *	Exhaust system	<ul style="list-style-type: none"> Check for leakage. Retighten if necessary. Replace gasket(s) if necessary. 		√	√	√	√	√	
7 *	Carburetor synchronization	<ul style="list-style-type: none"> Adjust synchronization of carburetors. 	√	√	√	√	√	√	
8 *	Idle speed	<ul style="list-style-type: none"> Check and adjust engine idle speed. Adjust cable free play. 		√	√	√	√	√	

PERIODIC MAINTENANCE AND MINOR REPAIR

No.	ITEM	ROUTINE	INITIAL	ODOMETER READINGS					
			600 mi (1,000 km) or 1 month	4,000mi (7,000 km) or 6 months	8,000 mi (13,000 km) or 12 months	12,000 mi (19,000 km) or 18 months	16,000 mi (25,000 km) or 24 months	20,000 mi (31,000 km) or 30 months	
9 *	Evaporative emission control system (For California only)	<ul style="list-style-type: none"> • Check control system for damage. • Replace if necessary. 				√		√	

* Since these items require special tools, data and technical skills, have a Yamaha dealer perform the service.

PERIODIC MAINTENANCE AND MINOR REPAIR

EAU00472

General maintenance and lubrication chart

No.	ITEM	ROUTINE	TYPE	INITIAL	ODOMETER READINGS					
				600 mi (1,000 km) or 1 month	4,000 mi (7,000 km) or 6 months	8,000 mi (13,000 km) or 12 months	12,000 mi (19,000 km) or 18 months	16,000 mi (25,000 km) or 24 months	20,000 mi (31,000 km) or 30 months	
1	Engine oil	<ul style="list-style-type: none"> Replace (warm up engine before draining). 	See page 8-1.	√	√	√	√	√	√	
2	Oil filter	<ul style="list-style-type: none"> Replace. 	—	√		√		√		
3	* Air filter	<ul style="list-style-type: none"> Clean with compressed air. Replace if necessary. 	—		√	√	√	√	√	
4	* Cooling system	<ul style="list-style-type: none"> Check hose for cracks or damage. Replace if necessary. 	—		√	√	√	√	√	
		<ul style="list-style-type: none"> Replace coolant every 24 months. 	Ethylene glycol antifreeze coolant					Replace.		
5	* Brake system	<ul style="list-style-type: none"> Adjust free play. Replace pads if necessary. 	—	√	√	√	√	√	√	
6	* Clutch	<ul style="list-style-type: none"> Check operation and fluid leakage. (See NOTE page 6-7.) Correct if necessary. 	—	√	√	√	√	√	√	
7	Final gear oil	<ul style="list-style-type: none"> Check oil level and leakage. Replace every 16,000 mi (25,000 km) or 24 months. 	SAE 80 API "GL-4" hypoid gear oil	Replace.	√	√	√	Replace.	√	
8	Control and meter cable	<ul style="list-style-type: none"> Apply chain lube thoroughly. 	Yamaha chain and cable lube or SAE 10W-30 motor oil	√	√	√	√	√	√	

PERIODIC MAINTENANCE AND MINOR REPAIR

No.	ITEM	ROUTINE	TYPE	INITIAL	ODOMETER READINGS					
				600 mi (1,000 km) or 1 month	4,000 mi (7,000 km) or 6 months	8,000 mi (13,000 km) or 12 months	12,000 mi (19,000 km) or 18 months	16,000 mi (25,000 km) or 24 months	20,000 mi (31,000 km) or 30 months	
9	* Swingarm pivot bearing	<ul style="list-style-type: none"> • Check bearing assembly for looseness. • Moderately repack every 16,000 mi (25,000 km). 	Lithium-soap-based grease			√			Repack.	
10	Brake/clutch lever pivot shaft	<ul style="list-style-type: none"> • Apply lithium-soap-based grease (all-purpose grease) lightly. 	Lithium-soap-based grease (all-purpose grease)		√	√	√	√	√	√
11	Brake pedal and shift pedal shaft	<ul style="list-style-type: none"> • Lubricate. • Apply lithium-soap-based grease (all-purpose grease) lightly. 	Lithium-soap-based grease (all-purpose grease)		√	√	√	√	√	√
12	* Center/sidestand pivots	<ul style="list-style-type: none"> • Check operation and lubricate. • Apply lithium-soap-based grease (all-purpose grease) lightly. 	Lithium-soap-based grease (all-purpose grease)		√	√	√	√	√	√
13	* Front fork	<ul style="list-style-type: none"> • Check operation and leakage. 	-		√	√	√	√	√	√
14	* Steering bearings	<ul style="list-style-type: none"> • Check bearing assembly for looseness. • Moderately repack every 16,000 mi (25,000 km). 	Lithium-soap-based grease		√	√	√		Repack.	√
15	* Wheel bearings	<ul style="list-style-type: none"> • Check bearings for smooth rotation. 	-		√	√	√	√	√	√
16	* Battery	<ul style="list-style-type: none"> • Check specific gravity and breather pipe for proper operation. 	-		√	√	√	√	√	√

PERIODIC MAINTENANCE AND MINOR REPAIR

No.	ITEM	ROUTINE	TYPE	INITIAL	ODOMETER READINGS					
				600 mi (1,000 km) or 1 month	4,000 mi (7,000 km) or 6 months	8,000 mi (13,000 km) or 12 months	12,000 mi (19,000 km) or 18 months	16,000 mi (25,000 km) or 24 months	20,000 mi (31,000 km) or 30 months	
17	* Sidestand switch	* Check and clean or replace if necessary.	-	√	√	√	√	√	√	

* Since these items require special tools, data and technical skills, they should be serviced by a Yamaha dealer.

EAU01695

NOTE: For odometer readings or time periods higher than 20,000 mi (31,000 km) or 30 months, follow the maintenance requirements listed in the maintenance chart under the 4,000 mi (7,000 km) or 6 month interval.

EAU03058

NOTE:

- The air filter needs more frequent service if you are riding in unusually wet or dusty areas.
- Hydraulic brake and clutch systems
- After disassembling the master cylinder, caliper cylinder or clutch release cylinder, always replace the brake fluid. Check the brake fluid level of the master cylinder and clutch release cylinder regularly and fill as required.
- Replace the oil seals on the inner parts of the master cylinder, caliper cylinder and clutch release cylinder every two years.
- Replace the brake and clutch hoses every four years or if cracked or damaged.

PERIODIC MAINTENANCE AND MINOR REPAIR

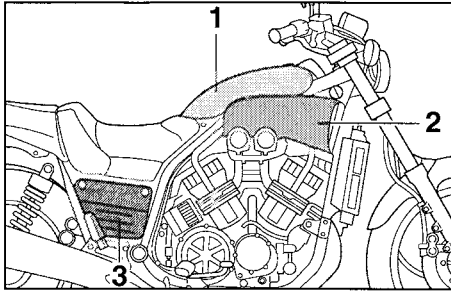

1. Cowling A
2. Panel A
3. Panel B

Removing and installing cowlings and panels

EAU01139

The cowlings and panels shown above need to be removed to perform some of the maintenance jobs described in this chapter. Refer to this section each time a cowling or panel needs to be removed and installed.

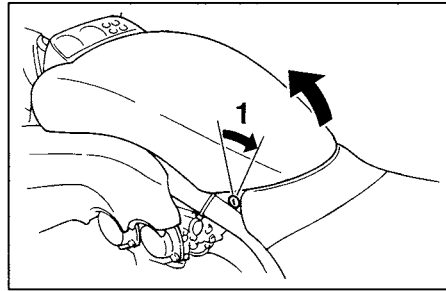

1. Unlock.

EAU03415

Cowling A

To remove the cowling

1. Insert the key into the lock, and then turn it clockwise.
2. Pull the cowling off as shown.

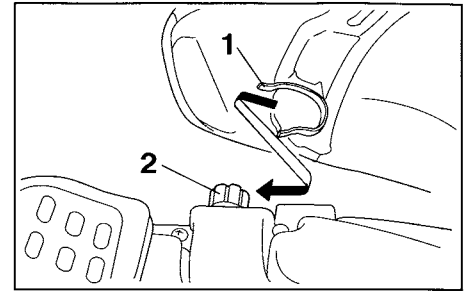

1. Holder (× 2)
2. Projection (× 2)

To install the cowling

1. Align the holders under the cowling with the projections on the frame.
2. Push down on the rear of the cowling until it locks in place.
3. Remove the key from the lock.

PERIODIC MAINTENANCE AND MINOR REPAIR

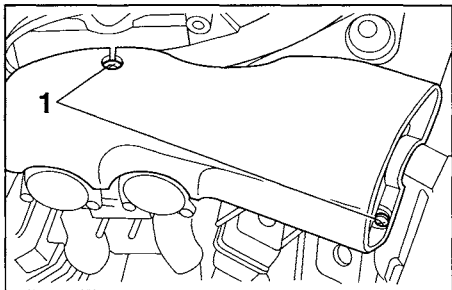

1. Screw (× 2)

EAU03340

Panel A

To remove the panel

1. Remove cowling A. (See page 6-8 for cowling removal and installation procedures.)
2. Remove the screws, and then take the panel off.

To install the panel

1. Place the panel in the original position, and then install the screws.
2. Install the cowling.

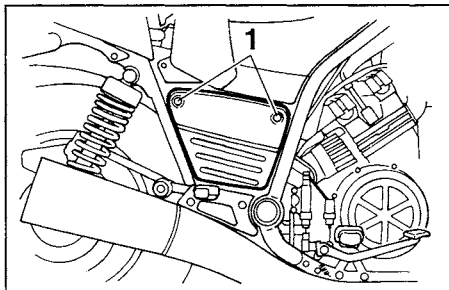

1. Screw (× 2)

EAU01315

Panel B

To remove the panel

Remove the screws, and then take the panel off.

To install the panel

Place the panel in the original position, and then install the screws.

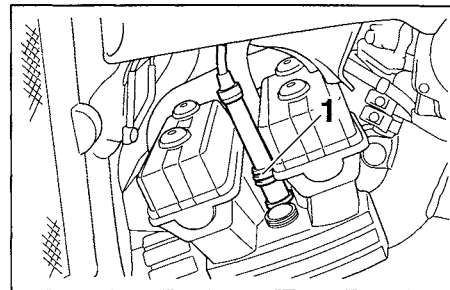

1. Spark plug cap

EAU03329

Checking the spark plugs

The spark plugs are important engine components, which are easy to check. Since heat and deposits will cause any spark plug to slowly erode, the spark plugs should be removed and checked in accordance with the periodic maintenance and lubrication chart. In addition, the condition of the spark plugs can reveal the condition of the engine.

To remove a spark plug

1. Remove the spark plug cap.

PERIODIC MAINTENANCE AND MINOR REPAIR

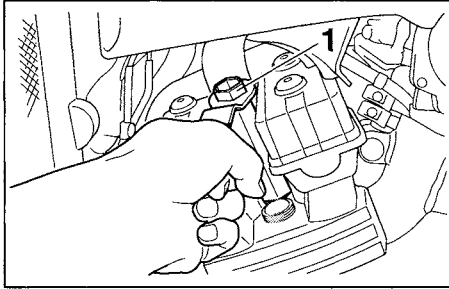

1. Spark plug wrench

2. Remove the spark plug as shown, with the spark plug wrench included in the owner's tool kit.

To check the spark plugs

1. Check that the porcelain insulator around the center electrode on each spark plug is a medium-to-light tan (the ideal color when the motorcycle is ridden normally).
2. Check that all spark plugs installed in the engine have the same color.

NOTE:

If any spark plug shows a distinctly different color, the engine could be defective. Do not attempt to diagnose such problems yourself. Instead, have a Yamaha dealer check the motorcycle.

3. Check each spark plug for electrode erosion and excessive carbon or other deposits, and replace it if necessary.

Specified spark plug:
DPR8EA-9/NGK or
X24EPR-U9/DENSO

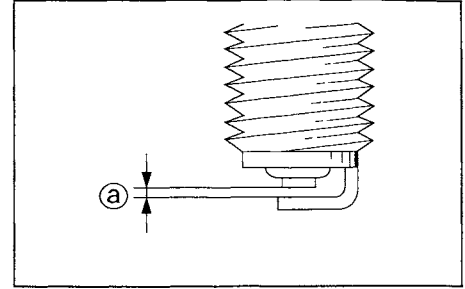

a. Spark plug gap

To install a spark plug

1. Measure the spark plug gap with a wire thickness gauge and, if necessary, adjust the gap to specification.

Spark plug gap:
0.8–0.9 mm (0.03–0.04 in)

2. Clean the surface of the spark plug gasket and its mating surface, and then wipe off any grime from the spark plug threads.
3. Install the spark plug with the spark plug wrench, and then tighten it to the specified torque.

PERIODIC MAINTENANCE AND MINOR REPAIR

EAU02938

Tightening torque:
Spark plug:
18 Nm (1.8 m·kg, 13 ft·lb)

NOTE: _____
If a torque wrench is not available when installing a spark plug, a good estimate of the correct torque is 1/4–1/2 turn past finger tight. However, the spark plug should be tightened to the specified torque as soon as possible.

4. Install the spark plug cap.

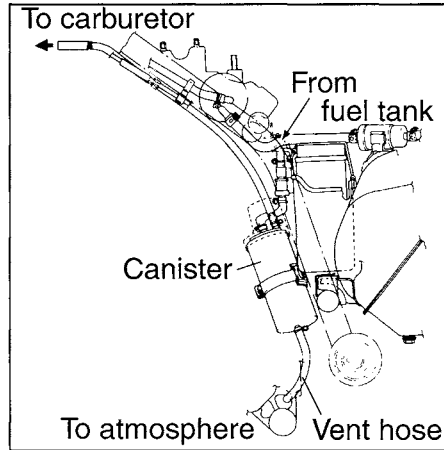

EAU01796

Canister (for California only)

This model is equipped with a canister to prevent the discharging of fuel vapor into the atmosphere.

- Check each hose connection.
- Check each hose and canister for cracks or damage. Replace if damaged.
- Make sure the vent hose is not blocked. Clean it if necessary.

Engine oil and oil filter cartridge

The engine oil level should be checked before each ride. In addition, the oil must be changed and the oil filter cartridge replaced at the intervals specified in the periodic maintenance and lubrication chart.

To check the engine oil level

1. Place the motorcycle on the centerstand.

NOTE: _____
Make sure that the motorcycle is positioned straight up when checking the oil level. A slight tilt to the side can result in a false reading.

2. Start the engine, warm it up for several minutes, and then turn it off.

PERIODIC MAINTENANCE AND MINOR REPAIR

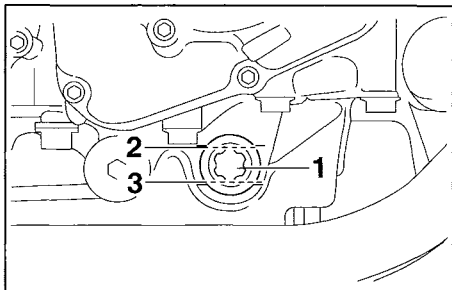

1. Engine oil level check window
2. Maximum level mark
3. Minimum level mark

3. Wait a few minutes until the oil settles, and then check the oil level through the check window located at the bottom-right side of the crankcase.

NOTE: _____
The engine oil should be between the minimum and maximum level marks.

4. If the engine oil is below the minimum level mark, add sufficient oil of the recommended type to raise it to the correct level.

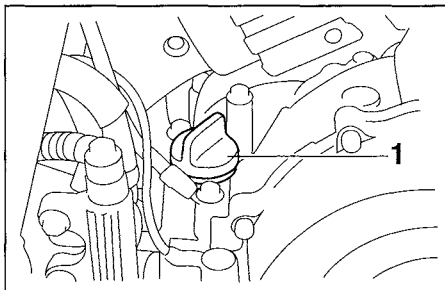

1. Engine oil filler cap

To change the engine oil (with or without oil filter cartridge replacement)

1. Start the engine, warm it up for several minutes, and then turn it off.
2. Place an oil pan under the engine to collect the used oil.

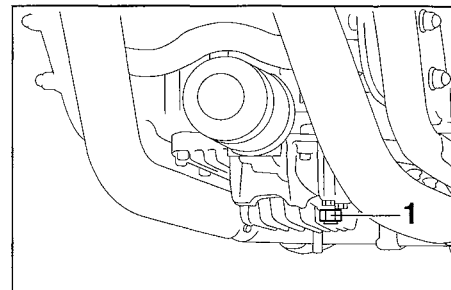

1. Engine oil drain bolt

3. Remove the engine oil filler cap and drain bolt to drain the oil from the crankcase.

NOTE: _____
Skip steps 4–6 if the oil filter cartridge is not being replaced.

PERIODIC MAINTENANCE AND MINOR REPAIR

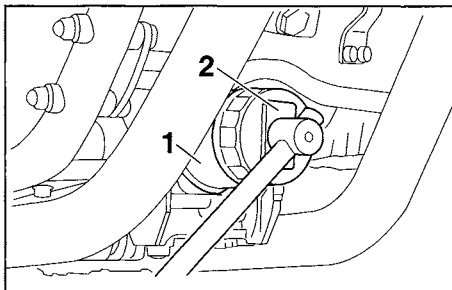

1. Oil filter cartridge
2. Oil filter wrench

4. Remove the oil filter cartridge with an oil filter wrench.

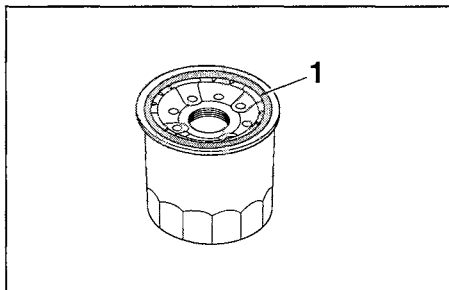

1. O-ring

5. Apply a thin coat of engine oil to the O-ring of the new oil filter cartridge.

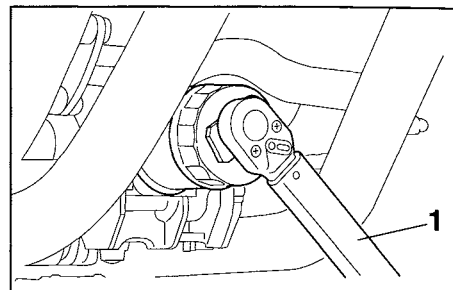

1. Torque wrench

6. Install the new oil filter cartridge, and then tighten it to the specified torque with a torque wrench.

NOTE: _____
An oil filter wrench is available at a Yamaha dealer.

NOTE: _____
Make sure that the O-ring is properly seated.

Tightening torque:
Oil filter cartridge:
17 Nm (1.7 m·kg, 12 ft·lb)

7. Install the engine oil drain bolt, and then tighten it to the specified torque.

Tightening torque:
Engine oil drain bolt:
43 Nm (4.3 m·kg, 31 ft·lb)

PERIODIC MAINTENANCE AND MINOR REPAIR

8. Add the specified amount of the recommended engine oil, and then install and tighten the oil filler cap.

Recommended engine oil:

See page 8-1.

Oil quantity:

Without oil filter cartridge replacement:

3.2 L (2.8 Imp qt, 3.4 US qt)

With oil filter cartridge replacement:

3.4 L (3.0 Imp qt, 3.6 US qt)

Total amount (dry engine):

4.0 L (3.5 Imp qt, 4.2 US qt)

EC000072

CAUTION:

- In order to prevent clutch slippage (since the engine oil also lubricates the clutch), do not mix any chemical additives with the oil or use oils of a higher grade than “CD”. In addition, do not use oils labeled “ENERGY CONSERVING II” or higher.
- Make sure that no foreign material enters the crankcase.

9. Start the engine, and then let it idle for several minutes while checking it for oil leakage. If oil is leaking, immediately turn the engine off and check for the cause.

NOTE:

After the engine is started, the engine oil level warning light should go off if the oil level is sufficient.

EC000067

CAUTION:

If the oil level warning light flickers or remains on, immediately turn the engine off and have a Yamaha dealer check the vehicle.

10. Turn the engine off, and then check the oil level and correct it if necessary.

PERIODIC MAINTENANCE AND MINOR REPAIR

EAU02975

Final gear oil

The final gear case must be checked for oil leakage before each ride. If any leakage is found, have a Yamaha dealer check and repair the motorcycle. In addition, the final gear oil must be changed as follows at the intervals specified in the periodic maintenance and lubrication chart.

1. Place the motorcycle on the centerstand.
2. Place an oil pan under the final gear case to collect the used oil.

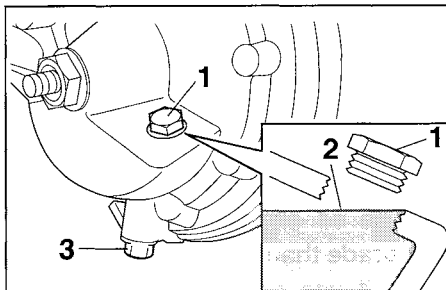

1. Final gear oil filler bolt
 2. Correct oil level
 3. Final gear oil drain bolt
3. Remove the oil filler bolt and drain bolt to drain the oil from the final gear case.
 4. Install the final gear oil drain bolt, and then tighten it to the specified torque.

Tightening torque:

Final gear oil drain bolt:

23 Nm (2.3 m·kg, 17 ft·lb)

5. Add the specified amount of the recommended final gear oil, and then install and tighten the oil filler bolt.

Recommended final gear oil:

Hypoid gear oil SAE 80 (API GL4)
or multigrade hypoid gear oil SAE
80W-90

Oil quantity:

0.2 L (0.18 Imp qt, 0.21 US qt)

NOTE:

GL4 is a quality rating. Hypoid gear oils rated GL5 or GL6 may also be used.

EW000066

WARNING

- Make sure that no foreign material enters the final gear case.
- Make sure that no oil gets on the tire or wheel.

6. Check the final gear case for oil leakage. If oil is leaking, check for the cause.

PERIODIC MAINTENANCE AND MINOR REPAIR

EAU03416

Coolant

The coolant level should be checked before each ride. In addition, the coolant must be changed at the intervals specified in the periodic maintenance and lubrication chart.

If the engine overheats, see page 6-47 for further instructions.

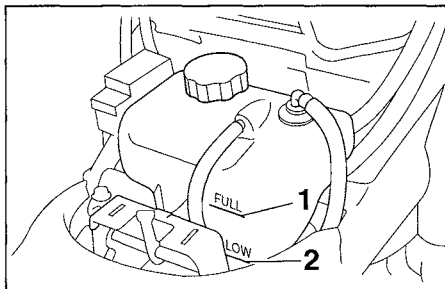

1. Maximum level mark
2. Minimum level mark

To check the coolant level

1. Place the motorcycle on a level surface and hold it in an upright position.
2. Remove cowling A. (See page 6-8 for cowling removal and installation procedures.)

NOTE:

- The coolant level must be checked on a cold engine since the level varies with engine temperature.
- Make sure that the motorcycle is positioned straight up when checking the coolant level. A slight tilt to the side can result in a false reading.

3. Check the coolant level in the coolant reservoir.

NOTE:

The coolant should be between the minimum and maximum level marks.

4. If the coolant is at or below the minimum level mark, remove the coolant reservoir cap and add coolant to the maximum level mark.
5. Install the coolant reservoir cap and the cowling.

Coolant reservoir capacity:
0.3 L (0.26 Imp, 0.32 US qt)

PERIODIC MAINTENANCE AND MINOR REPAIR

EC000080

CAUTION:

- If coolant is not available, use distilled water or soft tap water instead. Do not use hard water or salt water since it is harmful to the engine.
- If water has been used instead of coolant, replace it with coolant as soon as possible, otherwise the engine may not be sufficiently cooled and the cooling system will not be protected against frost and corrosion.
- If water has been added to the coolant, have a Yamaha dealer check the antifreeze content of the coolant as soon as possible, otherwise the effectiveness of the coolant will be reduced.

EW000067

WARNING

Never attempt to remove the radiator cap when the engine is hot.

NOTE:

The radiator fan is automatically switched on or off according to the coolant temperature in the radiator. If the engine overheats, see page 6-47 for further instructions.

EAU03417

To change the coolant

1. Place the motorcycle on a level surface and let the engine cool if necessary.
2. Remove cowl A and panel A. (See pages 6-8 and 6-9 for cowl and panel removal and installation procedures.)
3. Place a container under the engine to collect the used coolant.

PERIODIC MAINTENANCE AND MINOR REPAIR

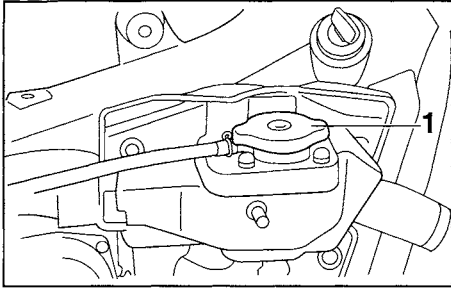

1. Radiator cap

4. Remove the radiator cap.

EW000067

WARNING

Never attempt to remove the radiator cap when the engine is hot.

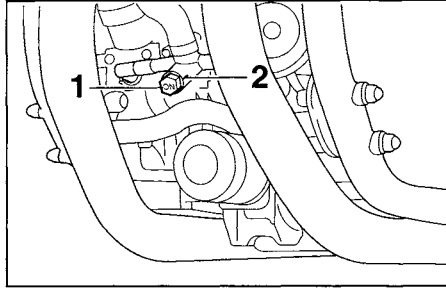

1. Coolant drain cock

2. Position indicator

5. Turn the coolant drain cock to "ON".

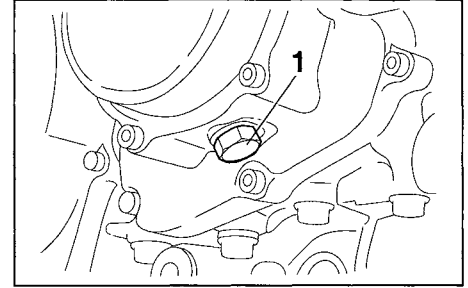

1. Water pump drain bolt

6. Remove the water pump drain bolt to drain the water pump housing.

PERIODIC MAINTENANCE AND MINOR REPAIR

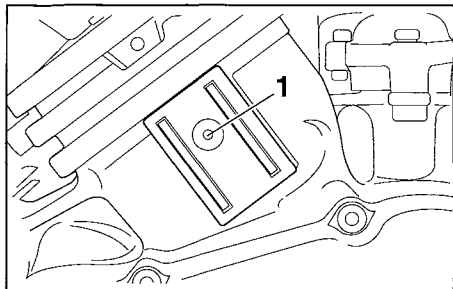

1. Screw (× 4)

7. Remove the cylinder drain plug covers on the outside of the cylinder blocks by removing the screws.

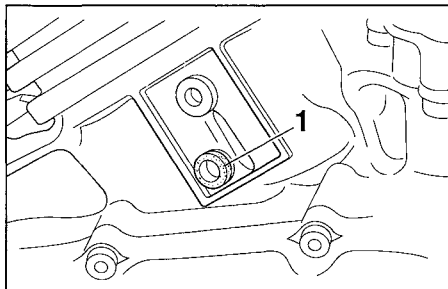

1. Rubber coolant drain plug (× 4)

8. Remove the rubber coolant drain plugs to drain the coolant from the engine.
9. After the coolant is completely drained, thoroughly flush the cooling system with clean tap water.
10. Install the water pump drain bolt, and then tighten it to the specified torque.

NOTE:

Check the washer for damage and replace it if necessary.

Tightening torque:

Water pump drain bolt:

43 Nm (4.3 m·kg, 31 ft·lb)

11. Install the rubber coolant drain plugs, and then install the cylinder drain plug covers.

NOTE:

Check the rubber plugs for damage and replace them if necessary.

12. Turn the coolant drain cock to "OFF".
13. Pour the recommended coolant into the reservoir to the maximum level, and then install the cap.
14. Pour the recommended coolant into the radiator until it is full.

PERIODIC MAINTENANCE AND MINOR REPAIR

Antifreeze/water mixture ratio:

1:1

Recommended antifreeze:

High-quality ethylene glycol antifreeze containing corrosion inhibitors for aluminum engines

Coolant quantity:

Total amount:

3.05 L (2.68 Imp qt, 3.22 US qt)

Coolant reservoir capacity:

0.3 L (0.26 Imp qt, 0.32 US qt)

EC000080

CAUTION:

- **If coolant is not available, use distilled water or soft tap water instead. Do not use hard water or salt water since it is harmful to the engine.**
- **If water has been used instead of coolant, replace it with coolant as soon as possible, otherwise the engine may not be sufficiently cooled and the cooling system will not be protected against frost and corrosion.**

- **If water has been added to the coolant, have a Yamaha dealer check the antifreeze content of the coolant as soon as possible, otherwise the effectiveness of the coolant will be reduced.**

15. Install the radiator cap, start the engine, let it idle for several minutes, and then turn it off.
16. Remove the radiator cap to check the coolant level in the radiator. If necessary, add sufficient coolant until it reaches the top of the radiator, and then install the radiator cap.
17. Check the coolant level in the reservoir. If necessary, remove the coolant reservoir cap, add coolant to the maximum level mark, and then install the cap.
18. Start the engine, and then check the vehicle for coolant leakage. If coolant is leaking, have a Yamaha dealer check the cooling system.
19. Install the cowl and the panel.

PERIODIC MAINTENANCE AND MINOR REPAIR

EC000082

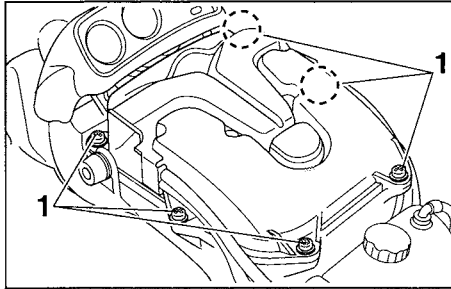

1. Screw (× 6)

EAU01662

Cleaning the air filter element

The air filter element should be cleaned at the intervals specified in the periodic maintenance and lubrication chart. Clean the air filter element more frequently if you are riding in unusually wet or dusty areas.

1. Remove cowling A. (See page 6-8 for cowling removal and installation procedures.)
2. Remove the air filter case cover by removing the screws.

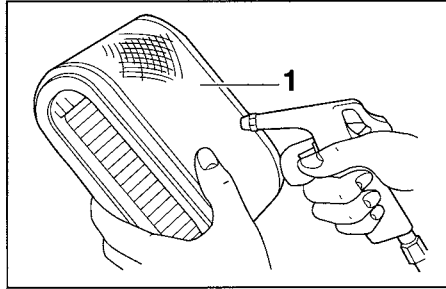

1. Air filter element

3. Pull the air filter element out.
4. Lightly tap the air filter element to remove most of the dust and dirt, and then blow the remaining dirt out with compressed air as shown. If the air filter element is damaged, replace it.
5. Insert the air filter element into the air filter case.

CAUTION:

- Make sure that the air filter element is properly seated in the air filter case.
- The engine should never be operated without the air filter element installed, otherwise the piston(s) and/or cylinder(s) may become excessively worn.

6. Install the air filter case cover by installing the screws.
7. Install the cowling.

EAU00628

Adjusting the carburetors

The carburetors are important parts of the engine and emission control system, which require very sophisticated adjustment. Therefore, all carburetor adjustments should be left to a Yamaha dealer, who has the necessary professional knowledge and experience.

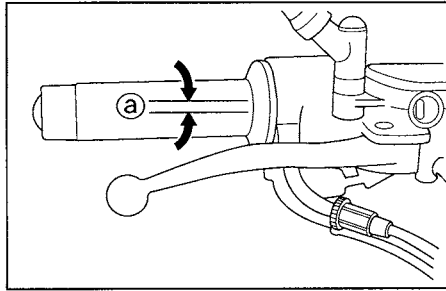

a. Throttle cable free play

EAU00635

Adjusting the throttle cable free play

The throttle cable free play should measure 3–5 mm (0.12–0.20 in) at the throttle grip. Periodically check the throttle cable free play and, if necessary, have a Yamaha dealer adjust it.

EAU00637

Adjusting the valve clearance

The valve clearance changes with use, resulting in improper air-fuel mixture and/or engine noise. To prevent this from occurring, the valve clearance must be adjusted by a Yamaha dealer at the intervals specified in the periodic maintenance and lubrication chart.

PERIODIC MAINTENANCE AND MINOR REPAIR

EAU03360

Tires

To maximize the performance, durability, and safe operation of your motorcycle, note the following points regarding the specified tires.

Tire air pressure

The tire air pressure should be checked and, if necessary, adjusted before each ride.

EW000082

WARNING

- The tire air pressure must be checked and adjusted on cold tires (i.e., when the temperature of the tires equals the ambient temperature).
- The tire air pressure must be adjusted in accordance with the riding speed and with the total weight of rider, passenger, cargo, and accessories approved for this model.

Tire air pressure (measured on cold tires)		
Load*	Front	Rear
Up to 90 kg (198 lb)	225 kPa 2.25 kgf/cm ² 33 psi	225 kPa 2.25 kgf/cm ² 33 psi
90 kg (198 lb)– maximum	225 kPa 2.25 kgf/cm ² 33 psi	2.50 kPa 2.50 kgf/cm ² 36 psi
High-speed riding	225 kPa 2.25 kgf/cm ² 33 psi	2.50 kPa 2.50 kgf/cm ² 36 psi

Maximum load*	216 kg (476 lb): VMX12 215 kg (474 lb): VMX12C
---------------	---

* Total weight of rider, passenger, cargo and accessories

EW000083

WARNING

Proper loading of your motorcycle is important for several characteristics of your motorcycle, such as handling, braking, performance and safety. Do not carry loosely packed items that can shift. Securely pack your heaviest items close to the center of the motorcycle, and distribute the weight evenly from side to side. Properly adjust the suspension for your load, and check the condition and pressure of your tires. NEVER OVERLOAD YOUR MOTORCYCLE. Make sure the total weight of the cargo, rider, passenger, and accessories (cowling, saddlebags, etc. if approved for this model) does not exceed the maximum load of the motorcycle. Operation of an overloaded motorcycle could cause tire damage, an accident, or even injury.

PERIODIC MAINTENANCE AND MINOR REPAIR

EAU00684

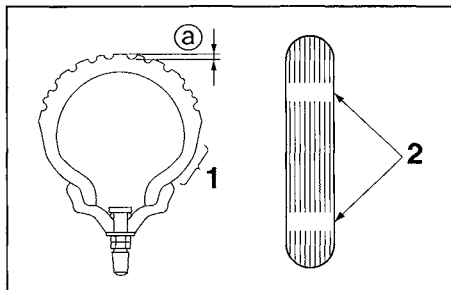

1. Sidewall
2. Wear indicator
- a. Tire tread depth

Tire inspection

Always check the tires before operating the motorcycle. If a tire tread shows crosswise lines (minimum tread depth), if the tire has a nail or glass fragments in it, or if the side wall is cracked, contact a Yamaha dealer immediately and have the tire replaced.

FRONT

Manufacturer	Size	Type
Bridgestone	110/90-18 61V	G525AW
Dunlop	110/90-18 61V	F20

REAR

Manufacturer	Size	Type
Bridgestone	150/90-15 M/C 74V	G526BW
Dunlop	150/90-15 M/C 74V	K525

Minimum tire tread depth (front and rear)	1.0 mm (0.04 in)
---	------------------

⚠ WARNING

This motorcycle is fitted with super-high-speed tires. Note the following points in order to make the most efficient use of these tires.

- Use only the specified replacement tires. Other tires may run the danger of bursting at super high speeds.
- Brand-new tires can have a relatively poor grip on certain road surfaces until they have been “broken in”. Therefore, it is advisable before doing any high-speed riding to ride conservatively for approximately 100 km (60 mi) after installing a new tire.
- The tires must be warmed up before a high-speed run.
- Always adjust the tire air pressure according to the operating conditions.

PERIODIC MAINTENANCE AND MINOR REPAIR

EAU00689

Cast wheels

To maximize the performance, durability, and safe operation of your motorcycle, note the following points regarding the specified wheels.

- The wheel rims should be checked for cracks, bends, warpage or damage before each ride. If any damage is found, have a Yamaha dealer replace the wheel. Do not attempt even the smallest repair to the wheel. A deformed or cracked wheel must be replaced.
- The wheel should be balanced whenever either the tire or wheel has been changed or replaced. An unbalanced wheel can result in poor performance, adverse handling characteristics, and a shortened tire life.
- Ride at moderate speeds after changing a tire since the tire surface must first be “broken in” for it to develop its optimal characteristics.

- After repairing or replacing a tire, tighten the valve stem nut and locknut to the specified torques.

Tightening torques:

Valve stem nut:

1.6 Nm (0.16 m·kg, 1.2 ft·lb)

Valve stem locknut:

1.6 Nm (0.16 m·kg, 1.2 ft·lb)

EAU00691

Accessories and replacement parts

EW000098

WARNING

This motorcycle is not designed to pull a trailer or to be attached to a sidecar. The accessories or replacement parts you choose for your motorcycle should be designed specifically for this model, and they must be securely mounted to maintain the inherent stability of the original design. Genuine Yamaha Parts and Accessories are designed and tested to be compatible with your motorcycle. Please consider Genuine Yamaha Parts and Accessories before making a purchase. Use of non-Yamaha-approved accessories or replacement parts may cause loss of handling stability and riding safety. Since Yamaha cannot control the quality of accessories or parts manufactured by other companies, Yamaha cannot be held lia-

PERIODIC MAINTENANCE AND MINOR REPAIR

ble for any consequences caused by the use of items which have not been approved by Yamaha.

EAU00695

Clutch lever free play

Since this model is equipped with a hydraulic clutch, adjusting the clutch lever free play is not needed. However, it is necessary to check the clutch fluid level and check the hydraulic system for leakage before each ride. If the clutch lever free play does become excessive, and shifting becomes rough or clutch slippage occurs, causing poor acceleration, there may be air in the clutch system. If there is air in the hydraulic system, have a Yamaha dealer bleed the system before operating the motorcycle.

PERIODIC MAINTENANCE AND MINOR REPAIR

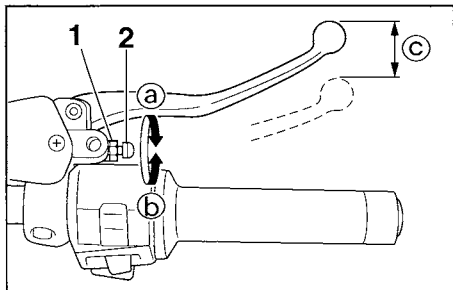

1. Locknut
2. Adjusting bolt
- c. Brake lever free play

EAU00696

Adjusting the brake lever free play

The brake lever free play should measure 2–5 mm (0.08–0.20 in) as shown. Periodically check the brake lever free play and, if necessary, adjust it as follows.

1. Loosen the locknut at the brake lever.
2. To increase the brake lever free play, turn the adjusting bolt in direction (a). To decrease the brake lever free play, turn the adjusting bolt in direction (b).

3. Tighten the locknut.

EW000099

WARNING

- After adjusting the brake lever free play, check the free play and make sure that the brake is working properly.
- A soft or spongy feeling in the brake lever can indicate the presence of air in the hydraulic system. If there is air in the hydraulic system, have a Yamaha dealer bleed the system before operating the motorcycle. Air in the hydraulic system will diminish the braking performance, which may result in loss of control and an accident.

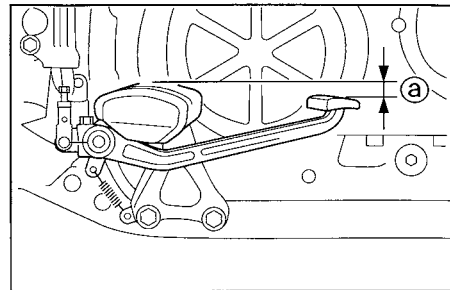

- a. Distance between brake pedal and footrest

EAU00712

Adjusting the brake pedal position

The top of the brake pedal should be positioned approximately 20 mm (0.8 in) below the top of the footrest as shown. Periodically check the brake pedal position and, if necessary, have a Yamaha dealer adjust it.

EW000109

⚠ WARNING

A soft or spongy feeling in the brake pedal can indicate the presence of air in the hydraulic system. If there is air in the hydraulic system, have a Yamaha dealer bleed the system before operating the motorcycle. Air in the hydraulic system will diminish the braking performance, which may result in loss of control and an accident.

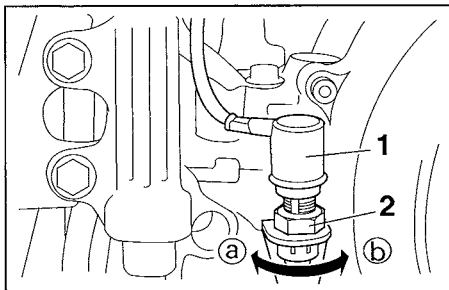

1. Brake light switch
2. Adjusting nut

EAU00713

Adjusting the rear brake light switch

The rear brake light switch, which is activated by the brake pedal, is properly adjusted when the brake light comes on just before braking takes effect. If necessary, adjust the brake light switch as follows.

Turn the adjusting nut while holding the rear brake light switch in place. To make the brake light come on earlier, turn the adjusting nut in direction Ⓐ. To make the brake light come on later, turn the adjusting nut in direction Ⓑ.

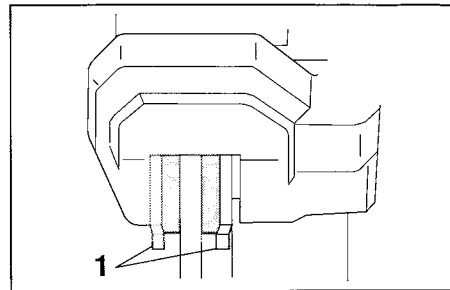

1. Wear indicator (× 2)

EAU00715

Checking the front and rear brake pads

The front and rear brake pads must be checked for wear at the intervals specified in the periodic maintenance and lubrication chart. Each brake pad is provided with a wear indicator, which allows you to check the brake pad wear without having to disassemble the brake. To check the brake pad wear, check the position of the wear indicator while applying the brake. If a brake pad has worn to the point that the wear indicator almost touches the brake disc, have a Yamaha dealer replace the brake pads as a set.

PERIODIC MAINTENANCE AND MINOR REPAIR

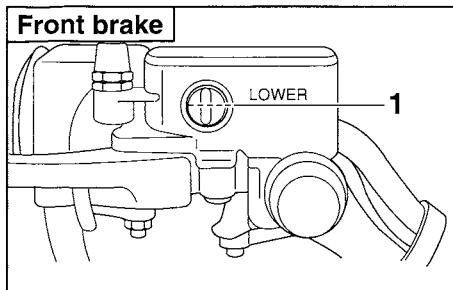

1. Minimum level mark

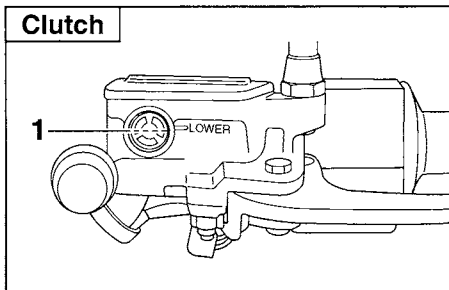

1. Minimum level mark

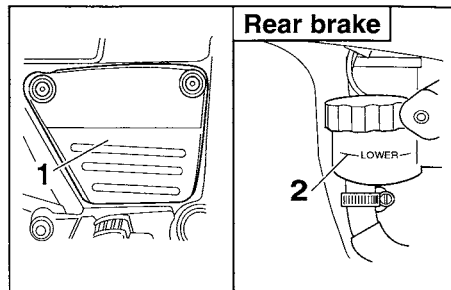

1. Panel B
2. Minimum level mark

Checking the brake fluid level

EAU03418

Insufficient brake fluid may allow air to enter the brake or clutch systems, possibly causing them to become ineffective.

Before riding, check that the brake fluid is above the minimum level mark and replenish if necessary. A low brake fluid level may indicate worn brake pads and/or brake system leakage. If the brake level is low, be sure to check the brake pads for wear and the brake system for leakage.

NOTE:

To check the rear brake fluid level, remove panel B. (See page 6-9 for panel removal and installation procedures.)

Observe these precautions:

- When checking the fluid level, make sure that the top of the master cylinder is level by turning the handlebars.
- Use only the recommended quality brake fluid, otherwise the rubber seals may deteriorate, causing leakage and poor braking or clutch performance.

Recommended brake fluid: DOT 4

- Refill with the same type of brake fluid. Mixing fluids may result in a harmful chemical reaction and lead to poor braking or clutch performance.
- The diaphragm will lose its shape from the negative pressure if the brake fluid level goes down too far. Be sure to put the diaphragm back in its original shape before installing it into the master cylinder.
- Be careful that water does not enter the master cylinder when refilling. Water will significantly lower the boiling point of the fluid and may result in vapor lock.

PERIODIC MAINTENANCE AND MINOR REPAIR

- Brake fluid may deteriorate painted surfaces or plastic parts. Always clean up spilled fluid immediately.
- As the brake pads wear, it is normal for the brake fluid level to gradually go down. However, if the brake fluid level goes down suddenly, have a Yamaha dealer check the cause.

EAU03238

Changing the brake fluid

Have a Yamaha dealer change the brake fluid at the intervals specified in the periodic maintenance and lubrication chart. In addition, have the oil seals of the brake master cylinder and caliper as well as the brake hose replaced at the intervals listed below or whenever they are damaged or leaking.

- Oil seals: Replace every two years.
- Brake hose: Replace every four years.

EAU03297

Checking and lubricating the cables

The operation of all control cables and the condition of the cables should be checked before each ride, and the cables and cable ends should be lubricated if necessary. If a cable is damaged or does not move smoothly, have a Yamaha dealer check or replace it.

Recommended lubricant:

Yamaha Chain and Cable Lube
or engine oil SAE 10W-30
(API SE)

EW000111

WARNING

Damage to the outer housing of cables may result in internal rusting and cause interference with cable movement. Replace damaged cables as soon as possible to prevent unsafe conditions.

PERIODIC MAINTENANCE AND MINOR REPAIR

EAU03364

Checking and lubricating the throttle grip and cable

The operation of the throttle grip and the condition of the throttle cable should be checked before each ride, and the cable should be lubricated or replaced if necessary.

NOTE:

Since the throttle grip must be removed to access the throttle cable end, the throttle grip and the cable should always be lubricated at the same time.

1. Remove the throttle grip by removing the screws.
2. Disconnect the throttle cable, hold it up, and then apply several drops of oil to the cable end, allowing it to trickle into the sheath.
3. Connect the throttle cable, and then grease the inside of the throttle grip housing.
4. Grease the metal-to-metal contact surface of the throttle grip, and then install the grip by installing the screws.

Recommended lubricant:

Throttle cable:

Yamaha Chain and Cable
Lube or engine oil
SAE 10W-30

Throttle grip housing and grip:

Lithium-soap-based grease
(all-purpose grease)

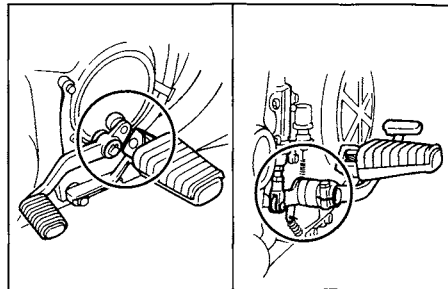

EAU03370

Checking and lubricating the brake and shift pedals

The operation of the brake and shift pedals should be checked before each ride, and the pedal pivots should be lubricated if necessary.

Recommended lubricant:

Lithium-soap-based grease
(all-purpose grease)

PERIODIC MAINTENANCE AND MINOR REPAIR

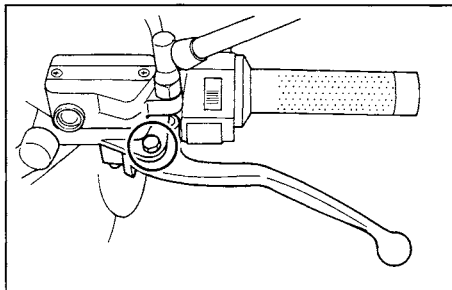

EAU03164

Checking and lubricating the brake and clutch levers

The operation of the brake and clutch levers should be checked before each ride, and the lever pivots should be lubricated if necessary.

Recommended lubricant:
Lithium-soap-based grease
(all-purpose grease)

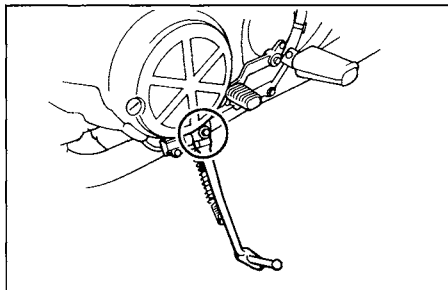

EAU03371

Checking and lubricating the centerstand and sidestand

The operation of the centerstand and sidestand should be checked before each ride, and the pivots and metal-to-metal contact surfaces should be lubricated if necessary.

EW000114

! WARNING

If the centerstand or sidestand does not move up and down smoothly, have a Yamaha dealer check or repair it.

Recommended lubricant:
Lithium-soap-based grease
(all-purpose grease)

PERIODIC MAINTENANCE AND MINOR REPAIR

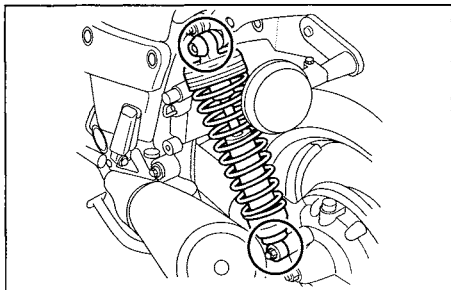

EAU03166

Lubricating the rear suspension

The pivoting points of the rear suspension must be lubricated at the intervals specified in the periodic maintenance and lubrication chart.

Recommended lubricant:
Lithium-soap-based grease
(all-purpose grease)

EAU02939

Checking the front fork

The condition and operation of the front fork must be checked as follows at the intervals specified in the periodic maintenance and lubrication chart.

To check the condition

EW000115

! WARNING

Securely support the motorcycle so that there is no danger of it falling over.

Check the inner tubes for scratches, damage and excessive oil leakage.

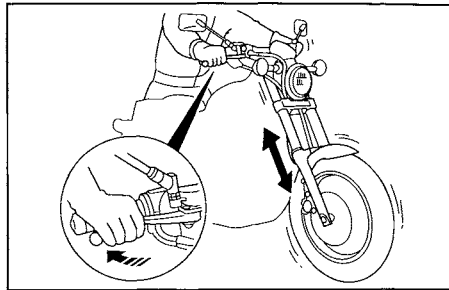

To check the operation

1. Place the motorcycle on a level surface and hold it in an upright position.
2. While applying the front brake, push down hard on the handlebars several times to check if the front fork compresses and rebounds smoothly.

EC000098

CAUTION:

If any damage is found or the front fork does not operate smoothly, have a Yamaha dealer check or repair it.

EAU00794

Checking the steering

Worn or loose steering bearings may cause danger. Therefore, the operation of the steering must be checked as follows at the intervals specified in the periodic maintenance and lubrication chart.

1. Place a stand under the engine to raise the front wheel off the ground.

EW000115

! WARNING

Securely support the motorcycle so that there is no danger of it falling over.

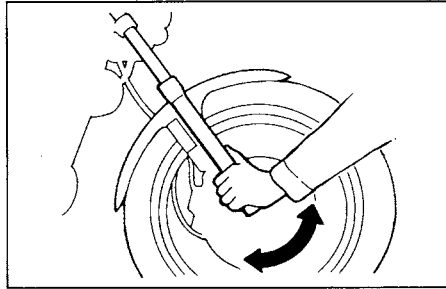

2. Hold the lower ends of the front fork legs and try to move them forward and backward. If any free play can be felt, have a Yamaha dealer check or repair the steering.

PERIODIC MAINTENANCE AND MINOR REPAIR

Checking the wheel bearings

EAU01144

The front and rear wheel bearings must be checked at the intervals specified in the periodic maintenance and lubrication chart. If there is play in the wheel hub or if the wheel does not turn smoothly, have a Yamaha dealer check the wheel bearings.

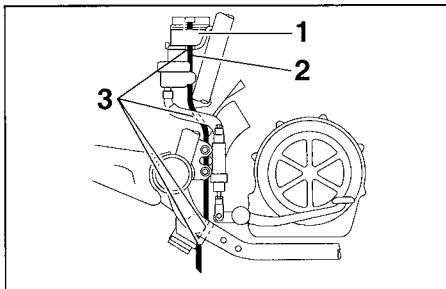

1. Battery
2. Battery breather hose
3. Pass through the cable guide.

Battery

EAU03401

A poorly maintained battery will corrode and discharge quickly. The electrolyte level, battery lead connections and breather hose routing should be checked before each ride and at the intervals specified in the periodic maintenance and lubrication chart.

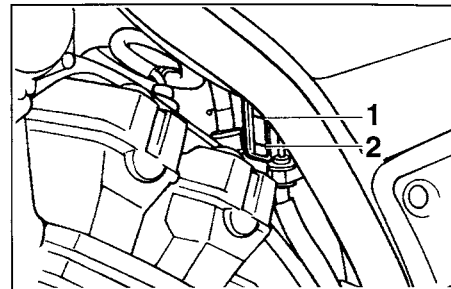

1. Maximum level mark
2. Minimum level mark

To check the electrolyte level

1. Place the motorcycle on a level surface and hold it in an upright position.

NOTE: _____
Make sure that the motorcycle is positioned straight up when checking the electrolyte level.

2. Check the electrolyte level in the battery.

NOTE: _____
The electrolyte should be between the minimum and maximum level marks.

PERIODIC MAINTENANCE AND MINOR REPAIR

3. If the electrolyte is at or below the minimum level mark, continue with the following steps.

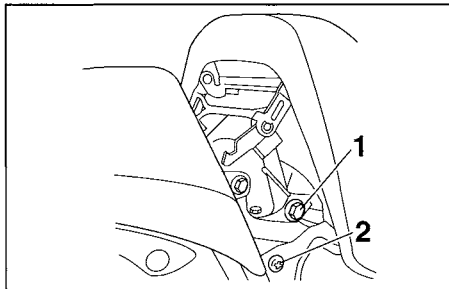

1. Bolt (× 2)
2. Screw (× 2)

4. Remove the rider seat. (See page 3-9 for rider seat removal and installation procedures.)
5. Disconnect the negative battery lead from the battery.

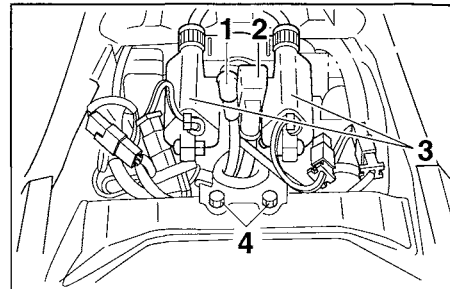

1. Starter motor lead (black)
2. Battery positive lead (red)
3. Ignition coil assembly (× 2)
4. Bolt (× 2)

6. Disconnect the positive battery lead and the starter motor lead from the starter motor relay.
7. Remove the ignition coil assemblies by removing the bolts.
8. Add distilled water to raise the electrolyte to the maximum level mark.

PERIODIC MAINTENANCE AND MINOR REPAIR

EW000116

! WARNING

- Electrolyte is poisonous and dangerous since it contains sulfuric acid, which causes severe burns. Avoid any contact with skin, eyes or clothing and always shield your eyes when working near batteries. In case of contact, administer the following FIRST AID.
 - EXTERNAL: Flush with plenty of water.
 - INTERNAL: Drink large quantities of water or milk and immediately call a physician.
 - EYES: Flush with water for 15 minutes and seek prompt medical attention.
- Batteries produce explosive hydrogen gas. Therefore, keep sparks, flames, cigarettes, etc., away from the battery and provide sufficient ventilation when charging it in an enclosed space.

- KEEP THIS AND ALL BATTERIES OUT OF THE REACH OF CHILDREN.

EC000100

CAUTION:

Use only distilled water, as tap water contains minerals that are harmful to the battery.

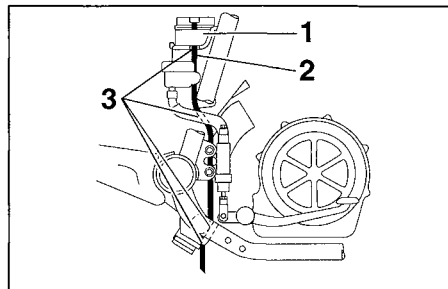

1. Battery
2. Battery breather hose
3. Pass through the cable guide.
9. Check and, if necessary, correct the breather hose routing.
10. Install the ignition coil assemblies by installing the bolts.

PERIODIC MAINTENANCE AND MINOR REPAIR

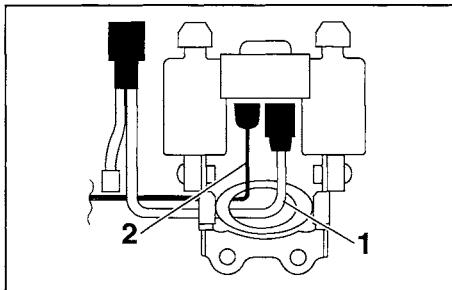

1. Battery positive lead (red)
2. Starter motor lead (black)

11. Connect and tighten the positive battery lead and the starter motor lead to the starter motor relay.

EW000118

⚠ WARNING

Pass the positive battery lead and starter lead through the hole in the ignition coil bracket as shown. Improper routing of these leads could bring about a short circuit, causing the engine and lights to fail and possibly resulting in an accident.

12. Connect and tighten the negative battery lead to the battery.
13. Install the rider seat.

To store the battery

1. If the motorcycle will not be used for more than one month, remove the battery, fully charge it, and then place it in a cool, dry place.
2. If the battery will be stored for more than two months, check the specific gravity of the electrolyte at least once a month and fully charge the battery whenever necessary.
3. Fully charge the battery before installation.

4. After installation, make sure that the battery leads are properly connected to the battery terminals and that the breather hose is properly routed, in good condition, and not obstructed.

EC000099

CAUTION:

If the breather hose is positioned in such a way that the frame is exposed to electrolyte or gas expelled from the battery, the frame could suffer structural and external damages.

PERIODIC MAINTENANCE AND MINOR REPAIR

EC000103

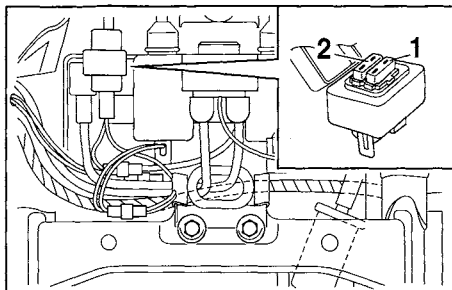

1. Main fuse
2. Spare main fuse

EAU01664

Replacing the fuses

The main fuse box is located under the rider seat. (See page 3-9 for rider seat removal and installation procedures.)

The fuse box, which contains the fuses for the individual circuits, is located under cowling A. (See page 6-8 for cowling removal and installation procedures.)

If a fuse is blown, replace it as follows.

1. Turn the key to "OFF" and turn off the electrical circuit in question.
2. Remove the blown fuse, and then install a new fuse of the specified amperage.

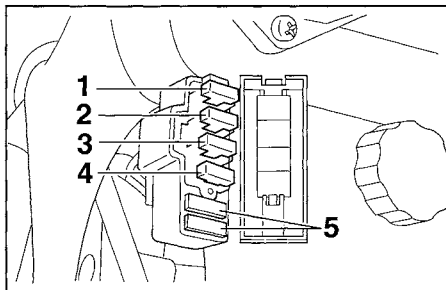

1. Headlight fuse
2. Signaling system fuse
3. Ignition fuse
4. Radiator fan fuse
5. Spare fuse (x 2)

Specified fuses:

Main fuse:	30 A
Headlight fuse:	15 A
Signaling system fuse:	10 A
Radiator fan fuse:	10 A
Ignition fuse:	10 A

CAUTION:

Do not use a fuse of a higher amperage rating than recommended to avoid causing extensive damage to the electrical system and possibly a fire.

3. Turn the key to "ON" and turn on the electrical circuit in question to check if the device operates.
4. If the fuse immediately blows again, have a Yamaha dealer check the electrical system.

PERIODIC MAINTENANCE AND MINOR REPAIR

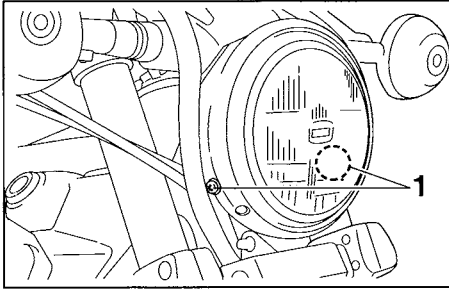

1. Screw (× 2)

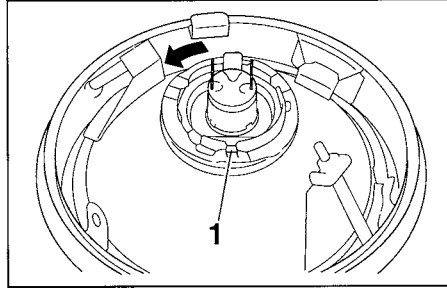

1. Headlight bulb holder

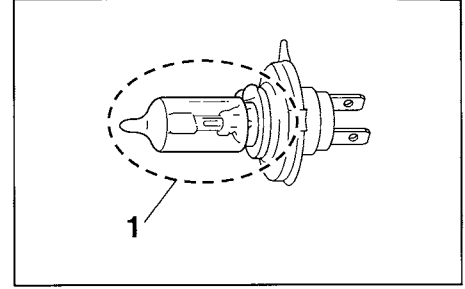

1. Do not touch this area.

Replacing the headlight bulb

EAU03003

This motorcycle is equipped with a quartz bulb headlight. If the headlight bulb burns out, replace it as follows.

1. Remove the headlight unit by removing the screws.
2. Disconnect the headlight coupler, and then remove the headlight unit and bulb cover.

3. Remove the headlight bulb holder by turning it counterclockwise, and then remove the defective bulb.

EW000119

WARNING

Headlight bulbs get very hot. Therefore, keep flammable products away from a lit headlight bulb, and do not touch the bulb until it has cooled down.

4. Place a new bulb into position, and then secure it with the bulb holder.

CAUTION:

Do not touch the glass part of the headlight bulb to keep it free from oil, otherwise the transparency of the glass, the luminosity of the bulb, and the bulb life will be adversely affected. Thoroughly clean off any dirt and fingerprints on the headlight bulb using a cloth moistened with alcohol or thinner.

5. Install the bulb cover, and then connect the coupler.
6. Install the headlight unit by installing the screws.
7. Have a Yamaha dealer adjust the headlight beam if necessary.

PERIODIC MAINTENANCE AND MINOR REPAIR

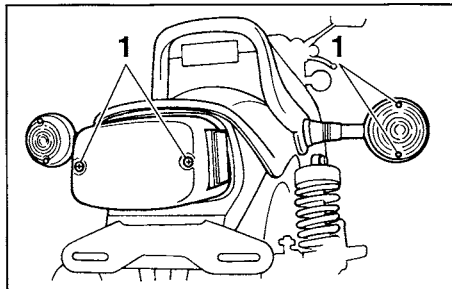

1. Screw (× 2)

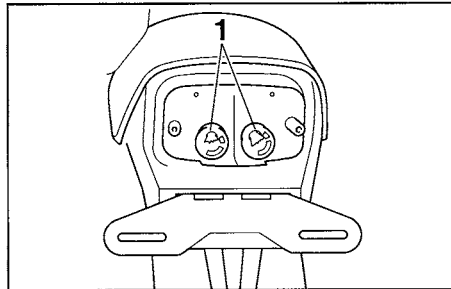

1. Tail/brake light bulb (× 2)

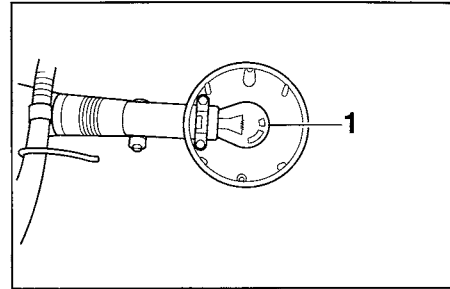

1. Turn signal light bulb

Replacing a turn signal light bulb or the tail/brake light bulb

EAU00855

1. Remove the lens by removing the screws.
2. Remove the defective bulb by pushing it in and turning it counter-clockwise.

3. Insert a new bulb into the socket, push it in, and then turn it clockwise until it stops.

4. Install the lens by installing the screws.

EC000108

CAUTION:

Do not overtighten the screws, otherwise the lens may break.

PERIODIC MAINTENANCE AND MINOR REPAIR

Front wheel

EAU03419

To remove the front wheel

EW000122

⚠ WARNING

- It is advisable to have a Yamaha dealer service the wheel.
- Securely support the motorcycle so that there is no danger of it falling over.

1. Place the motorcycle on the centerstand.

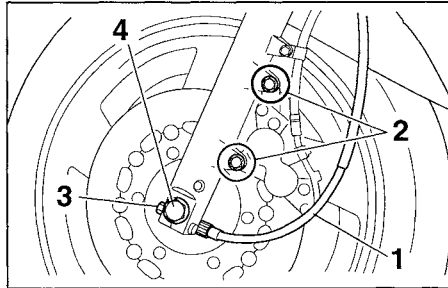

1. Speedometer cable
2. Bolt (× 2)
3. Pinch bolt
4. Wheel axle

2. Disconnect the speedometer cable from the front wheel.
3. Remove the brake caliper by removing the bolts.

ECA00047

CAUTION:

Do not pull the brake lever after the brake caliper has been removed, otherwise the brake pads will be forced shut.

4. Loosen the front wheel axle pinch bolt, then the wheel axle.
5. Pull the wheel axle out, and then remove the wheel.

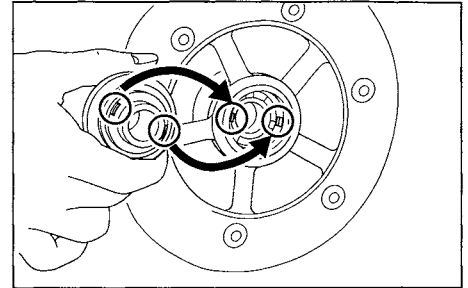

EAU03420

To install the front wheel

1. Install the speedometer gear unit into the wheel hub so that the projections mesh with the slots.

PERIODIC MAINTENANCE AND MINOR REPAIR

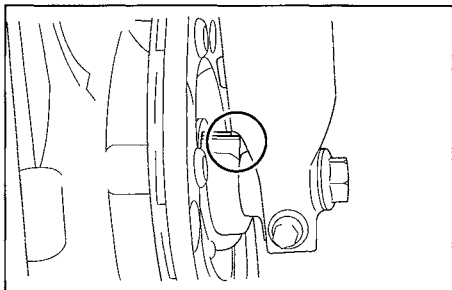

2. Lift the wheel up between the fork legs.

NOTE:
Make sure that the slot in the speedometer gear unit fits over the retainer on the fork leg.

3. Insert the wheel axle.
4. Take the motorcycle off the centerstand so that the front wheel is on the ground.
5. Install the brake calipers by installing the bolts.

NOTE:
Make sure that there is enough space between the brake pads before installing the brake calipers onto the brake discs.

6. Tighten the front wheel axle pinch bolt, then the wheel axle, and the brake caliper bolts to the specified torques.

Tightening torques:

Wheel axle:

58 Nm (5.8 m·kg, 42 ft·lb)

Front wheel axle pinch bolt:

20 Nm (2.0 m·kg, 14 ft·lb)

Brake caliper bolt:

40 Nm (4.0 m·kg, 29 ft·lb)

7. Connect the speedometer cable.
8. Push down hard on the handlebar several times to check for proper fork operation.

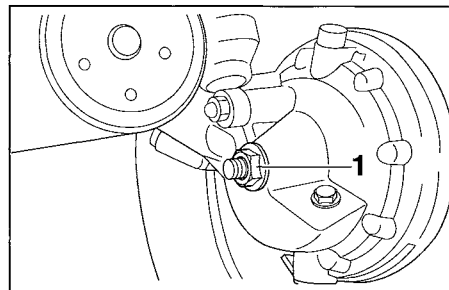

1. Axle nut

EAU03421

Rear wheel

To remove the rear wheel

EW000122

WARNING

- It is advisable to have a Yamaha dealer service the wheel.
- Securely support the motorcycle so that there is no danger of it falling over.

PERIODIC MAINTENANCE AND MINOR REPAIR

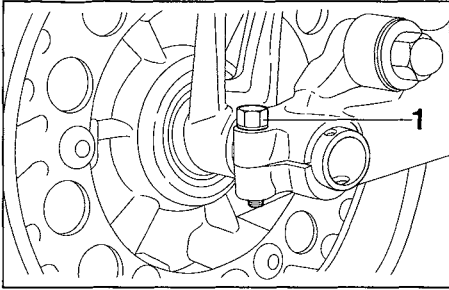

1. Pinch bolt

1. Loosen the rear wheel axle pinch bolt, then the axle nut.
2. Place the motorcycle on the centerstand.

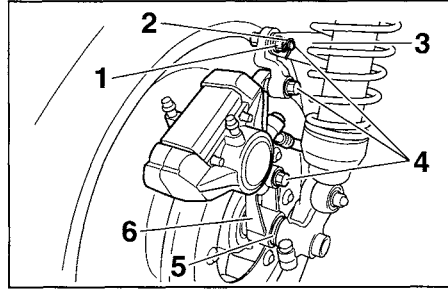

1. Nut

2. Cotter pin
 3. Brake torque rod
 4. Bolt (× 3)
 5. Brake caliper bracket
 6. Spacer
3. Remove the brake caliper bolts and the axle nut.
 4. Disconnect the brake torque rod from the brake caliper bracket by removing the cotter pin, the nut, and the bolt.

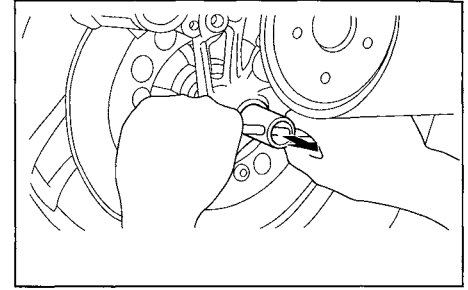

5. While supporting the brake caliper, pull the wheel axle out.
6. Remove the brake caliper bracket and spacer.
7. Pull the wheel to the right to separate it from the final gear case, and then remove it.

ECA00062

CAUTION:

Do not push the brake pedal after the wheel has been removed together with the brake disc, otherwise the brake pads will be forced shut.

PERIODIC MAINTENANCE AND MINOR REPAIR

EAU03087

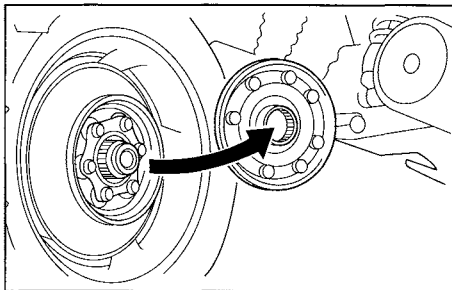

EAU03422

To install the rear wheel

1. Apply a light coating of lithium-soap-based grease to the splines of the final gear case and wheel hub.
2. Install the wheel, brake caliper bracket, spacer and wheel axle.
3. Install the brake caliper by installing the bolts.

NOTE: Make sure that there is enough space between the brake pads before installing the brake caliper onto the brake disc.

4. Install the brake torque rod bolt and nut at the brake caliper bracket.
5. Install the rear wheel axle nut.
6. Take the motorcycle off the centerstand so that the rear wheel is on the ground.
7. Tighten the axle nut, brake caliper bolts, brake torque rod nut, and pinch bolt to the specified torques.

Tightening torques:

Axle nut:

150 Nm (15.0 m·kg, 108 ft·lb)

Brake caliper bolt:

40 Nm (4.0 m·kg, 29 ft·lb)

Brake torque rod nut:

48 Nm (4.8 m·kg, 35 ft·lb)

Rear wheel axle pinch bolt:

16 Nm (1.6 m·kg, 11 ft·lb)

8. Install the brake torque rod cotter pin.

EW000124



WARNING

Always use a new cotter pin.

Troubleshooting

Although Yamaha motorcycles receive a thorough inspection before shipment from the factory, trouble may occur during operation. Any problem in the fuel, compression, or ignition systems, for example, can cause poor starting and loss of power.

The following troubleshooting charts represent quick and easy procedures for checking these vital systems yourself. However, should your motorcycle require any repair, take it to a Yamaha dealer, whose skilled technicians have the necessary tools, experience, and know-how to service the motorcycle properly.

Use only genuine Yamaha replacement parts. Imitation parts may look like Yamaha parts, but they are often inferior, have a shorter service life and can lead to expensive repair bills.

PERIODIC MAINTENANCE AND MINOR REPAIR

EAU03363

Troubleshooting charts

Starting problems or poor engine performance

EW000125



WARNING

Keep away open flames and do not smoke while checking or working on the fuel system.

1. Fuel

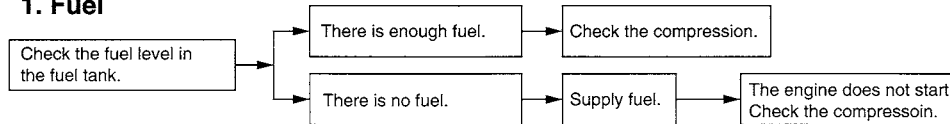

2. Compression

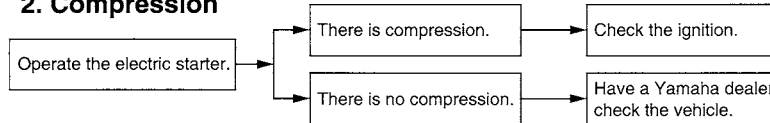

3. Ignition

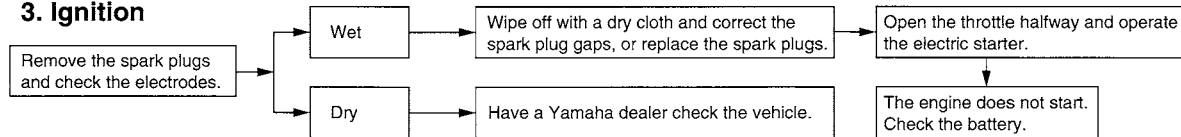

4. Battery

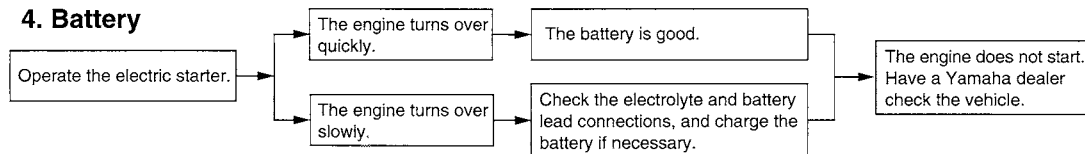

PERIODIC MAINTENANCE AND MINOR REPAIR

Engine overheating

EW000070

⚠ WARNING

- Do not remove the radiator cap when the engine and radiator are hot. Scalding hot fluid and steam may be blown out under pressure, which could cause serious injury. Be sure to wait until the engine has cooled.
- After removing the radiator cap retaining bolt, place a thick rag, like a towel, over the radiator cap, and then slowly rotate the cap counterclockwise to the detent to allow any residual pressure to escape. When the hissing sound has stopped, press down on the cap while turning it counterclockwise, and then remove the cap.

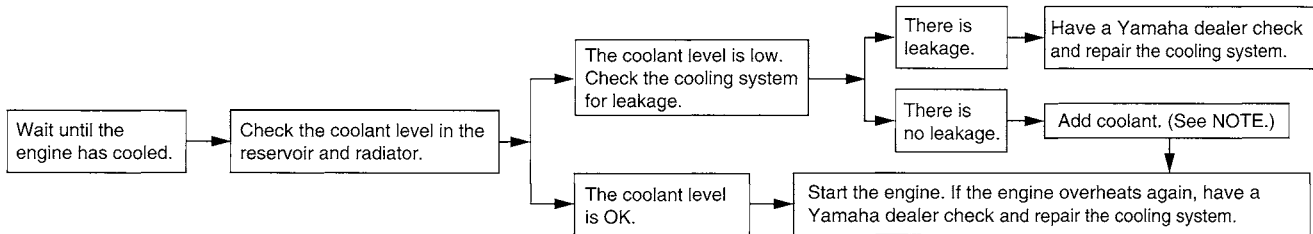

NOTE: If coolant is not available, tap water can be temporarily used instead, provided that it is changed to the recommended coolant as soon as possible.

MOTORCYCLE CARE AND STORAGE

Care	7-1
Storage	7-4

Care

While the open design of a motorcycle reveals the attractiveness of the technology, it also makes it more vulnerable. Rust and corrosion can develop even if high-quality components are used. A rusty exhaust pipe may go unnoticed on a car, however, it detracts from the overall appearance of a motorcycle. Frequent and proper care does not only comply with the terms of the warranty, but it will also keep your motorcycle looking good, extend its life and optimize its performance.

Before cleaning

1. Cover the muffler outlets with plastic bags after the engine has cooled down.
2. Make sure that all caps and covers as well as all electrical couplers and connectors, including the spark plug caps, are tightly installed.
3. Remove extremely stubborn dirt, like oil burnt onto the crankcase, with a degreasing agent and a brush, but never apply such products onto seals, gaskets and wheel axles. Always rinse the dirt and degreaser off with water.

Cleaning

ECA00010

CAUTION:

- **Avoid using strong acidic wheel cleaners, especially on spoked wheels. If such products are used on hard-to-remove dirt, do not leave the cleaner on the affected area any longer than instructed. Also, thoroughly rinse the area off with water, immediately dry it, and then apply a corrosion protection spray.**
- **Improper cleaning can damage windshields, cowlings, panels and other plastic parts. Use only a soft, clean cloth or sponge with mild detergent and water to clean plastic.**

MOTORCYCLE CARE AND STORAGE

- Do not use any harsh chemical products on plastic parts. Be sure to avoid using cloths or sponges which have been in contact with strong or abrasive cleaning products, solvent or thinner, fuel (gasoline), rust removers or inhibitors, brake fluid, antifreeze or electrolyte.
- Do not use high-pressure washers or steam-jet cleaners since they cause water seepage and deterioration in the following areas: seals (of wheel and swing-arm bearings, fork and brakes), electric components (couplers, connectors, instruments, switches and lights), breather hoses and vents.

- For motorcycles equipped with a windshield: Do not use strong cleaners or hard sponges as they will cause dulling or scratching. Some cleaning compounds for plastic may leave scratches on the windshield. Test the product on a small hidden part of the windshield to make sure that it does not leave any marks. If the windshield is scratched, use a quality plastic polishing compound after washing.

After normal use

Remove dirt with warm water, a mild detergent, and a soft, clean sponge, and then rinse thoroughly with clean water. Use a toothbrush or bottlebrush for hard-to-reach areas. Stubborn dirt and insects will come off more easily if the area is covered with a wet cloth for a few minutes before cleaning.

After riding in the rain, near the sea or on salt-sprayed roads

Since sea salt or salt sprayed on roads during winter are extremely corrosive in combination with water, carry out the following steps after each ride in the rain, near the sea or on salt-sprayed roads.

NOTE:

Salt sprayed on roads in the winter may remain well into spring.

1. Clean the motorcycle with cold water and a mild detergent, after the engine has cooled down.

ECA00012

CAUTION:

Do not use warm water since it increases the corrosive action of the salt.

2. After drying the motorcycle, apply a corrosion protection spray on all metal, including chrome- and nickel-plated, surfaces to prevent corrosion.

MOTORCYCLE CARE AND STORAGE

After cleaning

1. Dry the motorcycle with a chamois or an absorbing cloth.
2. Use a chrome polish to shine chrome, aluminum and stainless-steel parts, including the exhaust system. (Even the thermally induced discoloring of stainless-steel exhaust systems can be removed through polishing.)
3. To prevent corrosion, it is recommended to apply a corrosion protection spray on all metal, including chrome- and nickel-plated, surfaces.
4. Use spray oil as a universal cleaner to remove any remaining dirt.
5. Touch up minor paint damage caused by stones, etc.
6. Wax all painted surfaces.
7. Let the motorcycle dry completely before storing or covering it.

EWA00031

WARNING

- Make sure that there is no oil or wax on the brakes or tires.
 - If necessary, clean the brake discs and brake linings with a regular brake disc cleaner or acetone, and wash the tires with warm water and a mild detergent. Before riding at higher speeds, test the motorcycle's braking performance and cornering behavior.
-

ECA00013

CAUTION:

- Apply spray oil and wax sparingly and make sure to wipe off any excess.
 - Never apply oil or wax to any rubber and plastic parts, but treat them with a suitable care product.
 - Avoid using abrasive polishing compounds as they will wear away the paint.
-

NOTE:

Consult a Yamaha dealer for advice on what products to use.

Storage

Short-term

Always store your motorcycle in a cool, dry place and, if necessary, protect it against dust with a porous cover.

ECA00014

CAUTION:

- **Storing the motorcycle in a poorly ventilated room or covering it with a tarp, while it is still wet, will allow water and humidity to seep in and cause rust.**
- **To prevent corrosion, avoid damp cellars, stables (because of the presence of ammonia) and areas where strong chemicals are stored.**

Long-term

Before storing your motorcycle for several months:

1. Follow all the instructions in the “Care” section of this chapter.
2. For motorcycles equipped with a fuel cock that has an “OFF” position: Turn the fuel cock lever to “OFF”.
3. Drain the carburetor float chambers by loosening the drain bolts; this will prevent fuel deposits from building up. Pour the drained fuel into the fuel tank.
4. Fill up the fuel tank and add fuel stabilizer (if available) to prevent the fuel tank from rusting and the fuel from deteriorating.
5. Perform the following steps to protect the cylinders, piston rings, etc. from corrosion.

- a. Remove the spark plug caps and spark plugs.
- b. Pour a teaspoonful of engine oil into each spark plug bore.
- c. Install the spark plug caps onto the spark plugs, and then place the spark plugs on the cylinder head so that the electrodes are grounded. (This will limit sparking during the next step.)
- d. Turn the engine over several times with the starter. (This will coat the cylinder walls with oil.)
- e. Remove the spark plug caps from the spark plugs, and then install the spark plugs and the spark plug caps.

EWA00003

WARNING

To prevent damage or injury from sparking, make sure to ground the spark plug electrodes while turning the engine over.

MOTORCYCLE CARE AND STORAGE

6. Lubricate all control cables and the pivoting points of all levers and pedals as well as of the sidestand/centerstand.
7. Check and, if necessary, correct the tire air pressure, and then lift the motorcycle so that both of its wheels are off the ground. Alternatively, turn the wheels a little every month in order to prevent the tires from becoming degraded in one spot.
8. Cover the muffler outlets with plastic bags to prevent moisture from entering them.
9. Remove the battery and fully charge it. Store it in a cool, dry place and charge it once a month. Do not store the battery in an excessively cold or warm place [less than 0 °C (30 °F) or more than 30 °C (90 °F)]. For more information on storing the battery, see page 6-38.

NOTE: _____
Make any necessary repairs before storing the motorcycle.

Specifications 8-1

Specifications

Model	VMX12/VMX12C
Dimensions	
Overall length	2,300 mm (90.6 in)
Overall width	795 mm (31.3 in)
Overall height	1,160 mm (45.7 in)
Seat height	765 mm (30.1 in)
Wheelbase	1,590 mm (62.6 in)
Ground clearance	145 mm (5.7 in)
Minimum turning radius	2,900 mm (114.2 in)
Basic weight (with oil and full fuel tank)	
VMX12	283 kg (624 lb)
VMX12C	284 kg (626 lb)
Engine	
Engine type	Liquid-cooled 4-stroke, DOHC
Cylinder arrangement	V type, 4-cylinder
Displacement	1,198 cm ³
Bore × stroke	76 × 66 mm (3.0 × 2.6 in)
Compression ratio	10.5:1
Starting system	Electric starter
Lubrication system	Wet sump

Engine oil

Type

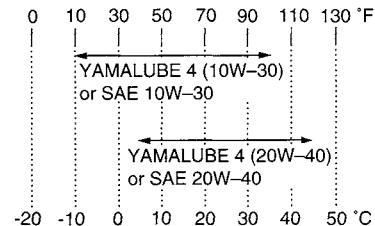

Recommended engine oil classification

API Service SE, SF, SG type or higher

CAUTION:

Be sure to use motor oils that do not contain anti-friction modifiers. Passenger car motor oils (often labeled "Energy Conserving") contain anti-friction additives which will cause clutch and/or starter clutch slippage, resulting in reduced component life and poor engine performance.

Quantity

Without oil filter cartridge replacement	3.2 L (2.8 Imp qt, 3.4 US qt)
With oil filter cartridge replacement	3.4 L (3.0 Imp qt, 3.6 US qt)
Total amount (dry engine)	4.0 L (3.5 Imp qt, 4.2 US qt)

Final gear oil

Type	SAE80API "GL-4" Hypoid gear oil
Quantity	0.2 L (0.18 Imp qt, 0.21 US qt)

Cooling system capacity (total amount)

3.05 L (2.68 Imp qt, 3.22 US qt)

Air filter

Dry type element

Fuel

Type	Unleaded fuel
Fuel tank capacity	15 L (3.3 Imp gal, 4.0 US gal)
Fuel reserve amount	3 L (0.7 Imp gal, 0.8 US gal)

Carburetor

Manufacturer	MIKUNI
Model × quantity	BDS35 × 4

Spark plug

Manufacturer/model	DPR8EA-9 / NGK or X24EPR-U9 / DENSO
Gap	0.8–0.9 mm (0.03–0.04 in)

Clutch type

Wet, multiple-disc

Transmission

Primary reduction system	Spur gear
Primary reduction ratio	1.775
Secondary reduction system	Shaft drive
Secondary reduction ratio	2.851
Transmission type	Constant-mesh, 5-speed

Operation

Left foot

Gear ratio

1st	2.529
2nd	1.772
3rd	1.347
4th	1.076
5th	0.928

Chassis

Frame type	Double cradle
Caster angle	29°
Trail	119 mm (4.69 in)

Tires

Front

Type	Tubeless
Size	110/90-18 61V
Manufacturer/ model	Bridgestone / G525AW Dunlop / F20

Rear

Type	Tubeless
Size	150/90-15 M/C 74V
Manufacturer/ model	Bridgestone / G526BW Dunlop / K525

SPECIFICATIONS

Maximum load*

VMX12 216 kg (476 lb)

VMX12C 215 kg (474 lb)

Tire air pressure (measured on cold tires)

Up to 90 kg (198 lb)*

Front 225 kPa (2.25 kgf/cm², 33 psi)

Rear 225 kPa (2.25 kgf/cm², 33 psi)

90 kg (198 lb)—maximum*

Front 225 kPa (2.25 kgf/cm², 33 psi)

Rear 250 kPa (2.50 kgf/cm², 36 psi)

High-speed riding

Front 225 kPa (2.25 kgf/cm², 33 psi)

Rear 250 kPa (2.50 kgf/cm², 36 psi)

* Total weight of rider, passenger, cargo and accessories

Wheels

Front

Type Cast wheel

Size 18 × MT 2.15

Rear

Type Cast wheel

Size 15M/C × MT 3.50

Brakes

Front

Type Dual disc brake

Operation Right hand

Fluid DOT 4

Rear

Type Single disc brake

Operation Right foot

Fluid DOT 4

Suspension

Front Telescopic fork

Rear Swingarm

Spring/shock absorber

Front Coil-air spring / oil damper

Rear Coil spring / oil damper

Wheel travel

Front 140 mm (5.5 in)

Rear 100 mm (3.9 in)

Electrical system

Ignition system T.C.I. (digital)

Charging system

Type A.C. magneto

Standard output 14 V, 22.5 A @ 5,000 r/min

Battery

Model YB16AL-A2

Voltage, capacity 12 V, 16 Ah

Headlight type

Quartz bulb (halogen)

Bulb voltage, wattage × quantity

Headlight	12 V, 60/55 W × 1
Tail/brake light	12 V, 8/27 W × 2
Front turn signal/position light	12 V, 27/8 W × 2
Rear turn signal light	12 V, 27 W × 2
Meter lighting	14 V, 3 W × 2
Neutral indicator light	14 V, 3 W × 1
High beam indicator light	14 V, 3 W × 1
Turn signal indicator light	14 V, 3 W × 1
Fuel level warning light	14 V, 3 W × 1
Oil level warning light	14 V, 3 W × 1

Fuses

Main fuse	30 A
Headlight fuse	15 A
Signaling system fuse	10 A
Radiator fan fuse	10 A
Ignition fuse	10 A

CONSUMER INFORMATION

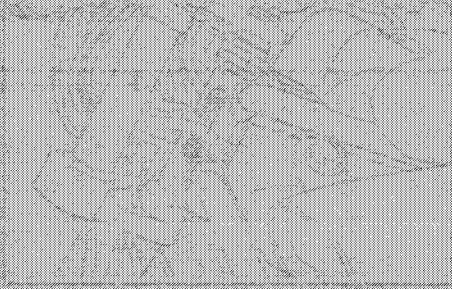

Identification numbers	9-1
Key identification number	9-1
Vehicle identification number	9-1
Model label	9-2
Reporting safety defects	9-3
Motorcycle noise regulation	9-4
Maintenance record	9-5
YAMAHA MOTOR CORPORATION, U.S.A. STREET AND ENDURO MOTORCYCLE LIMITED WARRANTY	9-7
YAMAHA EXTENDED SERVICE (Y.E.S.)	9-9

Identification numbers

EAU02944

Record the key identification number, vehicle identification number and model label information in the spaces provided below for assistance when ordering spare parts from a Yamaha dealer or for reference in case the vehicle is stolen.

1. KEY IDENTIFICATION NUMBER:

2. VEHICLE IDENTIFICATION NUMBER:

3. MODEL LABEL INFORMATION:

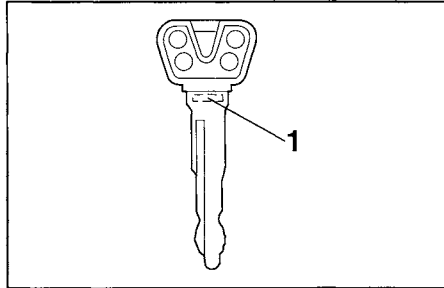

1. Key identification number

EAU01042

Key identification number

The key identification number is stamped into the key. Record this number in the space provided and use it for reference when ordering a new key.

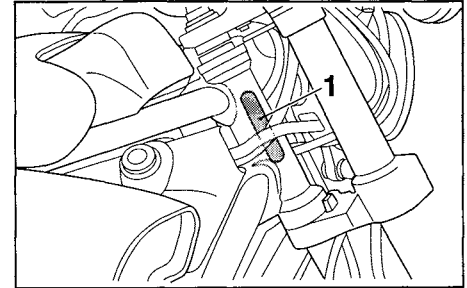

1. Vehicle identification number

EAU01043

Vehicle identification number

The vehicle identification number is stamped into the steering head pipe. Record this number in the space provided.

NOTE:

The vehicle identification number is used to identify your motorcycle and may be used to register your motorcycle with the licensing authority in your area.

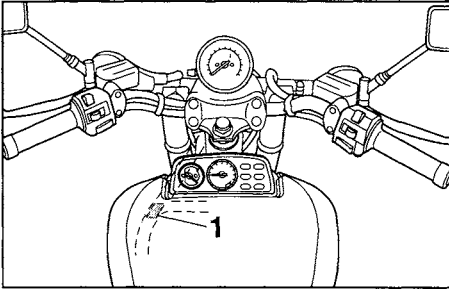

1. Model label

EAU03424

Model label

The model label is affixed under cowling A. (See page 6-8 for cowling removal and installation procedures.)

Record the information on this label in the space provided. This information will be needed when ordering spare parts from a Yamaha dealer.

CONSUMER INFORMATION

EAU01051

Reporting safety defects

If you believe that your vehicle has a defect which could cause a crash or could cause injury or death, you should immediately inform the National Highway Traffic Safety Administration (NHTSA) in addition to notifying Yamaha Motor Corporation, U.S.A. If NHTSA receives similar complaints, it may open an investigation, and if it finds that a safety defect exists in group of vehicles, it may order a recall and remedy campaign. However, NHTSA cannot become involved in individual problems between you, your dealer, or Yamaha Motor Corporation, U.S.A.

To contact NHTSA, you may either call the Auto Safety Hotline toll-free at 1-800-424-9393 (or 366-0123 in Washington, D.C. area) or write to: NHTSA, U.S. Department of Transportation, Washington, D.C. 20590. You can also obtain other information about motor vehicle safety from the Hotline.

Motorcycle noise regulation

TAMPERING WITH NOISE CONTROL SYSTEM PROHIBITED:

Federal law prohibits the following acts or the causing thereof: (1) The removal or rendering inoperative by any person other than for purposes of maintenance, repair, or replacement of any device or element of design incorporated into any new vehicle for the purpose of noise control prior to its sale or delivery to the ultimate purchaser or while it is in use or (2) the use of the vehicle after such device or element of design has been removed or rendered inoperative by any person.

“AMONG THOSE ACTS PRESUMED TO CONSTITUTE TAMPERING ARE THE ACTS LISTED BELOW”.

These acts include tampering with the following systems; i.e., modification, removal, etc.

Exhaust system	Muffler Exhaust pipe Silencer
Intake system	Air cleaner case Air cleaner element Intake duct

CONSUMER INFORMATION

EAU01874

Maintenance record

Copies of work orders and/or receipts for parts purchased and installed on your motorcycle will be required to document that maintenance has been completed in accordance with the emissions warranty. The chart below is printed only as a reminder that maintenance work is required. It is not acceptable proof of maintenance work.

Maintenance interval	Date of service	Mileage	Servicing dealer name and address	Remarks
600 mi (1,000 km) or 1 month				
4,000 mi (7,000 km) or 6 months				
8,000 mi (13,000 km) or 12 months				
12,000 mi (19,000 km) or 18 months				
16,000 mi (25,000 km) or 24 months				
20,000 mi (31,000 km) or 30 months				
24,000 mi (37,000 km) or 36 months				

CONSUMER INFORMATION

Maintenance interval	Date of service	Mileage	Servicing dealer name and address	Remarks
28,000 mi (43,000 km) or 42 months				
32,000 mi (49,000 km) or 48 months				
36,000 mi (55,000 km) or 54 months				
40,000 mi (61,000 km) or 60 months				

YAMAHA MOTOR CORPORATION, U.S.A. STREET AND ENDURO MOTORCYCLE LIMITED WARRANTY

Yamaha Motor Corporation, U.S.A. hereby warrants each new model Yamaha motorcycle will be free from defects in material and workmanship for the period of time stated herein, subject to certain stated limitations.

THE PERIOD OF WARRANTY for Yamaha motorcycles originally equipped with headlight, stoplight, and turn signals shall be one (1) year from the date of purchase, with no mileage limitation.

MODELS EXCLUDED FROM WARRANTY include those used for non-Yamaha-authorized renting, leasing, or other commercial purposes, and TZ models.

DURING THE PERIOD OF WARRANTY any authorized Yamaha motorcycle dealer will, free of charge, repair or replace any part adjudged defective by Yamaha due to faulty workmanship or material from the factory. Parts used in warranty repairs will be warranted for the balance of the product's warranty period. All parts replaced under warranty become property of Yamaha Motor Corp. U.S.A.

GENERAL EXCLUSIONS from this warranty shall include any failures caused by:

- Competition or racing use.
- Installation of parts or accessories that are not qualitatively equivalent to genuine Yamaha parts.
- Abnormal strain, neglect, or abuse.
- Lack of proper maintenance.
- Accident or collision damage.
- Modification to original parts.

SPECIFIC EXCLUSIONS from this warranty shall include parts replaced due to normal wear or routine maintenance.

THE CUSTOMER'S RESPONSIBILITY under this warranty shall be to:

- Operate and maintain the motorcycle as specified in the appropriate Owner's Manual, and
- Give notice to an authorized Yamaha motorcycle dealer of any and all apparent defects within ten (10) days after discovery, and make the machine available at that time for inspection and repairs at such dealer's place of business.

WARRANTY TRANSFER: To transfer the warranty from the original purchaser to any subsequent purchaser, it is imperative that the machine be inspected and registered for warranty by an authorized Yamaha motorcycle dealer. In order for this warranty to remain in effect, this inspection and registration must take place within ten (10) days after transfer. An inspection and registration fee will be charged for this service.

EMISSIONS CONTROL SYSTEM WARRANTY

Yamaha Motor Corporation, U.S.A. also warrants to the ultimate purchaser and each subsequent purchaser of each Yamaha motorcycle covered by this warranty with a displacement of 50cc or greater, that the vehicle is designed, built, and equipped so as to conform at the time of sale with all U.S. emissions standards applicable at the time of manufacture and that it is free from defects in materials and workmanship which would cause it not to meet these standards within the periods listed immediately below. Failure other than those resulting from defects in material or workmanship which arise solely as a result of owner abuse and / or lack of proper maintenance are not covered by this warranty.

ENGINE DISPLACEMENT	PERIOD
50cc to 169cc	12,000 km (7,465 miles) or five years, whichever occurs first
170cc to 279cc	18,000 km (11,185 miles) or five years, whichever occurs first
280cc or over	30,000 km (18,641 miles) or five years, whichever occurs first

YAMAHA MOTOR CORPORATION, U.S.A. MAKES NO OTHER WARRANTY OF ANY KIND, EXPRESSED OR IMPLIED. ALL IMPLIED WARRANTIES OF MERCHANTABILITY AND FITNESS FOR A PARTICULAR PURPOSE WHICH EXCEED THE OBLIGATIONS AND TIME LIMITS STATED IN THIS WARRANTY ARE HEREBY DISCLAIMED BY YAMAHA MOTOR CORPORATION, U.S.A. AND EXCLUDED FROM THIS WARRANTY.

SOME STATES DO NOT ALLOW LIMITATIONS ON HOW LONG AN IMPLIED WARRANTY LASTS, SO THE ABOVE LIMITATION MAY NOT APPLY TO YOU. ALSO EXCLUDED FROM THIS WARRANTY ARE ANY INCIDENTAL OR CONSEQUENTIAL DAMAGES INCLUDING LOSS OF USE. SOME STATES DO NOT ALLOW THE EXCLUSION OR LIMITATION OF INCIDENTAL OR CONSEQUENTIAL DAMAGES, SO THE ABOVE EXCLUSION MAY NOT APPLY TO YOU.

THIS WARRANTY GIVES YOU SPECIFIC LEGAL RIGHTS, AND YOU MAY ALSO HAVE OTHER RIGHTS WHICH VARY FROM STATE TO STATE.

YAMAHA MOTOR CORPORATION, U.S.A.
P.O. Box 6555
Cypress, California 90630

WARRANTY QUESTIONS AND ANSWERS

- Q. What costs are my responsibility during the warranty period?
- A. The customer's responsibility includes all costs of normal maintenance services, non-warranty repairs, accident and collision damages, and oil, oil filters, air filters, spark plugs, and brake shoes.
- Q. What are some examples of "abnormal" strain, neglect, or abuse?
- A. These terms are general and overlap each other in areas. Specific examples include: Running the machine out of oil, sustained high-rpm, full-throttle, operating the machine with a broken or damaged part which causes another part to fail, damage or failure due to improper or careless transportation and or tie down. If you have any specific questions on operation or maintenance, please contact your dealer for advice.
- Q. Does the warranty cover incidental costs such as towing or transportation due to a failure?
- A. No. The warranty is limited to repair of the machine itself.
- Q. May I perform any or all of the recommended maintenance shown in the Owner's Manual instead of having the dealer do them?
- A. Yes, if you are a qualified mechanic and follow the procedures specified in the Owner's and Service Manual. We do recommend, however, that items requiring special tools or equipment be done by Yamaha Motorcycle dealer.
- Q. Will the warranty be void or cancelled if I do not operate or maintain my new motorcycle exactly as specified in the Owner's Manual?
- A. No. The warranty on a new motorcycle cannot be "voided" or "cancelled." **However, if a particular failure is caused by operation or maintenance other than as shown in the Owner's Manual, that failure may not be covered under warranty.**
- Q. What responsibility does my dealer have under this warranty?
- A. Each Yamaha Motorcycle dealer is expected to:
1. Completely set up every new machine before sale.
 2. Explain the operation, maintenance, and warranty requirements to your satisfaction at the time of sale, and upon your request at any later date.
 3. Each Yamaha Motorcycle dealer is held responsible for his setup, service and warranty repair work.
- Q. Is the warranty transferable to second owners?
- A. Yes. The remainder of the existing warranty can be transferred upon request. The unit has to be inspected and re-registered by an authorized Yamaha Motorcycle dealer for the policy to remain effective.

CUSTOMER SERVICE

If your machine requires warranty service, you must take it to any authorized Yamaha Motorcycle dealer within the continental United States. Be sure to bring your warranty registration card or other valid proof of the original date of purchase. If a question or problem arises regarding warranty, first contact the owner of the dealership. Since all warranty matters are handled at the dealer level, this person is in the best position to help you. If you are still not satisfied and require additional assistance, please write:

YAMAHA MOTOR CORPORATION U.S.A.
CUSTOMER RELATIONS DEPARTMENT
P.O. Box 6555
Cypress, California 90630

When contacting Yamaha Motor Corporation, U.S.A. don't forget to include any important information such as names, addresses, model, V.I.N. (frame number), dates, and receipts.

CHANGE OF ADDRESS

The federal government requires each manufacturer of a motor vehicle to maintain a complete, up-to-date list of all first purchasers against the possibility of a safety-related defect and recall. This list is compiled from the purchase registrations sent to Yamaha Motor Corporation, U.S.A. by the selling dealer at the time of your purchase.

If you should move after you have purchased your new motorcycle, please advise us of your new address by sending a postcard listing your motorcycle model name, V.I.N. (frame number), dealer number (or dealer's name) as it is shown on your warranty card, your name and new mailing address. Mail to:

YAMAHA MOTOR CORPORATION, U.S.A.
P.O. Box 6555
Cypress, California 90630
Attention: Warranty Department

This will ensure that Yamaha Motor Corporation, U.S.A. has an up-to-date registration record in accordance with federal law.

YAMAHA EXTENDED SERVICE (Y.E.S.)

Keep your Yamaha protected even after your warranty expires with genuine Yamaha Extended Service (Y.E.S.).

- Y.E.S. is designed and administered by Yamaha Motor Corporation to provide maximum owner satisfaction. You get uninterrupted factory-backed coverage for extra peace of mind.
- Y.E.S. is flexible. You choose the plan that's right for you: 12 months, 24 months, or 36 months beyond your warranty period.
- Y.E.S. is designed and administered by the same Yamaha people who handle your warranty – and it shows in the comprehensive coverage benefits. There are no mileage limitations. Coverage isn't limited to "moving parts" or the "drive train" like many other plans. And Y.E.S. covers manufacturing defects just like the warranty. See the sample contract at your Yamaha dealer to see how comforting uninterrupted factory-backed protection can be.
- You don't have to pay anything for covered repairs. There's no deductible to pay, and repairs aren't "pro-rated." You don't have any "out-of-pocket" expenses for covered repairs.
- In addition, Travel and Recreation Interruption Protection (TRIP) is included at no extra cost. TRIP gives you up to \$150 reimbursement per occurrence for any reasonable expenses you incur because your Yamaha needs covered service: replacement vehicle rental, emergency towing, phone calls, even food and lodging when you are away from home. This superb coverage goes into effect when you purchase Y.E.S., so it applies to any warranty repairs as well as covered repairs during your entire Y.E.S. plan period.
- Y.E.S. coverage is honored at any authorized Yamaha dealer nationwide.
- Y.E.S. coverage is transferable to a new owner if you sell or trade-in. That can make your Yamaha much more valuable!

This excellent Y.E.S. plan coverage is only available to Yamaha owners like you, and only while your Yamaha is still within the Yamaha Limited Warranty period. So visit your authorized Yamaha dealer to get all the facts. He can show you how easy it is to protect your investment with Yamaha Extended Service.

CONSUMER INFORMATION

We urge you to act now. You'll get the excellent benefits of TRIP coverage right away, and you'll rest easy knowing you'll have strong factory-backed protection even after your Yamaha Limited Warranty expires. You can also save money: Y.E.S. costs less within the first 90 days after you buy your Yamaha. See your dealer today!

A special note:

If visiting your dealer isn't convenient, contact Yamaha with your Primary ID number (your frame number). We'll be happy to help you get the Y.E.S. coverage you need.

Yamaha Service Marketing
P.O. Box 6555
Cypress, CA 90630



YAMAHA EXTENDED SERVICE

INDEX

A

- Accessories and replacement parts6-25
- Air filter element, cleaning6-21

B

- Battery6-35
- Brake and clutch levers, checking and lubricating6-32
- Brake and shift pedals, checking and lubricating6-31
- Brake fluid, changing6-30
- Brake fluid level, checking.....6-29
- Brake lever.....3-5
- Brake lever free play, adjusting6-27
- Brake light switch (rear), adjusting6-28
- Brake pads, checking.....6-28
- Brake pedal.....3-6
- Brake pedal position, adjusting6-27

C

- Cables, checking and lubricating.....6-30
- Canister (for California only).....6-11
- Carburetors, adjusting.....6-22
- Care.....7-1
- Centerstand and sidestand, checking and lubricating6-32
- Clutch lever3-5
- Clutch lever free play6-26
- Coolant6-16
 - Changing.....6-17
 - Checking6-16
- Coolant temperature gauge3-3
- Cowlings and panels, removing and installing6-8

D

- Dimmer switch.....3-3

E

- Engine break-in5-5
- Engine oil and oil filter cartridge6-11
- Engine stop switch.....3-4

F

- Final gear oil6-15
- Front fork, adjusting3-11
- Front fork, checking6-33
- Fuel3-7
- Fuel level warning light3-2
- Fuel reserve switch.....3-4
- Fuel tank cap.....3-6
- Fuses, replacing6-39

H

- Handlebar switches3-3
- Headlight bulb, replacing6-40
- Helmet holder3-10
- High beam indicator light3-2
- Horn switch3-4

I

- Identification numbers9-1
- Ignition circuit cut-off system.....3-17
- Indicator and warning lights3-1

K

- Key identification number9-1

L

- Labels, location1-7

M

- Main switch3-1
- Maintenance and lubrication, periodic6-5
- Maintenance and repair6-1
- Maintenance, emission control system.....6-3
- Maintenance, periodic6-1
- Maintenance record9-5
- Model label9-2

N

- Neutral indicator light3-1
- Noise regulation9-4

O

- Oil level warning light3-2

P

- Parking.....5-6
- Part locations2-1
- Pre-operation check list.....4-1

R

- Rider seat3-9

S

- Safety defects, reporting9-3
- Safety information1-1
- Shifting.....5-3
 - Decelerating5-4
 - Shift points.....5-5
 - Starting out and accelerating5-4
- Shift pedal3-5
- Shock absorber assemblies, adjusting ...3-12
- Sidestand.....3-17
- Spark plugs, checking6-9

Specifications	8-1
Speedometer unit	3-2
Starter (choke) lever	3-8
Starting and warming up a cold engine.....	5-1
Starting a warm engine.....	5-3
Start switch.....	3-4
Steering, checking.....	6-34
Steering lock.....	3-9
Storage.....	7-4
Suspension (rear), lubricating	6-33
Suspension settings, matching front and rear.....	3-15

T

Tachometer	3-3
Throttle cable free play, adjusting	6-22
Throttle grip and cable, checking and lubricating.....	6-31
Tires	6-23
Tool kit.....	6-1
Troubleshooting.....	6-45
Troubleshooting charts	6-46
Turn signal indicator light	3-1
Turn signal light bulb or the tail/brake light bulb, replacing	6-41
Turn signal switch.....	3-3

V

Valve clearance, adjusting.....	6-22
V-Boost	3-16
Vehicle identification number	9-1

W

Warranty, extended.....	9-9
Warranty, limited	9-7
Wheel bearings, checking	6-35
Wheel (front)	6-42
Installing	6-42
Removing	6-42
Wheel (rear)	6-43
Installing	6-45
Removing	6-43
Wheels.....	6-25

PROTECT YOUR INVESTMENT

Use Genuine YAMAHA Parts And Accessories

***See your Authorized YAMAHA Dealer for a Genuine YAMAHA
Service Manual.***



YAMAHA

YAMAHA MOTOR CO., LTD.

PRINTED ON RECYCLED PAPER

PRINTED IN JAPAN
2000 · 4 - 0.4 × 1 CR
(E)