



OWNER'S MANUAL

*Virago*

**XV250R**  
**XV250RC**

LIT-11626-16-21

2UJ-28199-1B

EAU03438

**⚠ WARNING**

**The engine exhaust from this product contains chemicals known to the State of California to cause cancer, birth defects or other reproductive harm.**

YAMAHA

LIT-CALIF-65-01

Congratulations on your purchase of the Yamaha XV250/XV250C. This model is the result of Yamaha's vast experience in the production of fine sporting, touring, and pacesetting racing machines. It represents the high degree of craftsmanship and reliability that have made Yamaha a leader in these fields.

This manual will give you an understanding of the operation, inspection, and basic maintenance of this motorcycle. If you have any questions concerning the operation or maintenance of your motorcycle, please consult a Yamaha dealer.

The design and manufacture of this Yamaha motorcycle fully comply with the emissions standards for clean air applicable at the date of manufacture. Yamaha has met these standards without reducing the performance or economy of operation of the motorcycle. To maintain these high standards, it is important that you and your Yamaha dealer pay close attention to the recommended maintenance schedules and operating instructions contained within this manual.

# IMPORTANT MANUAL INFORMATION

---

---

EAU00003

Particularly important information is distinguished in this manual by the following notations:



The Safety Alert Symbol means **ATTENTION! BECOME ALERT! YOUR SAFETY IS INVOLVED!**



Failure to follow **WARNING** instructions could result in severe injury or death to the motorcycle operator, a bystander or a person inspecting or repairing the motorcycle.

**CAUTION:**

A **CAUTION** indicates special precautions that must be taken to avoid damage to the motorcycle.

**NOTE:**

A **NOTE** provides key information to make procedures easier or clearer.

**NOTE:** \_\_\_\_\_

- This manual should be considered a permanent part of this motorcycle and should remain with it even if the motorcycle is subsequently sold.
  - Yamaha continually seeks advancements in product design and quality. Therefore, while this manual contains the most current product information available at the time of printing, there may be minor discrepancies between your motorcycle and this manual. If you have any questions concerning this manual, please consult your Yamaha dealer.
-

# IMPORTANT MANUAL INFORMATION

---

---

EW000000

## **WARNING**

PLEASE READ THIS MANUAL AND THE “YOU AND YOUR MOTORCYCLE: RIDING TIPS” BOOKLET CAREFULLY AND COMPLETELY BEFORE OPERATING THIS MOTORCYCLE. DO NOT ATTEMPT TO OPERATE THIS MOTORCYCLE UNTIL YOU HAVE ATTAINED ADEQUATE KNOWLEDGE OF ITS CONTROLS AND OPERATING FEATURES AND UNTIL YOU HAVE BEEN TRAINED IN SAFE AND PROPER RIDING TECHNIQUES. REGULAR INSPECTIONS AND CAREFUL MAINTENANCE, ALONG WITH GOOD RIDING SKILLS, WILL ENSURE THAT YOU SAFELY ENJOY THE CAPABILITIES AND THE RELIABILITY OF THIS MOTORCYCLE.

---

# **IMPORTANT MANUAL INFORMATION**

---

---

AFFIX DEALER

LABEL HERE

EAU04247

**XV250R/XV250RC  
OWNER'S MANUAL  
©2002 by Yamaha Motor Corporation, U.S.A.  
1st edition, April 2002  
All rights reserved.  
Any reprinting or unauthorized use  
without the written permission of  
Yamaha Motor Corporation, U.S.A.  
is expressly prohibited.  
Printed in Japan.  
P/N LIT-11626-16-21**

<b>1</b>	<b>SAFETY INFORMATION</b> .....	1-1	Helmet holder .....	3-9
	Safe riding .....	1-1	Adjusting the shock absorber assemblies .....	3-10
	Protective apparel .....	1-3	Sidestand .....	3-10
	Modifications .....	1-3	Ignition circuit cut-off system .....	3-11
	Loading and accessories .....	1-3		
	Gasoline and exhaust gas.....	1-5		
	Location of important labels .....	1-7		
<b>2</b>	<b>DESCRIPTION</b> .....	2-1	<b>4</b>	<b>PRE-OPERATION CHECKS</b> .....
	Left view .....	2-1		Pre-operation check list .....
	Right view .....	2-2		4-1
	Controls and instruments .....	2-3	<b>5</b>	<b>OPERATION AND IMPORTANT RIDING</b>
<b>3</b>	<b>INSTRUMENT AND CONTROL FUNCTIONS</b> ...	3-1		<b>POINTS</b> .....
	Main switch .....	3-1		Starting and warming up a cold engine .....
	Indicator lights .....	3-1		5-2
	Speedometer unit .....	3-2		Starting a warm engine .....
	Handlebar switches .....	3-2		5-3
	Clutch lever .....	3-3		Shifting .....
	Shift pedal .....	3-3		5-4
	Brake lever .....	3-4		Engine break-in .....
	Brake pedal .....	3-4		5-5
	Fuel tank cap .....	3-4		Parking .....
	Fuel .....	3-5		5-6
	Fuel cock .....	3-6	<b>6</b>	<b>PERIODIC MAINTENANCE AND MINOR</b>
	Starter (choke) lever .....	3-7		<b>REPAIR</b> .....
	Steering lock .....	3-8		Periodic maintenance .....
	Rider seat .....	3-8		6-1
				Owner's tool kit .....
				6-2
				Periodic maintenance chart for the emission
				control system .....
				6-3
				General maintenance and lubrication chart .....
				6-4
				Checking the spark plugs .....
				6-6
				Canister (for California only) .....
				6-8
				Engine oil and oil filter element .....
				6-8
				Cleaning the air filter element .....
				6-11
				Adjusting the carburetor .....
				6-13

# TABLE OF CONTENTS

---

---

Adjusting the throttle cable free play .....	6-13
Adjusting the valve clearance .....	6-14
Tires .....	6-14
Spoke wheels .....	6-16
Accessories and replacement parts .....	6-16
Adjusting the clutch lever free play .....	6-17
Adjusting the brake lever free play .....	6-18
Adjusting the brake pedal position and free play .....	6-18
Adjusting the rear brake light switch .....	6-20
Checking the front brake pads and rear brake shoes .....	6-20
Checking the brake fluid level .....	6-21
Changing the brake fluid .....	6-22
Drive chain slack .....	6-22
Lubricating the drive chain .....	6-25
Checking and lubricating the cables .....	6-25
Checking and lubricating the throttle grip and cable .....	6-26
Checking and lubricating the brake and shift pedals .....	6-26
Checking and lubricating the brake and clutch levers .....	6-26
Checking and lubricating the sidestand .....	6-27
Checking the front fork .....	6-27
Checking the steering .....	6-28
Checking the wheel bearings .....	6-28
Battery .....	6-29

Replacing the fuses .....	6-31
Replacing the headlight bulb .....	6-32
Supporting the motorcycle .....	6-33
Front wheel .....	6-34
Rear wheel .....	6-36
Troubleshooting .....	6-37
Troubleshooting chart .....	6-38

<b>7</b>	<b>MOTORCYCLE CARE AND STORAGE .....</b>	<b>7-1</b>
	Care .....	7-1
	Storage .....	7-4

<b>8</b>	<b>SPECIFICATIONS.....</b>	<b>8-1</b>
	Specifications .....	8-1

<b>9</b>	<b>CONSUMER INFORMATION.....</b>	<b>9-1</b>
	Identification numbers .....	9-1
	Key identification number .....	9-1
	Vehicle identification number .....	9-1
	Model label .....	9-2
	<b>REPORTING SAFETY DEFECTS .....</b>	<b>9-3</b>
	<b>MOTORCYCLE NOISE REGULATION .....</b>	<b>9-4</b>
	Maintenance record .....	9-5
	Street and enduro motorcycle limited warranty.....	9-7
	Yamaha extended service (Y.E.S.) .....	9-9





MOTORCYCLES ARE SINGLE TRACK VEHICLES. THEIR SAFE USE AND OPERATION ARE DEPENDENT UPON THE USE OF PROPER RIDING TECHNIQUES AS WELL AS THE EXPERTISE OF THE OPERATOR. EVERY OPERATOR SHOULD KNOW THE FOLLOWING REQUIREMENTS BEFORE RIDING THIS MOTORCYCLE.

HE OR SHE SHOULD:

1. OBTAIN THOROUGH INSTRUCTIONS FROM A COMPETENT SOURCE ON ALL ASPECTS OF MOTORCYCLE OPERATION.
2. OBSERVE THE WARNINGS AND MAINTENANCE REQUIREMENTS IN THE OWNER'S MANUAL.
3. OBTAIN QUALIFIED TRAINING IN SAFE AND PROPER RIDING TECHNIQUES.
4. OBTAIN PROFESSIONAL TECHNICAL SERVICE AS INDICATED BY THE OWNER'S MANUAL AND/OR WHEN MADE NECESSARY BY MECHANICAL CONDITIONS.

## Safe riding

1. Always make pre-operation checks. Careful checks may help prevent an accident.
2. This motorcycle is designed to carry the operator and a passenger.
3. The failure of motorists to detect and recognize motorcycles in traffic is the predominating cause of automobile/motorcycle accidents. Many accidents have been caused by an automobile driver who did not see the motorcycle. Making yourself conspicuous appears to be very effective in reducing the chance of this type of accident.

Therefore:

- a. Wear a brightly colored jacket.
- b. Use extra caution when approaching and passing through intersections, since intersections are the most likely places for motorcycle accidents to occur.
- c. Ride where other motorists can see you. Avoid riding in another motorist's blind spot.

4. Many motorcycle accidents involve inexperienced operators. In fact, many operators who have been involved in accidents do not even have a current motorcycle license.
  - a. Make sure that you are qualified and that you only lend your motorcycle to other qualified operators.
  - b. Know your skills and limits. Staying within your limits may help you to avoid an accident.
  - c. We recommend that you practice riding your motorcycle where there is no traffic until you have become thoroughly familiar with the motorcycle and all of its controls.
5. Many motorcycle accidents have been caused by error of the motorcycle operator. A typical error made by the operator is veering wide on a turn due to **EXCESSIVE SPEED** or undercornering (insufficient lean angle for the speed).
  - a. Always obey the speed limit and never travel faster than warranted by road and traffic conditions.
  - b. Always signal before turning or changing lanes. Make sure that other motorists can see you.
6. The posture of the operator and passenger is important for proper control.
  - a. The operator should keep both hands on the handlebar and both feet on the operator footrests during operation to maintain control of the motorcycle.
  - b. The passenger should always hold onto the operator, seat strap, or grab bar, if equipped, with both hands and keep both feet on the passenger footrests.
  - c. Never carry a passenger unless he or she can firmly place both feet on the passenger footrests.
7. Never ride under the influence of alcohol or other drugs.
8. This motorcycle is designed for on-road use only, therefore, it is not suitable for off-road use.



# SAFETY INFORMATION

---

---

## Protective apparel

The majority of fatalities from motorcycle accidents are the result of head injuries. The use of a safety helmet is the single most critical factor in the prevention or reduction of head injuries.

1. Always wear an approved helmet.
2. Wear a face shield or goggles. Wind in your unprotected eyes could contribute to an impairment of vision which could delay seeing a hazard.
3. The use of a jacket, heavy boots, trousers, gloves, etc., is effective in preventing or reducing abrasions or lacerations.
4. Never wear loose-fitting clothes, otherwise they could catch on the control levers, footrests, or wheels and cause injury or an accident.
5. Never touch the engine or exhaust system during or after operation. They become very hot and can cause burns. Always wear protective clothing that covers your legs, ankles, and feet.
6. Passengers should also observe the precautions mentioned above.

## Modifications

Modifications made to this motorcycle not approved by Yamaha, or the removal of original equipment, may render the motorcycle unsafe for use and may cause severe personal injury. Modifications may also make your motorcycle illegal to use.

## Loading and accessories

Adding accessories or cargo to your motorcycle can adversely affect stability and handling if the weight distribution of the motorcycle is changed. To avoid the possibility of an accident, use extreme caution when adding cargo or accessories to your motorcycle. Use extra care when riding a motorcycle that has added cargo or accessories. Here are some general guidelines to follow if loading cargo or adding accessories to your motorcycle:

## Loading

The total weight of the operator, passenger, accessories and cargo must not exceed the maximum load limit of XV250: 432 lb (196 kg) / XV250C: 430 lb (195 kg). When loading within this weight limit, keep the following in mind:

1. Cargo and accessory weight should be kept as low and close to the motorcycle as possible. Make sure to distribute the weight as evenly as possible on both sides of the motorcycle to minimize imbalance or instability.
2. Shifting weights can create a sudden imbalance. Make sure that accessories and cargo are securely attached to the motorcycle before riding. Check accessory mounts and cargo restraints frequently.
3. Never attach any large or heavy items to the handlebar, front fork, or front fender. These items, including such cargo as sleeping bags, duffel bags, or tents, can create unstable handling or slow steering response.

## Accessories

Genuine Yamaha accessories have been specifically designed for use on this motorcycle. Since Yamaha cannot test all other accessories that may be available, you must personally be responsible for the proper selection, installation and use of non-Yamaha accessories. Use extreme caution when selecting and installing any accessories.

Keep the following guidelines in mind, as well as those provided under “Loading” when mounting accessories.

1. Never install accessories or carry cargo that would impair the performance of your motorcycle. Carefully inspect the accessory before using it to make sure that it does not in any way reduce ground clearance or cornering clearance, limit suspension travel, steering travel or control operation, or obscure lights or reflectors.



# SAFETY INFORMATION

---

---

- a. Accessories fitted to the handlebar or the front fork area can create instability due to improper weight distribution or aerodynamic changes. If accessories are added to the handlebar or front fork area, they must be as lightweight as possible and should be kept to a minimum.
  - b. Bulky or large accessories may seriously affect the stability of the motorcycle due to aerodynamic effects. Wind may attempt to lift the motorcycle, or the motorcycle may become unstable in cross winds. These accessories may also cause instability when passing or being passed by large vehicles.
  - c. Certain accessories can displace the operator from his or her normal riding position. This improper position limits the freedom of movement of the operator and may limit control ability, therefore, such accessories are not recommended.
2. Use caution when adding electrical accessories. If electrical accessories exceed the capacity of the motorcycle's electrical system, an electric failure could result, which could cause a dangerous loss of lights or engine power.

## Gasoline and exhaust gas

1. GASOLINE IS HIGHLY FLAMMABLE:
  - a. Always turn the engine off when refueling.
  - b. Take care not to spill any gasoline on the engine or exhaust system when refueling.
  - c. Never refuel while smoking or in the vicinity of an open flame.
2. Never start the engine or let it run for any length of time in a closed area. The exhaust fumes are poisonous and may cause loss of consciousness and death within a short time. Always operate your motorcycle in an area that has adequate ventilation.
3. Always turn the engine off before leaving the motorcycle unattended and remove the key from the main switch. When parking the motorcycle, note the following:

- a. The engine and exhaust system may be hot, therefore, park the motorcycle in a place where pedestrians or children are not likely to touch these hot areas.
  - b. Do not park the motorcycle on a slope or soft ground, otherwise it may fall over.
  - c. Do not park the motorcycle near a flammable source (e.g. a kerosene heater, or near an open flame), otherwise it could catch fire.
4. When transporting the motorcycle in another vehicle, make sure that it is kept upright and that the fuel cock is turned to “ON” or “RES” (for vacuum type) / “OFF” (for manual type). If it should lean over, gasoline may leak out of the carburetor or fuel tank.
  5. If you should swallow any gasoline, inhale a lot of gasoline vapor, or allow gasoline to get into your eyes, see your doctor immediately. If any gasoline spills on your skin or clothing, immediately wash the affected area with soap and water and change your clothes.

# SAFETY INFORMATION

EAU02977

## Location of important labels

Please read the following important labels carefully before operating this motorcycle.

1

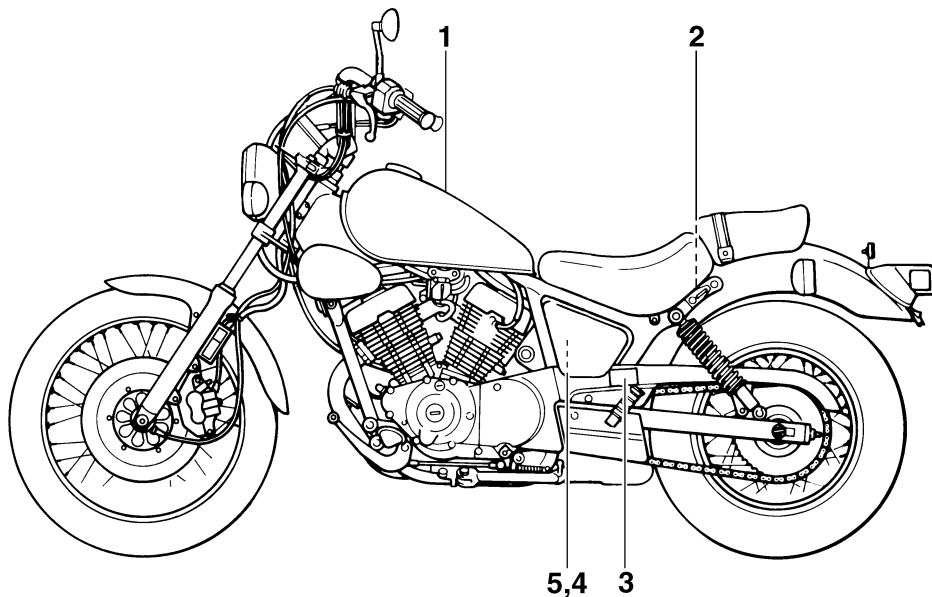

**1**

**⚠ WARNING**

- **BEFORE YOU OPERATE THIS VEHICLE, READ THE OWNER'S MANUAL AND ALL LABELS.**
- **ALWAYS WEAR AN APPROVED MOTORCYCLE HELMET, eye protection, and protective clothing.**

5GK-2118K-00

**2**

**CAUTION**

- Read owner's manual before servicing battery.
- Electrolyte will damage metal parts or paint. If electrolyte spills, wash area with fresh water immediately.
- Be sure to connect breather hose after installing battery.

3JL-28177-A0

**3**

**TIRE INFORMATION**

Cold tire normal pressure should be set as follows.

- Up to 90 kg (198 lbs) load

**FRONT** : 175 kPa, {1.75 kgf/cm<sup>2</sup>}, 25 psi

**REAR** : 200 kPa, {2.00 kgf/cm<sup>2</sup>}, 29 psi- 90 kg (198 lbs) ~ maximum load

**FRONT** : 200 kPa, {2.00 kgf/cm<sup>2</sup>}, 29 psi

**REAR** : 225 kPa, {2.25 kgf/cm<sup>2</sup>}, 33 psi

3CK-21668-A0

**4 California only**

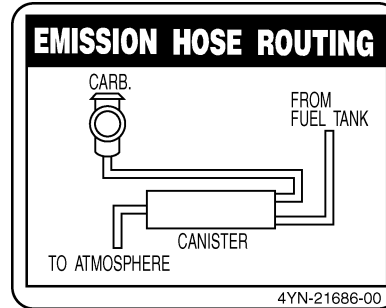

**5 California only**

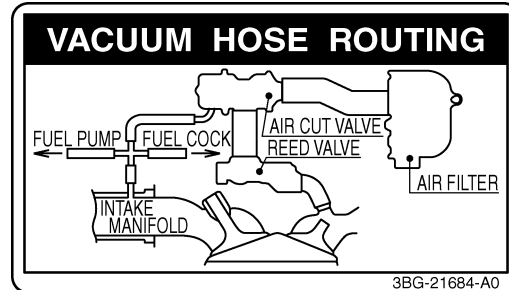

1



## Left view

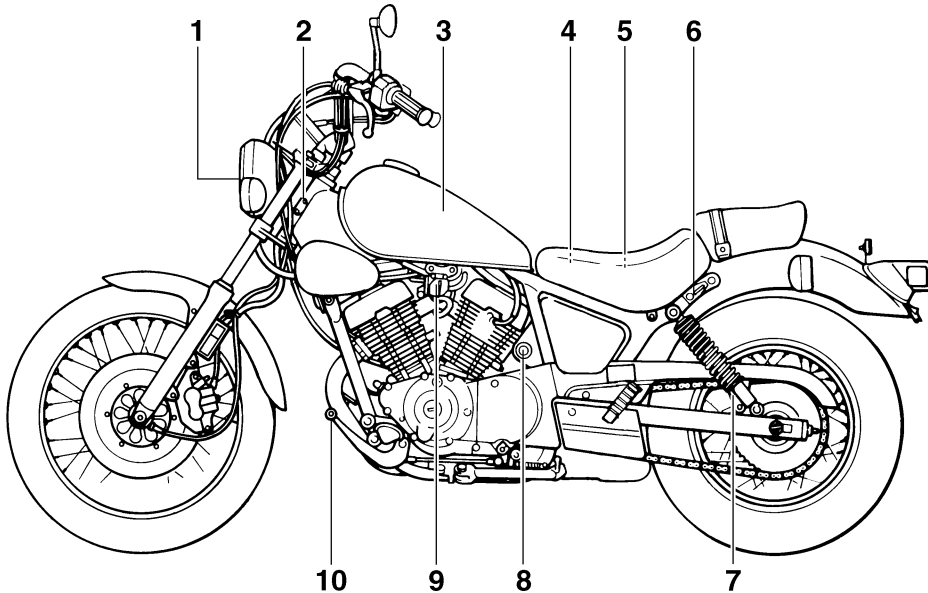

- 1. Headlight
- 2. Steering lock
- 3. Fuel tank
- 4. Battery
- 5. Fuses
- 6. Helmet holder

- (page 6-32)
- (page 3-8)
- (page 3-4)
- (page 6-29)
- (page 6-31)
- (page 3-9)

- 7. Shock absorber assembly spring  
preload adjusting ring
- 8. Main switch
- 9. Fuel cock
- 10. Shift pedal

- (page 3-10)
- (page 3-1)
- (page 3-6)
- (page 3-3)

## Right view

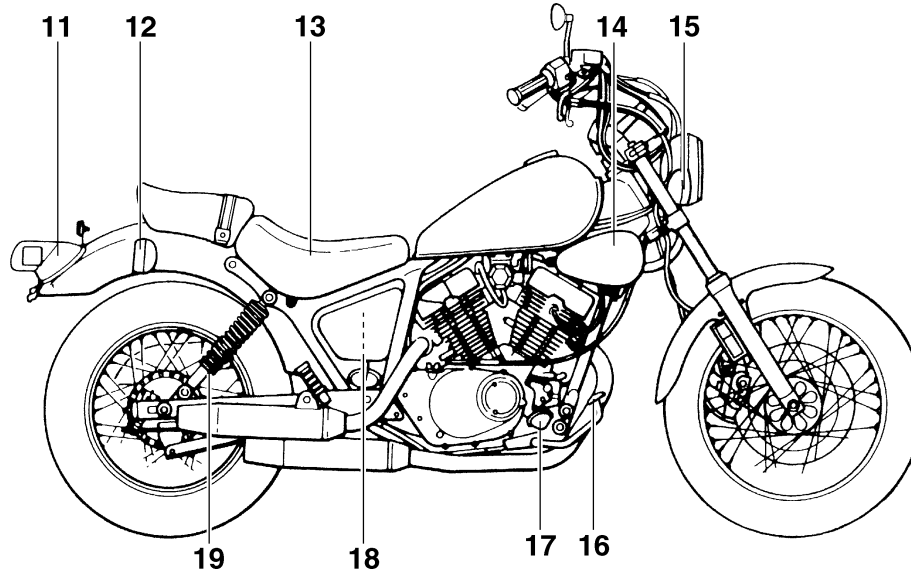

- |  |             |             |
|--|-------------|-------------|
| 11. Tail/brake light   |             |             |
| 12. Rear turn signal light                                   |             |             |
| 13. Rider seat   | (page 3-8)  |             |
| 14. Air filter element                                       | (page 6-11) |             |
| 15. Front turn signal/position light                         |             |             |
| 16. Brake pedal  |             | (page 3-4)  |
| 17. Footrest   |             |             |
| 18. Owner's tool kit   |             | (page 6-2)  |
| 19. Shock absorber assembly spring<br>preload adjusting ring |             | (page 3-10) |

# DESCRIPTION

## Controls and instruments

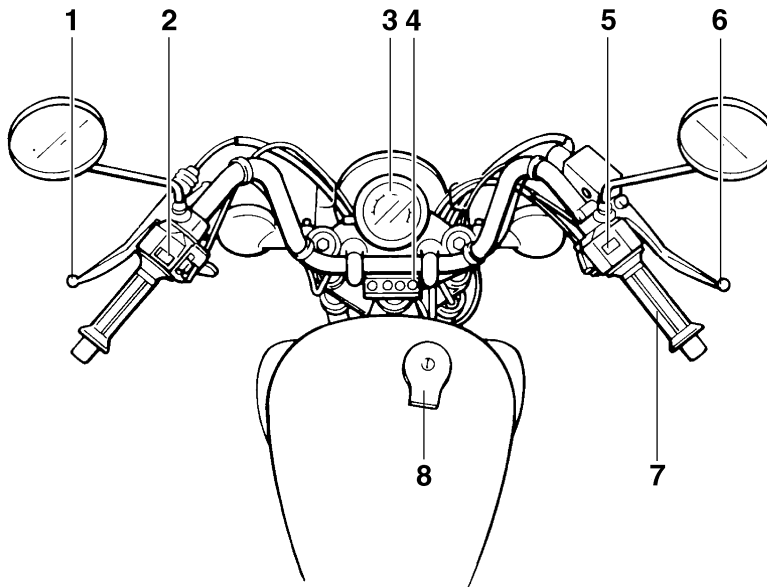

- 1. Clutch lever
- 2. Left handlebar switches
- 3. Speedometer unit
- 4. Indicator lights

(page 3-3)  
(page 3-2)  
(page 3-2)  
(page 3-1)

- 5. Right handlebar switches
- 6. Brake lever
- 7. Throttle grip
- 8. Fuel tank cap

(page 3-3)  
(page 3-4)  
(page 6-13)  
(page 3-4)

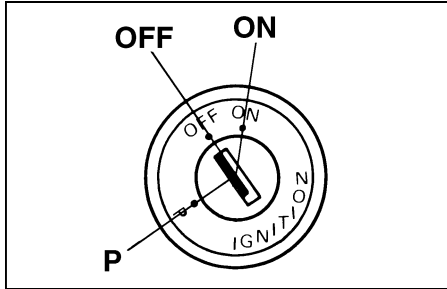

EAU00028

## Main switch

The main switch controls the ignition and lighting systems. The various main switch positions are described below.

### ON

All electrical systems are supplied with power, the headlight, meter lighting, taillight and front position lights come on, and the engine can be started. The key cannot be removed.

EAU00032

### OFF

All electrical systems are off. The key can be removed.

EAU00038

### P (Parking)

The taillight and position lights are on, but all other electrical systems are off. The key can be removed. The key must be pushed in from the "OFF" position to be turned to "P".

EAU00050

### CAUTION:

**Do not use the parking position for an extended length of time, otherwise the battery may discharge.**

ECA00043

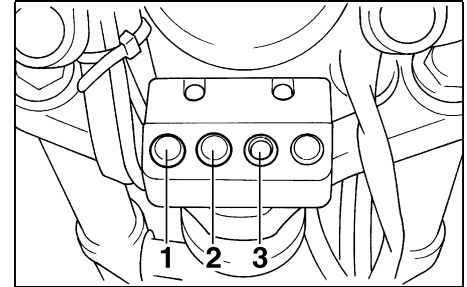

1. High beam indicator light "HIGH BEAM"
2. Neutral indicator light "NEUTRAL"
3. Turn signal indicator light "TURN"

3

EAU00056

## Indicator lights

EAU00064

### High beam indicator light "HIGH BEAM"

This indicator light comes on when the high beam of the headlight is switched on.

EAU00062

### Neutral indicator light "NEUTRAL"

This indicator light comes on when the transmission is in the neutral position.

EAU00059

### Turn signal indicator light "TURN"

This indicator light flashes when the turn signal switch is pushed to the left or right.

# INSTRUMENT AND CONTROL FUNCTIONS

3

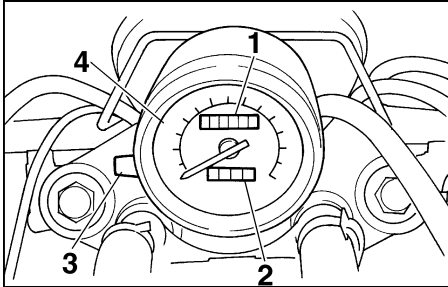

1. Odometer
2. Tripmeter
3. Tripmeter reset knob
4. Speedometer

EAU00095

## Speedometer unit

The speedometer unit is equipped with a speedometer, an odometer and a tripmeter. The speedometer shows riding speed. The odometer shows the total distance traveled. The tripmeter shows the distance traveled since it was last set to zero with the reset knob. The tripmeter can be used to estimate the distance that can be traveled with a full tank of fuel. This information will enable you to plan future fuel stops.

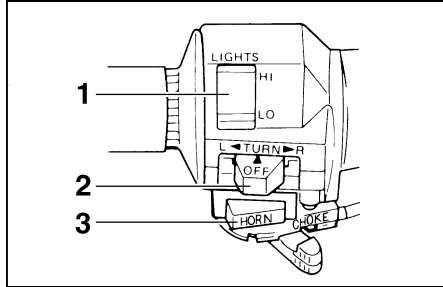

1. Dimmer switch "LIGHTS"
2. Turn signal switch "TURN"
3. Horn switch "HORN"

EAU00118

## Handlebar switches

EAU00122

### Dimmer switch "LIGHTS"

Set the switch to "HI" for the high beam and to "LO" for the low beam.

EAU00125

### Turn signal switch "TURN"

To signal a right-hand turn, push this switch to the right. To signal a left-hand turn, push this switch to the left. When released, the switch returns to the cen-

ter position. To cancel the turn signal lights, push the switch in after it has returned to the center position.

EAU00130

### Horn switch "HORN"

Press this switch to sound the horn.

# INSTRUMENT AND CONTROL FUNCTIONS

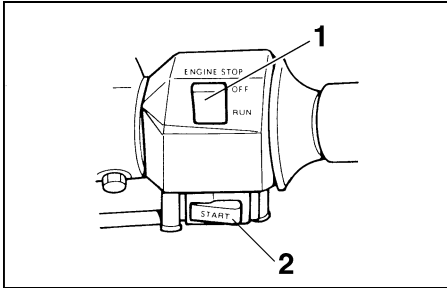

1. Engine stop switch “ENGINE STOP”
2. Start switch “START”

EAU04822

## Engine stop switch “ENGINE STOP”

Set this switch to “RUN” before starting the engine. Set this switch to “OFF” to stop the engine in case of an emergency, such as when the motorcycle overturns or when the throttle cable is stuck.

EAU00141

## Start switch “START”

Push this switch to crank the engine with the starter.

EC000005

### **CAUTION:**

**See page 5-2 for starting instructions prior to starting the engine.**

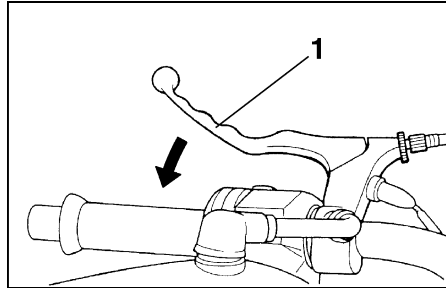

1. Clutch lever

EAU00152

## Clutch lever

The clutch lever is located at the left handlebar grip. To disengage the clutch, pull the lever toward the handlebar grip. To engage the clutch, release the lever. The lever should be pulled rapidly and released slowly for smooth clutch operation.

The clutch lever is equipped with a clutch switch, which is part of the ignition circuit cut-off system. (See page 3-11 for an explanation of the ignition circuit cut-off system.)

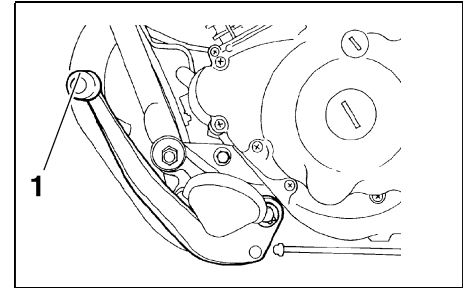

1. Shift pedal

EAU00157

## Shift pedal

The shift pedal is located on the left side of the engine and is used in combination with the clutch lever when shifting the gears of the 5-speed constant-mesh transmission equipped on this motorcycle.

# INSTRUMENT AND CONTROL FUNCTIONS

3

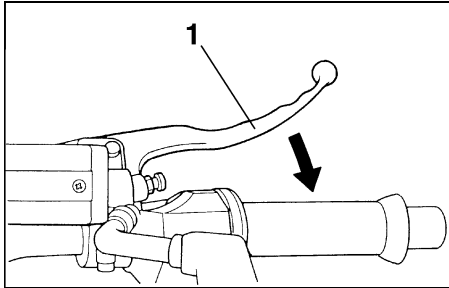

1. Brake lever

EAU00158

## Brake lever

The brake lever is located at the right handlebar grip. To apply the front brake, pull the lever toward the handlebar grip.

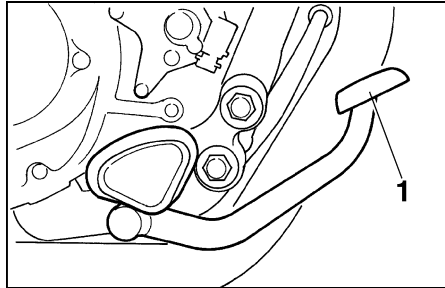

1. Brake pedal

EAU00162

## Brake pedal

The brake pedal is on the right side of the motorcycle. To apply the rear brake, press down on the brake pedal.

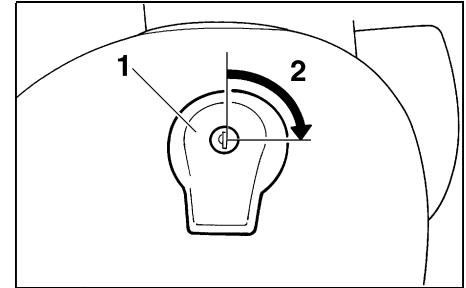

1. Fuel tank cap

2. Unlock.

EAU03712

## Fuel tank cap

### To open the fuel tank cap

Insert the key into the lock and turn it 1/4 turn clockwise. The lock will be released and the fuel tank cap can be opened.

### To close the fuel tank cap

1. Push the fuel tank cap into position with the key inserted in the lock.
2. Turn the key counterclockwise to the original position, and then remove it.

# INSTRUMENT AND CONTROL FUNCTIONS

EAU00185

## NOTE:

The fuel tank cap cannot be closed unless the key is in the lock. In addition, the key cannot be removed if the cap is not properly closed and locked.

EWA00025

## WARNING

Make sure that the fuel tank cap is properly closed before riding.

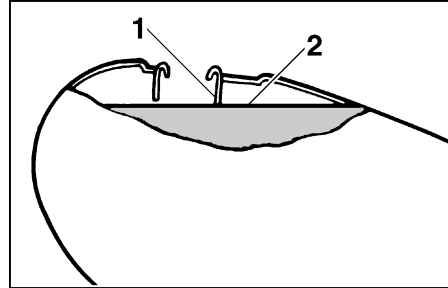

1. Fuel tank filler tube
2. Fuel level

EAU03753

## Fuel

Make sure that there is sufficient fuel in the tank. Fill the fuel tank to the bottom of the filler tube as shown.

EW000130

## WARNING

- Do not overfill the fuel tank, otherwise it may overflow when the fuel warms up and expands.
- Avoid spilling fuel on the hot engine.

## CAUTION:

Immediately wipe off spilled fuel with a clean, dry, soft cloth, since fuel may deteriorate painted surfaces or plastic parts.

EAU04265

Recommended fuel:

UNLEADED GASOLINE ONLY

Fuel tank capacity:

Total amount:

XV250

9.5 L

(2.1 Imp gal, 2.5 US gal)

XV250C

9.2 L

(2.0 Imp gal, 2.4 US gal)

Reserve amount:

2.6 L (0.6 Imp gal, 0.7 US gal)



# INSTRUMENT AND CONTROL FUNCTIONS

ECA00104

## CAUTION:

**Use only unleaded gasoline. The use of leaded gasoline will cause severe damage to internal engine parts, such as the valves and piston rings, as well as to the exhaust system.**

Your Yamaha engine has been designed to use regular unleaded gasoline with a pump octane number [(R+M)/2] of 86 or higher, or a research octane number of 91 or higher. If knocking (or pinging) occurs, use a gasoline of a different brand or premium unleaded fuel. Use of unleaded fuel will extend spark plug life and reduce maintenance costs.

## Gasohol

There are two types of gasohol: gasohol containing ethanol and that containing methanol. Gasohol containing ethanol can be used if the ethanol content does not exceed 10%. Gasohol containing methanol is not recommended by Yamaha because it can cause damage to the fuel system or vehicle performance problems.

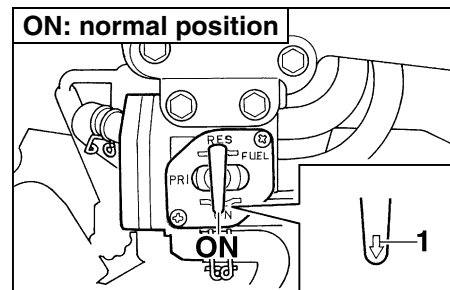

1. Arrow mark positioned over "ON"

EAU04484

## Fuel cock

This motorcycle is equipped with a negative pressure fuel cock. The fuel cock supplies fuel from the tank to the carburetor while also filtering it.

The fuel cock lever positions are explained as follows and shown in the illustrations.

### ON

With the fuel cock lever in this position, fuel flows to the carburetor when the engine is running. Turn the fuel cock lever to this position when starting the engine and riding.

# INSTRUMENT AND CONTROL FUNCTIONS

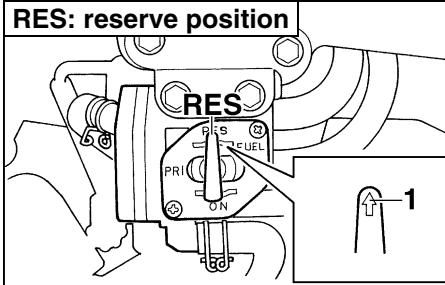

1. Arrow mark positioned over "RES"

## RES

This indicates reserve. With the fuel cock lever in this position, the fuel reserve is made available. Quickly turn the fuel cock lever to this position if you run out of fuel while riding, otherwise the engine may stall and will have to be primed (see "PRI"). After turning the fuel cock lever to "RES", refuel as soon as possible and be sure to turn the fuel cock lever back to "ON"!

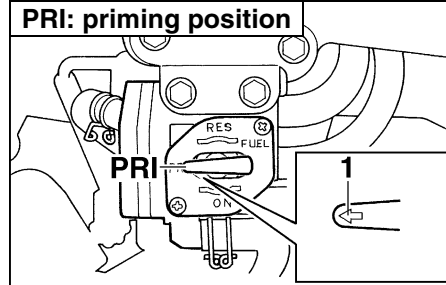

1. Arrow mark positioned over "PRI"

## PRI

This indicates prime. With the fuel cock lever in this position, the engine can be "primed". Turn the fuel cock lever to this position when the engine has been allowed to run out of fuel. This sends fuel directly to the carburetor, which will make starting easier. After the engine has started, be sure to turn the lever to "ON" (or "RES" if you have not refueled yet).

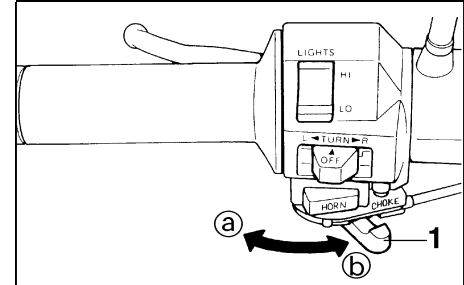

1. Starter (choke) lever

## Starter (choke) lever

Starting a cold engine requires a richer air-fuel mixture, which is supplied by the starter (choke).

Move the lever in direction ① to turn on the starter (choke).

Move the lever in direction ② to turn off the starter (choke).

EAU00211

# INSTRUMENT AND CONTROL FUNCTIONS

3

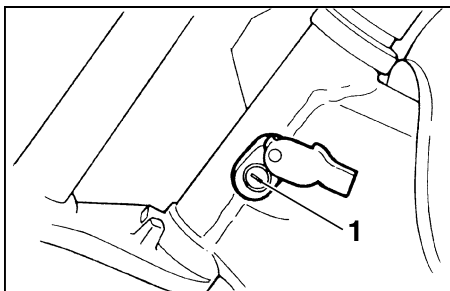

1. Steering lock

EAU02934

## Steering lock

### To lock the steering

1. Turn the handlebar all the way to right.
2. Open the steering lock cover, and then insert the key.
3. Turn the key 1/8 turn counterclockwise, push it in while turning the handlebar slightly to the left, and then turn the key 1/8 turn clockwise.
4. Check that the steering is locked, remove the key, and then close the lock cover.

### To unlock the steering

1. Open the steering lock cover, and then insert the key.
2. Push the key in, turn it 1/8 turn counterclockwise so that it moves out, and then release it.
3. Remove the key, and then close the lock cover.

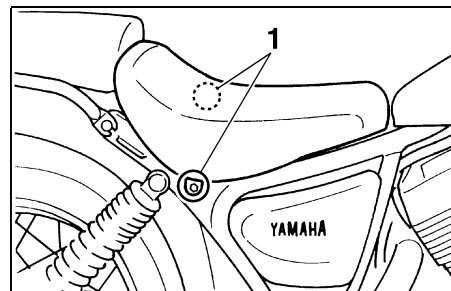

1. Bolt (× 2)

EAU01072

## Rider seat

### To remove the rider seat

Remove the bolts, and then pull the rider seat off.

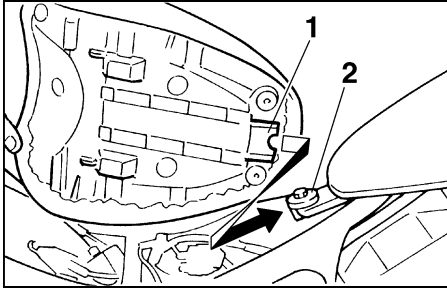

1. Projection
2. Seat holder

## To install the rider seat

1. Insert the projection on the front of the rider seat into the seat holder as shown.
2. Place the rider seat in the original position, and then tighten the bolts.

**NOTE:** \_\_\_\_\_  
Make sure that the rider seat is properly secured before riding.  
\_\_\_\_\_

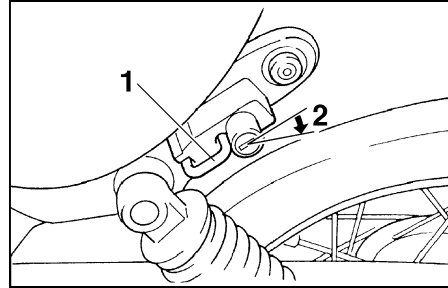

1. Helmet holder
2. Unlock.

## Helmet holder

EAU00260

To open the helmet holder, insert the key into the lock, and then turn the key as shown.

To lock the helmet holder, place it in the original position, and then remove the key.

EW000030



**WARNING** \_\_\_\_\_

**Never ride with a helmet attached to the helmet holder, since the helmet may hit objects, causing loss of control and possibly an accident.**  
\_\_\_\_\_

# INSTRUMENT AND CONTROL FUNCTIONS

EW000040

EAU00330

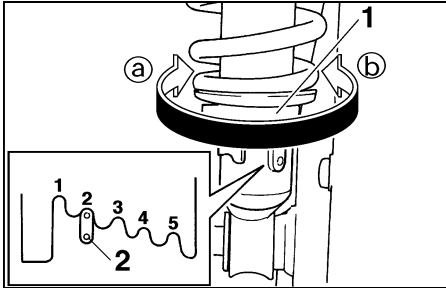

1. Spring preload adjusting ring
2. Position indicator

EAU00300

## Adjusting the shock absorber assemblies

Each shock absorber assembly is equipped with a spring preload adjusting ring.

EC000015

### CAUTION:

Never attempt to turn an adjusting mechanism beyond the maximum or minimum settings.

### ⚠ WARNING

Always adjust both shock absorber assemblies equally, otherwise poor handling and loss of stability may result.

Adjust the spring preload as follows.

To increase the spring preload and thereby harden the suspension, turn the adjusting ring on each shock absorber assembly in direction (a). To decrease the spring preload and thereby soften the suspension, turn the adjusting ring on each shock absorber assembly in direction (b).

### NOTE:

Align the appropriate notch in the adjusting ring with the position indicator on the shock absorber.

	Setting
Minimum (soft)	1
Standard	2
Maximum (hard)	5

## Sidestand

The sidestand is located on the left side of the frame. Raise the sidestand or lower it with your foot while holding the motorcycle upright.

### NOTE:

The built-in sidestand switch is part of the ignition circuit cut-off system, which cuts the ignition in certain situations. (See further down for an explanation of the ignition circuit cut-off system.)

EW000044

EAU03720

## **WARNING**

The motorcycle must not be ridden with the sidestand down, or if the sidestand cannot be properly moved up (or does not stay up), otherwise the sidestand could contact the ground and distract the operator, resulting in a possible loss of control. Yamaha's ignition circuit cut-off system has been designed to assist the operator in fulfilling the responsibility of raising the sidestand before starting off. Therefore, check this system regularly as described below and have a Yamaha dealer repair it if it does not function properly.

## **Ignition circuit cut-off system**

The ignition circuit cut-off system (comprising the sidestand switch, clutch switch and neutral switch) has the following functions.

- It prevents starting when the transmission is in gear and the sidestand is up, but the clutch lever is not pulled.
- It prevents starting when the transmission is in gear and the clutch lever is pulled, but the sidestand is still down.
- It cuts the running engine when the transmission is in gear and the sidestand is moved down.

Periodically check the operation of the ignition circuit cut-off system according to the following procedure.

EW000045

## **WARNING**

If a malfunction is noted, have a Yamaha dealer check the system before riding.

# INSTRUMENT AND CONTROL FUNCTIONS

3

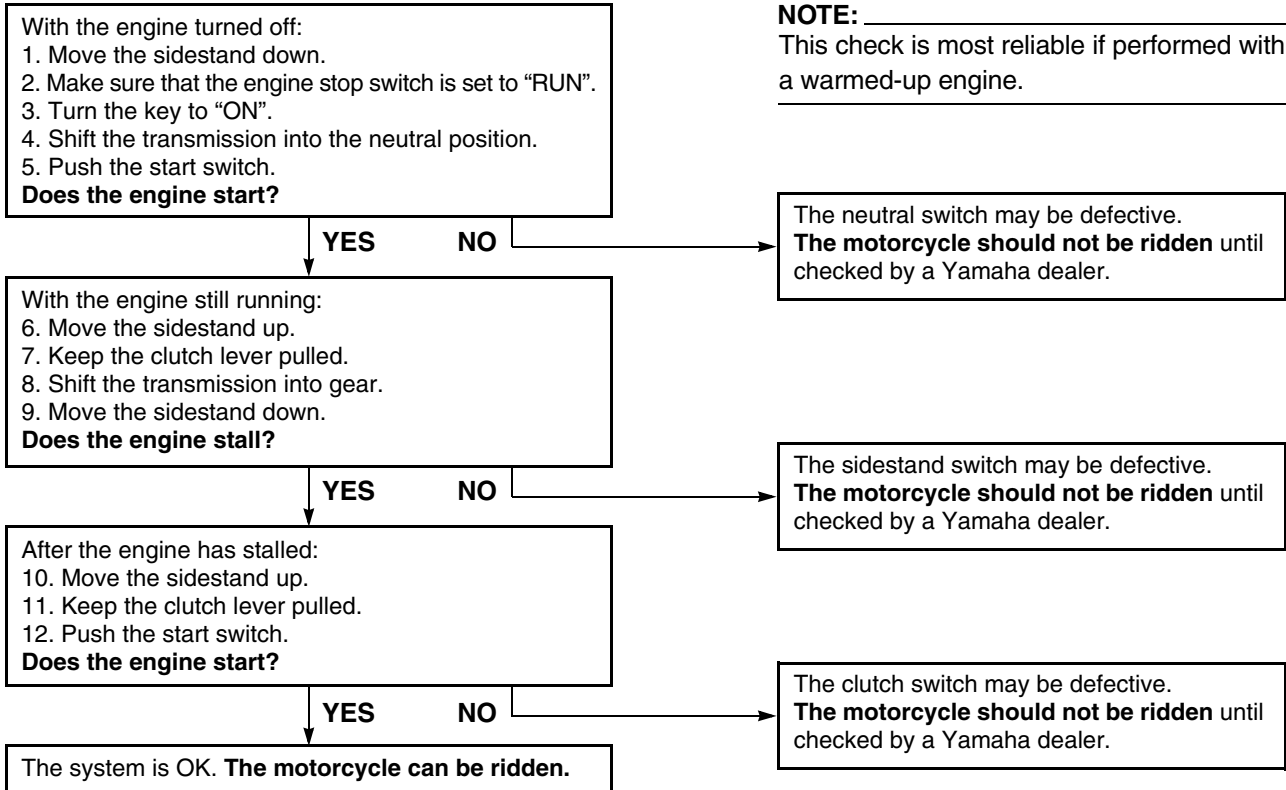

The condition of a vehicle is the owner's responsibility. Vital components can start to deteriorate quickly and unexpectedly, even if the vehicle remains unused (for example, as a result of exposure to the elements). Any damage, fluid leakage or loss of tire air pressure could have serious consequences. Therefore, it is very important, in addition to a thorough visual inspection, to check the following points before each ride.

EAU03439

**Pre-operation check list**

ITEM	CHECKS	PAGE
<b>Fuel</b>	<ul style="list-style-type: none"> <li>• Check fuel level in fuel tank.</li> <li>• Refuel if necessary.</li> <li>• Check fuel line for leakage.</li> </ul>	3-5
<b>Engine oil</b>	<ul style="list-style-type: none"> <li>• Check oil level in engine.</li> <li>• If necessary, add recommended oil to specified level.</li> <li>• Check vehicle for oil leakage.</li> </ul>	6-8-6-9
<b>Front brake</b>	<ul style="list-style-type: none"> <li>• Check operation.</li> <li>• If soft or spongy, have Yamaha dealer bleed hydraulic system.</li> <li>• Check lever free play.</li> <li>• Adjust if necessary.</li> <li>• Check fluid level in reservoir.</li> <li>• If necessary, add recommended brake fluid to specified level.</li> <li>• Check hydraulic system for leakage.</li> </ul>	6-18, 6-20-6-22
<b>Rear brake</b>	<ul style="list-style-type: none"> <li>• Check operation.</li> <li>• Check pedal free play.</li> <li>• Adjust if necessary.</li> </ul>	6-18-6-21
<b>Clutch</b>	<ul style="list-style-type: none"> <li>• Check operation.</li> <li>• Lubricate cable if necessary.</li> <li>• Check lever free play.</li> <li>• Adjust if necessary.</li> </ul>	6-17
<b>Throttle grip</b>	<ul style="list-style-type: none"> <li>• Make sure that operation is smooth.</li> <li>• Check cable free play.</li> <li>• If necessary, have Yamaha dealer adjust cable free play and lubricate cable and grip housing.</li> </ul>	6-13
<b>Control cables</b>	<ul style="list-style-type: none"> <li>• Make sure that operation is smooth.</li> <li>• Lubricate if necessary.</li> </ul>	6-25



# PRE-OPERATION CHECKS

ITEM	CHECKS	PAGE
Drive chain	<ul style="list-style-type: none"> <li>• Check chain slack.</li> <li>• Adjust if necessary.</li> <li>• Check chain condition.</li> <li>• Lubricate if necessary.</li> </ul>	6-22–6-23
Wheels and tires	<ul style="list-style-type: none"> <li>• Check for damage.</li> <li>• Check tire condition and tread depth.</li> <li>• Check air pressure.</li> <li>• Correct if necessary.</li> </ul>	6-14–6-16
Brake and shift pedals	<ul style="list-style-type: none"> <li>• Make sure that operation is smooth.</li> <li>• Lubricate pedal pivoting points if necessary.</li> </ul>	6-26
Brake and clutch levers	<ul style="list-style-type: none"> <li>• Make sure that operation is smooth.</li> <li>• Lubricate lever pivoting points if necessary.</li> </ul>	6-26
Sidestand	<ul style="list-style-type: none"> <li>• Make sure that operation is smooth.</li> <li>• Lubricate pivot if necessary.</li> </ul>	6-27
Chassis fasteners	<ul style="list-style-type: none"> <li>• Make sure that all nuts, bolts and screws are properly tightened.</li> <li>• Tighten if necessary.</li> </ul>	—
Instruments, lights, signals and switches	<ul style="list-style-type: none"> <li>• Check operation.</li> <li>• Correct if necessary.</li> </ul>	—
Sidestand switch	<ul style="list-style-type: none"> <li>• Check operation of ignition circuit cut-off system.</li> <li>• If system is defective, have Yamaha dealer check vehicle.</li> </ul>	3-10–3-11
Battery	<ul style="list-style-type: none"> <li>• Check fluid level.</li> <li>• Fill with distilled water if necessary.</li> </ul>	6-29–6-30

## NOTE:

Pre-operation checks should be made each time the motorcycle is used. Such an inspection can be accomplished in a very short time; and the added safety it assures is more than worth the time involved.

EWA00033

## WARNING

If any item in the Pre-operation check list is not working properly, have it inspected and repaired before operating the motorcycle.

EAU00373

EAU00376

**⚠ WARNING**

- Become thoroughly familiar with all operating controls and their functions before riding. Consult a Yamaha dealer regarding any control or function that you do not thoroughly understand.
  - Never start the engine or operate it in a closed area for any length of time. Exhaust fumes are poisonous, and inhaling them can cause loss of consciousness and death within a short time. Always make sure that there is adequate ventilation.
  - Before starting out, make sure that the sidestand is up. If the sidestand is not raised completely, it could contact the ground and distract the operator, resulting in a possible loss of control.
- 

**CAUTION:**

- Make sure not to store personal items near the air cleaner intake, otherwise air intake will be blocked and performance will suffer.
  - Make sure not to put anything near the battery and its terminals, otherwise electrical failure and acid corrosion may result.
-

# OPERATION AND IMPORTANT RIDING POINTS

## Starting and warming up a cold engine

EAU04683

In order for the ignition circuit cut-off system to enable starting, one of the following conditions must be met:

- The transmission is in the neutral position.
- The transmission is in gear with the clutch lever pulled and the sidestand up.

EW000054

### **WARNING**

- Before starting the engine, check the function of the ignition circuit cut-off system according to the procedure described on page 3-12.
- Never ride with the sidestand down.

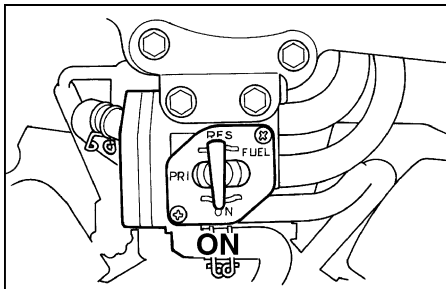

1. Turn the fuel cock lever to "ON".
2. Turn the key to "ON" and make sure that the engine stop switch is set to "RUN".
3. Shift the transmission into the neutral position.

### **NOTE:**

When the transmission is in the neutral position, the neutral indicator light should be on, otherwise have a Yamaha dealer check the electrical circuit.

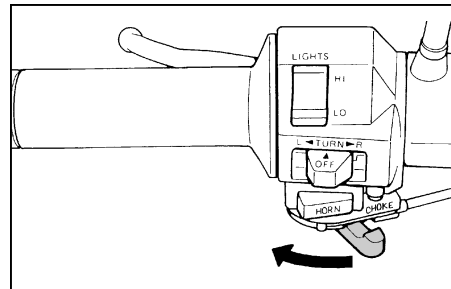

4. Turn the starter (choke) on and completely close the throttle. (See page 3-7 for starter (choke) operation.)
5. Start the engine by pushing the start switch.

### **NOTE:**

If the engine fails to start, release the start switch, wait a few seconds, and then try again. Each starting attempt should be as short as possible to preserve the battery. Do not crank the engine more than 10 seconds on any one attempt.

# OPERATION AND IMPORTANT RIDING POINTS

6. After starting the engine, move the starter (choke) back halfway.

ECA00055

## CAUTION:

**For maximum engine life, always warm the engine up before starting off. Never accelerate hard when the engine is cold!**

7. When the engine is warm, turn the starter (choke) off.

## NOTE:

The engine is warm when it responds normally to the throttle with the starter (choke) turned off. To avoid the possibility of excessive exhaust emissions, never leave the starter (choke) on longer than necessary. The time necessary for starter (choke) use depends upon the ambient temperature. Temperatures above 10 °C (50 °F) require about 7 seconds of starter (choke) use and temperatures below 10 °C (50 °F) require about 35 seconds with the starter (choke) turned on, then about 2.5 min-

utes with the starter (choke) in the half-way position.

EAU01258

## Starting a warm engine

Follow the same procedure as for starting a cold engine with the exception that the starter (choke) is not required when the engine is warm.

# OPERATION AND IMPORTANT RIDING POINTS

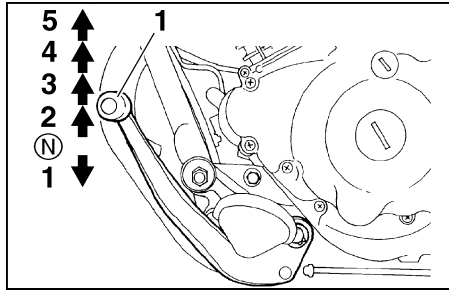

1. Shift pedal  
N. Neutral position

EAU00423

5

## Shifting

Shifting gears lets you control the amount of engine power available for starting off, accelerating, climbing hills, etc.

The gear positions are shown in the illustration.

### NOTE:

To shift the transmission into the neutral position, press the shift pedal down repeatedly until it reaches the end of its travel, and then slightly raise it.

EC000048

### CAUTION:

- Even with the transmission in the neutral position, do not coast for long periods of time with the engine off, and do not tow the motorcycle for long distances. The transmission is properly lubricated only when the engine is running. Inadequate lubrication may damage the transmission.
- Always use the clutch while changing gears to avoid damaging the engine, transmission, and drive train, which are not designed to withstand the shock of forced shifting.

EAU02988

### To start out and accelerate

1. Pull the clutch lever to disengage the clutch.
2. Shift the transmission into first gear. The neutral indicator light should go out.
3. Open the throttle gradually, and at the same time, release the clutch lever slowly.
4. At the recommended shift points shown in the table on page 5-5, close the throttle, and at the same time, quickly pull the clutch lever in.
5. Shift the transmission into second gear. (Make sure not to shift the transmission into the neutral position.)
6. Open the throttle part way and gradually release the clutch lever.
7. Follow the same procedure when shifting to the next higher gear.

### NOTE:

Always shift gears at the recommended shift points.

# OPERATION AND IMPORTANT RIDING POINTS

EAU00427

## To decelerate

1. Apply both the front and the rear brakes to slow the motorcycle.
2. Shift the transmission into first gear when the motorcycle reaches 20 km/h (12.5 mi/h). If the engine is about to stall or runs very roughly, pull the clutch lever in and use the brakes to stop the motorcycle.
3. Shift the transmission into the neutral position when the motorcycle is almost completely stopped. The neutral indicator light should come on.

EAU02974

## Recommended shift points

The recommended shift points during acceleration and deceleration are shown in the table below.

	Acceleration shift point km/h (mi/h)	Deceleration shift point km/h (mi/h)
1st → 2nd	16 (9.9)	20 (12.5)
2nd → 3rd	24 (14.9)	20 (12.5)
3rd → 4th	32 (19.9)	20 (12.5)
4th → 5th	40 (24.9)	20 (12.5)

EAU01128

## Engine break-in

There is never a more important period in the life of your engine than the period between 0 and 1,600 km (1,000 mi). For this reason, you should read the following material carefully.

Since the engine is brand new, do not put an excessive load on it for the first 1,600 km (1,000 mi). The various parts in the engine wear and polish themselves to the correct operating clearances. During this period, prolonged full-throttle operation or any condition that might result in engine overheating must be avoided.

# OPERATION AND IMPORTANT RIDING POINTS

---

---

## 0–1,000 km (0–600 mi)

EAU00452\*

Avoid prolonged operation above 1/3 throttle.

## 1,000–1,600 km (600–1,000 mi)

Avoid prolonged operation above 1/2 throttle.

## 1,600 km and beyond

The vehicle can now be operated normally.

EC000059\*

### CAUTION:

- After 1,000 km (600 mi) of operation, the engine oil must be changed, the oil filter element replaced, and the oil strainer cleaned.
  - If any engine trouble should occur during the engine break-in period, immediately have a Yamaha dealer check the vehicle.
- 

## Parking

EAU00460

When parking, stop the engine, and then remove the key from the main switch.

EW000058

### WARNING

- Since the engine and exhaust system can become very hot, park in a place where pedestrians or children are not likely to touch them.
  - Do not park on a slope or on soft ground, otherwise the motorcycle may overturn.
-

EAU01790

Safety is an obligation of the owner. Periodic inspection, adjustment and lubrication will keep your vehicle in the safest and most efficient condition possible. The most important points of motorcycle inspection, adjustment, and lubrication are explained on the following pages.

**Maintenance, replacement, or repair of the emission control devices and systems may be performed by any repair establishment or individual that is certified (if applicable).**

EW000060

**! WARNING**

**If you are not familiar with motorcycle maintenance work, have a Yamaha dealer do it for you.**

EAU00467

## PERIODIC MAINTENANCE

PROPER PERIODIC MAINTENANCE OF YOUR MOTORCYCLE IS IMPORTANT IN ORDER TO ENJOY LONG, PLEASURABLE SERVICE. ESPECIALLY IMPORTANT ARE THE MAINTENANCE SERVICES RELATED TO EMISSIONS CONTROL. THESE CONTROLS NOT ONLY FUNCTION TO ENSURE CLEANER AIR, BUT ARE ALSO VITAL TO PROPER ENGINE OPERATION AND MAXIMUM PERFORMANCE. IN THE FOLLOWING PERIODIC MAINTENANCE CHARTS, THE SERVICES RELATED TO EMISSIONS CONTROL ARE GROUPED SEPARATELY. THESE SERVICES REQUIRE SPECIALIZED DATA, KNOWLEDGE, AND EQUIPMENT. YAMAHA DEALERS ARE TRAINED AND EQUIPPED TO PERFORM THESE PARTICULAR SERVICES.



# PERIODIC MAINTENANCE AND MINOR REPAIR

---

EW000062

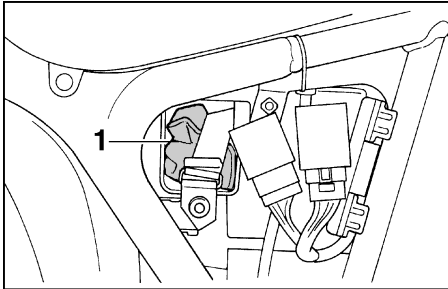

1. Owner's tool kit

## **⚠ WARNING**

Modifications not approved by Yamaha may cause loss of performance, excessive emissions, and render the vehicle unsafe for use. Consult a Yamaha dealer before attempting any changes.

EAU00468

## **Owner's tool kit**

The service information included in this manual and the tools provided in the owner's tool kit are intended to assist you in the performance of preventive maintenance and minor repairs. However, additional tools such as a torque wrench may be necessary to perform certain maintenance work correctly.

### **NOTE:**

If you do not have the tools or experience required for a particular job, have a Yamaha dealer perform it for you.

# PERIODIC MAINTENANCE AND MINOR REPAIR

EAU00471

## Periodic maintenance chart for the emission control system

No.	ITEM	ROUTINE	INITIAL	ODOMETER READINGS				
			600 mi (1,000km) or 1 month	4,000 mi (6,000km) or 6 months	7,000 mi (11,000km) or 12 months	10,000 mi (16,000km) or 18 months	13,000 mi (21,000km) or 24 months	
1	* <b>Valve clearance</b>	• Check and adjust valve clearance when engine is cold.	√	√	√	√	√	
2	<b>Spark plugs</b>	• Check condition. • Adjust gap and clean. • Replace every 7,000 mi (11,000 km) or 12 months .		√	<b>Replace.</b>	√	<b>Replace.</b>	
3	* <b>Crankcase ventilation system</b>	• Check ventilation hose for cracks or damage. • Replace if necessary.		√		√		
4	* <b>Fuel line</b>	• Check fuel hose and vacuum hose for cracks or damage. • Replace if necessary.		√	√	√	√	
5	* <b>Exhaust system</b>	• Check for leakage. • Tighten if necessary. • Replace gasket(s) if necessary.		√	√	√	√	
6	* <b>Idle speed</b>	• Check and adjust engine idle speed. • Adjust cable free play.		√	√	√	√	
7	* <b>Evaporative emission control system (for California only)</b>	• Check control system for damage. • Replace if necessary.			√		√	

\* Since these items require special tools, data and technical skills, have a Yamaha dealer perform the service.

# PERIODIC MAINTENANCE AND MINOR REPAIR

EAU00472

## General maintenance and lubrication chart

No.	ITEM	ROUTINE	TYPE	INITIAL	ODOMETER READINGS				
				600 mi (1,000km) or 1 month	4,000 mi (6,000km) or 6 months	7,000 mi (11,000km) or 12 months	10,000 mi (16,000km) or 18 months	13,000 mi (21,000km) or 24 months	
1	Engine oil	<ul style="list-style-type: none"> <li>Warm-up engine before draining.</li> </ul>	See page 8-1.	√	√	√	√	√	
2	* Engine oil filter element	<ul style="list-style-type: none"> <li>Replace.</li> </ul>	–	√		√		√	
3	* Air filter element	<ul style="list-style-type: none"> <li>Wet type filter must be washed and damped with oil.</li> </ul>	Engine oil		√	√	√	√	
4	* Brake system	<ul style="list-style-type: none"> <li>Adjust free play.</li> <li>Replace pads if necessary. (front)</li> <li>Replace shoes if necessary. (rear)</li> </ul>	–	√	√	√	√	√	
5	* Clutch	<ul style="list-style-type: none"> <li>Adjust free play.</li> </ul>	–	√	√	√	√	√	
6	Drive chain	<ul style="list-style-type: none"> <li>Check chain condition.</li> <li>Adjust and lubricate chain thoroughly.</li> </ul>	SAE 30W-50W motor oil	<b>Every 300 mi (500 km)</b>					
7	Control and meter cable	<ul style="list-style-type: none"> <li>Apply chain lube thoroughly.</li> </ul>	Yamaha Chain and Cable Lube or engine oil SAE 10W-30 (API SE)	√	√	√	√	√	
8	* Swingarm pivot shaft	<ul style="list-style-type: none"> <li>Check swingarm assembly for looseness.</li> <li>Moderately repack.</li> </ul>	Lithium-soap-based grease (all-purpose grease)	<b>Check</b>	√	√	√	√	
9	Brake and clutch lever pivot shafts	<ul style="list-style-type: none"> <li>Apply chain lube lightly.</li> </ul>	Lithium-soap-based grease (all-purpose grease)		√	√	√	√	
10	Brake and shift pedal pivot shafts	<ul style="list-style-type: none"> <li>Lubricate.</li> <li>Apply chain lube lightly.</li> </ul>	Lithium-soap-based grease (all-purpose grease)		√	√	√	√	
11	* Sidestand pivot	<ul style="list-style-type: none"> <li>Check operation and lubricate.</li> <li>Apply chain lube lightly.</li> </ul>	Lithium-soap-based grease (all-purpose grease)		√	√	√	√	

6

# PERIODIC MAINTENANCE AND MINOR REPAIR

No.	ITEM	ROUTINE	TYPE	INITIAL	ODOMETER READINGS				
				600 mi (1,000km) or 1 month	4,000 mi (6,000km) or 6 months	7,000 mi (11,000km) or 12 months	10,000 mi (16,000km) or 18 months	13,000 mi (21,000km) or 24 months	
12	* <b>Front fork</b>	• Check operation and leakage.	-		√	√	√	√	
13	* <b>Steering bearings</b>	• Check bearings assembly for looseness. • Moderately repack every 10,000 mi (16,000 km) or 18 months.	Lithium-soap-based grease (all-purpose grease)		√	√	<b>Repack.</b>	√	
14	* <b>Wheel bearings</b>	• Check bearings for smooth operation.	-		√	√	√	√	
15	<b>Battery</b>	• Check specific gravity and breather pipe for proper operation.	-		√	√	√	√	
16	* <b>Sidestand switch</b>	• Check and clean or replace if necessary.	-	√	√	√	√	√	

\* Since these items require special tools, data and technical skills, have a Yamaha dealer perform the service.

EAU03906

## NOTE:

From 16,000 mi (26,000 km) or 30 months, repeat the maintenance intervals starting from 4,000 mi (6,000 km) or 6 months.

EAU03057

## NOTE:

- The air filter needs more frequent service if you are riding in unusually wet or dusty areas.
- Hydraulic brake system
  - When disassembling the master cylinder or caliper cylinder, always replace the brake fluid. Check the brake fluid level regularly and fill as required.
  - Replace the oil seals on the inner parts of the master cylinder and caliper cylinder every two years.
  - Replace the brake hoses every four years or if cracked or damaged.

# PERIODIC MAINTENANCE AND MINOR REPAIR

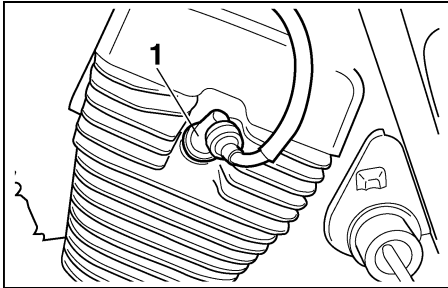

1. Spark plug cap

EAU03329

## Checking the spark plugs

The spark plugs are important engine components, which are easy to check. Since heat and deposits will cause any spark plug to slowly erode, the spark plugs should be removed and checked in accordance with the periodic maintenance and lubrication chart. In addition, the condition of the spark plugs can reveal the condition of the engine.

### To remove a spark plug

1. Remove the spark plug cap.

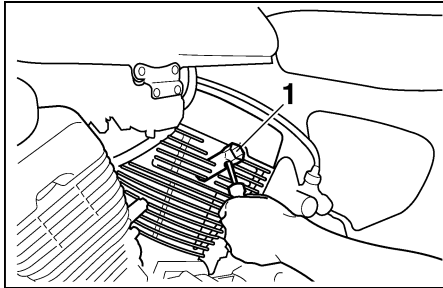

1. Spark plug wrench

2. Remove the spark plug as shown, with the spark plug wrench included in the owner's tool kit.

### To check the spark plugs

1. Check that the porcelain insulator around the center electrode on each spark plug is a medium-to-light tan (the ideal color when the motorcycle is ridden normally).
2. Check that all spark plugs installed in the engine have the same color.

### NOTE:

If any spark plug shows a distinctly different color, the engine could be defective. Do not attempt to diagnose such problems yourself. Instead, have a Yamaha dealer check the motorcycle.

3. Check each spark plug for electrode erosion and excessive carbon or other deposits, and replace it if necessary.

Specified spark plug:  
C6HSA (NGK) or  
U20FS-U (DENSO)

# PERIODIC MAINTENANCE AND MINOR REPAIR

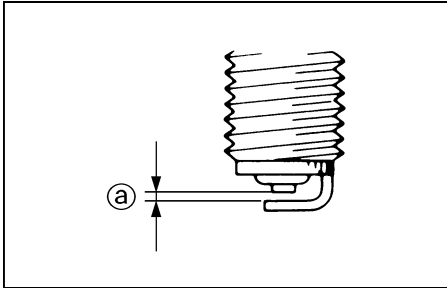

a. Spark plug gap

## To install a spark plug

1. Measure the spark plug gap with a wire thickness gauge and, if necessary, adjust the gap to specification.

Spark plug gap:  
0.6–0.7 mm (0.02–0.03 in)

2. Clean the surface of the spark plug gasket and its mating surface, and then wipe off any grime from the spark plug threads.
3. Install the spark plug with the spark plug wrench, and then tighten it to the specified torque.

Tightening torque:

Spark plug:

12.5 Nm (1.25 m·kgf, 9.0 ft·lbf)

## NOTE: \_\_\_\_\_

If a torque wrench is not available when installing a spark plug, a good estimate of the correct torque is 1/4–1/2 turn past finger tight. However, the spark plug should be tightened to the specified torque as soon as possible.

4. Install the spark plug cap.

# PERIODIC MAINTENANCE AND MINOR REPAIR

EAU00499

## Canister (for California only)

This model is equipped with a canister to prevent the discharging of fuel vapor into the atmosphere. Before operating this motorcycle, make sure to check the following:

- Check each hose connection.
- Check each hose and canister for cracks or damage. Replace if damaged.
- Make sure that the canister breather is not blocked, and if necessary, clean it.

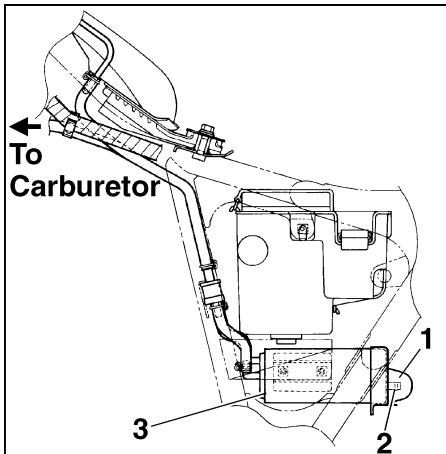

1. Canister cover
2. Canister breather
3. Canister

EAU04613

## Engine oil and oil filter element

The engine oil level should be checked before each ride. In addition, the oil must be changed and the oil filter element replaced at the intervals specified in the periodic maintenance and lubrication chart.

### To check the engine oil level

1. Place the motorcycle on a level surface and hold it in an upright position.

**NOTE:** \_\_\_\_\_  
Make sure that the motorcycle is positioned straight up when checking the oil level. A slight tilt to the side can result in a false reading.  
\_\_\_\_\_

# PERIODIC MAINTENANCE AND MINOR REPAIR

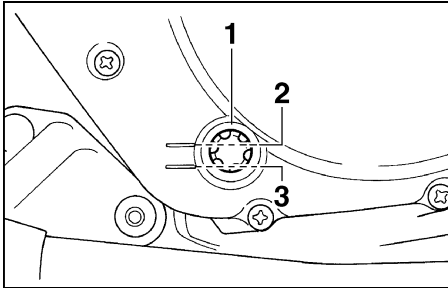

1. Engine oil level check window
2. Maximum level mark
3. Minimum level mark

2. Start the engine, warm it up for several minutes, and then turn it off.
3. Wait a few minutes until the oil settles, and then check the oil level through the check window located at the bottom-right side of the crankcase.

**NOTE:** \_\_\_\_\_  
The engine oil should be between the minimum and maximum level marks.

4. If the engine oil is below the minimum level mark, add sufficient oil of the recommended type to raise it to the correct level.

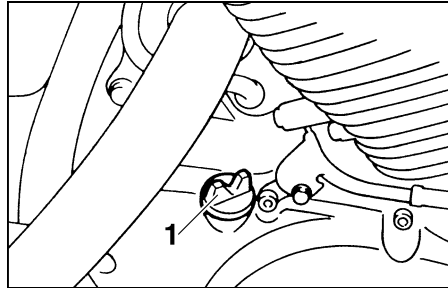

1. Engine oil filler cap

## To change the engine oil (with or without oil filter element replacement)

1. Start the engine, warm it up for several minutes, and then turn it off.
2. Place an oil pan under the engine to collect the used oil.

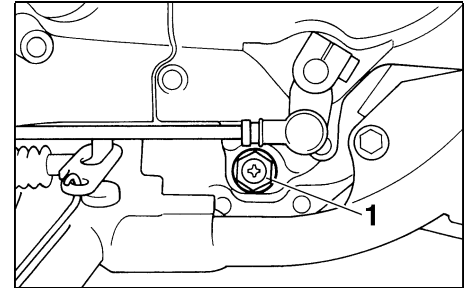

1. Engine oil drain bolt

3. Remove the engine oil filler cap and drain bolt to drain the oil from the crankcase.

**NOTE:** \_\_\_\_\_  
Skip steps 4–6 if the oil filter element is not being replaced.



# PERIODIC MAINTENANCE AND MINOR REPAIR

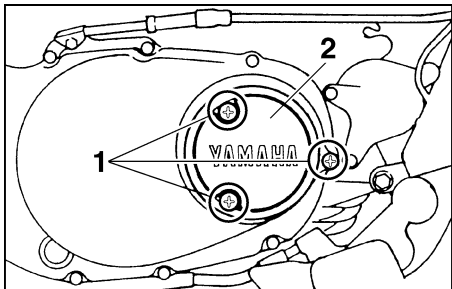

1. Bolt ( $\times 3$ )
2. Oil filter element cover

4. Remove the oil filter element cover by removing the bolts.
5. Remove and replace the oil filter element and O-ring.
6. Install the oil filter element cover by installing the bolts, then tightening them to the specified torque.

#### Tightening torque:

Oil filter element cover bolt:  
7 Nm (0.7 m·kgf, 5.1 ft·lbf)

#### NOTE:

Make sure that the O-ring is properly seated.

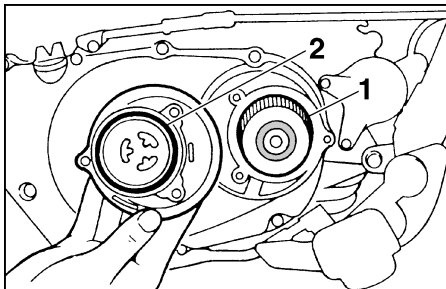

1. Oil filter element
2. O-ring

7. Install the engine oil drain bolt, and then tighten it to the specified torque.

#### Tightening torque:

Engine oil drain bolt:  
34 Nm (3.4 m·kgf, 25 ft·lbf)

8. Add the specified amount of the recommended engine oil, and then install and tighten the oil filler cap.

Recommended engine oil:

See page 8-1.

Oil quantity:

With oil filter element replacement:

1.6 L (1.4 Imp qt, 1.7 US qt)

Without oil filter element replacement:

1.4 L (1.2 Imp qt, 1.5 US qt)

Total amount (dry engine):

1.8 L (1.6 Imp qt, 1.9 US qt)

ECA00133

#### CAUTION:

- In order to prevent clutch slippage (since the engine oil also lubricates the clutch), do not mix any chemical additives. Do not use oils with a diesel specification of "CD" or oils of a higher quality than specified. In addition, do not use oils labeled "ENERGY CONSERVING II" or higher.
- Make sure that no foreign material enters the crankcase.

# PERIODIC MAINTENANCE AND MINOR REPAIR

9. Start the engine, and then let it idle for several minutes while checking it for oil leakage. If oil is leaking, immediately turn the engine off and check for the cause.
10. Turn the engine off, and then check the oil level and correct it if necessary.

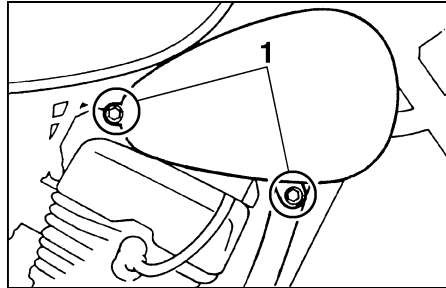

1. Bolt (x 2)

EAU04182\*

## Cleaning the air filter element

The air filter element should be cleaned at the intervals specified in the periodic maintenance and lubrication chart. Clean the air filter element more frequently if you are riding in unusually wet or dusty areas.

1. Remove the air filter case cover by removing the bolts and loosening the clamp screw.

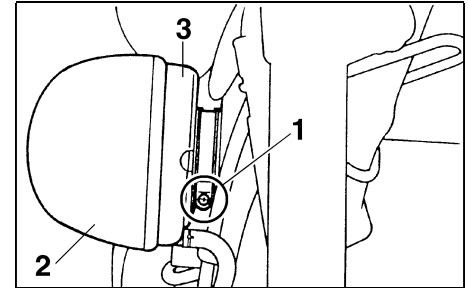

1. Clamp screw
2. Air filter case cover
3. Air filter case

# PERIODIC MAINTENANCE AND MINOR REPAIR

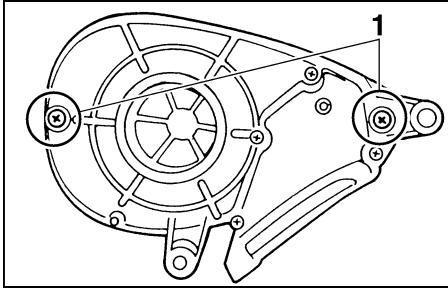

1. Screw (× 2)
2. Remove the air filter element cover by removing the screws.

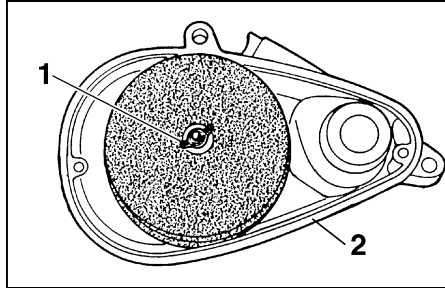

1. Wing nut
2. Air filter case
3. Remove the air filter element by removing the wing nut.

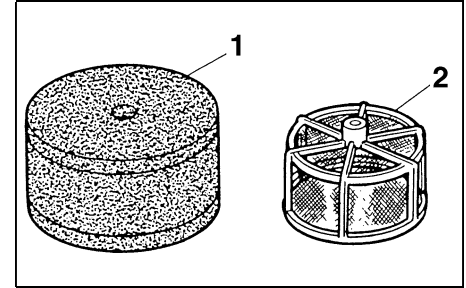

1. Sponge material
2. Air filter element frame
4. Remove the sponge material from the air filter element frame, clean it with solvent, and then squeeze the remaining solvent out.
5. Apply oil of the recommended type to the entire surface of the sponge material, and then squeeze the excess oil out.

**NOTE:** \_\_\_\_\_  
The air filter element should be wet but not dripping.

Recommended oil:  
Engine oil

# PERIODIC MAINTENANCE AND MINOR REPAIR

- Pull the sponge material over the air filter element frame.
- Insert the element into the air filter case, and then tighten the wing nut.

EC000082\*

## CAUTION:

- **Make sure that the air filter element is properly seated in the air filter case.**
  - **The engine should never be operated without the air filter element installed, otherwise the pistons and/or cylinders may become excessively worn.**
- 
- Install the air filter element cover by installing the screws.
  - Install the air filter case cover by installing the bolts.
  - Tighten the clamp screw.

## Adjusting the carburetor

EAU01762

The carburetor is an important part of the engine and its emission control system, which requires very sophisticated adjustment. Therefore, carburetor adjustments should be left to Yamaha dealer, who has the necessary professional knowledge and experience.

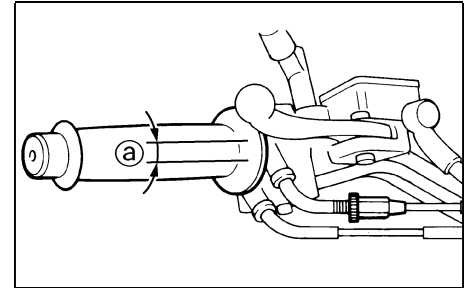

a. Throttle cable free play

## Adjusting the throttle cable free play

EAU00635

The throttle cable free play should measure 3–5 mm (0.12–0.20 in) at the throttle grip. Periodically check the throttle cable free play and, if necessary, have a Yamaha dealer adjust it.

# PERIODIC MAINTENANCE AND MINOR REPAIR

EAU00637

## Adjusting the valve clearance

The valve clearance changes with use, resulting in improper air-fuel mixture and/or engine noise. To prevent this from occurring, the valve clearance must be adjusted by a Yamaha dealer at the intervals specified in the periodic maintenance and lubrication chart.

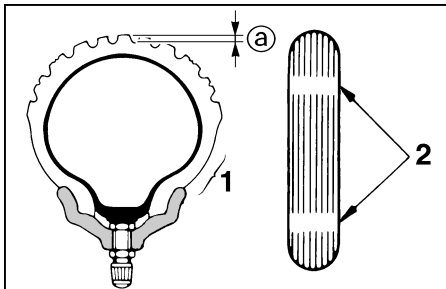

1. Sidewall
2. Tire wear indicator
- a. Tire tread depth

EAU03360

## Tires

To maximize the performance, durability, and safe operation of your motorcycle, note the following points regarding the specified tires.

### Tire air pressure

The tire air pressure should be checked and, if necessary, adjusted before each ride.

EW000082

## ⚠ WARNING

- The tire air pressure must be checked and adjusted on cold tires (i.e., when the temperature of the tires equals the ambient temperature).
- The tire air pressure must be adjusted in accordance with the riding speed and with the total weight of rider, passenger, cargo, and accessories approved for this model.

Tire air pressure (measured on cold tires)		
Load*	Front	Rear
Up to 90 kg (198 lb)	175 kPa (1.75 kgf/cm <sup>2</sup> , 25 psi)	200 kPa (2.00 kgf/cm <sup>2</sup> , 29 psi)
90 kg (198 lb)– maximum	200 kPa (2.00 kgf/cm <sup>2</sup> , 29 psi)	225 kPa (2.25 kgf/cm <sup>2</sup> , 33 psi)

Maximum load*	XV250: 196 kg (432 lb) XV250C: 195 kg (430 lb)
---------------	---

\* Total weight of rider, passenger, cargo and accessories

# PERIODIC MAINTENANCE AND MINOR REPAIR

EW000083

## **WARNING**

Proper loading of your motorcycle is important for several characteristics of your motorcycle, such as handling, braking, performance and safety. Do not carry loosely packed items that can shift. Securely pack your heaviest items close to the center of the motorcycle, and distribute the weight evenly from side to side. Properly adjust the suspension for your load, and check the condition and pressure of your tires. **NEVER OVERLOAD YOUR MOTORCYCLE.** Make sure the total weight of the cargo, rider, passenger, and accessories (cowling, saddlebags, etc. if approved for this model) does not exceed the maximum load of the motorcycle. Operation of an overloaded motorcycle could cause tire damage, an accident, or even injury.

## Tire inspection

Always check the tires before operating the motorcycle. If a tire tread shows crosswise lines (minimum tread depth), if the tire has a nail or glass fragments in it, or if the sidewall is cracked, contact a Yamaha dealer immediately and have the tire replaced.

### FRONT

Manufacturer	Size	Model
CHENG SHIN	3.00-18 47P	C-916

### REAR

Manufacturer	Size	Model
CHENG SHIN	130/90-15M/C 66P	C-915

Minimum tire tread depth (front and rear)	1.0 mm (0.04 in)
---	------------------

EAU00680

## **WARNING**

- It is dangerous to ride with a worn-out tire. When a tire tread begins to show crosswise lines, have a Yamaha dealer replace the tire immediately.
- The replacement of all wheel- and brake-related parts, including the tires, should be left to a Yamaha dealer, who has the necessary professional knowledge and experience.
- It is not recommended to patch a punctured tube. If unavoidable, however, patch the tube very carefully and replace it as soon as possible with a high-quality product.

# PERIODIC MAINTENANCE AND MINOR REPAIR

---

---

## Spoke wheels

EAU00685

To maximize the performance, durability, and safe operation of your motorcycle, note the following points regarding the specified wheels.

- The wheel rims should be checked for cracks, bends or warpage, and the spokes for looseness or damage before each ride. If any damage is found, have a Yamaha dealer replace the wheel. Do not attempt even the smallest repair to the wheel. A deformed or cracked wheel must be replaced.
- The wheel should be balanced whenever either the tire or wheel has been changed or replaced. An unbalanced wheel can result in poor performance, adverse handling characteristics, and a shortened tire life.
- Ride at moderate speeds after changing a tire since the tire surface must first be “broken in” for it to develop its optimal characteristics.

## Accessories and replacement parts

EAU00691

EW000098



**This motorcycle is not designed to pull a trailer or to be attached to a sidecar. The accessories or replacement parts you choose for your motorcycle should be designed specifically for this model, and they must be securely mounted to maintain the inherent stability of the original design. Genuine Yamaha Parts and Accessories are designed and tested to be compatible with your motorcycle. Please consider Genuine Yamaha Parts and Accessories before making a purchase. Use of non-Yamaha-approved accessories or replacement parts may cause loss of handling stability and riding safety. Since Yamaha cannot control the quality of accessories or parts manufactured by other companies, Yamaha cannot be held lia-**

**ble for any consequences caused by the use of items which have not been approved by Yamaha.**

---

# PERIODIC MAINTENANCE AND MINOR REPAIR

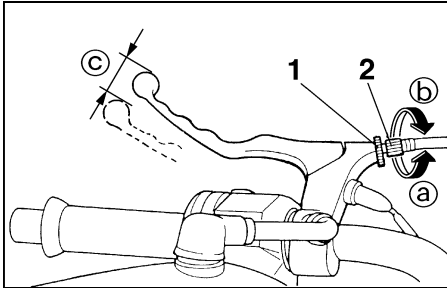

1. Locknut
2. Clutch lever free play adjusting bolt
- c. Clutch lever free play

EAU00694

## Adjusting the clutch lever free play

The clutch lever free play should measure 10–15 mm (0.4–0.6 in) as shown. Periodically check the clutch lever free play and, if necessary, adjust it as follows.

1. Loosen the locknut at the clutch lever.
2. To increase the clutch lever free play, turn the adjusting bolt in direction (a). To decrease the clutch lever free play, turn the adjusting bolt in direction (b).

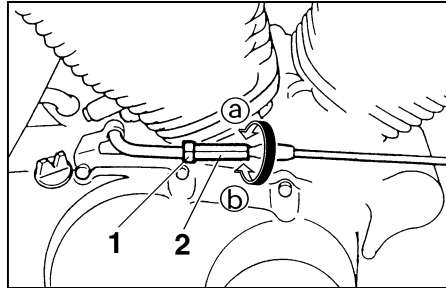

1. Locknut
2. Clutch lever free play adjusting nut

3. If the specified clutch lever free play could be obtained as described above, tighten the locknut and skip the rest of the procedure, otherwise proceed as follows.
4. Fully turn the adjusting bolt at the clutch lever in direction (a) to loosen the clutch cable.
5. Loosen the locknut at the crankcase.
6. To increase the clutch lever free play, turn the adjusting nut in direction (a). To decrease the clutch lever free play, turn the adjusting nut in direction (b).

7. Tighten the locknut at the clutch lever and the crankcase.



# PERIODIC MAINTENANCE AND MINOR REPAIR

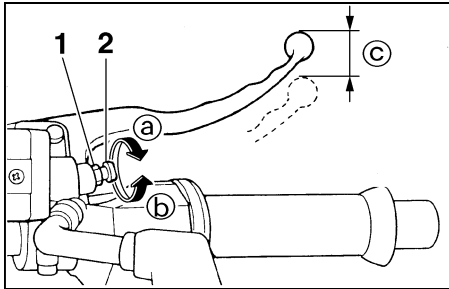

1. Locknut
2. Brake lever free play adjusting bolt
- c. Brake lever free play

EAU00696

## Adjusting the brake lever free play

The brake lever free play should measure 2–5 mm (0.08–0.20 in) as shown. Periodically check the brake lever free play and, if necessary, adjust it as follows.

1. Loosen the locknut at the brake lever.
2. To increase the brake lever free play, turn the adjusting bolt in direction (a). To decrease the brake lever free play, turn the adjusting bolt in direction (b).
3. Tighten the locknut.

EW000099

### **⚠ WARNING**

- After adjusting the brake lever free play, check the free play and make sure that the brake is working properly.
- A soft or spongy feeling in the brake lever can indicate the presence of air in the hydraulic system. If there is air in the hydraulic system, have a Yamaha dealer bleed the system before operating the motorcycle. Air in the hydraulic system will diminish the braking performance, which may result in loss of control and an accident.

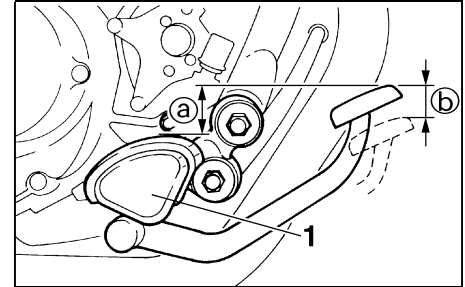

1. Footrest
- a. Distance between brake pedal and footrest
- b. Brake pedal free play

EAU03778

## Adjusting the brake pedal position and free play

EW000104

### **⚠ WARNING**

It is advisable to have a Yamaha dealer make these adjustments.

### Brake pedal position

The top of the brake pedal should be positioned approximately 60 mm (2.4 in) above the top of the footrest as shown. Periodically check the brake pedal position and, if necessary, adjust it as follows.

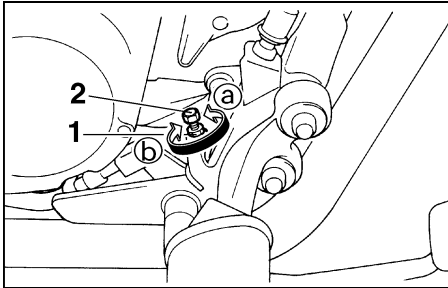

1. Locknut
2. Brake pedal position adjusting bolt

1. Loosen the locknut at the brake pedal.
2. To raise the brake pedal, turn the adjusting bolt in direction Ⓐ. To lower the brake pedal, turn the adjusting bolt in direction Ⓑ.
3. Tighten the locknut.

EWA00044

## **⚠ WARNING**

**After adjusting the brake pedal position, the brake pedal free play must be adjusted.**

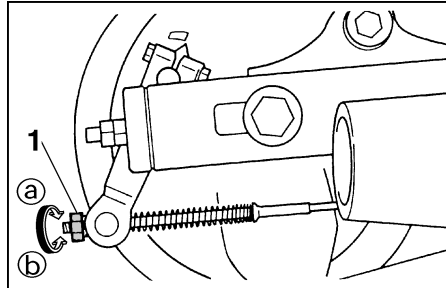

1. Brake pedal free play adjusting nut

## **Brake pedal free play**

The brake pedal free play should measure 20–30 mm (0.8–1.2 in) at the brake pedal end. Periodically check the brake pedal free play and, if necessary, adjust it as follows.

To increase the brake pedal free play, turn the adjusting nut at the brake rod in direction Ⓐ. To decrease the brake pedal free play, turn the adjusting nut in direction Ⓑ.

## **⚠ WARNING**

- After adjusting the drive chain slack or removing and installing the rear wheel, always check the brake pedal free play.
- If proper adjustment cannot be obtained as described, have a Yamaha dealer make this adjustment.
- After adjusting the brake pedal free play, check the operation of the brake light.

# PERIODIC MAINTENANCE AND MINOR REPAIR

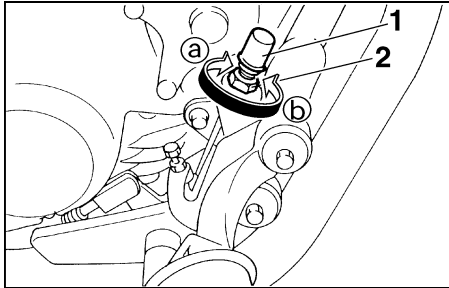

1. Rear brake light switch
2. Rear brake light switch adjusting nut

EAU00713

## Adjusting the rear brake light switch

The rear brake light switch, which is activated by the brake pedal, is properly adjusted when the brake light comes on just before braking takes effect. If necessary, adjust the brake light switch as follows.

Turn the adjusting nut while holding the rear brake light switch in place. To make the brake light come on earlier, turn the adjusting nut in direction ①. To make the brake light come on later, turn the adjusting nut in direction ②.

EAU00720

## Checking the front brake pads and rear brake shoes

The front brake pads and the rear brake shoes must be checked for wear at the intervals specified in the periodic maintenance and lubrication chart.

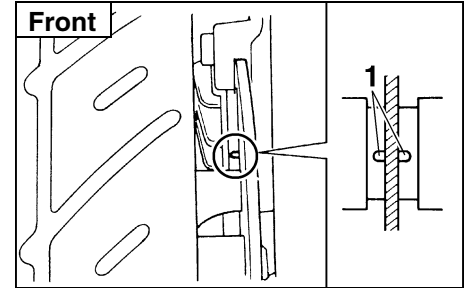

1. Brake pad wear indicator groove

EAU00725

## Front brake pads

Each front brake pad is provided with a wear indicator groove, which allows you to check the brake pad wear without having to disassemble the brake. To check the brake pad wear, check the wear indicator groove. If a brake pad has worn to the point that the wear indicator groove has almost disappeared, have a Yamaha dealer replace the brake pads as a set.

# PERIODIC MAINTENANCE AND MINOR REPAIR

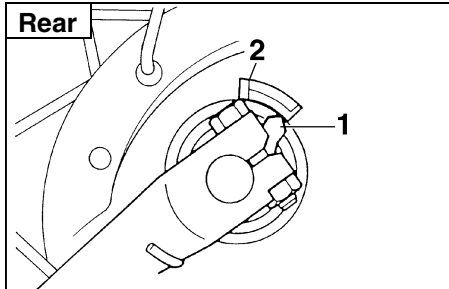

1. Brake shoe wear indicator
2. Brake shoe wear limit line

EAU04502

## Rear brake shoes

The rear brake is provided with a wear indicator, which allows you to check the brake shoe wear without having to disassemble the brake. To check the brake shoe wear, check the position of the wear indicator while applying the brake. If a brake shoe has worn to the point that the wear indicator reaches the wear limit line, have a Yamaha dealer replace the brake shoes as a set.

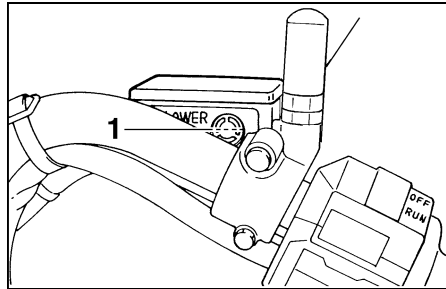

1. Minimum level mark

EAU04856

## Checking the brake fluid level

Insufficient brake fluid may allow air to enter the brake system, possibly causing it to become ineffective.

Before riding, check that the brake fluid is above the minimum level mark and replenish if necessary. A low brake fluid level may indicate worn brake pads and/or brake system leakage. If the brake fluid level is low, be sure to check the brake pads for wear and the brake system for leakage.

Observe these precautions:

- When checking the fluid level, make sure that the top of the brake fluid reservoir is level.
- Use only the recommended quality brake fluid, otherwise the rubber seals may deteriorate, causing leakage and poor braking performance.

Recommended brake fluid: DOT 4

- Refill with the same type of brake fluid. Mixing fluids may result in a harmful chemical reaction and lead to poor braking performance.
- Be careful that water does not enter the brake fluid reservoir when refilling. Water will significantly lower the boiling point of the fluid and may result in vapor lock.

# PERIODIC MAINTENANCE AND MINOR REPAIR

- Brake fluid may deteriorate painted surfaces or plastic parts. Always clean up spilled fluid immediately.
- As the brake pads wear, it is normal for the brake fluid level to gradually go down. However, if the brake fluid level goes down suddenly, have a Yamaha dealer check the cause.

## Changing the brake fluid

EAU03985

Have a Yamaha dealer change the brake fluid at the intervals specified in the NOTE after the periodic maintenance and lubrication chart. In addition, have the oil seals of the brake master cylinder and caliper as well as the brake hose replaced at the intervals listed below or whenever they are damaged or leaking.

- Oil seals: Replace every two years.
- Brake hose: Replace every four years.

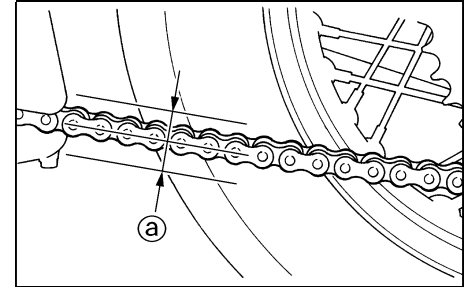

a. Drive chain slack

EAU00744

## Drive chain slack

The drive chain slack should be checked before each ride and adjusted if necessary.

### To check the drive chain slack

1. Place the motorcycle on a level surface and hold it in an upright position.

### NOTE: \_\_\_\_\_

When checking and adjusting the drive chain slack, the motorcycle should be positioned straight up and there should be no weight on it.

---

# PERIODIC MAINTENANCE AND MINOR REPAIR

2. Shift the transmission into the neutral position.
3. Move the rear wheel by pushing the motorcycle to locate the tightest portion of the drive chain, and then measure the drive chain slack as shown.

Drive chain slack:  
30–40 mm (1.2–1.6 in)

4. If the drive chain slack is incorrect, adjust it as follows.

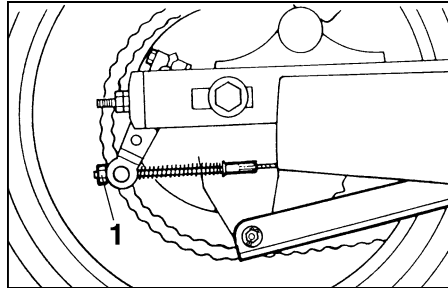

1. Brake pedal free play adjusting nut

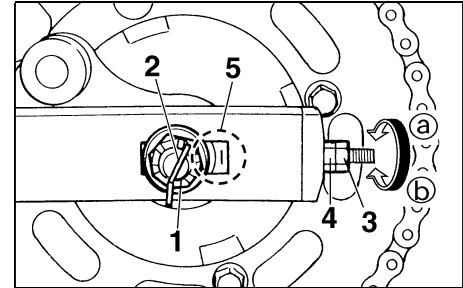

1. Axle nut
2. Cotter pin
3. Chain puller locknut
4. Drive chain slack adjusting nut
5. Alignment marks

## To adjust the drive chain slack

EAU01076

1. Loosen the brake pedal free play adjusting nut.

2. Remove the cotter pin from the axle nut, and then loosen the axle nut.
3. Loosen the chain puller locknut at each end of the swingarm.
4. To tighten the drive chain, turn the adjusting nut at each end of the swingarm in direction Ⓐ. To loosen the drive chain, turn the adjusting nut at each end of the swingarm in direction Ⓑ, and then push the rear wheel forward.

# PERIODIC MAINTENANCE AND MINOR REPAIR

**NOTE:** Using the alignment marks on each side of the swingarm, make sure that both chain pullers are in the same position for proper wheel alignment.

EC000096

**CAUTION:** Improper drive chain slack will overload the engine as well as other vital parts of the motorcycle and can lead to chain slippage or breakage. To prevent this from occurring, keep the drive chain slack within the specified limits.

5. Tighten the locknuts, and then tighten the axle nut to the specified torque.

Tightening torque:

Axle nut:

104 Nm (10.4 m·kgf, 75 ft·lbf)

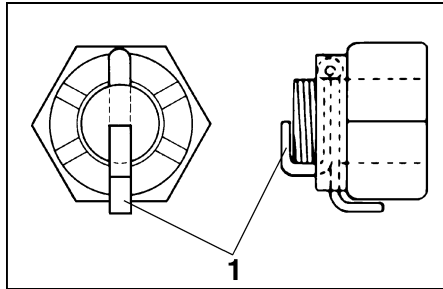

1. Cotter pin

6. Insert a new cotter pin into the axle nut, and then bend its ends as shown.

**NOTE:** Make sure that two notches in the axle nut are aligned with the hole through the wheel axle, otherwise further tighten the axle nut until they are.

EW000110

**WARNING** Always use a new cotter pin for the axle nut.

7. Adjust the brake pedal free play. (See page 6-19 for brake pedal free play adjustment procedures.)

EW000103

**WARNING** After adjusting the brake pedal free play, check the operation of the brake light.

# PERIODIC MAINTENANCE AND MINOR REPAIR

## Lubricating the drive chain

EAU03006

The drive chain must be cleaned and lubricated at the intervals specified in the periodic maintenance and lubrication chart, otherwise it will quickly wear out, especially when riding in dusty or wet areas. Service the drive chain as follows.

EC000097

### CAUTION:

**The drive chain must be lubricated after washing the motorcycle or riding in the rain.**

1. Clean the drive chain with kerosene and a small soft brush.

ECA00053

### CAUTION:

**To prevent damaging the O-rings, do not clean the drive chain with steam cleaners, high-pressure washers or inappropriate solvents.**

2. Wipe the drive chain dry.
3. Thoroughly lubricate the drive chain with a special O-ring chain lubricant.

### CAUTION:

**Do not use engine oil or any other lubricants for the drive chain, as they may contain substances that could damage the O-rings.**

ECA00052

## Checking and lubricating the cables

EAU03297

The operation of all control cables and the condition of the cables should be checked before each ride, and the cables and cable ends should be lubricated if necessary. If a cable is damaged or does not move smoothly, have a Yamaha dealer check or replace it.

Recommended lubricant:

Yamaha Chain and Cable Lube  
or engine oil SAE 10W-30  
(API SE)

EW000111

### WARNING

**Damage to the outer housing of cables may result in internal rusting and cause interference with cable movement. Replace damaged cables as soon as possible to prevent unsafe conditions.**



# PERIODIC MAINTENANCE AND MINOR REPAIR

---

---

## Checking and lubricating the throttle grip and cable

EAU04034

The operation of the throttle grip should be checked before each ride. In addition, the cable should be lubricated or replaced at the intervals specified in the periodic maintenance chart.

## Checking and lubricating the brake and shift pedals

EAU03370

The operation of the brake and shift pedals should be checked before each ride, and the pedal pivots should be lubricated if necessary.

Recommended lubricant:  
Lithium-soap-based grease  
(all-purpose grease)

## Checking and lubricating the brake and clutch levers

EAU03164

The operation of the brake and clutch levers should be checked before each ride, and the lever pivots should be lubricated if necessary.

Recommended lubricant:  
Lithium-soap-based grease  
(all-purpose grease)

# PERIODIC MAINTENANCE AND MINOR REPAIR

## Checking and lubricating the sidestand

EAU03165

The operation of the sidestand should be checked before each ride, and the sidestand pivot and metal-to-metal contact surfaces should be lubricated if necessary.

EW000113

### **! WARNING**

If the sidestand does not move up and down smoothly, have a Yamaha dealer check or repair it.

Recommended lubricant:  
Lithium-soap-based grease  
(all-purpose grease)

## Checking the front fork

EAU02939

The condition and operation of the front fork must be checked as follows at the intervals specified in the periodic maintenance and lubrication chart.

### To check the condition

### **! WARNING**

Securely support the motorcycle so that there is no danger of it falling over.

Check the inner tubes for scratches, damage and excessive oil leakage.

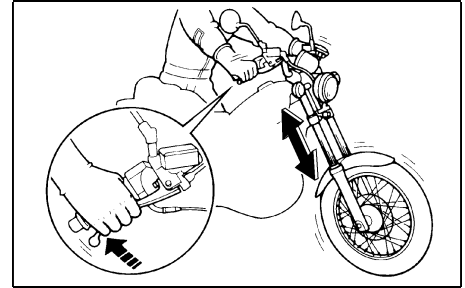

EW000115

### To check the operation

1. Place the motorcycle on a level surface and hold it in an upright position.
2. While applying the front brake, push down hard on the handlebars several times to check if the front fork compresses and rebounds smoothly.

EC000098

### **CAUTION:**

If any damage is found or the front fork does not operate smoothly, have a Yamaha dealer check or repair it.

# PERIODIC MAINTENANCE AND MINOR REPAIR

## Checking the steering

EAU00794

Worn or loose steering bearings may cause danger. Therefore, the operation of the steering must be checked as follows at the intervals specified in the periodic maintenance and lubrication chart.

1. Place a stand under the engine to raise the front wheel off the ground.

EW000115

### **WARNING**

**Securely support the motorcycle so that there is no danger of it falling over.**

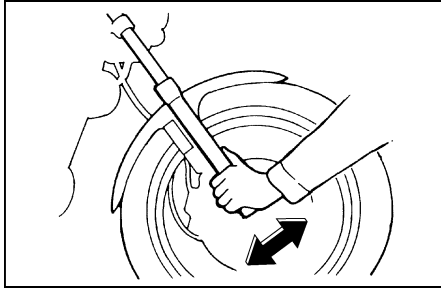

2. Hold the lower ends of the front fork legs and try to move them forward and backward. If any free play can be felt, have a Yamaha dealer check or repair the steering.

## Checking the wheel bearings

EAU01144

The front and rear wheel bearings must be checked at the intervals specified in the periodic maintenance and lubrication chart. If there is play in the wheel hub or if the wheel does not turn smoothly, have a Yamaha dealer check the wheel bearings.

# PERIODIC MAINTENANCE AND MINOR REPAIR

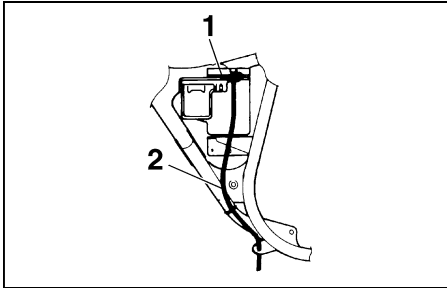

1. Battery
2. Battery breather hose

EAU01071

## Battery

A poorly maintained battery will corrode and discharge quickly. The electrolyte level, battery lead connections and breather hose routing should be checked before each ride and at the intervals specified in the periodic maintenance and lubrication chart.

### To check the electrolyte level

1. Place the motorcycle on a level surface and hold it in an upright position.

**NOTE:** \_\_\_\_\_  
Make sure that the motorcycle is positioned straight up when checking the electrolyte level.

2. Check the electrolyte level in the battery.

**NOTE:** \_\_\_\_\_  
The electrolyte should be between the minimum and maximum level marks.

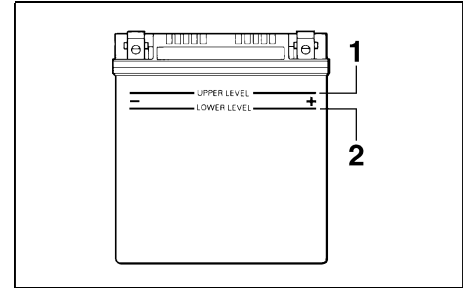

1. Maximum level mark
2. Minimum level mark

3. If the electrolyte is at or below the minimum level mark, add distilled water to raise it to the maximum level mark.

# PERIODIC MAINTENANCE AND MINOR REPAIR

EW000117

## **⚠ WARNING**

- **Electrolyte is poisonous and dangerous since it contains sulfuric acid, which causes severe burns. Avoid any contact with skin, eyes or clothing and always shield your eyes when working near batteries. In case of contact, administer the following FIRST AID.**
  - **EXTERNAL:** Flush with plenty of water.
  - **INTERNAL:** Drink large quantities of water or milk and immediately call a physician.
  - **EYES:** Flush with water for 15 minutes and seek prompt medical attention.
- **Batteries produce explosive hydrogen gas. Therefore, keep sparks, flames, cigarettes, etc., away from the battery and provide sufficient ventilation when charging it in an enclosed space.**

- **Take care not to spill electrolyte on the drive chain, as this may weaken it, shorten chain life and possibly result in an accident.**
- **KEEP THIS AND ALL BATTERIES OUT OF THE REACH OF CHILDREN.**

EC000100

## **CAUTION:**

**Use only distilled water, as tap water contains minerals that are harmful to the battery.**

4. Check and, if necessary, tighten the battery lead connections and correct the breather hose routing.

## **To store the battery**

1. If the motorcycle will not be used for more than one month, remove the battery, fully charge it, and then place it in a cool, dry place.
2. If the battery will be stored for more than two months, check the specific gravity of the electrolyte at least once a month and fully charge the battery whenever necessary.
3. Fully charge the battery before installation.
4. After installation, make sure that the battery leads are properly connected to the battery terminals and that the breather hose is properly routed, in good condition, and not obstructed.

# PERIODIC MAINTENANCE AND MINOR REPAIR

EC000099

## CAUTION:

If the breather hose is positioned in such a way that the frame is exposed to electrolyte or gas expelled from the battery, the frame could suffer structural and external damages.

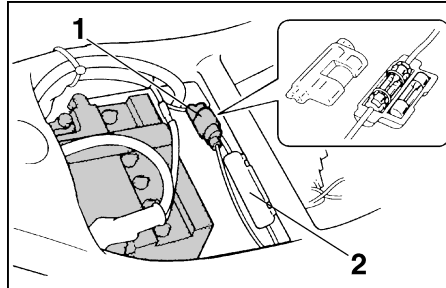

1. Main fuse
2. Signaling system fuse

EAU04201

## Replacing the fuses

The main fuse and the signaling system fuse holders are located under the rider seat. (See page 3-8 for rider seat removal and installation procedures.) If a fuse is blown, replace it as follows.

1. Turn the key to "OFF" and turn off the electrical circuit in question.
2. Remove the blown fuse, and then install a new fuse of the specified amperage.

Specified fuses:

Main fuse:	20 A
Signaling system fuse:	10 A

EC000103

## CAUTION:

Do not use a fuse of a higher amperage rating than recommended to avoid causing extensive damage to the electrical system and possibly a fire.

3. Turn the key to "ON" and turn on the electrical circuit in question to check if the device operates.
4. If the fuse immediately blows again, have a Yamaha dealer check the electrical system.

# PERIODIC MAINTENANCE AND MINOR REPAIR

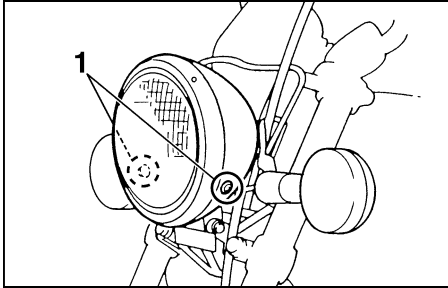

1. Screw (× 2)

EAU04187

## Replacing the headlight bulb

This motorcycle is equipped with a quartz bulb headlight. If the headlight bulb burns out, replace it as follows.

1. Remove the headlight unit by removing the screws.

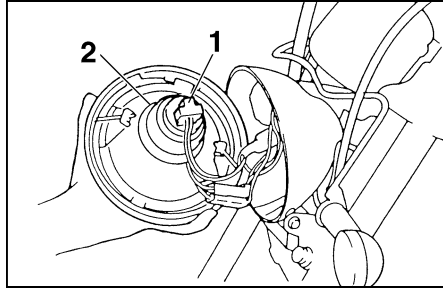

1. Headlight coupler
  2. Headlight bulb cover
2. Disconnect the headlight coupler, and then remove the bulb cover.

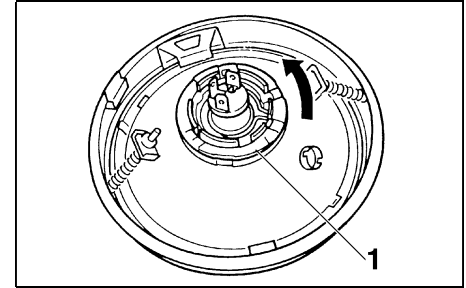

1. Headlight bulb holder
3. Remove the headlight bulb holder by turning it counterclockwise, and then remove the defective bulb.

EW000119

### **WARNING**

**Headlight bulbs get very hot. Therefore, keep flammable products away from a lit headlight bulb, and do not touch the bulb until it has cooled down.**

4. Place a new headlight bulb into position, and then secure it with the bulb holder.

# PERIODIC MAINTENANCE AND MINOR REPAIR

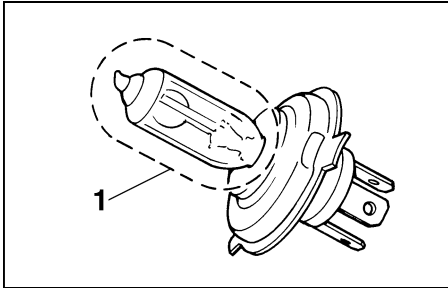

1. Do not touch the glass part of the bulb.

EC000105

## CAUTION:

**Do not touch the glass part of the headlight bulb to keep it free from oil, otherwise the transparency of the glass, the luminosity of the bulb, and the bulb life will be adversely affected. Thoroughly clean off any dirt and fingerprints on the headlight bulb using a cloth moistened with alcohol or thinner.**

5. Install the headlight bulb cover, and then connect the coupler.
6. Install the headlight unit by installing the screws.
7. Have a Yamaha dealer adjust the headlight beam if necessary.

EAU01579

## Supporting the motorcycle

Since this model is not equipped with a centerstand, follow these precautions when removing the front and rear wheel or performing other maintenance requiring the motorcycle to stand upright. Check that the motorcycle is in a stable and level position before starting any maintenance. A strong wooden box can be placed under the engine for added stability.

## To service the front wheel

1. Stabilize the rear of the motorcycle by using a motorcycle stand or, if an additional motorcycle stand is not available, by placing a jack under the frame in front of the rear wheel.
2. Raise the front wheel off the ground by using a motorcycle stand.

## To service the rear wheel

Raise the rear wheel off the ground by using a motorcycle stand or, if a motorcycle stand is not available, by placing a jack either under each side of the frame in front of the rear wheel or under each side of the swingarm.



# PERIODIC MAINTENANCE AND MINOR REPAIR

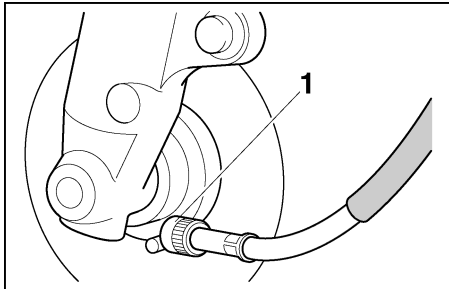

1. Speedometer cable

EAU03239

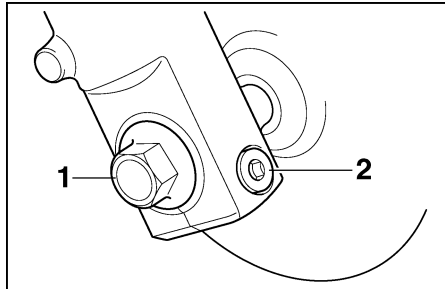

1. Wheel axle  
2. Front wheel axle pinch bolt

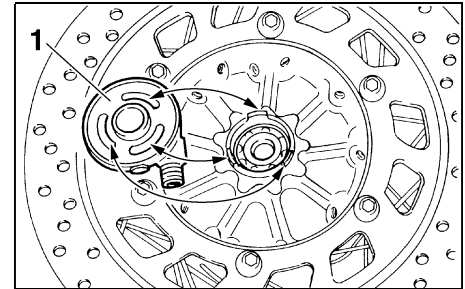

1. Speedometer gear unit

EAU04423

## Front wheel

### To remove the front wheel

EW000122

#### **WARNING**

- It is advisable to have a Yamaha dealer service the wheel.
- Securely support the motorcycle so that there is no danger of it falling over.

1. Disconnect the speedometer cable from the front wheel.

2. Loosen the front wheel axle pinch bolt, then the wheel axle.
3. Lift the front wheel off the ground according to the procedure on page 6-33.
4. Pull the wheel axle out, and then remove the wheel.

ECA00048

#### **CAUTION:**

**Do not apply the brake after the wheel has been removed together with the brake disc, otherwise the brake pads will be forced shut.**

### To install the front wheel

1. Install the speedometer gear unit into the wheel hub so that the projections mesh with the slots.
2. Lift the wheel up between the fork legs.

#### **NOTE:**

Make sure that there is enough space between the brake pads before inserting the brake disc and that the slot in the speedometer gear unit fits over the retainer on the fork leg.

3. Insert the wheel axle.
4. Lower the front wheel so that it is on the ground.

## PERIODIC MAINTENANCE AND MINOR REPAIR

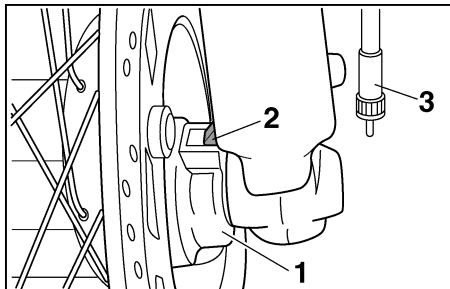

1. Speedometer gear unit
2. Retainer
3. Speedometer cable

5. Tighten the wheel axle to the specified torque.

Tightening torque:

Wheel axle:

59 Nm (5.9 m·kgf, 43 ft·lbf)

6. Tighten the front wheel axle pinch bolt to the specified torque.

Tightening torque:

Front wheel axle pinch bolt:

20 Nm (2.0 m·kgf, 14 ft·lbf)

7. Push down hard on the handlebar several times to check for proper fork operation.
8. Connect the speedometer cable.

# PERIODIC MAINTENANCE AND MINOR REPAIR

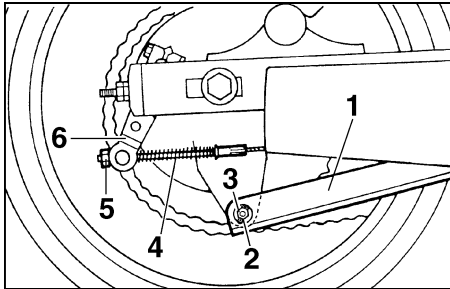

1. Brake torque rod
2. Brake torque rod cotter pin
3. Brake torque rod bolt and nut
4. Brake rod
5. Brake pedal free play adjusting nut
6. Brake cam shaft lever

EAU04850

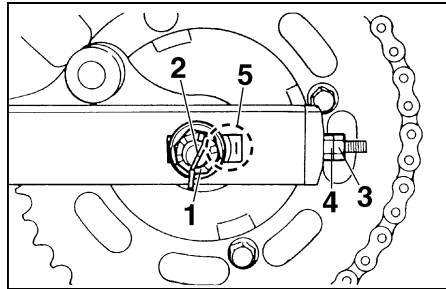

1. Axle nut
2. Axle nut cotter pin
3. Chain puller locknut
4. Drive chain slack adjusting nut
5. Alignment marks

1. Remove the axle nut cotter pin and the brake torque rod cotter pin.
2. Loosen the chain puller locknut and the drive chain slack adjusting nut on both ends of the swingarm.
3. Loosen the axle nut and the brake torque rod nut at the brake shoe plate.
4. Remove the brake pedal free play adjusting nut, and then disconnect the brake rod at the brake cam shaft lever.

5. Disconnect the brake torque rod from the brake shoe plate by removing the nut and the bolt.
6. Lift the rear wheel off the ground according to the procedure on page 6-33.
7. Remove the axle nut.
8. Pull the wheel axle out, and then remove the wheel.

6

## Rear wheel

### To remove the rear wheel

EW000122

#### **WARNING**

- It is advisable to have a Yamaha dealer service the wheel.
- Securely support the motorcycle so that there is no danger of it falling over.

# PERIODIC MAINTENANCE AND MINOR REPAIR

EAU04851

## To install the rear wheel

1. Insert the wheel axle from the right-hand side, and then install the drive chain onto the rear sprocket.
2. Install the axle nut, and then lower the rear wheel so that it is on the ground.
3. Install the brake rod onto the brake camshaft lever, and then install the brake pedal free play adjusting nut onto the brake rod.
4. Install the brake torque rod bolt at the brake shoe plate, tighten it to the specified torque, and then install the cotter pin.

Tightening torque:  
Brake torque rod bolt:  
23 Nm (2.3 m·kgf, 17 ft·lbf)

EW000110

### **WARNING**

**Always use a new cotter pin for the axle nut.**

5. Adjust the drive chain slack. (See page 6-23 for drive chain slack adjustment procedures.)
6. Tighten the axle nut to the specified torque, and then insert a new cotter pin into the axle nut.

Tightening torque:  
Axle nut:  
104 Nm (10.4 m·kgf, 75 ft·lbf)

7. Adjust the brake pedal position and free play. (See page 6-18 for brake pedal position and free play adjustment procedures.)

EW000103

### **WARNING**

**After adjusting the brake pedal free play, check the operation of the brake light.**

EAU01008

## Troubleshooting

Although Yamaha motorcycles receive a thorough inspection before shipment from the factory, trouble may occur during operation. Any problem in the fuel, compression, or ignition systems, for example, can cause poor starting and loss of power.

The following troubleshooting chart represents a quick and easy procedure for checking these vital systems yourself. However, should your motorcycle require any repair, take it to a Yamaha dealer, whose skilled technicians have the necessary tools, experience, and know-how to service the motorcycle properly.

Use only genuine Yamaha replacement parts. Imitation parts may look like Yamaha parts, but they are often inferior, have a shorter service life and can lead to expensive repair bills.

# PERIODIC MAINTENANCE AND MINOR REPAIR

## Troubleshooting chart

EAU01562

EW000125



**WARNING**

**Keep away open flames and do not smoke while checking or working on the fuel system.**

### 1. Fuel

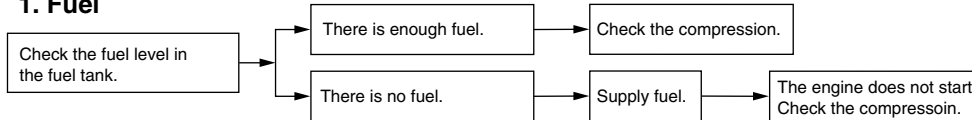

### 2. Compression

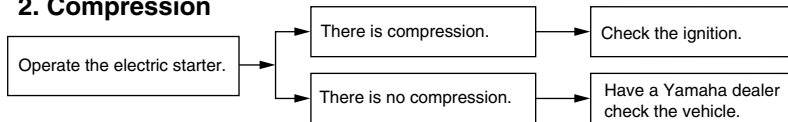

### 3. Ignition

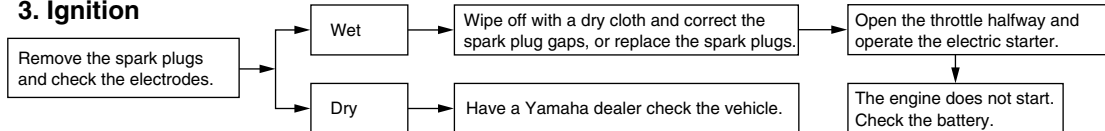

### 4. Battery

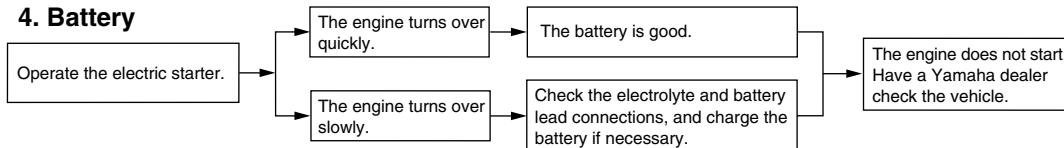

## Care

While the open design of a motorcycle reveals the attractiveness of the technology, it also makes it more vulnerable. Rust and corrosion can develop even if high-quality components are used. A rusty exhaust pipe may go unnoticed on a car, however, it detracts from the overall appearance of a motorcycle. Frequent and proper care does not only comply with the terms of the warranty, but it will also keep your motorcycle looking good, extend its life and optimize its performance.

## Before cleaning

1. Cover the muffler outlets with plastic bags after the engine has cooled down.
2. Make sure that all caps and covers as well as all electrical couplers and connectors, including the spark plug caps, are tightly installed.
3. Remove extremely stubborn dirt, like oil burnt onto the crankcase, with a degreasing agent and a brush, but never apply such products onto seals, gaskets, sprockets, the drive chain and wheel axles. Always rinse the dirt and degreaser off with water.

## Cleaning

ECA00010

### CAUTION:

- **Avoid using strong acidic wheel cleaners, especially on spoked wheels. If such products are used on hard-to-remove dirt, do not leave the cleaner on the affected area any longer than instructed. Also, thoroughly rinse the area off with water, immediately dry it, and then apply a corrosion protection spray.**
- **Improper cleaning can damage windshields, cowlings, panels and other plastic parts. Use only a soft, clean cloth or sponge with mild detergent and water to clean plastic.**

# MOTORCYCLE CARE AND STORAGE

---

---

- Do not use any harsh chemical products on plastic parts. Be sure to avoid using cloths or sponges which have been in contact with strong or abrasive cleaning products, solvent or thinner, fuel (gasoline), rust removers or inhibitors, brake fluid, antifreeze or electrolyte.
- Do not use high-pressure washers or steam-jet cleaners since they cause water seepage and deterioration in the following areas: seals (of wheel and swing-arm bearings, fork and brakes), electric components (couplers, connectors, instruments, switches and lights), breather hoses and vents.

- For motorcycles equipped with a windshield: Do not use strong cleaners or hard sponges as they will cause dulling or scratching. Some cleaning compounds for plastic may leave scratches on the windshield. Test the product on a small hidden part of the windshield to make sure that it does not leave any marks. If the windshield is scratched, use a quality plastic polishing compound after washing.

---

### After normal use

Remove dirt with warm water, a mild detergent, and a soft, clean sponge, and then rinse thoroughly with clean water. Use a toothbrush or bottlebrush for hard-to-reach areas. Stubborn dirt and insects will come off more easily if the area is covered with a wet cloth for a few minutes before cleaning.

### After riding in the rain, near the sea or on salt-sprayed roads

Since sea salt or salt sprayed on roads during winter are extremely corrosive in combination with water, carry out the following steps after each ride in the rain, near the sea or on salt-sprayed roads.

**NOTE:** \_\_\_\_\_  
Salt sprayed on roads in the winter may remain well into spring.

1. Clean the motorcycle with cold water and a mild detergent, after the engine has cooled down.

ECA00012

**CAUTION:** \_\_\_\_\_  
**Do not use warm water since it increases the corrosive action of the salt.**

2. After drying the motorcycle, apply a corrosion protection spray on all metal, including chrome- and nickel-plated, surfaces to prevent corrosion.

# MOTORCYCLE CARE AND STORAGE

## After cleaning

1. Dry the motorcycle with a chamois or an absorbing cloth.
2. Immediately dry the drive chain and lubricate it to prevent it from rusting.
3. Use a chrome polish to shine chrome, aluminum and stainless-steel parts, including the exhaust system. (Even the thermally induced discoloring of stainless-steel exhaust systems can be removed through polishing.)
4. To prevent corrosion, it is recommended to apply a corrosion protection spray on all metal, including chrome- and nickel-plated, surfaces.
5. Use spray oil as a universal cleaner to remove any remaining dirt.
6. Touch up minor paint damage caused by stones, etc.
7. Wax all painted surfaces.
8. Let the motorcycle dry completely before storing or covering it.

EWA00001

### **WARNING**

- **Make sure that there is no oil or wax on the brakes or tires. If necessary, clean the brake discs and brake linings with a regular brake disc cleaner or acetone, and wash the tires with warm water and a mild detergent.**
- **Before operating the motorcycle test its braking performance and cornering behavior.**

ECA00013

### **CAUTION:**

- **Apply spray oil and wax sparingly and make sure to wipe off any excess.**
- **Never apply oil or wax to any rubber and plastic parts, but treat them with a suitable care product.**
- **Avoid using abrasive polishing compounds as they will wear away the paint.**

### **NOTE:**

Consult a Yamaha dealer for advice on what products to use.



# MOTORCYCLE CARE AND STORAGE

---

---

## Storage

### Short-term

Always store your motorcycle in a cool, dry place and, if necessary, protect it against dust with a porous cover.

ECA00014

### CAUTION:

- **Storing the motorcycle in a poorly ventilated room or covering it with a tarp, while it is still wet, will allow water and humidity to seep in and cause rust.**
  - **To prevent corrosion, avoid damp cellars, stables (because of the presence of ammonia) and areas where strong chemicals are stored.**
- 

### Long-term

Before storing your motorcycle for several months:

1. Follow all the instructions in the “Care” section of this chapter.
2. Turn the fuel cock lever to “ON”.
3. Drain the carburetor float chambers by loosening the drain bolts; this will prevent fuel deposits from building up. Pour the drained fuel into the fuel tank.
4. Fill up the fuel tank and add fuel stabilizer (if available) to prevent the fuel tank from rusting and the fuel from deteriorating.
5. Perform the following steps to protect the cylinders, piston rings, etc. from corrosion.

- a. Remove the spark plug caps and spark plugs.
- b. Pour a teaspoonful of engine oil into each spark plug bore.
- c. Install the spark plug caps onto the spark plugs, and then place the spark plugs on the cylinder head so that the electrodes are grounded. (This will limit sparking during the next step.)
- d. Turn the engine over several times with the starter. (This will coat the cylinder walls with oil.)
- e. Remove the spark plug caps from the spark plugs, and then install the spark plugs and the spark plug caps.

EWA00003

### **WARNING**

**To prevent damage or injury from sparking, make sure to ground the spark plug electrodes while turning the engine over.**

---

# MOTORCYCLE CARE AND STORAGE

---

---

6. Lubricate all control cables and the pivoting points of all levers and pedals as well as of the sidestand/centerstand.
7. Check and, if necessary, correct the tire air pressure, and then lift the motorcycle so that both of its wheels are off the ground. Alternatively, turn the wheels a little every month in order to prevent the tires from becoming degraded in one spot.
8. Cover the muffler outlets with plastic bags to prevent moisture from entering them.
9. Remove the battery and fully charge it. Store it in a cool, dry place and charge it once a month. Do not store the battery in an excessively cold or warm place [(less than 0 °C (30 °F) or more than 30 °C (60 °F)]. For more information on storing the battery, see page 6-30.

**NOTE:** \_\_\_\_\_  
Make any necessary repairs before storing the motorcycle.  
\_\_\_\_\_

## Specifications

<b>Model</b>	<b>XV250/XV250C</b>
<b>Dimensions</b>	
Overall length	2,190 mm (86.2 in)
Overall width	815 mm (32.1 in)
Overall height	1,140 mm (44.9 in)
Seat height	685 mm (27.0 in)
Wheelbase	1,490 mm (58.7 in)
Ground clearance	145 mm (5.7 in)
Minimum turning radius	2,800 mm (110.2 in)
<b>Basic weight (with oil and full fuel tank)</b>	
XV250	147 kg (324 lb)
XV250C	148 kg (326 lb)
<b>Engine</b>	
Engine type	Air-cooled 4-stroke, SOHC
Cylinder arrangement	V-type 2-cylinder
Displacement	249 cm <sup>3</sup>
Bore × Stroke	49 × 66 mm (1.93 × 2.60 in)
Compression ratio	10:1
Starting system	Electric starter
Lubrication system	Wet sump

## Engine oil

Type

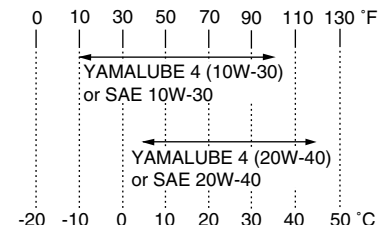

Recommended engine oil classification

API Service SE, SF, SG or higher

### CAUTION:

**In order to prevent clutch slippage (since the engine oil also lubricates the clutch), do not mix any chemical additives. Do not use oils with a diesel specification of “CD” or oils of a higher quality than specified. In addition, do not use oils labeled “ENERGY CONSERVING II” or higher.**

## Quantity

Without oil filter element replacement	1.4 L (1.2 Imp qt, 1.5 US qt)
With oil filter element replacement	1.6 L (1.4 Imp qt, 1.7 US qt)
Total amount (dry engine)	1.8 L (1.6 Imp qt, 1.9 US qt)

## Air filter

Wet element

## Fuel

Type	UNLEADED GASOLINE ONLY
Fuel tank capacity	
XV250	9.5 L (2.1 Imp gal, 2.5 US gal)
XV250C	9.2 L (2.0 Imp gal, 2.4 US gal)
Fuel reserve amount	2.6 L (0.6 Imp gal, 0.7 US gal)

## Carburetor

Manufacturer	MIKUNI
Model × quantity	BDS26 × 1

## Spark plug

Model/manufacturer	C6HSA / NGK or U20FS-U / DENSO
Gap	0.6–0.7 mm (0.02–0.03 in)

## Clutch type

Wet, multiple-disc

## Transmission

Primary reduction system	Spur gear
Primary reduction ratio	3.130
Secondary reduction system	Chain drive
Secondary reduction ratio	2.812
Number of drive chain sprocket teeth (front/rear)	16/45
Transmission type	Constant mesh 5-speed
Operation	Left foot

## Gear ratio

1st	2.643
2nd	1.684
3rd	1.261
4th	1.000
5th	0.821

## Chassis

Frame type	Double cradle
Caster angle	32°
Trail	120 mm (4.7 in)

## Tires

Front		
Type		With tube
Size		3.00-18 47P
Manufacturer/ model		CHENG SHIN / C-916
Rear		
Type		With tube
Size		130/90-15M/C 66P
Manufacturer/ model		CHENG SHIN / C-915

# SPECIFICATIONS

## Maximum load\*

XV250	196 kg (432 lb)
XV250C	195 kg (430 lb)

## Tire air pressure (measured on cold tires)

### Up to 90 kg (198 lb)\*

Front	175 kPa (1.75 kgf/cm <sup>2</sup> , 25 psi)
Rear	200 kPa (2.00 kgf/cm <sup>2</sup> , 29 psi)

### 90 kg (198 lb)—maximum\*

Front	200 kPa (2.00 kgf/cm <sup>2</sup> , 29 psi)
Rear	225 kPa (2.25 kgf/cm <sup>2</sup> , 33 psi)

\* Total weight of rider, passenger, cargo and accessories

## Wheels

### Front

Type	Spoke wheel
Size	18 × 1.60

### Rear

Type	Spoke wheel
Size	15M/C × MT 2.75

## Brakes

### Front

Type	Single disc brake
Operation	Right hand
Fluid	DOT 4

### Rear

Type	Drum brake
Operation	Right foot

## Suspension

Front	Telescopic fork
Rear	Swingarm

## Spring/shock absorbers

Front	Coil spring / oil damper
Rear	Coil spring / oil damper

## Wheel travel

Front	140 mm (5.5 in)
Rear	100 mm (3.9 in)

## Electrical system

Ignition system	T.C.I. (digital)
Charging system	
Type	A.C. magneto
Standard output	14 V, 25 A @ 5,000 r/min

### Battery

Model	GM10-3A-2
Voltage, capacity	12 V, 10 Ah

## Headlight type

Quartz bulb (halogen)

**Bulb voltage, wattage × quantity**

Headlight	12 V, 60/55 W × 1
Tail/brake light	12 V, 8/27 W × 1
Front turn signal / position light	12 V, 27/8 W × 2
Rear turn signal light	12 V, 27 W × 2
Meter lighting	14 V, 3 W × 1
Neutral indicator light	14 V, 3 W × 1
High beam indicator light	12 V, 1.7 W × 1
Turn signal indicator light	14 V, 3 W × 1

**Fuses**

Main fuse	20 A
Signaling system fuse	10 A

## Identification numbers

EAU02944

Record the key identification number, vehicle identification number and model label information in the spaces provided below for assistance when ordering spare parts from a Yamaha dealer or for reference in case the vehicle is stolen.

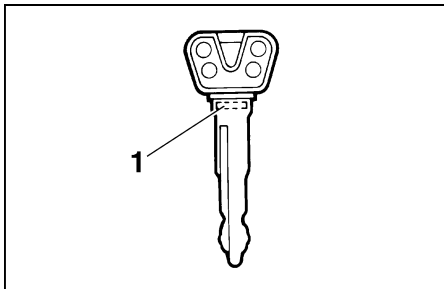

1. Key identification number

1. KEY IDENTIFICATION NUMBER:

2. VEHICLE IDENTIFICATION NUMBER:

3. MODEL LABEL INFORMATION:

EAU01042

### Key identification number

The key identification number is stamped into the key. Record this number in the space provided and use it for reference when ordering a new key.

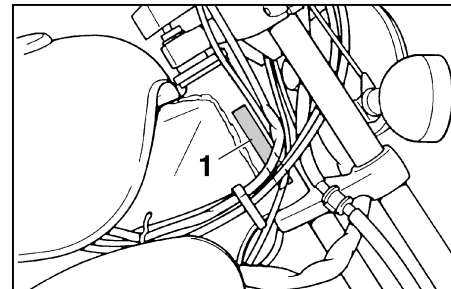

1. Vehicle identification number

EAU01043

### Vehicle identification number

The vehicle identification number is stamped into the steering head pipe. Record this number in the space provided.

**NOTE:** \_\_\_\_\_

The vehicle identification number is used to identify your motorcycle and may be used to register your motorcycle with the licensing authority in your area.

\_\_\_\_\_

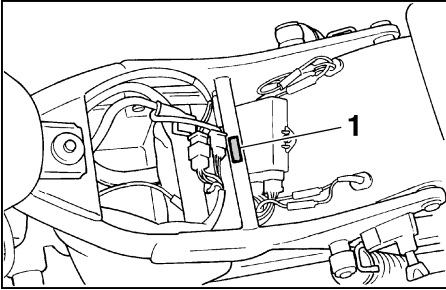

1. Model label

EAU01804

## Model label

The model label is affixed to the frame under the rider seat. (See page 3-8 for rider seat removal and installation procedures.) Record the information on this label in the space provided. This information will be needed when ordering spare parts from a Yamaha dealer.



# CONSUMER INFORMATION

---

---

EAU01051

## REPORTING SAFETY DEFECTS

If you believe that your vehicle has a defect which could cause a crash or could cause injury or death, you should immediately inform the National Highway Traffic Safety Administration (NHTSA) in addition to notifying Yamaha Motor Corporation, U.S.A. If NHTSA receives similar complaints, it may open an investigation, and if it finds that a safety defect exists in group of vehicles, it may order a recall and remedy campaign. However, NHTSA cannot become involved in individual problems between you, your dealer, or Yamaha Motor Corporation, U.S.A.

To contact NHTSA, you may either call the Auto Safety Hotline toll-free at 1-800-424-9393 (or 366-0123 in Washington, D.C. area) or write to: NHTSA, U.S. Department of Transportation, Washington, D.C. 20590. You can also obtain other information about motor vehicle safety from the Hotline.

## MOTORCYCLE NOISE REGULATION

### TAMPERING WITH NOISE CONTROL SYSTEM PROHIBITED:

Federal law prohibits the following acts or the causing thereof: (1) The removal or rendering inoperative by any person other than for purposes of maintenance, repair, or replacement of any device or element of design incorporated into any new vehicle for the purpose of noise control prior to its sale or delivery to the ultimate purchaser or while it is in use or (2) the use of the vehicle after such device or element of design has been removed or rendered inoperative by any person.

“AMONG THOSE ACTS PRESUMED TO CONSTITUTE TAMPERING ARE THE ACTS LISTED BELOW”.

These acts include tampering with the following systems; i.e., modification, removal, etc.

Exhaust system	Muffler Exhaust pipe Silencer
Intake system	Air cleaner case Air cleaner element Intake duct

# CONSUMER INFORMATION

EAU03052

## Maintenance record

Copies of work orders and/or receipts for parts purchased and installed on your motorcycle will be required to document that maintenance has been completed in accordance with the emissions warranty. The chart below is printed only as a reminder that maintenance work is required. It is not acceptable proof of maintenance work.

Maintenance interval	Date of service	Mileage	Servicing dealer name and address	Remarks
600 mi (1,000 km) or 1 month				
4,000 mi (6,000 km) or 6 months				
7,000 mi (11,000 km) or 12 months				
10,000 mi (16,000 km) or 18 months				
13,000 mi (21,000 km) or 24 months				
16,000 mi (26,000 km) or 30 months				
19,000 mi (31,000 km) or 36 months				

# CONSUMER INFORMATION

<b>Maintenance interval</b>	<b>Date of service</b>	<b>Mileage</b>	<b>Servicing dealer name and address</b>	<b>Remarks</b>
22,000 mi (36,000 km) or 42 months				
25,000 mi (41,000 km) or 48 months				
28,000 mi (46,000 km) or 54 months				
31,000 mi (51,000 km) or 60 months				

# CONSUMER INFORMATION

EAU02918

## YAMAHA MOTOR CORPORATION, U.S.A. STREET AND ENDURO MOTORCYCLE LIMITED WARRANTY

Yamaha Motor Corporation, U.S.A. hereby warrants each new model Yamaha motorcycle will be free from defects in material and workmanship for the period of time stated herein, subject to certain stated limitations.

**THE PERIOD OF WARRANTY** for Yamaha motorcycles originally equipped with headlight, stoplight, and turn signals shall be one (1) year from the date of purchase, with no mileage limitation.

**MODELS EXCLUDED FROM WARRANTY** include those used for non-Yamaha-authorized renting, leasing, or other commercial purposes, and TZ models.

**DURING THE PERIOD OF WARRANTY** any authorized Yamaha motorcycle dealer will, free of charge, repair or replace any part adjudged defective by Yamaha due to faulty workmanship or material from the factory. Parts used in warranty repairs will be warranted for the balance of the product's warranty period. All parts replaced under warranty become property of Yamaha Motor Corp. U.S.A.

**GENERAL EXCLUSIONS** from this warranty shall include any failures caused by:

- a. Competition or racing use.
- b. Installation of parts or accessories that are not qualitatively equivalent to genuine Yamaha parts.
- c. Abnormal strain, neglect, or abuse.
- d. Lack of proper maintenance.
- e. Accident or collision damage.
- f. Modification to original parts.

**SPECIFIC EXCLUSIONS** from this warranty shall include parts replaced due to normal wear or routine maintenance.

**THE CUSTOMER'S RESPONSIBILITY** under this warranty shall be to:

1. Operate and maintain the motorcycle as specified in the appropriate Owner's Manual, and
2. Give notice to an authorized Yamaha motorcycle dealer of any and all apparent defects within ten (10) days after discovery, and make the machine available at that time for inspection and repairs at such dealer's place of business.

**WARRANTY TRANSFER:** To transfer the warranty from the original purchaser to any subsequent purchaser, it is imperative that the machine be inspected and registered for warranty by an authorized Yamaha motorcycle dealer. In order for this warranty to remain in effect, this inspection and registration must take place within ten (10) days after transfer. An inspection and registration fee will be charged for this service.

### EMISSIONS CONTROL SYSTEM WARRANTY

Yamaha Motor Corporation, U.S.A. also warrants to the ultimate purchaser and each subsequent purchaser of each Yamaha motorcycle covered by this warranty with a displacement of 50cc or greater, that the vehicle is designed, built, and equipped so as to conform at the time of sale with all U.S. emissions standards applicable at the time of manufacture and that it is free from defects in materials and workmanship which would cause it not to meet these standards within the periods listed immediately below. Failure other than those resulting from defects in material or workmanship which arise solely as a result of owner abuse and / or lack of proper maintenance are not covered by this warranty.

ENGINE DISPLACEMENT	PERIOD
50cc to 169cc	12,000 km (7,465 miles) or five years, whichever occurs first
170cc to 279cc	18,000 km (11,185 miles) or five years, whichever occurs first
280cc or over	30,000 km (18,641 miles) or five years, whichever occurs first

**YAMAHA MOTOR CORPORATION, U.S.A. MAKES NO OTHER WARRANTY OF ANY KIND, EXPRESSED OR IMPLIED. ALL IMPLIED WARRANTIES OF MERCHANTABILITY AND FITNESS FOR A PARTICULAR PURPOSE WHICH EXCEED THE OBLIGATIONS AND TIME LIMITS STATED IN THIS WARRANTY ARE HEREBY DISCLAIMED BY YAMAHA MOTOR CORPORATION, U.S.A. AND EXCLUDED FROM THIS WARRANTY.**

**SOME STATES DO NOT ALLOW LIMITATIONS ON HOW LONG AN IMPLIED WARRANTY LASTS, SO THE ABOVE LIMITATION MAY NOT APPLY TO YOU. ALSO EXCLUDED FROM THIS WARRANTY ARE ANY INCIDENTAL OR CONSEQUENTIAL DAMAGES INCLUDING LOSS OF USE. SOME STATES DO NOT ALLOW THE EXCLUSION OR LIMITATION OF INCIDENTAL OR CONSEQUENTIAL DAMAGES, SO THE ABOVE EXCLUSION MAY NOT APPLY TO YOU.**

**THIS WARRANTY GIVES YOU SPECIFIC LEGAL RIGHTS, AND YOU MAY ALSO HAVE OTHER RIGHTS WHICH VARY FROM STATE TO STATE.**

YAMAHA MOTOR CORPORATION, U.S.A.  
P.O. Box 6555  
Cypress, California 90630

## WARRANTY QUESTIONS AND ANSWERS

- Q. What costs are my responsibility during the warranty period?
- A. The customer's responsibility includes all costs of normal maintenance services, non-warranty repairs, accident and collision damages, and oil, oil filters, air filters, spark plugs, and brake shoes.
- Q. What are some examples of "abnormal" strain, neglect, or abuse?
- A. These terms are general and overlap each other in areas. Specific examples include: Running the machine out of oil, sustained high-rpm, full-throttle, operating the machine with a broken or damaged part which causes another part to fail, damage or failure due to improper or careless transportation and or tie down. If you have any specific questions on operation or maintenance, please contact your dealer for advice.
- Q. Does the warranty cover incidental costs such as towing or transportation due to a failure?
- A. No. The warranty is limited to repair of the machine itself.
- Q. May I perform any or all of the recommended maintenance shown in the Owner's Manual instead of having the dealer do them?
- A. Yes, if you are a qualified mechanic and follow the procedures specified in the Owner's and Service Manual. We do recommend, however, that items requiring special tools or equipment be done by Yamaha Motorcycle dealer.
- Q. Will the warranty be void or cancelled if I do not operate or maintain my new motorcycle exactly as specified in the Owner's Manual?
- A. No. The warranty on a new motorcycle cannot be "voided" or "cancelled." **However, if a particular failure is caused by operation or maintenance other than as shown in the Owner's Manual, that failure may not be covered under warranty.**
- Q. What responsibility does my dealer have under this warranty?
- A. Each Yamaha Motorcycle dealer is expected to:
1. Completely set up every new machine before sale.
  2. Explain the operation, maintenance, and warranty requirements to your satisfaction at the time of sale, and upon your request at any later date.
  3. Each Yamaha Motorcycle dealer is held responsible for his setup, service and warranty repair work.
- Q. Is the warranty transferable to second owners?
- A. Yes. The remainder of the existing warranty can be transferred upon request. The unit has to be inspected and re-registered by an authorized Yamaha Motorcycle dealer for the policy to remain effective.

## CUSTOMER SERVICE

If your machine requires warranty service, you must take it to any authorized Yamaha Motorcycle dealer within the continental United States. Be sure to bring your warranty registration card or other valid proof of the original date of purchase. If a question or problem arises regarding warranty, first contact the owner of the dealership. Since all warranty matters are handled at the dealer level, this person is in the best position to help you. If you are still not satisfied and require additional assistance, please write:

YAMAHA MOTOR CORPORATION U.S.A.  
CUSTOMER RELATIONS DEPARTMENT  
P.O. Box 6555  
Cypress, California 90630

When contacting Yamaha Motor Corporation, U.S.A. don't forget to include any important information such as names, addresses, model, V.I.N. (frame number), dates, and receipts.

## CHANGE OF ADDRESS

The federal government requires each manufacturer of a motor vehicle to maintain a complete, up-to-date list of all first purchasers against the possibility of a safety-related defect and recall. This list is compiled from the purchase registrations sent to Yamaha Motor Corporation, U.S.A. by the selling dealer at the time of your purchase.

If you should move after you have purchased your new motorcycle, please advise us of your new address by sending a postcard listing your motorcycle model name, V.I.N. (frame number), dealer number (or dealer's name) as it is shown on your warranty card, your name and new mailing address. Mail to:

YAMAHA MOTOR CORPORATION, U.S.A.  
P.O. Box 6555  
Cypress, California 90630  
Attention: Warranty Department

This will ensure that Yamaha Motor Corporation, U.S.A. has an up-to-date registration record in accordance with federal law.

## YAMAHA EXTENDED SERVICE (Y.E.S.)

Keep your Yamaha protected even after your warranty expires with genuine Yamaha Extended Service (Y.E.S.).

- Y.E.S. is designed and administered by Yamaha Motor Corporation to provide maximum owner satisfaction. You get uninterrupted factory-backed coverage for extra peace of mind.
- Y.E.S. is flexible. You choose the plan that's right for you: 12 months, 24 months, or 36 months beyond your warranty period.
- Y.E.S. is designed and administered by the same Yamaha people who handle your warranty – and it shows in the comprehensive coverage benefits. There are no mileage limitations. Coverage isn't limited to "moving parts" or the "drive train" like many other plans. And Y.E.S. covers manufacturing defects just like the warranty. See the sample contract at your Yamaha dealer to see how comforting uninterrupted factory-backed protection can be.
- You don't have to pay anything for covered repairs. There's no deductible to pay, and repairs aren't "pro-rated." You don't have any "out-of-pocket" expenses for covered repairs.

- In addition, Travel and Recreation Interruption Protection (TRIP) is included at no extra cost. TRIP gives you up to \$150 reimbursement per occurrence for any reasonable expenses you incur because your Yamaha needs covered service: replacement vehicle rental, emergency towing, phone calls, even food and lodging when you are away from home. This superb coverage goes into effect when you purchase Y.E.S., so it applies to any warranty repairs as well as covered repairs during your entire Y.E.S. plan period.
- Y.E.S. coverage is honored at any authorized Yamaha dealer nationwide.
- Y.E.S. coverage is transferable to a new owner if you sell or trade-in. That can make your Yamaha much more valuable!

This excellent Y.E.S. plan coverage is only available to Yamaha owners like you, and only while your Yamaha is still within the Yamaha Limited Warranty period. So visit your authorized Yamaha dealer to get all the facts. He can show you how easy it is to protect your investment with Yamaha Extended Service.

We urge you to act now. You'll get the excellent benefits of TRIP coverage right away, and you'll rest easy knowing you'll have strong factory-backed protection even after your Yamaha Limited Warranty expires. You can also save money: Y.E.S. costs less within the first 90 days after you buy your Yamaha. See your dealer today!

A special note:

If visiting your dealer isn't convenient, contact Yamaha with your Primary ID number (your frame number). We'll be happy to help you get the Y.E.S. coverage you need.

Yamaha Service Marketing  
P.O. Box 6555  
Cypress, CA 90630



**YAMAHA EXTENDED SERVICE**



***PROTECT YOUR INVESTMENT***

***Use Genuine YAMAHA Parts And Accessories***

***See your Authorized YAMAHA Dealer for a Genuine YAMAHA Service Manual.***



YAMAHA MOTOR CO., LTD.

PRINTED ON RECYCLED PAPER

PRINTED IN JAPAN  
2002.05-0.5x1 CR  
(E)