

EBU00941

INTRODUCTION

Congratulations on your purchase of the Yamaha YFM350FA. It represents the result of many years of Yamaha experience in the production of fine sporting, touring, and pace-setting racing machines. With the purchase of this Yamaha, you can now appreciate the high degree of craftsmanship and reliability that have made Yamaha a leader in these fields.

This manual will provide you with a good basic understanding of the features and operation of this ATV. **This manual includes important safety information. It provides information about special techniques and skills necessary to ride your ATV.** It also includes basic maintenance and inspection procedures. If you have any questions regarding the operation or maintenance of your ATV, please consult a Yamaha dealer.

AN IMPORTANT SAFETY MESSAGE:

- READ THIS MANUAL TOGETHER WITH TIPS FOR THE ATV RIDER CAREFULLY AND COMPLETELY BEFORE OPERATING YOUR ATV. MAKE SURE YOU UNDERSTAND ALL INSTRUCTIONS.
- PAY CLOSE ATTENTION TO THE WARNING AND CAUTION LABELS ON THE ATV.
- NEVER OPERATE AN ATV WITHOUT PROPER TRAINING OR INSTRUCTION. FREE TRAINING IS AVAILABLE TO ANYONE WHO BUYS A NEW ATV. CALL 1-800-887-2887

N.

EBU00801

IMPORTANT MANUAL INFORMATION

FAILURE TO FOLLOW THE WARNINGS CONTAINED IN THIS MANUAL CAN RESULT IN SERIOUS INJURY OR DEATH.

Particularly important information is distinguished in this manual by the following notations:



The Safety Alert Symbol means **ATTENTION! BECOME ALERT! YOUR SAFETY IS INVOLVED!**



Failure to follow **WARNING** instructions could result in severe injury or death to the machine operator, a bystander or a person inspecting or repairing the machine.

CAUTION:

A **CAUTION** indicates special precautions that must be taken to avoid damage to the machine.

NOTE:

A **NOTE** provides key information to make procedures easier or clearer.

EBU00011

IMPORTANT NOTICE

This machine is designed and manufactured for OFF-ROAD use only. It is illegal and unsafe to operate this machine on any public street, road or highway.

This machine complies with all applicable OFF-ROAD noise level and spark arrester laws and regulations in effect at the time of manufacture.

Please check your local riding laws and regulations before operating this machine.

EBU01067



YFM350FAS
OWNER'S MANUAL
©2003 by Yamaha Motor Corporation,
U.S.A.
1st edition, July 2003
All rights reserved. Any reprinting or
unauthorized use without the written
permission of
Yamaha Motor Corporation

EBU00014

⚠ WARNING

Indicates a potential hazard that could result in serious injury or death.

CONTENTS

1	LOCATION OF THE WARNING AND SPECIFICATION LABELS.....	1-1
2	SAFETY INFORMATION.....	2-1
3	DESCRIPTION AND MACHINE IDENTIFICATION	3-1
	Identification number records.....	3-2
	Key identification number.....	3-2
	ber	3-3
4	CONTROL FUNCTIONS.....	4-1
	Main switch	4-1
	Indicator and warning lights	4-2
	Handlebar switches	4-5
	Throttle lever	4-8
	Speed limiter	4-9
	Front brake lever.....	4-10
	Brake pedal and rear brake lever	4-10
	Parking brake.....	4-11
	Drive select lever	4-12
	Recoil starter.....	4-12
	Fuel tank cap	4-13
	Fuel cock.....	4-14
	Starter (choke)	4-15
	Seat.....	4-16
	Storage box.....	4-17
	Front carrier	4-18
	Rear carrier	4-18

5	PRE-OPERATION CHECKS	5-1
	Front and rear brakes	5-2
	Fuel	5-4
	Engine oil	5-6
	Final gear oil.....	5-6
	Differential gear oil	5-7
	Throttle lever	5-7
	Fittings and fasteners.....	5-7
	Lights.....	5-7
	Switches.....	5-7
	Tires	5-8
	How to measure tire pressure.....	5-10
	Tire wear limit.....	5-11

6	OPERATION	6-1
	Starting a cold engine	6-1
	Starting a warm engine.....	6-3
	Warming up.....	6-3

	Accessories and loading	6-10
7	RIDING YOUR ATV	7-1
	Getting to know your ATV	7-3
	Ride with care and good judgement.....	7-4
	Be careful where you ride.....	7-16
	Turning your ATV	7-22
	Climbing uphill	7-24
	Riding downhill	7-30
	Crossing a slope.....	7-32
	Crossing through shallow water	7-34
	Riding over rough terrain.....	7-37
	Sliding and skidding.....	7-38
	What to do if.....	7-40
	What to do	7-40

8	PERIODIC MAINTENANCE AND ADJUSTMENT	8-1
	Owner's manual and tool kit.....	8-1
	Periodic maintenance/ lubrication	8-3
	Panel removal and installation	8-5
	Engine oil and oil filter cartridge	8-6
	Final gear oil.....	8-11
	Differential gear oil replacement ...	8-14
	Axle boots.....	8-16
	Spark plug inspection.....	8-16
	Air filter element cleaning.....	8-19
	V-belt cooling duct check hose	8-22
	V-belt case drain plug.....	8-22
	Spark arrester cleaning	8-23
	Carburetor adjustment.....	8-24
	Idle speed adjustment	8-25
	Valve clearance adjustment.....	8-25
	Front brake lever free play.....	8-30
	Rear brake pedal and lever adjustment	8-31
	Adjusting the rear brake light switch	8-34
	Cable inspection and lubrication....	8-35
	Lubricating the brake levers and brake pedal	8-35
	Wheel removal.....	8-36
	Wheel installation.....	8-37
	Battery.....	8-38
	Battery maintenance.....	8-39
	Fuse replacement	8-39
	Replacing a headlight bulb	8-41
	Headlight beam adjustment.....	8-44
	Tail/brake light bulb replacement	8-45
	Troubleshooting	8-45
	Troubleshooting chart	8-47

10	SPECIFICATIONS.....	10-1
11	NOISE REGULATION.....	11-1
12	MAINTENANCE RECORD	12-1
13	ATV LIMITED WARRANTY.....	13-1
14	YAMAHA EXTENDED SERVICE (Y.E.S.)	14-1

EBU00464

LOCATION OF THE WARNING AND SPECIFICATION LABELS

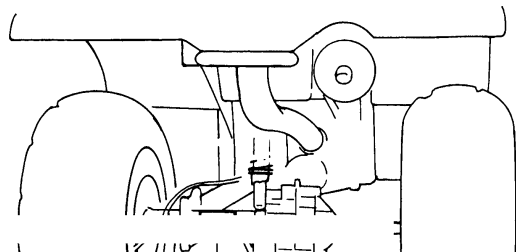
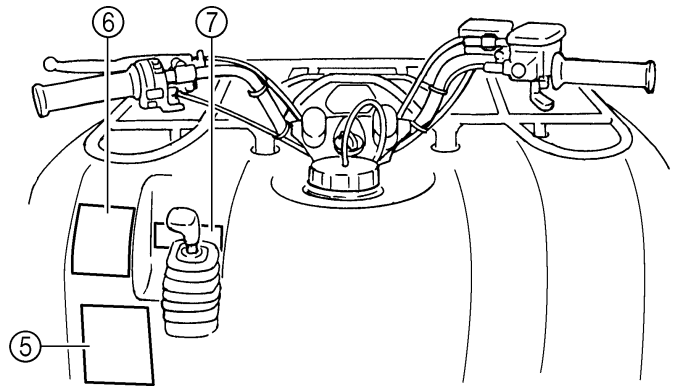
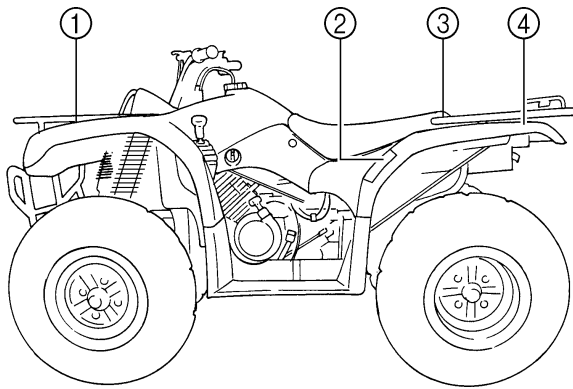

Read and understand all of the labels on your machine. They contain important information for safe and proper operation of your ATV.

Never remove any labels from your ATV. If a label becomes difficult to read or comes off, a replacement label is available from your Yamaha dealer.

①

⚠ WARNING

Overloading this ATV or carrying cargo improperly can change handling, stability and braking performance and can lead to an accident. Never exceed the maximum front cargo limit of
: **40kg (88 lbs)**
NEVER sit on the carrier. Refer to instructions in the Owner's Manual.

5ND-F4877-00

②

⚠ WARNING

IMPROPER TIRE PRESSURE OR OVERLOADING CAN CAUSE LOSS OF CONTROL. LOSS OF CONTROL CAN RESULT IN SEVERE INJURY OR DEATH.

OPERATING TIRE PRESSURE: Set with tires cold

- Recommended: FRONT : 25kPa, {0.25kgf/cm²}, 3.6psi
REAR : 25kPa, {0.25kgf/cm²}, 3.6psi
- Minimum : FRONT : 22kPa, {0.22kgf/cm²}, 3.2psi
REAR : 22kPa, {0.22kgf/cm²}, 3.2psi
- Never set tire pressure below minimum. It could cause the tire to dislodge from the rim.

LOADING/TRAILER TOWING

- Cargo or a trailer can affect stability and handling.

③

⚠ WARNING

NEVER ride as a passenger.

Passengers can cause a loss of control, resulting in **SEVERE INJURY** or **DEATH**.



YAMAHA

④

⚠ WARNING

Overloading this ATV or carrying cargo improperly can change handling, stability and braking performance and can lead to an accident. Never exceed the maximum rear cargo limit of : **80kg (176 lbs)**

NEVER sit on the carrier. Refer to instructions in the Owner's Manual.

5ND-F4897-00

⑤

⚠ WARNING

Improper ATV use can result in **SEVERE INJURY** or **DEATH**.



ALWAYS USE AN APPROVED HELMET AND PROTECTIVE GEAR **NEVER USE ON PUBLIC ROADS** **NEVER CARRY PASSENGERS** **NEVER USE WITH DRUGS OR ALCOHOL**

NEVER operate :

- without proper training or instruction.
- at speeds too fast for your skills or the conditions.
- on public roads - a collision can occur with another vehicle.
- with a passenger - passengers affect balance and steering and increase risk of losing control.

ALWAYS :

- use proper riding techniques to avoid vehicle overturns on hills and rough terrain and in turns.
- avoid paved surfaces - pavement may seriously affect handling and control.

⑥

⚠ WARNING



Operating this ATV if you are under the age of 16 increases your chance of severe injury or death.

NEVER operate this ATV if you are under age 16.

YAMAHA 4XE-F415A-00

⑦

DRIVE SELECT LEVER

- Read owner's manual carefully before operating.
- ATV **MUST** be stopped before shifting select lever.
- Shifting into reverse is impossible without applying foot brake.

5TE-F151E-00

⑧

MAXIMUM LOADING LIMIT

PULLING LOAD:	4900 N (500 kgf)
	1102 lbf
TONGUE WEIGHT:	147 N (15 kgf)
	33 lbf

5ND-F151K-00

EBU13401



SAFETY INFORMATION

AN ATV IS NOT A TOY AND CAN BE HAZARDOUS TO OPERATE. An ATV handles differently from other vehicles including motorcycles and cars. A collision or rollover can occur quickly, even during routine maneuvers such as turning and riding on hills or over obstacles, if you fail to take proper precautions.

SEVERE INJURY OR DEATH can result if you do not follow these instructions:

- Read this manual and all labels carefully and follow the operating procedures described.
- Never operate an ATV without proper training or instruction. **Take a Training Course.** Beginners should receive training from a certified instructor. Contact an authorized ATV dealer or call 1-800-887-2887 to find out about the training courses nearest you.
- Always follow the age recommendation:
 - A child under 16 years old should never operate an ATV with engine size greater than 90cc.
- Never allow a child under age 16 to operate an ATV without adult supervision, and never allow continued use of an ATV by a child if he or she does not have the abilities to operate it safely.
- Never carry a passenger on an ATV.

TV on any paved surfaces, including sidewalks, driveways, park-

ing lots and streets



- Never operate an ATV without wearing an approved motorcycle helmet that fits properly. You should also wear eye protection (goggles or face shield), gloves, boots, a long-sleeved shirt or a jacket, and long pants.
- Never consume alcohol or drugs before or while operating this ATV.
- Never operate at speeds too fast for your skills or the conditions. Always go at a speed that is proper for the terrain, visibility, operating conditions, and your experience.
- Never attempt wheelies, jumps, or other stunts.
- Always inspect your ATV each time you use it to make sure it is in safe operating condition. Always follow the inspection and maintenance procedures and schedules described in this manual.
- Always keep both hands on the handlebars and both feet on the footboards of the ATV during operation.
- Always go slowly and be extra careful when operating on unfamiliar terrain. Always be alert to changing terrain conditions when operating the ATV.
- Never operate on excessively rough, slippery or loose terrain until you have learned and practiced the skills necessary to control the ATV on such terrain. Always be especially cautious on these kinds of terrain.

Always follow proper procedures for turning as described in this manual. Practice turning at low speeds. Do not turn at excessive speeds.

- Always follow proper procedures for climbing hills as described in this manual. Check the terrain carefully before you start up any hill. Never climb hills with excessively slippery or loose surfaces. Shift your weight forward. Never open the throttle suddenly. Never go over the top of a hill at high speed.
- Always follow proper procedures for going down hills and for braking on hills as described in this manual. Check the terrain carefully before you start down any hill. Shift your weight backward. Never go down a hill at high speed. Avoid going down a hill at an angle that would cause the vehicle to lean sharply to one side. Go straight down the hill where possible.
- Always follow proper procedures for crossing the side of a hill as described in this manual. Avoid hills with excessively slippery or loose surfaces. Shift your weight to the uphill side of the ATV. Never attempt to turn the ATV around on any hill until you have mastered the turning technique described in this manual on level ground. Avoid crossing the side of a steep hill if possible.
- Always use proper procedures if you stall or roll backwards when climbing a hill. Maintain a steady speed when climbing a hill. If you stall or roll backwards, follow the special procedure for braking described in this manual. Dismount on the uphill side or to a side if pointed straight uphill. Turn the ATV around and remount, following the procedure described in this manual. Always check for obstacles before operating in a new area. Never attempt to operate over a rock or fallen trees. Always follow proper procedures when on

- Always be careful when skidding or sliding. Learn to safely control skidding or sliding by practicing at low speeds and on level, smooth terrain. On extremely slippery surfaces, such as ice, go slowly and be very cautious in order to reduce the chance of skidding or sliding out of control.
- Never operate an ATV in fast flowing water or in water deeper than that recommended in this manual. Remember that wet brakes may have reduced stopping ability. Test your brakes after leaving water. If necessary, apply them several times to let friction dry out the linings.
- Always be sure there are no obstacles or people behind you when you operate in reverse. When it is safe to proceed in reverse, go slowly.
- Always use the size and type of tires specified in this manual.
- Always maintain proper tire pressure as described in this manual.
- Never modify an ATV through improper installation or use of accessories.
- Never exceed the stated load capacity for an ATV. Cargo should be properly distributed and securely attached. Reduce speed and follow instructions in this manual for carrying cargo or pulling a trailer. Allow greater distance for braking.

FOR MORE INFORMATION ABOUT ATV SAFETY, call the Consumer Products Safety Commission at 1-800-638-2772, or the ATV Distributor's Safety Hotline at 1-800-852-5344.

 **WARNING**

POTENTIAL HAZARD

Improper handling of gasoline.

WHAT CAN HAPPEN

Gasoline can catch fire and you could be burned.

HOW TO AVOID THE HAZARD

Always turn off the engine when refueling.

Do not refuel immediately after the engine has been running and is still very hot.

Do not spill gasoline on the engine or exhaust pipe/muffler when refueling.

Never refuel while smoking, or in the vicinity of sparks, open flames, or other sources of ignition such as the pilot clothes dry-

When transporting the ATV in another vehicle, be sure it is kept upright and that the fuel cock is in the “OFF” position. Otherwise, fuel may leak out of the carburetor or fuel tank.

WHAT CAN HAPPEN

Gasoline is poisonous and can cause injuries.

HOW TO AVOID THE HAZARD

If you should swallow some gasoline or inhale a lot of gasoline vapor, or get some gasoline in your eyes, see your doctor immediately.

If gasoline spills on your skin, wash with soap and water. If gasoline spills on your clothing, change your clothes.

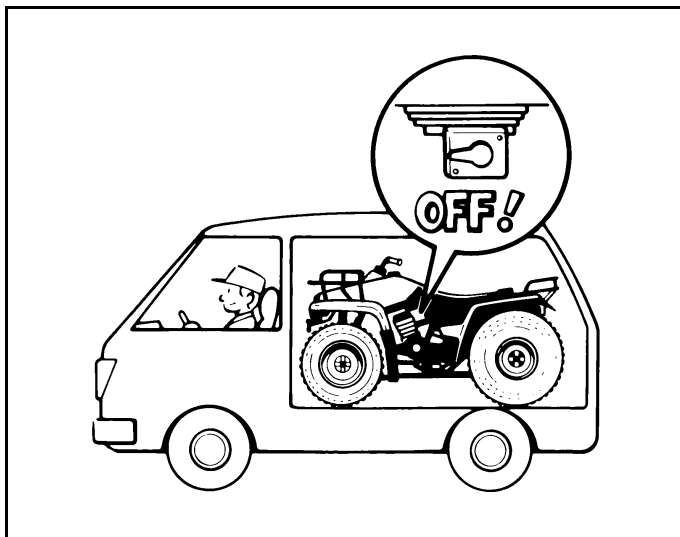

⚠ WARNING

POTENTIAL HAZARD

Starting or running the engine in a closed area.

WHAT CAN HAPPEN

Exhaust fumes are poisonous and may cause loss of consciousness and death within a short time.

HOW TO AVOID THE HAZARD

Always operate your ATV in an area with adequate ventilation.

EBU00032

DESCRIPTION AND MACHINE IDENTIFICATION

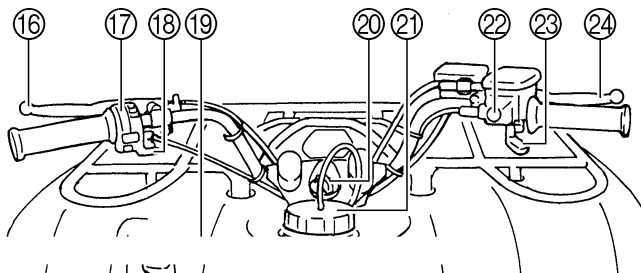
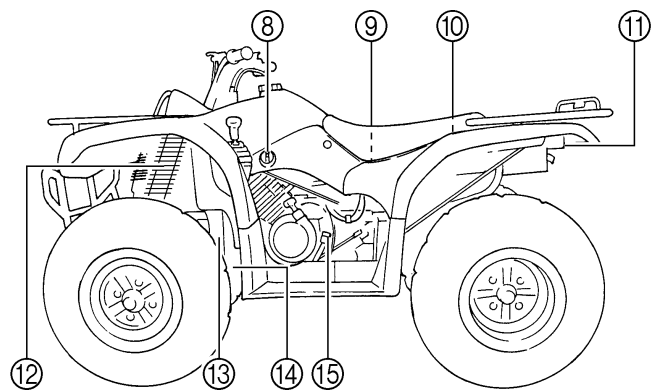
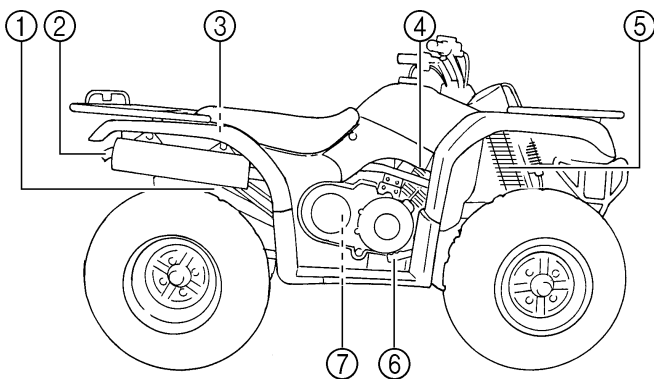

- | | |
|---|------------------------------------|
| 1. Rear shock absorber assembly
spring preload adjusting ring | 13. V-belt cooling duct check hose |
| 2. Spark arrester | 14. Oil filter cartridge |
| 3. Storage box and tool kit | 15. Engine oil dipstick |
| 4. Spark plug | 16. Rear brake lever |
| 5. Front shock absorber assembly
spring preload adjusting ring | 17. Left handlebar switches |
| 6. Brake pedal | 18. Starter (choke) |
| 7. V-belt case | 19. Drive select lever |
| 8. Fuel cock | 20. Main switch |
| 9. Air filter case | 21. Fuel tank cap |
| 10. Fuses | 22. Right handlebar switch |
| 11. Tail/brake light | 23. Throttle lever |
| 12. Front shock absorber assembly | 24. Front brake lever |

EBU00600

Identification number records

Record the key identification number, vehicle identification number and model label information in the spaces provided for assistance when ordering spare parts from a Yamaha dealer or for reference in case the vehicle is stolen.

1. KEY IDENTIFICATION NUMBER:

2. VEHICLE IDENTIFICATION NUMBER:

3. MODEL LABEL INFORMATION:

EBU00035

Key identification number

The key identification number is stamped on the key as shown in the following illustration. This number can be used for ordering a new key.

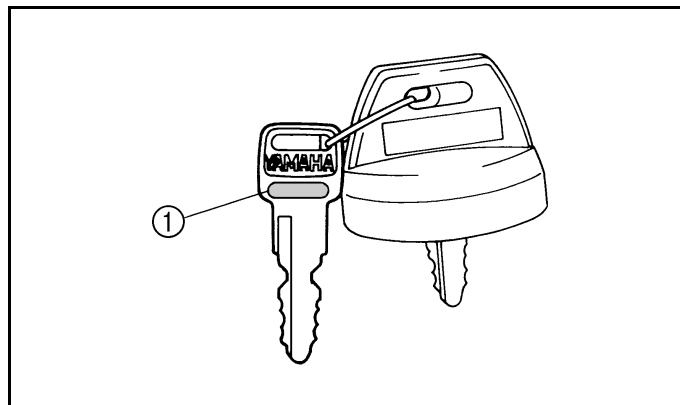

1. Key identification number

EBU00036

Vehicle identification number

The vehicle identification number is stamped into the frame.

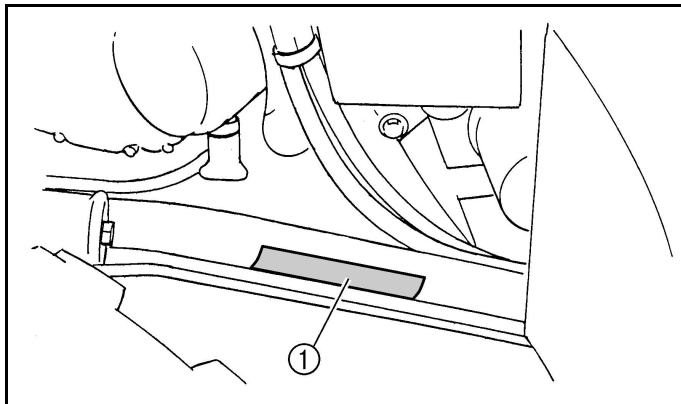

1. Vehicle identification number (front left side)

NOTE:

The vehicle identification number is used to identify your machine.

EBU00787

Model label

The model label is affixed to the location in the illustration. Record the information on this label in the space provided. This information will be needed to order spare parts from your Yamaha dealer.

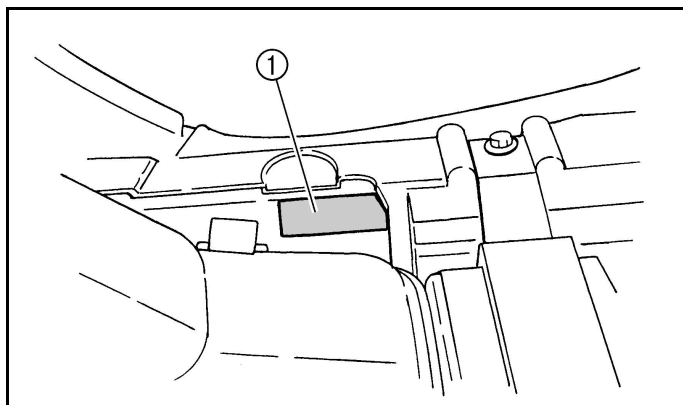

1. Model label

EBU00039

CONTROL FUNCTIONS

⚠ WARNING

Indicates a potential hazard that could result in serious injury or death.

EBU09420

Main switch

Functions of the respective switch positions are as follows:

ON:

The engine can be started only at this position and the headlights and taillight come on when the light switch is on.

OFF:

All electrical circuits are switched off. The key can be removed in this position.

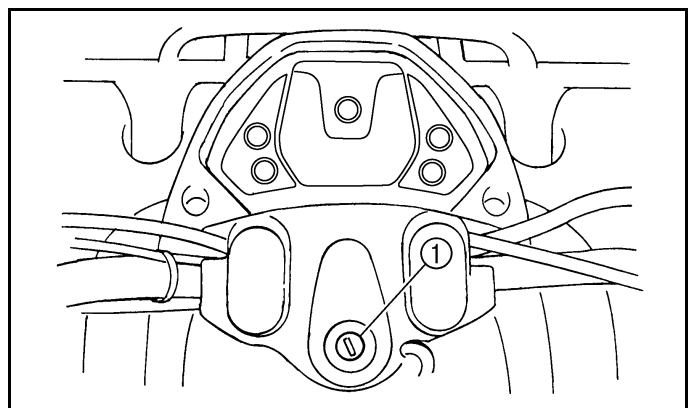

1. Main switch

EBU08020

Indicator and warning lights

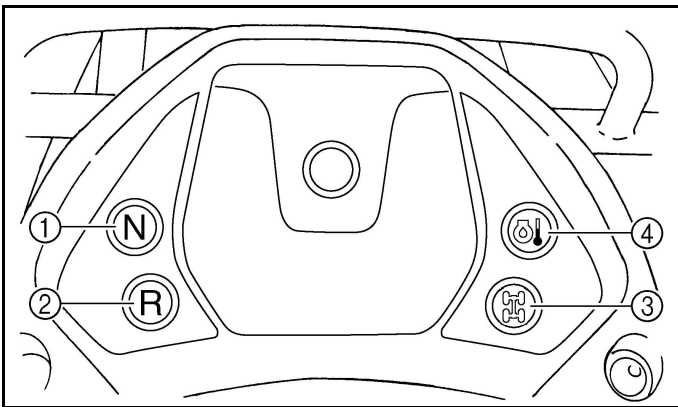

1. Neutral indicator light "N"
2. Reverse indicator light "R"
3. Four-wheel drive indicator light "4x4"
4. Oil temperature warning light "oil can"

EBU09720

Neutral indicator light "N"

This indicator light comes on when the drive select lever is in the "N" position.

EBU12500

Reverse indicator light "R"

This indicator light comes on when the drive select lever is in the "R" position.

EBU00605

Four-wheel-drive indicator light “”

This indicator light comes on when the 2WD/4WD switch is in the 4WD position.

NOTE: _____
Due to the synchronizing mechanism in the differential gear case, the light may not come on until the ATV starts moving.

EBU11400

Oil temperature warning light “”

When the oil temperature reaches a specified level, this light comes on to warn that the engine oil temperature is too hot. If the light comes on during operation, stop the engine as soon as it is safe to do so and allow the engine to cool down for about 10 minutes.

CAUTION: _____

- The engine may overheat if the ATV is overloaded. If this happens, reduce the load to specification.
 - Restart after making sure that the light is out. Continuous use while the light is on may cause damage to the engine.
-

EBU00733

Oil temperature warning light checking method

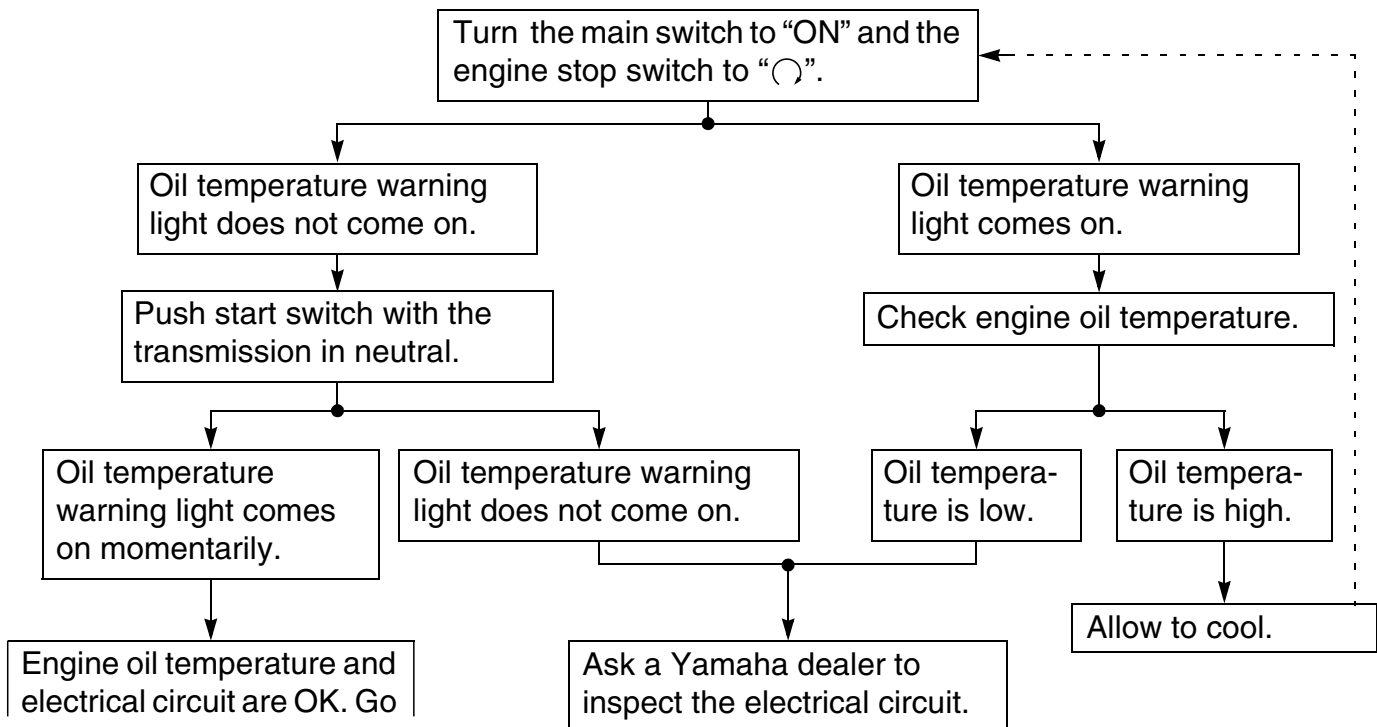

EBU00053

Handlebar switches

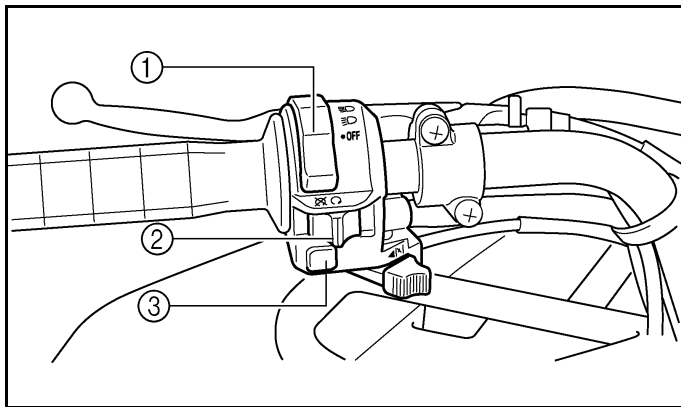

1. Light switch “ \leftarrow / \rightarrow /OFF”
2. Engine stop switch “ \otimes / \ominus ”
3. Start switch “ ⚡ ”

EBU01204

Light switch “ \leftarrow / \rightarrow /OFF”

Set the switch to “ \leftarrow ” to turn on the low beam

CAUTION:

Do not use the headlights with the engine turned off for more than thirty minutes. The battery may discharge to the point that the starter motor will not operate properly. If this should happen, remove the battery and recharge it.

EBU12050

Engine stop switch “ \otimes / \ominus ”

Make sure that the engine stop switch is set to “ \ominus ” before starting the engine. The engine stop switch controls ignition and can be used at all times to stop the engine, especially in an emergency. The engine will not start or run when the engine stop switch is set to “ \otimes ”.

EBU00607

Start switch “”

The starter motor cranks the engine when this switch is pushed.

CAUTION:

See starting instructions prior to starting the engine. (See page 6-1 for details.)

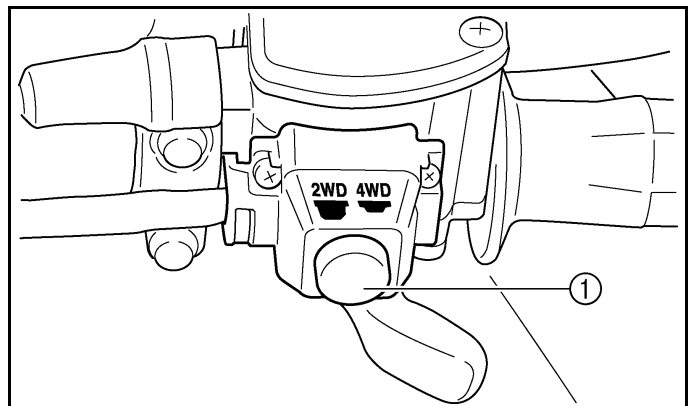

1. Four-wheel drive switch “2WD/4WD”

EBU00601

On-Command four-wheel drive switch “2WD/4WD”

To change from two-wheel drive (2WD) to four-wheel drive (4WD), stop the ATV and set the switch to the 4WD position.

To change from four-wheel drive (4WD) to

 **WARNING**

POTENTIAL HAZARD

Changing from 2WD to 4WD or from 4WD to 2WD while the ATV is moving.

WHAT CAN HAPPEN

The ATV handles differently in 2WD than in 4WD in some circumstances. Changing from 2WD to 4WD or from 4WD to 2WD while moving may cause the ATV to unexpectedly handle differently. This could distract the operator and increase the risk of losing control and an accident.

HOW TO AVOID THE HAZARD

Always stop the ATV before changing from 2WD to 4WD or vice-versa.

EBU00062

Throttle lever

Once the engine is running, movement of the throttle lever will increase the engine speed.

Regulate the speed of the machine by varying the throttle position. Because the throttle is spring-loaded, the machine will decelerate, and the engine will return to an idle any time the hand is removed from the throttle lever.

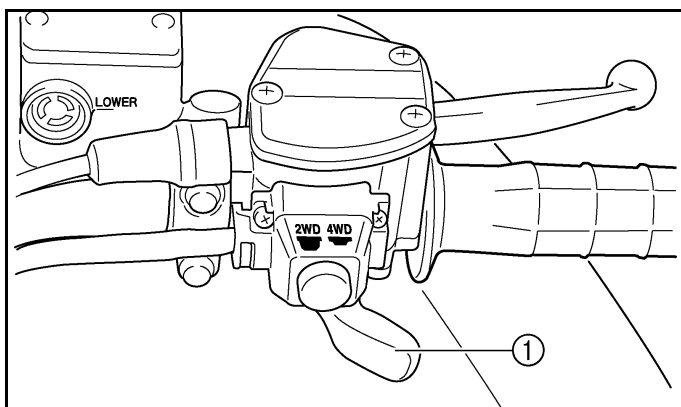

Before starting the engine, check the throttle to be sure it is operating smoothly. Make sure it returns to the idle position as soon as the lever is released.

⚠ WARNING

POTENTIAL HAZARD

Malfunction of throttle.

WHAT CAN HAPPEN

The throttle could be hard to operate, making it difficult to speed up or slow down when you need to. This could cause an accident.

HOW TO AVOID THE HAZARD

Check the operation of the throttle lever before you start the engine. If it does not work smoothly, check for the cause. Correct the problem before riding the ATV. Consult a Yamaha dealer if you

EBU01159

Speed limiter

The speed limiter keeps the throttle from fully opening, even when the throttle lever is pushed to the maximum. Turning in the adjusting screw limits the maximum engine power available and decreases the maximum speed of the ATV.

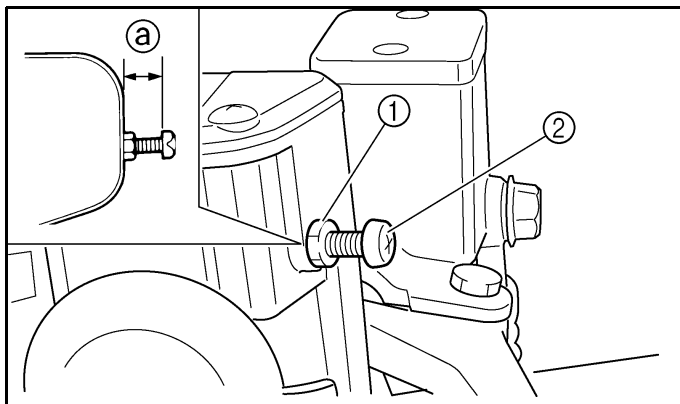

1. Locknut

2. Adjusting screw

WARNING

POTENTIAL HAZARD

Improper adjustment of the speed limiter and throttle.

WHAT CAN HAPPEN

The throttle cable could be damaged. Improper throttle operation could result. You could lose control, have an accident or be injured.

HOW TO AVOID THE HAZARD

Do not turn the adjusting screw out more than 12 mm (0.47 in). Always make sure the throttle lever free play is adjusted to 3–5 mm (0.12–0.20 in). See page 8-26.

EBU00070

Front brake lever

The front brake lever is located on the right handlebar. Pull it toward the handlebar to apply the front brake.

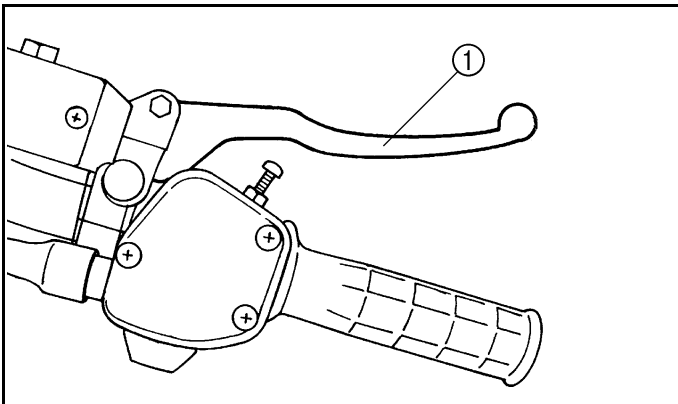

1. Front brake lever

EBU00732

Brake pedal and rear brake lever

he right side of

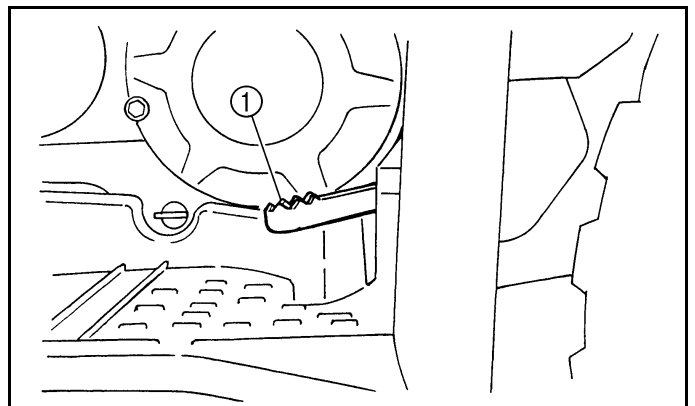

1. Brake pedal

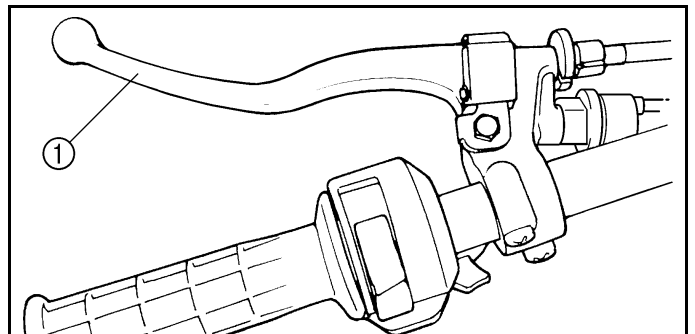

EBU00074

Parking brake

Use the parking brake when you have to start the engine or park the machine, especially on a slope. Apply the rear brake lever and push down the lock plate to apply the parking brake. Squeeze the rear brake lever to release the parking brake.

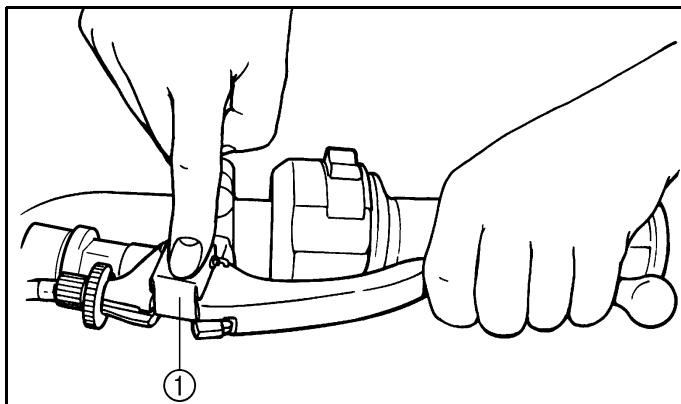

1. Lock plate

⚠ WARNING

POTENTIAL HAZARD

Improper use of the parking brake.

WHAT CAN HAPPEN

The ATV could start moving unexpectedly if the parking brake is not applied before starting the engine. This could cause loss of control or a collision.

The brake could overheat if you ride the ATV without releasing the parking brake. You could lose braking performance which could cause an accident. You could also wear out the brakes prematurely.

HOW TO AVOID THE HAZARD

Always set the parking brake before starting the engine.

Always be sure you have released the

EBU01106

Drive select lever

The drive select lever is used to shift your machine into the forward, neutral and reverse positions. (Refer to page 6-4 for the drive select lever operation.)

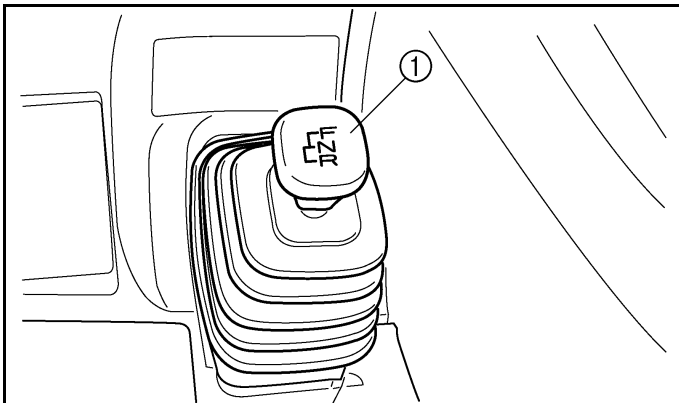

1. Drive select lever

EBU01107

Recoil starter

Firmly grasp the handle and pull slightly until engagement can be felt. Then pull forcefully, being careful not to pull the rope all the way out.

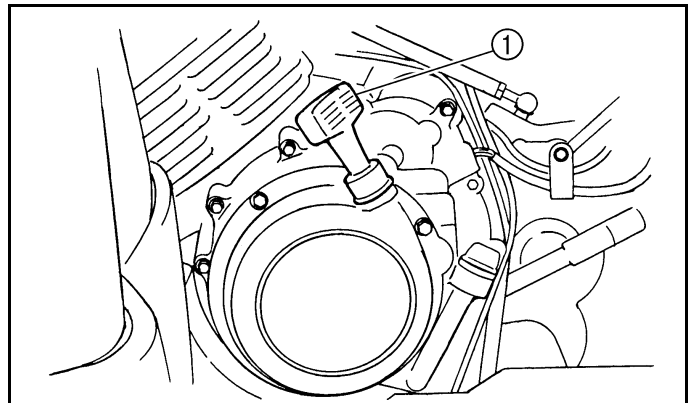

1. Recoil starter

⚠ WARNING

POTENTIAL HAZARD

Starting the engine without shifting into the neutral position.

WHAT CAN HAPPEN

The ATV could start to move unexpectedly, which could cause an accident.

HOW TO AVOID THE HAZARD

Shift the drive select lever into the neutral position and apply the parking brake before starting the engine.

EBU00092

Fuel tank cap

Remove the fuel tank cap by turning it counterclockwise.

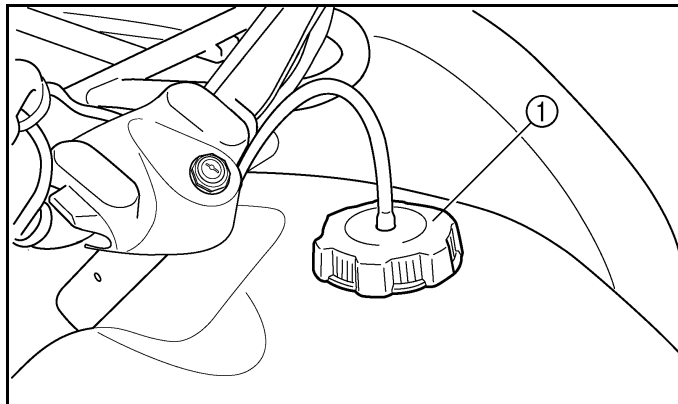

1. Fuel tank cap

EBU00093

Fuel cock

The fuel cock supplies fuel from the fuel tank to the carburetor.

The fuel cock has three positions.

OFF: With the lever in this position fuel will not flow. Always turn the lever to this position when the engine is not running.

ON: With the lever in this position, fuel flows to the carburetor. Normal riding is done with the lever in this position.

RES: This indicates reserve. If you run out of fuel while riding, turn the lever to this position. **THEN FILL THE FUEL TANK AT THE FIRST OPPORTUNITY.** After refuelling, return the fuel cock lever to the "ON" position.

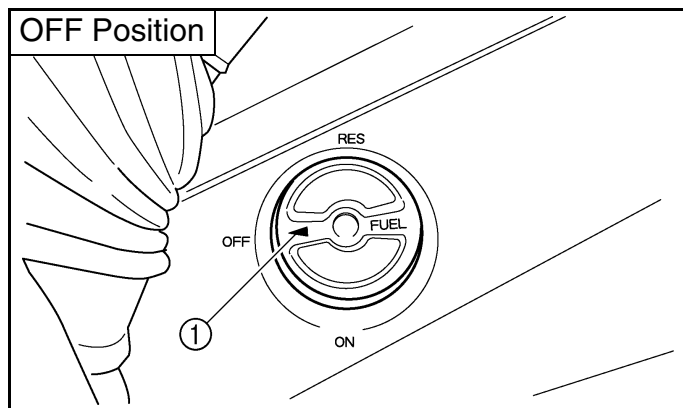

1. Arrow mark pointing to "OFF"

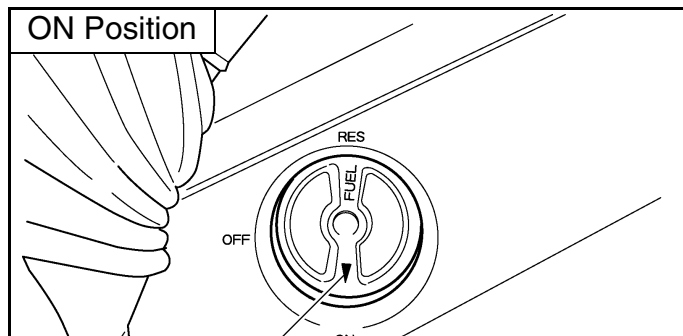

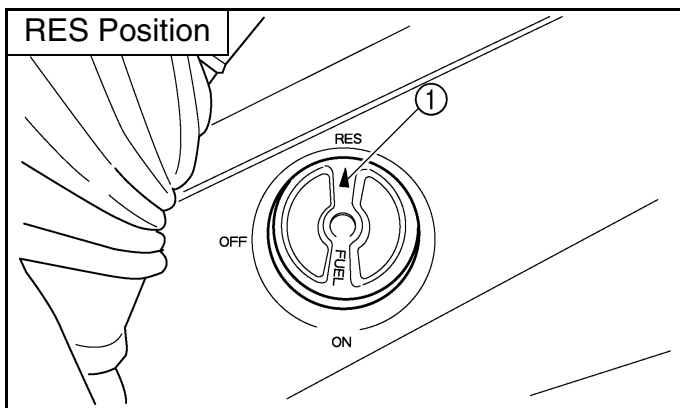

1. Arrow mark pointing to "RES"

EBU00095

Starter (choke) “ ◀ | ▶ ”

Starting a cold engine requires a richer air-fuel mixture. A separate starter circuit supplies this mixture.

Move in direction (a) to turn on the starter (choke).

Move in direction (b) to turn off the starter (choke).

Refer to “Starting a cold engine” for proper operation. (See page 6-1.)

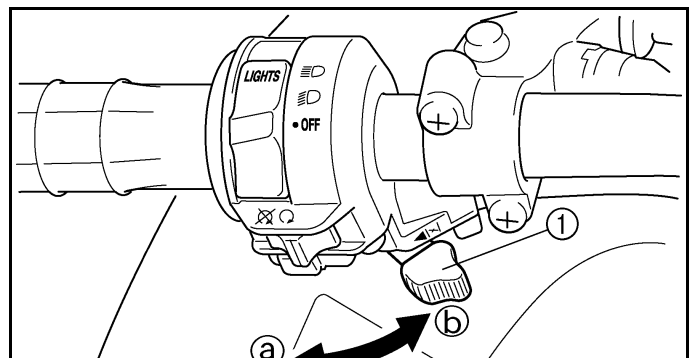

EBU05670

Seat

To remove the seat, pull the seat lock lever upward and pull up the seat at the rear.

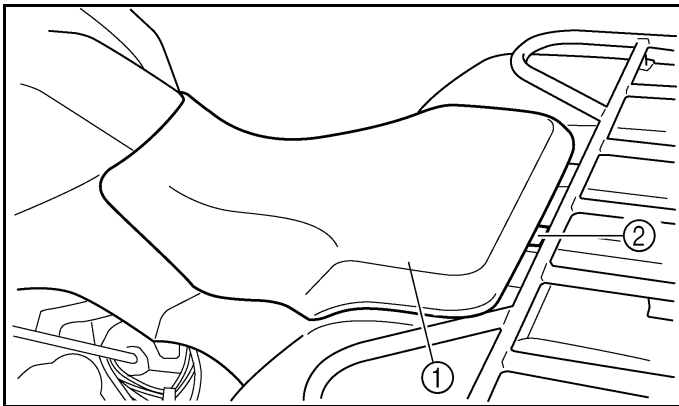

1. Seat

2. Seat lock lever

To install the seat, insert the projections on the front of the seat into the seat holders and push down on the seat at the rear.

NOTE: _____
Make sure that the seat is securely fitted.

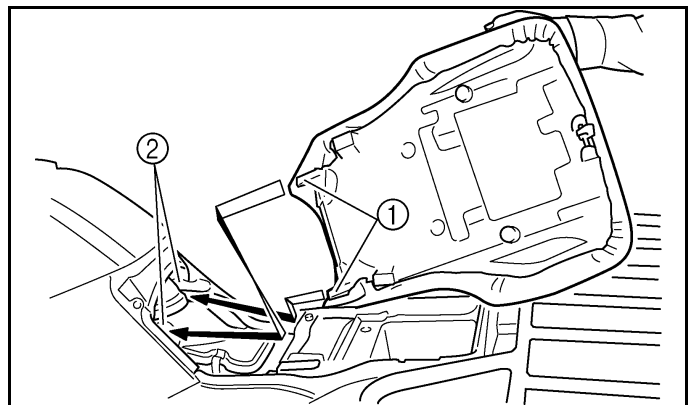

1. Projection (× 2)

2. Seat holder (× 2)

EBU14580

Storage box

Maximum load limit: 2 kg (4.4 lb)

CAUTION:

To protect from damage, do not put metal products, like tools or sharply edged products directly in the storage box. If they must be stored, wrap them in appropriate cushion material.

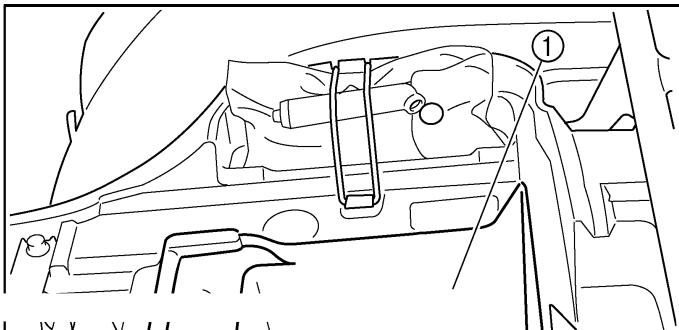

NOTE: There is a check hose at the bottom of the storage box. If any water collects in this hose, remove the hose, empty it, and then install it.

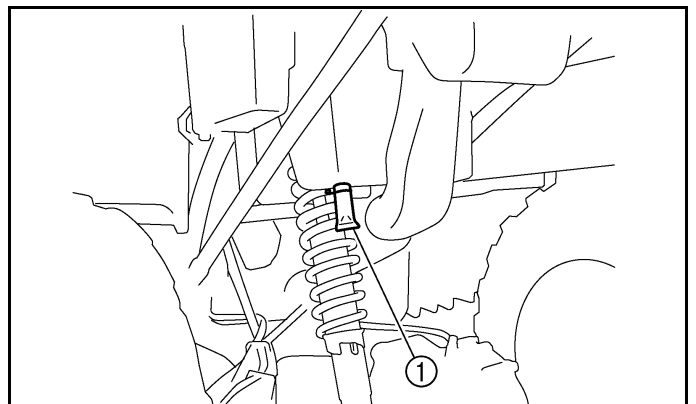

1. Storage box check hose

EBU00582

Front carrier

Maximum load limit: 40 kg (88 lb)

EBU00583

Rear carrier

Maximum load limit: 80 kg (176 lb)

EBU01104

Front shock absorber adjustment

The spring preload can be adjusted to suit the rider's weight and riding conditions.

Adjust the spring preload as follows.

To increase the spring preload, turn the adjusting ring in direction (a).

To decrease the spring preload, turn the ad-



1. Spring preload adjusting ring
2. Position indicator

NOTE: A special wrench can be obtained at a Yamaha dealer to make this adjustment.

Standard position: 2
1 - Minimum (soft)
5 - Maximum (hard)

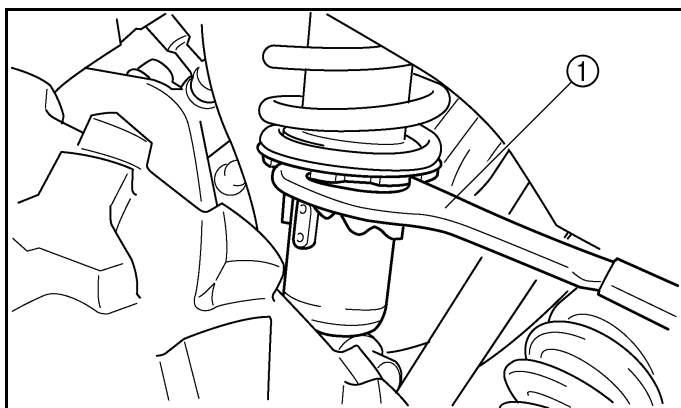

1. Special wrench

⚠ WARNING

POTENTIAL HAZARD

Improper shock absorber adjustment.

WHAT CAN HAPPEN

Uneven adjustment can cause poor handling and loss of stability, which

EBU01103

Rear shock absorber adjustment

The spring preload can be adjusted to suit the rider's weight and riding conditions.

Adjust the spring preload as follows:

To increase the spring preload, turn the adjusting ring in direction **Ⓐ**.

To decrease the spring preload, turn the adjusting ring in direction **Ⓑ**.

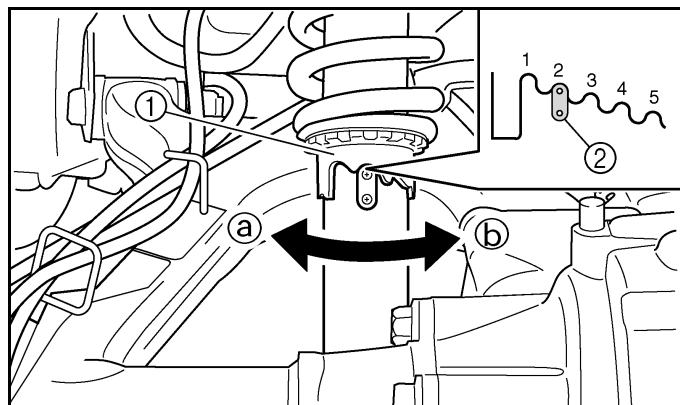

1. Spring preload adjusting ring

NOTE:

A special wrench can be obtained at a Yamaha dealer to make this adjustment.

Standard position: 2

1 - Minimum (soft)

5 - Maximum (hard)

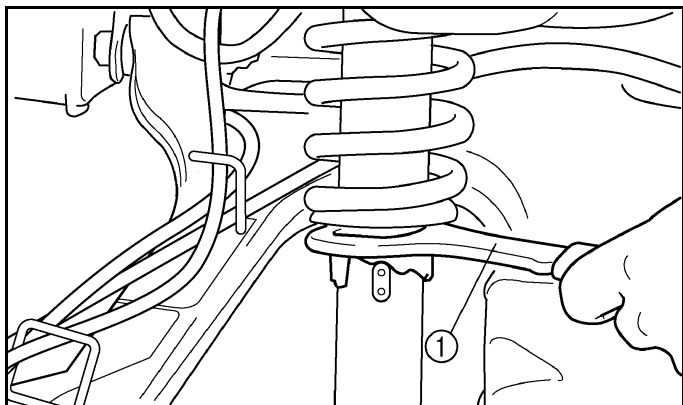

PRE-OPERATION CHECKS

Before using this machine, check the following points:

ITEM	ROUTINE	PAGE
Front brake	<ul style="list-style-type: none"> • Check operation, free play, fluid level and fluid leakage. • Fill with DOT 4 brake fluid if necessary. 	5-2-5-3, 8-27-8-30
Rear brake	<ul style="list-style-type: none"> • Check operation, condition and free play. • Adjust if necessary. 	5-2-5-3, 8-27,8-31-8-33
Fuel	<ul style="list-style-type: none"> • Check fuel level. • Fill with fuel if necessary. 	5-4-5-5
Engine oil	<ul style="list-style-type: none"> • Check oil level. • Fill with oil if necessary. 	5-6, 8-6-8-11
Final gear oil/ differential gear oil	<ul style="list-style-type: none"> • Check for leakage. 	5-6-5-7, 8-11-8-15
Throttle	<ul style="list-style-type: none"> • Check for proper throttle cable operation. 	5-7, 8-26
Wheels and tires	<ul style="list-style-type: none"> • Check tire pressure, wear and damage. 	5-8-5-11, 8-36-8-37
Fittings and fasteners	<ul style="list-style-type: none"> • Check all fittings and fasteners. 	5-7
	for proper operation.	5-7, 8-34, 8-41-8-45

 **WARNING**

POTENTIAL HAZARD

Failure to inspect the ATV before operating.

Failure to properly maintain the ATV.

WHAT CAN HAPPEN

Increases the possibility of an accident or equipment damage.

HOW TO AVOID THE HAZARD

Always inspect your ATV each time you use it to make sure the ATV is in safe operating condition.

Always follow the inspection and maintenance procedures and schedules described in the Owner's Manual.

EBU12521

Front and rear brakes

Brake levers and brake pedal

- Check for correct free play in the front brake lever. If the free play is incorrect, have a Yamaha dealer adjust it.
- Check for correct free play in the rear brake lever and brake pedal. If the free play is incorrect, adjust it. (See pages 8-31–8-33.)
- Check operation of the levers and pedal. They should move smoothly and there should be a firm feeling when the brake is applied. If not, have a Yamaha dealer inspect them.

Brake fluid level (front brake)

Check the brake fluid level. Add fluid if necessary. (See pages 8-28–8-29.)

Recommended brake fluid: DOT 4

Brake fluid leakage (front brake)

Check to see if any brake fluid is leaking out of the hose, joint or brake fluid reservoir of the front brake. Apply the brake firmly for one minute. If the lever moves slowly inward, there may be a leak in the brake system. If there is any leakage, the brake system should be inspected by a Yamaha dealer.

Brake operation

Test the brakes at slow speed after starting out to make sure they are working properly. If the brakes do not provide proper braking performance, inspect the brake pads and shoes for wear. (See page 8-27.)

⚠ WARNING

POTENTIAL HAZARD

Riding with improperly operating brakes.

WHAT CAN HAPPEN

You could lose braking ability, which could lead to an accident.

HOW TO AVOID THE HAZARD

Always check the brakes at the start of every ride. Do not ride the ATV if you find any problem with the brakes. If a problem cannot be corrected by the adjustment procedures provided in this manual, have a Yamaha dealer check for the cause.

EBU01085

Fuel

Make sure there is sufficient gasoline in the tank.

Recommended fuel:

UNLEADED GASOLINE ONLY

Fuel tank capacity:

Total:

13.5 L (2.97 Imp gal, 3.57 US gal)

Reserve:

3.3 L (0.73 Imp gal, 0.87 US gal)

Your Yamaha engine has been designed to use regular unleaded gasoline with a pump octane number $([R+M]/2)$ of 86 or higher, or research octane number of 91 or higher. If knocking or pinging occurs, use a different brand of gasoline or premium unleaded fuel. Unleaded fuel will give you longer spark plug life and reduced maintenance cost.

CAUTION:

Use only unleaded gasoline. The use of leaded gasoline will cause severe damage to internal engine parts, such as the valves and piston rings, as well as to the exhaust system.

Gasohol

There are two types of gasohol; gasohol containing ethanol and that containing methanol. Gasohol containing ethanol can be used if ethanol content does not exceed 10%. Gasohol containing methanol is not recommended by Yamaha because it may cause fuel system damage or vehicle performance problems.

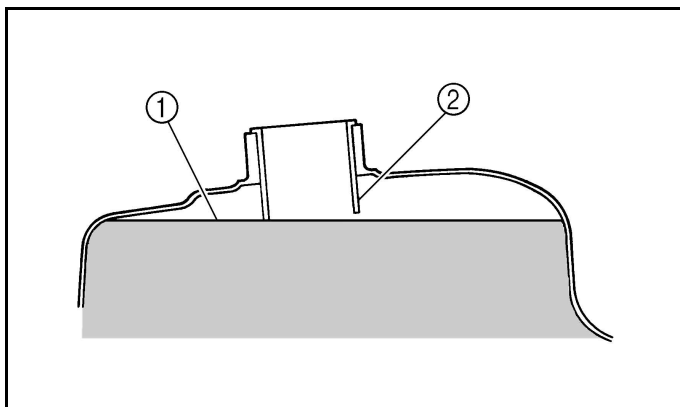

nk filler tube

⚠ WARNING

POTENTIAL HAZARD

Improper care when refueling.

WHAT CAN HAPPEN

Fuel can spill, which can cause a fire and severe injury. Fuel expands when it heats up. If the fuel tank is overfilled, fuel could spill out due to heat from the engine or the sun.

HOW TO AVOID THE HAZARD

Do not overfill the fuel tank. Be careful not to spill fuel, especially on the engine or exhaust pipe. Wipe up any spilled fuel immediately. Be sure the fuel tank cap is closed securely. Do not refuel right after the engine has been running and is still very hot.

EBU10842

Engine oil

Make sure the engine oil is at the specified level. Add oil as necessary. (See pages 8-6–8-11.)

CAUTION:

- In order to prevent clutch slippage (since the engine oil also lubricates the clutch), do not mix any chemical additives. Do not use oils with a diesel specification of “CD” or oils of a higher quality than specified. In addition, do not use oils labeled “ENERGY CONSERVING II” or higher.
- Make sure that no foreign material enters the crankcase.

EBU00493

Final gear oil

Make sure the final gear oil is at the specified level. Add oil as necessary. (See pages 8-11–8-13 for details.)

Recommended oil:

SAE 80 API GL-4 Hypoid gear oil

If desired, an SAE 80W90 hypoid gear oil may be used for all conditions.

NOTE:

GL-4 is a quality and additive rating, GL-5 or GL-6 rated hypoid gear oils may also be used.

Recommended engine oil type and

EBU00678

Differential gear oil

Make sure the differential gear oil is at the specified level. Add oil as necessary. (See pages 8-14–8-15 for details.)

Recommended oil: SAE 80 API GL-4 Hypoid gear oil

EBU01083

Throttle lever

Check to see that the throttle lever operates correctly. It must open smoothly and spring back to the idle position when released. Have a Yamaha dealer repair as necessary for proper operation.

EBU11620

Fittings and fasteners

Always check the tightness of chassis fittings and fasteners before a ride. Take the machine to a Yamaha dealer or refer to the Service Manual for correct tightening torque.

EBU10030

Lights

Check the headlights and tail/brake light to make sure they are in working condition. Repair as necessary for proper operation.

EBU11700

Switches

Check the operation of all switches. Have a Yamaha dealer repair as necessary for proper operation.

EBU00157

Tires

WARNING

POTENTIAL HAZARD

Operating this ATV with improper tires, or with improper or uneven tire pressure.

WHAT CAN HAPPEN

Use of improper tires on this ATV, or operation of this ATV with improper or uneven tire pressure, may cause loss of control, increasing your risk of accident.

HOW TO AVOID THE HAZARD

1. The tires listed below have been approved by Yamaha Motor Co., Ltd. for this model. Other tire combinations are not recommended.

2. The tires should be set to the recommended pressure:

- Recommended tire pressure
Front 25 kPa (0.25 kgf/cm², 3.6 psi)
Rear 25 kPa (0.25 kgf/cm², 3.6 psi)
- Check and adjust tire pressures when the tires are cold.
- Tire pressures must be equal on both sides.

3. Tire pressure below the minimum specified could cause the tire to dislodge from the rim under severe riding conditions.

The following are minimums:
Front 22 kPa (0.22 kgf/cm², 3.2 psi)
Rear 22 kPa (0.22 kgf/cm², 3.2 psi)

4. Use no more than the following pressures when seating the tire beads.

Front 250 kPa (2.5 kgf/cm², 36 psi)

Rear 250 kPa (2.5 kgf/cm², 36 psi)

Higher pressures may cause the tire to burst. Inflate the tires very slowly and carefully. Fast inflation could cause the tire to burst.

EBU00159

How to measure tire pressure

Use the low-pressure tire gauge.

NOTE: _____

The low-pressure tire gauge is included as standard equipment. Make two measurements of the tire pressure and use the second reading. Dust or dirt in the gauge could cause the first reading to be incorrect.

Set pressure with tires cold.

Set tire pressures to the following specifications:

	Recommended pressure	Minimum	Maximum
Front	25 kPa (0.25 kgf/cm ² , 3.6 psi)	22 kPa (0.22 kgf/cm ² , 3.2 psi)	28 kPa (0.28 kgf/cm ² , 4.0 psi)
Left Rear	(0.25 kgf/cm ²)	(0.22 kgf/cm ²)	28 kPa (0.28 kgf/cm ²)

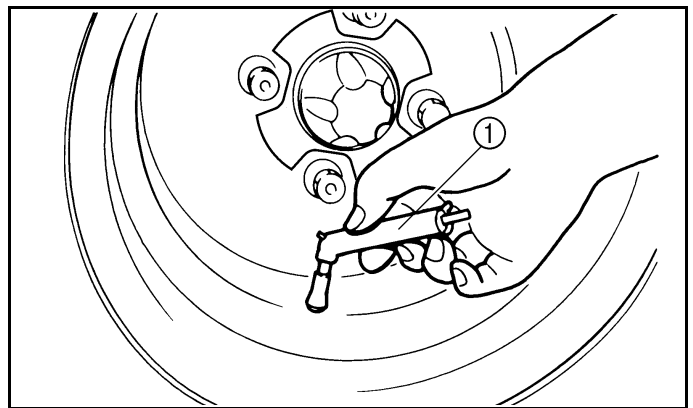

1. Low-pressure tire gauge

EBU00160

Tire wear limit

When the tire groove decreases to 3 mm (0.12 in) due to wear, replace the tire.

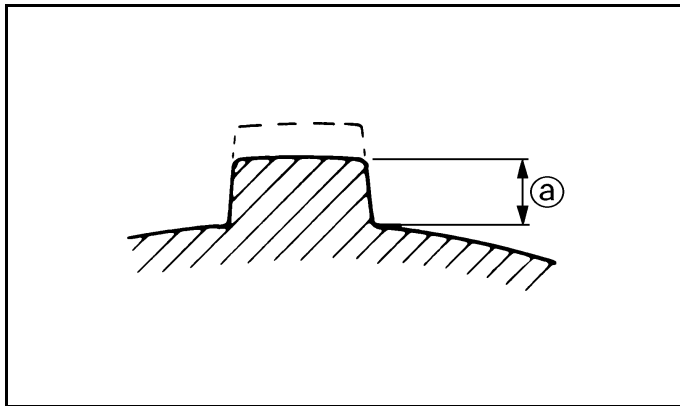

a. Tire wear limit

EBU00161

OPERATION

WARNING

Indicates a potential hazard that could result in serious injury or death.

WARNING

POTENTIAL HAZARD

Operating ATV without being familiar with all controls.

WHAT CAN HAPPEN

Loss of control, which could cause an accident or injury.

HOW TO AVOID THE HAZARD

Read the Owner's Manual carefully. If there is a control or function you do not understand, ask your Yamaha dealer.

EBU14590

Starting a cold engine

WARNING

POTENTIAL HAZARD

Freezing control cables in cold weather.

WHAT CAN HAPPEN

You could be unable to control the ATV, which could lead to an accident or collision.

HOW TO AVOID THE HAZARD

When riding in cold weather, always make sure all control cables work smoothly before you begin riding.

1. Apply the brake pedal.
2. Turn the fuel cock to "ON".
3. Turn the main switch to "ON" and the engine stop switch to "⊙".
4. Shift the drive select lever into the neutral

NOTE:

- When the drive select lever is in the neutral position, the neutral indicator light should come on. If it does not come on, ask a Yamaha dealer to inspect the electric circuit.
- The engine can be started in any gear if the brake pedal is applied. However, it is recommended to shift into neutral before starting the engine.

5. Use the starter (choke) in reference to the figure:

Position ①: Cold engine start-ambient temperature below 5 °C (40 °F).

Position ②: Cold engine start-ambient temperature at 0 °C (°F) and warm-

Position ③: Cold engine start-ambient temperature above 25 °C (80 °F) and warm engine start position.

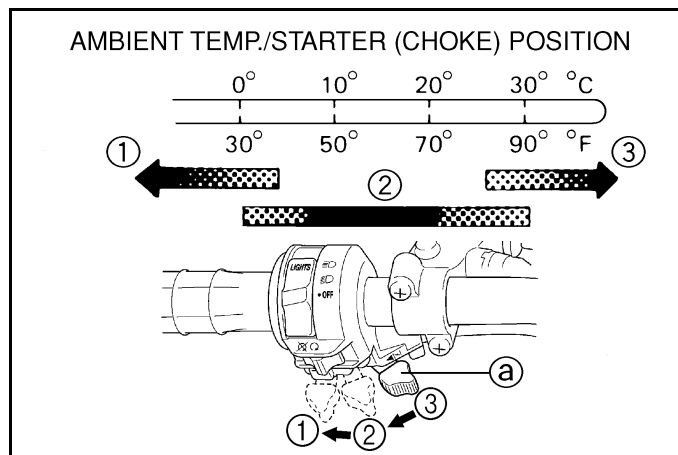

- a. Starter (choke)
1. Fully open
 2. Half open
 3. Closed

6. Completely close the throttle lever and start the engine by pushing the start

NOTE:

- If the engine fails to start, release the start switch, then push the start switch again. Pause a few seconds before the next attempt. Each cranking should be as short as possible to preserve battery energy. Do not crank the engine more than 10 seconds on each attempt.
- If the battery is discharged, pull the recoil starter to start the engine.

7. If the engine is started with the starter (choke) in position ①, the starter (choke) should be returned to position ② to warm up the engine. If the engine is started with the starter (choke) in position ②, keep the starter (choke) in this position to warm up the engine.

engine until it

CAUTION:

See the “Engine break-in” section prior to operating the engine for the first time.

EBU00180

Starting a warm engine

To start a warm engine, refer to the “Starting a cold engine” section. The starter (choke) should not be used. The throttle should be opened slightly.

EBU00182

Warming up

To get maximum engine life, always warm up the engine before starting off. Never accelerate hard with a cold engine! To see whether or not the engine is warm, check if it responds to the throttle normally with the starter (choke)

EBU14600

Drive select lever operation and reverse driving

CAUTION:

Before shifting, stop the machine and return the throttle lever to its closed position. Otherwise, the transmission may be damaged.

Shifting: forward

1. Bring the machine to a complete stop and return the throttle lever to the closed position.
2. Shift the gear from neutral to forward and vice versa by moving the drive select lever along the shift guide.

NOTE:

Make sure that the drive select lever is com-

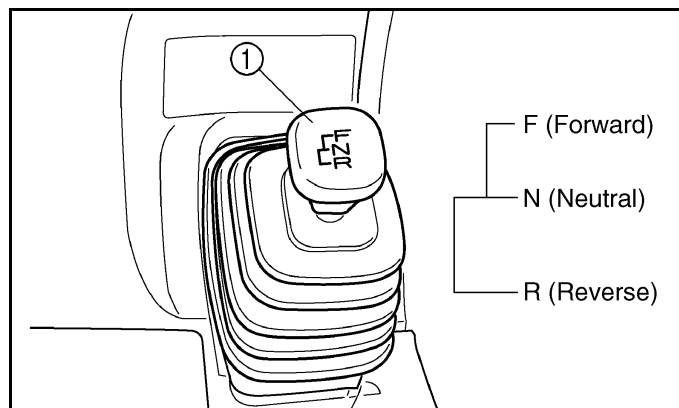

1. Drive select lever

3. Open the throttle lever gradually.

Shifting: reverse

1. Bring the machine to a complete stop and return the throttle lever to the closed position.
2. Apply the brake pedal.
3. Shift the gear from neutral to reverse and vice versa by moving the drive select lever along the shift guide.

NOTE:

When in reverse, the reverse indicator light should be on. If the light does not come on, ask a Yamaha dealer to inspect the ATV.

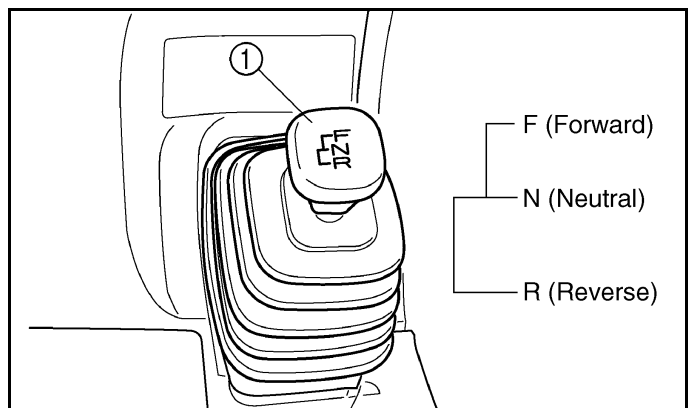

1. Drive select lever
4. Check behind for people or obstacles, then release the brake pedal.
5. Open the throttle lever gradually and continue to watch to the rear while backing.

 **WARNING**

POTENTIAL HAZARD

Improper operation in reverse.

WHAT CAN HAPPEN

You could hit an obstacle or person behind you, resulting in serious injury.

HOW TO AVOID THE HAZARD

When you shift into reverse, make sure there are no obstacles or people behind you. When it is safe to proceed, go slowly.

EBU02101

Engine break-in

There is never a more important period in the life of your machine than the period between zero and 20 hours.

For this reason, we ask that you carefully read the following material. Because the engine is brand new, you must not put an excessive load on it for the first several hours of running. During the first 20 hours, the various parts in the engine wear and polish themselves to the correct operating clearances.

During this period, prolonged full throttle operation or any condition which might result in excessive engine heating must be avoided. However, momentary (2–3 seconds maximum) full throttle operation under load does not harm the engine.

Each full throttle acceleration sequence should be followed with a substantial rest period for the engine by cruising at lower r/min so the engine can rid itself of the temporary build up of heat.

If any abnormality is noticed during this period, consult a Yamaha dealer.

0–10 hours:

Avoid continuous operation above half throttle. Allow a cooling off period of five to ten minutes after every hour of operation. Vary the speed of the machine from time to time. Do not operate it at one set throttle position.

10–20 hours:

Avoid prolonged operation above 3/4 throttle. Rev the machine freely but do not use full throttle at any time.

After break-in:

Avoid prolonged full throttle operation. Vary speeds occasionally.

EBU00211

Parking

When parking, stop the engine and shift into neutral. Turn the fuel cock to “OFF” and apply the parking brake.

EBU13750

Parking on a slope

WARNING

POTENTIAL HAZARD

Parking on a hill or other incline.

WHAT CAN HAPPEN

The ATV could roll out of control, increasing the chance of an accident.

HOW TO AVOID THE HAZARD

Avoid parking on hills or other inclines. If you must park on an incline, place the machine transversely across the incline, apply the parking brake, and block the front and rear wheels with rocks or other objects.

Do not park the ATV at all on hills that are so steep you could not walk up them easily.

1. Bring the machine to a stop by applying the brakes.
2. Stop the engine.
3. With the rear brake lever and pedal applied, apply the parking brake, and then slowly release the brake pedal.

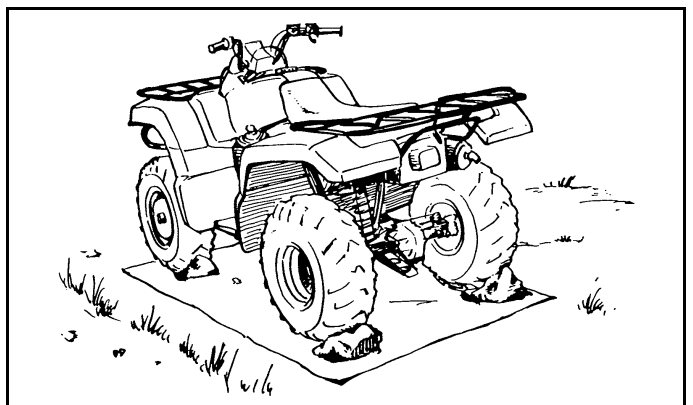

EBU00221

Accessories and loading

EBU00222

Accessories

Accessories can affect the handling and control of your ATV. Keep the following in mind when considering an accessory or operating an ATV which has accessories.

- Choose only accessories designed for your ATV. Your Yamaha dealer has a variety of genuine Yamaha accessories. Other accessories may also be available on the market. However, it is not possible for Yamaha to test all non-Yamaha accessories, nor have any control over the quality or suitability of them. Choose a genuine Yamaha accessory, or one that is equivalent in design and quality.
- Accessories should be rigidly and securely mounted. An accessory which can shift position or come off while you are riding could affect your ability to control the ATV.
- Do not mount an accessory where it could interfere with your ability to control the ATV. Examples include (but are not limited to) a heavy or bulky object attached to the handlebars which could make steering difficult, an accessory that limits your ability to move around on the seat, or one that limits your view.
- Use extra caution when riding an ATV with accessories. The ATV may handle differently than it does without accessories.

EBU12461

Loading

Cargo or a trailer can change the stability and handling of an ATV.

You must use common sense and good judgment when carrying cargo or towing a trailer. Keep the following points in mind:

- Never exceed the weight limits shown. An overloaded ATV can be unstable.

MAXIMUM LOADING LIMIT

- Vehicle loading limit (total weight of cargo, rider and accessories, and tongue weight): 210 kg (463 lb)
- Front carrier: 40 kg (88 lb)
- Rear carrier: 80 kg (176 lb)
- Storage box: 2.0 kg (4.4 lb)
- Trailer hitch:
Pulling load (total weight of trailer lbf)

- Do not exceed the maximum tongue weight. You can measure tongue weight with a bathroom scale. Put the tongue of the loaded trailer on the scale with the tongue at hitch height. Adjust the load in the trailer, if necessary, to reduce the weight on hitch.

If you are carrying cargo and towing a trailer, include the tongue weight in the maximum vehicle load limit.

- Load cargo on the carrier as close to the center of the vehicle as possible. Put cargo at the rear of the front carrier and at the front of the rear carrier. Center the load from side to side.
- Tie down cargo securely to the carriers. Make sure cargo in the trailer cannot move around. A shifting load can cause an accident.

- Ride more slowly than you would without a load. The more weight you carry, the slower you should go.
- Allow more braking distance. A heavier vehicle takes longer to stop.
- Avoid making sharp turns unless at very slow speeds.
- Avoid hills and rough terrain. Choose terrain carefully. Added weight affects the stability and handling of the ATV.

 **WARNING**

POTENTIAL HAZARD

Overloading this ATV or carrying or towing cargo improperly.

WHAT CAN HAPPEN

Could cause changes in vehicle handling which could lead to an accident.

HOW TO AVOID THE HAZARD

Never exceed the stated load capacity for this ATV.

Cargo should be properly distributed and securely attached.

Reduce speed when carrying cargo or pulling a trailer. Allow greater distance for braking.

EBU14610

 **WARNING**

Indicates a potential hazard that could result in serious injury or death.

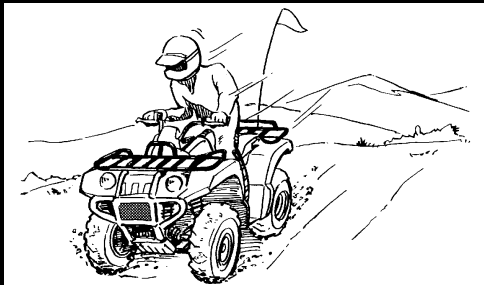
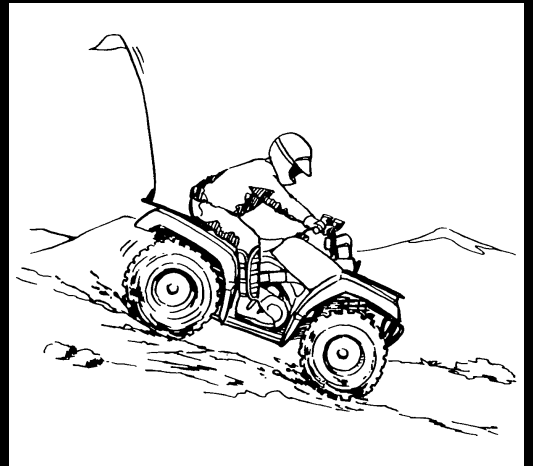
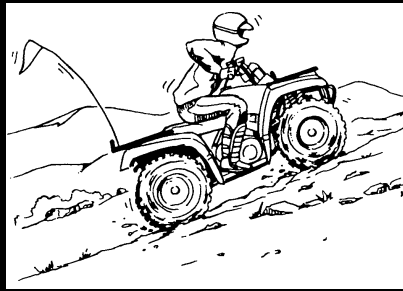
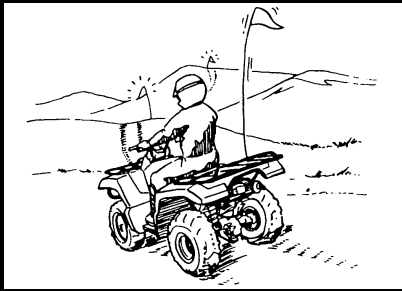

Riding Your ATV

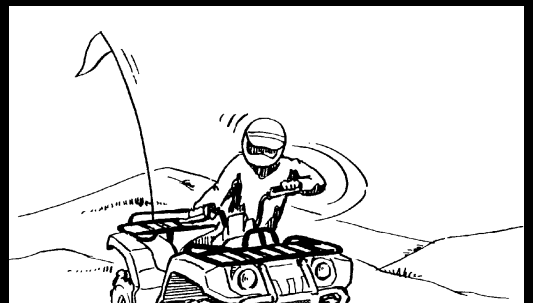

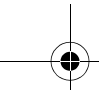

 **WARNING**

Indicates a potential hazard that could result in serious injury or death.

GETTING TO KNOW YOUR ATV

This ATV is for recreation and utility use. This section, Riding your ATV, provides general ATV riding instructions for recreational riding. The skills and techniques described in this section, however, are appropriate for all types of riding. Riding your ATV requires special skills acquired through practice over a period of time. Take the time to learn the basic techniques well before attempting more difficult maneuvers.

Riding your new ATV can be a very enjoyable
rs of pleasure.

Owner's Manual completely and understand the operation of the controls. Pay particular attention to the safety information on pages 2-1–2-6. Please also read all caution and warning labels on your ATV.

RIDE WITH CARE AND GOOD JUDGEMENT

Get training if you are inexperienced.

Beginners should get training from a certified instructor.

Become familiar with this ATV at slow speeds first, even if you are an experienced operator. Do not attempt to operate at maximum performance until you are totally familiar with the ATV's handling and performance characteristics.



WARNING

POTENTIAL HAZARD

Operating this ATV without proper instruction.

WHAT CAN HAPPEN

greatly in-

HOW TO AVOID THE HAZARD

Beginning and inexperienced operators should complete the certified training course offered by Yamaha. They should then regularly practice the skills learned in the course and the operating techniques described in this Owner's Manual. For more information about the training course, contact an authorized ATV dealer or call 1-800-887-2887.

Riding your ATV requires skills acquired through practice over a period of time.

Take the time to learn the basic techniques well before attempting more difficult maneuvers.

Not recommended for children under 16 years of age.

⚠ WARNING

POTENTIAL HAZARD

Failure to follow the age recommendations for this ATV.

WHAT CAN HAPPEN

Use by children of ATVs that are not recommended for their age can lead to severe injury or death of the child.

HOW TO AVOID THE HAZARD

A child under 16 should never operate an ATV with engine size greater than 90 cc.



This ATV is designed to carry operator and cargo only – passengers prohibited.

⚠ WARNING

POTENTIAL HAZARD

Carrying a passenger on this ATV.

WHAT CAN HAPPEN

Greatly reduces your ability to balance and control this ATV. Could cause an accident, resulting in harm to you and/or your passenger.

HOW TO AVOID THE HAZARD

Never carry a passenger. The long seat is to allow the operator to shift position as needed during operation. It is not for carrying passengers.

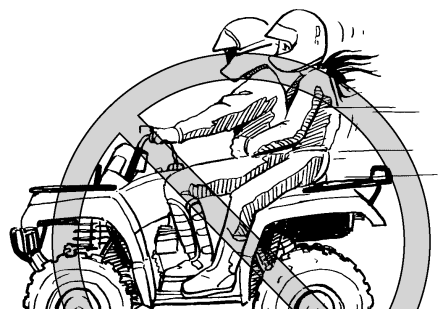

Apparel

WARNING

POTENTIAL HAZARD

Operating this ATV without wearing an approved motorcycle helmet, eye protection and protective clothing.

WHAT CAN HAPPEN

Operating without an approved motorcycle helmet increases your chances of a severe head injury or death in the event of an accident.

Operating without eye protection can result in an accident and increases your chances of a severe eye injury in the event of an accident.

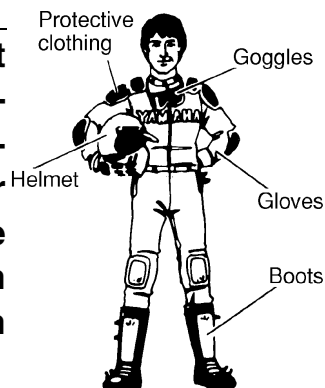

Operating without protective clothing increases your chances of severe injury in the event of an accident.

HOW TO AVOID THE HAZARD

Always wear an approved motorcycle helmet that fits properly.

You should also wear:

- eye protection
(goggles or face shield)
- gloves
- boots
- long-sleeved shirt or jacket
- long pants

Do not operate after consuming alcohol or drugs.

Operator's performance capability is reduced by the influence of alcohol or drugs.



⚠ WARNING

POTENTIAL HAZARD

Operating this ATV after consuming alcohol or drugs.

WHAT CAN HAPPEN

**Could seriously affect your judgment.
Could cause you to react more slowly.
Could affect your balance and perception.**

Could result in an accident.

HOW TO AVOID THE HAZARD

Never consume alcohol or drugs before or while driving this ATV.

Pre-operation checks

Always perform the pre-operation checks listed on page 5-1 before riding for safety and proper care of the ATV.

WARNING

POTENTIAL HAZARD

Failure to inspect the ATV before operating.

Failure to properly maintain the ATV.

WHAT CAN HAPPEN

Increases the possibility of an accident or equipment damage.

HOW TO AVOID THE HAZARD

Always inspect your ATV each time you use it to make sure the ATV is in safe operating condition. Always follow the inspection and maintenance procedures the Owner's

WARNING

POTENTIAL HAZARD

Operating this ATV with improper tires, or with improper or uneven tire pressure.

WHAT CAN HAPPEN

Use of improper tires on this ATV, or operation of this ATV with improper or uneven tire pressure, may cause loss of control, increasing your risk of an accident.

HOW TO AVOID THE HAZARD

Always use the size and type tires specified in the Owner's Manual for this vehicle on pages 5-8–5-9. Always maintain proper tire pressure as described in the Owner's Manual on page 5-10.

⚠ WARNING

Indicates a potential hazard that could result in serious injury or death.

Do not operate at speeds too fast for your skills or the conditions.

⚠ WARNING

POTENTIAL HAZARD

Operating this ATV at speeds too fast for your skills or the conditions.

WHAT CAN HAPPEN

Increases your chances of losing control of the ATV, which can result in an accident.

HOW TO AVOID THE HAZARD

Always go at a speed that is proper for operating con-

Speed limiter

For riders less experienced with this model, this model is equipped with a speed limiter in the throttle lever housing. The speed limiter keeps the throttle from fully opening, even when the throttle lever is pushed to the maximum. Turning the adjusting screw in limits the maximum engine power available and decreases the maximum speed of the ATV. Turning the adjusting screw in decreases top speed and turning it out increases top speed.

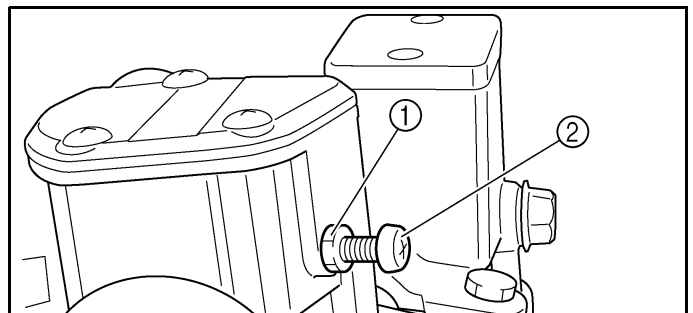

Loading and accessories

Use extra caution when riding the ATV with additional loads, such as accessories or cargo. The ATV's handling may be adversely affected. Reduce your speed when adding additional loads.

MAXIMUM LOADING LIMIT

- Vehicle loading limit: 210 kg (463 lb)
 - * Total weight of cargo, rider and accessories, and trailer hitch vertical load.
- Front carrier: 40 kg (88 lb)
- Rear carrier: 80 kg (176 lb)
- Storage box: 2.0 kg (4.4 lb)
- Trailer hitch:
 - Pulling load: 500 kgf (1,102 lbf)
 - Total weight of trailer and cargo. lbf)

WARNING

POTENTIAL HAZARD

Overloading this ATV or carrying or towing cargo improperly.

WHAT CAN HAPPEN

Could cause changes in vehicle handling which could lead to an accident.

HOW TO AVOID THE HAZARD

Never exceed the stated load capacity for this ATV.

Cargo should be properly distributed and securely attached.

Reduce speed when carrying cargo or pulling a trailer. Allow greater distance for braking.

Always follow the instructions in your Owner's Manual for carrying cargo or pulling a trailer.

During operation

Always keep your feet on the footboards during operation. Otherwise your feet may contact the rear wheels.

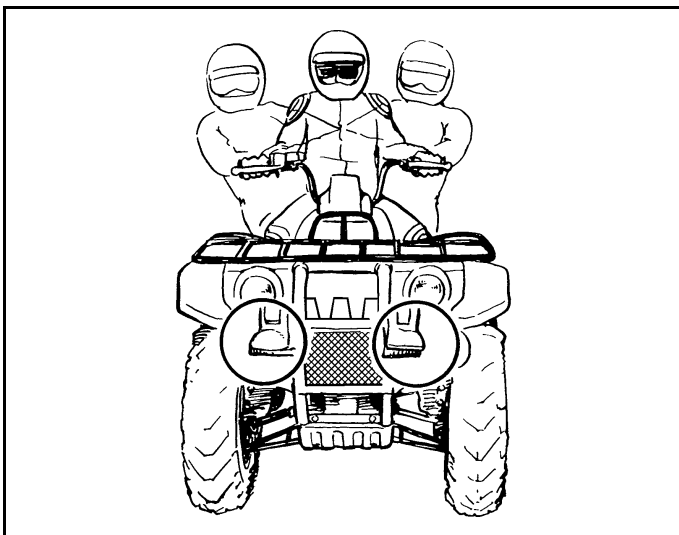

⚠ WARNING

POTENTIAL HAZARD

Removing hands from handlebars or feet from footboards during operation.

WHAT CAN HAPPEN

Removing even one hand or foot can reduce your ability to control the ATV or could cause you to lose your balance and fall off of the ATV. If you remove a foot from a footboard, your foot or leg may come into contact with the rear wheels, which could injure you or cause an accident.

HOW TO AVOID THE HAZARD

Always keep both hands on the handlebars and both feet on the footboards of your ATV during operation.

Avoid wheelies and jumping. You may lose control of the ATV or overturn.

⚠ WARNING

POTENTIAL HAZARD

Attempting wheelies, jumps, and other stunts.

WHAT CAN HAPPEN

Increases the chance of an accident, including an overturn.

HOW TO AVOID THE HAZARD

Never attempt stunts, such as wheelies or jumps. Don't try to show off.

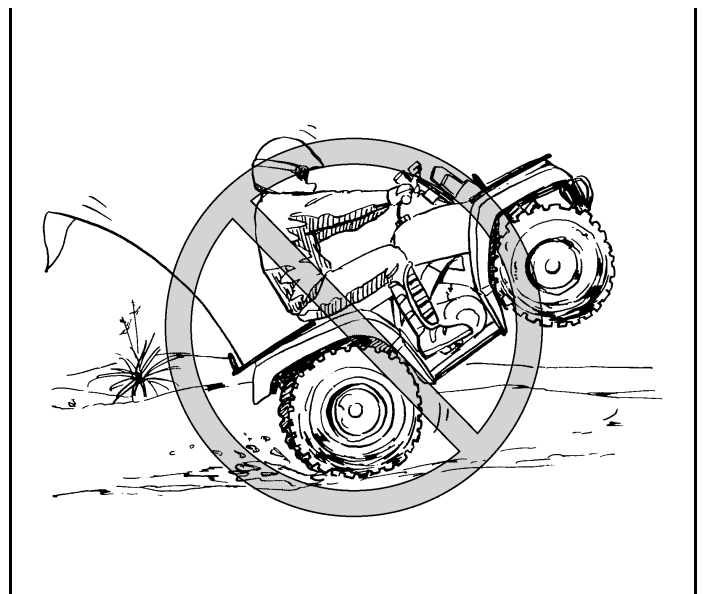

Modifications

WARNING

POTENTIAL HAZARD

Operating this ATV with improper modifications.

WHAT CAN HAPPEN

Improper installation of accessories or modification of this vehicle may cause changes in handling which in some situations could lead to an accident.

HOW TO AVOID THE HAZARD

Never modify this ATV through improper installation or use of accessories. All parts and accessories added to this vehicle should be genuine Yamaha or equivalent components designed for use on this ATV and should be installed according to the instructions. If

Exhaust system

The exhaust system on the ATV is very hot during and following operation. To prevent burns, avoid touching the exhaust system. Park the ATV in a place where pedestrians or children are not likely to touch it.

⚠ WARNING

POTENTIAL HAZARD

Hot exhaust system.

WHAT CAN HAPPEN

Dry grass or brush or other combustible material accumulated around the engine area could catch fire.

Someone touching the exhaust system during or after operation could be burned.

HOW TO AVOID THE HAZARD

Park the ATV in

**Do not touch the hot exhaust system.
Do not park the ATV in a place where
others might be likely to touch it.**

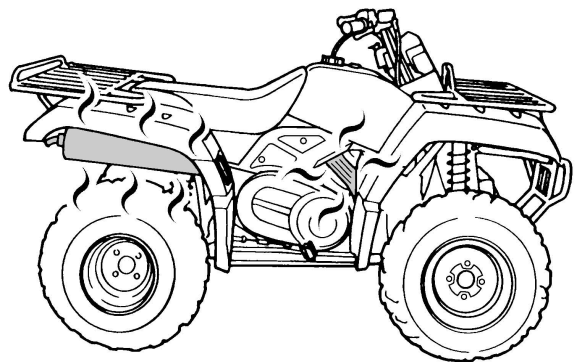

BE CAREFUL WHERE YOU RIDE

This ATV is designed for off-road use only. Riding on paved surfaces can cause loss of control.

⚠ WARNING

POTENTIAL HAZARD

Operating this ATV on paved surfaces.

WHAT CAN HAPPEN

ATVs are designed for off-road use only. Paved surfaces may seriously affect handling and control of the ATV, and may cause the vehicle to go out of control.

HOW TO AVOID THE HAZARD

Always avoid paved surfaces, including sidewalks, driveways, parking lots and streets.

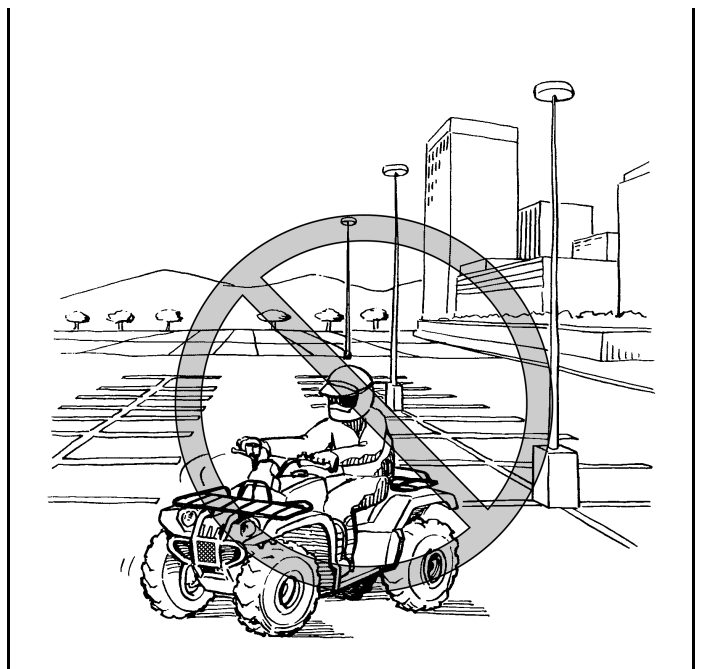

Do not ride on any public road, street, or highway.

Riding on public roads can result in collisions with other vehicles.

⚠ WARNING

POTENTIAL HAZARD

Operating this ATV on public streets, roads or highways.

WHAT CAN HAPPEN

You can collide with another vehicle.

HOW TO AVOID THE HAZARD

Never operate this ATV on any public street, road or highway, even a dirt or gravel one. In many states it is illegal to operate ATVs on public streets, roads and highways.



Know the terrain where you ride. Ride cautiously in unfamiliar areas. Stay alert for **holes, rocks, or roots** in the terrain, and **other hidden hazards** which may cause the ATV to upset.

⚠ WARNING

POTENTIAL HAZARD

Failure to use extra care when operating this ATV on unfamiliar terrain.

WHAT CAN HAPPEN

You can come upon hidden rocks, bumps, or holes, without enough time to react. Could result in the ATV overturning or going out of control.

HOW TO AVOID THE HAZARD

Go slowly and be extra careful when operating on unfamiliar terrain. Always be conditions

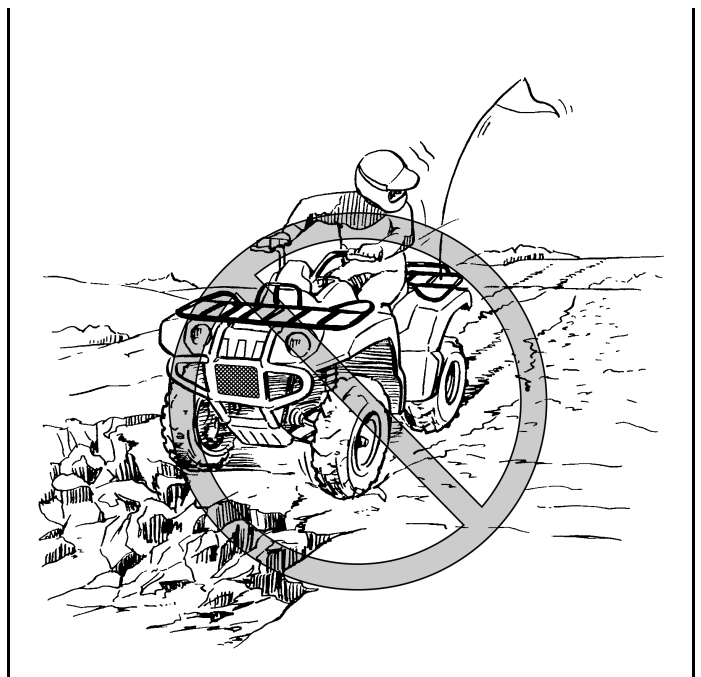

⚠ WARNING

POTENTIAL HAZARD

Failure to use extra care when operating on excessively rough, slippery or loose terrain.

WHAT CAN HAPPEN

Could cause loss of traction or vehicle control, which could result in an accident, including an overturn.

HOW TO AVOID THE HAZARD

Do not operate on excessively rough, slippery or loose terrain until you have learned and practiced the skills necessary to control the ATV on such terrain. Always be especially cautious on these kinds of terrain.



When riding in an area where you might not easily be seen, such as desert terrain, mount a caution flag on the ATV. **DO NOT** use the flag pole bracket as a trailer hitch.

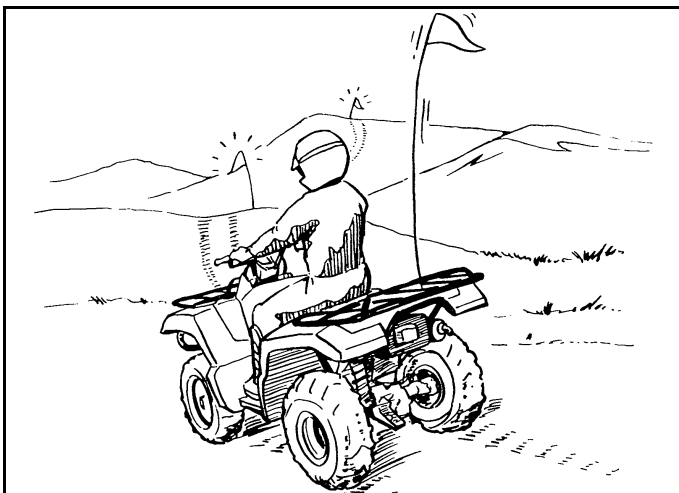

⚠ WARNING

POTENTIAL HAZARD

WHAT CAN HAPPEN

You could be in a collision. You could be injured.

HOW TO AVOID THE HAZARD

Always mount a caution flag on the ATV to make you more visible. Watch carefully for other vehicles.

Do not ride in areas posted “no trespassing”. Do not ride on private property without getting permission.

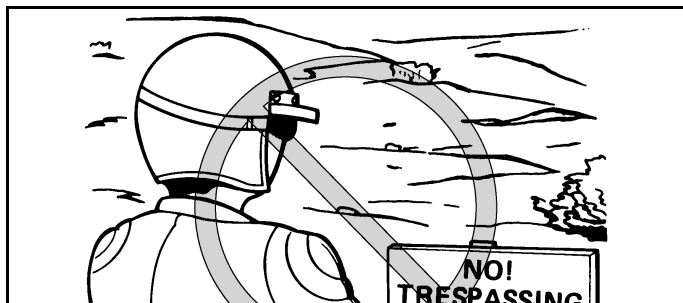

Select a large, flat area off-road to become familiar with your ATV. Make sure that this area is free of obstacles and other riders. You should practice control of the throttle, brakes, and turning techniques in this area before trying more difficult terrain.

Always avoid riding on paved surfaces: the ATV is designed for off-road use only, and handling maneuvers are more difficult to perform on pavement.

Set the parking brake and follow the instruction on page 6-1 to start the engine. Once it has warmed up you are ready to begin riding your ATV. Remember that the engine and exhaust pipe will be hot when riding and afterwards; do not allow skin or clothing to come in contact with these components.

With the engine idling, return the starter (choke) to the closed position, shift the drive select lever into the forward position, and then release the parking brake. Apply the throttle slowly and smoothly. The centrifugal clutch will engage and you will start to accelerate. If the throttle is applied too abruptly, the front wheels may lift off the ground resulting in a loss of directional control. Avoid higher speeds until you are thoroughly familiar with the operation of your ATV.

When slowing down or stopping, release the throttle and apply the brakes smoothly and evenly. Improper use of the brakes can cause the tires to lose traction, reducing control and increasing the possibility of an accident.

TURNING YOUR ATV

To achieve maximum traction while riding off-road, the two rear wheels are mounted solidly on one axle and turn together at the same speed. Therefore, unless the wheel on the inside of the turn is allowed to slip or lose some traction, the ATV will resist turning. A special turning technique must be used to allow the ATV to make turns quickly and easily. It is essential that this skill be learned first at low speed.

WARNING

POTENTIAL HAZARD

Turning improperly.

WHAT CAN HAPPEN

ATV could go out of control, causing a collision or overturn.

HOW TO AVOID THE HAZARD

Always follow proper procedures for turning as described in this Owner's Manual.

Practice turning at low speeds before attempting to turn at faster speeds. Do not turn at speeds too fast for your skills or the conditions.

As you approach a curve, slow down and begin to turn the handlebars in the desired direction. As you do so, put your weight on the footboard to the outside of the turn (opposite your desired direction) and lean your upper body into the turn. Use the throttle to maintain an even speed through the turn. This maneuver will let the wheel on the inside of the turn slip slightly, allowing the ATV to make the turn

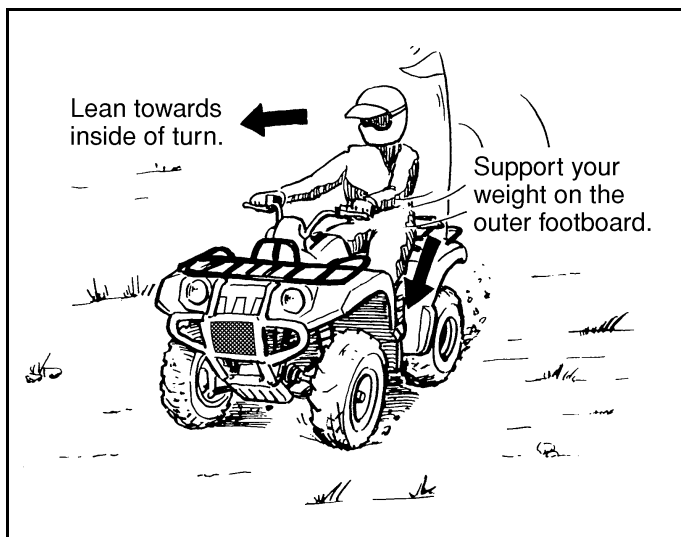

This procedure should be practiced at slow speed many times in a large off-road area with no obstacles. If an incorrect technique is used, your ATV may continue to go straight. If the ATV doesn't turn, come to a stop and then

If the riding cur

Once you have learned this technique you should be able to perform it at higher speeds or in tighter curves.

Improper riding procedures such as abrupt throttle changes, excessive braking, incorrect body movements, or too much speed for the sharpness of the turn may cause the ATV to tip. If the ATV begins to tip over to the outside while negotiating a turn, lean more to the inside. It may also be necessary to gradually let off on the throttle and steer to the outside of the turn to avoid tipping over.

Remember: Avoid higher speeds until you are thoroughly familiar with the operation of your ATV.

CLIMBING UPHILL

Use proper riding techniques to avoid vehicle overturns on hills. Be sure that you can maneuver your ATV well on flat ground before attempting any incline and then practice riding first on gentle slopes. Try more difficult climbs only after you have developed your skill. In all cases avoid inclines with slippery or loose surfaces, or obstacles that might cause you to lose control.

WARNING

POTENTIAL HAZARD

Operating on excessively steep hills.

WHAT CAN HAPPEN

The vehicle can overturn more easily on extremely steep hills than on level surfaces or small hills.

HOW TO AVOID THE HAZARD

Never operate the ATV on hills too steep for the ATV or for your abilities. Practice on smaller hills before attempting large hills.

It is important when climbing a hill to make sure that your weight is transferred forward on the ATV. This can be accomplished by leaning forward and, on steeper inclines, standing on the footboards and leaning forward over the handlebars.

⚠ WARNING

POTENTIAL HAZARD

Climbing hills improperly.

WHAT CAN HAPPEN

Could cause loss of control or cause the ATV to overturn.

HOW TO AVOID THE HAZARD

Always follow proper procedures for climbing hills as described in this Owner's Manual.

Always check the terrain carefully before you start up any hill.

Never climb hills with excessively slippery or loose surfaces.

Shift your weight forward.

Never open the throttle suddenly.

The ATV could flip over backwards.

ny hill at high

An obstacle, a sharp drop, or another vehicle or person could be on the other side of the hill.

OK

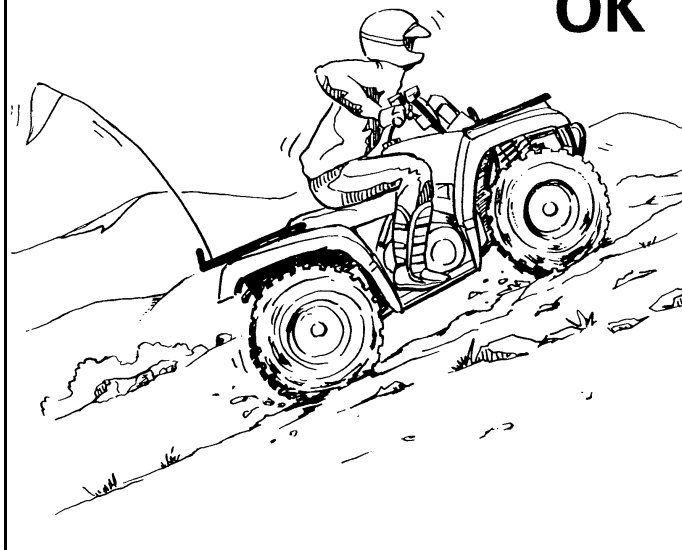

If you are climbing a hill and you find that you have not properly judged your ability to make it to the top, you should turn the ATV around while you still have forward motion (provided you have the room to do so) and go down the hill.

⚠ WARNING

POTENTIAL HAZARD

Improperly crossing hills or turning on hills.

WHAT CAN HAPPEN

Could cause loss of control or cause the ATV to overturn.

HOW TO AVOID THE HAZARD

Never attempt to turn the ATV around on any hill until you have mastered the turning technique as described in the Owner's Manual on level ground. Be very careful when turning on any hill. Avoid crossing the side of a steep hill if possible.

When crossing the side of a hill:

Always follow proper procedures as described in the Owner's Manual.

Avoid hills with excessively slippery or loose surfaces.

Shift your weight to the uphill side of the ATV.

OK

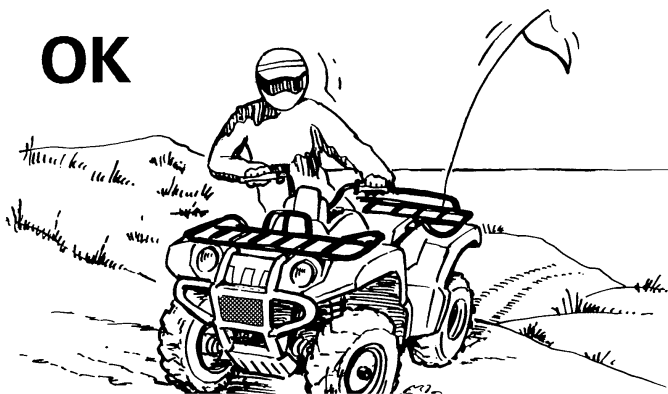

If your ATV has stalled or stopped and you believe you can continue up the hill, restart carefully to make sure you do not lift the front wheels which could cause you to lose control. If you are unable to continue up the hill, dismount the ATV on the uphill side. Physically turn the ATV around and then descend the hill.

If you start to roll backwards, DO NOT apply either brake abruptly. If you are in 2WD, apply only the front brake. When this ATV is in 4WD, all wheels (front and rear) are interconnected by the drive train. This means that applying either the front brake or the rear brake will brake all wheels. When descending hills, using either brake lever or the brake pedal will brake the wheels on the downhill side. Avoid

and rear brakes gradually, or dismount the ATV immediately on the uphill side.

 **WARNING**

POTENTIAL HAZARD

Stalling, rolling backwards or improperly dismounting while climbing a hill.

WHAT CAN HAPPEN

Could result in ATV overturning.

HOW TO AVOID THE HAZARD

Maintain steady speed when climbing a hill.

If you lose all forward speed:

Keep weight uphill.

Apply the brakes.

Apply the parking brake after you are stopped.

If you begin rolling backwards:

Keep weight uphill.

2WD: Never apply the rear brake while rolling backwards. Apply the front brake. When fully stopped, apply the rear brake as well, and then lock the parking brake.

4WD: Apply both front and rear brakes gradually. When fully stopped, lock the parking brake.

Dismount on uphill side or to a side if pointed straight uphill. Turn the ATV around and remount, following the procedure described in the Owner's Manual.

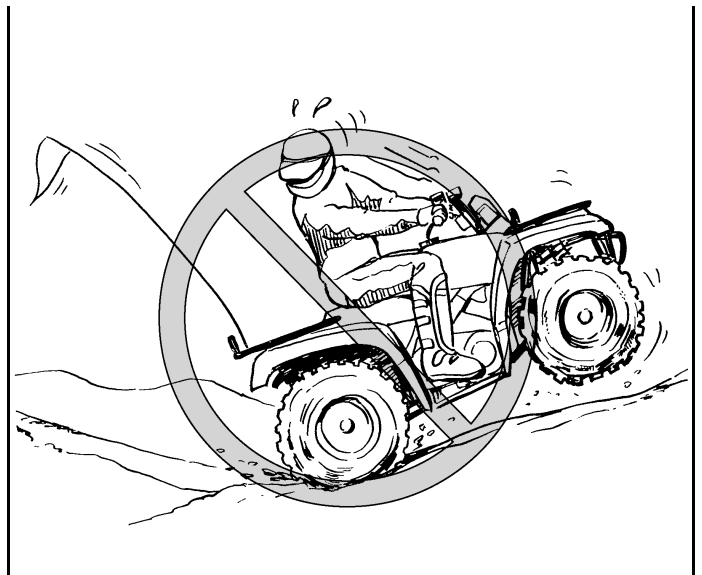

RIDING DOWNHILL

When riding your ATV downhill, shift your weight as far to the rear and uphill side of the ATV as possible. Move back on the seat and sit with your arms straight. Engine compression will do most of the braking for you. For maximum engine compression braking effect, change to 4WD before beginning to descend the hill. Improper braking may cause a loss of traction. Use caution while descending a hill with loose or slippery surfaces. Braking ability and traction may be adversely affected by these surfaces. Improper braking may also cause a loss of traction.

When this ATV is in 4WD, all wheels (front and rear) are interconnected by the drive train. This means that applying either the front brake or the rear brake will brake all wheels. When descending hills, using either brake lever or the brake pedal will brake the wheels on the downhill side. Avoid sudden application of either the front or rear brake because the wheels on the uphill side could come off the ground. Apply both the front and rear brakes gradually.

Whenever possible, ride your ATV straight downhill. Avoid sharp angles which could allow the ATV to tip or roll over. Carefully choose your path and ride no faster than you will be able to react to obstacles which may appear.

⚠ WARNING

POTENTIAL HAZARD

Going down a hill improperly.

WHAT CAN HAPPEN

Could cause loss of control or cause the ATV to overturn.

Always follow proper procedures for going down hills as described in this Owner's Manual. Note: a special technique is required when braking as you go down a hill.

HOW TO AVOID THE HAZARD

Always check the terrain carefully before you start down any hill.

Shift your weight backward.

Never go down a hill at high speed.

Avoid going down a hill at an angle that lean sharply

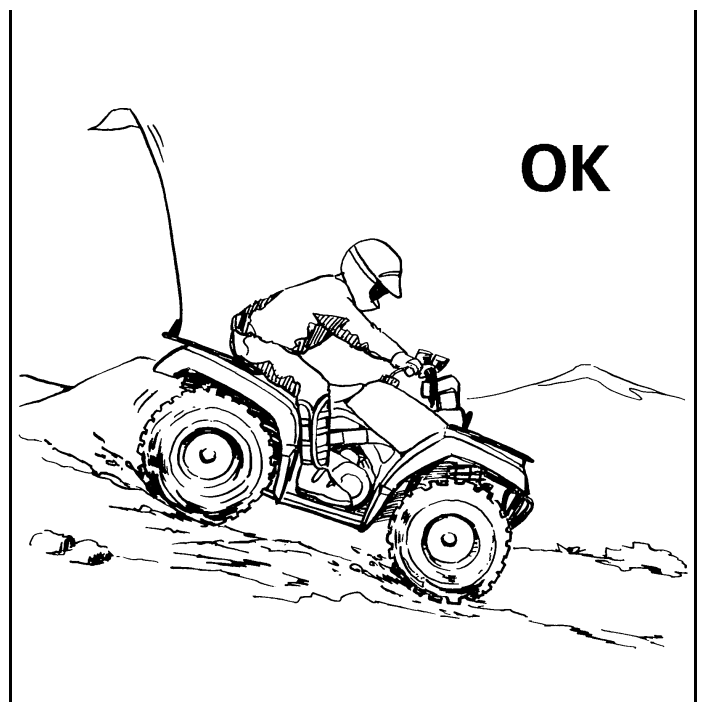

CROSSING A SLOPE

Traversing a sloping surface on your ATV requires you to properly position your weight to maintain proper balance. Be sure that you have learned the basic riding skills on flat ground before attempting to cross a sloping surface. Avoid slopes with slippery surfaces or rough terrain that may upset your balance.

As you travel across a slope, lean your body in the uphill direction. It may be necessary to correct the steering when riding on loose surfaces by pointing the front wheels slightly uphill. When riding on slopes be sure not to make sharp turns either up or down hill.

If your ATV does begin to tip over, gradually steer in the downhill direction if there are no
regain proper

⚠ WARNING

POTENTIAL HAZARD

Improperly crossing hills or turning on hills.

WHAT CAN HAPPEN

Could cause loss of control or cause the ATV to overturn.

HOW TO AVOID THE HAZARD

Never attempt to turn the ATV around on any hill until you have mastered the turning technique as described in the Owner's Manual on level ground. Be very careful when turning on any hill. Avoid crossing the side of a steep hill if possible.

When crossing the side of a hill:

Always follow proper procedures as described in the Owner's Manual



CROSSING THROUGH SHALLOW WATER

The ATV can be used to cross slow moving, shallow water of up to a maximum of 35 cm (14 inches) in depth. Before entering the water, choose your path carefully. Enter where there is no sharp drop off, and avoid rocks or other obstacles which may be slippery or upset the ATV. Drive slowly and carefully.

⚠ WARNING

POTENTIAL HAZARD

Operating this ATV through deep or fast flowing water.

WHAT CAN HAPPEN

Tires may float, causing loss of traction and loss of control, which could lead to an accident.

HOW TO AVOID THE HAZARD

fast flowing

Remember that wet brakes may have reduced stopping ability. Test your brakes after leaving water. If necessary, apply them several times to let friction dry out the linings.

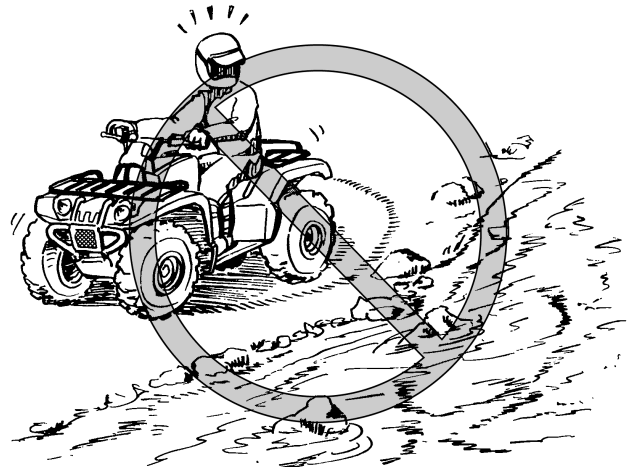

Test your brakes after leaving the water. Do not continue to ride your ATV without verifying that you have regained proper braking ability.

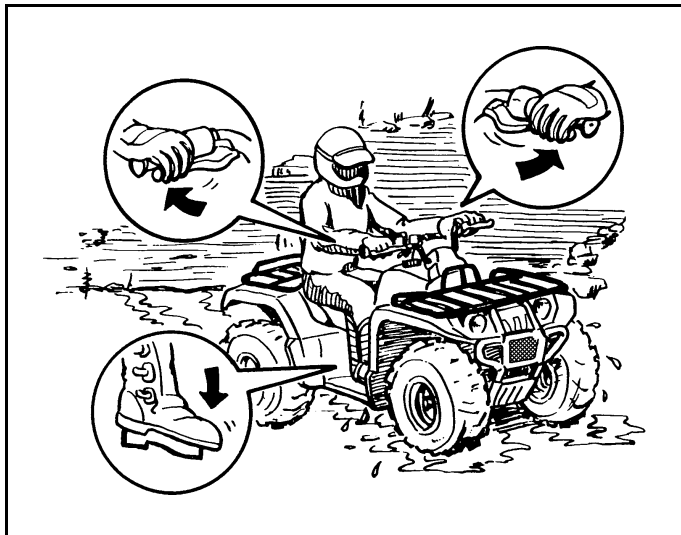

CAUTION:

After riding your ATV in water, be sure to drain the trapped water by removing the check hose at the bottom of the air filter case, the V-belt cooling duct check hose, the drive select lever box check hose and the storage box check hose. Also, remove the V-belt case drain plug to drain any water that may have accumulated. Wash the ATV in fresh water if it has been operated in salt water or muddy conditions.

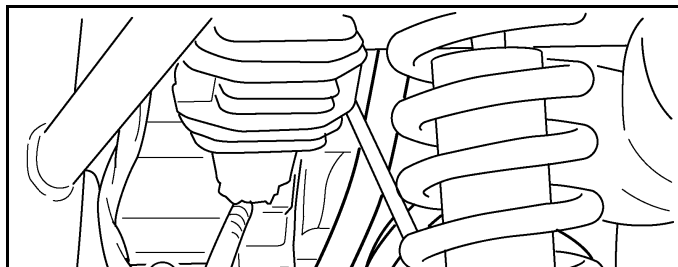

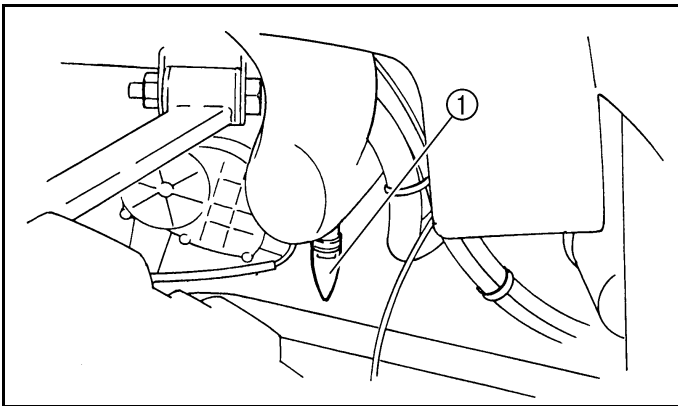

1. V-belt cooling duct check hose (left front side of ATV)

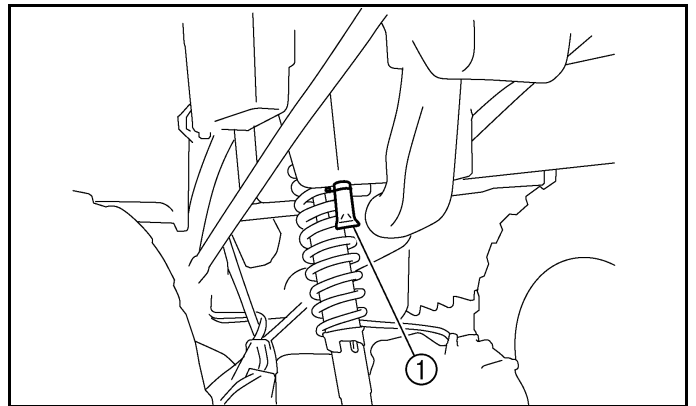

1. Storage box check hose

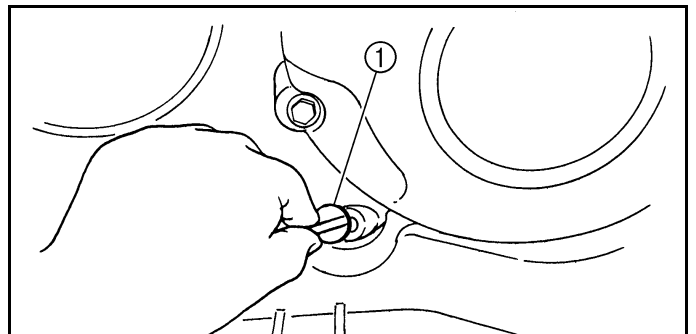
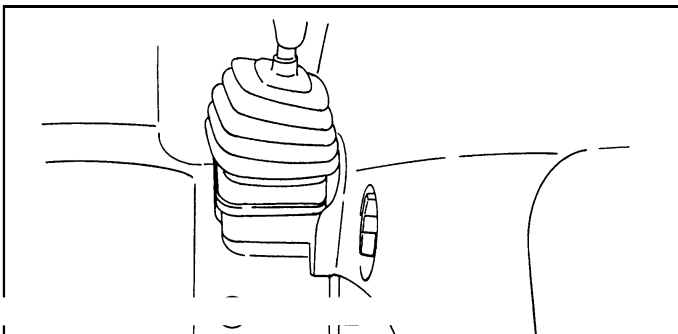

RIDING OVER ROUGH TERRAIN

Riding over rough terrain should be done with caution. Look out for obstacles which could cause damage to the ATV or could lead to an upset or accident. Be sure to keep your feet firmly mounted on the footboards at all times. Avoid jumping the ATV as loss of control and damage to the ATV may result.

WARNING

POTENTIAL HAZARD

Improperly operating over obstacles.

WHAT CAN HAPPEN

Could cause loss of control or a collision. Could cause the ATV to overturn.

HOW TO AVOID THE HAZARD

Before operating in a new area, check for obstacles.

Never attempt to ride over large obstacles, such as large rocks or fallen trees.

When you go over obstacles, always follow proper procedures as described in the Owner's Manual.

SLIDING AND SKIDDING

Care should be used when riding on loose or slippery surfaces since the ATV may slide. If unexpected and uncorrected, sliding could lead to an accident.

To reduce the tendency for the front wheels to slide in loose or slippery conditions, positioning your weight over the front wheels will sometimes help.

If the rear wheels of your ATV start to slide sideways, control can usually be regained (if there is room to do so) by steering in the direction of the slide. Applying the brakes or accelerating is not recommended until you have corrected the slide.

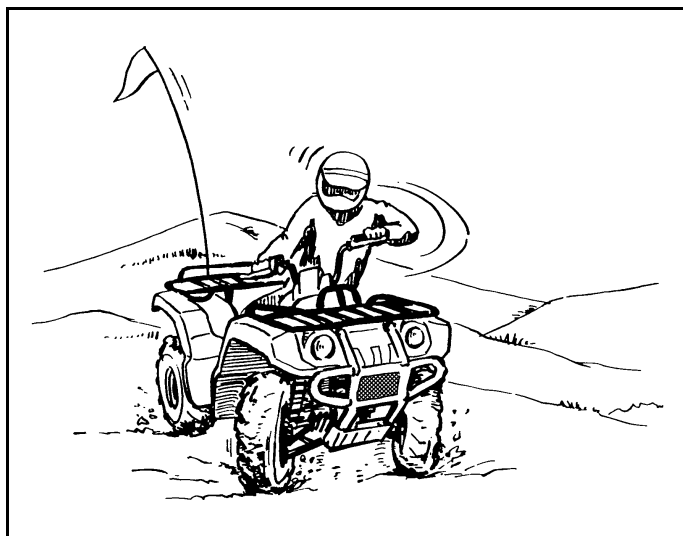
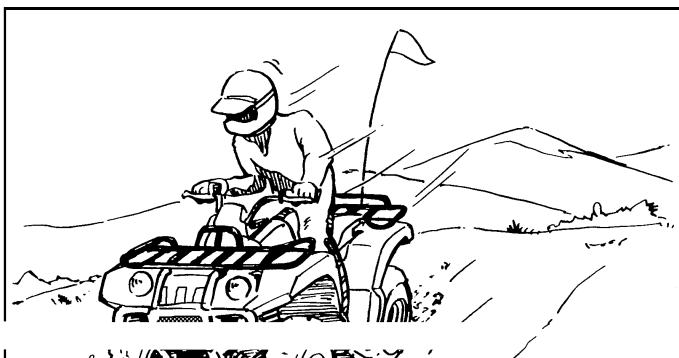

With practice, over a period of time, skill at controlled sliding can be developed. The terrain should be chosen carefully before attempting such maneuvers, since both stability and control are reduced. Bear in mind that sliding maneuvers should always be avoided on extremely slippery surfaces such as ice, since all control may be lost.

 **WARNING**

POTENTIAL HAZARD

Skidding or sliding improperly.

WHAT CAN HAPPEN

You may lose control of this ATV. You may also regain traction unexpectedly, which may cause the ATV to overturn.

HOW TO AVOID THE HAZARD

Learn to safely control skidding or sliding by practicing at low speeds and on level, smooth terrain.

On extremely slippery surfaces, such as ice, go slowly and be very cautious in order to reduce the chance of skidding or sliding out of control.

WHAT TO DO IF ...

This section is designed to be a reference guide only. Be sure to read each section on riding techniques completely.

WHAT TO DO ...

- If your ATV doesn't turn when you want it to:
Bring the ATV to a stop and practice the turning maneuvers again. Be sure you are putting your weight on the footboard to the outside of the turn. Position your weight over the front wheels for better control. (See pages 7-22–7-23.)
- If your ATV begins to tip while turning:
Lean more into the turn to regain balance. If necessary, gradually let off the throttle and/or steer to the outside of the turn. (See pag-

- If your ATV starts to slide sideways:
Steer in the direction of the slide if you have the room. Applying the brakes or accelerating is not recommended until you have corrected the slide. (See pages 7-38–7-39.)
- If your ATV can't make it up a hill you are trying to climb:
Turn the ATV around if you still have forward speed. If not, stop, dismount on the uphill side of the ATV and physically turn the ATV around. If the ATV starts to slip backwards, **DO NOT USE THE REAR BRAKE** - the ATV may tip over on top of you. Dismount the ATV on the uphill side. (See pages 7-24–7-29.)

- If your ATV is traversing a sloping surface:
Be sure to ride with your weight positioned towards the uphill side of the ATV to maintain proper balance. If the ATV starts to tip, steer down the hill (if there are no obstacles in your way) to regain balance. If you discover that the ATV is going to tip over, dismount on the uphill side. (See pages 7-32–7-33.)
- If your ATV encounters shallow water:
Ride slowly and carefully through slow moving water, watching for obstacles. Be sure to let water drain from the ATV and **CHECK YOUR BRAKES FOR PROPER OPERATION** when you come out of the water. Do not continue to ride your ATV until you have regained adequate braking ability. (See pages 7-34–7-36.)

EBU00515

PERIODIC MAINTENANCE AND ADJUSTMENT

Periodic inspection, adjustment and lubrication will keep your machine in the safest and most efficient condition possible. Safety is an obligation of the machine owner. The most important points of machine inspection, adjustment and lubrication are explained on the following pages.

WARNING

POTENTIAL HAZARD

Servicing an engine while it is running.

WHAT CAN HAPPEN

Moving parts can catch clothing or parts of the body, causing injury.

Electrical components can cause

Have a Yamaha dealer perform service if you are not familiar with machine service.

EBU14510

Owner's manual and tool kit

You are recommended to put this owner's manual in the vinyl bag and always carry it on the bottom of the seat as shown. Put the owner's tool kit and low-pressure tire gauge under the seat.

The service information included in this manual is intended to provide you, the owner, with the necessary information for completing your own preventive maintenance and minor repairs. The tools provided in the Owner's tool kit are sufficient for this purpose, except that a torque wrench is also necessary to properly tighten nuts and bolts.

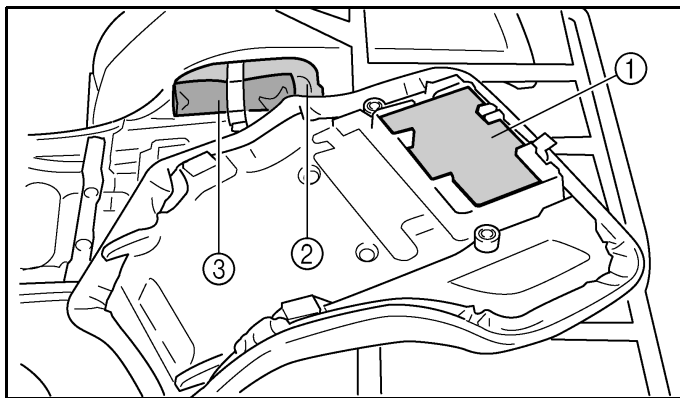

1. Owner's manual
2. Owner's tool kit
3. Low-pressure tire gauge

NOTE:

If you do not have a torque wrench available during a service operation requiring one, take your machine to a Yamaha dealer to check the torque settings and adjust them as necessary.

⚠ WARNING

POTENTIAL HAZARD

Operating this ATV with improper modifications.

WHAT CAN HAPPEN

Improper installation of accessories or modification of this vehicle may cause changes in handling which in some situations could lead to an accident.

HOW TO AVOID THE HAZARD

Never modify this ATV through improper installation or use of accessories. All parts and accessories added to this vehicle should be genuine Yamaha or equivalent components designed for use on this ATV and should be installed and used according to instructions. If you have questions, consult an autho-

EBU00261

PERIODIC MAINTENANCE/LUBRICATION

ITEM	ROUTINE	INITIAL			EVERY	
		1 month	3 months	6 months	6 months	1 year
Valves*	<ul style="list-style-type: none"> • Check valve clearance. • Adjust if necessary. 	<input type="radio"/>		<input type="radio"/>	<input type="radio"/>	<input type="radio"/>
Spark plug	<ul style="list-style-type: none"> • Check condition. • Adjust gap and clean. • Replace if necessary. 	<input type="radio"/>	<input type="radio"/>	<input type="radio"/>	<input type="radio"/>	<input type="radio"/>
Air filter element	<ul style="list-style-type: none"> • Clean. • Replace if necessary. 	Every 20–40 hours (More often in wet or dusty areas.)				
Carburetor*	<ul style="list-style-type: none"> • Check and adjust idle speed/starter operation. • Adjust if necessary. 		<input type="radio"/>	<input type="radio"/>	<input type="radio"/>	<input type="radio"/>
Crankcase breather system*	<ul style="list-style-type: none"> • Check breather hose for cracks or damage. • Replace if necessary. 			<input type="radio"/>	<input type="radio"/>	<input type="radio"/>
Exhaust system*	<ul style="list-style-type: none"> • Check for leakage. • Tighten if necessary. • Replace gasket(s) if necessary. 			<input type="radio"/>	<input type="radio"/>	<input type="radio"/>
Spark arrester	<ul style="list-style-type: none"> • Clean. 			<input type="radio"/>	<input type="radio"/>	<input type="radio"/>
Fuel line*	<ul style="list-style-type: none"> • Check fuel hose for cracks or damage. • Replace if necessary. 			<input type="radio"/>	<input type="radio"/>	<input type="radio"/>
Engine oil	<ul style="list-style-type: none"> • Replace. (Warm engine before draining.) 	<input type="radio"/>		<input type="radio"/>	<input type="radio"/>	<input type="radio"/>
Engine oil filter cartridge	<ul style="list-style-type: none"> • Replace. 	<input type="radio"/>		<input type="radio"/>		<input type="radio"/>
Engine oil strainer*	<ul style="list-style-type: none"> • Clean. 	<input type="radio"/>		<input type="radio"/>		<input type="radio"/>
Final gear oil	<ul style="list-style-type: none"> • Check for oil leakage. 	<input type="radio"/>				<input type="radio"/>
Differential gear oil	<ul style="list-style-type: none"> • Replace every 12 months. 	<input type="radio"/>				<input type="radio"/>
Front brake*	<ul style="list-style-type: none"> • Check operation/fluid leakage. (See NOTE page 8-4.) 	<input type="radio"/>	<input type="radio"/>	<input type="radio"/>	<input type="radio"/>	<input type="radio"/>
Rear brake	<ul style="list-style-type: none"> • Check operation/fluid leakage. (See NOTE page 8-4.) 	<input type="radio"/>	<input type="radio"/>	<input type="radio"/>	<input type="radio"/>	<input type="radio"/>

ITEM	ROUTINE	INITIAL			EVERY	
		1 month	3 months	6 months	6 months	1 year
V-belt*	<ul style="list-style-type: none"> • Check operation. • Check for cracks or damage. 	<input type="radio"/>		<input type="radio"/>	<input type="radio"/>	<input type="radio"/>
Wheels*	<ul style="list-style-type: none"> • Check balance/damage/runout. • Repair if necessary. 	<input type="radio"/>		<input type="radio"/>	<input type="radio"/>	<input type="radio"/>
Wheel bearing*	<ul style="list-style-type: none"> • Check bearing assemblies for looseness/damage. • Replace if damaged. 	<input type="radio"/>		<input type="radio"/>	<input type="radio"/>	<input type="radio"/>
Front and rear suspension*	<ul style="list-style-type: none"> • Check operation. • Correct if necessary. 			<input type="radio"/>		<input type="radio"/>
Steering system*	<ul style="list-style-type: none"> • Check operation./Replace if damaged. • Check toe-in./Adjust if necessary. 	<input type="radio"/>	<input type="radio"/>	<input type="radio"/>	<input type="radio"/>	<input type="radio"/>
Drive shaft universal joint*	<ul style="list-style-type: none"> • Lubricate. 			<input type="radio"/>	<input type="radio"/>	<input type="radio"/>
Axle boots*	<ul style="list-style-type: none"> • Check operation. • Replace if damaged. 	<input type="radio"/>	<input type="radio"/>	<input type="radio"/>	<input type="radio"/>	<input type="radio"/>
Fittings and fasteners*	<ul style="list-style-type: none"> • Check all chassis fittings and fasteners. • Correct if necessary. 	<input type="radio"/>	<input type="radio"/>	<input type="radio"/>	<input type="radio"/>	<input type="radio"/>
Lights and switches*	<ul style="list-style-type: none"> • Check operation. • Adjust headlight beams. 	<input type="radio"/>	<input type="radio"/>	<input type="radio"/>	<input type="radio"/>	<input type="radio"/>

* Since these items require special tools, data and technical skills, have a Yamaha dealer perform the service.

NOTE: _____

- Recommended brake fluid: DOT 4
- Brake fluid replacement:
 - When disassembling the master cylinder or calibrally check the

EBU08070

Panel removal and installation

The panel illustrated needs to be removed to perform some of the maintenance described in this chapter.

Refer to this section each time the panel has to be removed or installed.

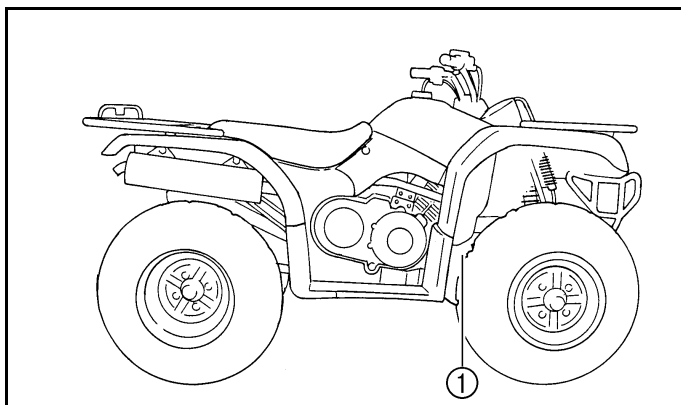

1. Panel A

EBU01147

Panel A

To remove

Remove the bolt, and then take the panel off.

To install

Place the panel in the original position and install the bolt.

CAUTION:

When installing the panel, be sure not to pinch the cables or wires.

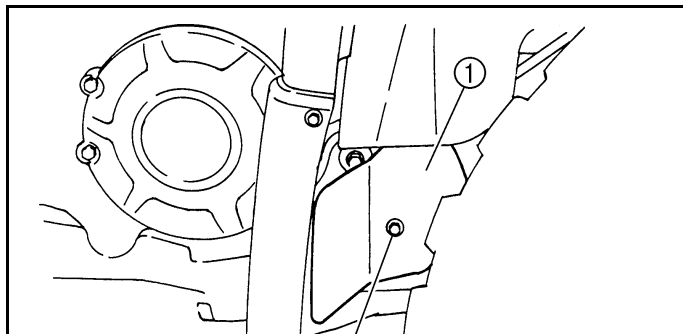

EBU14540

Engine oil and oil filter cartridge

The engine oil level should be checked before each ride. In addition, the oil must be changed and the oil filter cartridge replaced at the intervals specified in the periodic maintenance and lubrication chart.

To check the engine oil level

1. Place the ATV on a level surface.
2. Start the engine, warm it up for several minutes, and then turn it off.
3. Wait a few minutes until the oil settles.

4. Remove the engine oil filler cap and wipe off the dipstick with a clean rag.

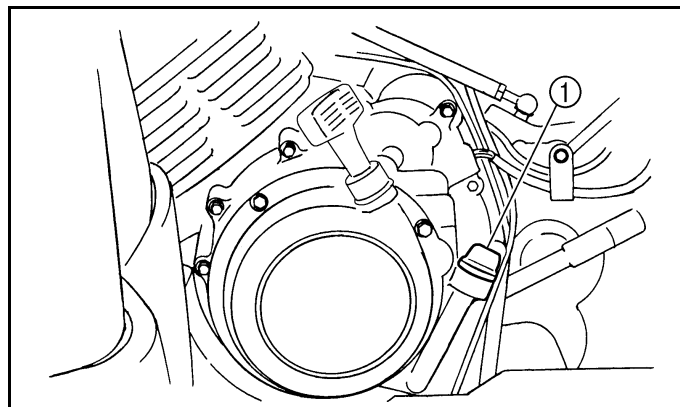

1. Engine oil filler cap

5. Insert the dipstick in the oil filler hole (without screwing it in), and then remove it again to check the oil level.

NOTE: _____
The engine oil should be between the minimum and maximum level marks.

7. Insert the dipstick into the oil filler hole, and then tighten the oil filler cap.

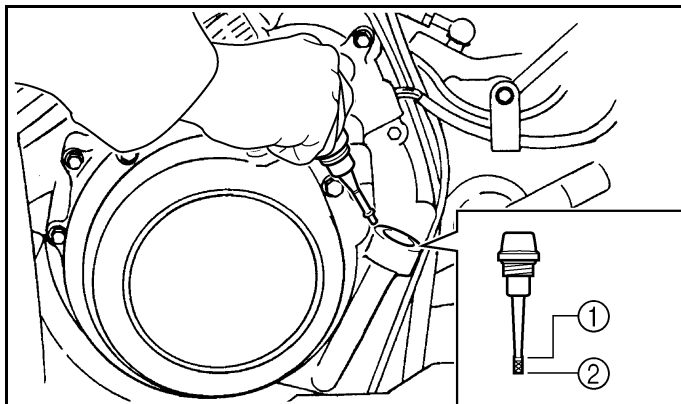

1. Maximum level mark

2. Minimum level mark

elow the mini-

To change the engine oil (with or without oil filter cartridge replacement)

1. Start the engine, warm it up for several minutes, and then turn it off.
2. Place an oil pan under the engine to collect the used oil, and then remove the engine oil filler cap.
3. Remove the engine oil drain bolt to drain the oil from the crankcase.

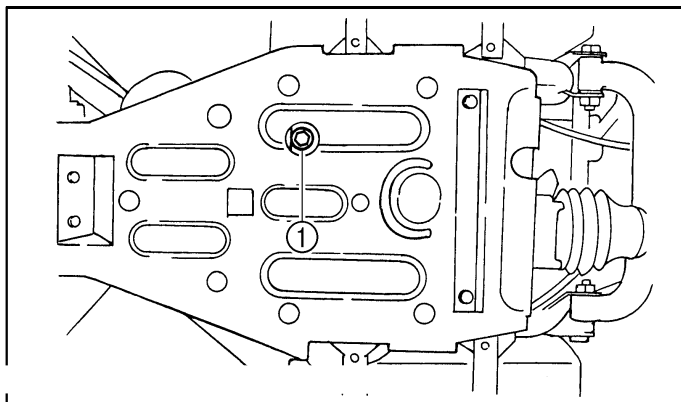

NOTE: Skip steps 4–6 if the oil filter cartridge is not being replaced.

4. Remove the oil filter cartridge with an oil filter wrench.

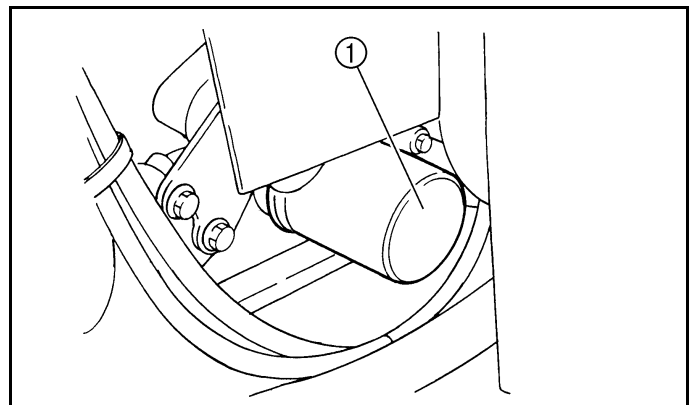

1. Oil filter cartridge

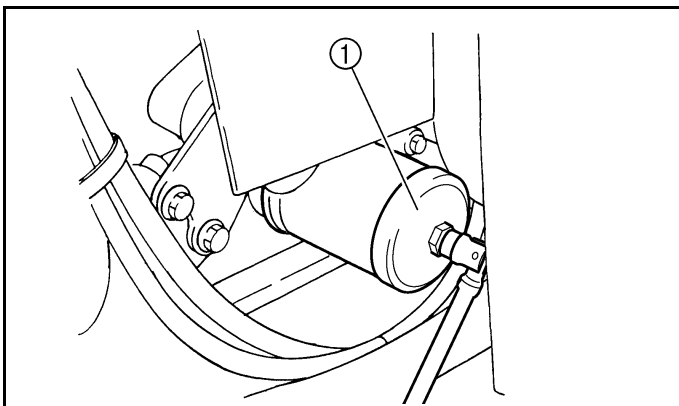

1. Oil filter wrench

NOTE: _____
An oil filter wrench is available at a nearby Yamaha dealer.

5. Apply a light coat of engine oil to the O-ring of the new oil filter cartridge.

NOTE: _____
_____ properly.

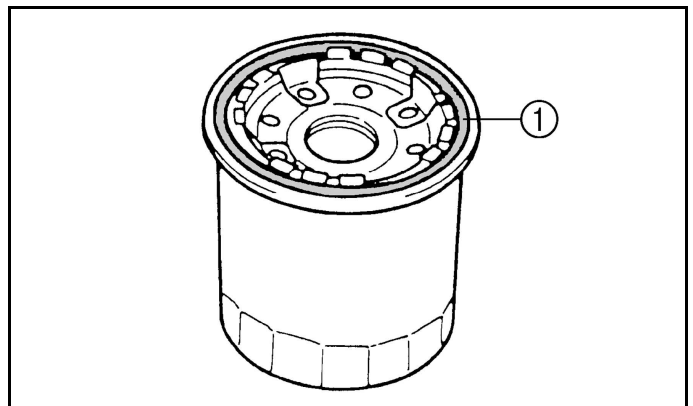

1. O-ring

6. Install the new oil filter cartridge with an oil filter wrench, and then tighten it to the specified torque with a torque wrench.

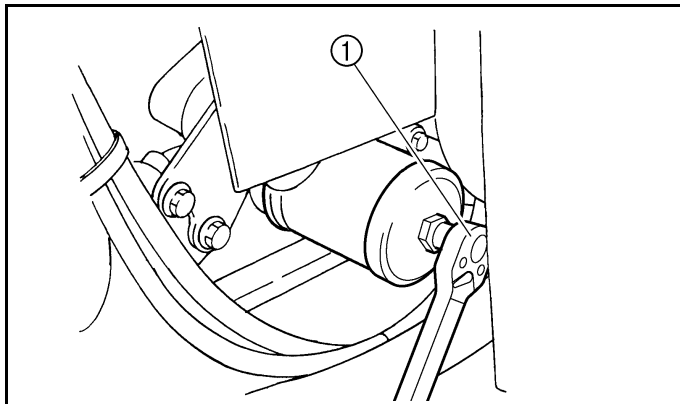

1. Torque wrench

Tightening torque:
Oil filter cartridge:
17 Nm (1.7 m·kgf, 12 ft·lbf)

7. Install the engine oil drain bolt, and then tighten it to the specified torque.

Tightening torque:
Engine oil drain bolt:
23 Nm (2.3 m·kgf, 16 ft·lbf)

8. Add the specified amount of recommended engine oil, and then install the engine oil filler cap and tighten it.

Recommended engine oil:
See page 10-2.
Oil quantity:
Without oil filter cartridge replacement:
2.2 L (1.94 Imp qt, 2.33 US qt)
With oil filter cartridge replacement:
2.3 L (2.02 Imp qt, 2.43 US qt)

CAUTION:

- In order to prevent clutch slippage (since the engine oil also lubricates the clutch), do not mix any chemical additives. Do not use oils with a diesel specification of “CD” or oils of a higher quality than specified. In addition, do not use oils labeled “ENERGY CONSERVING II” or higher.
- Make sure that no foreign material enters the crankcase.

9. Start the engine and warm it up for several minutes. While warming up, check for oil leakage. If oil leakage is found, turn the engine off immediately and check for the cause.

hen check the

EBU11452

Final gear oil

Final gear oil measurement

1. Place the machine on a level surface.
2. Remove the oil filler bolt, and then check the oil level in the final gear case.

NOTE:

The oil level should be at the brim of the filler hole.

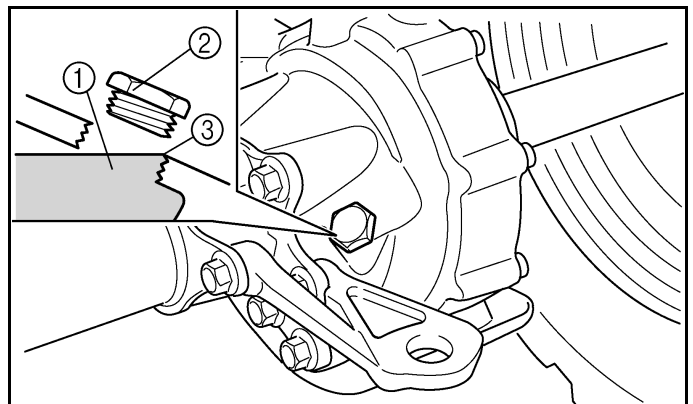

3. If the oil is below the brim of the filler hole, add sufficient oil of the recommended type to raise it to the correct level.

CAUTION:

Be sure no foreign material enters the final gear case.

4. Install the oil filler bolt.

Final gear oil replacement

1. Remove the final gear case cover by removing the bolts.

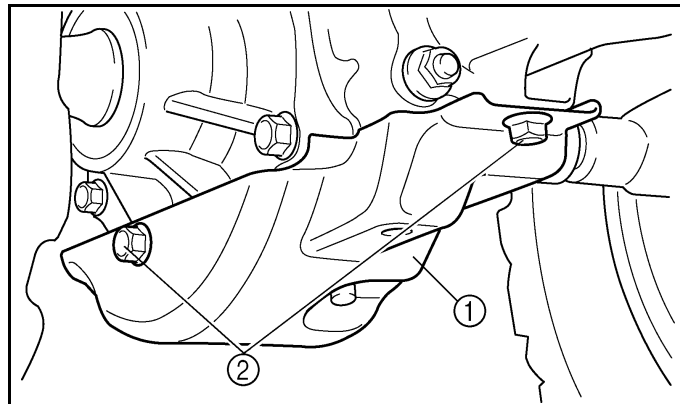

1. Final gear case cover 2. Bolt (× 2)

2. Place the machine on a level surface.
3. Place a container under the final gear case to collect the used oil.

4. Remove the oil filler bolt and the drain bolt to drain the oil.

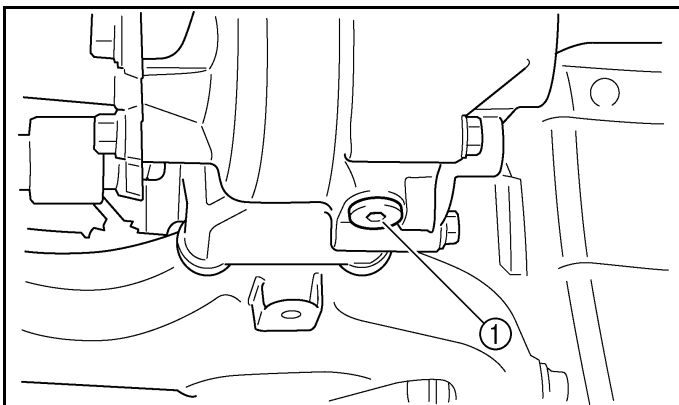

1. Final gear oil drain bolt

5. Install the drain bolt, and then tighten it to the specified torque.

Tightening torque:
Final gear oil drain bolt:

bf)

Recommended oil:
SAE 80 API GL-4 Hypoid gear oil
Oil quantity:
0.23 L (0.20 Imp qt, 0.24 US qt)

CAUTION:

Be sure no foreign material enters the final gear case.

7. Install the oil filler bolt.
8. Check for oil leakage. If oil leakage is found, check for the cause.
9. Install the final gear case cover bolts, and then tighten them to the specified torque.

Tightening torque:
Final gear case cover bolt:
16 Nm (1.6 m·kgf, 11 ft·lbf)

EBU01241

Differential gear oil replacement

1. Place the machine on a level surface.
2. Place a container under the differential gear case to catch the oil.
3. Remove the oil filler bolt and oil drain bolt to drain the oil.

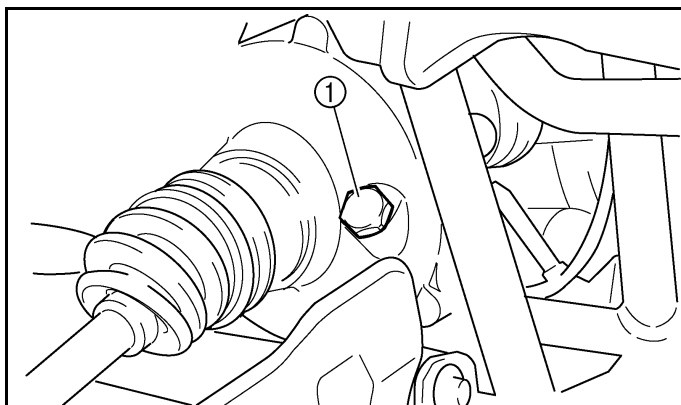

1. Differential gear oil filler bolt

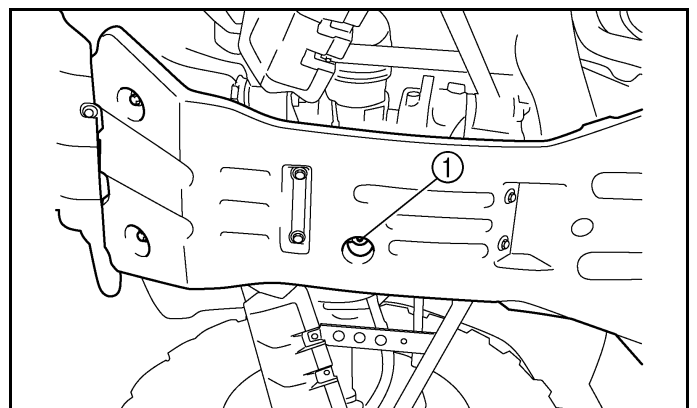

1. Differential gear oil drain bolt

4. Install the oil drain bolt, and then tighten it to the specified torque.

Tightening torque:

Drain bolt:

10 Nm (1.0 m·kgf, 7 ft·lbf)

5. Fill the differential gear case with the specified amount of the recommended oil.

NOTE:

- Do not exceed the specified differential gear oil quantity when filling. Overfilling will cause the oil to seep out of the breather hose during and after riding.
- The differential gear oil level cannot be checked. The differential gear case capacity is greater than the recommended oil quantity, therefore the oil level cannot be accurately checked from the oil filler cap hole.

CAUTION:

Be sure no foreign material enters the differential gear case.

6. Install the oil filler bolt.
7. Check for oil leakage. If oil leakage is found, check for the cause.

Recommended oil:
SAE 80 API "GL-4" Hypoid gear oil

EBU00862

Axle boots

Check the protective boots for holes or tears. If any damage is found, have them replaced by a Yamaha dealer.

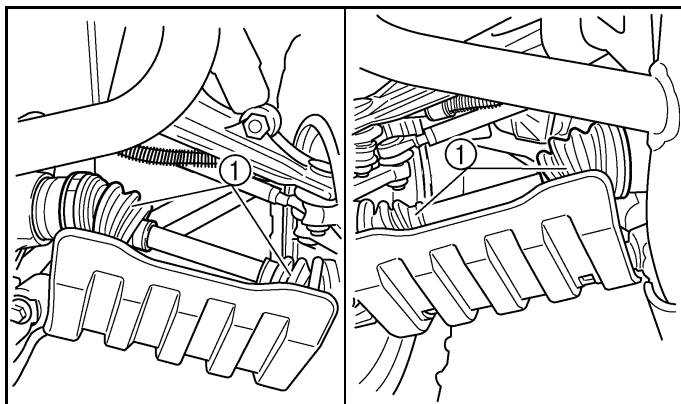

1. Axle boot (× 2 each side)

EBU14550

Spark plug inspection

Removal

1. Remove the spark plug cap.

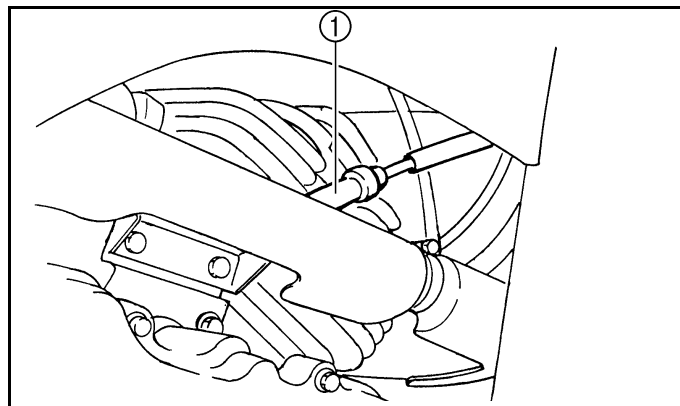

1. Spark plug cap

2. Use the spark plug wrench in the owner's tool kit to remove the spark plug as shown.

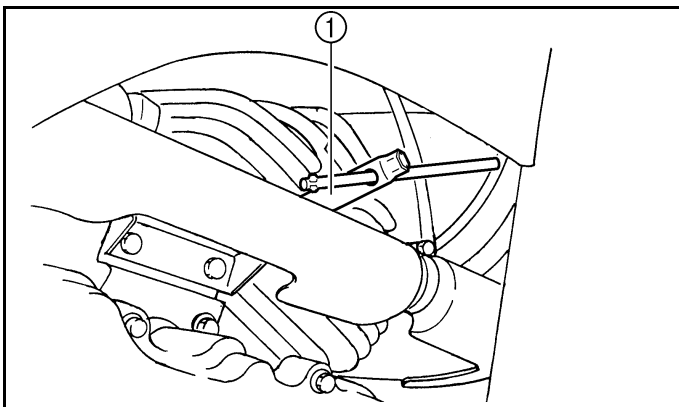

1. Spark plug wrench

Inspection

The spark plug is an important engine component and is easy to inspect. The condition of the spark plug can indicate the condition of the engine.

Instead, take the ATV to a Yamaha dealer. You should periodically remove and inspect the spark plug because heat and deposits will cause the spark plug to slowly break down and erode. If electrode erosion becomes excessive, or if carbon and other deposits are excessive, you should replace the spark plug with the specified plug.

Specified spark plug:
DR8EA (NGK)

Installation

1. Measure the electrode gap with a wire thickness gauge and, if necessary, adjust the gap to specification.

Spark plug gap:
0.6–0.7 mm (0.02–0.03 in)

insulator around

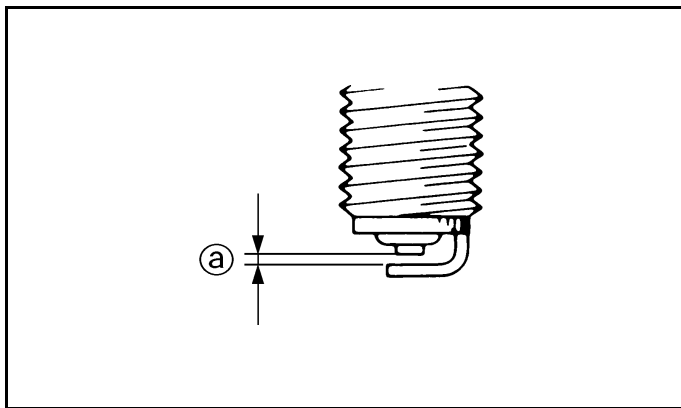

a. Spark plug gap

2. Clean the surface of the spark plug gasket and its mating surface, and then wipe off any grime from the spark plug threads.
3. Install the spark plug and tighten it to the specified torque.

NOTE: _____
If a torque wrench is not available when you are installing a spark plug, a good estimate of the correct torque is 1/4 to 1/2 turn past finger tight. Have the spark plug tightened to the specified torque as soon as possible.

4. Install the spark plug cap.

EBU11332

Air filter element cleaning

NOTE:

There is a check hose at the bottom of the air filter case. If dust or water collects in this hose, empty the hose and clean the air filter element and air filter case.

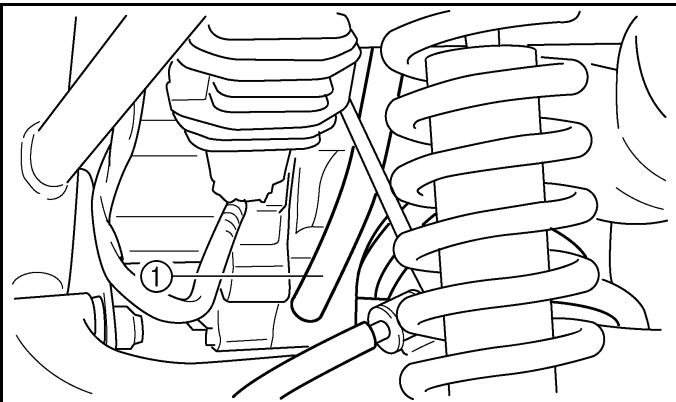

1. Air filter case check hose

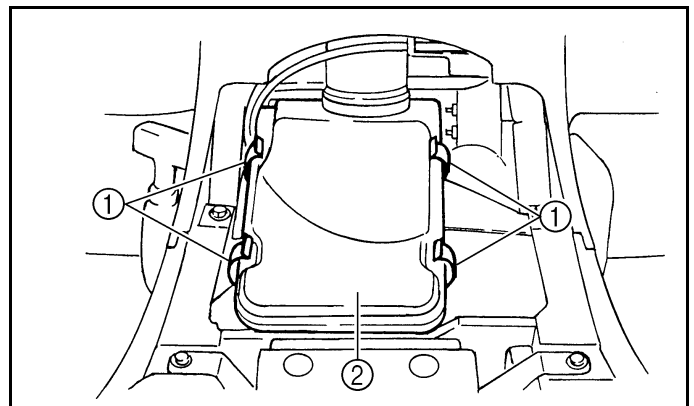

1. Holder (× 4)

2. Air filter case cover

3. Remove the air filter element assembly, and then remove the air filter element from its frame.

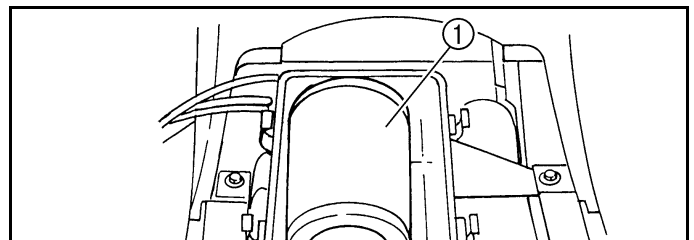

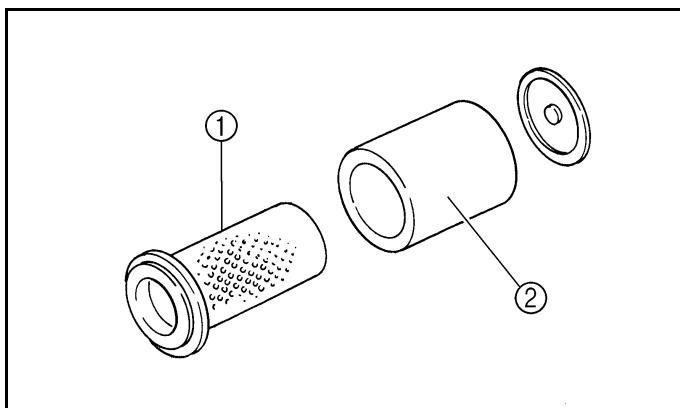

1. Air filter element frame 2. Air filter element
4. Wash the element gently but thoroughly in solvent.

⚠ WARNING

POTENTIAL HAZARD

Using low flash point solvents or gasoline to clean the air filter element.

WHAT CAN HAPPEN

Low flash point solvents or gasoline can catch fire or explode.

HOW TO AVOID THE HAZARD

Use parts cleaning solvent to clean the air filter element.

5. Squeeze the excess solvent out of the air filter element and let it dry.

CAUTION: _____

Do not twist the air filter element when squeezing it.

6. Inspect the air filter element and replace

7. Apply Yamaha foam air filter oil or other quality foam air filter oil to the air filter element. If foam air filter oil is not available, engine oil may be used.

NOTE: _____
The air filter element should be wet but not dripping.

8. Pull the air filter element over its frame.
9. Install the air filter element assembly.
10. Install the air filter case cover by hooking the holders.
11. Install the seat.

NOTE: _____
The air filter element should be cleaned every 20–40 hours. It should be cleaned and lubricated more often if the machine is operated in extremely dusty areas. Each time the air filter element maintenance is performed, check the air inlet to the filter case for obstructions. Check the air filter case rubber joint to the carburetor and manifold fittings for an airtight seal. Tighten all fittings securely to avoid the possibility of unfiltered air entering the engine.

CAUTION: _____
Never operate the engine with the air filter element removed. This will allow unfiltered air to enter, causing rapid engine wear and possible engine damage. Additionally, operation without the air filter element will affect carburetor jetting with subsequent

EBU06411

V-belt cooling duct check hose

If dust or water collects in the V-belt cooling duct check hose, remove the hose and clean it.

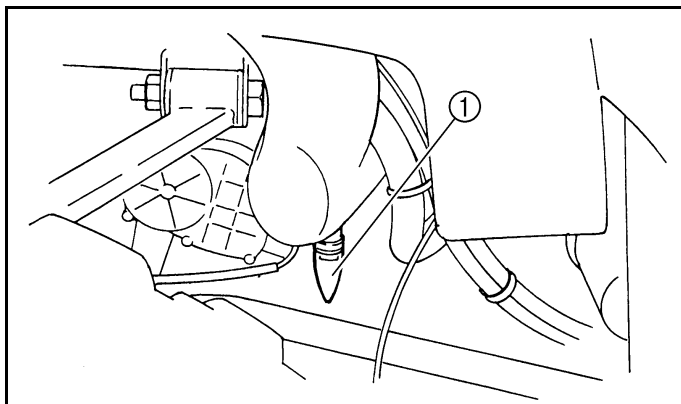

1. V-belt cooling duct check hose (Left front side of ATV)

EBU08741

V-belt case drain plug

After riding in water deep enough to allow it to enter the V-belt case, remove this plug to drain the water from the case.

NOTE: _____
If water drains from the V-belt case after removing the plug, have a Yamaha dealer inspect the ATV as the water may affect other engine parts.

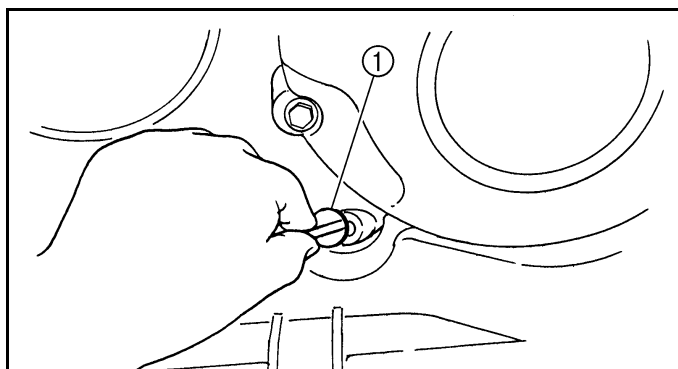

EBU01066

Spark arrester cleaning

Be sure the exhaust pipe and muffler are cool before cleaning the spark arrester.

1. Remove the bolts.
2. Remove the tailpipe by pulling it out of the muffler.

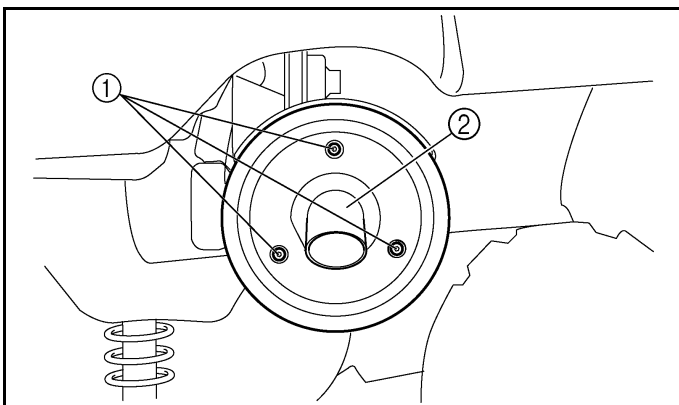

1. Bolt (× 3)

2. Tailpipe

3. Tap the tailpipe lightly, and then use a carbon depos-

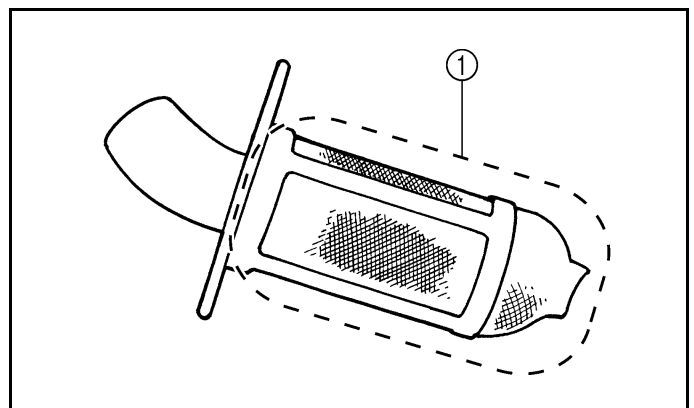

1. Spark arrester

4. Insert the tailpipe into the muffler and align the bolt holes.
5. Install and tighten the bolts.

 **WARNING**

POTENTIAL HAZARD

Improper cleaning of the spark arrester.

Hot exhaust system

WHAT CAN HAPPEN

Could injure the eyes.

Could cause burns.

Could cause carbon monoxide poisoning, possibly leading to death.

Could start a fire.

HOW TO AVOID THE HAZARD

When cleaning the spark arrester:

Always let the exhaust system cool prior to touching exhaust components.

Do not start the engine when cleaning the exhaust system.

EBU00296

Carburetor adjustment

The carburetor is a vital part of the engine and requires very sophisticated adjustment. Most adjusting should be left to a Yamaha dealer who has the professional knowledge and experience to do so. However, the idling speed may be performed by the owner as a part of the usual maintenance routine.

CAUTION: _____

The carburetor was set at the Yamaha factory after many tests. If the settings are disturbed by someone without sufficient technical knowledge, poor engine performance and damage may result.

EBU13020

Idle speed adjustment

NOTE:

A diagnostic tachometer must be used for this procedure.

1. Start the engine and warm it up for a few minutes at approximately 1,000 to 2,000 r/min. Occasionally rev the engine to 4,000 to 5,000 r/min. The engine is warm when it quickly responds to the throttle.
2. Connect the tachometer to the spark plug lead, and then set the idle to the specified idling speed by adjusting the throttle stop screw. Turn the screw in direction **a** to increase the engine speed, and in direction **b** to decrease the engine speed.

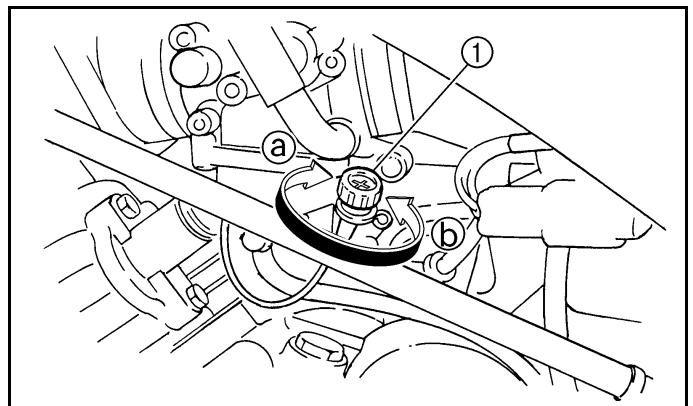

1. Throttle stop screw

EBU00303

Valve clearance adjustment

The correct valve clearance changes with use, resulting in improper fuel/air supply or engine noise. To prevent this, the valve clearance must be adjusted regularly. This adjustment however, should be left to a professional

EBU00307

Throttle lever adjustment

NOTE:

Adjust the engine idling speed before adjusting the throttle lever free play.

1. Loosen the locknut.
2. Turn the adjusting bolt until the throttle lever free play is 3–5 mm (0.12–0.20 in).
3. Tighten the locknut.

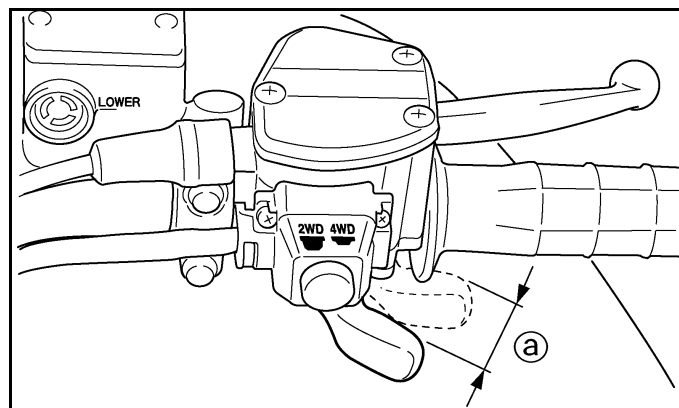
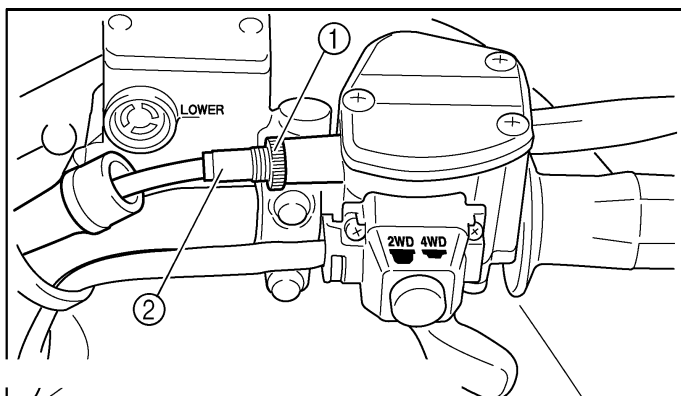

a. Throttle lever free play

EBU13090

Front brake pad check

Check the brake pads for damage and wear. If a brake pad thickness is less than 1 mm (0.04 in), have a Yamaha dealer replace the pads as a set.

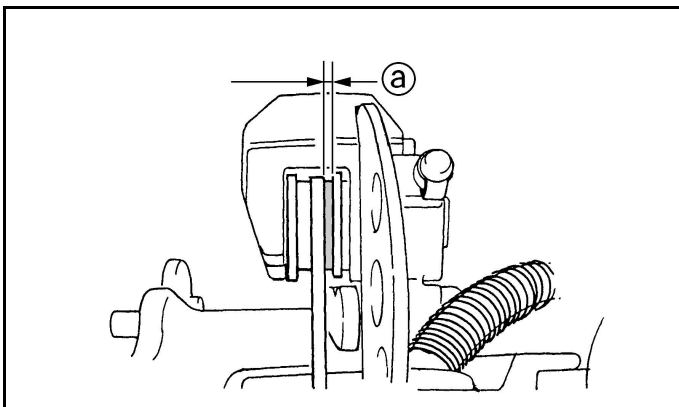

a. Brake pad thickness

NOTE: _____
The wheels need to be removed to check the

EBU00313

Rear brake shoe inspection

A wear indicator is provided on the rear brake. This indicator allows checking of brake shoe wear without disassembling the brake. Apply the rear brake and check the position of the indicator. If the indicator reaches the wear limit line, ask a Yamaha dealer to replace shoes as a set.

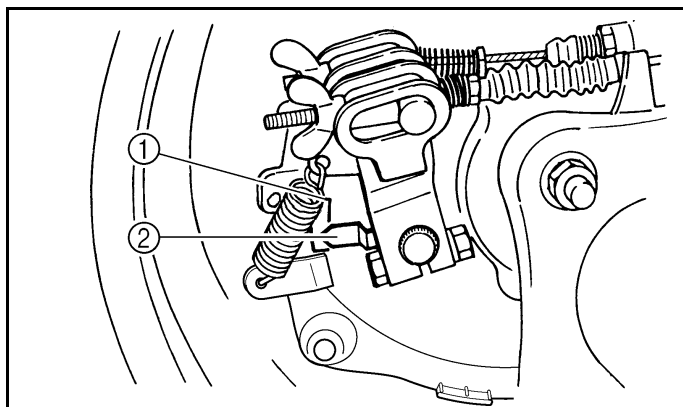

1. Wear limit line

2. Wear indicator

EBU13040

Brake fluid level check

Insufficient brake fluid may let air enter the brake system, possibly causing the brakes to become ineffective.

Before riding, check that the brake fluid is above the minimum level mark and replenish if necessary. A low brake fluid level may indicate worn brake pads and/or brake system leakage. If the brake fluid level is low, be sure to check the brake pads for wear and the brake system for leakage.

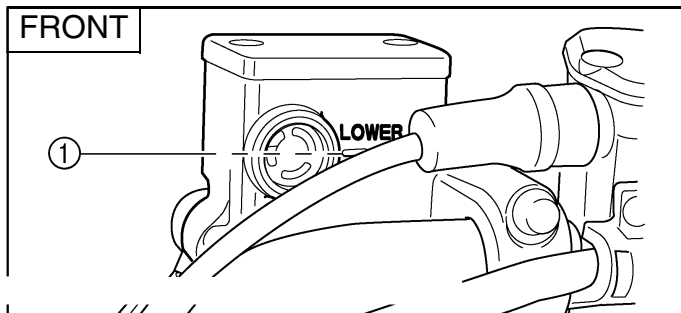

Observe these precautions:

- When checking the brake fluid level, make sure the top of the brake fluid reservoir is level.
- Use only the designated quality brake fluid, otherwise, the rubber seals may deteriorate, causing leakage and poor brake performance.

Recommended brake fluid: DOT 4

- Refill with the same type of brake fluid. Mixing fluids may result in a harmful chemical reaction and lead to poor brake performance.
- Be careful that water does not enter the brake fluid reservoir when refilling. Water will significantly lower the boiling point of the fluid and may result in vapor lock.

- Brake fluid may deteriorate painted surfaces or plastic parts. Always clean up spilled fluid immediately.
- Have a Yamaha dealer check the cause if the brake fluid level goes down.

EBU11860

Brake fluid replacement

Complete fluid replacement should be done only by trained Yamaha service personnel. Have a Yamaha dealer replace the following components during periodic maintenance or when they are damaged or leaking.

- Replace the oil seals every two years.
- Replace the brake hoses every four years.

EBU11870

Front brake lever free play

The front brake lever should have a free play of zero mm (zero in) at the lever end. If not, have a Yamaha dealer check the brake system.

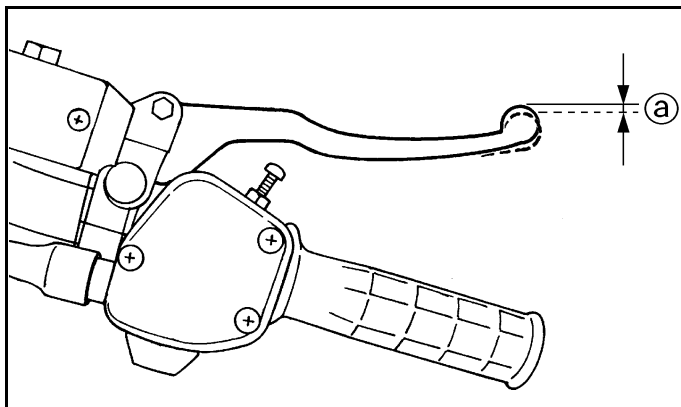

a. Front brake lever free play

⚠ WARNING

POTENTIAL HAZARD

Operating with improperly serviced or adjusted brakes.

WHAT CAN HAPPEN

You could lose braking ability, which could lead to an accident.

HOW TO AVOID THE HAZARD

After servicing:

- Make sure the brakes operate smoothly and that the free play is correct.
- Make sure the brakes do not drag.
- Make sure the brakes are not spongy. All air must be bled from the brake system.

Replacement of brake components requires professional knowledge. These

EBU01239

Rear brake pedal and lever adjustment

Brake pedal free play adjustment

1. Fully loosen the adjusting nut on the brake lever cable at the rear wheel.

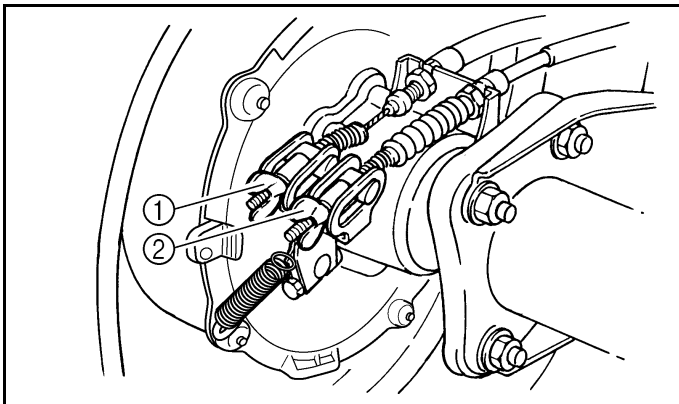

1. Adjusting nut (brake pedal cable)
2. Adjusting nut (brake lever cable)

2. Turn the adjusting nut on the brake pedal cable until the free play is 20–30 mm (0.79–1.18 in).

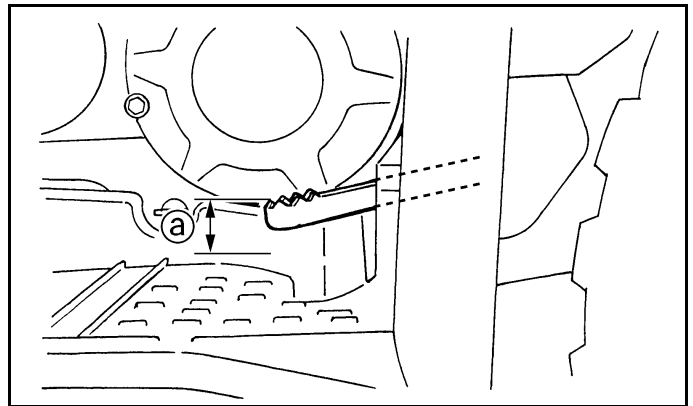

a. Brake pedal free play

Brake lever free play adjustment

1. Loosen the locknut and fully turn in the adjusting bolt at the brake lever.

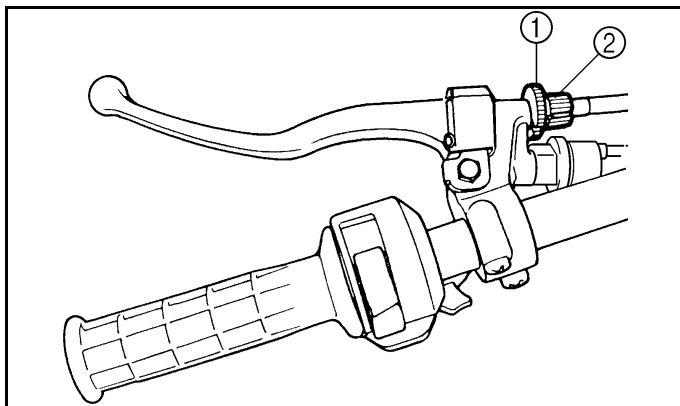

1. Locknut

2. Adjusting bolt

2. Turn in the adjusting nut on brake cable to provide a gap of 0–1 mm (0–0.04 in) between the brake camshaft lever and the pin.

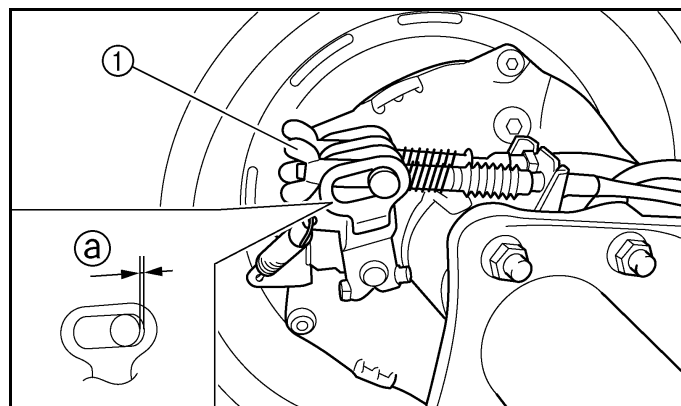

1. Adjusting nut (brake lever cable) a. Gap

3. Turn the adjusting bolt at the brake lever until the free play at the brake lever pivot is 3–5 mm (0.12–0.20 in).

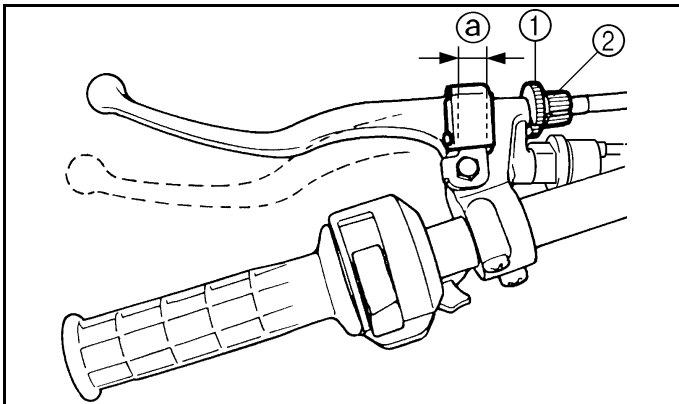

1. Locknut
2. Adjusting bolt
- a. Rear brake lever free play

4. Tighten the locknut.

⚠ WARNING

POTENTIAL HAZARD

Operating with improperly serviced or adjusted brakes.

WHAT CAN HAPPEN

You could lose braking ability, which could lead to an accident.

HOW TO AVOID THE HAZARD

After servicing:

- Make sure the brakes operate smoothly and that the free play is correct.
- Make sure the brakes do not drag.

Replacement of brake components requires professional knowledge. These procedures should be performed by a Yamaha dealer.

EBU12590

Adjusting the rear brake light switch

The rear brake light switch, which is activated by the brake pedal and rear brake lever, is properly adjusted when the brake light comes on just before braking takes effect. If necessary, adjust the brake light switch as follows.

1. Remove panel A. (See page 8-5 for panel removal and installation procedures.)
2. Turn the adjusting nut while holding the rear brake light switch in place. To make the brake light come on earlier, turn the adjusting nut in direction Ⓐ. To make the brake light come on later, turn the adjusting nut in direction Ⓑ.
3. Install the panel.

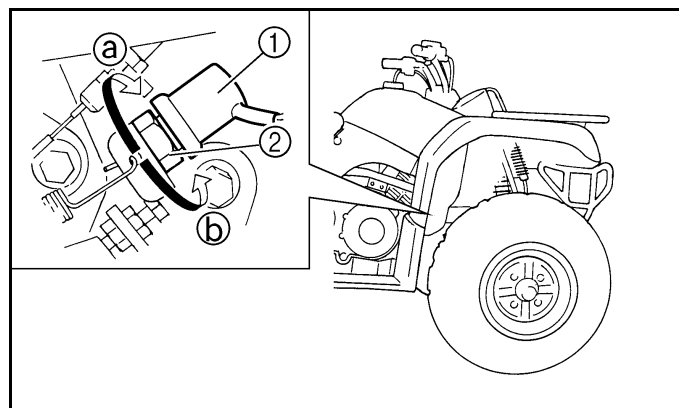

1. Rear brake light switch 2. Adjusting nut

EBU00356

Cable inspection and lubrication

WARNING

POTENTIAL HAZARD

Damaged control cables.

WHAT CAN HAPPEN

Corrosion can result when the outer covering of control cables becomes damaged. Cables can also become frayed or kinked. Operation of controls could be restricted, which could cause an accident or injury.

HOW TO AVOID THE HAZARD

Inspect cables frequently. Replace damaged cables.

Lubricate the inner cables and the cable ends. If the cables do not operate smoothly, ask a

EBU12600

Lubricating the brake levers and brake pedal

Lubricate the pivoting parts.

NOTE:

To access the brake pedal pivot, remove panel A. (See page 8-5 for panel removal and installation procedures.)

Recommended lubricant:

Lithium-soap-based grease
(all-purpose grease)

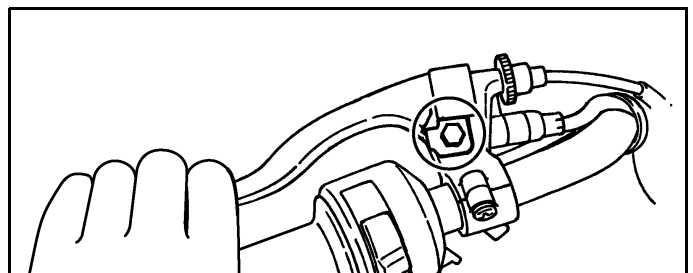

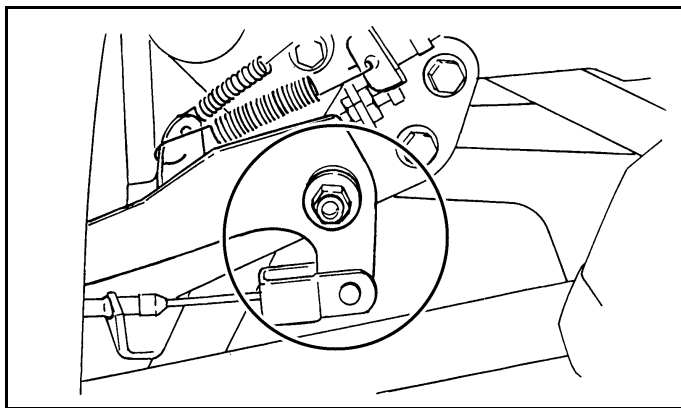

EBU01112

Wheel removal

1. Loosen the wheel nuts.
2. Elevate the ATV and place a suitable stand under the frame.
3. Remove the nuts from the wheel.
4. Remove the wheel.

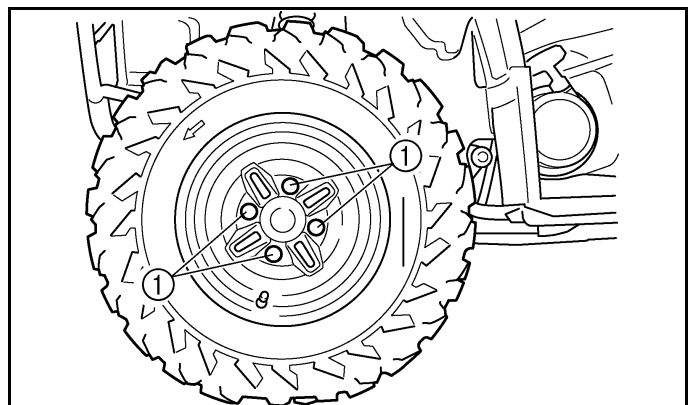

1. Nut (× 4)

EBU01121

Wheel installation

1. Install the wheel and the nuts.

NOTE:

- Tapered nuts are used for both the front and rear wheels. Install the nut with its tapered side towards the wheel.
- The arrow mark \uparrow on the tire must point toward the rotating direction of the wheel.

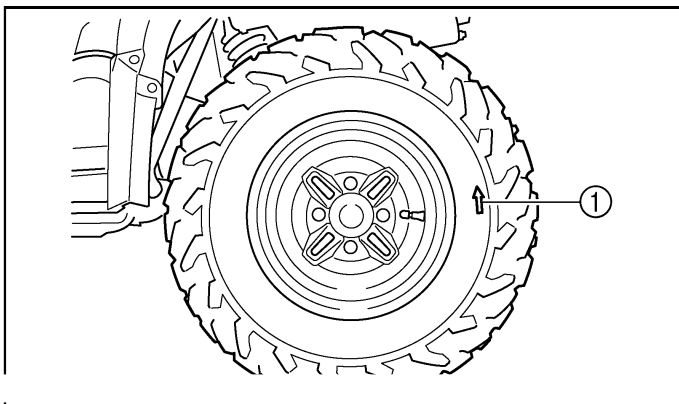

2. Lower the ATV so that the wheel is on the ground.

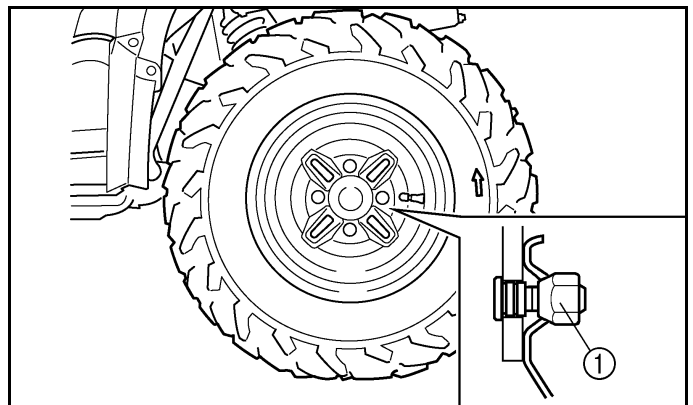

1. Tapered nut

3. Tighten the wheel nuts to the specified torque.

Wheel nut torque:

Front: 55 Nm (5.5 m·kgf, 40 ft·lbf)

Rear: 55 Nm (5.5 m·kgf, 40 ft·lbf)

EBU00380

Battery

This machine is equipped with a sealed-type battery. Therefore it is not necessary to check the electrolyte or add distilled water in the battery. If the battery seems to have discharged, consult a Yamaha dealer.

CAUTION:

Do not try to remove the sealing caps of the battery cells. You may damage the battery.

WARNING

POTENTIAL HAZARD

Failure to handle batteries or battery electrolyte carefully.

WHAT CAN HAPPEN

ou could be

HOW TO AVOID THE HAZARD

Avoid contact with skin, eyes or clothing. Always shield eyes when working near batteries. Keep out of reach of children.

Antidote:

EXTERNAL: Flush with water.

INTERNAL: Drink large quantities of water or milk. Follow with milk of magnesia, beaten egg or vegetable oil. Get prompt medical attention.

EYES: Flush with water for 15 minutes and get prompt medical attention. Keep batteries away from sparks, flames, cigarettes or other sources of ignition. Ventilate when charging or using in a closed space.

EBU00385

Battery maintenance

1. When the machine is not used for a month or longer, remove the battery and store it in a cool, dark place. Completely recharge the battery before reinstallation.

CAUTION: _____

A special battery charger (constant voltage/ampere or constant voltage) is required for recharging a sealed-type battery. Using a conventional battery charger may shorten the battery life.

2. Always make sure the connections are correct when putting the battery back in the machine.

EBU08760*

Fuse replacement

1. The main fuse case and the fuse box are located under the seat.
2. If a fuse is blown, turn off the main switch and install a new fuse of the specified amperage. Then turn on the switches. If the fuse immediately blows again, consult a Yamaha dealer.

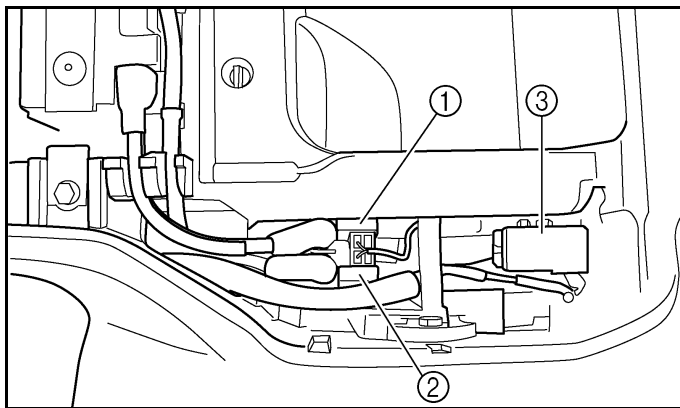

- 1. Main fuse
- 2. Spare main fuse
- 3. Fuse box

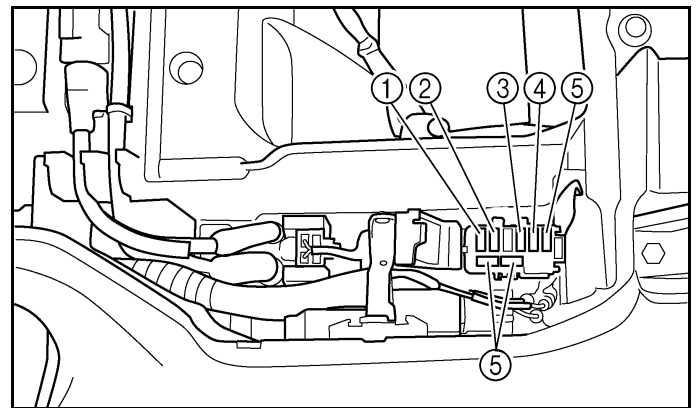

- 1. Headlight fuse
- 2. Ignition fuse
- 3. Four-wheel drive fuse
- 4. Signaling system fuse
- 5. Spare fuse (× 3)

Specified fuses:

Main fuse:	30 A
Headlight fuse:	15 A
Ignition fuse:	15 A
Four-wheel drive fuse:	3 A

⚠ WARNING

POTENTIAL HAZARD

Using an improper fuse.

WHAT CAN HAPPEN

An improper fuse can cause damage to the electrical system which could lead to a fire.

HOW TO AVOID THE HAZARD

Always use a fuse of the specified rating. Never use a material in place of the proper fuse.

CAUTION:

To prevent accidental short-circuiting, turn off the main switch when checking or replacing a fuse.

EBU14560

Replacing a headlight bulb

If a headlight bulb burns out, replace it as follows.

1. Remove the bulb holder cover at the rear of the headlight by pulling it off.

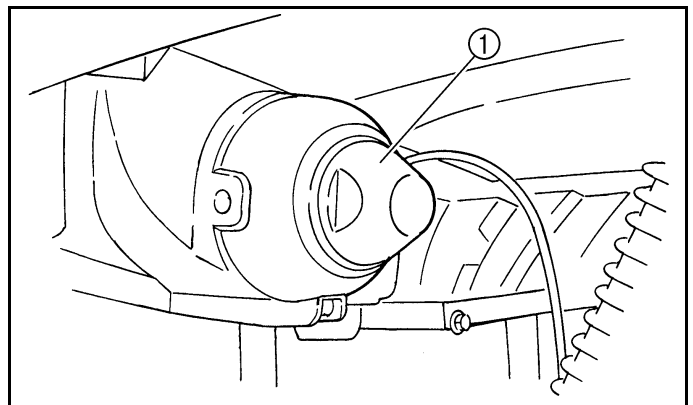

1. Headlight bulb holder cover

2. Remove the headlight bulb holder by turning it counterclockwise.

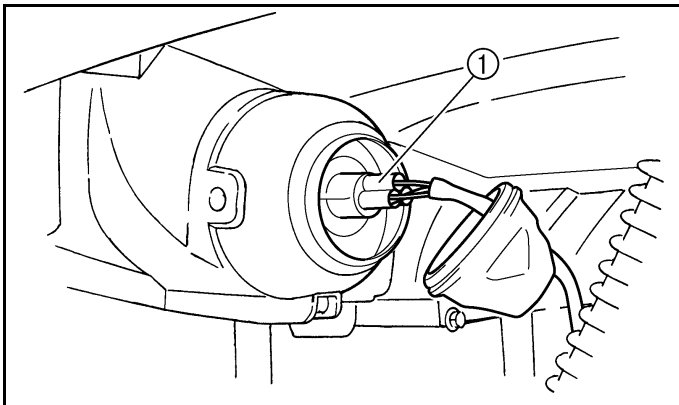

1. Headlight bulb holder

3. Remove the defective bulb by unhooking the headlight bulb holder tabs.

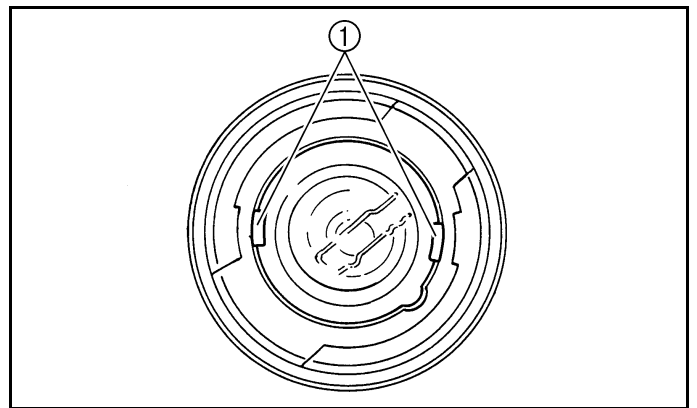

1. Headlight bulb holder tab (× 2)

⚠ WARNING

POTENTIAL HAZARD

A headlight bulb is hot when it is on and immediately after it is turned off.

WHAT CAN HAPPEN

You can be burned, or a fire could start if the bulb touches something flammable.

HOW TO AVOID THE HAZARD

Wait for the bulb to cool before touching or removing it.

4. Insert a new headlight bulb into the bulb holder, and then secure the bulb by hooking the tabs onto the bulb.

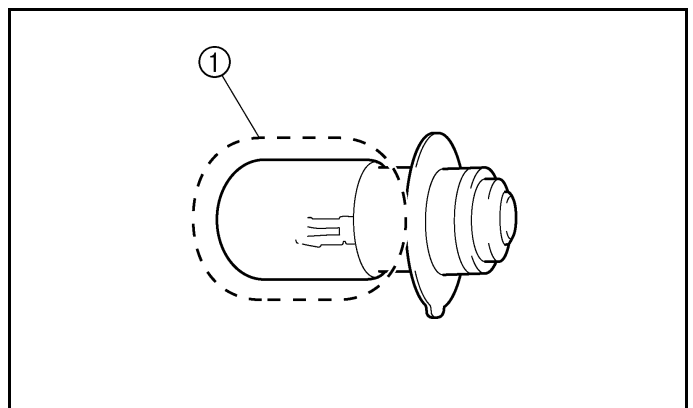

1. Do not touch the glass part of the bulb.

CAUTION:

Do not touch the glass part of the headlight bulb to keep it free from oil, otherwise the transparency of the glass, the luminosity of the bulb, and the bulb life will be adversely affected. Thoroughly clean off any dirt and fingerprints on the headlight bulb using a cloth moistened with alcohol or

5. Install the headlight bulb holder by turning it clockwise.
6. Install the headlight bulb holder cover at the rear of the headlight.

EBU01089

Headlight beam adjustment

CAUTION: _____

It is advisable to have a Yamaha dealer make this adjustment.

To raise the beam, turn the adjusting screw in direction ①.

To lower the beam, turn the adjusting screw in direction ②.

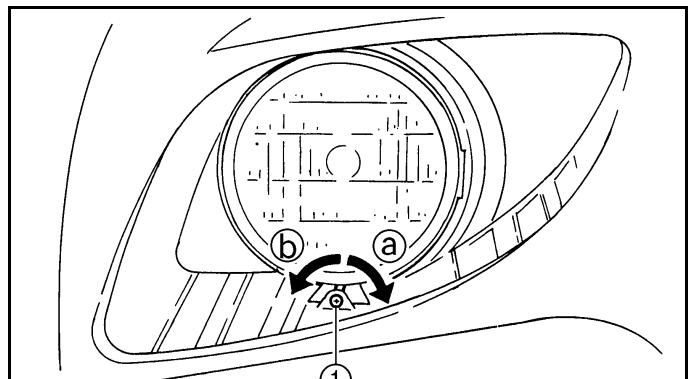

EBU01105

Tail/brake light bulb replacement

If the tail/brake light bulb burns out, have a Yamaha dealer replace it.

EBU00412

Troubleshooting

Although Yamaha machines receive a rigid inspection before shipment from the factory, trouble may occur during operation. Any problem in the fuel, compression, or ignition systems can cause poor starting and loss of power. The troubleshooting chart describes a quick, easy procedure for making checks. If your machine requires any repair, take it to a Yamaha dealer.

The skilled technicians at a Yamaha dealership have the tools, experience, and know-how to properly service your machine. Use only genuine Yamaha parts on your machine. Imitation parts may look like Yamaha parts, but they are often inferior. Consequently, they have a shorter service life and can lead to expensive repair bills.

 **WARNING**

POTENTIAL HAZARD

Checking the fuel system while smoking or near an open flame.

WHAT CAN HAPPEN

Fuel can ignite or explode, causing severe injury or property damage.

HOW TO AVOID THE HAZARD

Do not smoke when checking the fuel system. Make sure there are no open flames or sparks in the area, including pilot lights from water heaters or furnaces.

EBU04400

Troubleshooting chart

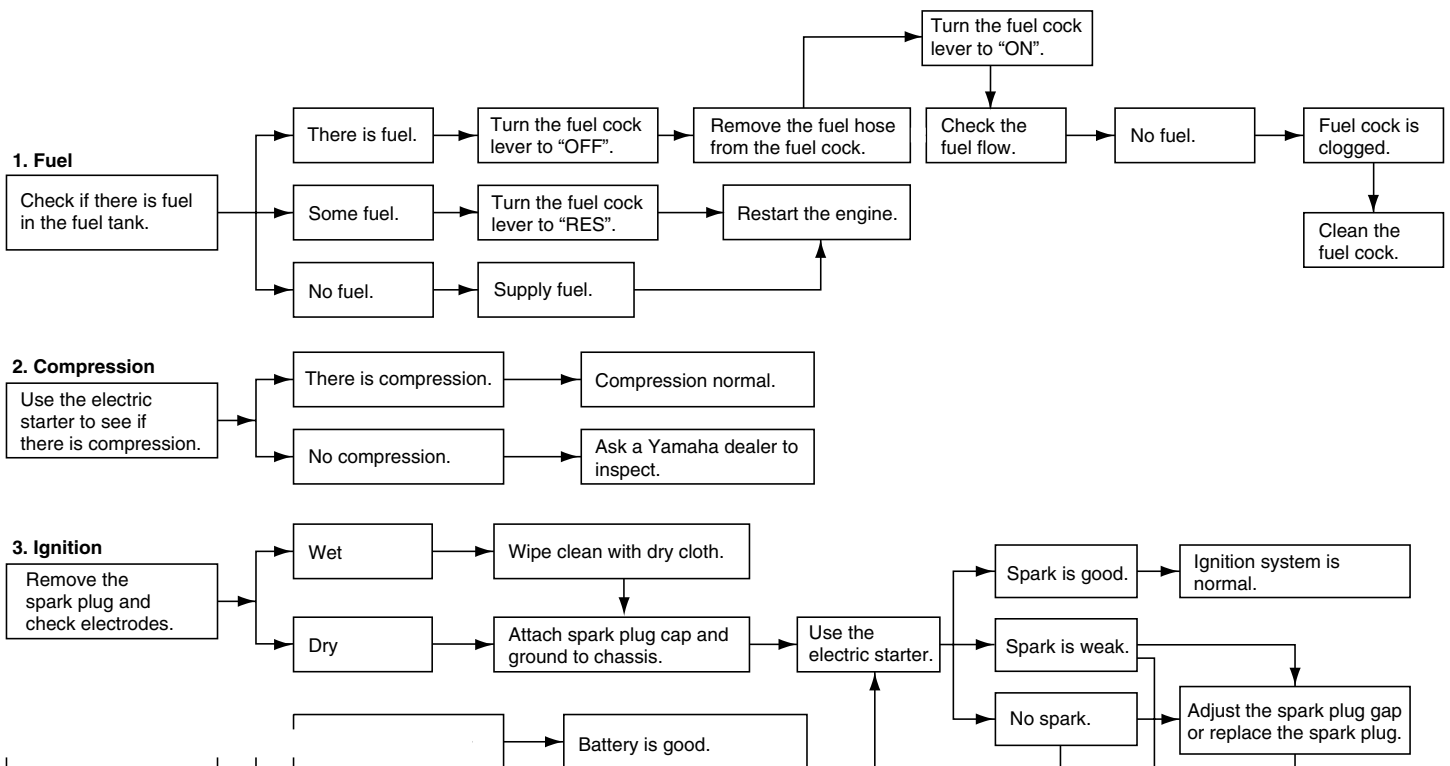

EBU00419

CLEANING AND STORAGE

A. CLEANING

Frequent, thorough cleaning of your machine will not only enhance its appearance but will improve its general performance and extend the useful life of many components.

1. Before cleaning the machine:
 - a. Block off the end of the exhaust pipe to prevent water entry. A plastic bag and strong rubber band may be used.
 - b. Make sure the spark plug and all filler caps are properly installed.
2. If the engine case is excessively greasy, apply degreaser with a paint brush. Do not apply degreaser to the wheel axles.
3. Rinse the dirt and degreaser off with a garden hose. Use only enough pressure

CAUTION:

Excessive water pressure may cause water seepage and deterioration of wheel bearings, brakes, transmission seals and electrical devices. Many expensive repair bills have resulted from improper high pressure detergent applications such as those available in coin-operated car washers.

4. Once the majority of the dirt has been hosed off, wash all surfaces with warm water and mild, detergent-type soap. An old toothbrush or bottle brush is handy for hard-to-get-at places.
5. Rinse the machine off immediately with clean water and dry all surfaces with a chamois, clean towel or soft absorbent cloth

6. Clean the seat with a vinyl upholstery cleaner to keep the cover pliable and glossy.
7. Automotive type wax may be applied to all painted and chrome plated surfaces. Avoid combination cleaner-waxes. Many contain abrasives which may mar the paint or protective finish. When finished, start the engine and let it idle for several minutes.

 **WARNING**

POTENTIAL HAZARD

Operation with wet brakes after washing.

WHAT CAN HAPPEN

Wet brakes may have reduced stopping ability, increasing the chance of an accident.

HOW TO AVOID THE HAZARD

Test the brakes after washing. Apply the brakes several times at slow speeds to let friction dry out the linings.

EBU00530

B. STORAGE

Long term storage (60 days or more) of your machine will require some preventive procedures to guard against deterioration. After thoroughly cleaning the machine, prepare for storage as follows:

1. Fill the fuel tank with fresh fuel and add the specified amount of Yamaha Fuel Stabilizer and Conditioner or an equivalent product.

Specified amount:

1 oz of stabilizer to each gallon of fuel
(or 7.5 cc of stabilizer to each liter of fuel)

2. Remove the spark plug, pour about one tablespoon of SAE 10W30 or 20W40 motor oil in the spark plug hole and reinstall the spark plug. Ground the spark plug wire and turn the engine over several times to coat the cylinder wall with oil.
3. Lubricate all control cables.
4. Block up the frame to raise all wheels off the ground.
5. Tie a plastic bag over the exhaust pipe outlet to prevent moisture from entering.
6. If storing in a humid or salt-air atmosphere, coat all exposed metal surfaces with a light film of oil. Do not apply oil to any rubber parts or the seat cover.

NOTE: _____
Use of fuel stabilizer and conditioner eliminates system. Con-

7. Remove the battery and charge it. Store it in a dry place and recharge it once a month. Do not store the battery in an excessively warm or cold place (less than 0 °C (30 °F) or more than 30 °C (90 °F)).

NOTE: _____
Make any necessary repairs before storing the machine.

EBU00428

SPECIFICATIONS

Model	YFM350FA
Dimensions: Overall length Overall width Overall height Seat height Wheelbase Minimum ground clearance Minimum turning radius	1,984 mm (78.1 in) 1,085 mm (42.7 in) 1,120 mm (44.1 in) 827 mm (32.6 in) 1,233 mm (48.5 in) 245 mm (9.65 in) 3,000 mm (118.1 in)
Basic weight: With oil and full fuel tank	258 kg (569 lb)
Engine: Engine type Cylinder arrangement Displacement Compression ratio	Air cooled 4-stroke, SOHC Forward-inclined single cylinder 348.9 cm ³ 83.0 × 64.5 mm (3.27 × 2.54 in) 9.20 :1

Model	YFM350FA
-------	----------

Engine oil:
Type

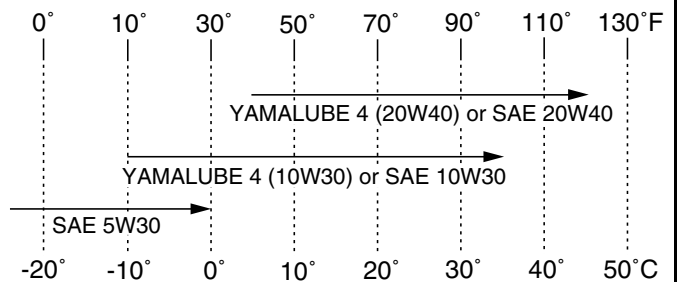

Recommended engine oil classification:

API Service SE, SF, SG type or higher

CAUTION:

In order to prevent clutch slippage (since the engine oil also lubricates the clutch), do not mix any chemical additives. Do not use oils with a diesel specification of "CD" or oils of a higher quality than specified. In addition, do not use oils labeled "ENERGY CONSERVING II" or higher.

Model	YFM350FA
Final gear case oil: Type Quantity: Periodic oil change	SAE80 API GL-4 Hypoid gear oil 0.23 L (0.20 Imp qt, 0.24 US qt)
Differential gear case oil: Type Quantity: Periodic oil change	SAE80 API GL-4 Hypoid gear oil 0.35 L (0.31 Imp qt, 0.37 US qt)
Air filter:	Wet element
Fuel: Type Fuel tank capacity Fuel reserve amount	UNLEADED GASOLINE ONLY 13.5 L (2.97 Imp gal, 3.57 US gal) 3.3 L (0.73 Imp gal, 0.87 US gal)
Carburetor: Type/quantity Manufacturer	BSR33 / 1 MIKUNI
Spark plug:	DR8EA / NGK 0.6 - 0.7 mm (0.02 - 0.03 in)

Model	YFM350FA
Transmission: Primary reduction system Secondary reduction system Secondary reduction ratio Transmission type Operation Forward gear Reverse gear	V-belt Shaft drive 41/21 × 24/18 × 33/9 (9.545) V-belt automatic Left hand operation 35/20 (1.750) 26/15 (1.733)
Chassis: Frame type Caster angle Trail	Steel tube frame 4° 21 mm (0.83 in)
Tire: Type Size	Tubeless AT25 × 8 - 12 AT25 × 10 - 12
Brake: type	Dual disc brake Right hand operation

Model	YFM350FA
Suspension: Front suspension Rear suspension	Double wishbone Swingarm (monocross)
Shock absorber: Front shock absorber Rear shock absorber	Coil spring / oil damper Coil spring / oil damper
Wheel travel: Front wheel travel Rear wheel travel	160 mm (6.30 in) 180 mm (7.09 in)
Electrical: Ignition system Generator system Battery type Battery capacity	DC-C.D.I. A.C. magneto YTX14AH 12 V, 12 Ah
Headlight type:	Krypton bulb

Model	YFM350FA
Bulb voltage, wattage × quantity:	
Headlight	12 V, 30/30 W × 2
Tail/brake light	12 V, 5/21 W × 1
Neutral indicator light	12 V, 1.7 W × 1
Reverse indicator light	12 V, 1.7 W × 1
Oil temperature warning light	12 V, 1.7 W × 1
Four-wheel drive indicator light	12 V, 1.7 W × 1
Fuses:	
Main fuse	30 A
Headlight fuse	15 A
Ignition fuse	15 A
Four-wheel drive fuse	3 A
Signaling system fuse	10 A

EBU00430

NOISE REGULATION

TAMPERING WITH NOISE CONTROL SYSTEM PROHIBITED:

Federal law prohibits the following acts or the causing thereof: (1) The removal or rendering inoperative by any person other than for purposes of maintenance, repair, or replacement of any device or element of design incorporated into any new vehicle for the purpose of noise control prior to its sale or delivery to the ultimate purchaser or while it is in use or (2) the use of the vehicle after such device or element of design has been removed or rendered inoperative by any person.

“AMONG THOSE ACTS PRESUMED TO CONSTITUTE TAMPERING ARE THE ACTS LISTED BELOW.”

These acts include tampering with the following systems; i.e., modification, removal, etc.

Exhaust system	Muffler Exhaust pipe Silencer
Intake system	Air cleaner case Air cleaner element Intake duct

EBU13651

MAINTENANCE RECORD

Copies of work orders and/or receipts for parts you purchase and install will be required to document maintenance done in accordance with the warranty. The chart below is printed only as a reminder to you that the maintenance work is required. It is not acceptable proof of maintenance work.

MAINTENANCE INTERVAL	DATE OF SERVICE	SERVICING DEALER NAME AND ADDRESS	REMARKS
1 Month			
3 Months			
6 Months			
12 Months			
18 Months			
24 Months			
30 Months			
36 Months			
42 Months			

EBU00432

YAMAHA MOTOR CORPORATION, U.S.A. ATV LIMITED WARRANTY

Yamaha Motor Corporation, U.S.A. hereby warrants that new Yamaha ATV purchased from an authorized Yamaha ATV dealer in the continental United States will be free from defects in material and workmanship for the period of time stated herein, subject to certain stated limitations.

THE PERIOD OF WARRANTY for Yamaha ATV's shall be six (6) months from the date of purchase.

DURING THE PERIOD OF WARRANTY any authorized Yamaha ATV dealer will, free of charge, repair or replace any part adjudged defective by Yamaha due to faulty workmanship or material from the factory. Parts used in warranty repairs will be warranted for the balance of the product's warranty period. All parts replaced under warranty become property of Yamaha Motor Corp. U.S.A.

GENERAL EXCLUSIONS from this warranty shall include any failures caused by:

- a. Competition or racing use.
- b. Installation of parts or accessories that are not qualitatively equivalent to genuine Yamaha parts.
- c. Abnormal strain, neglect, or abuse.
- d. Lack of proper maintenance.
- e. Accident or collision damage.
- f. Modification to original parts.
- g. Damage due to improper transportation.

SPECIFIC EXCLUSIONS from this warranty shall include parts replaced due to normal wear or routine maintenance; such as spark plugs, oil, oil filter, air filter, and brake shoes.

THE CUSTOMER'S RESPONSIBILITY under this warranty shall be to:

1. Operate and maintain the ATV as specified in the appropriate owner's manual;
2. Give notice to an authorized Yamaha ATV dealer of any and all apparent defects within ten (10) days after discovery, and make the machine available at that time for inspection and repairs at such dealer's place of business.

WARRANTY TRANSFER: To transfer the warranty from the original purchaser to any subsequent purchaser(s), it is imperative that the machine be inspected and registered for warranty by an authorized Yamaha ATV dealer. In order for this warranty to remain in effect, this inspection and registration must take place within ten (10) days after transfer. An inspection and registration fee will be charged for this service.

YAMAHA MOTOR CORPORATION, U.S.A. MAKES NO OTHER WARRANTY OF ANY KIND, EXPRESSED OR IMPLIED. ALL IMPLIED WARRANTIES OF MERCHANTABILITY AND FITNESS FOR A PARTICULAR PURPOSE WHICH EXCEED THE OBLIGATIONS AND TIME LIMITS STATED IN THIS WARRANTY ARE HEREBY DISCLAIMED BY YAMAHA MOTOR CORPORATION, U.S.A. AND

SOME STATES DO NOT ALLOW LIMITATIONS ON HOW LONG AN IMPLIED WARRANTY LASTS, SO THE ABOVE LIMITATION MAY NOT APPLY TO YOU. ALSO EXCLUDED FROM THIS WARRANTY ARE ANY INCIDENTAL OR CONSEQUENTIAL DAMAGES INCLUDING LOSS OF USE. SOME STATES DO NOT ALLOW THE EXCLUSION OR LIMITATION OF INCIDENTAL OR CONSEQUENTIAL DAMAGES, SO THE ABOVE EXCLUSION MAY NOT APPLY TO YOU.

THIS WARRANTY GIVES YOU SPECIFIC LEGAL RIGHTS, AND YOU MAY ALSO HAVE OTHER RIGHTS WHICH VARY FROM STATE TO STATE.

YAMAHA MOTOR CORPORATION, U.S.A.
P.O. Box 6555
Cypress, California 90630

WARRANTY QUESTIONS AND ANSWERS

- Q. What costs are my responsibility during the warranty period?
- A. The customer's responsibility includes all costs of normal maintenance services, non-warranty repairs, accident and collision damages, and oil, oil filters, air filters, spark plugs, and brake shoes.
- Q. What are some examples of "abnormal" strain, neglect, or abuse?
- A. These terms are general and overlap each other in areas. Specific examples include: Running the machine out of oil, sustained high-rpm, full-throttle, operating the machine with a broken or damaged part which causes another part to fail, damage or failure due to improper or careless transportation and or tie down. If you have any specific questions on operation or maintenance, please contact your dealer for advice.
- Q. Does the warranty cover incidental costs such as towing or transportation due to a failure?
- A. No. The warranty is limited to repair of the machine itself.
- Q. May I perform any or all of the recommended maintenance shown in the Owner's Manual instead of having the dealer do them?
- A. Yes, if you are a qualified mechanic and follow the procedures specified in the Owner's and Service Manual. We do recommend, however, that items requiring special tools or equipment be done by Yamaha ATV dealer.
- Q. Will the warranty be void or cancelled if I do not operate or maintain my new ATV exactly as specified in the Owner's Manual?
- A. No. The warranty on a new ATV cannot be "voided" or "cancelled." **However, if a particular failure is caused by operation or maintenance other than as shown in the Owner's Manual, that failure may not be covered under warranty.**
- Q. What responsibility does my dealer have under this warranty?
- A. Each Yamaha ATV dealer is expected to:
1. Completely set up every new machine before sale.
 2. Explain the operation, maintenance, and warranty requirements to your satisfaction at any later date.

CUSTOMER SERVICE

If your machine requires warranty service, you must take it to any authorized Yamaha ATV dealer within the continental United States. Be sure to bring your warranty registration card or other valid proof of the original date of purchase. If a question or problem arises regarding warranty, first contact the owner of the dealership. Since all warranty matters are handled at the dealer level, this person is in the best position to help you. If you are still not satisfied and require additional assistance, please write:

YAMAHA MOTOR CORPORATION U.S.A.
CUSTOMER RELATIONS DEPARTMENT
P.O. Box 6555
Cypress, California 90630

When contacting Yamaha Motor Corporation, U.S.A. don't forget to include any important information such as names, addresses, model, V.I.N. (frame number), dates, and receipts.

CHANGE OF ADDRESS

The federal government requires each manufacturer of a motor vehicle to maintain a complete, up-to-date list of all first purchasers against the possibility of a safety-related defect and recall. This list is compiled from the purchase registrations sent to Yamaha Motor Corporation, U.S.A. by the selling dealer at the time of your purchase.

If you should move after you have purchased your new ATV, please advise us of your new address by sending a postcard listing your ATV model name, V.I.N. (frame number), dealer number (or dealer's name) as it is shown on your warranty card, your name and new mailing address. Mail to:

YAMAHA MOTOR CORPORATION, U.S.A.
P.O. Box 6555
Cypress, California 90630
Attention: Warranty Department

EBU00435

YAMAHA EXTENDED SERVICE (Y.E.S.)

Keep your Yamaha protected even after your warranty expires with genuine Yamaha Extended Service (Y.E.S.).

- Y.E.S. is designed and administered by Yamaha Motor Corporation to provide maximum owner satisfaction. You get uninterrupted factory-backed coverage for extra peace of mind.
- Y.E.S. is flexible. You choose the plan that's right for you: 12 months, 24 months, or 36 months beyond your warranty period.
- Y.E.S. is designed and administered by the same Yamaha people who handle your warranty – and it shows in the comprehensive coverage benefits. There are no mileage limitations. Coverage isn't limited to "moving parts" or the "drive train" like many other plans. And Y.E.S. covers manufacturing defects just like the warranty. See the sample contract at your Yamaha dealer to see how comforting uninterrupted factory-backed protection can be.
- You don't have to pay anything for covered repairs. There's no deductible to pay, and repairs aren't "pro-rated." You don't have any "out-of-pocket" expenses

- In addition, Travel and Recreation Interruption Protection (TRIP) is included at no extra cost. TRIP gives you up to \$150 reimbursement per occurrence for any reasonable expenses you incur because your Yamaha needs covered service: replacement vehicle rental, emergency towing, phone calls, even food and lodging when you are away from home. This superb coverage goes into effect when you purchase Y.E.S., so it applies to any warranty repairs as well as covered repairs during your entire Y.E.S. plan period.
- Y.E.S. coverage is honored at any authorized Yamaha dealer nationwide.
- Y.E.S. coverage is transferable to a new owner if you sell or trade-in. That can make your Yamaha much more valuable!

This excellent Y.E.S. plan coverage is only available to Yamaha owners like you, and only while your Yamaha is still within the Yamaha Limited Warranty period. So visit your authorized Yamaha dealer to get all the facts. He can show you how easy it is to protect your investment with Yamaha Extended Service.

We urge you to act now. You'll get the excellent benefits of TRIP coverage right away, and you'll rest easy knowing you'll have strong factory-backed protection even after your Yamaha Limited Warranty expires. You can also save money: Y.E.S. costs less within the first 90 days after you buy your Yamaha. See your dealer today!

A special note:

If visiting your dealer isn't convenient, contact Yamaha with your Primary ID number (your frame number). We'll be happy to help you get the Y.E.S. coverage you need.

Yamaha Service Marketing
P.O. Box 6555
Cypress, CA 90630

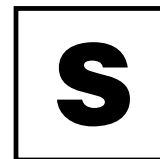
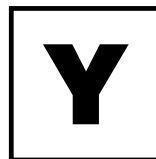

YAMAHA EXTENDED SERVICE

EBU00437

PROTECT YOUR INVESTMENT
Use Genuine YAMAHA Parts And Accessories

See your Authorized YAMAHA Dealer for a Genuine YAMAHA Service Manual.

Review this IMPORTANT SAFETY CARD
is not attached, call 1-800-344-6418).

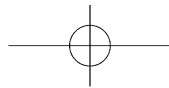

Dear New Yamaha ATV Owner:

CONGRATULATIONS ON THE PURCHASE OF YOUR NEW YAMAHA ATV. You have purchased a quality Yamaha product that, with proper use and care, will provide hours of riding pleasure. **BEFORE YOU OPERATE YOUR NEW ATV, Yamaha recommends these important points:**

- READ YOUR OWNER'S MANUAL
- A CHILD UNDER 6 YEARS OLD SHOULD NOT OPERATE AN ATV WITH ENGINE SIZE 50CC OR GREATER
- A CHILD UNDER 12 YEARS OLD SHOULD NOT OPERATE AN ATV WITH ENGINE SIZE 70CC OR GREATER
- A CHILD UNDER 16 YEARS OLD SHOULD NOT OPERATE AN ATV WITH ENGINE SIZE GREATER THAN 90CC
- TAKE THE FREE HANDS-ON TRAINING COURSE OFFERED BY YAMAHA – ASK YOUR DEALER FOR DETAILS OR CALL 1-800-887-2887

If you have any questions about these points, **or if you purchased your ATV from an authorized Yamaha dealership and were not informed of the age recommendation for your ATV by the dealership**, please fill out the information below and mail this card to yamaha_today.

CAREFULLY

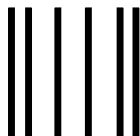
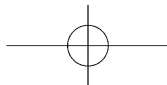

NO POSTAGE
NECESSARY
IF MAILED
IN THE
UNITED STATES

BUSINESS REPLY MAIL
FIRST CLASS PERMIT NO. 4 CYPRESS, CA

POSTAGE WILL BE PAID BY ADDRESSEE

YAMAHA MOTOR CORPORATION U.S.A.

FM DMA 6555

