

122

***WaveRunner GP***  
GP800W

**OWNER'S/OPERATOR'S  
MANUAL**

**READ THIS MANUAL  
CAREFULLY**



**U.S.A. Edition**  
**YAMAHA MOTOR CORPORATION, U.S.A.**

**LIT-18626-03-06 ●**



## TO THE OWNER

Thank you for choosing a Yamaha Water Vehicle. This Owner's Manual contains information you will need for proper operation, maintenance, and care. A thorough understanding of these simple instructions will help you to obtain maximum enjoyment from your new Yamaha. If you have any questions about the operation or maintenance of your water vehicle, please consult a Yamaha dealer.

**YAMAHA MOTOR CO., LTD.**

Because Yamaha has a policy of continuing product improvement, this product may not be exactly as described in this Owner's Manual. Specifications are subject to change without notice.

This manual should be considered a permanent part of this water vehicle and should remain with it even if the vehicle is subsequently sold.

### **IMPORTANT MANUAL INFORMATION:**

In this manual, information of particular importance is distinguished in the following ways:



The Safety Alert Symbol means **ATTENTION! BECOME ALERT! YOUR SAFETY IS INVOLVED!**

### **WARNING**

**Failure to follow WARNING instructions could result in severe injury or death to the machine operator, a bystander, or a person inspecting or repairing the water vehicle.**

### **CAUTION:**

**A CAUTION indicates special precautions that must be taken to avoid damage to the water vehicle.**

### **NOTE:**

**A NOTE provides key information to make procedures easier or clearer.**

**WAVERUNNER GP  
OWNER'S/OPERATOR'S MANUAL  
©1998 by Yamaha Motor Co., Ltd.  
1st Edition, March 1998  
All rights reserved. Any reprinting  
or unauthorized use without  
the written permission of  
Yamaha Motor Corporation,  
U.S.A. is expressly prohibited.  
Printed in Japan  
P/N LIT-18626-03-06**



## CONTENTS



**GENERAL AND SAFETY INFORMATION**

**1**



**FEATURE AND FUNCTIONS**

**2**



**OPERATION AND RIDING**

**3**



**MAINTENANCE AND CARE**

**4**



**TROUBLESHOOTING AND  
EMERGENCY PROCEDURE**

**5**



**INDEX**

**6**

**READ THIS OWNER'S / OPERATOR'S MANUAL CAREFULLY  
BEFORE OPERATING YOUR WATER VEHICLE.**



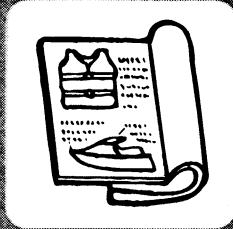

E

EJU00274

1

# Chapter 1 GENERAL AND SAFETY INFORMATION

- IDENTIFICATION NUMBER**
- RECORDS** ..... 1-1
  - PRI-I.D. number ..... 1-1
  - Hull identification number ..... 1-1
  - Engine number ..... 1-1
  
- IMPORTANT LABELS** ..... 1-2
  - Location ..... 1-2
  - Labels ..... 1-3
  
- SAFETY INFORMATION** ..... 1-6
  - Limitations on who may operate the vehicle ..... 1-6
  - Cruising limitations ..... 1-7
  - Operational requirements ..... 1-7
  - Hazard information ..... 1-11
  - Water vehicle characteristics ..... 1-11
  
- RULES OF THE ROAD** ..... 1-12
  - Steering and sailing rules and sound signals ..... 1-12
  - Rules when encountering vessels.. 1-13
  - Other special situations ..... 1-14
  
- TO GET MORE BOATING SAFETY INFORMATION** ..... 1-16
  
- ENJOY YOUR WATER VEHICLE RESPONSIBLY** ..... 1-16
  
- FUEL REQUIREMENTS** ..... 1-17
  - Gasoline (petrol) ..... 1-17
  - Engine oil ..... 1-17



E

EJU00275

## IDENTIFICATION NUMBER RECORDS

Record your Primary, H.I.N. I.D., and engine numbers in the spaces provided, to assist you in ordering spare parts from your Yamaha Water Vehicle dealer. Also record and keep these I.D. numbers in a separate place in case your water vehicle is stolen.

EJU00281

### PRI-I.D. NUMBER

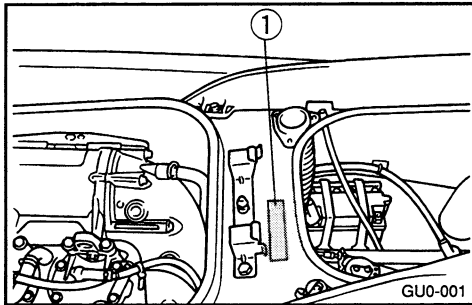

MODEL	
<input type="text"/>	
PRI-I.D. CODE	SERIAL No.
<input type="text"/>	<input type="text"/>

The Primary I.D. number is stamped on a label ① attached to the deck under the rear seat.

EJU00286\*

### HULL IDENTIFICATION NUMBER(H.I.N)

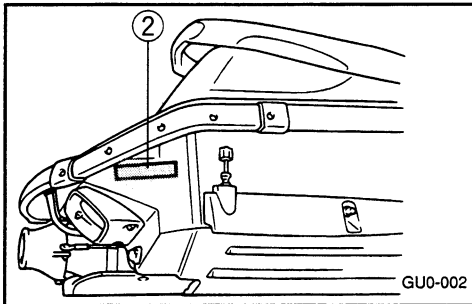

<input type="text"/>	<input type="text"/>	<input type="text"/>	<input type="text"/>	<input type="text"/>	<input type="text"/>	<input type="text"/>	<input type="text"/>	<input type="text"/>	<input type="text"/>
----------------------	----------------------	----------------------	----------------------	----------------------	----------------------	----------------------	----------------------	----------------------	----------------------

The H.I.N. is stamped on a plate ② attached to the hull beside the exhaust outlet.

EJU00288\*

### ENGINE NUMBER

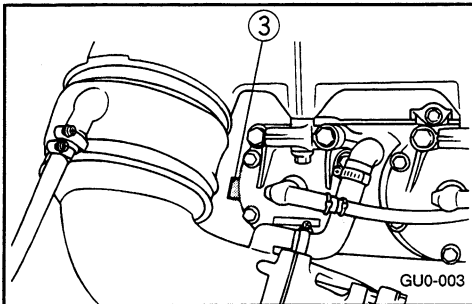

YAMAHA		<input type="text"/>									
<input type="text"/>		<input type="text"/>									
<small>YAMAHA MOTOR CO., LTD. MADE IN JAPAN PAYE D'ORIGINE JAPON</small>											

The Engine serial number is stamped on a label ③ attached to the crankcase.





E

EJU00293

## IMPORTANT LABELS

### LOCATION

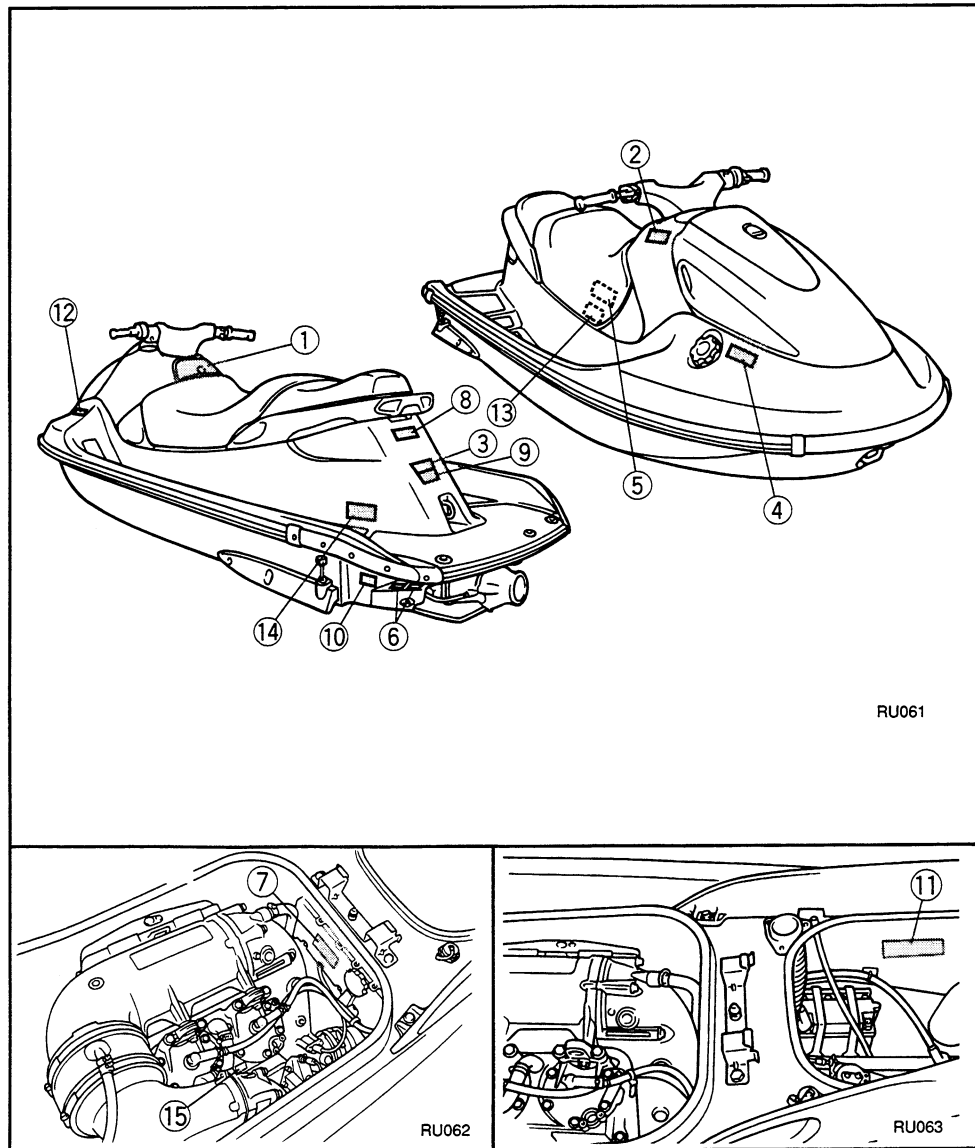



## LABELS

### Warning labels

①

**⚠ WARNING**

SEVERE INJURY OR DEATH MAY RESULT IF YOU IGNORE ANY OF THE FOLLOWING.

- Read the Owner's Manual, the Riding Practice Tips, the Riding Instructions card, and all labels before operating.
- This vehicle is recommended only for operators 16 and older with valid motor vehicle license. Adults must supervise use by minors. Check state laws for minimum age requirements.
- Vehicle capacity : 1 operator and 1 passenger. Do not exceed 353 lb (160kg), including any cargo. Overloading can make the vehicle more difficult to control, which can lead to an accident.
- Wear a USCG-approved personal flotation device.
- Wear a wetsuit to protect against injuries to orifices (rectum and vagina) from strong streams of water from the jet nozzle, or from impact with the water surface. A wetsuit also helps protect against hypothermia and abrasions.
- Attach the engine stop switch lanyard to your left wrist before operating.
- You must know and follow all federal, state, and local boating laws.
- Never ride after drinking alcohol or taking drugs.
- You need engine power to turn. Releasing throttle lever or shutting off engine can cause you to hit an obstacle you are attempting to avoid.
- Check throttle and steering for proper operation before starting the engine. Malfunctioning controls can cause accidents.
- Open the front seat and the front storage compartment to ventilate fuel vapors from the engine compartment before starting the engine. Do not start the engine if there is a fuel leak or loose electrical connection.
- Do not operate in less than 2 ft (60 cm) of water.
- Keep a safe distance from swimmers, other watercraft, and obstructions.
- Never attempt jumps with this water vehicle.
- Do not travel far away without another watercraft or boat with you.
- Stop engine before removing debris from jet intake on bottom of hull. Keep hands, feet, hair, and all other parts of your body and clothing away from jet intake while engine is running.
- Passenger should firmly hold on to the operator and place feet on the footrest floor. Otherwise, passenger could lose balance and fall.

YAMAHA GP7-U416C-40

②

**⚠ WARNING**

- Strong streams of water from the jet nozzle can be dangerous, and can result in serious injury when directed at the body orifices (rectum and vagina).
- Do not apply throttle when someone is in the water behind the jet nozzle or when a passenger is climbing on.

YAMAHA GJ1-U415E-01

③

**⚠ WARNING**

- Strong streams of water from the jet nozzle can be dangerous, and can result in serious injury when directed at the body orifices (rectum and vagina).
- Wear a wetsuit to protect body.
- Do not board vehicle if operator is applying throttle.

GP7-U411A-10

④

**⚠ WARNING**

Gasoline is highly flammable and explosive. A fire or explosion can cause severe injury or death. Shut off engine. Refuel in well ventilated area away from flames or sparks. Do not smoke. Avoid spilling gasoline. Wipe up spilled gasoline immediately.

**GASOLINE ONLY**

YAMAHA GP7-U416B-00

⑤

**⚠ WARNING**

Do not add gasoline to the oil tank. Fire or explosion could result.

YAMAHA GA9-U416F-00



⑥

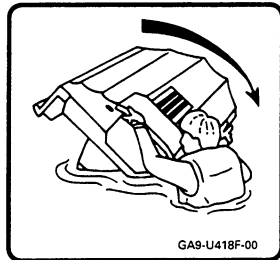

GAS-U418F-00

⑥

**⚠ WARNING**

**IMPROPER UPRIGHTING CAN CAUSE INJURY.**

- Shut off engine.
- Do not put hand in intake grille.
- Watch so you are not hit by vehicle as it comes over.

**TO TURN OVER:**

- Pull vehicle over with left hand on ride plate while pushing down on gunwale with right hand/foot.

YAMAHA

⑦

**⚠ WARNING**

Do not touch or remove electrical parts when starting or running the engine.

YAMAHA 6R7-83623-40

**Caution labels**

⑧

**CAUTION**

**HAND GRIPS ARE FOR BOARDING ONLY.**

- Do not use to tow objects, lift vehicle, or attach tie downs.
- Damage could occur.

YAMAHA GJ1-6418C-00

⑨

**CAUTION**

Cleat is for mooring only. Do not use cleat to lift vehicle. Damage could occur.

GP7-U411A-10

⑩

**CAUTION**

**BEFORE LAUNCHING:**  
See Owner's Manual for draining procedure. Make sure two drain plugs at the back of the hull are tightened securely.

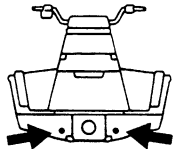

YAMAHA GAS-U419C-00

⑪

**CAUTION**

**BATTERY REMOVAL:**

- Disconnect both battery leads and the breather pipe before removing battery.

**BATTERY INSTALLATION:**

- Connect red lead to positive (+) terminal. Connect black lead to negative (-) terminal. Reversing leads will damage electrical system.
- Make sure the breather pipe is connected after installation.

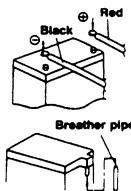

YAMAHA EUB-U419B-00

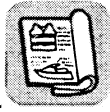

E

Other labels

12

**FIRE EXTINGUISHER  
COMPARTMENT**

13

**RECOMMENDED OIL**  
YAMALUBE 2 STROKE OUTBOARD OIL or an equivalent  
TC-W3 certified outboard oil.  
YAMAHA GAS-U418C-41

14

**AFTER OPERATION**  
After removing from the water:  
• Flush drive system and hull with fresh water. Open the drain plug at the back of the hull.  
• Start the engine and rapidly pull and release the throttle lever for 10-15 seconds to drain any left over water in the exhaust system.  
• Refer to the Owner's Manual for complete maintenance and storage information.  
YAMAHA GAS-U418C-41

15





EJU00296



### SAFETY INFORMATION

When you operate your Yamaha Water Vehicle, you must know and practice the following for your safety:

- Before operating the water vehicle, read this entire manual, the Riding Practice Tips, the Riding Instruction card and all warning labels on the water vehicle. Reading these materials should give you an understanding of the vehicle and its operation.  
Never allow anyone to operate this water vehicle until they too have read this Owner's Manual, the Riding Practice Tips, the Riding Instruction card and all warning labels.

EJU00300

### LIMITATIONS ON WHO MAY OPERATE THE VEHICLE

- This vehicle is recommended only for operators 16 and older with a valid motor vehicle license.  
Even though a motor vehicle operator's license is not required for water vehicle operation in most states, it is one indicator that the operator has previously demonstrated a reasonable degree of maturity, responsibility, and good judgment.  
A responsible adult must supervise operation of this vehicle by minors.  
Many states have minimum age and education requirements. Always check states and all applicable local boating laws that apply to you before you operate the water vehicle.

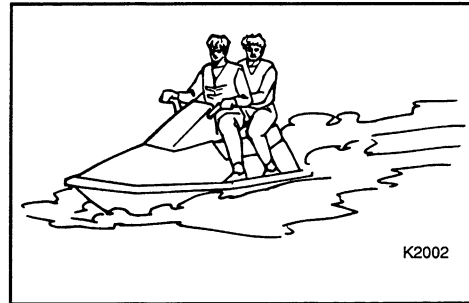

- Your water vehicle is designed to carry the operator and only one passenger, as long as the total weight does not exceed the maximum load capacity.

**ATTENTION:** \_\_\_\_\_

Maximum vehicle load capacity: 160 kg (353 lb)

Includes weight of operator, passenger, and any cargo.

- Do not try to ride with a passenger until you have considerable practice riding alone. Operating with a passenger requires more skill. Take the time to become accustomed to the handling characteristics of the vehicle with a passenger before trying any difficult maneuvers.



E

EJU00306

### CRUISING LIMITATIONS

- Do not jump boat wakes or follow another boat or watercraft too closely. You increase your risk of colliding with another boat, which could result in severe injury or death. Do not jump waves, wakes, or any objects. You risk severe impact injuries. Jumping can also cause damage to the water vehicle.

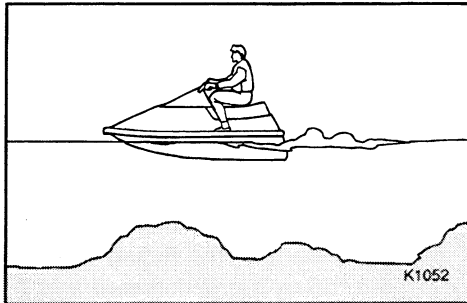
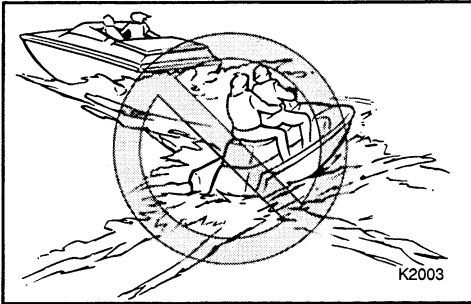

- Do not operate water vehicle after sunset or before dawn. It is not equipped with lighting required for night operation. You risk collision with another boat which could cause injury or death.

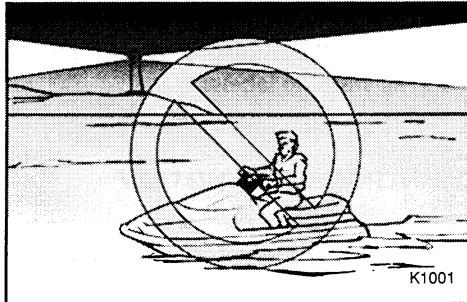

- Do not operate the vehicle in rough water, bad weather or when visibility is poor; this may lead to an accident causing injury or death. Be alert to the possibility of adverse weather. Take note of weather forecasts and the prevailing weather conditions before setting out on your water vehicle.
- As with any water sport, you should not ride your water vehicle without someone else near by. If you ride further than swimming distance from shore, you should be accompanied by another boat or watercraft. It's good, common sense!
- Never ride in water that is less than 60 cm ( 2 feet ) deep. You increase your chance of hitting an underwater obstacle. You could be injured.

EJU00309

### OPERATIONAL REQUIREMENTS

- Operating your water vehicle requires skills acquired only through practice over a period of time. Take the time to learn the basic operating techniques well, before attempting more difficult maneuvers.
- Both operator and a passenger must always wear a U.S. Coast Guard approved personal flotation device (vest-type) because of the drowning hazards associated with water sports.

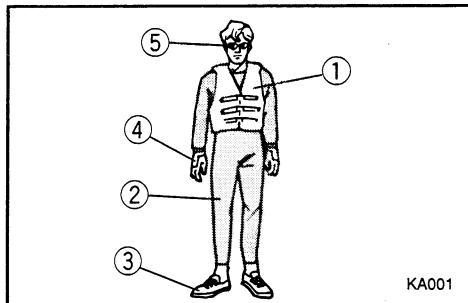

- ① U.S. Coast Guard-approved personal flotation device
- ② Wetsuit
- ③ Water shoes
- ④ Gloves
- ⑤ Eye protection

- Strong streams of water from the jet nozzle, or impact with the water surface can be dangerous. Both operator and a passenger must wear wetsuits. Normal swimming attire may not adequately protect you. A wetsuit will help protect against internal injuries to orifices (rectum and vagina) from strong jet streams, and from impact with the water surface. Wetsuits also help protect against hypothermia (low body temperature) and abrasions.
- Both operator and a passenger should wear water shoes to help protect feet from objects hidden under water. Wearing gloves can also help protect hands from abrasions.

- Wind, water, and glare from the sun may get in your eyes while you operate your water vehicle, reducing your ability to see. You may want to consider wearing eye protection such as sunglasses or goggles while riding. Some may find, however, that eye protection obstructs or distorts their vision, and distracts from operation. Only you know the circumstances in which you operate your water vehicle, so only you can decide if the benefits of eye protection outweigh the potential hazards.

- Helmets meeting Snell or DOT standards are required for IJSBA-sanctioned races. You must decide whether to wear a helmet while you ride recreationally. A helmet could help protect you in certain kinds of accidents. You should also know that a helmet could injure you in some other riding conditions.

A helmet is designed to provide some head protection. Although helmets cannot protect against all foreseeable impacts, a helmet might reduce your injuries in a collision with a boat or other obstacle.

A helmet may have potential safety hazard, as well. A helmet could catch the water during a fall into the water. This is commonly called "bucketing." The resulting strain on your neck could cause choking, severe and permanent neck injuries, or death. A helmet could also increase the risk of an accident if it reduces your vision or hearing, or if it distracts you or increases you fatigue.



How should you decide if a helmet's potential safety benefits outweigh its potential risks for you? Consider your particular riding conditions. Consider factors such as your riding environment and your riding style and ability. Also consider the likelihood of traffic congestion, and the water surface conditions. If you decide to wear a helmet based upon your riding circumstances, choose one carefully. Look for a helmet designed for personal watercraft use, if possible. Consider a helmet meeting Snell or DOT standards. If you will be engaging in closed-course competition, follow the helmet requirements of the sanctioning organization.

- NEVER ride the vehicle after consuming alcohol or taking drugs.

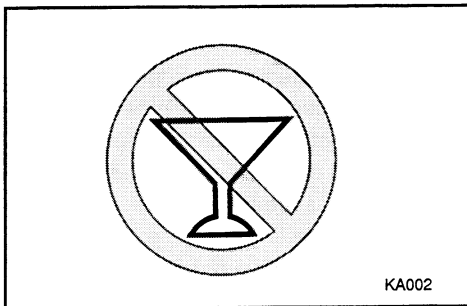

- For reasons of safety and proper care, always perform the pre-operation checks on page 3-3 before riding.
- The operator and a passenger should always keep both feet on the footrest floor when the vehicle is in motion. If you lift your feet, you increase your chances of losing your balance, and your feet could hit objects outside the water vehicle. Do not give a ride to a child whose feet cannot reach the footrest floor.

The passenger should always firmly grasp the operator's waist.

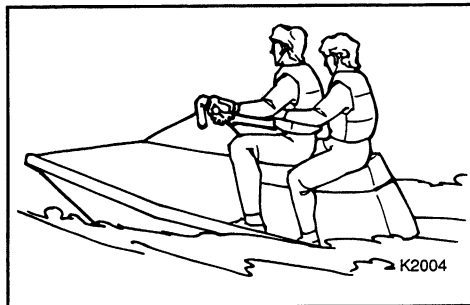

- If you are pregnant or in poor health, ask your doctor's advice on whether it is safe for you to ride this water vehicle.
- Do not attempt to modify this water vehicle!  
Modifications to your machine may reduce safety and reliability, and may make the vehicle unsafe or illegal for use.
- The operator should always attach the engine stop switch lanyard (cable) to his left wrist so that the engine will stop if the operator falls off.  
Be sure the lanyard is not wrapped around the handlebar or tangled in the controls which would prevent the lanyard from pulling away.





- To prevent accidental starting of the engine, always remove the lock-plate from the stop switch when the engine is not running.

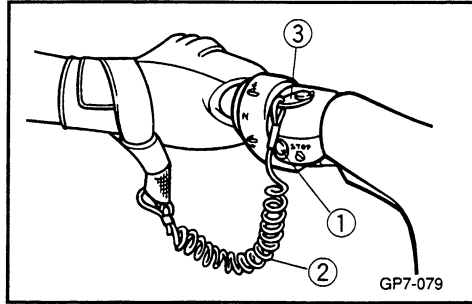

- ① Engine stop switch
- ② Engine stop switch lanyard
- ③ Lock-plate attached to the lanyard

- Always watch carefully for swimmers. Stay away from swimming areas. Swimmers are hard to see and you could accidentally hit someone in the water.
- Avoid being hit by another boat! You should always take the responsibility to watch for traffic, other boaters may not be watching for you. If they don't see you, or you maneuver more quickly than other boaters expect, you risk a collision.  
Maintain a safe distance from other boats or watercraft, and also watch for boat's ski ropes or fishing lines. Obey the "Rules of the Road" (see page 1-13~1-15), and be sure to check behind you before making a turn.

- This water vehicle is included in the Class A inboard boat classification of the U.S. Coast Guard. A water craft of this type **MUST** carry a fire extinguisher of a B-1 classification, with a capacity of two pounds or more when navigating in waters under Coast Guard jurisdiction. In addition, most state and local boating laws also require that the carry a USCG-approved extinguisher wherever it is operated.

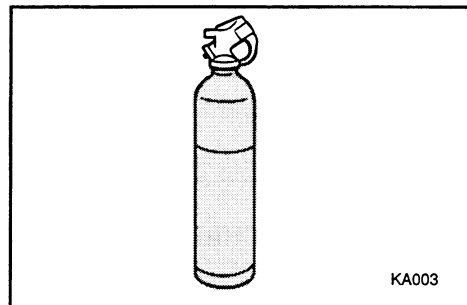



E

EJU00313

### HAZARD INFORMATION

- When transporting or storing your water vehicle, always place the fuel cock in the "OFF" position. Otherwise, it is possible for gasoline to overflow from the carburetor.
- Boats, including your water vehicle, do not have brakes. Release the throttle or stop the engine to slow down. Remember, however, that you have no steering control without throttle.

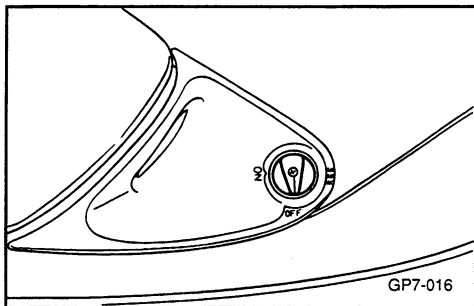

EJU00314

### WATER VEHICLE CHARACTERISTICS

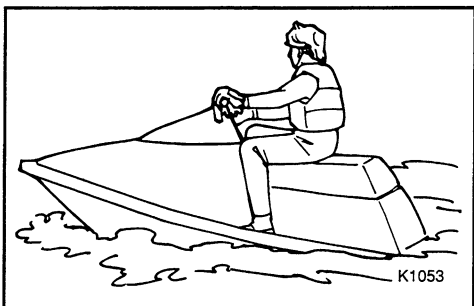

- Jet thrust turns the water vehicle. If you are going faster than trolling speeds (the lowest maneuvering speed), you must use throttle to turn. If you release the throttle completely, you cannot turn-even if you turn the handlebars. Practice turning in an open area without obstructions until you have a good feel for this maneuver.
- Yamaha Water Vehicles are water-jet propelled. The jet pump is directly connected to the engine. This means that jet thrust will produce some vehicle

- movement whenever the engine is running. There is no "neutral" position.
- Keep hands, feet, hair, and all other parts of your body and clothing away from jet intake on the bottom of the hull while engine is running because they could be caught in the intake. Stop the engine and remove the stop switch lock plate before removing any debris or weeds which may have collected around the jet intake. Never insert any object in the jet pump outlet. Severe injury or death could result from coming in contact with the rotating parts of the jet pump.

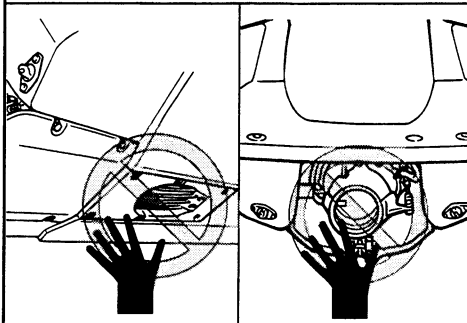
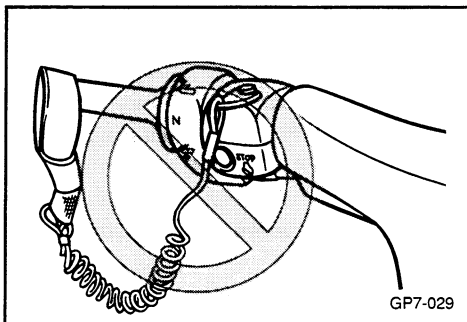



EJU00319

## RULES OF THE ROAD

**Your Yamaha water vehicle is legally considered a power boat. Operation of the water vehicle must be in accordance with the rules and regulations governing the waterway on which it is used.**

Just as there are rules which apply when you are driving on streets and highways, there are waterway rules which apply when you are riding your water vehicle. These rules are used internationally, and are also enforced by the United States Coast Guard and local agencies. You should be aware of these rules, and follow them whenever you encounter another vessel on the water.

Several sets of rules prevail according to geographic location, but are all basically the same as the International Rules of the Road. The rules presented here in your Owner's Manual are condensed, and have been provided for your convenience only. Consult your local U.S. Coast Guard Auxiliary or Department of Motor Vehicles for a complete set of rules governing the waters in which you will be riding your water vehicle.

### **⚠ WARNING**

**Do not operate water vehicle after sunset or before dawn. It is not equipped with lighting required for night operation. You risk collision with another boat which could cause injury or death.**

## STEERING AND SAILING RULES AND SOUND SIGNALS

Whenever two vessels on the water meet one another, one vessel has the right-of-way; it is called the "stand-on" vessel. The vessel which does not have the right-of-way is called the "give-way" or "burdened" vessel. These rules determine which vessel has the right-of-way, and what each vessel should do.

### **Stand-On Vessel**

The vessel with the right-of-way has the duty to continue its course and speed, except to avoid an immediate collision. When you maintain your direction and speed, the other vessel will be able to determine how best to avoid you.

### **Give-Way Vessel**

The vessel which does not have the right-of-way has the duty to take positive and timely action to stay out of the way of the Stand-On vessel. Normally, you should not cross in front of the vessel with the right-of-way. You should slow down or change directions briefly and pass behind the other vessel. You should always move in such a way that the operator of the other vessel can see what you are doing.

### **"The General Prudential Rule"**

This rule is called Rule 2 in the International Rules and says,

'In obeying and construing these rules due regard shall be had to all dangers of navigation and collision, and to any special circumstances, which may render a departure from the above rules necessary in order to avoid immediate danger.'



In other words, follow the standard rules except when a collision will occur unless both vessels try to avoid each other. If that is the case, both vessels become "Give-Way" vessels.

**RULES WHEN ENCOUNTERING VESSELS**

There are three main situations which you may encounter with other vessels which could lead to a collision unless the Steering Rules are followed:

**Meeting** (you are approaching another vessel head-on)

**Crossing** (you are traveling across the other vessel's path)

**Overtaking** (you are passing or being passed by another vessel)

In the following illustration, your water vehicle is in the center. You should give the right-of-way to any vessels shown in the white area (you are the Give-Way vessel). Any vessels in the shaded area must yield to you (they are the Give-Way vessels). Both you and the meeting vessel must alter course to avoid each other.

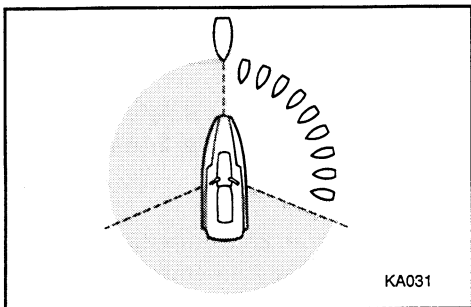

**Meeting**

If you are meeting another power vessel head on, and are close enough to run the risk of collision, neither of you has the right-of-way! Both of you should alter course to avoid an accident. You should keep the other vessel on your port (left) side. This rule doesn't apply if both of you will clear one another if you continue on your set course and speed.

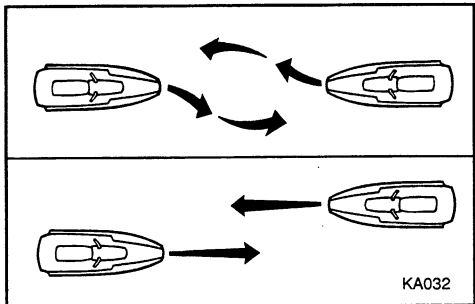

**Crossing**

When two power driven vessels are crossing each other's path close enough to run the risk of collision, the vessel which has the other on the starboard (right) side must keep out of the way of the other. If the other vessel is on your right, you must keep out of its way; you are the Give-Way vessel. If the other vessel is on your port (left) side, remember that you should maintain course and direction, provided the other vessel gives you the right-of-way as it should.

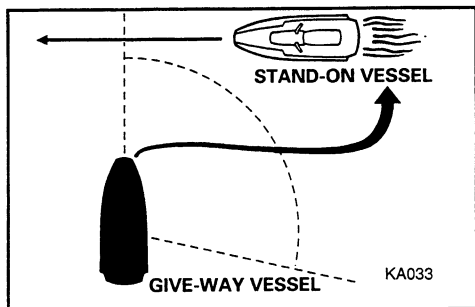



### **Overtaking**

If you are passing another vessel, you are the "Give-Way" vessel. This means that the other vessel is expected to maintain its course and speed. You must stay out of its way until you are clear of it. Likewise, if another vessel is passing you, you should maintain your speed and direction so that the other vessel can steer itself around you.

### **OTHER SPECIAL SITUATIONS**

There are three other rules you should be aware of when riding your water vehicle around other vessels.

#### **Narrow Channels and Bends**

When navigating in narrow channels, you should keep to the right when it is safe and practical to do so. If the operator of a power-driven vessel is preparing to go around a bend that may obstruct the view of other water vessels, the operator should sound a prolonged blast on the whistle (4 to 6 seconds). If another vessel is around the bend, it too should sound the whistle. Even if no reply is heard, however, the vessel should still proceed around the bend with caution. If you navigate such waters with your water vehicle, you will need to carry a portable air horn, available from local marine supply stores.

#### **Fishing Vessel Right-of-Way**

All vessels which are fishing with nets, lines or trawls are considered to be "fishing vessels" under the International Rules. Vessels with trolling lines are not considered fishing vessels. Fishing vessels have the right-of-way regardless of position. Fishing vessels cannot, however, impede the passage of other vessels in narrow channels.

#### **Sailing Vessel Right-of-Way**

Sailing vessels should normally be given the right-of-way. The exceptions to this are:

1. When the sailing vessel is overtaking the power-driven vessel, the power-driven vessel has the right-of-way.
2. Sailing vessels should keep clear of any fishing vessel.
3. In a narrow channel, a sailing vessel should not hamper the safe passage of a power-driven vessel which can navigate only in such a channel.

#### **Reading Buoys and Other Markers**

The waters of the United States are marked for safe navigation by the lateral system of buoyage. Simply put, buoys and markers have an arrangement of shapes, colors, numbers and lights to show which side of the buoy a boater should pass on when navigating in a particular direction. The markings on these buoys are oriented from the perspective of being entered from seaward (the boater is going towards the port). This means that red buoys are passed on the starboard (right) side when proceeding from open water into port, and black buoys are to port (left) side. When navigating out of port, your position with respect to the buoys should be reversed; red buoys should be to port and black buoys to starboard.

Many bodies of water used by boaters are entirely within the boundaries of a particular state. The Uniform State Waterway Marking System has been devised for these waters. This system uses buoys and signs with distinctive shapes and colors



to show regulatory or advisory information. These markers are white with black letters and orange borders. They signify speed zones, restricted areas, danger areas, and general information.

Remember, markings may vary by geographic location. Always consult local boating authorities before riding your water vehicle in unfamiliar waters.

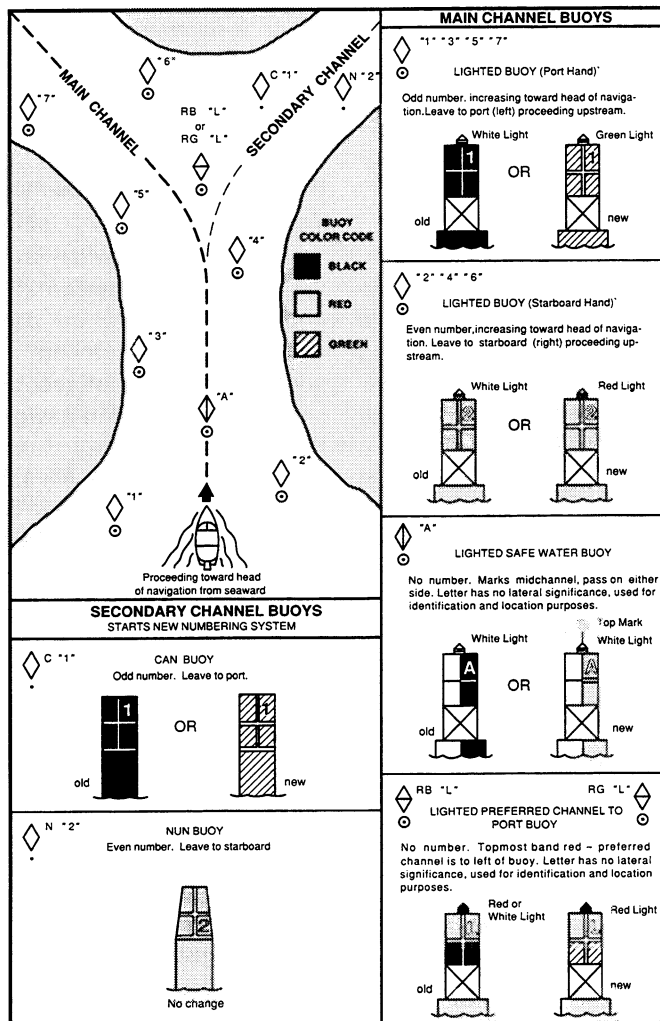



EJU00320

## TO GET MORE BOATING SAFETY INFORMATION

Be informed about boating safety. Additional publications and information can be obtained from many organizations, including the following.

### **United States Coast Guard**

Consumer Affairs Staff (G-BC)  
Office of Boating, Public, and Consumer Affairs  
U.S. Coast Guard Headquarters  
Washington, D.C. 20593-0001  
Boating Safety Hotline: 1-800-368-5647

### **Personal Watercraft Industry Association (PWIA)**

401 N. Michigan Ave.  
Chicago, IL 60611

### **Personal Watercraft Riders Association (PWRA)**

401 N. Michigan Ave.  
Chicago, IL 60611

EJU00322

## ENJOY YOUR WATER VEHICLE RESPONSIBLY

- You share the areas you enjoy when riding your Water Vehicle with others and with nature. So your enjoyment includes a responsibility to treat these other people, and the lands, waters, and wildlife with respect and courtesy.
- Whenever and wherever you ride, think of yourself as the guest of those around you. Remember, for example, that the sound of your Water Vehicle may be music to you, but it could be just noise to others. And the exciting splash of your wake can make waves others won't enjoy. Avoid riding close to shoreline homes and waterfowl nesting areas or other wildlife areas, and keep a respectful distance from fishermen, other boats, swimmers, and populated beaches. When travel in areas like these is unavoidable, ride slowly and obey all laws.
- Remember that pollution can be harmful to the environment. Do not refuel or add oil where a spill could cause damage to nature. Remove your Water Vehicle from the water and move it away from the shoreline before refueling. And keep your surroundings pleasant for the people and wildlife that share the waterways: don't litter!
- When you ride responsibly, with respect and courtesy for others, you help ensure that our waterways stay open for the enjoyment of a variety of recreational opportunities.



E

EJU00323

## FUEL REQUIREMENTS GASOLINE(PETROL)

Recommended gasoline:  
Unleaded regular gasoline  
Minimum octane rating:  
86 (Pump octane number): (R+M)/2  
90 (Research octane number)

### **⚠ WARNING**

**GASOLINE (PETROL) AND ITS VAPORS ARE HIGHLY FLAMMABLE AND EXPLOSIVE!**

- Do not smoke when refueling, and keep away from sparks, flames, or other sources of ignition.
- Stop engine before refueling.
- Refuel in a well-ventilated area. Do not stand or sit on the water vehicle while refueling in case of fire.
- Take care not to spill gasoline (petrol). If gasoline (petrol) spills, wipe it up immediately with dry rags. Always properly dispose of gasoline-soaked rags.
- Avoid overfilling the fuel tank. Stop filling when the fuel level just reaches the bottom of the filler tube. Do not fill up the filler tube because fuel expands as it warms up and could overflow.
- Tighten the filler cap securely after refueling.
- If you should swallow some gasoline (petrol), inhale a lot of gasoline (petrol) vapor, or get gasoline (petrol) in your eyes, get immediate medical attention.
- If any gasoline (petrol) spills onto your skin, immediately wash with soap and water. Change clothing if gasoline (petrol) spills on it.

### **CAUTION:**

Use only fresh gasoline (petrol) that has been stored in clean containers.

### **Gasohol**

There are two types of gasohol: gasohol containing ethanol and that containing methanol. Gasohol containing ethanol can be used if ethanol content does not exceed 10% and the fuel meets minimum octane ratings. Gasohol containing methanol is not recommended by Yamaha because it can cause fuel system damage or engine performance problems.

EJU00324

### **ENGINE OIL**

Recommended oil: YAMALUBE 2 STROKE OUTBOARD OIL  
If YAMALUBE 2 STROKE OUTBOARD OIL is not available, another 2-stroke engine oil with a BIA-certified TC-W3 rating may be used.





EJU00326

## Chapter 2 FEATURES AND FUNCTIONS

LOCATION OF MAIN  
COMPONENTS.....2-1

2

OPERATION OF CONTROLS  
AND OTHER FUNCTIONS .....2-4

Front seat .....2-4

Rear seat .....2-4

Engine hood .....2-5

Fuel tank filler cap .....2-6

Fuel cock .....2-6

Engine stop switches.....2-7

Choke knob .....2-8

Throttle lever .....2-8

Starter switch .....2-8

Cooling water pilot outlet.....2-9

Steering.....2-9

Quick shift trim system  
(Q.S.T.S.) .....2-10

Overheat warning system.....2-11

Handgrips .....2-12

Bow eye, Rope holes, and Cleat.....2-12

Multifunction meter .....2-13

Storage compartment .....2-22

YAMAHA adjustable sponson .....2-23



E

EJU00327

## LOCATION OF MAIN COMPONENTS

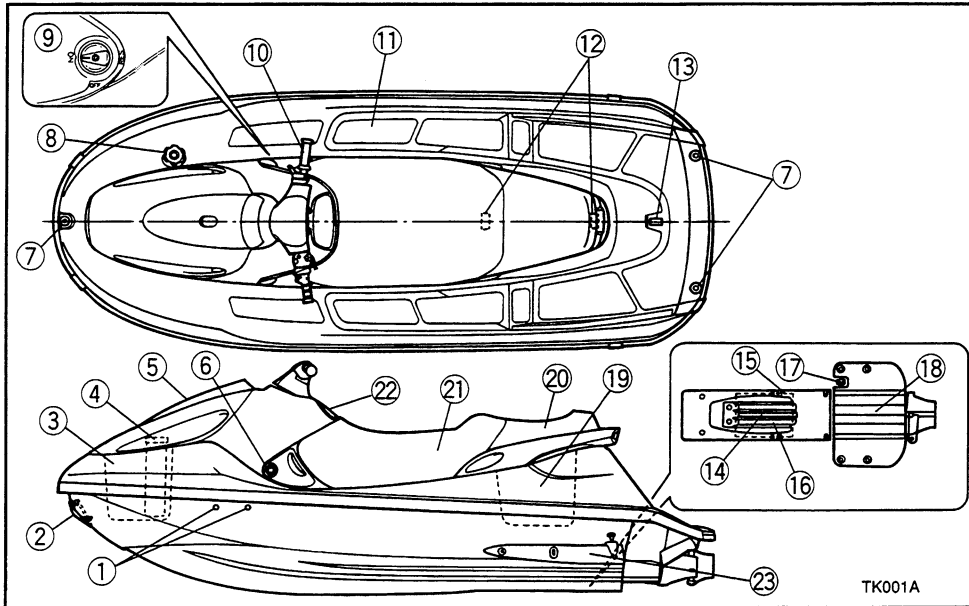

TK001A

- |  |   |
|--|---|
| <p>① <b>Cooling water pilot outlet</b><br/>Check point of cooling water flowing</p> <p>② <b>Bow eye</b><br/>Rope attachment point for transporting, mooring or towing the water vehicle in an emergency</p> <p>③ <b>Front storage compartment</b></p> <p>④ <b>Fire extinguisher compartment</b></p> <p>⑤ <b>Front hood</b></p> <p>⑥ <b>Choke knob</b><br/>Pull knob when starting a cold engine</p> <p>⑦ <b>Rope hole</b><br/>Rope attachment point for transporting, mooring</p> <p>⑧ <b>Fuel tank filler cap</b><br/>Unscrew counterclockwise to add fuel. Tighten securely clockwise.</p> <p>⑨ <b>Fuel cock</b><br/>Select fuel flow from normal or reserve area of the fuel tank, or shut off fuel flow.</p> <p>⑩ <b>Handle bars</b><br/>Control steering direction</p> <p>⑪ <b>Footrest floor</b><br/>To place feet for balance</p> | <p>⑫ <b>Seat latch</b><br/>Locking and releasing the seat lock</p> <p>⑬ <b>Cleat</b><br/>Rope attachment point for mooring only</p> <p>⑭ <b>Drive shaft</b><br/>Transmits power from engine to the jet pump</p> <p>⑮ <b>Jet intake (Water intake)</b><br/>Water intake source for jet thrust and engine cooling water</p> <p>⑯ <b>Intake grille</b><br/>Prevents debris from getting into the jet pump</p> <p>⑰ <b>Speed sensor</b></p> <p>⑱ <b>Jet pump cover</b></p> <p>⑲ <b>Seat storage compartment</b></p> <p>⑳ <b>Rear seat</b></p> <p>㉑ <b>Front seat</b></p> <p>㉒ <b>Storage compartment</b></p> <p>㉓ <b>Yamaha Adjustable Sponson (Y.A.S.)</b><br/>Changes maneuvering characteristic by adjusting the sponson angle</p> |
|--|---|

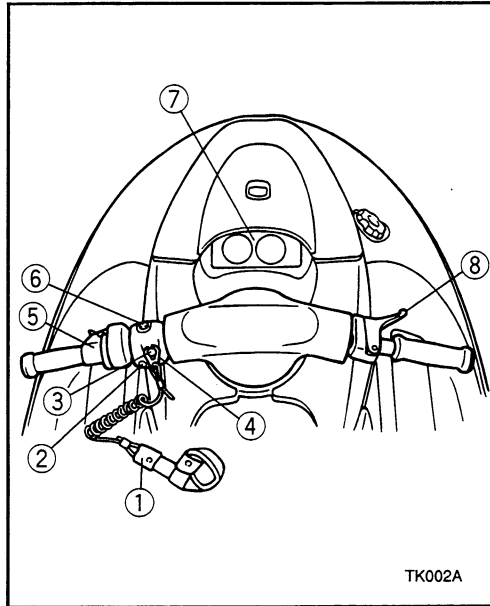

TK002A

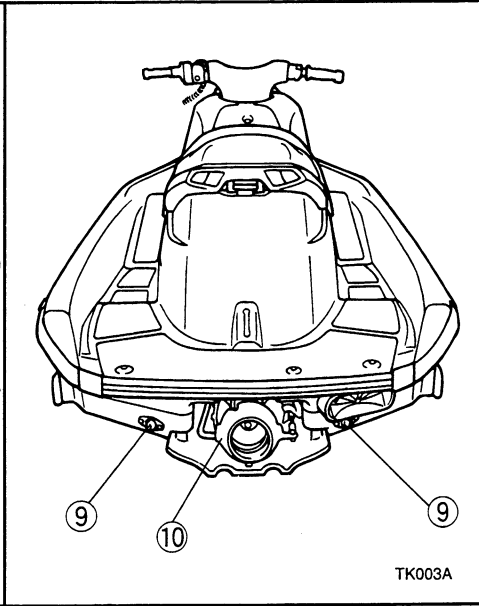

TK003A

- ① **Engine stop switch lanyard (Cable)**  
By connecting to the stop switch and operator will stop the engine if the operator falls off the vehicle
- ② **Engine stop switch**  
Depress to stop the engine
- ③ **Engine stop lanyard switch**  
Removing the rock plate makes to stop the engine and disable to start the engine.
- ④ **Lock plate**  
Insert the lock plate in the stop switch to allow the engine to be started. Remove the plate to stop the engine or prevent it from starting.
- ⑤ **Quick Shift Trim System controller**  
Controls thrust trim for different operating conditions
- ⑥ **Starter switch**  
Depress to start the engine
- ⑦ **Multifunction meter**  
Shows engine speed and vehicle speed and some other conditions on the vehicle
- ⑧ **Throttle lever**  
Controls the engine speed when accelerating and decelerate
- ⑨ **Drain plugs**  
Open to drain water in the bilge when the vehicle is on dry land. Tighten securely before launching craft.
- ⑩ **Jet nozzle**  
Changes the direction of jet thrust according to handlebar position to steer the vehicle



E

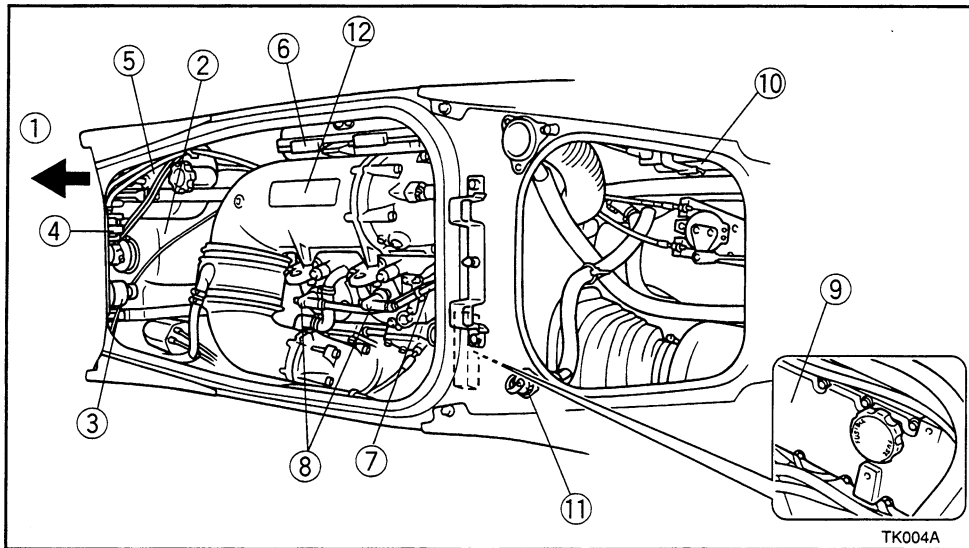

- ① **Bow (Front)**
- ② **Fuel tank**
- ③ **Water separator**  
To trap water from the air passage to the fuel tank
- ④ **Fuel filter**  
Prevents dust contained in fuel from getting into the engine
- ⑤ **Oil tank**
- ⑥ **Silencer cover**  
To help prevent water from getting into the engine and reduce the air intake noise
- ⑦ **High tension cord**  
Deliver electrical current to the spark plug
- ⑧ **Spark plug**  
To ignite to air and fuel mixture in the cylinder
- ⑨ **Electrical box**  
Contains most electrical components, included fuse in this water resistant box
- ⑩ **Battery**
- ⑪ **Flush hose connector**
- ⑫ **Muffler box**



EJU00328

### OPERATION OF CONTROLS AND OTHER FUNCTIONS

EJU00334

#### FRONT SEAT

There is a seat latch under the rear seat. First remove the rear seat to reach the front seat latch lever, then remove the front seat.

#### Removal

Pull the front seat latch lever up, then lift the rear of the seat, and pull back.

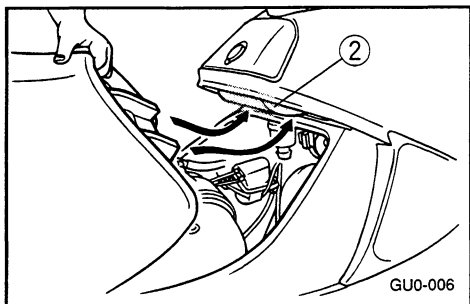
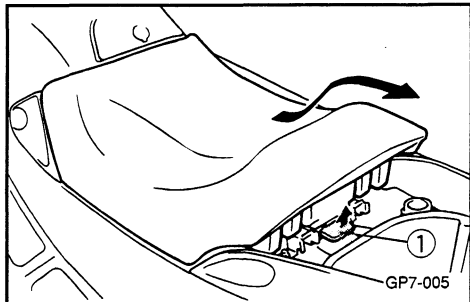

① Front seat latch lever

#### Installation

Position the seat on the deck so the front projection of the seat fits under the stay on the deck. Then push the rear of the seat down until the seat locks latch.

② Stay

**NOTE:** \_\_\_\_\_  
Make sure the seat is firmly secured before riding.  
\_\_\_\_\_

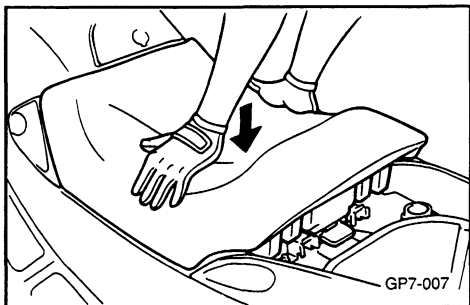

EJU00335

#### REAR SEAT

There is a seat latch lever at the rear of the seat to remove the rear seat.

#### Removal

Pull the rear seat latch lever up, then lift the rear of the seat and pull back.

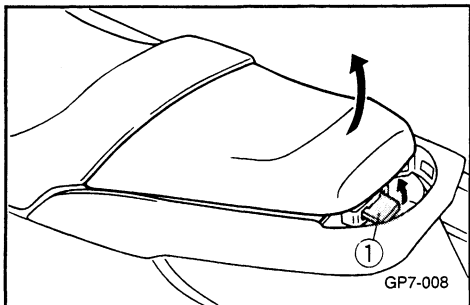

① Rear seat latch lever



**E**

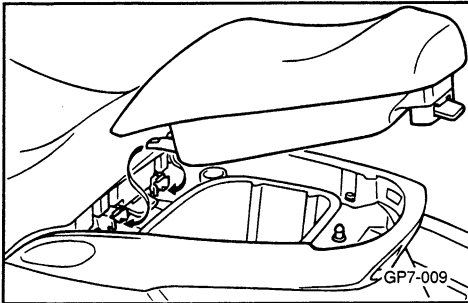

### Installation

Position the seat on the deck so the front projections on the underside of the seat fits into the stays on the deck. Then push the rear of the seat down until the seat lock latches.

### NOTE:

Make sure the seat is firmly secured before riding.

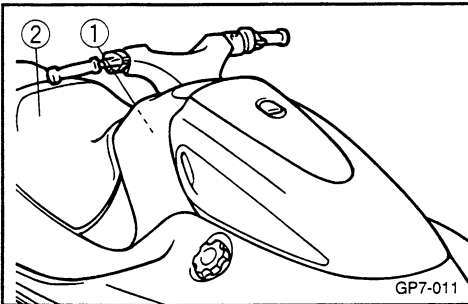
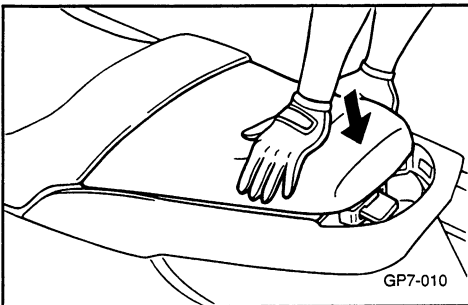

EJU00343

### ENGINE HOOD

The engine hood is fixed on the deck. To access the engine compartment, remove the seats and lift out the front storage compartment. Refer to "FRONT SEAT" and "STORAGE COMPARTMENT" for their opening and removal.

- ① Engine hood
- ② Front seat
- ③ Front storage compartment

### NOTE:

Make sure the engine compartment is firmly secured by all the seats and front storage compartment before riding.

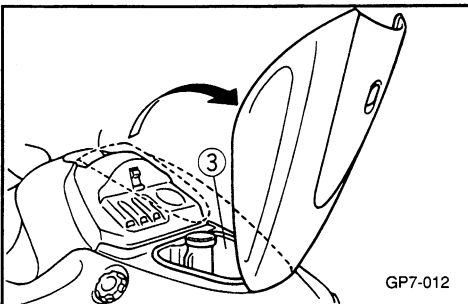



E

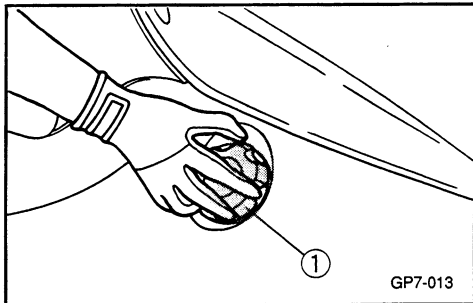

EJU00345

### FUEL TANK FILLER CAP

To remove the fuel tank filler cap, turn it counterclockwise.

① Fuel tank filler cap

Be sure to tighten the cap securely before riding.

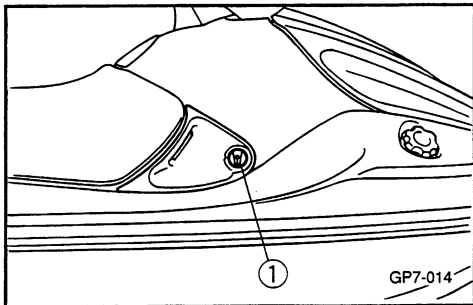

EJU00348

### FUEL COCK

The fuel cock supplies fuel from the tank to the carburetor.

The fuel cock has three positions;

① Fuel cock

#### OFF

With the knob in this position, fuel does not flow. Always turn the knob to this position when the engine is not running.

#### ON

With the knob in this position, fuel flows to the carburetor. Normal running is done with the knob in this position.

#### RESERVE

This position selects "RESERVE". If you run out of fuel in the "ON" position, turn the knob to this position to be able to continue for a short time. Remember to **FILL THE TANK AT THE FIRST OPPORTUNITY**. After refueling, return the fuel cock knob to the "ON" position for further riding.

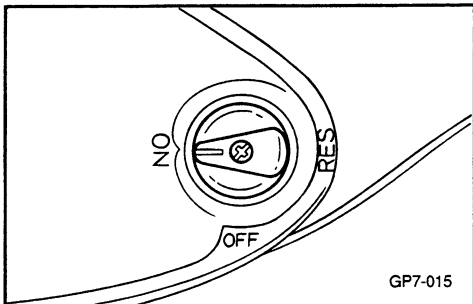



EJU00349

### ENGINE STOP SWITCHES

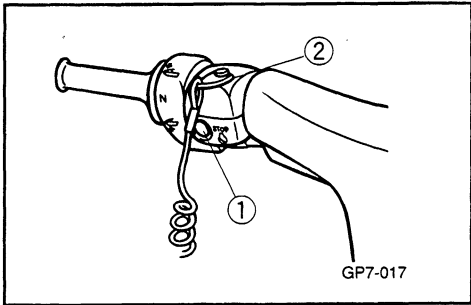

These switches have the following functions: one is to stop the engine normally by pressing button ① on the switch box; the other is to stop the engine if you fall off, or in case of an emergency, when lock-plate ② attached to the lanyard is pulled from the switch.

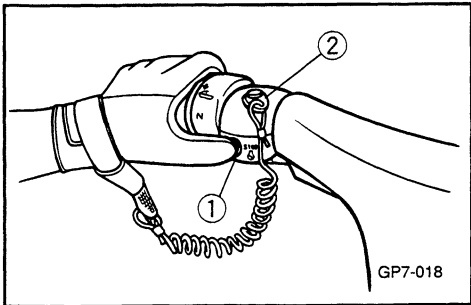

- ① Engine stop switch
- ② Lock-plate

When the button on the switch is pushed, without removing the lock-plate, the ignition circuit opens and stops the engine immediately.

**⚠ WARNING**

You need engine power to turn. Shutting off the engine can cause you to hit an obstacle you are attempting to avoid. A collision could result severe injury or death.

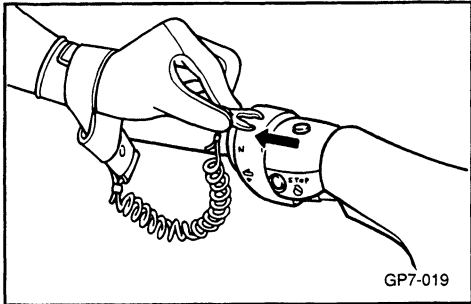

Should the lock-plate be removed for any reason, the engine stops by itself.

**⚠ WARNING**

- Always attach the engine stop switch lanyard (cable) to your left wrist **BEFORE** starting the engine.
- To prevent accidental starting of the engine, always remove the lock-plate from the stop switch when the engine is not running.





E

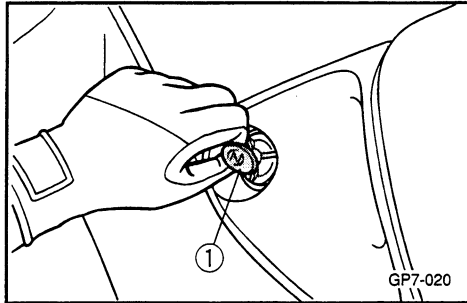

EJU00350

### CHOKE KNOB

Pulling this knob supplies a rich fuel-air mixture required to start the engine.

**NOTE:** \_\_\_\_\_

Refer to Starting the engine on page 3-12 to 3-14 for proper operation.

① Choke knob

EJU00351

### THROTTLE LEVER

Moving the throttle lever toward the handlebar increases engine speed. When the throttle lever is released, it returns to its closed (idle) position through the action of a return spring.

**⚠WARNING** \_\_\_\_\_

Before starting the engine, always check the operation of the throttle lever. It should move smoothly through its full range of operation, and should spring back to the idle position when released.

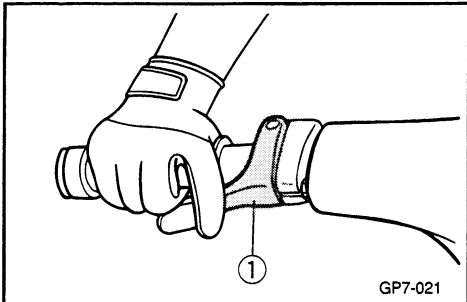

① Throttle lever

EJU00353

### STARTER SWITCH

To start the engine, push the green button on the starter switch.

**NOTE:** \_\_\_\_\_

- The engine will not start when the lock plate is removed from the engine stop switch. The starter motor will not turn.
- The engine will not start if the "LOCK" mode has been chosen. To set the mode to "START", refer to the "PAD-LOC" function in the "MULTIFUNCTION METER" instructions.

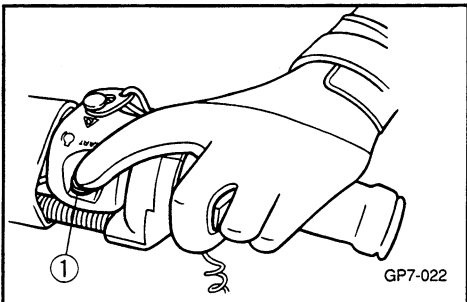

① Starter switch



E

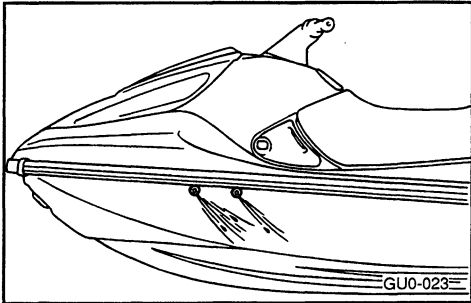

EJU00354

### COOLING WATER PILOT OUTLET

This engine is equipped with a cooling-water pilot outlet at left side of the hull. Check that water comes out of the outlet while the engine is running, particularly while applying throttle. If you do not see any water at the outlet, cooling water may not be circulating in the engine.

In that case, stop the engine and check for the cause (Refer to overheat warning system).

### NOTE:

If water cooling passages on the engine are dry it will take about 20 seconds to reach water at the outlet after starting.

EJU00356

### STEERING

Your water vehicle can be steered by turning the handlebars the same direction you wish to travel, to the right or left. When the handlebars are turned, the angle of the jet (output) nozzle at the rear of the craft is changed, and the change in direction of the nozzle changes the direction of the vehicle accordingly. Therefore, because only the strength of the jet-flow output can determine the speed and direction of a turn, the throttle must always be opened above idle when attempting a turn, except at trolling speed.

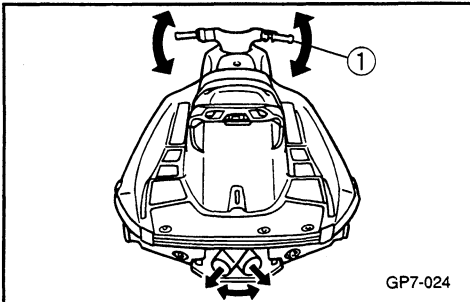

① Handlebars



E

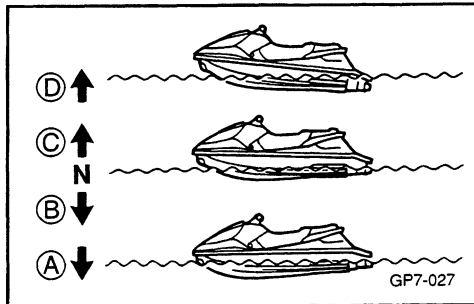
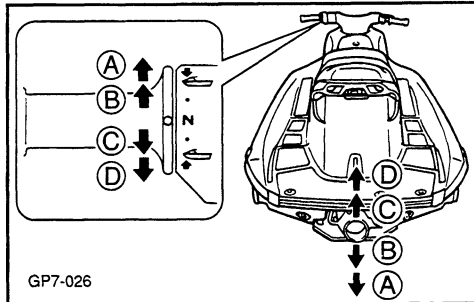
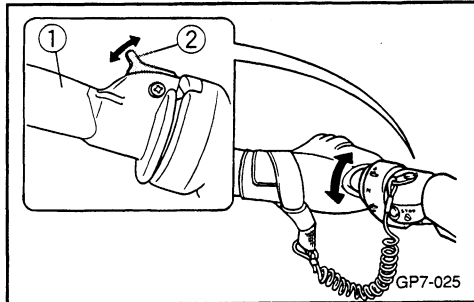

EJU00360

### QUICK SHIFT TRIM SYSTEM (Q.S.T.S.)

The trim angle of your water vehicle can be adjusted by operating the Q.S.T.S. Operating the trim shifting grip of the Q.S.T.S. changes the angle of the jet (output) nozzle at the rear of the craft. The nozzle angle changes the trim angle of the vehicle to one of five positions : two positions A and B for bow down, neutral "N", and two positions C and D for bow up.

- ① Trim shifting grip
- ② Shift lock release lever

#### To change the trim angle of the vehicle

- 1) Set the throttle lever to half open (3000 r/min) or less.
- 2) Squeeze and hold the shift lock release lever. Then turn the trim shifting grip to the desired position.
  - Turning the grip to A or B from "N":  
Bow will go down while the vehicle is on plane.
  - Turning the grip to C or D from "N":  
Bow will go up while the vehicle is on plane.
- 3) Release the shift lock release lever to lock the position.

#### CAUTION:

Do not turn the grip while operating the vehicle at full throttle, otherwise damage could occur to the Q.S.T.S.

The Neutral ("N") shift position will provide good performance for most conditions. To enhance particular types of performance, choose the one of the "Bow Down" or "Bow Up" positions.



E

### Shifting to “Bow Down”

“Bow Down” puts more of the bow in the water. This gives the water vehicle more “hook,” which enhances turning performance. This position will also help the water vehicle get up on plane more quickly. At higher speeds, however, the water vehicle will have greater tendency to “bow steer” and follow waves and wakes in the water. Fuel economy and maximum speed are also reduced.

### Shifting to “Bow Up”

“Bow Up” puts less of the bow in the water. There is less water resistance, so straight-ahead acceleration when on plane and top speed are enhanced. In some conditions, however, the vehicle may tend to “porpoise” (hop in the water). If the vehicle is porpoising, choose Neutral or Bow Down trim.

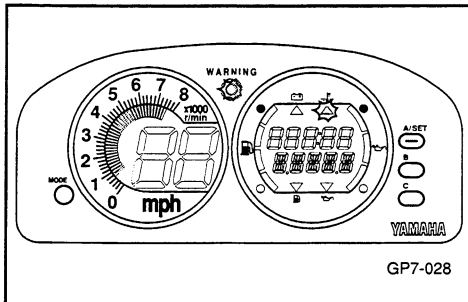

EJU00366

### OVERHEAT WARNING SYSTEM

The engine has an overheat warning device. If the engine starts to overheat, the overheat warning symbol/indicator begins to blink, the buzzer sounds, and the engine speed will be limited to about 3,000 r/min.

If this happens, check for water discharge at the cooling water pilot outlet. If there is no discharge of water, beach the vehicle and check for clogging at the jet intake and impeller.

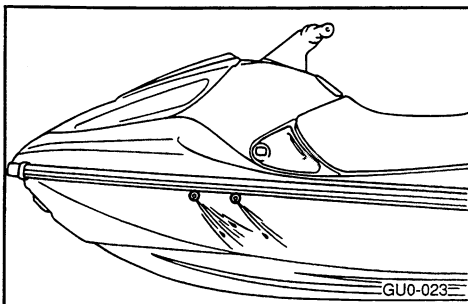



E

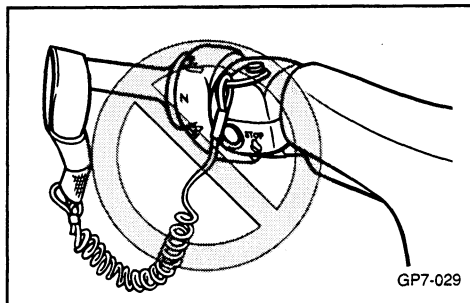

**WARNING**

Before attempting to remove weeds or debris from the jet intake or impeller areas, shut off the engine and remove the engine stop switch lock-plate from the stop switch. Severe injury or death could result from coming in contact with the rotating parts of the jet pump.

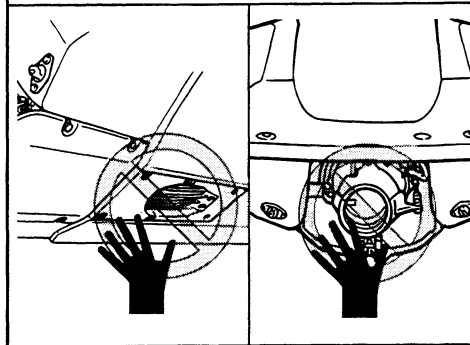

**CAUTION:**

If you cannot locate and correct the cause of the overheating, consult a Yamaha dealer. Continuing to operate at higher speeds could result in severe engine damage.

**NOTE:**

The buzzer will stop sounding if any button on the multifunction meter is pressed.

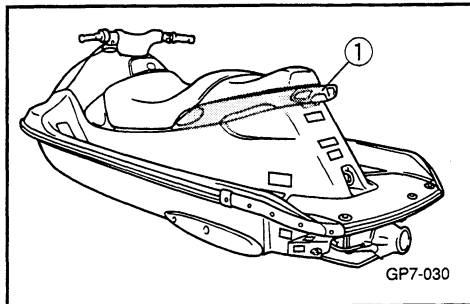

EJU00367

**HANDGRIPS**

Handgrips provide a handhold to use while boarding the vehicle.

- ① Handgrips

**CAUTION:**

Do not use to tow objects, lift vehicle, or attach tie downs. Damage could occur.

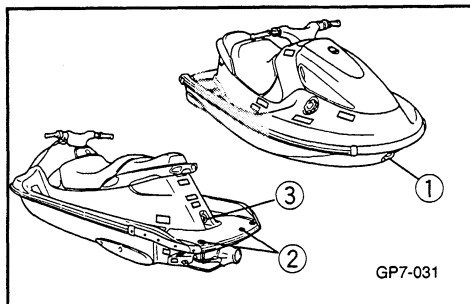

EJU00368

**BOW EYE, ROPE HOLES, AND CLEAT**

The bow eye, rope holes, and cleat are designed for mooring the vehicle and for securing it to the trailer.

- ① Bow eye
- ② Rope holes
- ③ Cleat

**CAUTION:**

Cleat is for mooring only. Do not use cleat to lift vehicle. Damage could occur.



E

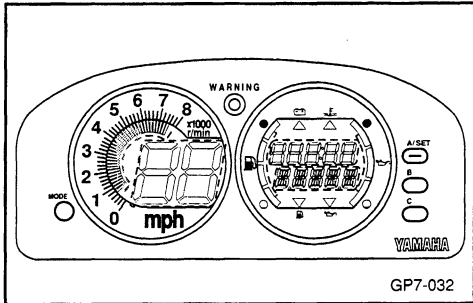

EJU00376

### MULTIFUNCTION METER

This meter contains following functions for the help and convenience of operation.

- ① "MODE" button
- ② "SET" button
- ③ "CODE" setting buttons
- ④ Tachometer
- ⑤ Speedometer
- ⑥ Fuel level meter
- ⑦ Engine oil level meter
- ⑧ Display for Clock, Hour meter, Trip meter and Stop watch
- ⑨ Warning indicator lamp
- ⑩ Display for PADLOC and direction of warning indicator
- ⑪ Warning indicators

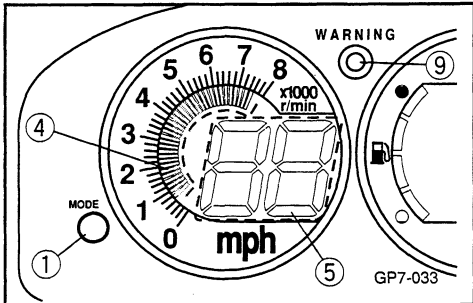

### CAUTION:

- On land, do not attempt to run the engine at full throttle or for more than 15 seconds to check the operation of this meter. Otherwise the engine could overheat.
- Use the specified resistor-type spark plug and cap, otherwise the meter may function erratically.

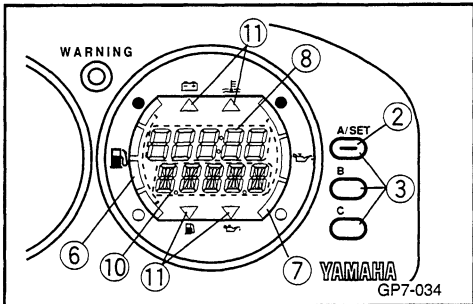

EJU00377

### PADLOC (Programmable digital locking ignition)

This feature is provided to help prevent unauthorized use or theft of the vehicle. The function allows you to chose either "START" or "LOCK" mode, as the situation requires, much as you would use a main switch key in a motor vehicle.



E

- NOTE:**
- If the initial setting of PADLOC has not been done, the "START" mode is automatically selected.
  - If you have previously chosen "LOCK" mode, the engine will not start unless the right code is put in to select "START" mode.

**Initial setting**

- 1) Disconnect the blue connector ① behind the front storage compartment.

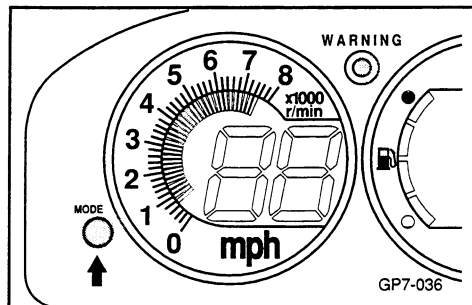
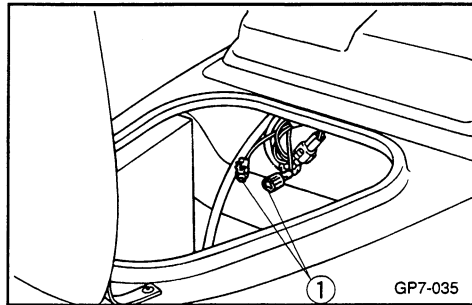

- 2) After the warning indicator lamp lights, press the "MODE" button for at least 3 seconds until the display appears as shown in illustration (A). You are ready to set your code.
- 3) Select your 4-letter code by pressing the "A/SET", "B" or "C" buttons in a desired sequence.

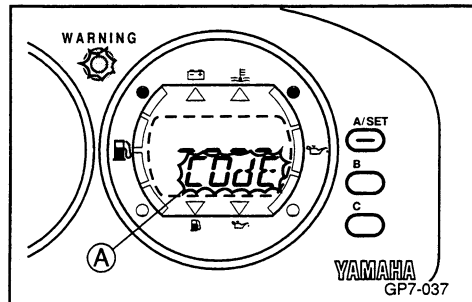

- NOTE:**
- If you do not press a button for more than 10 seconds, the display automatically turns off. This cancels the process of setting of a code.



E

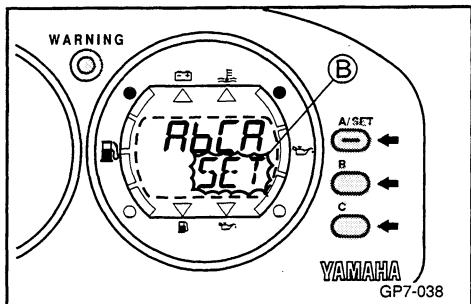

- 4) After completing code setting, the display appears as shown in illustration ②. Then the buzzer will sound 3 times and the display will show "SET". Lastly, the display turns off and the warning indicator lamp turns on again. After the meter has displayed this sequence, reconnect the connector ①.

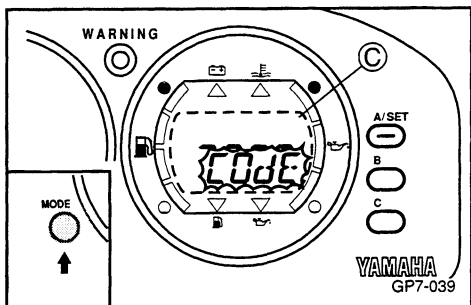

**NOTE:** \_\_\_\_\_  
If you forget your own code, or if you want to change the code, do this "Initial setting" procedure again from the beginning.

● **Selecting "START" or "LOCK" mode**

Selecting the desired mode can only be done after the "Initial setting" has been done and while the display is not lighting.

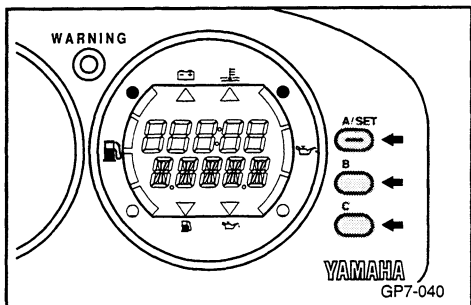

- 1) Press "MODE" button for at least 3 seconds until the display appears as shown in illustration ③. You are ready to enter your code.
- 2) Enter your 4-letter code by pressing the "A/SET", "B" or "C" buttons in the right sequence.

**NOTE:** \_\_\_\_\_  
If you do not press a button for more than 10 seconds, the display automatically turns off. This cancels the process of selecting the mode.

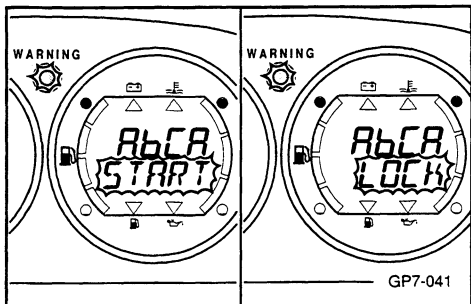

- 3) If the code entered is correct, the mode will change from the previous mode to either "START" or "LOCK". Then the mode display and buzzer will operate for 2 seconds.
  - "START" mode : engine can be started.
  - "LOCK" mode : engine cannot be started.





E

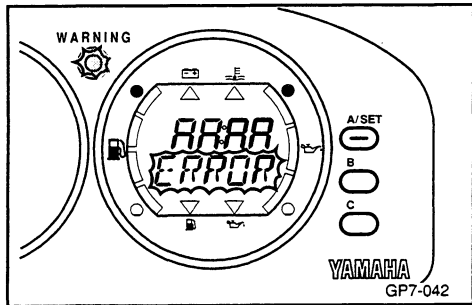

- NOTE:**
- Once you select a mode, the mode will not be changed unless you perform this mode selection again.
  - If the wrong code has been put in, the mode display shows "ERROR" for 2 seconds and the buzzer will sound 5 times. Then the display turns back to ©.
  - If the battery terminals are disconnected after "Initial setting" has been done, the mode is set automatically to the "LOCK" mode.

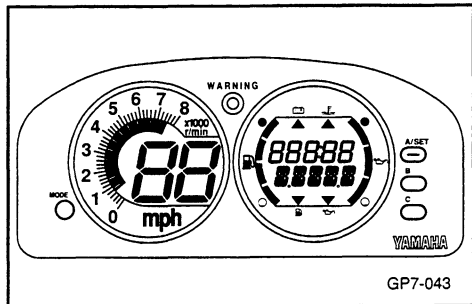

EJU00381

**Operation of multifunction meter**

After starting the engine, demonstration mode display starts showing, then all displays light up and the buzzer sound twice. After few seconds, the meter will operate normally. After stopping the engine, in normal operation, current displays will operate for another 30 seconds.

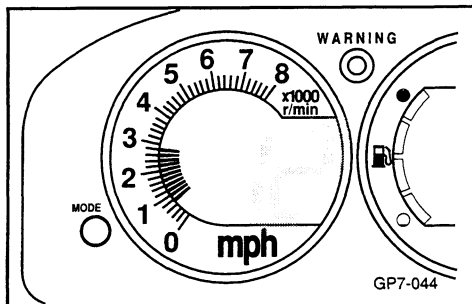

EJU00383

**Tachometer**

The engine speed (r/min) is displayed by segments. Each segment indicates a 200 r/min increment.



E

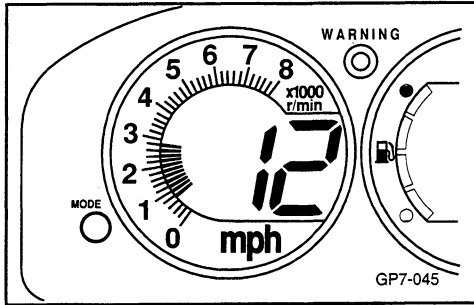

EJU00384

**Speedometer**

The meter shows the vehicle speed in miles per hour (mph).

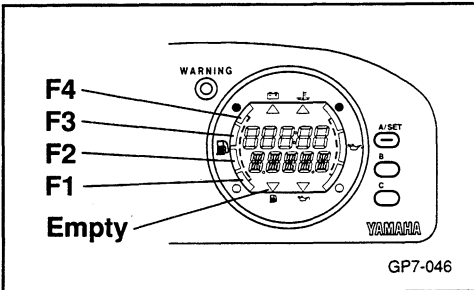

EJU00386

**Fuel level meter**

The fuel level meter is provided for convenient fuel level checking while riding. The fuel level meter has four segments which show the amount of fuel remaining in the fuel tank.

Display		Capacity:L(US gal, Imp gal)	
F4		ON	more than 46 (12.1,10.1)
F3		ON	37~46 (9.8,8.1)~(12.1,10.1)
F2		ON	30~37 (7.9,6.6)~(9.8,8.1)
F1		ON	12~30 (3.2,2.6)~(7.9,6.6)
Empty		Blinking	0~12 (3.2,2.6)

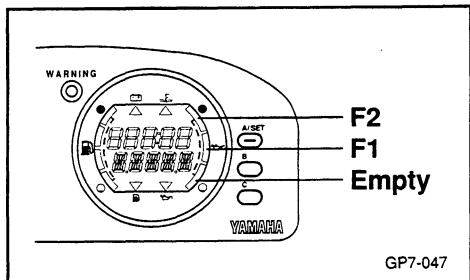

EJU00387

**Engine oil level meter**

The engine oil level meter is provided for convenient oil level checking while riding. The engine oil level meter has three segments which show the amount of oil remaining in the oil tank.

	Display		Capacity:L(US gal, Imp gal)
F2		ON	more than 2.7 (0.71,0.59)
F1		ON	1.2~2.7 (0.31,0.26)~(0.71,0.59)
Empty		ON	0~1.2 (0.31,0.26)

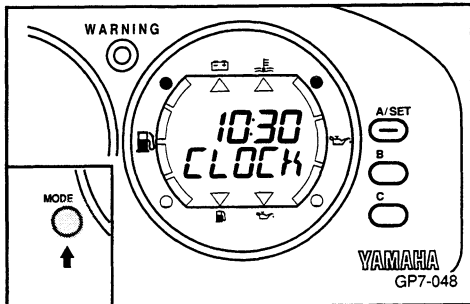

EJU00388

**Clock**

A 12-hour clock is provided in this meter. To show the clock, press the "MODE" button until the display shows "CLOCK".

● **Setting the time**

- 1) When the display shows "CLOCK", press the mode button for at least 3 seconds.
- 2) The buzzer will sound once. The display of hour unit and "SET" start blinking. Then press the "A/SET" button until desired hour is displayed.
- 3) Press "MODE" button again.
- 4) The buzzer will sound once. The display of minute unit and "SET" start blinking. Then press the "A/SET" button until desired minute is displayed.
- 5) Press "MODE" button again.

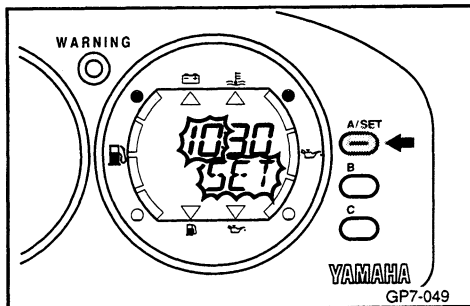



- The buzzer will sound twice. The warning indicator lamp and "SET" blinks for 2 seconds. Then the display turns to "CLOCK" and shows the time.

**NOTE:** \_\_\_\_\_

After the battery terminal is disconnected, clock will be reset.

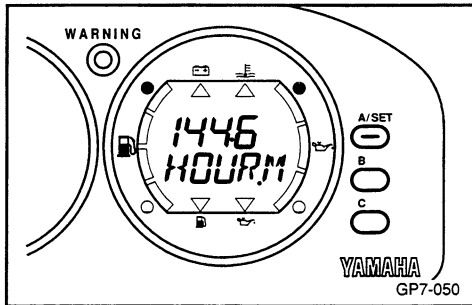

EJU00390

**Hour meter**

The hour meter is provided to make it easy to follow the maintenance schedule. The meter shows the hours of engine operation that have elapsed since the vehicle was new. To show the hour meter, press the "MODE" button until the display shows "HOUR.M".

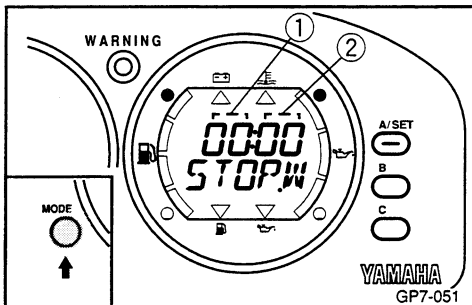

EJU00391

**Stop watch**

Stop watch mode is provided for counting the time. To show the stop watch, press the "MODE" button until the display shows "STOP.W".

- ① Minute unit
- ② Second unit

**• Operation**

- When the display shows "STOP.W", press the "A/SET" button to start counting. The buzzer will sound once.
- Press the "A/SET" button again to stop counting. The buzzer will sound once.
- Press "MODE" button for at least 2 seconds to reset the counted time. The buzzer will sound twice. The display of time and "STOP.W" blinks for 2 seconds. Now it is ready to start counting.

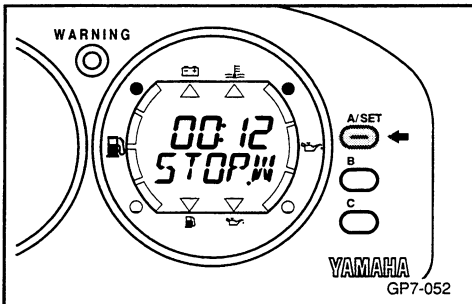



E

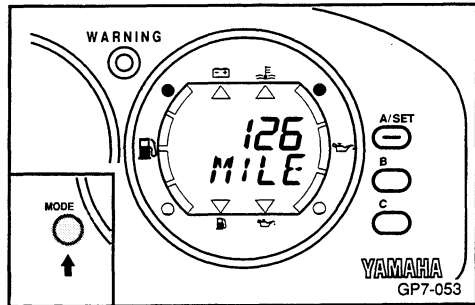

EJU00392

### Trip meter

Trip meter is provided for counting the traveled distance in mile approximately. To show the trip meter, press the "MODE" button until the display shows "TRIP". After showing "TRIP", the display turns to "MILE".

- 1) When the display shows "MILE", press the "MODE" button for at least 2 seconds.
- 2) The buzzer will sound twice. The warning indicator lamp and "MILE" blinks for 2 second, and "000" is displayed. Now the meter started to count the distance you will travel.

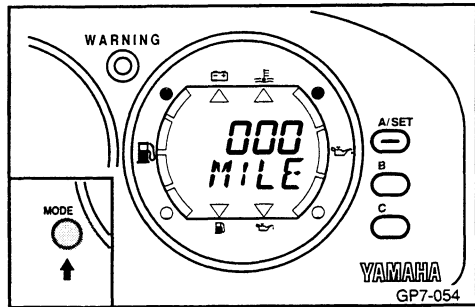

### NOTE:

- After the battery terminal is disconnected, counted distance will be reset.
- Counted distance may vary depending on the water surface conditions, and wind direction. The counted distance should be used for a reference.

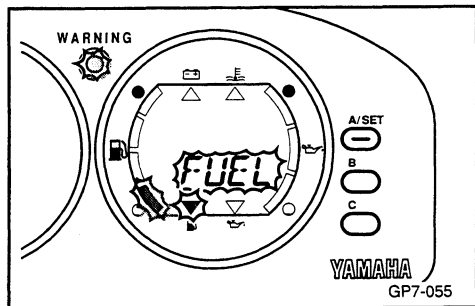

EJU00398

### Warning indicators

#### • Fuel level

If the fuel remaining in the tank drops to about 12 L (3.2 US gal, 2.6 Imp gal), the fuel level segment, the fuel warning indicator, "FUEL" and the warning indicator lamp begin to blink. The buzzer also starts sounding. Turn the fuel cock knob to the "RES" position, then refill with gasoline (petrol) as soon as possible.



E

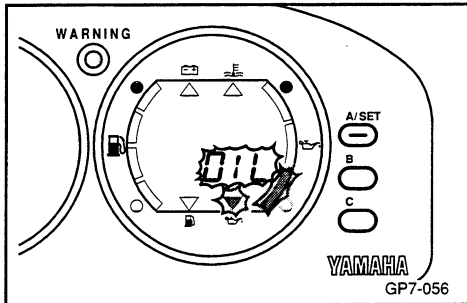

● **Oil level**

If the oil remaining in the tank drops to about 1.2 L (0.31 US gal, 0.26 Imp gal) or the oil filter is clogged, the oil level segment, the oil warning indicator, "OIL" and the warning indicator lamp begin to blink. The buzzer also starts sounding.

**CAUTION:**

- If the oil level warning indicator begins to blink, refill with engine oil as soon as possible.
- If the warning indicator blinks with adequate oil in the tank, check for a clogged oil filter.

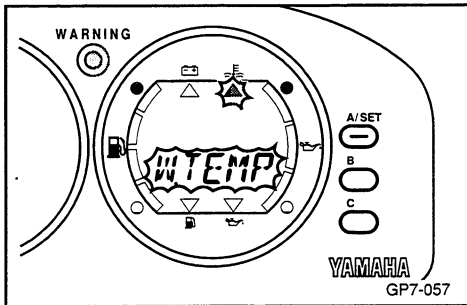

● **Overheat**

If the engine starts to overheat, the overheat warning indicator, "W.TEMP" and the warning indicator lamp begin to blink. The buzzer also starts sounding. Refer to "Overheat warning system" on page 2-11.

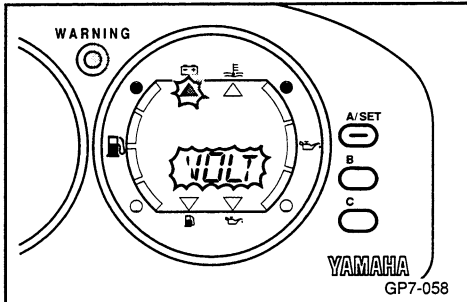

● **Low battery voltage**

If the battery voltage becomes less than 11.5 volt, the low battery voltage indicator, "VOLT" and the warning indicator lamp begin to blink. The buzzer also starts sounding. If this happen during operation, beach the vehicle. Then recharge the battery and inspect the charging system at Yamaha water vehicle dealer.

**NOTE:**

- In warning indicators operation, the warning indicators will operate for 30 seconds after stopping the engine.
- The buzzer will stop sounding, If any button has been pressed.



E

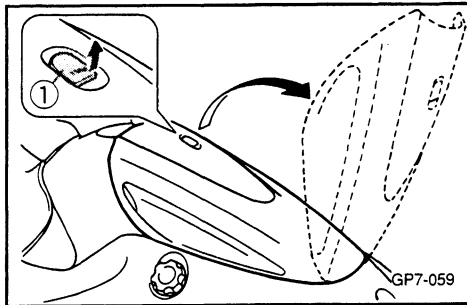

EJU00404

### STORAGE COMPARTMENT

A front storage compartment, a storage compartment, and a seat storage compartment are provided.

#### Front storage compartment

A front storage compartment is provided at front end of the vehicle.

#### ● Opening

Pull up on the hatch lock lever to open the front hood. To access the engine compartment, lift out the storage compartment.

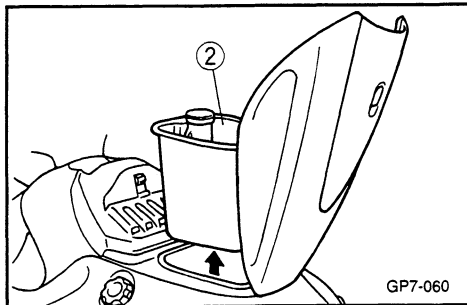

① Hatch lock lever

② Front storage compartment

Capacity: 16.5 L (4.4 US gal, 3.6 Imp gal)

Load limit: 5 kg (11.0 lb)

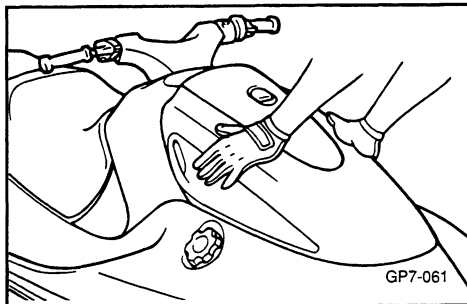

#### ● Closing

Be sure the storage compartment is in place, then close the front hood and push down on the top of the hood until it locks.

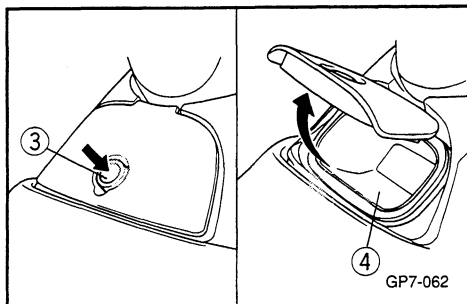

#### Storage compartment

A storage compartment is provided below the handle bars. Push the latch button to open the compartment. Close the hood and push the hood down to lock it.

③ Latch button

④ Storage compartment:

Capacity: 1 L (0.26 US gal, 0.22 Imp gal)

Load limit: 1 kg (2.2 lb)



E

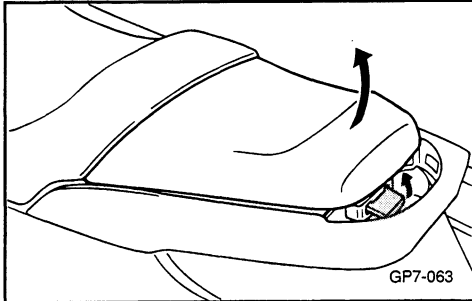

**Seat storage compartment**

A seat storage compartment is provided under the rear seat.

- ⑤ Seat storage compartment  
Capacity: 21.2 L (5.6 US gal, 4.7 Imp gal)  
Load limit: 9 kg (19.8 lb)

**NOTE:**

Make sure the front hood, the water-resistant storage compartment, and the seat storage compartment are firmly secured before riding.

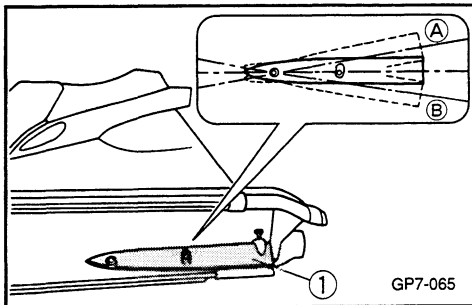
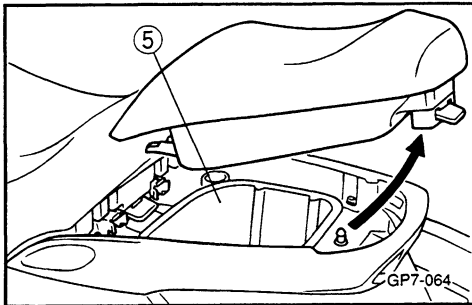

EJU00409

**YAMAHA ADJUSTABLE SPONSON (Y.A.S.)**

The sponsons have adjustable positioning to allow the operator to enhance either straight-line performance or turning performance according to the preference and operating conditions.

- ① Sponson

**Adjusting to upward ①**

There will be less water resistance in this position, so straight-ahead acceleration when on plane and top speed will be enhanced.

**Adjusting to downward ②**

This position will give the water vehicle more "hook" which will enhance turning performance.



EJU00410

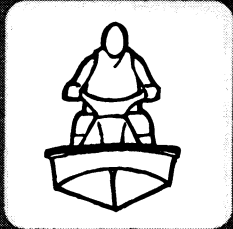

# Chapter 3 OPERATION AND RIDING

**GASOLINE (PETROL) AND ENGINE**

**OIL FILLING**.....3-1  
 Filling the Gasoline (petrol) tank .....3-1  
 Filling the oil tank.....3-2

**PRE-OPERATION CHECKS** .....3-3  
 Check list.....3-3  
 Check point .....3-4

**OPERATION**.....3-10  
 Break-in (Running-in).....3-10  
 Starting the engine .....3-12  
 Stopping the engine .....3-15

**RIDING YOUR WATER VEHICLE** .....3-16  
 Getting to know your water  
 vehicle .....3-16  
 Learning to ride your water  
 vehicle .....3-16  
 Riding with a passenger.....3-17  
 Starting.....3-18  
 Boarding and starting  
 in deep water.....3-19  
 Load limit .....3-21  
 Capsized water vehicle.....3-22  
 Turning.....3-23  
 Stopping .....3-24  
 Beaching .....3-24  
 Docking .....3-25  
 Rough water operation .....3-25

**POST-OPERATION CHECKS** .....3-26

**TRANSPORTATION** .....3-28



EJU00411

## GASOLINE (PETROL) AND ENGINE OIL FILLING

This engine uses Yamaha's oil injection system, which provides superior lubrication by ensuring the proper oil ratio for all operating conditions. No fuel premixing is necessary (except during break-in / running-in). Simply pour gasoline (petrol) into the fuel tank and oil into the oil tank.

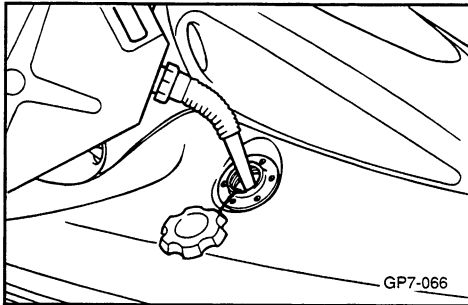

EJU00414

### FILLING THE GASOLINE (PETROL) TANK

- 1) Remove the rear and front seats, so you can watch the fuel level.
- 2) Open the fuel tank filler cap, and slowly add fuel to the fuel tank. Be careful not to spill fuel or overfill the tank.
- 3) Stop filling when the fuel just reaches the bottom of the filler tube on the top of the fuel tank. Do not fill into the filler tube, because gasoline (petrol) could spill out.

#### CAUTION:

Be careful when refueling. Avoid getting water or other contaminants in the fuel tank. Contaminated fuel can cause poor running or engine damage.

Fuel tank capacity:  
50 litres (13.2 US gal, 11 Imp gal)



EJU00419

**FILLING THE OIL TANK**

- 1) Remove the rear and front seats, so you can watch the oil level.
- 2) Open the oil tank filler cap, and very slowly add engine oil to the oil tank.
- 3) Stop pouring when the oil just reaches the bottom of the filler tube.

**CAUTION:**

Do not allow the oil tank to empty completely. The oil injection pump must be bled to ensure proper oil flow after the tank empties. Otherwise, engine damage may occur. If bleeding of the oil pump is necessary, take the water vehicle to your nearest Yamaha dealer.

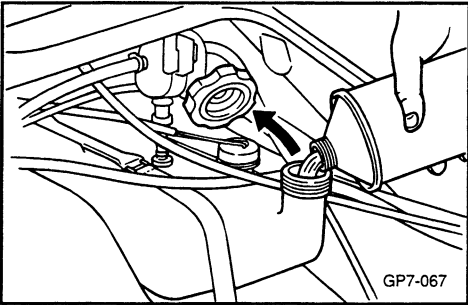

Oil tank capacity:  
4.0 litres (1.06 US gal, 0.88 Imp gal)

**WARNING**

Oil in the bilge is a serious fire hazard. Wipe up any spilled oil immediately.



EJU00422

## PRE-OPERATION CHECKS

### CHECK LIST

Before operating this water vehicle, perform the following checks:

#### **⚠WARNING**

**If any item in the Pre-Operation check is not working properly, have it inspected and repaired before operating the water vehicle. Otherwise an accident could occur.**

ITEM	ROUTINE	PAGE
ENGINE COMPARTMENT	Open seat and storage compartment, and ventilate the engine compartment.	3-4
BILGE	Check, and remove all water and fuel residue before launching	3-5
THROTTLE	Check for proper throttle operation	3-7
STEERING	Check for proper steering operation	3-7
FUEL AND OIL	Check fuel and oil level; add as necessary. Check for leaks.	3-4
WATER SEPARATOR	Check retaining water, drain it if retaining.	3-5
BATTERY	Check fluid level and charge condition	3-6
ENGINE HOOD	Check each latches at seats and front hood are secured.	—
SEAT	Check that the seat is securely fastened to the deck	—
HULL	Check the hull for damage or cracks	—
JET (WATER) INTAKE	Check that no debris is in the intake	3-8
FIRE EXTINGUISHER	Check readiness of the extinguisher	3-6
SWITCHES AND LANYARD	Check operation of the starter, stop switch and engine stop switch lanyard when the vehicle is in the water	3-8
COOLING WATER PILOT OUTLET	Check that water comes out while the engine is running	3-9

#### **NOTE:**

Pre-operation checks should be made each time the vehicle is used. This procedure can be accomplished thoroughly in a short time. The added safety and reliability the checks assure is worth the time involved.



E

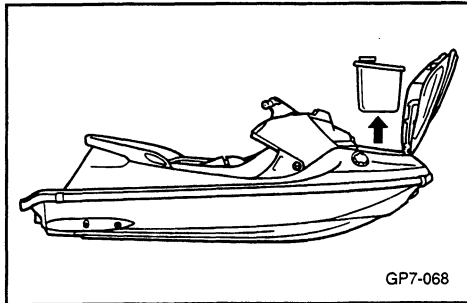

EJU00426

### CHECK POINT

#### Engine compartment

Remove the rear and front seats to ventilate the engine compartment. Allow the engine compartment to remain open for a few minutes to allow any fuel vapors to escape.

### ⚠WARNING

Failure to ventilate the engine compartment to release fuel vapors could result in fire or explosion. Do not start the engine if you can smell fuel vapors in the engine compartment.

EJU00427

#### Fuel system

Refer to page 4-10 "FUEL SYSTEM INSPECTION" for correct procedure.

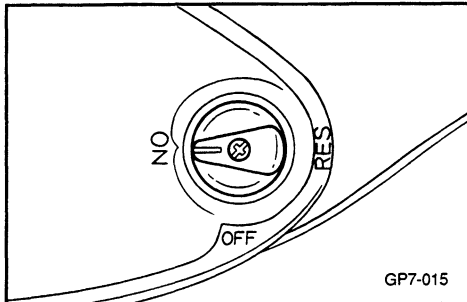

EJU00430

#### Fuel and engine oil

- 1) Remove the fuel tank filler cap to release any pressure which might have built up in the tank because of fuel expansion.
- 2) Remove the rear and front seats.
- 3) Check the fuel and oil level (oil injection model) in the tank and add as necessary. (Refer to page 3-1 "GASOLINE (PETROL) AND ENGINE OIL FILLING")
- 4) Turn the fuel cock knob to the "ON" position.



E

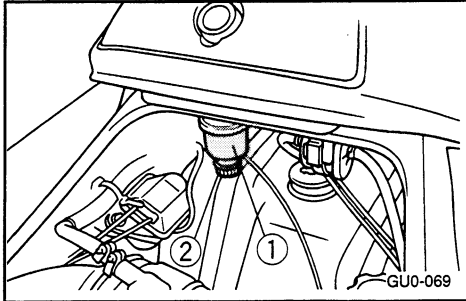

EJU00432

### Water separator

- 1) Check the water separator to see if there is any water in this separator.

This water separator retains any water entering through the fuel tank breather pipe if the Vehicle is cap-sized.

Normally this water separator is empty. (No water)

- 2) If water remains in this water separator, drain it by removing the drain screw.

Don't forget to reinstall the drain screw.

① Water separator

② Drain screw

EJU00433

### Bilge

Excessive water in the engine compartment bilge can splash into the carburetor and engine. This could cause engine damage. If there is any moisture in the bilge, raise the front of the Water Vehicle about 30 cm (12 in.) and remove the hull drain plugs. After the water has drained, wipe the bilge with dry rags. Reinstall the drain plugs.

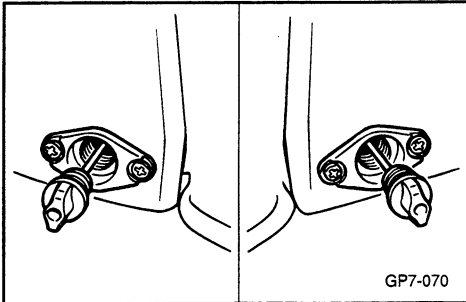

### CAUTION:

**Tighten two hull drain plugs securely before launching the Water Vehicle. Clean any foreign material, such as dirt or sand, from the threads before installing the drain plugs.**

### WARNING

**Always properly dispose of gasoline (petrol) soaked rags. They can spontaneously ignite.**



E

EJU00435

### **Battery**

Check the battery condition and the battery electrolyte level.

### **⚠ WARNING**

The battery must always be fully charged and in good condition. Loss of battery power may leave you stranded. Never operate the water vehicle if the battery does not have sufficient power to start the engine or if it shows any other signs of decreased power.

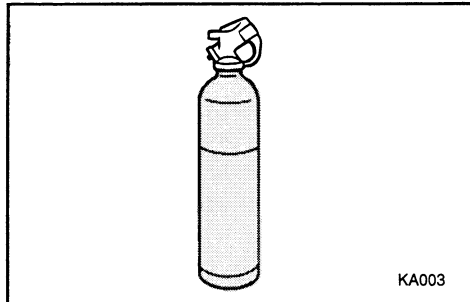

EJU00445

### **Fire extinguisher**

Make sure the fire extinguisher is aboard and full. See the instructions supplied by the fire extinguisher manufacturer to determine proper indication of condition. Always keep the extinguisher in the fire extinguisher compartment.

### **NOTE:**

Always carry a fire extinguisher on board.

A fire extinguisher is not standard equipment with this vehicle. If you do not have one, contact your local Yamaha Water Vehicle dealer or a fire extinguisher dealer to obtain one meeting the proper specifications.

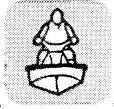

E

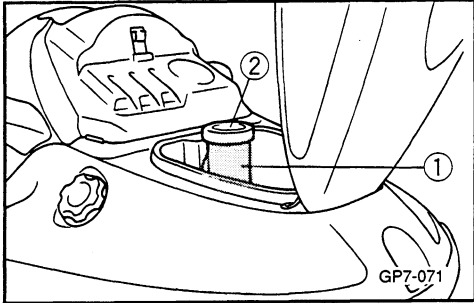

The fire extinguisher compartment is in the front storage compartment. Open the front hood and turn the fire extinguisher compartment cap counterclockwise to open it.

- ① Fire extinguisher compartment
- ② compartment cap

Be sure to reinstall the cap and tighten it securely after inserting the fire extinguisher into the compartment.

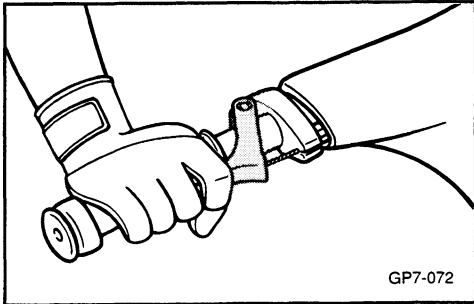

EJU00447

### Throttle

Operate the throttle lever several times to make sure there is no hesitation in its travel. It should be smooth over the complete range, and spring back to the idle position on its own when released.

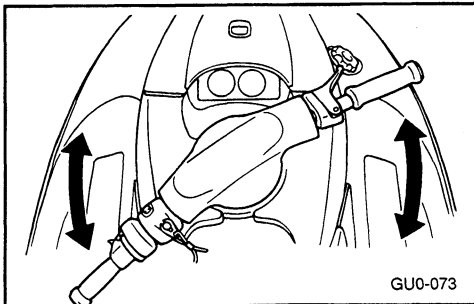

EJU00448

### Steering

Make sure the handlebars are not loose. Turn them full-right and full-left to make sure operation is smooth and unrestricted throughout the whole range. Make sure the jet nozzle also changes directions as the handlebars are turned, and that there is no free play between the handlebars and the jet nozzle.



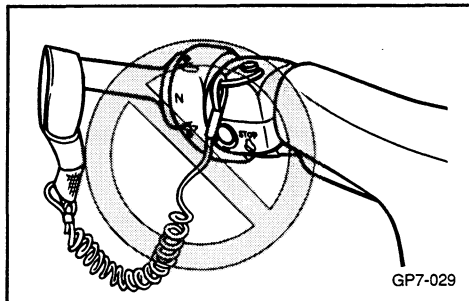

EJU00451

**Jet intake**

Carefully check the jet intake for weeds, debris, or anything else that might restrict the intake of water. If the intake is clogged, cavitation could occur, reducing jet thrust, and possibly damaging jet pump parts. In some cases, the engine may overheat because of lack of cooling water, and damage could result. Engine cooling water is fed to the engine by the jet pump (see pages 5-3).

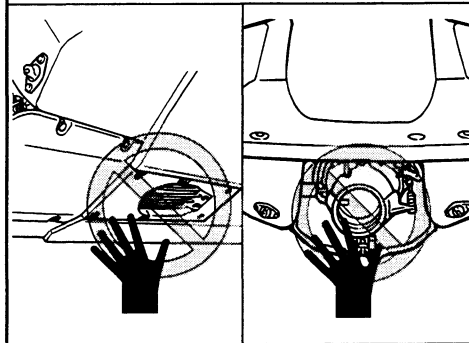

**⚠ WARNING**

Before attempting to remove weeds or debris from the jet intake or impeller areas, shut off the engine and remove the engine stop switch lock-plate from the stop switch. Severe injury or death could result from coming in contact with the rotating parts of the jet pump.

EJU00452

**Switches**

First, place the vehicle in the water to provide adequate engine cooling. Start the engine, then pull the engine stop switch lanyard on your left wrist to remove the lock plate from the switch. Verify that the engine stops immediately. Be sure the lanyard is in good condition with no frayed or broken parts. A damaged lanyard must be replaced; it should never be repaired or tied together. Refer to pages 3-12 to 3-14 "STARTING THE ENGINE", for information on proper operation of the starter switch.

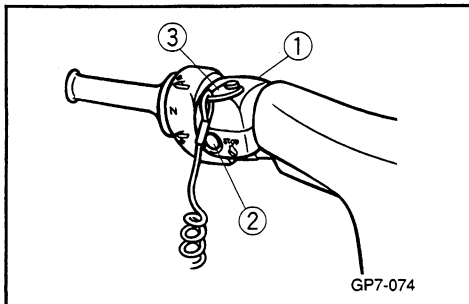

- ① Starter switch
- ② Engine stop switch
- ③ Lock-plate

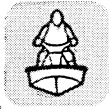

E

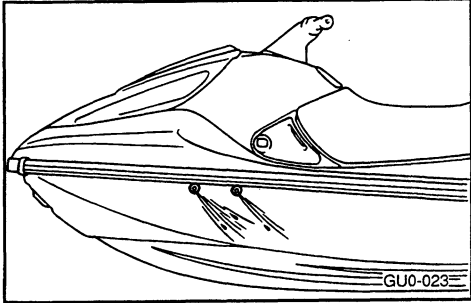

EJU00453

**Cooling water pilot outlet**

Check that water comes out from the outlet while engine is running in the water. Refer to page 2-9 for correct operation of the device.

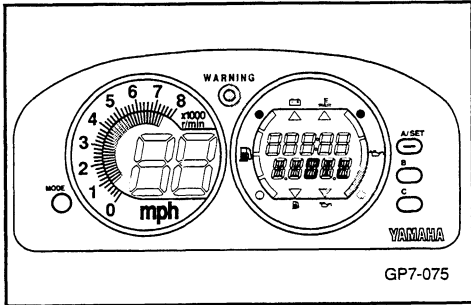

EJU00454

**Multifunction meter**

Check the operation of multifunction meter. Refer to page 2-13 "MULTIFUNCTION METER" for correct meter operation.

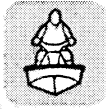

E

EJU00455

## OPERATION

### **⚠ WARNING**

Before operating your water vehicle, become familiar with all controls. Consult your Yamaha dealer about any control or function you do not fully understand. Failure to understand how controls work could cause an accident or prevent you from avoiding an accident.

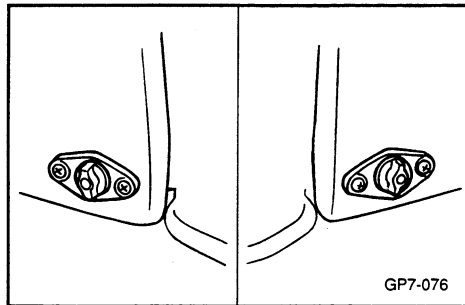

### **CAUTION:**

There are two hull drain plugs near the jet unit on the stern side. Be sure they are securely tightened before launching the Water Vehicle.

EEJU00459

### **BREAK-IN (RUNNING-IN) PROCEDURE**

The engine and other components require a break-in (running-in) period to allow surfaces of moving parts to wear in evenly. This ensures proper performance and promotes longer component life.

### **CAUTION:**

- During first tankful of operation, use 50 : 1 premix fuel (in addition to oil in oil tank).
- After above period, use straight gasoline (petrol) for normal operation.



E

- 1) Launch the vehicle and start the engine.

**⚠ WARNING**

Never ride in water that is less than 60 cm (2 feet) deep. You increase your chance of hitting an underwater obstacle. You could be injured. Operate at higher speeds only in deep water free of under water obstacles.

- 2) Run the engine at the lowest possible speed for the first five minutes.
- 3) Gradually open the throttle to 3/4 or less.
- 4) Continue operation at 3/4 - throttle or less until the first tankful of fuel has been used up.
- 5) Fill the tank with a straight gasoline, and proceed with normal operation.

**CAUTION:**

Failure to follow the break-in (running-in) procedure properly can result in severe damage to the engine.



E

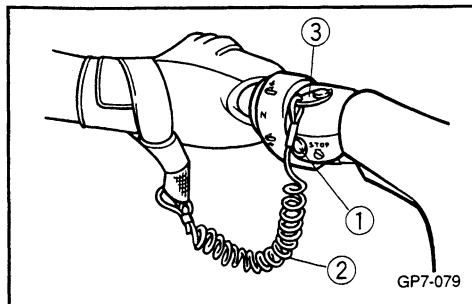
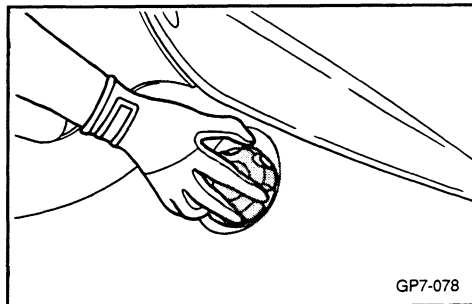
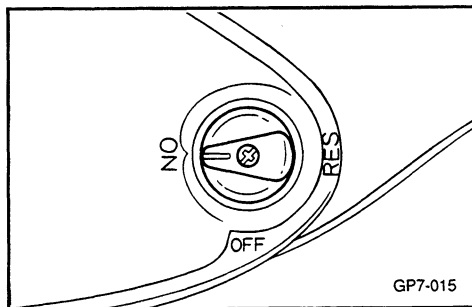
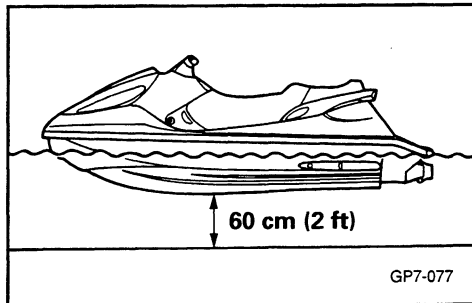

EJU00461

### STARTING THE ENGINE

- 1) Always make sure the vehicle is launched and used in waters that are free from weeds and debris, and in depths of at least 60 cm (2 feet).

#### **WARNING**

Never ride in water that is less than 60 cm (2 feet) deep. You increase your chance of hitting an underwater obstacle. You could be injured. Operate at higher speeds only in deep water free of under water obstacles.

#### **CAUTION:**

Never ride in water that is less than 60cm (2 feet) deep. Pebbles or sand could be sucked into the jet intake, causing impeller damage or engine overheating.

- 2) Turn the fuel cock knob to the "ON" position.

#### **NOTE:**

Before the first start-up, remove the fuel tank filler cap to release any built-up pressure in the tank because of fuel expansion.

- 3) Install the lock-plate on the top of the engine start/stop switch box and pushing the small tab over the barrel beneath the knob, attach the lanyard to your left wrist.

- ① Engine stop switch
- ② Engine stop switch lanyard
- ③ Lock-plate attached to the lanyard

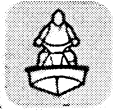

E

**⚠WARNING**

Check that the lanyard is not frayed or broken, wrapped around the handlebar, or tangled in controls. If the operator falls off, the vehicle could continue to run and cause an accident.

The operator would also be unable to rebound the vehicle, which increases the chance of being hit by another boat and the risk of exposure.

**NOTE:**

It is not possible to start the engine with the lock-plate removed from the engine stop switch.

4) Pull the choke knob all the way out.

**NOTE:**

- Hold the choke knob completely pulled for a secure start of cold engine.
- After the engine has warmed up, push the choke knob in. The choke should not be used when the engine is warm.

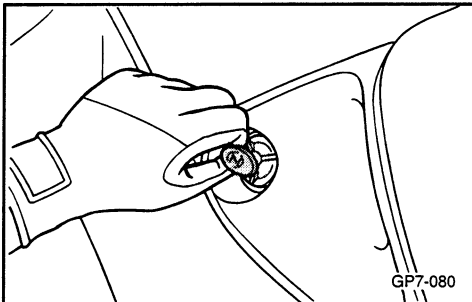

5) If the "LOCK" mode was chosen previously, chose the "START" mode before starting the engine. To set the mode, refer to "PADLOC" in "MULTI-FUNCTION METER".

**NOTE:**

- If initial setting of the PADLOC has not been done, the "START" mode is automatically selected.
- If you have previously chosen "LOCK" mode, the engine will not start unless the right code is put in to select "START" mode.

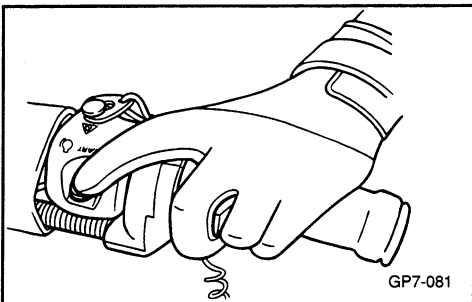

6) While lightly squeezing the throttle lever, push the starter switch button.

**⚠WARNING**

On this vehicle, the engine is connected directly to the drive unit. Starting the engine immediately generates some thrust. Only enough throttle should be applied to keep the engine at a fast enough idle to stay running.

- 7) As soon as the engine starts to run, release the starter button at once. The starter button returns to its home position automatically.

**CAUTION:**

Never push the starter switch while the engine is running. Do not keep the starter motor running for more than five seconds. If the engine does not start after five seconds of cranking, release the starter button. Wait at least 15 seconds before trying to start the engine again. If the starter motor is engaged continuously for more than five seconds, the battery will be quickly discharged, and it will be impossible to start the engine. The starter motor may also be damaged if it is engaged continuously for more than five seconds.

- 8) After the engine is warm, push the choke knob in fully, to its original position.

**NOTE:**

If the choke knob is left pulled out, the engine will stall.



E

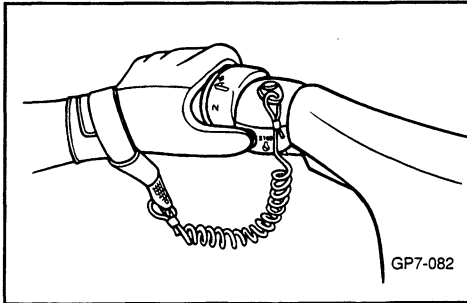

EJU00463

### STOPPING THE ENGINE

To stop the engine, release the throttle lever, then push and hold the stop switch with your left hand. When the button is pushed the ignition stops, which stops the engine.

#### **▲WARNING**

**You need engine power to turn. Shutting off the engine can cause you to hit an obstacle you are attempting to avoid. A collision could result severe injury or death.**

#### **NOTE:**

If leaving the water vehicle, choose the "LOCK" mode on multifunction meter by setting PADLOC, and remove the engine stop switch lanyard to reduce the chance of unauthorized use or theft. To set the mode, refer to "PADLOC" of "MULTI-FUNCTION METER".





EJU00466

## **RIDING YOUR WATER VEHICLE**

### **GETTING TO KNOW YOUR WATER VEHICLE**

Riding your water vehicle requires skills acquired through practice over a period of time. Take the time to learn the basic techniques well before attempting more difficult maneuvers.

Riding your new water vehicle can be a very enjoyable activity, providing you with hours of pleasure. But it is essential to familiarize yourself with the operation of the water vehicle to achieve the skill necessary to enjoy riding safely. Before you begin to ride be sure you have read this Owner's Manual completely and understand the operation of the controls. Pay particular attention to the safety information on pages 1-6 to 1-11. Read all caution and warning labels on your water vehicle.

Also read the Riding Practice Tips booklet supplied with your vehicle.

Remember: Your water vehicle is designed for one operator and one passenger only. Never have more than two people on the vehicle at any time.

EJU00472

## **LEARNING TO RIDE YOUR WATER VEHICLE**

Before riding, always perform the Pre-Operation Checks listed on page 3-3. The short time spent checking the machines condition will reward you with added safety and a more reliable water vehicle. Check state and local laws before operating your water vehicle. Read the Boat Handling Instructions issued by the U.S. Coast Guard for basic safe boating information.

Select a wide area to learn in, where visibility is good and other boat traffic is light. Have someone in a boat accompany you if operating far from shore. Keep the proper distance from other boats and vehicles. Do not ride where people are swimming.

Always attach the engine stop switch lanyard to your left wrist before operating. You must always wear a U.S. Coast Guard approved personal flotation device. Strong streams of water from the jet nozzle, or impact with the water surface can be dangerous. You must wear a wetsuit. Normal swimming attire may not adequately protect you. A wetsuit will help protect against internal injuries to orifices (rectum and vagina) from strong jet streams, and from impact with the water surface. Wetsuits also help protect against hypothermia (low body temperature) and abrasions.

You should wear water shoes to help protect feet from objects hidden under water. Wearing gloves can also help protect hands from abrasions.



E

Wind, water, and glare from the sun may get in your eyes while you operate your water vehicle, reducing your ability to see. You may want to consider wearing eye protection such as sunglasses or goggles while riding. Some may find, however, that eye protection obstructs or distorts their vision, and distracts from operation. Only you know the circumstances in which you operate your water vehicle, so only you can decide if the benefits of eye protection outweigh the potential hazards.

You should grip the handlebars firmly and keep both feet on the footrest floor. Do not attempt to ride with a passenger until your riding skills are fully developed.

EJU00476

### **RIDING WITH A PASSENGER**

When two persons (including the operator) are on board, the vehicle handles differently, and is not as easy to maneuver, so operating it requires a higher degree of skill. Before attempting to operate the water vehicle with a passenger aboard, the operator must practice enough riding alone to be able to acquire the necessary skills.

The passenger must always wear U.S. Coast Guard approved personal flotation devices.

Strong streams of water from the jet nozzle, or impact with the water surface can be dangerous. Both operator and a passenger must wear wetsuits. Normal swimming attire may not adequately protect you. A wetsuit will help protect against internal injuries to orifices (rectum

and vagina) from strong jet streams, and from impact with the water surface. Wetsuits also help protect against hypothermia (low body temperature) and abrasions.

Both operator and a passenger should wear water shoes to help protect feet from objects hidden under water. Wearing gloves can also help protect hands from abrasions.

Wind, water, and glare from the sun may get in your eyes while you operate your water vehicle, reducing your ability to see. You may want to consider wearing eye protection such as sunglasses or goggles while riding. Some may find , however, that eye protection obstructs or distorts their vision, and distracts from operation. Only you know the circumstances in which you operate your water vehicle, so only you can decide if the benefits of eye protection outweigh the potential hazards.

This water vehicle is designed to carry one operator and one passenger, as long as the total weight does not exceed 160 kg (353 lb).

The operator should grip the handlebars firmly and keep both feet on the footrest floor. Do not give a ride to a child whose feet cannot reach the footrest floor. The passenger(s) should hold on firmly to the person in front of them and keep both feet on the footrest floor.

### **▲WARNING**

**When a passenger is on board, make sure he or she is holding on firmly before you start to accelerate.**



EJU00484

### STARTING

#### **⚠WARNING**

- There may be other water craft, obstructions, or swimmers around you. Check carefully before starting off to avoid an accident.
- Practice getting on board in shallow water before riding in deep water.

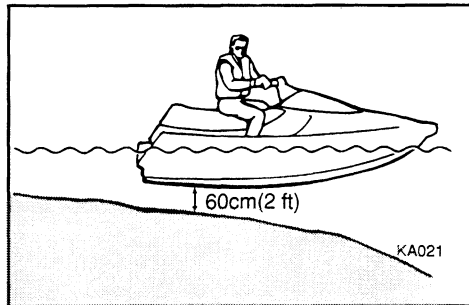

EJU00486

#### **Starting in shallow water**

- 1) Do not start your water vehicle in less than 60 cm (2 feet) of water. Put it in an area that is deep enough, then board the vehicle from the side or the rear.
- 2) Attach the lanyard to your left wrist, then install the lock plate on the lanyard to the engine stop switch.
- 3) Grip the handlebars with both hands, place both feet on the footrest floor, start the engine, and start off.

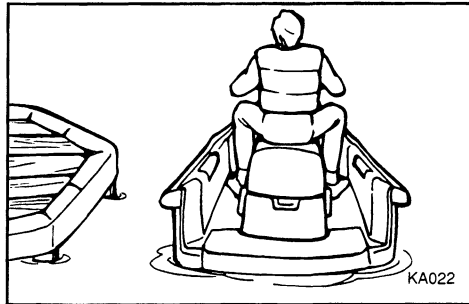

#### **Starting from a landing jetty**

- 1) Board the vehicle from the side.
- 2) Attach the lanyard to your left wrist, then install the lock plate on the lanyard to the engine stop switch.
- 3) Push the vehicle away from the jetty, grip the handlebars with both hands, place both feet on the footrest floor, start the engine, and start off.



E

EJU00490

## BOARDING AND STARTING IN DEEP WATER

### **⚠WARNING**

- Operator and passenger should practice getting on board in shallow water before riding in deep water. Reboarding in deep water requires more skill.
- The fatigue and exposure that could result after unsuccessful attempts to get back on the vehicle may increase the risk of injuries and drowning.

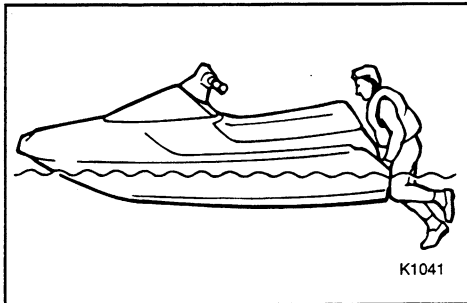

K1041

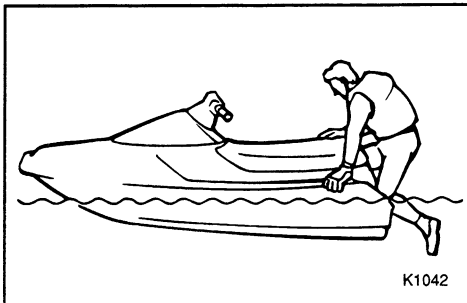

K1042

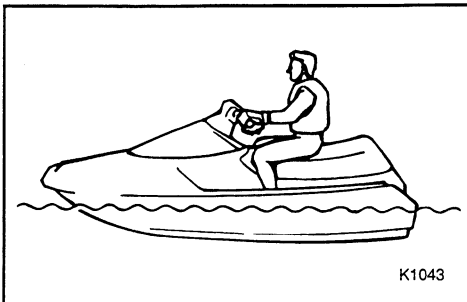

K1043

### Solo

- 1) Swim to the rear of the vehicle and place both hands on the footrest floor. Pull yourself up on the floor and kneel down.
- 2) Move to the seat and sit astride.
- 3) Attach the lanyard to your left wrist, then install the lock plate on the lanyard to the engine stop switch.
- 4) Grip the handlebars firmly with both hands, place both feet on the footrest floor, start the engine, and start off.

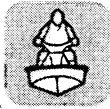

E

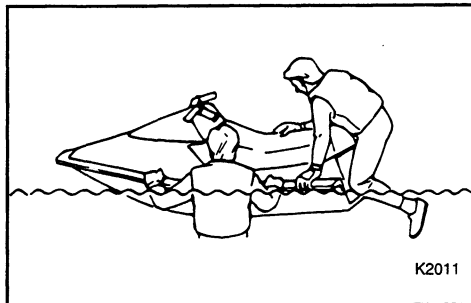

K2011

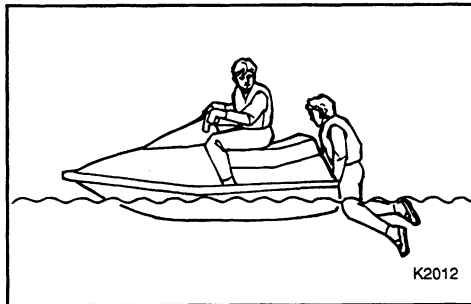

K2012

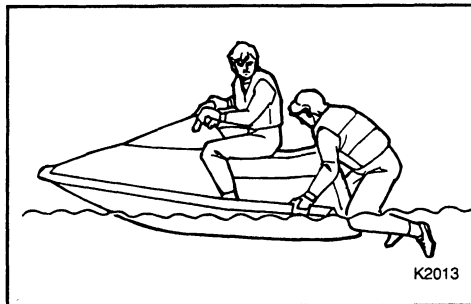

K2013

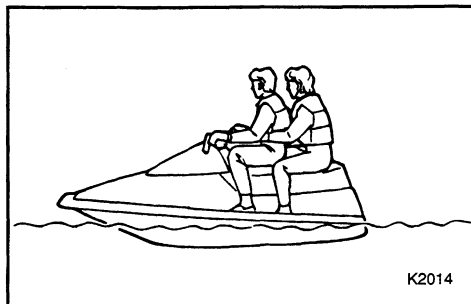

K2014

EJU00492

### With a passenger

#### **WARNING**

Strong streams of water from the jet nozzle can be dangerous, and can result in injury when directed at body orifices (rectum and vagina). Do not open the throttle until each passenger is seated with feet on the floor and is holding on to the person in front of him or her.

- 1) Climb up on board as noted earlier, and sit astride the seat. Attach the lanyard to your left wrist, then install the lock plate on the lanyard to the engine stop switch.
- 2) The passenger should move to the rear of the vehicle.
- 3) Next, let the passenger get on board and sit on the rear portion of the seat.

#### **NOTE:**

When letting the passenger get on board, both he and operator should try to balance the vehicle.

- 4) The operator should check to see that the passenger has his feet on the footrest floor and is holding the operator tightly, then start the engine, and accelerate to planing speed.

#### **WARNING**

Before starting off, make sure there are no boats, obstructions, or swimmers around you.

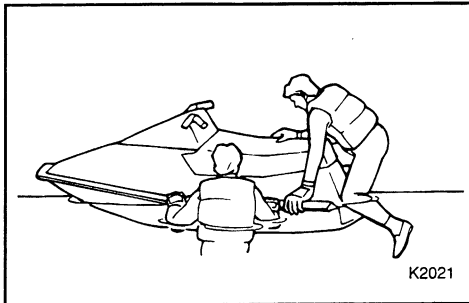

EJU00494

**LOAD LIMIT**

The heavier the total weight of the operator and passenger, the more difficult it will be to balance the water vehicle. It is not advisable to ride the vehicle when the total weight exceeds 160 kg (353 lb) including any cargo.

If it is difficult to balance the vehicle at a standstill, proceed as follows:

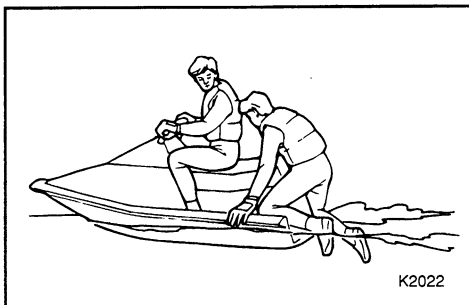

- 1) The passenger must steady the water vehicle while the operator is boarding. The operator pulls himself up onto the footrest floor into a seating position, then balances the vehicle.
- 2) Attach the lanyard to your left wrist, then install the lock plate on the lanyard to the engine stop switch. Start the engine and keep it at idle.
- 3) The passenger pulls himself up on the floor, kneels down, then crawls onto the seat as the vehicle accelerates.

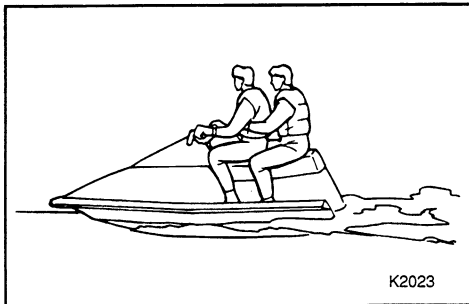
**⚠WARNING**

**Strong streams of water from the jet nozzle can be dangerous, and can result in injury when directed at body orifices (rectum and vagina). Do not open the throttle until each passenger is seated with feet on the floor and is holding on to the person in front of him or her.**

- 4) The water vehicle can now be accelerated to planing speed, then the operator can reduce the throttle to the desired running speed.

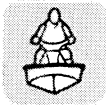

E

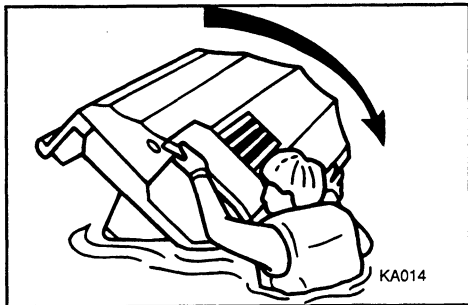
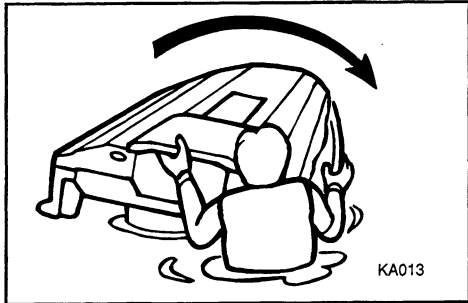

EJU00497

**CAPSIZED WATER VEHICLE**

- 1) Turn off the engine by removing the engine stop switch lock-plate. The engine will overheat when capsized because it has no water to pump as coolant.
  
- 2) Swim to the rear side of the vehicle. Pull the vehicle over clockwise with the left hand on the ride plate while pushing down on the gunwale with your right hand/foot. Do not turn the vehicle counterclockwise, or water may leak into the carburetor and engine.

**NOTE:** \_\_\_\_\_  
If the right side of the capsized vehicle (view from rear of the vehicle) tilts upward, first tilt the vehicle so the right side is down by pressing down on the gunwale with your weight. Then turn the vehicle over as described.

- 3) Start the engine using normal procedure, then head for shore to inspect engine for water damage.

**⚠ WARNING** \_\_\_\_\_

**IMPROPER UPRIGHTING CAN CAUSE INJURY:**

- Shut off engine.
- Do not put hand in intake grille.
- Watch so you are not hit by vehicle as it comes over.

**TO TURN OVER:**

- Pull vehicle over with left hand on ride plate while pushing down on gunwale with right hand/foot.

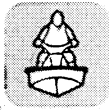

E

**CAUTION:**

If the vehicle has been capsized for 5 minutes or more, air may have entered the oil injection system. Leave the engine off, or operate only at trolling speeds, for 10 minutes after the vehicle has been put right-side up. This will allow any air to bleed off.

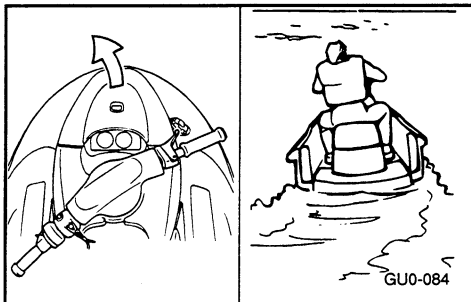
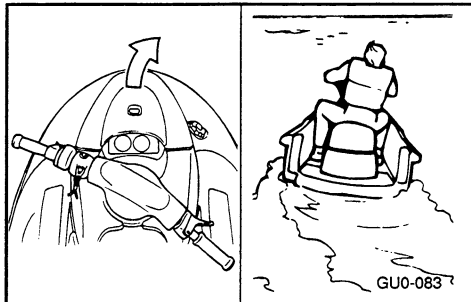

EJU00499

**TURNING**

Throttle produces thrust from the jet pump. Directional control is provided by opening the throttle and turning the handlebars.

To make a turn at higher than trolling speed: Reduce your speed, then turn the handlebars and shift your weight in the desired direction, and apply enough throttle to make your turn. High thrust turns the vehicle sharply; low thrust turns less sharply. Releasing the throttle completely causes the vehicle to go straight. **URNS CANNOT BE MADE WITHOUT APPLYING THROTTLE!**

**WARNING**

- You need engine power to turn. Do not release the throttle completely. Releasing the throttle lever can cause you to hit an obstacle you are attempting to avoid. A collision could result in severe injury or death.
- Make gradual turns at higher speeds or slow down before turning. Sharp turns at higher speeds may cause the vehicle to slide sideways or spin. The passenger(s) and operator could be thrown off suddenly and be injured.



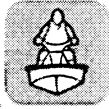

E

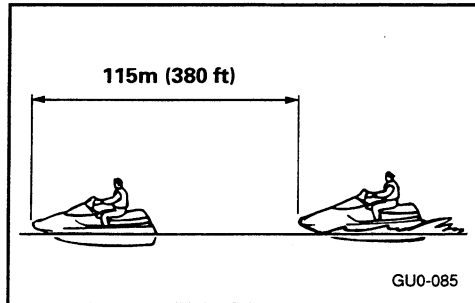

EJU00502

### STOPPING

The water vehicle is not equipped with a separate braking system.

It is stopped by water resistance when the throttle lever is released. From full speed, the water vehicle stops in approximately 115 m (380 feet) after the throttle is released and the engine stopped. The stopping distance varies depending on gross weight, water surface conditions, and wind direction. The stated stopping distance should be used for a reference.

### ⚠WARNING

Allow adequate stopping distance. Failure to begin slowing soon enough could cause you to hit an obstacle you are approaching. Do not shut off the engine when slowing down in case you need engine power to steer away from a boat or other obstacle that comes into your path.

### NOTE:

If maintaining balance is difficult after you reach trolling speed, the passenger, and if necessary, the operator should get off the vehicle.

EJU00503

### BEACHING

- 1) Make sure no obstructions, boats or swimmers are near the beach. Release the throttle lever about 115 m (380 ft) before the intended landing area.
- 2) Approach the beach slowly and stop the engine before reaching landing point. Remember: turning is impossible with the engine stopped.



E

- 3) Get off the vehicle and pull it up on the beach.

**CAUTION:** \_\_\_\_\_

**Small pebbles, sand, seaweed, and other debris can be ingested into the jet intake and impair or damage the impeller. Always stop the engine and get off before beaching the vehicle.**

EJU00505

**DOCKING**

- 1) Make sure no obstructions, boats or swimmers are close to the water vehicle. Reduce speed about 115 m (380 ft) away from the dock.
- 2) Slowly approach the dock and stop the engine just before coming alongside it.

EJU00507

**ROUGH WATER OPERATION**

Operating in rough water or jumping waves can crack the vehicle body or damage internal parts. The force of landing after jumping can cause a strong impact on both the water vehicle and the operator. It is possible for the operator to hit his chest or jaw on the vehicle body or handlebars and be injured. Do not ride with your chin right above the handlebars or with your feet outside the vehicle. Avoid riding in rough water or bad weather conditions.

**⚠WARNING** \_\_\_\_\_

**Operating in rough water or jumping waters can lead to injury. It may also damage the vehicle.**

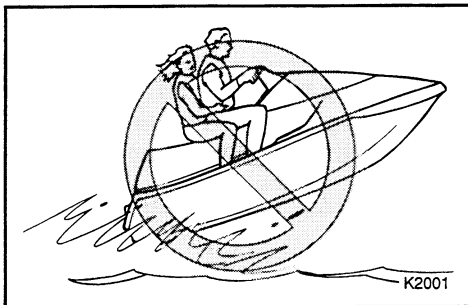



E

EJU00508

## POST-OPERATION CHECKS

- 1) After removing the vehicle from the water, raise the rear of the vehicle 30 cm (12 in.) for a period of 5 to 10 seconds to drain water from the muffler box.

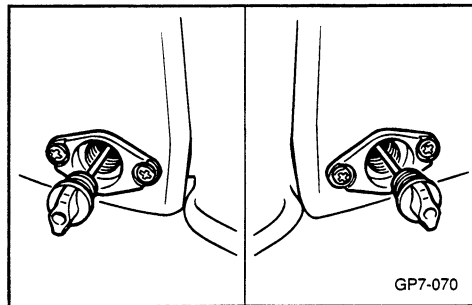

- 2) Flush cooling system to prevent the cooling system from clogging up with salt, sand, or dirt. "Refer to pages 4-1 for the cooling system flushing procedure."

- 3) Lubricate the internal components by performing "LUBRICATION" at page 4-3, if storing the water vehicle for more than a week.

- 4) Drain residual water from the exhaust system by alternately pulling and releasing the throttle lever for a period of 10 to 15 seconds while the engine is running.

### CAUTION:

**Do not attempt to run the engine at full throttle or for more than 15 seconds while the vehicle is out of the water. The engine may overheat and/or seize.**

- 5) After operating the vehicle from the water, wash down the hull, handlebars and drive unit with fresh water.



E

- 6) Raise the front of the Water Vehicle about 30 cm (12 in.) and remove two hull drain plugs. Allow any water in the bilge to drain out.

Rinse the engine compartment with a small amount of fresh water. Be careful not to get water on the carburetor or electrical components. After the water has drained, wipe the bilge with dry rags.

Reinstall two drain plugs.

**NOTE:** \_\_\_\_\_

This vehicle is equipped with an automatic bilge-draining device that removes water from the engine compartment while you are underway.

However, some residual water remains that must be drained by removing two drain plugs.

**⚠WARNING** \_\_\_\_\_

**Always properly dispose of gasoline (petrol) soaked rags. They can spontaneously ignite.**

- 7) Spray a rust inhibitor, such as Yamaha Silicone Protectant and Lubricant, on metallic parts to minimize corrosion.

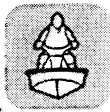

E

EJU00513

## TRANSPORTATION

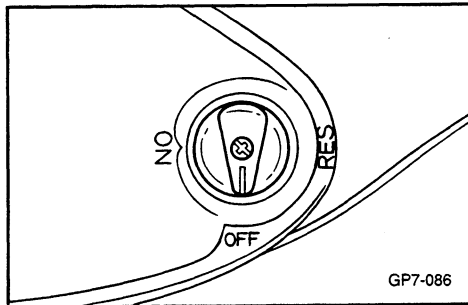

### **WARNING**

Always place the fuel cock in the "OFF" position when transporting the water vehicle. Otherwise, fuel could leak out into the engine or engine compartment, which would create a fire hazard.

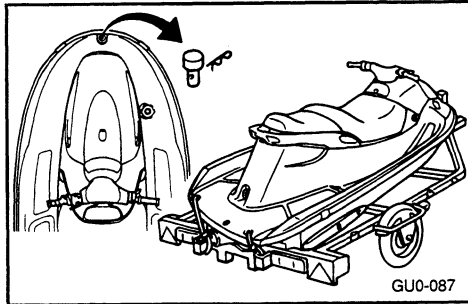

When transporting the water vehicle on a trailer, lock the bow with a pin to the trailer and secure the stern with ropes or tie downs through the rope hole(s) on the rear footrest floor.

### **CAUTION:**

Do not route ropes or tie downs over the seat, as they may leave permanent marks on the seats surface. Also wrap the ropes or tie downs with towels or rags where they touch the body of the water vehicle to avoid scratching or damage.

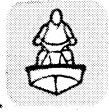

E

---

- MEMO -

EJU00515

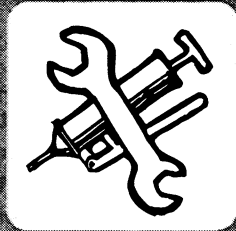

## Chapter 4 MAINTENANCE AND CARE

<b>STORAGE</b> .....	4-1
Cooling system flushing .....	4-1
Lubrication .....	4-3
Fuel system.....	4-5
Battery .....	4-5
Cleaning .....	4-6
<b>ADJUSTMENT AND MAINTENANCE</b> .....	4-7
Owner's manual and tool kit.....	4-8
Periodic inspection chart.....	4-9
Fuel system inspection.....	4-10
Fuel filter .....	4-11
Fuel tank.....	4-11
Oil injection system inspection .....	4-12
Steering cable inspection.....	4-13
Throttle cable inspection and adjustment.....	4-13
Quick shift trim system mechanism inspection .....	4-14
Spark-plug cleaning and adjustment.....	4-15
Greasing points .....	4-16
Choke cable adjustment.....	4-19
Battery .....	4-20
Carburetor adjustment.....	4-22
Fuse replacement.....	4-23
Bleeding the oil injection pump .....	4-23
YAMAHA adjustable sponson adjustment.....	4-24
<b>SPECIFICATIONS</b> .....	4-25



E

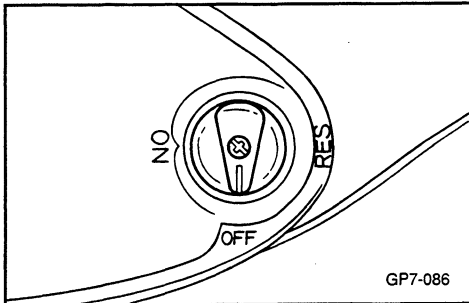

EJU00516

## STORAGE

### **⚠ WARNING**

Always place the fuel cock in the "OFF" position when storing the water vehicle. Otherwise, fuel could leak out into the engine or engine compartment, which would create a fire hazard.

Water vehicle storage for prolonged periods of time, such as winter storage, requires preventative maintenance to ensure against deterioration. It is advisable to have the water vehicle serviced by an authorized Yamaha Water Vehicle dealer prior to storage. However, the following procedures can be performed by the owner with a minimum of tools.

EJU00522

## COOLING SYSTEM FLUSHING

Cooling system flushing is essential in order to prevent the cooling system from being clogged with salt, sand, or dirt.

- 1) Open the cap. Press the flush kit garden hose adapter into the flush hose connector and turn until they are securely connected

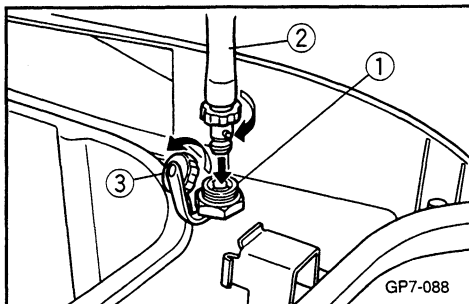

- ① Flush Hose Connector
- ② Garden Hose Adapter
- ③ Cap





E

- 2) Start the engine, then immediately turn on the water supply fully.

**CAUTION:** \_\_\_\_\_

**Never turn on the water before starting the engine. The water could flow back through the muffler into the crankcase causing severe engine damage.**

**Be sure to turn on the water immediately after starting the engine to prevent engine overheating.**

- 3) Run the engine at a fast idle for 10~15 minutes.
- 4) Turn off the water supply and force the remaining water out of the cooling system by quickly opening and closing the throttle several times for 10 to 15 seconds.

**CAUTION:** \_\_\_\_\_

**Never have the water on when the engine is not running. The water could flow back through the muffler into the crankcase causing severe engine damage. Do not run the engine for more than 15 seconds after the water supply has been turned off to avoid engine overheating.**

- 5) After stopping the engine, remove the garden hose adapter.
- 6) Replace the cap securely.



E

EJU00526

## LUBRICATION

### **⚠ WARNING**

To reduce the risk of fire or explosion:  
Never pour or spray gasoline, or any other substance except engine fogging oil through the hole(s) in the carburetor silencer cover.

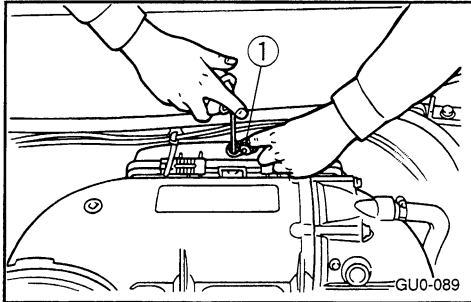

### **CAUTION:**

- Be sure to replace the cap(s) securely after fogging the engine. Otherwise water could enter the engine and cause damage.
- Do not attempt to run the engine at full throttle or for more than 15 seconds while the vehicle is out of the water. The engine may overheat and/or seize.

- 1) Open the cap ① on the carburetor silencer cover.
- 2) With the water vehicle in a well-ventilated area, start the engine.
- 3) With the engine running at a fast idle, quickly spray as much Yamaha Stor-Rite Fogging Oil or an equivalent, as possible into the carburetor through the hole(s) in the silencer cover. Keep spraying until the engine stalls (or a maximum of 15 seconds). Reinstall the cap(s) securely.



E

- 4) Remove the spark plugs and pour approximately one tablespoon of oil into each cylinder.
- 5) Grease the spark plug threads and reinstall the spark plugs.
- 6) Lubricate all cables such as the throttle, choke, and steering cables.

**NOTE:** \_\_\_\_\_  
Use a Yamaha Power Cable Luber and Yamaha Lube-Zall to pressure lubricate the cables and purge out any moisture between the inner and outer cables.

- 7) Grease the areas of the water vehicle specified in "Grease Points" in the ADJUSTMENT AND MAINTENANCE section.



E

EJU00528

### FUEL SYSTEM

- 1) Top off the fuel tank with fresh fuel/oil mixture and add one ounce of Yamaha Fuel Stabilizer and Conditioner to each gallon of fuel.

### NOTE:

Use of Yamaha Fuel Stabilizer and Conditioner eliminates the need to drain the fuel system. Consult your Yamaha dealer or other qualified mechanic if the fuel system is to be drained instead.

EJU00530

### BATTERY

- 1) When the machine is not to be used for a month or more, remove the battery and store it in a cool, dark place. Clean the battery's casing and terminals using a mixture of baking soda and water (one tbsp. of baking soda to one cup of water). Apply dielectric grease or petroleum jelly to the battery terminals and to all exposed connectors.
- 2) If the battery is to be stored for a longer period, check the specific gravity of the fluid at least once a month and recharge the battery if it gets too low.

Specific gravity: 1.28 at 20°C (68°F)



EJU00531

### **CLEANING**

- 1) Wash down the hull, handlebars, and drive unit with fresh water.
- 2) Rinse the engine and bilge area with fresh water. Drain off all water and wipe up remaining moisture with clean, dry rags.
- 3) Spray the engine's exterior with Yamaha Silicone Protectant and Lubricant.
- 4) Wax the hull with a non-abrasive wax such as Yamaha Silicone Wax.
- 5) Wipe all vinyl and rubber components, such as the seat and engine compartment seals, with a vinyl protectant such as Yamaha Protectant.



## ADJUSTMENT AND MAINTENANCE

Periodic inspection, adjustment and lubrication will keep your water vehicle in the safest and most efficient condition possible. Safety is an obligation of the vehicle owner. The most important points of vehicle inspection, adjustment and lubrication are explained on the following pages.

If replacement parts are necessary, use genuine Yamaha parts or the equivalent. Remember that failures which are the result of the installation of parts or accessories which are not qualitatively equivalent to genuine Yamaha parts are not covered by the limited warranty.

### **⚠ WARNING**

Be sure to turn off the engine when you perform maintenance unless otherwise specified. Otherwise, accident or injury could result from unexpected operation, moving parts, or electric shock. If the owner is not familiar with machine servicing, this work should be done by a Yamaha dealer or other qualified mechanic. Improperly serviced components could fail or stop operating correctly, which could result in an accident.

### **⚠ WARNING**

Modifications to this machine not approved by Yamaha may cause loss of performance or excessive noise, or render it unsafe for use. Consult a Yamaha Water Vehicle dealer or other qualified mechanic before attempting any changes.

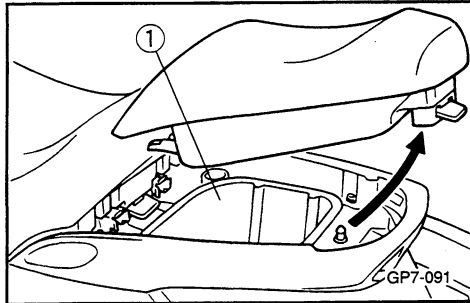

### OWNER'S MANUAL AND TOOL KIT

It is advisable always to carry the Owner's Manual and Tool Kit with you whenever you use the water vehicle. For the convenience of the user, a storage space is provided on the vehicle. (Refer to "STORAGE CONTAINER / STORAGE COMPARTMENT") To protect these materials from water, it would be a good idea to put them in a vinyl bag.

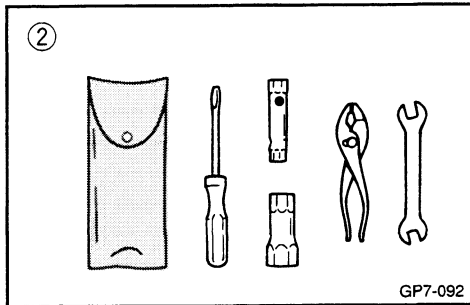

The service information included in this manual is intended to provide you, the owner, with the necessary information for completing your own preventive maintenance and minor repairs. The tools provided in the owner's tool kit are sufficient for this purpose, except that a torque wrench is also necessary to properly tighten nuts and bolts.

- ① Storage space for tool kit and Owner's Manual
- ② Tool kit

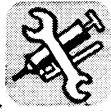

EJU00536

### PERIODIC INSPECTION CHART

Frequency of maintenance operations may be adjusted according to the operating conditions, but the following table gives general guidelines.

The mark (●) indicates the checkups which you may do yourself.

The mark (○) indicates work to be done by your Yamaha dealer.

Maintenance interval		Initial			Thereafter every		Page
		10 hours	50 hours	100 hours	100 hours	200 hours	
			3 months	6 months	6 months	12 months	
Item							
Spark plug	Inspection/Cleaning Adjustment	●	●	●	●		4-15
Greasing points	Greasing			●	●		4-16
Bearing housing	Greasing	○*1		●*2	●*2		4-18
Fuel system	Inspection			○	○		4-10
Fuel filter	Checking/Replacement	○				○	4-11
Fuel tank	Cleaning					○	4-11
Oil injection system	Inspection/Cleaning	○				○	4-12
Carburetor setting	Inspection/Adjustment	○		○	○		4-22
Trolling speed	Adjustment			●	●		4-22
Carburetor throttle shaft	Inspection			○	○		—
Cooling-water passages	Cleaning/Flushing		● (after every ride)				4-1
Bilge strainer	Cleaning		●	●	●		—
Impeller	Inspection		●	●	●		—
Steering cable	Inspection			●	●		4-13
Steering pivot	Inspection	○		○	○		4-17
Throttle cable and choke cable	Inspection/Adjustment			●	●		4-13
Quick shift trim system mechanism	Inspection			●	●		4-14
Drain plugs	Inspection/Replacement					●	—
Battery	Inspection	● (Inspect fluid level before every ride)					4-19
Rubber coupling	Inspection					○	—
Bolts and nuts	Retightening	○		○	○		—

\*1: Grease capacity: 33.0~35.0 cm<sup>3</sup> (1.11~1.18 oz.)

\*2: Grease capacity: 6.0~8.0 cm<sup>3</sup> (0.20~0.27 oz.)





E

EJU00537

## FUEL SYSTEM INSPECTION

### **⚠WARNING**

**Gasoline (Petrol) and its vapors are highly flammable and explosive.**

Check the fuel system for leaks, cracks, or malfunctions. If any problem is found, do the necessary repair or replacement as required. If repair is necessary, consult your nearest Yamaha Water Vehicle dealer.

### **Checking points**

- Carburetor leakage.
- Fuel pump malfunction or leakage.
- Fuel tank leakage.
- Fuel hose joint leakage.
- Fuel hose cracks or other damage.
- Fuel filter leakage.
- Fuel cock leakage.
- Air vent check valve leakage.

### **⚠WARNING**

**Failure to check for and repair fuel leakage may result in fire or explosion.**

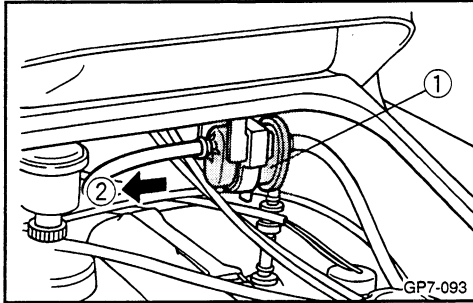

EJU00539

### FUEL FILTER

The fuel filter is a one-piece, disposable type. The filter should be replaced once a year or after every 200 hours of operation, or if water is found in the filter, take the water vehicle to your Yamaha dealer if fuel filter replacement is required.

- ① Fuel filter
- ② Port (left) side

### **⚠ WARNING**

**Do not try to change the fuel filter yourself. An incorrectly installed filter can leak gasoline (petrol), which could lead to fire or explosion. Take the water vehicle to your Yamaha dealer for fuel filter replacement.**

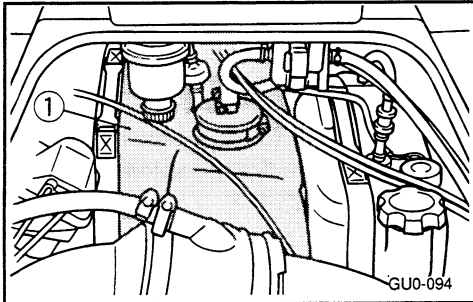

EJU00540

### FUEL TANK

When the fuel tank needs to be cleaned or when any water is found in the fuel system, take the water vehicle to your Yamaha dealer for service.

- ① Fuel tank



E

EJU00544

## OIL INJECTION SYSTEM INSPECTION

Check the oil injection system for leaks, cracks, or malfunctions. If any problem is found, do the necessary repair or replacement as required. If repair is necessary, consult your nearest Yamaha dealer.

### Checking points

- Check the oil tank for damage or cracks.
- Check for water or dirt in the oil tank.
- Check the oil hose and joint.
- Check the oil filter.

### Oil tank

Check for oil tank damage or cracks. Check the oil hose and joint. When the oil tank need to be cleaned, or when any water or dirt is found in the oil tank, take the water vehicle to your Yamaha dealer for service.

### Oil filter cleaning

If the filter is clogged, remove it together with the oil level sender from the oil tank and clean it.

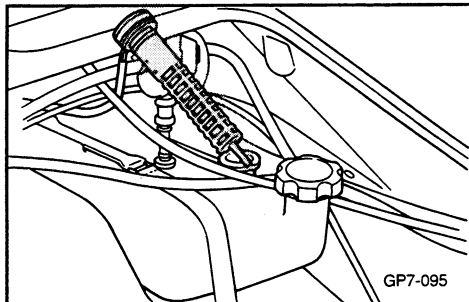



E

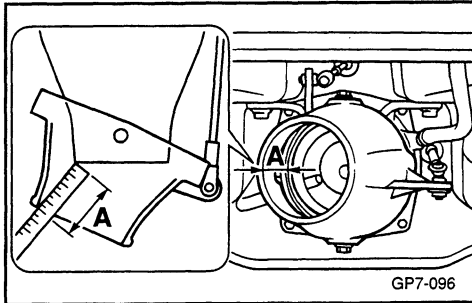

EJU00547

### STEERING CABLE INSPECTION

- 1) Check the smooth operation of the handlebars and steering (jet) nozzle.
- 2) Turn the handlebars from lock to lock and check that the distances between rear end of the steering (jet) nozzle and the nozzle at inside of the steering (jet) nozzle are even on both right and left sides.

**A=B**

If steering is stiff or misadjusted, ask your Yamaha dealer to service it.

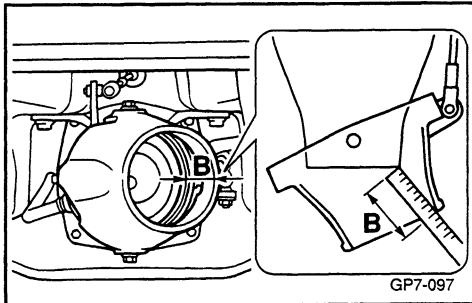

EJU00550

### THROTTLE CABLE INSPECTION AND ADJUSTMENT

- 1) By pulling or releasing the throttle lever, check that it moves back to the set position smoothly. If not, ask your Yamaha Water Vehicle dealer for service.
- 2) Throttle lever free play should be within specification. If it is not, adjust it by loosening the lock nut and turning the adjuster so that throttle lever free play is within specification with the carburetor at idle position.

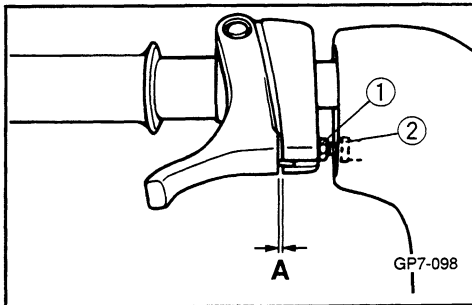

- ① Lock nut
- ② Adjuster

Throttle lever play:  
A=4.0~7.0 mm (0.16~0.28 in)



E

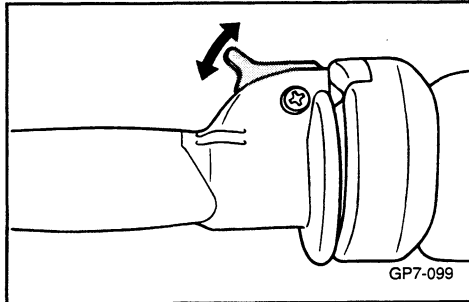

EJU00551

### QUICK SHIFT TRIM SYSTEM MECHANISM INSPECTION

- 1) Squeeze and release the shift lock release lever. It should move smoothly back to the lock position. Check that the trim shifting grip is locked with the lever released.
- 2) Squeeze and hold the lever. Check that the grip turns smoothly.
- 3) Check that the angle of the output nozzle changes to up or down from the middle position when the grip is shifted from neutral to bow-up or bow-down.

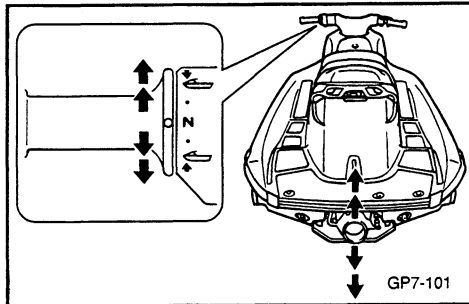
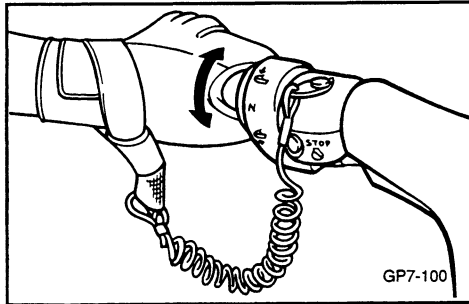

If the mechanism does not work properly, ask your Yamaha Water Vehicle dealer to service it.



E

EJU00552

## SPARK-PLUG CLEANING AND ADJUSTMENT

The spark-plug is an important engine component and is easy to inspect. The condition of the spark-plug can indicate something about the condition of the engine. For example, if the centre electrode porcelain is very white, this could indicate an intake air leak or carburetion problem in that cylinder. Do not attempt to diagnose any problems yourself. Instead, take the water vehicle to a Yamaha Water Vehicle dealer. You should periodically remove and inspect the spark-plug because heat and deposits will cause the spark-plug to slowly break down and erode. If electrode erosion becomes excessive, or if carbon and other deposits are excessive, you should replace the spark-plug with another of the correct type.

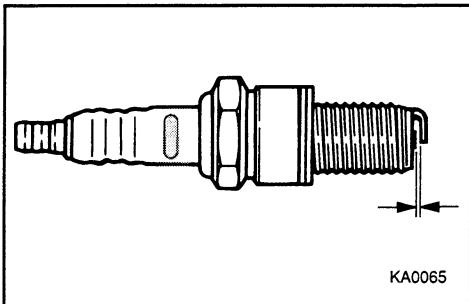

Standard spark plug:  
BR-8ES

Before installing the spark-plug, measure the electrode gap with a wire thickness gauge; adjust the gap to specification if necessary.

Spark-plug gap: 0.7~0.8 mm  
(0.028 ~ 0.031 in)

When fitting the plug, always clean the gasket surface and use a new gasket. Wipe off any dirt from the threads and screw in the spark-plug to the correct torque.

Spark-plug torque:  
25 Nm (2.5 m•kg, 18 ft•lb)

### NOTE:

Before installing the spark plug cap, be sure to wipe off any water on the spark plug or inside the cap. Push the spark plug cap down until it clicks.

### NOTE:

If a torque-wrench is not available when you are fitting a spark-plug, a good estimate of the correct torque (with a new gasket) is 1/4 to 1/2 a turn past fingertight. Have the spark-plug adjusted to the correct torque as soon as possible with a torque wrench.

### WARNING

When removing or installing a spark plug, be careful not to damage the insulator. A damaged insulator could allow external sparks, which could lead to explosion or fire.



E

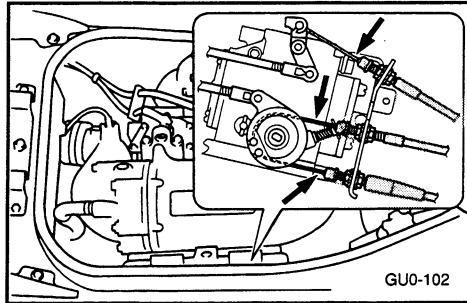

EJU00553

### GREASING POINTS

To keep moving parts sliding or rotating smoothly, coat them with water resistant grease (Yamaha Marine Grease, YAMAHA grease A) or equivalent.

#### Throttle cable and choke cable

- 1) Grease the carburetor throttle cable and choke cable inner wires.

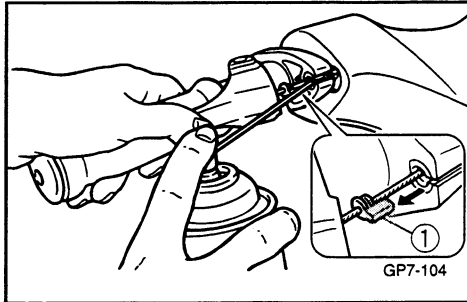

- 2) Pull the throttle lever and remove the seal. Spray a rust-inhibitor into the outer cable. Refit the seal securely.

① Seal

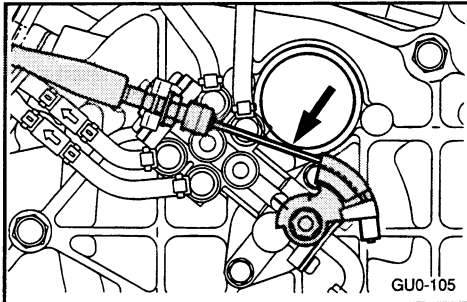

EJU00554

#### Oil pump cable

Grease the oil pump cable inner wire.

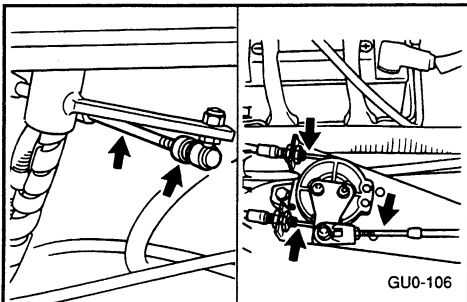

EJU00555

#### Steering cable ball joints and inner wire

- 1) Grease the steering cable ball joints both on the handlebar side and on the steering nozzle side.
- 2) Extend the steering cable inner wire, and apply a thin coat of grease to it both on the handlebar side and on the steering nozzle side.



E

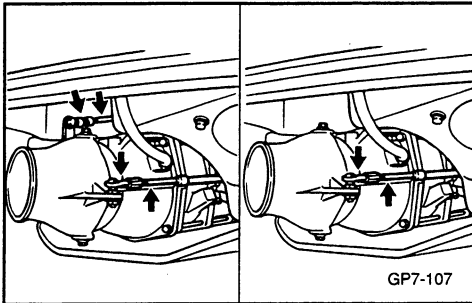

EJU00558

#### Quick Shift Trim System cable joint and inner wire

- 1) Grease the all joints of the system on the under side of the seat storage compartment and at the steering nozzle.
- 2) Extend the inner wire of the trim shift cable under the seat storage compartment. Apply a thin coat of grease to the exposed wire. Repeat at the jet nozzle end.

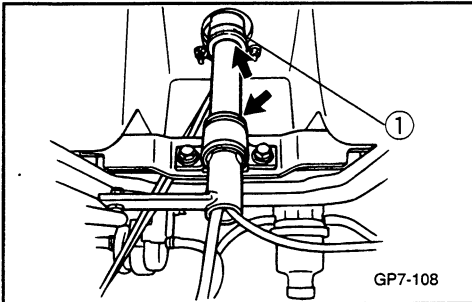

EJU00562

#### Steering handle pivot shaft

After removing the front storage compartment, grease the handle pivot shaft and bushing.

If the steering shaft becomes loose, tighten the band until a satisfactory feel is obtained.

① Band

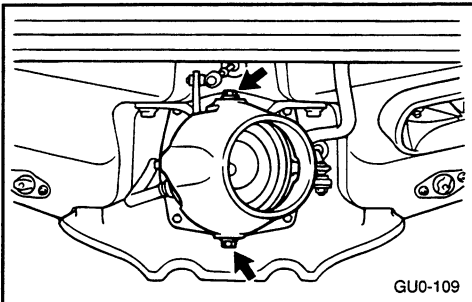

EJU00564

#### Steering nozzle pivot shaft

Grease the steering nozzle pivot shaft collar.





E

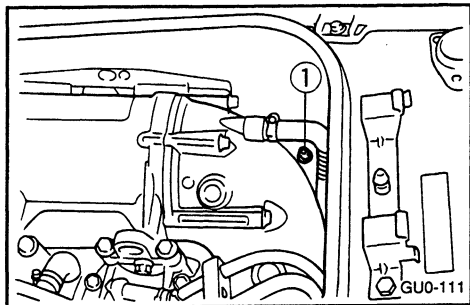

EJU00566

### Bearing housing

- ① Greasing nipple

Grease the bearing housing through the grease nipple.

This service should be done first after 10 hours or 1 month by your YAMAHA dealer.

- Fill the bearing housing with water resistant grease through the grease nipple.

Grease capacity:

33.0~35.0 cc (1.11~1.18 oz)

After first service: Every 100 hours or 6 months (you may do this yourself)

Grease capacity:

6.0~8.0 cc (0.20~0.27 oz)

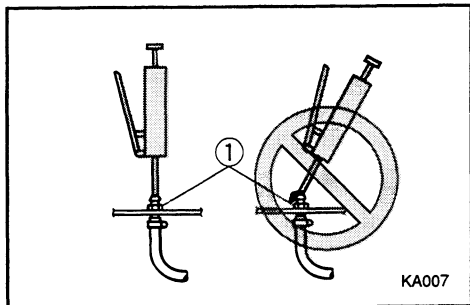

**NOTE:** \_\_\_\_\_

- Fill the grease slowly and carefully, because it can damage the hose and the joints.
- Recommended water resistant grease : YAMAHA grease A or YAMAHA marine grease.



E

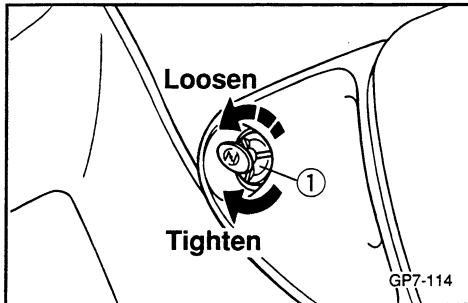

EJU00570

### CHOKE CABLE ADJUSTMENT

Pull the choke knob out until it stops. Release the knob. The knob should not move. If it moves back on its own, tighten the friction adjustment slightly. If the knob is difficult to move, loosen the friction adjustment slightly.

① Adjustment nut

EJU00572

### BATTERY

Check the level of the battery fluid and see if the terminals are tight. Add distilled water if the fluid level is low.

#### **CAUTION:**

**Be careful not to place the battery on its side.**

**When adding the battery fluid or recharging, be sure to bring it out of the battery compartment.**

**When checking the battery, make sure the breather pipe is connected to the battery and not pinched shut by any part of the battery compartment.**



E

**⚠ WARNING**

Battery electrolyte is poisonous and dangerous, causing severe burns, etc. Contains sulfuric acid. Avoid contact with skin, eyes or clothing.

Antidote: EXTERNAL-Flush with water. INTERNAL-Drink large quantities of water or milk. Follow with milk of magnesia, beaten egg or vegetable oil. Call physician immediately.

Eyes: Flush with water for 15 minutes and get prompt medical attention. Batteries produce explosive gases. Keep sparks, flame, cigarettes, etc., away. Ventilate when charging or using in enclosed space. Always shield eyes when working near batteries.

**KEEP OUT OF REACH OF CHILDREN.**

**Replenishing the battery fluid**

A poorly maintained battery will deteriorate quickly. The battery fluid should be checked before every ride.

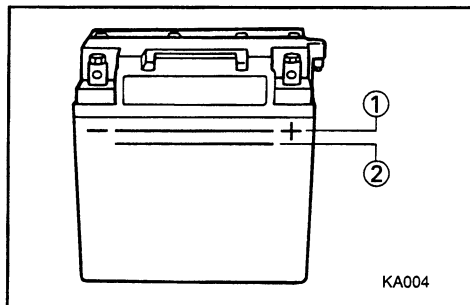

- 1) The level should be between the upper and lower level marks. If refilling is necessary, use only distilled water.

- ① Upper level
- ② Lower level

**CAUTION:**

Normal tap water contains minerals which are harmful to a battery; therefore, refill only with distilled water.



E

### Recharging

#### **⚠ WARNING**

- When charging the battery keep it well away from sparks and open flames, as it gives off explosive gases.
- When using a battery charger, connect the battery to the charger before you turn the charger on. This will prevent sparking at the terminals which could ignite battery gases.

- 1) Remove the caps from the cells. Add distilled water if necessary to top up the electrolyte to the proper level.
- 2) Connect the battery to a charger. Set the charging rate at 1.9 amps, and charge it for 10 hours.

#### **Connecting the battery terminals**

- Always make sure the connections are correct when you insert the battery in the water vehicle. Make sure that the breather pipe is properly connected and that it is not damaged or obstructed. Make sure the battery is securely held in place.

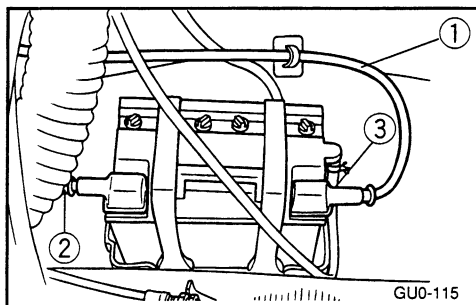

- ① Positive (+) — Red lead
- ② Negative (-) — Black lead
- ③ Breather pipe



E

EJU00573

### CARBURETOR ADJUSTMENT

The carburetor is a vital part of the engine and requires very sophisticated adjustment. Most adjusting should be left to a Yamaha Water Vehicle dealer who has the professional knowledge and experience to do so. However, the following point may be serviced by the owner as part of his usual maintenance routine.

#### CAUTION:

The carburetor was set at the Yamaha factory after many tests. If the settings are disturbed without having technical knowledge, poor engine performance and damage may result.

EJU00577

#### Trolling speed

Place the water vehicle afloat. Start the engine and warm it up for one or two minutes. Using a diagnostic tachometer or, if necessary, the tachometer in the multifunction meter, adjust the engine speed to specification. Turn the throttle stop screw clockwise to increase engine speed or counterclockwise to decrease engine speed.

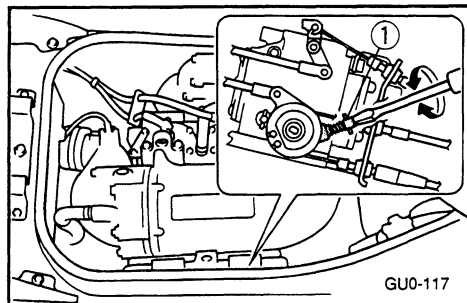

GU0-117

Trolling speed: 1,250~1,350 r/min

① Throttle stop screw

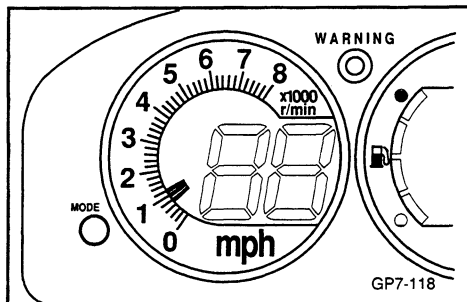

GP7-118

#### NOTE:

- When possible, use a diagnostic tachometer for this procedure.
- When using the tachometer in the multifunction meter, set engine speed as the meter indicates specified trolling speed.



E

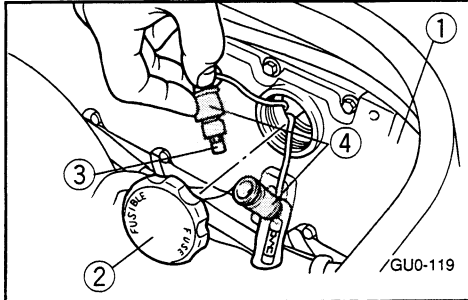

EJU00578

### FUSE REPLACEMENT

The fuse is in the electrical box. To replace the fuse, remove the cap, pull out the red lead, and bring the fuse box out of the electrical box. Open the fuse box and replace the fuse.

- ① Electrical box
- ② Cap
- ③ Fuse (10A)
- ④ Fuse box

### **⚠WARNING**

Do not use fuses of higher amperage than those recommended. Substitution of a fuse of improper rating can cause extensive electrical system damage and possible fire.

EJU00580

### BLEEDING THE OIL INJECTION PUMP

If the oil tank becomes completely empty or any hose connected to oil pump has been disconnected, the oil pump must be bled to ensure proper oil flow.

If bleeding of the oil pump is necessary, take the water vehicle to your nearest Yamaha dealer.



E

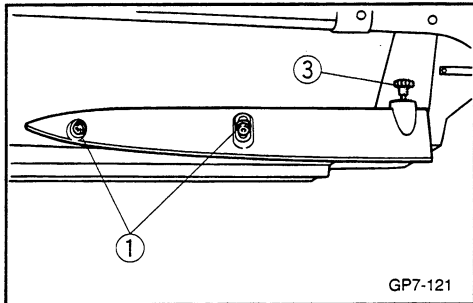

EJU00587

### YAMAHA ADJUSTABLE SPONSON (Y.A.S.) ADJUSTMENT

- 1) Loosen the cap nuts on both sponson.
- 2) Loosen the adjuster lock nut on either sponson. Turn the adjuster to move the sponson up or down to the desired position.

- ① Cap nut
- ② Lock nut
- ③ Adjuster
- ④ Adjustment marks

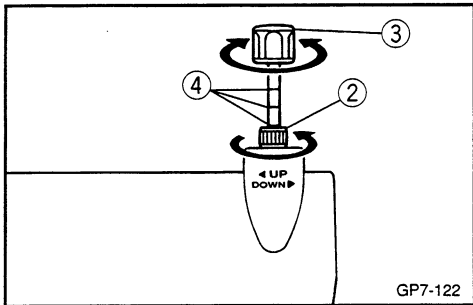

#### CAUTION:

Do not attempt to adjust the sponson without loosening the cap nuts. The adjuster mechanism can be damaged.

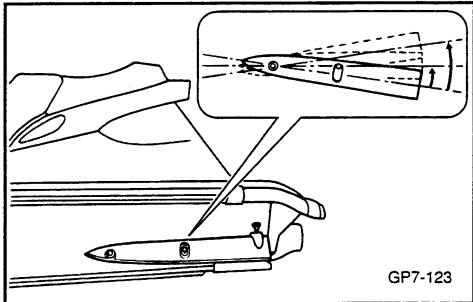

- 3) Tighten the adjuster lock nut. Check the number of marks showing on the shaft of the adjuster, then repeat the adjustment procedure on the other sponson. Both sponsons should be adjusted to the same level.
- 4) Tighten the cap nuts on both sponson securely. Do not overtighten.

Tightening torque:  
13Nm(1.3m•kg, 9.4ft•lb)

#### NOTE:

If a torque wrench is not available, have the cap nuts adjusted to the correct torque as soon as possible with a torque wrench.



E

EJU00588

## SPECIFICATIONS

<b>Item</b>	<b>Model</b>	<b>Unit</b>	<b>GP800</b>
<b>VEHICLE CAPACITY</b>			
Maximum people on board		Number of people	2
Maximum load capacity		kg (lb)	160 (352)
<b>DIMENSIONS</b>			
Length		mm (in)	2,860 (112.6)
Width		mm (in)	1,120 (44.1)
Height		mm (in)	970 (38.2)
Dry Weight		kg (lb)	226 (498)
<b>PERFORMANCE</b>			
Maximum output		kw (PS)/rpm	88.2 (120)/7,000
Maximum fuel consumption		L/h (US gal/h, Imp gal/h)	49 (12.9)
Cruising rang/at full throttle		hr.	1.0
<b>ENGINE</b>			
Engine type			2-stroke
Number of cylinder			2
Displacement		cc (cu.in)	784 (47.84)
Bore & stroke		mm (in)	80 x 78 (3.15 x 3.07)
Compression ratio			6.6
Lubrication system			Oil injection
Cooling system			Water-Cooled
Starting system			Electric starter
Ignition system			Digital
Spark plug		NGK	BR-8ES
Spark plug gap		mm (in)	0.7~0.8 (0.028~0.031)
Battery capacity		V-AH	12-19
Charging system			Flywheel magneto
<b>DRIVE UNIT</b>			
Propulsion system			Jet pump
Jet pump type			Axial flow, single stage
Impeller rotation			Counter clockwise (Rear view)
Transmission			Direct drive from engine
Steering (nozzle) angle			23°±1°
<b>FUEL AND OIL</b>			
Fuel			Unleaded regular gasoline
Recommended engine oil			Minimum octane rating : PON 86/RON 90 YAMALUBE 2 STROKE OUTBOARD OIL, or an equivalent TC-W3 certified
Fuel tank capacity		L (US gal, Imp gal)	50 (13.2,11)
Oil tank capacity		L (US gal, Imp gal)	Including 8.8 (2.32,1.94) reserve 4.0 (1.06, 0.88)



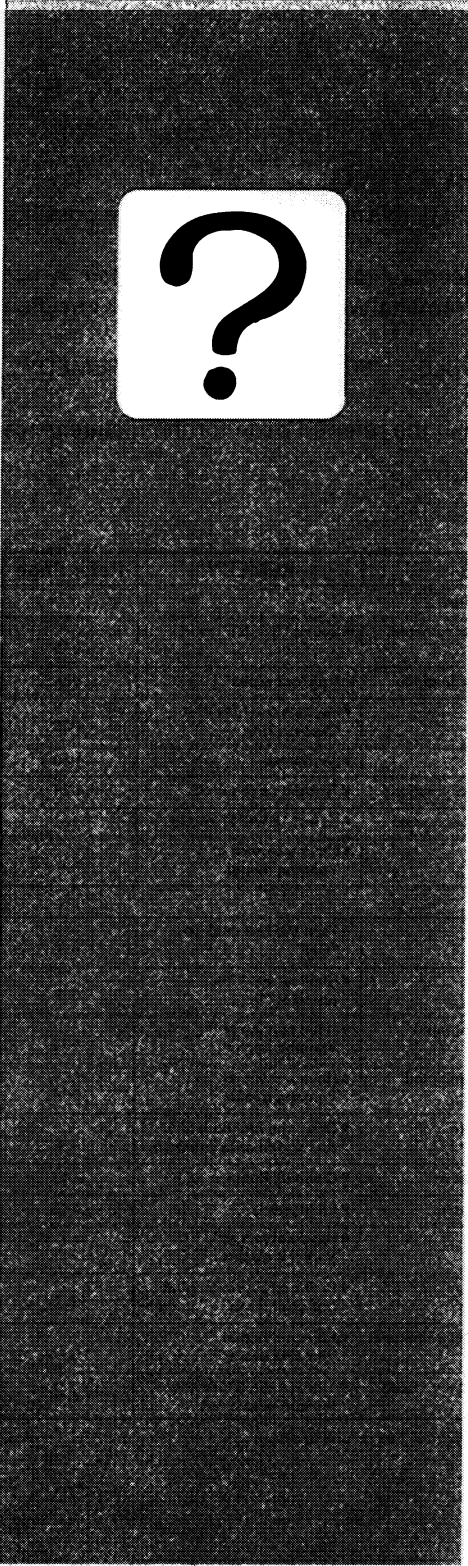

E

EJU00594

# Chapter 5 TROUBLESHOOTING AND EMERGENCY PROCEDURE

**TROUBLESHOOTING** .....5-1  
 Troubleshooting chart.....5-1

**EMERGENCY PROCEDURES** .....5-3  
 Cleaning the jet intake  
 and impeller.....5-3  
 Connecting jumper cables .....5-4  
 Towing the water vehicle.....5-6  
 Submerged water vehicle .....5-7



EJU00595

### TROUBLESHOOTING

If any trouble happens on your water vehicle, use this section to check for the possible case.

If you can not find the cause, or if the procedure for replacement or repair is not described on this owner's manual, ask your Yamaha Water Vehicle dealer or qualified mechanic for the proper service.

The trouble shooting chart contains "TROUBLE", "POSSIBLE CAUSE", "REMEDY", "REFER PAGE".

Check the possible cause and remedy, and also the referred page for the maintenance steps, to solve the trouble.

EJU00596

### TROUBLESHOOTING CHART

TROUBLE	POSSIBLE CAUSE	REMEDY	Refer Page	
<b>The engine does not start</b>	<b>Starter motor does not turn over</b>			
	• Multifunction meter	"LOCK" mode is selected	• Select "START" mode	2-15
	• Stop switch	Lock plate is not in place	Install lock plate	2-7
	• Fuse	Burned out	• Replace the fuse and Check wiring	4-23
	• Battery	Run down	• Recharge	4-20
		Poor terminal connections	• Tighten as required	4-21
		Terminal is disconnected	• Select "START" mode	—
	• Starter Starter component	Faulty	• Have a service at Yamaha dealer	—
	<b>Starter motor turns over</b>			
	• Fuel cock	OFF position	• Turn the fuel cock to "ON"	2-6
	• Fuel	Empty	• Refill as soon as possible*1	3-1
		Stale or contaminated	• Have service at Yamaha dealer	4-10
	• Fuel tank	Water or dust collected	• Have service at Yamaha dealer	4-10
		Built-up pressure	• Open the fuel tank filler cap and release pressure	2-6
	• Spark Plug	Fouled or defective	• Clean or Replace	4-15
	• Spark Plug cap	Not fitted or loose	• Fit properly	4-15
	• Crankcase	Filled with fuel	• Have service at Yamaha dealer	—
		Filled with water	• Crank engine with plug out until clean	5-7
	• Fuel filter	Clogged or water collected	• Have service at Yamaha dealer	4-11
	• Choke	Knob automatically return	• Tighten the choke cable tension adjust nut	4-19

\*1: Turn the fuel cock to "RES (reserve)" to return to shore.



TROUBLE	POSSIBLE CAUSE		REMEDY	Refer Page
<b>The engine runs irregularly or stalls</b>	● Fuel	Empty	● Refill as soon as possible *1	3-1
		Stale or contaminated	● Have a service at Yamaha dealer	4-10
		Oil and gasoline (petrol) mixture is too rich (for pre-mix model)	● Correct to right mixture (for pre-mix model)	—
	● Choke	Knob is left pulled	● Push it in fully	2-8
	● Fuel Filter	Clogged or water collected	● Have service at Yamaha dealer	4-11
	● Fuel tank	Water or dust collected	● Have service at Yamaha dealer	4-11
	● Spark Plug	Fouled or defective	● Replace	4-15
		Incorrect heat range	● Replace	4-15
		Gap incorrect	● Adjust	4-15
	● Spark Plug cap	Loose	● Fit properly	4-15
		Loose electrical connections	● Tighten or connect properly	—
	● Carburetor	Cracked, torn, or damaged	● Replace	—
		Incorrect idle adjustment	● Adjust idle	4-22
		Clogged	● Have service at Yamaha dealer	—
<b>Warning indicator / symbol blinks</b>	● Fuel level	Empty	● Refill as soon as possible *1	3-1
	● Engine oil level	Empty	● Refill immediately	3-2
		Oil filter clogged	● Clean	4-12
	● Engine overheat	Jet intake clogged*2	● Clean	5-3
	● "VOLT" blinks	Voltage is too low	● Recharge	—
	● Low battery voltage	Battery voltage is too low	● Recharge	4-21
Wrong connection of battery terminal		● Connect properly	4-21	
<b>The water vehicle speeds too slow or loses power</b>	● Cavitation	Jet intake clogged	● Clean	5-3
		Impeller damaged or worn	● Have service at Yamaha dealer	—
	● Engine overheat	Jet intake clogged*2	● Clean	5-3
	● Fuel Filter	Clogged	● Have service at Yamaha dealer	4-11
	● Spark plug	Fouled or defective	● Replace	4-15
		Incorrect heat range	● Replace	4-15
		Gap incorrect	● Adjust	4-15
	● Spark plug caps	Loose	● Fit properly	4-15
	● Fuel	Stale or contaminated	● Have service at Yamaha dealer	4-10

\*1 : Turn the fuel cock to "RES (reserve)" to return to shore.

\*2 : Engine speed will be limited to 3,000 r/min by the overheat warning device.



EJU00597

### EMERGENCY PROCEDURES

EJU00598

#### CLEANING THE JET INTAKE AND IMPELLER

If weeds or debris get caught in the intake or impeller, cavitation can occur, and though the engine speed rises, forward thrust will decrease. If this condition is allowed to continue, the engine will overheat and may seize. If there is any sign that the jet intake or impeller is clogged with weeds or debris, beach the vehicle and check the intake and impeller. Always stop the engine before beaching the vehicle.

**⚠WARNING**

Before attempting to remove weeds or debris from the jet intake or impeller areas, shut off the engine and remove the engine stop switch lock-plate from the stop switch. Severe injury or death could result from coming in contact with the rotating parts of the jet pump.

- 1) Turn the vehicle on its side as shown.

**CAUTION:**

Place a suitable clean cloth or carpeting underneath the vehicle to protect it from abrasions and scratches, and always turn the vehicle over on its port (left) sides. When turning the vehicle on its side, support the front portion so the handlebars cannot be bent or damaged.

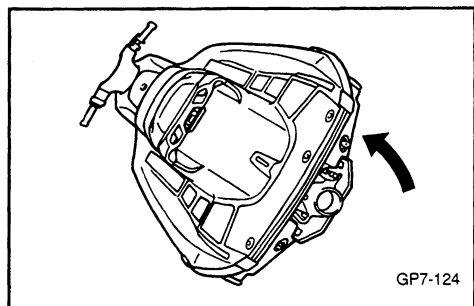
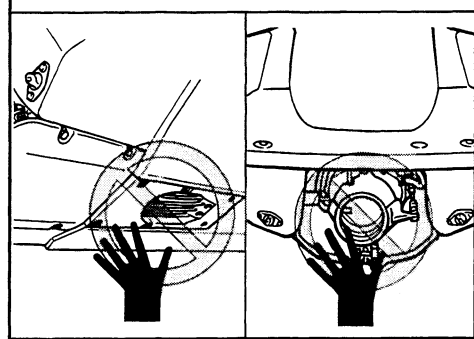
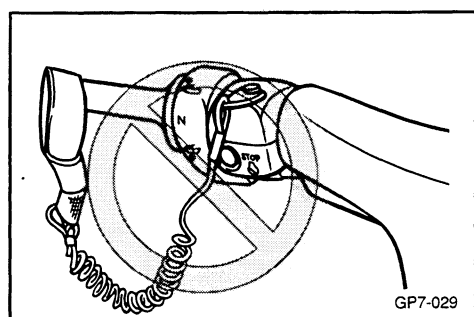



- 2) Remove any weeds or debris from around the drive shaft, impeller, pump housing, and steering nozzle. If it is difficult to remove them, consult your Yamaha Water Vehicle dealer.

**CAUTION:**

Always avoid running your vehicle in areas where weed growth is thick. If traveling in weeded areas is unavoidable, run the engine alternately at partial-throttle and full-throttle. Weeds tend to accumulate more at a steady speed and at trolling speed. If weeds clog the intake or impeller area and cause cavitation, follow the above cleaning procedure.

EJU00599

**CONNECTING JUMPER CABLES**

If the vehicle battery has run down, the engine can be started using a 12-volt battery and jumper cables.

**⚠WARNING**

Battery electrolyte is poisonous and dangerous. It contains sulfuric acid which can cause severe burns. Avoid contact with skin, eyes or clothing.

Antidote: **EXTERNAL**-Flush with water. **INTERNAL**-Drink large quantities of water or milk; follow with milk of magnesia, beaten egg, or vegetable oil. **EYES**-Flush with water for 15 minutes and get prompt medical attention.

Batteries give off explosive gases. Keep sparks, flame, cigarettes, etc. well away. If using or charging the battery in an enclosed area, make sure that it is well ventilated. Always shield your eyes when working near batteries.



E

EJU00600

**To connect the jumper cables**

- 1) Connect the positive (+) terminals of both batteries with the positive (+) jumper cable.
- 2) Connect one end of the negative (-) jumper cable to the negative (-) terminal of the booster battery.
- 3) Connect the other end of the negative (-) cable to an unpainted bolt on the cylinder head.

**CAUTION:** \_\_\_\_\_

**Do not connect the end of the jumper cable to the negative (-) terminal on the vehicle battery! Be sure all connections are secure and correct before attempting to start the engine. Any wrong connection may damage the electrical system.**

- 4) Start the engine, then disconnect the cables by reversing the above steps.

**CAUTION:** \_\_\_\_\_

**Do not turn the starter motor for more than 5 seconds. If the engine does not start in 5 seconds, release the starter switch and try again after 15 seconds. Continuous cranking for more than 5 seconds will discharge the battery and the engine will not start.**

**The starter motor may also be damaged if it is engaged continuously for more than five seconds.**

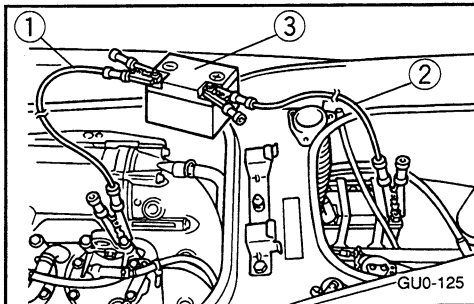

- ① Negative (-) jumper cable
- ② Positive (+) jumper cable
- ③ Booster battery



E

EJU00603

### TOWING THE WATER VEHICLE

If the vehicle becomes inoperative in the water, it can be towed to shore. The bow must be kept up out of the water during towing to prevent water from entering the engine compartment.

If the vehicle must be towed in an emergency using a tow rope, the operator should ride the vehicle, holding onto the handlebars.

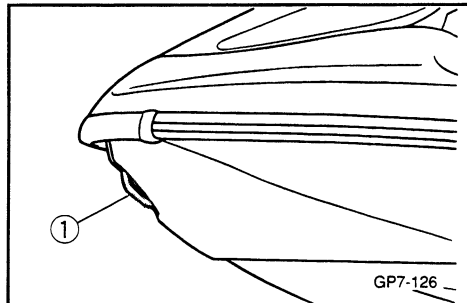

#### CAUTION:

- Tow the water vehicle slowly; water may enter the air intake and flood the engine compartment if the vehicle is towed too fast.
- Tow the vehicle using the bow eye only.

① Bow eye

#### ⚠WARNING

If the water vehicle is towed using a rope:

- The water vehicle should only be towed in an emergency. The towing rope should be long enough so that the water vehicle will not collide with the towing boat when slowing down. A good rule of thumb is a tow rope which is three times the combined length of the towing boat and the water vehicle. A shorter length of rope can be used if the water vehicle is towed very slowly.
- The operator of the towing boat must keep speed to a minimum and avoid traffic or obstacles which could be a hazard to the rider on the water vehicle.



EJU00604

### **SUBMERGED WATER VEHICLE**

If the water vehicle is submerged or flooded with water, follow the procedure below and consult your Yamaha dealer as soon as possible. Failure to do so may result in serious engine damage!

- 1) Beach the vehicle and drain the water from the engine compartment by turning the vehicle on its side. When the water has drained, turn the vehicle upright again.

#### **CAUTION:**

**Turning the water vehicle on its side with the hood open could cause damage to the hood. Use two people to hold the water vehicle by the hull so the handlebars do not touch the ground.**

- 2) Remove the two drain plugs to drain the water. Refer to pages 3-5 "Bilge" for a description of this operation.
- 3) Set the fuel cock to "OFF".
- 4) Remove the spark plugs and dry them with a cloth.
- 5) Without reinstalling the spark plugs, crank the engine until all the water in the cylinders has been drained.
- 6) Reinstall the two drain plugs and the spark plugs.
- 7) Set the fuel cock to "ON".

- 8) Launch the vehicle into the water again and run the engine for at least 10 minutes. If the engine will not start, repeat steps 3~7.
- 9) Turn the engine off. Set the fuel cock to "OFF".
- 10) Remove the cap(s) on the silencer cover and spray a rust inhibitor (such as Yamaha Stor-Rite Engine Fogging Oil) into the carburetor while cranking the engine.
- 11) Have your vehicle inspected by an authorized Yamaha Water Vehicle Dealer as soon as possible.



EJU00608

# Chapter 6 INDEX

INDEX.....6-1

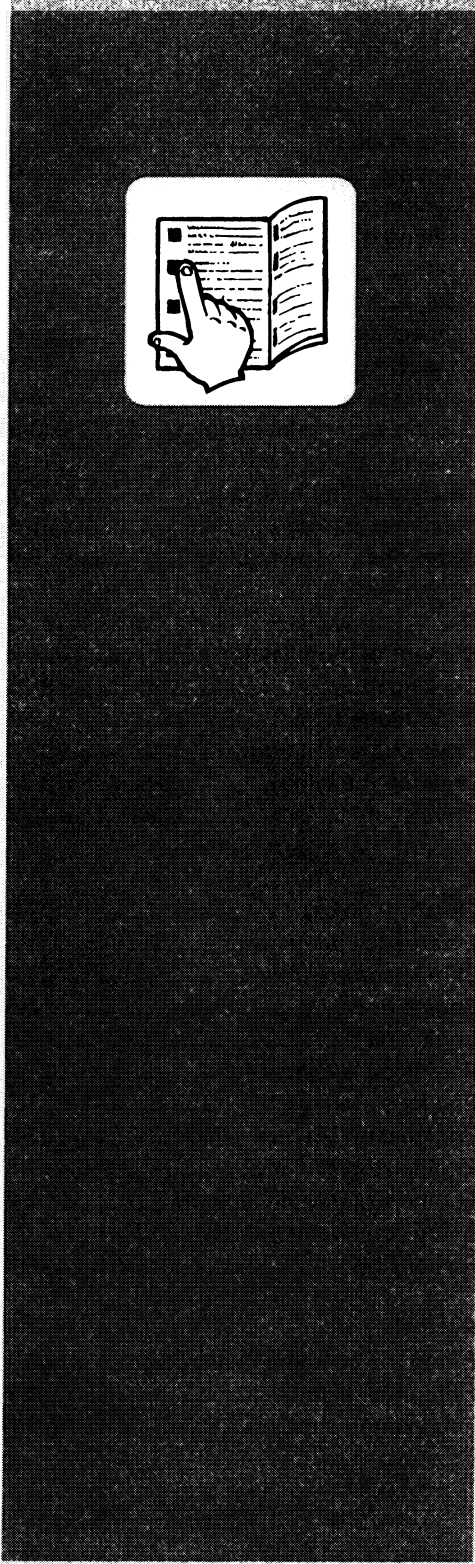



EJU00609

## INDEX

### A

- Age limit.....1-6
- Adjustment and maintenance .....4-7
- Alcohol or drugs .....1-9

### B

- Bad weather operation.....1-7
- Basic skills.....1-7
- Battery .....2-3, 4-5, 4-19
- Battery handling.....4-19
- Beaching .....3-24
- Bearing housing.....4-18
- Bilge.....3-5
- Bilge draining device.....3-27
- Bleeding the oil injection pump .....4-23
- Boarding and starting  
in deep water.....3-19
- Bow eye .....2-1, 5-6
- Brake.....1-11
- Break-in procedure .....3-10

### C

- Capsized water vehicle.....3-22
- Carburetor.....4-22
- Carburetor adjustment.....4-22
- Caution labels.....1-4
- Change of address (warranty) .....6-6
- Check list.....3-3
- Checking battery condition .....3-6
- Checking bilge.....3-5
- Checking fire extinguisher .....3-6
- Checking fuel/oil level.....3-4
- Checking jet intake.....3-8
- Checking water separator .....3-5
- Checking multi function meter.....3-9
- Checking steering moving .....3-7
- Checking switches .....3-8
- Checking throttle moving.....3-7
- Choke cable adjustment.....4-19

- Choke knob.....2-1, 2-8
- Cleaning .....4-6
- Cleaning jet pump.....5-3
- Cleaning the jet intake and impeller .....5-3
- Cleat.....2-1
- Clock.....2-18
- Connecting jumper cables .....5-4
- Connecting the battery terminals.....4-21
- Cooling system flushing .....4-1
- Cooling water pilot outlet.....2-1, 2-9, 3-9
- Crossing rule of the road .....1-12
- Cruising limitations.....1-7
- Customer service .....6-6
- Customer's responsibility .....6-5

### D

- Demerit of modification .....1-9, 4-7
- Docking .....3-25
- Drain plugs .....2-2
- Drain plugs cleaning.....3-5
- Draining the bilge .....3-5, 3-27
- Drive shaft.....2-1

### E

- Electrical box .....2-3
- Emergency procedures .....5-3
- Engine compartment.....3-4
- Engine hood .....2-5
- Engine oil .....1-17
- Engine oil level meter.....2-18
- Engine serial number .....1-1
- Engine stop lanyard switch.....2-2
- Engine stop switch .....2-2, 2-7, 3-8
- Engine stop switch lanyard.....2-2
- Enjoy your water vehicle  
responsibly .....1-16

### F

- Filling the gasoline (petrol) tank.....3-1
- Filling the oil tank.....3-2
- Fire extinguisher .....1-10, 3-6



Fire extinguisher compartment.....	2-1	Hour meter.....	2-19
Flush hose connector.....	2-3, 4-1	Hull identification number (H.I.N.) .....	1-1
Flushing the engine .....	4-1	<b>I</b>	
Flushing the hull .....	4-6	Identification number records .....	1-1
Fogging.....	4-3	Important labels.....	1-2
Footrest floor.....	2-1	Intake grille .....	2-1
Front hood.....	2-1	<b>J</b>	
Front Seat.....	2-1, 2-4	Jet intake.....	1-11, 2-1, 5-3
Front storage compartment .....	2-1, 2-22	Jet nozzle .....	2-2
Fuel and engine oil .....	3-4	Jet propulsion .....	1-11
Fuel cock.....	1-11, 2-1, 2-6	Jet pump cover .....	2-1
Fuel stabilizer, conditioner.....	4-5	Jumps.....	1-7
Fuel filter.....	2-3, 4-11	<b>L</b>	
Fuel level warning indicator .....	2-20	Learning to ride your water vehicle.....	3-16
Fuel level meter.....	2-17	Limit engine running on land.....	3-26, 4-2
Fuel requirements.....	1-17	Limit of starter motor	
Fuel system .....	3-4, 4-5	running period .....	3-14, 5-5
Fuel system inspection.....	4-10	Limitations on who may operate	
Fuel tank .....	2-3, 4-11	the vehicle.....	1-6
Fuel tank capacity .....	3-1	Load capacity .....	1-6, 3-21
Fuel tank filler cap.....	2-1, 2-6	Load limit.....	3-21
Fuse .....	4-23	Location of labels.....	1-2
Fuse box.....	4-23	Location of main components.....	2-1
Fuse replacement.....	4-23	Lock-plate .....	2-2, 2-7
<b>G</b>		Lock-plate attached to the lanyard.....	3-12
Garden hose adapter.....	4-1	Low battery voltage.....	2-21
Gasoline (Petrol) .....	1-17	Lubrication.....	4-3
Gasoline (Petrol) and engine		<b>M</b>	
oil filling .....	3-1	Meeting rule of the road .....	1-13
General exclusions from warranty .....	6-5	Muffler box .....	2-3
Getting to know your water vehicle.....	3-16	Multifunction meter .....	2-2, 2-13, 3-9
Grease .....	4-16	<b>N</b>	
Greasing nipple.....	4-18	Night operation .....	1-7
Greasing points.....	4-16	<b>O</b>	
<b>H</b>		Obtaining repairs under warranty.....	6-5
Handgrips .....	2-12		
Handle bars.....	2-1		
Hazard information.....	1-12		
High tension cord.....	2-3		



**E**

Oil filter.....	4-12	Quick shift trim system controller.....	2-2
Oil filter cleaning.....	4-12	Quick shift trim system mechanism	
Oil injection system inspection.....	4-12	inspection.....	4-14
Oil level warning indicator.....	2-21		
Oil pump cable.....	4-16		
Oil tank.....	2-3, 4-12		
Oil tank capacity.....	3-2		
Operating far from shore.....	1-7		
Operating in overheating.....	2-11		
Operation of controls and			
other functions.....	2-4		
Operation.....	3-10		
Operational requirements.....	1-7		
Other labels.....	1-5		
Other special situations of the rule.....	1-14		
Overheat warning indicator.....	2-21		
Overheat warning system.....	2-11		
Overtaking rule of the road.....	1-14		
Owner's manual and tool kit.....	4-8		
<b>P</b>			
PADLOC.....	2-13		
PADLOC Initial setting.....	2-14		
Period of warranty.....	6-5		
Periodic inspection chart.....	4-9		
Personal Watercraft Industry			
Association (PWIA).....	1-16		
Personal Watercraft Riders			
Association (PWRA).....	1-16		
Physical condition.....	1-9		
Post-operation checks.....	3-26		
Pre-operation checks.....	3-3		
Pre-operation check point.....	3-4		
Pre-operation check list.....	3-3		
Primary identification number.....	1-1		
Protective apparels.....	1-8		
<b>Q</b>			
Quick shift trim system.....	2-2, 2-10		
Quick shift trim system cable joint and			
inner wire.....	4-17		
<b>R</b>			
Read owner's manual.....	1-6		
Rear seat.....	2-1, 2-4		
Recharging battery.....	4-21		
Replenishing the battery fluid.....	4-20		
Riding style.....	1-8		
Riding with a passenger.....	3-17		
Riding your water vehicle.....	3-16		
Rope holes.....	2-1		
Rough water operation.....	3-25		
Rules of the road.....	1-12		
Rules when encountering vessels.....	1-13		
Rust inhibitor.....	3-27		
<b>S</b>			
Safety information.....	1-6		
Seat.....	2-1, 2-4		
Seat latch.....	2-1, 2-4		
Seat storage compartment.....	2-1, 2-23		
Selecting "LOCK" mode.....	2-15		
Selecting "START" mode.....	2-15		
Shallow water operation.....	1-7		
Shift lock release lever.....	2-10		
Silencer cover.....	2-3		
Solo.....	3-19		
Spark plug.....	2-3, 4-15		
Spark plug cleaning and adjustment.....	4-15		
Spark plug gap.....	4-15		
Spark plug torque.....	4-15		
Spark plug type.....	4-15		
Specific parts excluded			
from warranty.....	6-5		
Specifications.....	4-25		
Speedometer.....	2-17		
Starter switch.....	2-2, 2-8		
Starting.....	3-18		
Starting from a landing jetty.....	3-18		



Starting in shallow water .....	3-18	<b>U</b>	
Starting the engine .....	3-12	United States Coast Guard .....	1-16
Steering .....	2-9, 3-7	Using lanyard engine stop switch.....	1-10
Steering and sailing rules and sound signals.....	1-12	<b>V</b>	
Steering cable ball joints and inner wire .....	4-16	Ventilating engine compartment .....	3-4
Steering cable inspection.....	4-13	<b>W</b>	
Steering handle pivot shaft.....	4-17	Warning indicators .....	2-20
Steering nozzle pivot shaft.....	4-17	Warning labels .....	1-3
Stopping .....	3-24	Warranty .....	6-5
Stopping the engine .....	3-15	Warranty exclusions.....	6-5
Stop watch.....	2-19	Warranty period .....	6-5
Storage.....	4-1	Warranty question and answers .....	6-6
Storage compartment.....	2-1, 2-22	Warranty repairs .....	6-5
Submerged water vehicle .....	5-7	Water separator .....	2-3, 3-5
Swimmers and traffic .....	1-10	Water vehicle characteristics .....	1-11
Switches.....	3-8	With a passenger (in shallow or deep water) .....	3-20
<b>T</b>		<b>Y</b>	
Tachometer .....	2-16	Yamaha adjustable sponson (Y.A.S.) .....	2-1, 2-23
Throttle.....	3-7	Yamaha adjustable sponson adjustment.....	4-24
Throttle cable adjustment.....	4-13	Yamaha extended service (Y.E.S.) .....	6-7
Throttle cable and choke cable.....	4-16		
Throttle cable inspection.....	4-13		
Throttle lever .....	2-2, 2-8		
Thrust used for turning .....	1-11		
To get more boating safety information .....	1-16		
Tool kit.....	4-8		
Towing rope length .....	5-6		
Towing the water vehicle.....	5-6		
Transfer of warranty.....	6-5		
Transportation.....	3-28		
Trim shifting grip .....	2-10		
Trip meter .....	2-20		
Trolling speed .....	4-22		
Troubleshooting.....	5-1		
Troubleshooting chart.....	5-1		
Turning.....	3-23		

## LIMITED WARRANTY

### YAMAHA MOTOR CORPORATION, U.S.A. WATER VEHICLE LIMITED WARRANTY

Yamaha Motor Corporation is proud of its heritage and reputation for producing products with high standards of quality and workmanship. Product excellence provides the cornerstone for our commitment to customer satisfaction. The Yamaha Water Vehicle Limited Warranty is your assurance of this commitment.

This warranty provides you with protection against the expense of repairs for your water vehicle that are required as a result of defects in materials or workmanship. When maintained and utilized in the prescribed manner, you can count on your Yamaha water vehicle to provide reliable service.

This warranty provides you with specific coverage and notes your responsibilities in maintaining and operating your water vehicle. Please take the time to read and become familiar with this warranty.

**PERIOD OF WARRANTY.** Any new Yamaha water vehicle purchased for pleasure use from an authorized Yamaha water vehicle dealer in the United States, will be warranted against defects in material or workmanship for a period of one (1) year from date of purchase, subject to exclusions noted herein. Any Yamaha Water Vehicle purchased and utilized for commercial applications will be warranted for a period of ninety (90) days from the date of purchase, subject to exclusions noted herein. Replacement parts used in warranty repairs will be warranted for the balance of the applicable warranty period.

The warranty described here applies to water vehicles purchased and registered for use in the United States only. For warranty provisions outside the United States, contact the particular country's local Yamaha distributor.

**OBTAINING REPAIRS UNDER WARRANTY.** During the period of warranty, any authorized Yamaha water vehicle dealer will, free of charge, repair or replace, at Yamaha's option, any parts adjudged defective by Yamaha due to faulty workmanship or material from the factory. All parts replaced under warranty will become the property of Yamaha Motor Corporation, U.S.A.

**CUSTOMER'S RESPONSIBILITY.** Under the terms of this warranty, the customer will be responsible for ensuring that the water vehicle is properly operated, maintained, and stored as specified in the applicable Owner's Manual.

The owner of the water vehicle shall give notice to an authorized Yamaha water vehicle dealer of any and all apparent defects within ten (10) days of discovery and make the vehicle available at that time for inspection and repairs at the dealer's place of business.

**GENERAL EXCLUSIONS FROM WARRANTY.** This warranty will not cover the repair of damage if the damage is a result of abuse or neglect of the product. Examples of abuse and neglect include, but are not limited to:

1. Racing or competition use, modification of original parts abnormal strain.
2. Lack of proper maintenance and off season storage as described in the Owner's Manual, installation of parts or accessories that are not equivalent in design and quality to genuine Yamaha parts.
3. Use of lubricants, oils, and fuel/oil mixtures that are not suitable for water vehicle motor use.
4. Damage as a result of accidents, collisions, contact with foreign materials, or submersion.
5. Growth of marine organisms on motor or hull surfaces.
6. Normal deterioration.
7. Gel coat stress cracks.

**SPECIFIC PARTS EXCLUDED FROM WARRANTY.** Parts replaced due to normal wear or routine maintenance such as oil, spark plugs, fuel filters, impeller and liner, and anodes are not covered by warranty. Charges for transporting the water vehicle to and from an authorized Yamaha water vehicle dealer are excluded from warranty coverage.

**TRANSFER OF WARRANTY.** Transfer of the warranty from the original purchaser to any subsequent purchaser is possible by having the vehicle inspected by an authorized Yamaha water vehicle dealer and requesting the dealer to submit a change of registration to Yamaha Motor Corporation, U.S.A. within ten (10) days of the transfer.

**YAMAHA MOTOR CORPORATION, U.S.A. MAKES NO OTHER WARRANTY OF ANY KIND, EXPRESSED OR IMPLIED. ALL IMPLIED WARRANTIES OF MERCHANTABILITY AND FITNESS FOR A PARTICULAR PURPOSE WHICH EXCEED THE OBLIGATIONS AND TIME LIMITS STATED IN THIS WARRANTY ARE HEREBY DISCLAIMED BY YAMAHA MOTOR CORPORATION, U.S.A. AND EXCLUDED FROM THIS WARRANTY.**

**SOME STATES DO NOT ALLOW LIMITATIONS ON HOW LONG AN IMPLIED WARRANTY LASTS, SO THE ABOVE LIMITATION MAY NOT APPLY TO YOU. ALSO EXCLUDED FROM THIS WARRANTY ARE ANY INCIDENTAL OR CONSEQUENTIAL DAMAGES INCLUDING LOSS OF USE. SOME STATES DO NOT ALLOW THE EXCLUSION OR LIMITATION OF INCIDENTAL OR CONSEQUENTIAL DAMAGES, SO THE ABOVE EXCLUSION MAY NOT APPLY TO YOU.**

**THIS WARRANTY GIVES YOU SPECIFIC LEGAL RIGHTS, AND YOU MAY ALSO HAVE OTHER RIGHTS WHICH VARY FROM STATE TO STATE.**

YAMAHA MOTOR CORPORATION, U.S.A.  
Post Office Box 6555  
Cypress, California 90630

#### WARRANTY QUESTIONS AND ANSWERS

- Q. What costs are my responsibility during the warranty period?
- A. The customer's responsibility includes all costs of normal maintenance services, non-warranty repairs, accident and collision damages.
- Q. What are some examples of "abnormal" strain, neglect, or abuse?
- A. These terms are general and overlap each other in areas. Specific examples include:  
Running the water vehicle out of oil, operating the machine with a broken or damaged part which causes another part to fail, and so on. If you have any specific questions on operation or maintenance, please contact your Yamaha water vehicle dealer for advice.
- Q. Does the warranty cover incidental costs such as transportation due to a failure?
- A. No. The warranty is limited to repair of the water vehicle itself.
- Q. May I perform any or all of the recommended maintenance shown in the Owner's Manual instead of having the dealer do them?
- A. Yes, if you are a qualified mechanic and follow the procedures specified in the Owner's and Service Manual. We do recommend, however, that items requiring special or equipment be done by a Yamaha water vehicle dealer.
- Q. Will the warranty be void or cancelled if I do not operate or maintain my new water vehicle exactly as specified in the Owner's Manual?
- A. No. The warranty on a new water vehicle cannot be "voided" or "cancelled". **However, if a particular failure is caused by operation or maintenance other than as shown in the Owner's Manual, that failure may not be covered under warranty.**
- Q. What responsibility does my dealer have under this warranty?
- A. Each Yamaha water vehicle dealer is expected to:
1. Completely set up each new water vehicle before sale.
  2. Explain the operation, maintenance, and warranty requirements to your satisfaction at the time of sale, and upon your request at any later date. In addition, each Yamaha water vehicle dealer is held responsible for his setup, service and warranty repair work.
- Q. Is the warranty transferable to second owners?
- A. Yes. The remainder of the existing warranty can be transferred upon request. The unit has to be inspected and re-registered by an authorized Yamaha water vehicle dealer for the policy to remain effective.

#### CUSTOMER SERVICE

If your water vehicle requires warranty service, you must take it to any authorized Yamaha water vehicle dealer within the continental United States. Be sure to bring your warranty registration card or other valid proof of the original date of purchase. If a question or problem arises regarding warranty, first contact the owner of the dealership. Since all warranty matters are handled at the dealer level, this person is in the best position to help you. If you are still not satisfied and require additional assistance, please write:

YAMAHA MOTOR CORPORATION U.S.A.  
CUSTOMER RELATIONS DEPARTMENT  
P.O. Box 6555  
Cypress, California 90630

#### CHANGE OF ADDRESS

The federal government requires each manufacturer to maintain a complete, up-to-date list of all first purchasers against the possibility of a safety-related defect and recall. This list is compiled from the purchase registrations sent to Yamaha Motor Corporation, U.S.A. by the selling dealer at the time of your purchase.

If you should move after you have purchased your new water vehicle, please advise us of your new address by sending a postcard listing your Yamaha model name, engine number, dealer number [or dealer's name] as it is shown on your warranty card, your name and new mailing address.

Mail to:

YAMAHA MOTOR CORPORATION, U.S.A.  
P.O. Box 6555  
Cypress, California 90630  
Attention: Warranty Department

This will ensure that Yamaha Motor Corporation, U.S.A. has an up-to-date registration record in accordance with federal law.

## **YAMAHA EXTENDED SERVICE (Y.E.S.)**

Keep your Yamaha protected even after your warranty expires with genuine Yamaha Extended Service (Y.E.S.).

- Y.E.S. is designed and administered by Yamaha Motor Corporation to provide maximum owner satisfaction. You get uninterrupted factory-backed coverage for extra peace of mind.
- Y.E.S. is flexible. You choose the plan that's right for you: 12 months, 24 months, or 36 months beyond your warranty period.
- Y.E.S. is designed and administered by the same Yamaha people who handle your warranty — and it shows in the comprehensive coverage benefits. There are no mileage limitations. Coverage isn't limited to "moving parts" or the "drive train" like many other plans. And Y.E.S. covers manufacturing defects just like the warranty. See the sample contract at your Yamaha dealer to see how comforting uninterrupted factory-backed protection can be.
- You don't have to pay anything for covered repairs. There's no deductible to pay, and repairs aren't "pro-rated." You don't have any "out-of-pocket" expenses for covered repairs.
- In addition, Travel and Recreation Interruption Protection (TRIP) is included at no extra cost. TRIP gives you up to \$150 reimbursement per occurrence for any reasonable expenses you incur because your Yamaha needs covered service: replacement vehicle rental, emergency towing, phone calls, even food and lodging when you are away from home. This superb coverage goes into effect when you purchase Y.E.S., so it applies to any warranty repairs as well as covered repairs during your entire Y.E.S. plan period.
- Y.E.S. coverage is honored at any authorized Yamaha dealer nationwide.
- Y.E.S. coverage is transferrable to a new owner if you sell or trade-in. That can make your Yamaha much more valuable!

This excellent Y.E.S. plan coverage is only available to Yamaha owners like you, and only while your Yamaha is still within the Yamaha Limited Warranty period. So visit your authorized Yamaha dealer to get all the facts. He can show you how easy it is to protect your investment with Yamaha Extended Service.

We urge you to act now. You'll get the excellent benefits of TRIP coverage right away, and you'll rest easy knowing you'll have strong factory-backed protection even after your Yamaha Limited Warranty expires. You can also save money: Y.E.S. costs less within the first 90 days after you buy your Yamaha. See your dealer today!

A special note:

If visiting your dealer isn't convenient, contact Yamaha with your Primary ID number (your engine number). We'll be happy to help you get the Y.E.S. coverage you need.

Yamaha Service Marketing  
P.O. Box 6555  
Cypress, CA 90630  
(714) 761-7631



**YAMAHA EXTENDED SERVICE**





LIBRARY COPY 4/30/2000

**DO NOT REMOVE THIS ITEM FROM  
THE YAMAHA LIBRARY!**

**LIT-18626-03-06**



**GP800W 1998 Owner's  
Manual**

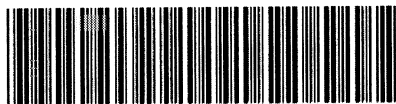

**LIT-18626-03-06**