

Printed in China ◀ WM62610



UB

BLUETOOTH WIRELESS SPEAKER SYSTEM NX-B02 OWNER'S MANUAL

English

IMPORTANT SAFETY INSTRUCTIONS

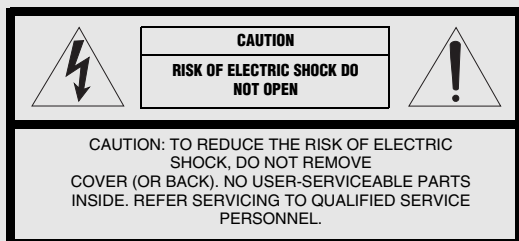

• Explanation of Graphical Symbols



The lightning flash with arrowhead symbol, within an equilateral triangle, is intended to alert you to the presence of uninsulated "dangerous voltage" within the product's enclosure that may be of sufficient magnitude to constitute a risk of electric shock to persons.



The exclamation point within an equilateral triangle is intended to alert you to the presence of important operating and maintenance (servicing) instructions in the literature accompanying the appliance.

IMPORTANT

Please record the serial number of this unit in the space below.

MODEL:

Serial No.:

The serial number is located on the rear of the unit. Retain this Owner's Manual in a safe place for future reference.

- 1 Read these instructions.
- 2 Keep these instructions.
- 3 Heed all warnings.
- 4 Follow all instructions.
- 5 Do not use this apparatus near water.
- 6 Clean only with dry cloth.
- 7 Do not block any ventilation openings. Install in accordance with the manufacturer's instructions.
- 8 Do not install near any heat sources such as radiators, heat registers, stoves, or other apparatus (including amplifiers) that produce heat.
- 9 Do not defeat the safety purpose of the polarized or grounding-type plug. A polarized plug has two blades with one wider than the other. A grounding type plug has two blades and a third grounding prong. The wide blade or the third prong are provided for your safety. If the provided plug does not fit into your outlet, consult an electrician for replacement of the obsolete outlet.
- 10 Protect the power cord from being walked on or pinched particularly at plugs, convenience receptacles, and the point where they exit from the apparatus.
- 11 Only use attachments/accessories specified by the manufacturer.
- 12 Use only with the cart, stand, tripod, bracket, or table specified by the manufacturer, or sold with the apparatus. When a cart is used, use caution when moving the cart/apparatus combination to avoid injury from tip-over.
- 13 Unplug this apparatus during lightning storms or when unused for long periods of time.
- 14 Refer all servicing to qualified service personnel. Servicing is required when the apparatus has been damaged in any way, such as power-supply cord or plug is damaged, liquid has been spilled or objects have fallen into the apparatus, the apparatus has been exposed to rain or moisture, does not operate normally, or has been dropped.



We Want You Listening For A Lifetime

Yamaha and the Electronic Industries Association's Consumer Electronics Group want you to get the most out of your equipment by playing it at a safe level. One that lets the sound come through loud and clear without annoying blaring or distortion - and, most importantly, without affecting your sensitive hearing. Since hearing damage from loud sounds is often undetectable until it is too late, Yamaha and the Electronic Industries Association's Consumer Electronics Group recommend you to avoid prolonged exposure from excessive volume levels. Operate this unit by the following procedure.



COMPLIANCE INFORMATION STATEMENT

(DECLARATION OF CONFORMITY PROCEDURE)

Responsible Party: Yamaha Electronics Corporation, U.S.A.
Address: 6660 Orangethorpe Avenue, Buena Park, CA 90620
Telephone: 714-522-9105
Fax: 714-670-0108
Type of Equipment: BLUETOOTH WIRELESS SPEAKER SYSTEM
Model Name: NX-B02

This device complies with Part 15 of the FCC Rules and RSS-Gen of IC Rules. Operation is subject to the following two conditions:

- 1) this device may not cause harmful interference, and
 - 2) this device must accept any interference, including interference that may cause undesired operation of this device.
- See user manual instructions if interference to radio reception is suspected.

FCC INFORMATION (for US customers)

- 1 **IMPORTANT NOTICE : DO NOT MODIFY THIS UNIT!**
This product, when installed as indicated in the instructions contained in this manual, meets FCC requirements. Modifications not expressly approved by Yamaha may void your authority, granted by the FCC, to use the product.
- 2 **IMPORTANT :** When connecting this product to accessories and/or another product use only high quality shielded cables. Cable/s supplied with this product MUST be used. Follow all installation instructions. Failure to follow instructions could void your FCC authorization to use this product in the USA.
- 3 **NOTE :** This product has been tested and found to comply with the requirements listed in FCC Regulations, Part 15 for Class "B" digital devices. Compliance with these requirements provides a reasonable level of assurance that your use of this product in a residential environment will not result in harmful interference with other electronic devices.
This equipment generates/uses radio frequencies and, if not installed and used according to the instructions found in the users manual, may cause interference harmful to the operation of other electronic devices.

Compliance with FCC regulations does not guarantee that interference will not occur in all installations. If this product is found to be the source of interference, which can be determined by turning the unit "OFF" and "ON", please try to eliminate the problem by using one of the following measures:
Relocate either this product or the device that is being affected by the interference.
Utilize power outlets that are on different branch (circuit breaker or fuse) circuits or install AC line filter/s.
In the case of radio or TV interference, relocate/reorient the antenna. If the antenna lead-in is 300 ohm ribbon lead, change the lead-in to coaxial type cable.
If these corrective measures do not produce satisfactory results, please contact the local retailer authorized to distribute this type of product. If you can not locate the appropriate retailer, please contact Yamaha Electronics Corp., U.S.A. 6660 Orangethorpe Ave, Buena Park, CA 90620.
The above statements apply ONLY to those products distributed by Yamaha Corporation of America or its subsidiaries.

Caution: Read this before operating your unit.

To assure the finest performance, please read this manual carefully. Keep it in a safe place for future reference.

- 1 Install this unit in a well ventilated, cool, dry, clean place - away from direct sunlight, heat sources, vibration, dust, moisture, and/or cold. (Do not use/keep this unit in a car etc.)
- 2 Locate this unit away from other electrical appliances, motors, or transformers to avoid humming sounds.
- 3 Do not expose this unit to sudden temperature changes from cold to hot, and do not locate this unit in an environment with high humidity (i.e. a room with a humidifier) to prevent condensation inside this unit, which may cause an electrical shock, fire, damage to this unit, and/or personal injury.
- 4 Avoid installing this unit where foreign objects may fall onto this unit and/or this unit may be exposed to liquid dripping or splashing. On the top of this unit, do NOT place:
- Other components, as they may cause damage and/or discoloration on the surface of this unit.
- Burning objects (i.e. candles), as they may cause fire, damage to this unit, and/or personal injury.
- Containers with liquid in them, as they may fall and liquid may cause electrical shock to the user and/or damage to this unit.
- 5 Do not cover this unit with a newspaper, tablecloth, curtain, etc. in order not to obstruct heat radiation. If the temperature inside this unit rises, it may cause fire, damage to this unit, and/or personal injury.
- 6 Do not plug this unit into an AC wall outlet until all connections are complete.
- 7 Do not operate this unit upside-down. They may overheat, possibly causing damage.
- 8 Do not use force on switches, knobs, and/or cords.
- 9 When disconnecting the AC adaptor from the wall outlet, grasp the AC adaptor; do not pull the cord.
- 10 Do not clean this unit with chemical solvents; this might damage the finish. Use a clean, dry cloth.
- 11 Only the voltage specified on this unit must be used. Using this unit with a higher voltage than specified is dangerous and may cause fire, damage to this unit, and/or personal injury. Yamaha will not be held responsible for any damage resulting from use of this unit with a voltage other than that specified.
- 12 Do not attempt to modify or fix this unit. Contact qualified Yamaha service personnel when any service is needed. The cabinet should never be opened for any reason.
- 13 When not planning to use this unit for long periods of time (i.e. when going on vacation), disconnect the AC adaptor from the AC wall outlet.
- 14 Be sure to read the "Troubleshooting" section regarding common operating errors before concluding that the unit is faulty.
- 15 Before moving this unit, press power to set this unit to off, and disconnect the AC adaptor from the wall outlet.
- 16 Be sure to use the AC adaptor supplied with this unit. Using an AC adaptor other than the one provided may cause fire or damage to this unit.
- 17 Install this unit near the wall outlet and where the AC adaptor can be reached easily.
- 18 For added protection for this product during a lightning storm, or when it is left unattended and unused for long periods of time, unplug it from the wall outlet. This will prevent damage to the product due to lightning and power-line surges.
- 19 The batteries shall not be exposed to excessive heat such as sunshine, fire or the like.

Special Instructions for U.K. Model

IMPORTANT

THE WIRES IN MAINS LEAD ARE COLOURED IN ACCORDANCE WITH THE FOLLOWING CODE:

Blue: NEUTRAL

Brown: LIVE

As the colours of the wires in the mains lead of this apparatus may not correspond with the coloured markings identifying the terminals in your plug, proceed as follows:

The wire which is coloured BLUE must be connected to the terminal which is marked with the letter N or coloured BLACK. The wire which is coloured BROWN must be connected to the terminal which is marked with the letter L or coloured RED. Making sure that neither core is connected to the earth terminal of the three pin plug.

This equipment complies with FCC/IC radiation exposure limits set forth for uncontrolled equipment and meets the FCC radio frequency (RF) Exposure Guidelines in Supplement C to OET65 and RSS-102 of the IC radio frequency (RF) Exposure rules. This equipment has very low levels of RF energy that it deemed to comply without maximum permissive exposure evaluation (MPE). But it is desirable that it should be installed and operated with at least 20 cm and more between the radiator and person's body (excluding extremities: hands, wrists, feet and ankles).

NOTICE

This equipment has been tested and found to comply with the limits for a Class B digital device, pursuant to part 15 of the FCC Rules. These limits are designed to provide reasonable protection against harmful interference in a residential installation.

This equipment generates, uses and can radiate radio frequency energy and, if not installed and used in accordance with the instructions, may cause harmful interference to radio communications. However, there is no guarantee that interference will not occur in a particular installation. If this equipment does cause harmful interference to radio or television reception, which can be determined by turning the equipment off and on, the user is encouraged to try to correct the interference by one or more of the following measures:

- Reorient or relocate the receiving antenna
- Increase the separation between the equipment and receiver.
- Connect the equipment into an outlet on a circuit different from that to which the receiver is connected.
- Consult the dealer or an experienced radio/TV technician for help.

This unit features a magnetically shielded design, but there is still a chance that placing it too close to a TV set might impair picture color. Should this happen, move this unit away from the TV set.

FOR CANADIAN CUSTOMERS

This Class B digital apparatus complies with Canadian ICES-003.

FCC WARNING

Change or modifications not expressly approved by the party responsible for compliance could void the user's authority to operate the equipment.

This transmitter must not be co-located or operated in conjunction with any other antenna or transmitter.

WARNING

TO REDUCE THE RISK OF FIRE OR ELECTRIC SHOCK, DO NOT EXPOSE THIS UNIT TO RAIN OR MOISTURE.

Thank you for selecting this Yamaha product.

Introduction

◆ 2 way power supply

You can choose one of two power supplies according to your usage circumstances: AC adaptor or batteries.

◆ The Bluetooth wireless technology

By the bluetooth technology, enjoy clear sound with wireless easily.

◆ Real stereo sound

The high quality amplifier, titanium diaphragm and Yamaha's unique SR-BASS technology achieve high quality sound.

◆ PowerStorage™ circuit (High 20 W power)

Yamaha's original power technology enables an impressive 20 W output (Max. Instantaneous Power).

■ Supplied accessories

AC adaptor (DC 12 V, 1 A) 1

The shape of the adaptor may vary depending on the area where you purchased.

China model MU12-2120100-A2

Europe model MU12-2120100-C5

Korea model MU12-2120100-C4

U.K. model MU12-2120100-B2

Controls and functions

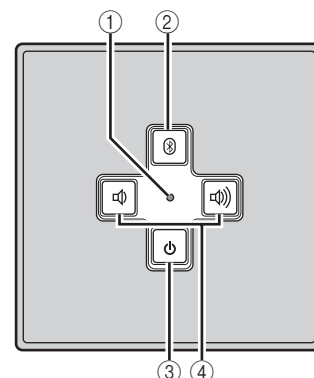

① Status indicator (LED)

Indicates the current status of this unit. For details, refer to "About the status indicator (LED)" on page 2.

② ③ (Bluetooth/Mute button)

Sets this unit to pairing mode to use Bluetooth connection or mutes the sound. To cancel the mute, press ③ again or ②/③. The status indicator flashes during mute.

③ ⏻ (Power button)

Turns this unit on. Press ⏻ again to turn this unit off. When this unit is on, the power indicator lights up in green.

④ ⏮/⏭ (Volume buttons)

Adjust the volume level. Press ⏮ to increase the volume

Connections

Choose one of the two ways of the power supplies and the audio inputs according to your usage circumstances.

Power supplies

1 When using AC Adaptor

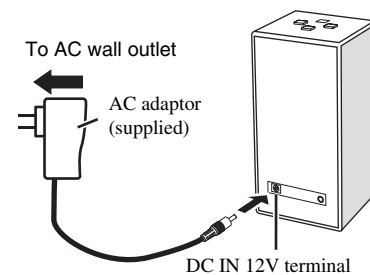

1 Connect the supplied AC adaptor to DC IN 12V terminal at the back of this unit.

2 Plug the AC adaptor to the AC wall outlet.

2 When using batteries

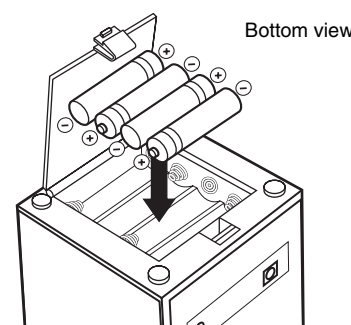

1 Open the battery compartment cover on the bottom of this unit.

2 Insert the 4 commercially available batteries (AA, R6, UM-3) according to the polarity markings (+ and -) on the inside of the battery compartment.

3 Close the battery compartment cover.

Notes

- When the status indicator (LED) does not light even though ϕ is pressed, change all batteries.
- Do not use old batteries and a new ones together.
- Do not use different types of batteries (such as alkaline and manganese batteries) together. Read the packaging carefully because some batteries may be different type even they have the same shape and color.

- When not planning to use this unit for long periods of time (for more than 1 month), remove the batteries from this unit.
- If the batteries have leaked, dispose of them immediately. Avoid touching the leaked material or letting it come into contact with clothing, etc. Clean the battery compartment thoroughly before installing new batteries.
- Do not throw away batteries with general house waste; dispose of them correctly in accordance with your local regulations.

Audio inputs

1 When using Bluetooth connection

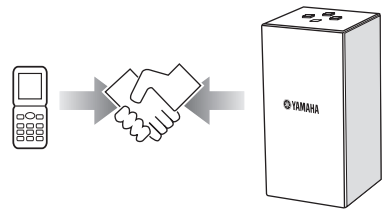

When using Bluetooth, you need to do "pairing". "Pairing" refers to the operation of registering mobile telephones, etc., for Bluetooth communications (hereafter referred to as "other components"). Use the procedure described below to pair.

- Pairing requires operations on this unit and on the other component with which Bluetooth communications are to be established. If necessary, refer to the other component's operating instructions.
- To ensure security, a time limit of 8 minutes is set for the pairing operation. You are recommended to read and fully understand all the instructions before starting.

- 1 Turn on the power of the component you want to pair with.**
- 2 Press ϕ to turn this unit on.**
- 3 Press and hold Ⓜ for more than 4 seconds.**
This device is set to the pairing mode (the status indicator flashes in blue) and your component detects this unit.

4 Select "NX-B02 YAMAHA" or this unit's address from the list of the other component.

The address is indicated on the rear panel of this unit (00 A0 DE 01 xx xx, where "x" is a number from 0 to 9 or a letter from A to F).

5 If you are asked to input a passkey, input the number "0000".

The status indicator flashes quickly, indicating that the pairing process on this unit has been completed. Check that the pairing process on the other component has also been completed. If the status indicator does not flash quickly or if the pairing process on the other component fails, start over from step 3.

Notes

- During Bluetooth communications between this unit and the other component, the pairing mode is not set even though Ⓜ is pressed. Likewise, Bluetooth communications with other components are not possible while in the pairing mode. If the pairing mode is set accidentally, press Ⓜ shortly to cancel the pairing mode.
- This unit can be paired with up to eight other components. When pairing is conducted successfully with a ninth component and the pairing data is registered, the pairing data for the least recently used other component is cleared.
- If the power supply to this unit is cut off during the pairing operation, the pairing data may be damaged. If so, perform the procedure described at "Clearing the pairing data" on page 2 and then perform pairing again.

2 When using analog input

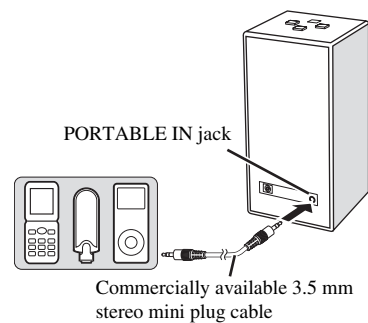

Connect an audio output jack of your portable audio player and the PORTABLE IN jack of this unit using the commercially available 3.5 mm stereo mini plug cable.

Notes

Before connecting, make sure that this unit is turned off.

Using this unit

- 1 Press ϕ to turn this unit on.**
The status indicator (LED) lights up in green.
- 2 Start playback of your Bluetooth device or portable audio player.**
- 3 Adjust the volume level using Ⓜ / Ⓜ .**

Ⓜ
This unit is a stereo speaker. To enjoy the fine sound balance between right and left, face the Yamaha logo to the listening position.

■ After using this unit

- 1 Stop playback of your Bluetooth component or portable audio player.**
- 2 Press ϕ to turn this unit off.**

The status indicator (LED) turns off.

Note

During playback, the Bluetooth connection takes priority over the analog connection.

■ About the status indicator (LED)

LED status	The current status of this unit
Lit in green	This unit is on and playbacks your portable audio player.
Lit in blue	This unit is on and playbacks your Bluetooth component.
Flashing	This unit is muted or in pairing mode.
Flashes once	The volume of this unit is the maximum or minimum.
Off	This unit is off, or power supply is not connected.

Clearing the pairing data

- 1 Press and hold Ⓜ , Ⓜ and Ⓜ , and then press ϕ to turn this unit on.**
The status indicator (LED) flashes in blue.
- 2 Press Ⓜ .**
This unit clears the pairing data.
When clearing finished, the status indicator (LED) lights up in green.

Troubleshooting

If the problem you are experiencing is not listed below, set this unit to off, disconnect the power, and contact the nearest authorized Yamaha dealer or service centre.

General

Problem	Cause	Remedy
No sound.	The connection between this unit and the other component is not correct.	Connect the cable properly.
	The volume is set to the minimum.	Increase the volume level.
	This unit is muted.	Cancel the mute.
The volume level is unstable.	The limiter control has been activated due to excessive input.	Decrease the volume level.

When using the Bluetooth connection

Problem	Cause	Remedy
Cannot make this unit paired with the other component.	The other component is not accepted by this unit.	Check that your component is acceptable with this unit.
	Wrong distance.	Reposition this unit within 10 m (33 ft) range from the other component.
	There is a device (microwave oven, wireless LAN, etc.) outputs signals in the 2.4 GHz frequency band nearby.	Reposition this unit.
	AC adaptor is not connected correctly.	Connect or AC adaptor correctly.
	The power of the connected component is off.	Turn on the connected component.
	The other component does not support A2DP.	Perform the pairing operation with the component which supports A2DP.
No sound is produced, the sound stops or is interrupted during playback.	The other component is not connected to this unit by Bluetooth.	If Bluetooth communications have dropped, reconnect.
	Wrong distance.	Reposition this unit within 10 m (33 ft) range from the other component.
	There is a device (microwave oven, wireless LAN, etc.) outputs signals in the 2.4 GHz frequency band nearby.	Reposition this unit.
	The other component's Bluetooth function is not enabled.	Check that the Bluetooth function of the other component is set properly.
	This unit is not registered on the other component's Bluetooth device list.	Perform the pairing operation again.
	The other component is not set to send Bluetooth audio signals to this unit.	Check that the Bluetooth function of the other component is set properly.
	The output setting of the other component is not set to this unit.	Set the output setting of the other component to this unit.
	The other component's volume is set to the minimum.	Increase the volume level.

Specifications

Speaker type	1-box stereo, Yamaha SR-BASS Technology	Power supply	AC adaptor 12 V/1 A
Driver	45 mm Ti-cone full-range driver x 2	Battery	AA, R6, UM-3 x 4
Input (Analog)	3.5 mm Stereo mini jack	AC to DC adaptor specification	
Bluetooth	Ver. 2.0+EDR Support A2DP profile	Input	AC 100 to 240 V
Dynamic power	6 W x 2 (1 kHz, 6 Ω)	Safety standard	PSE, C-UL, TUV-GS, CCC, EK
Max. instantaneous power*	10 W x 2 (1 kHz, 6 Ω , 10% THD)	Output	12 V DC/1 A
Input sensitivity/Impedance		Power consumption	8 W
Analog input	200 mV/20 k Ω	Dimensions (W x H x D)	84 x 170 x 84 mm (3-5/16" x 6-11/16" x 3-5/16")
Maximum input signal	2.0 V	Weight	600 g (1 lbs. 5 oz.)
Analog input	90 Hz to 20 kHz	*Refers to the power that can be output for 100 ms continuously.	
Frequency response	90 Hz to 20 kHz	Please note that all specifications are subject to change without notice.	

Bluetooth®

- Bluetooth is a technology for wireless communication between devices within an area of about 10 meters (33 ft) employing the 2.4 GHz frequency band, a band which can be used without a license.
- Bluetooth is a registered trademark of the Bluetooth SIG and is used by Yamaha in accordance with a license agreement.

SRBass

"Swing Radiator Bass™" is a trademark of YAMAHA CORPORATION.

PowerStorage™

"PowerStorage™" is a trademark of YAMAHA CORPORATION.

■ Handling Bluetooth communications

- The 2.4 GHz band used by Bluetooth compatible devices is a radio band shared by many types of equipment. While Bluetooth compatible devices use a technology minimizing the influence of other components using the same radio band, such influence may reduce the speed or distance of communications and in some cases interrupt communications.
- The speed of signal transfer and the distance at which communication is possible differs according to the distance between the communicating devices, the presence of obstacles, radio wave conditions and the type of equipment.

Limited Guarantee for European Economic Area (EEA) and Switzerland

Thank you for having chosen a Yamaha product. In the unlikely event that your Yamaha product needs guarantee service, please contact the dealer from whom it was purchased. If you experience any difficulty, please contact Yamaha representative office in your country. You can find full details on our website (<http://www.yamaha-hifi.com/> or <http://www.yamaha-uk.com/> for U.K. resident).

The product is guaranteed to be free from defects in workmanship or materials for a period of two years from the date of the original purchase. Yamaha undertakes, subject to the conditions listed below, to have the faulty product or any part(s) repaired, or replaced at Yamaha's discretion, without any charge for parts or labour. Yamaha reserves the right to replace a product with that of a similar kind and/or value and condition, where a model has been discontinued or is considered uneconomic to repair.

Conditions

- The original invoice or sales receipt (showing date of purchase, product code and dealer's name) MUST accompany the defective product, along with a statement detailing the fault. In the absence of this clear proof of purchase, Yamaha reserves the right to refuse to provide free of charge service and the product may be returned at the customer's expense.
- The product MUST have been purchased from an AUTHORISED Yamaha dealer within the European Economic Area (EEA) or Switzerland.
- The product must not have been the subject of any modifications or alterations, unless authorised in writing by Yamaha.
- The following are excluded from this guarantee:
 - Periodic maintenance and repair or replacement of parts due to normal wear and tear.
 - Damage resulting from:
 - Repairs performed by the customer himself or by an unauthorised third party.
 - Inadequate packaging or mishandling, when the product is in transit from the customer. Please note that it is the customer's responsibility to ensure the product is adequately packaged when returning the product for repair.
 - Misuse, including but not limited to (a) failure to use the product for its normal purpose or in accordance with Yamaha's instructions on the proper use, maintenance and storage, and (b) installation or use of the product in a manner inconsistent with the technical or safety standards in force in the country where it is used.
 - Accidents, lightning, water, fire, improper ventilation, battery leakage or any cause beyond Yamaha's control.
 - Defects of the system into which this product is incorporated and/or incompatibility with third party products.
 - Use of a product imported into the EEA and/or Switzerland, not by Yamaha, where that product does not conform to the technical or safety standards of the country of use and/or to the standard specification of a product sold by Yamaha in the EEA and/or Switzerland.
 - Non AV (Audio Visual) related products.
(Products subject to "Yamaha AV Guarantee Statement" are defined in our website at <http://www.yamaha-hifi.com/> or <http://www.yamaha-uk.com/> for U.K. resident.)
- Where the guarantee differs between the country of purchase and the country of use of the product, the guarantee of the country of use shall apply.
- Yamaha may not be held responsible for any losses or damages, whether direct, consequential or otherwise, save for the repair or replacement of the product.
- Please backup any custom settings or data, as Yamaha may not be held responsible for any alteration or loss to such settings or data.
- This guarantee does not affect the consumer's statutory rights under applicable national laws in force or the consumer's rights against the dealer arising from their sales/purchase contract.