

WaveRunner



**2002
WaveRunner**

XLT800

A blurred, black and white photograph showing a person riding a WaveRunner on the water, creating a sense of motion.

**OWNER'S/OPERATOR'S
MANUAL**

U.S.A. Edition

YAMAHA MOTOR CORPORATION, USA

LIT-18626-04-44●

**READ THIS MANUAL
CAREFULLY BEFORE OPERATION!**

⚠ WARNING

The engine exhaust from this product contains chemicals known to the State of California to cause cancer, birth defects or other reproductive harm.

YAMAHA

LIT-CALIF-65-01

To the owner/operator

Thank you for choosing a Yamaha watercraft.

This Owner's/Operator's Manual contains information you will need for proper operation, maintenance, and care. A thorough understanding of these simple instructions will help you to obtain maximum enjoyment from your new Yamaha. If you have any questions about the operation or maintenance of your watercraft, please consult a Yamaha dealer.

Because Yamaha has a policy of continuing product improvement, this product may not be exactly as described in this Owner's/Operator's Manual. Specifications are subject to change without notice.

This manual should be considered a permanent part of this watercraft and should remain with it even if the watercraft is subsequently sold.

EJU01204

Important manual information:

In this manual, information of particular importance is distinguished in the following ways:



The Safety Alert Symbol means **ATTENTION! BECOME ALERT! YOUR SAFETY IS INVOLVED!**

!WARNING

Failure to follow WARNING instructions could result in severe injury or death to the machine operator, passengers, a bystander, or a person inspecting or repairing the watercraft.

CAUTION:

A CAUTION indicates special precautions that must be taken to avoid damage to the watercraft.

NOTE:

A NOTE provides key information to make procedures easier or clearer.

EJU01173

**WaveRunner XLT800
OWNER'S/OPERATOR'S MANUAL
©2001 by Yamaha Motor Corporation, USA
1st Edition, September 2001
All rights reserved.
Any reprinting or unauthorized use
without the written permission of
Yamaha Motor Corporation, USA
is expressly prohibited.
Printed in USA
P/N LIT-18626-04-44**

CONTENTS



GENERAL AND SAFETY INFORMATION

1



FEATURES AND FUNCTIONS

2

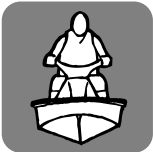

OPERATION

3



MAINTENANCE AND CARE

4



TROUBLESHOOTING AND EMERGENCY PROCEDURES

5



APPENDIX

6

READ THIS OWNER'S/OPERATOR'S MANUAL CAREFULLY BEFORE OPERATING YOUR WATERCRAFT.

GENERAL AND SAFETY INFORMATION



Identification numbers	1-1
Primary Identification (PRI-ID) number	1-1
Hull Identification Number (HIN)	1-1
Engine serial number	1-1
Emission control information	1-2
Approval label of Emission control certificate	1-2
Manufactured date label	1-2
Important labels	1-3
Label location	1-3
Warning labels	1-4
Caution labels	1-6
Other labels	1-7
⚠ Safety information	1-8
Limitations on who may operate the watercraft	1-8
Cruising limitations	1-9
Operation requirements	1-10
Recommended equipment	1-12
Hazard information	1-13
Watercraft characteristics	1-13
Water-skiing	1-14
Rules of the Road	1-16
Steering and sailing rules	1-16
Rules when encountering vessels	1-17
Other special situations	1-18
Reading buoys and other markers	1-18
To get more boating safety information	1-20
United States Coast Guard	1-20
Other sources	1-20
Watercraft Education and Training	1-20
Enjoy your watercraft responsibly	1-21



EJU00994

Identification numbers

Record your Primary Identification (PRI-ID) number, Hull Identification Number (HIN) and engine serial number in the spaces provided, to assist you in ordering spare parts from a Yamaha dealer. Also record and keep these ID numbers in a separate place in case your watercraft is stolen.

EJU00995

Primary Identification (PRI-ID) number

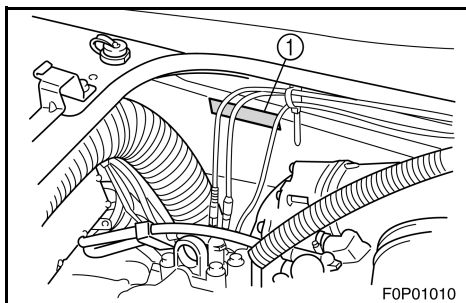

MODEL	XA800A-A	PRI-ID	F1F
YAMAHA MOTOR MANUFACTURING CORPORATION OF AMERICA ASSEMBLED IN U.S.A. FROM AMERICAN AND JAPANESE COMPONENTS. ASSEMBLÉ AUX ÉTATS-UNIS DE PIÈCES AMÉRICAINES ET JAPONAISES.			

F	1	F	-							
---	---	---	---	--	--	--	--	--	--	--

The PRI-ID number is stamped on a label ① attached to the inside of the engine compartment.

EJU01205

Hull Identification Number (HIN)

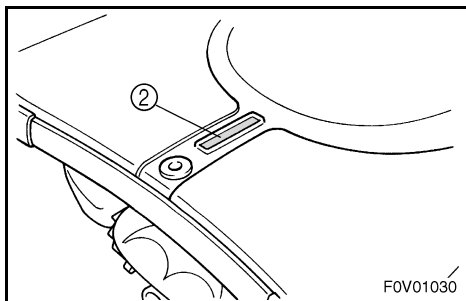

Y	A	M								
---	---	---	--	--	--	--	--	--	--	--

The HIN is stamped on a plate ② attached to the aft deck.

EJU00997

Engine serial number

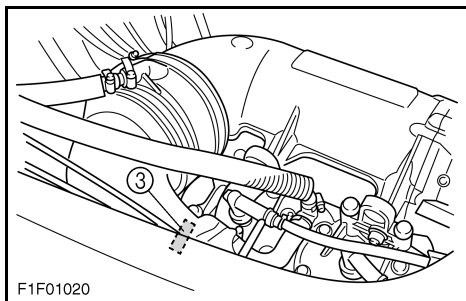

YAMAHA									
YAMAHA MOTOR CO., LTD. MADE IN JAPAN PAYÉ D'ORIGINE JAPON									

The engine serial number is stamped on a label ③ attached to the engine unit.

F1F01020

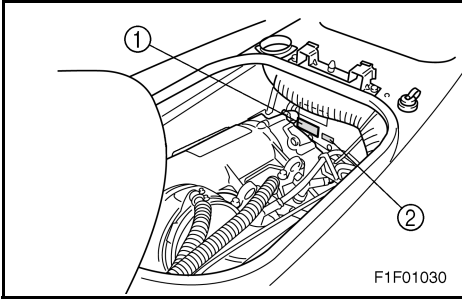

EJU01174

Emission control information

This engine conforms to the U.S. Environmental Protection Agency (EPA) regulations for marine SI engines for the year 2002.

EJU01392

Approval label of Emission control certificate

This label is attached to the electrical box and the exhaust side of the crankcase.

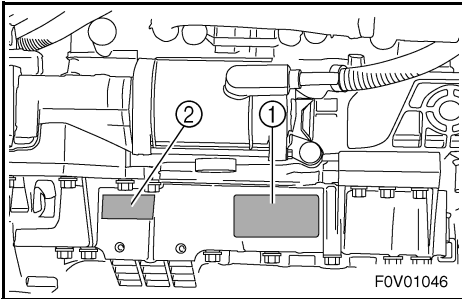

① Emission control information label

EMISSION CONTROL INFORMATION	
ENGINE FAMILY :
THIS ENGINE CONFORMS TO 2002 U.S. EPA REGULATIONS FOR MARINE SI ENGINES.	
FELs : g/kw-hr
SPARK PLUG GAP (mm) :
TROLLING SPEED : rpm
YAMAHA MOTOR CO.,LTD.	

EJU01393

Manufactured date label

This label is attached to the electrical box and the exhaust side of the crankcase.

② Manufactured date label

YAMAHA	
Manufactured:	□ □ □ □ □ □



EJU00998

Important labels

EJU01351

Label location

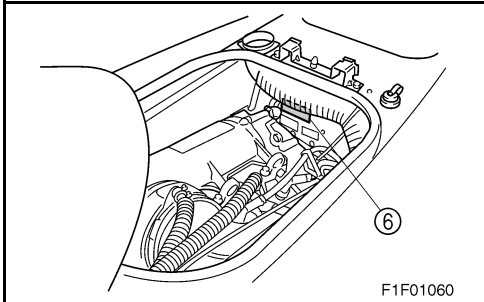
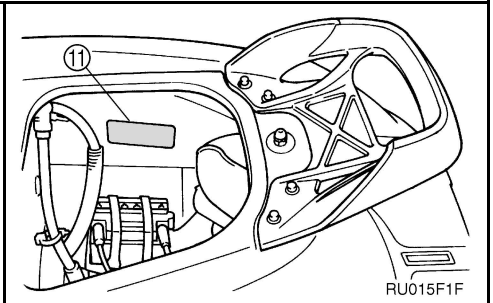
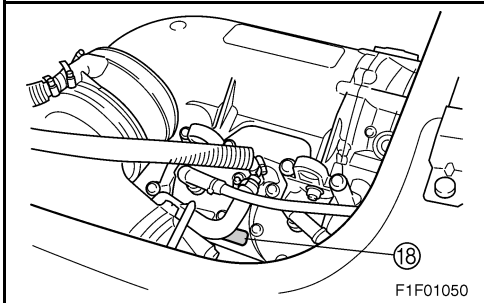
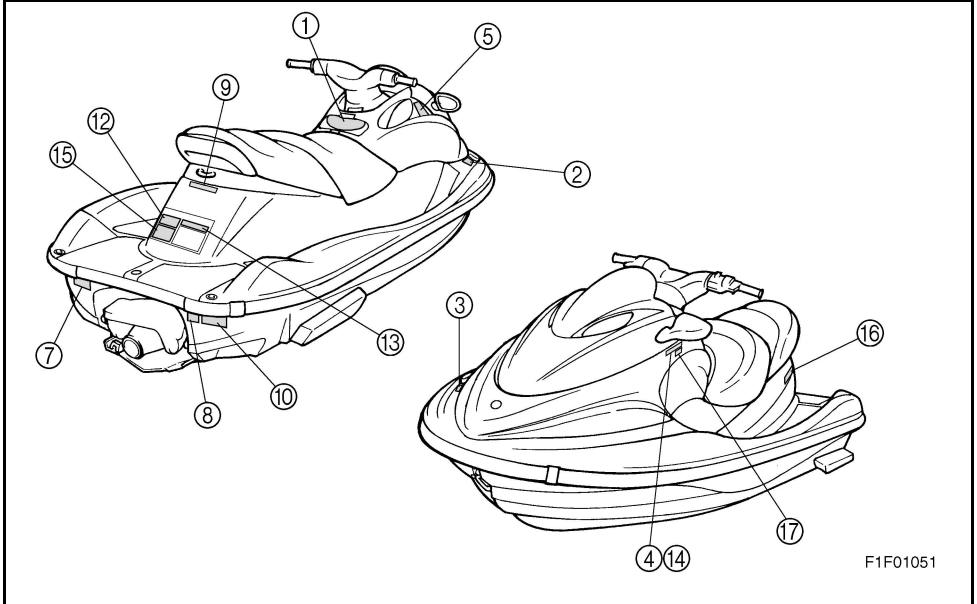

EJU01352

Warning labels

①

WEAR A PERSONAL FLotation DEVICE (PFD). All riders must wear a Coast Guard approved PFD that is suitable for personal watercraft (PWC) use.

WEAR PROTECTIVE CLOTHING. Severe internal injuries can occur if water is forced into body cavities as a result of falling into water or being near jet thrust nozzle. Normal swimwear does not adequately protect against forced water entry into rectum or vagina. All riders must wear a wet suit bottom or clothing that provides equivalent protection (See Owner's Manual). Footwear, gloves, and goggles/glasses are recommended.

KNOW BOATING LAWS. Yamaha Motor Co., Ltd. recommends a minimum operator age of 16 years old. Know the operator age and training requirements for your state. A boating safety course is recommended and may be required in your state.

ATTACH ENGINE SHUT-OFF CORD (LANYARD) to wrist and keep it free from handlebars so that engine stops if operator falls off. After riding, remove cord from PWC to avoid unauthorized use by children or others.

▲ WARNING

To reduce the risk of **SEVERE INJURY** or **DEATH**:

RIDE WITHIN YOUR LIMITS AND AVOID AGGRESSIVE MANEUVERS to reduce the risk of loss of control, ejection, and collision. This is a high performance boat – not a toy. Sharp turns or jumping wakes or waves can increase the risk of back/spinal injury (paralysis), facial injuries, and broken legs, ankles, and other bones. Do not jump wakes or waves.

DO NOT APPLY THROTTLE WHEN ANYONE IS AT REAR OF PWC – turn engine off or keep engine at idle. Water and/or debris exiting jet thrust nozzle can cause severe injury.

KEEP AWAY FROM INTAKE GRATE while engine is on. Items such as long hair, loose clothing, or PFD straps can become entangled in moving parts resulting in severe injury or drowning.

NEVER RIDE AFTER CONSUMING DRUGS OR ALCOHOL.

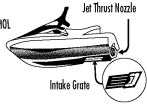
READ AND FOLLOW OWNER'S MANUAL
YAMAHA

FOV-U41B1-41

②

▲ WARNING

Gasoline is highly flammable and explosive. A fire or explosion could cause severe injury or death. Shut engine off. Refuel in well ventilated area away from flames or sparks. Do not smoke. Avoid spilling gasoline. Wipe up spilled gasoline immediately.

REGULAR UNLEADED GASOLINE ONLY

YAMAHA

FOF-U415B-00

③

▲ WARNING

Remove all seats and front storage compartment to ventilate fuel vapors from engine compartment before starting engine. Do not start engine if there is a fuel leak or a loose electrical connection.

YAMAHA

FOF-U418R-00

④

RECOMMENDED OIL

YAMALUBE 2-W or an equivalent TC-W3 certified oil.

YAMAHA

▲ WARNING

Do not add gasoline to oil tank. Fire or explosion could result.

FOM-U41E3-20

⑤

▲ WARNING

REVERSE SHIFT LEVER OPERATION:

- Shift only while engine is idling or off.
- Reverse is for low speed maneuvering only.
- Do not use reverse function to slow down or stop PWC as it could cause you to lose control, be ejected, or impact handlebars.
- Make sure that there are no obstacles or people behind you before shifting to reverse.

FOV-U41D5-20



6

⚠ WARNING

Do not touch or remove electrical parts when starting or running the engine.

YAMAHA

6R7-63623-40

7

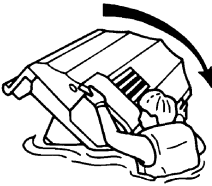

⚠ WARNING

IMPROPER UPRIGHTING CAN CAUSE INJURY.

- Shut engine off, and be sure engine shut-off cord is removed from engine shut-off switch.
- Do not put hand in intake grate.
- Make sure that you are not hit by PWC as it comes over.

TO TURN OVER:

- Pull PWC over with left hand on ride plate while pushing down on gunwale with right hand/foot.

YAMAHA

FOP-U41E1-10

8

⚠ WARNING



Pinch hazard. Stay clear of reverse gate during operation.

YAMAHA

FOP-U416R-03

9

⚠ WARNING

- Severe internal injuries can occur if water is forced into body cavities as a result of being near jet thrust nozzle.
- Wear a wetsuit bottom or clothing that provides equivalent protection.
- Do not board PWC if operator is applying throttle.

YAMAHA

FOP-U41D1-00



EJU01353

Caution labels

10

CAUTION

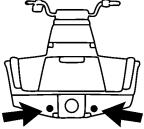

BEFORE LAUNCHING:
See Owner's Manual for draining procedure. Make sure stern drain plugs are tightened securely.

YAMAHA

FOP-U418G-00

11

CAUTION

BATTERY REMOVAL:

- Disconnect both battery leads and battery breather hose before removing battery.

BATTERY INSTALLATION:

- Connect red lead to positive (+) terminal. Connect black lead to negative (-) terminal. Reversing leads will damage electrical system.
- Make sure that breather hose is connected after installation.

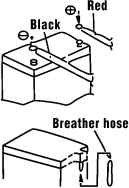

YAMAHA

FOP-U418B-00

12

CAUTION

HANDGRIP IS FOR BOARDING AND SPOTTING ONLY.

Do not use to tow objects, lift PWC, or attach tie downs, otherwise damage could occur.

YAMAHA

(FOP-U41E1-01)

13

CAUTION

- Cleat is for mooring or pulling a water skier.
- Do not use cleat to lift PWC, otherwise damage could occur.

YAMAHA

(FOP-U41E1-01)



EJU01354

Other labels

14

RECOMMENDED OIL	 WARNING
YAMALUBE 2-W or an equivalent TC-W3 certified oil.	Do not add gasoline to oil tank. Fire or explosion could result.
YAMAHA	

F0M-U41E3-20

15

AFTER OPERATION

After removing from water :

- Flush jet pump and hull with fresh water. Remove stern drain plugs.
- Start engine and rapidly squeeze and release throttle lever for 10-15 seconds to drain any water remaining in exhaust system.
- Refer to Owner's Manual for maintenance and storage information.

YAMAHA

(F0P-U41E1-01)

16

RATED PERSON CAPACITY:3

MAXIMUM LOAD:240 Kg (530 lb)

YAMAHA

F0P-U41G1-00

17

FIRE EXTINGUISHER CONTAINER

F0V-U41F5-00

18





EJU01177



Safety information

The safe use and operation of this watercraft is dependent upon the use of proper riding techniques, as well as upon the common sense, good judgment, and expertise of the operator. Every operator should know the following requirements before riding the watercraft.

- Before operating the watercraft, read the Owner's/Operator's Manual, the Riding Practice Guide, the Riding Instruction card and all warning and caution labels on the watercraft. Also, watch the Basic Orientation Video provided with your watercraft. These materials should give you an understanding of the watercraft and its operation.
- Never allow anyone to operate this watercraft until they too have read the Owner's/Operator's Manual, the Riding Practice Guide, the Riding Instruction card and all warning and caution labels, and if possible watched the Basic Orientation Video. Showing them the video may help reinforce the information contained in these materials.

EJU01159

Limitations on who may operate the watercraft

- Yamaha recommends a minimum operator age of 16 years old. Adults must supervise use by minors. Know the operator age and training requirements for your state. A boating safety course is recommended and may be required in your state. You can find local rules by contacting the United States Coast Guard (USCG), the National Association of State Boating Law Administrators, or your local Power Squadron.

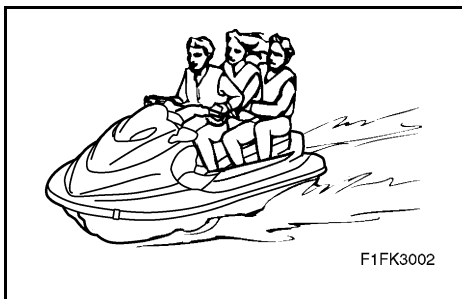

- This watercraft is designed to carry the operator and up to 2 passengers. Never exceed the maximum load limit or allow more than 3 persons (or 2 persons if a water-skier is being pulled) to ride the watercraft at one time.

Maximum load: 240 kg (530 lb)

Load is the total weight of cargo, operator and passengers.

- Do not operate the watercraft with any passengers on board until you have considerable practice and experience riding alone. Operating the watercraft with passengers requires more skill. Take the time to become accustomed to the handling characteristics of the watercraft before trying any difficult maneuvers.



EJU01001

Cruising limitations

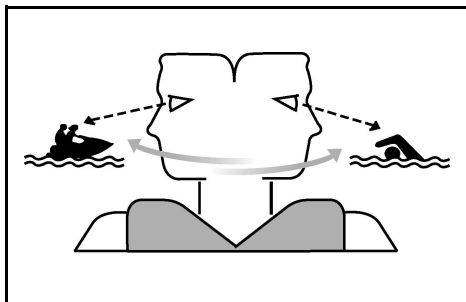

- Scan constantly for people, objects, and other watercraft. Be alert for conditions that limit your visibility or block your vision of others.
- Operate defensively at safe speeds and keep a safe distance away from people, objects, and other watercraft.
- Do not follow directly behind watercraft or other boats.
- Do not go near others to spray or splash them with water.
- Avoid sharp turns or other maneuvers that make it hard for others to avoid you or understand where you are going.
- Avoid areas with submerged objects or shallow water.
- Ride within your limits and avoid aggressive maneuvers to reduce the risk of loss of control, ejection, and collision.
- This is a high performance boat—not a toy. Sharp turns or jumping wakes or waves can increase the risk of back/spinal injury (paralysis), facial injuries, and broken legs, ankles and other bones. Do not jump wakes or waves.

- Do not operate the watercraft in rough water, bad weather or when visibility is poor; this may lead to an accident causing injury or death. Be alert to the possibility of adverse weather. Take note of weather forecasts and the prevailing weather conditions before setting out on your watercraft.
- As with any water sport, you should not ride your watercraft without someone else near by. If you ride further than swimming distance from shore, you should ride by another boat or watercraft, but make sure you stay a safe distance away. It's good common sense!

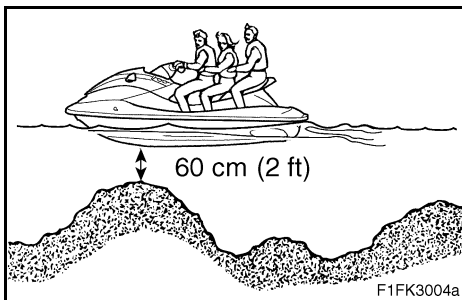

- Never operate in water that is less than 60 cm (2 ft) deep, otherwise you increase your chance of hitting a submerged object, which could result in injury.



- This watercraft is not equipped with lighting required for night operation. Do not operate the watercraft after sunset or before dawn, otherwise you increase the risk of colliding with another boat, which could result in severe injury or death.

EJU01160

Operation requirements

- All riders must wear a Coast Guard approved personal flotation device (PFD) that is suitable for personal watercraft use.
- Wear protective clothing. Severe internal injuries can occur if water is forced into body cavities as a result of falling into water or being near the jet thrust nozzle. Normal swimwear does not adequately protect against forceful water entry into rectum or vagina. All riders must wear a wetsuit bottom or clothing that provides equivalent protection. Such clothing includes thick, tightly woven, sturdy and snug-fitting apparel such as denim, but does not include spandex or similar fabrics, like those used in bicycle shorts.

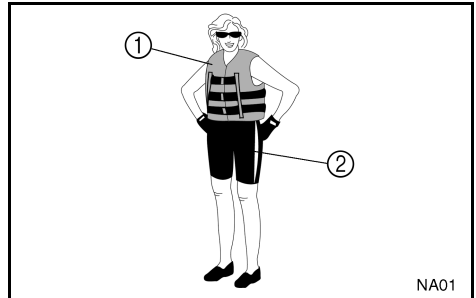

① Coast Guard approved PFD

② Wetsuit bottom

- Eye protection is recommended to keep wind, water, and glare from the sun out of your eyes while you operate your watercraft. Restraining straps for eyewear are made which are designed to float should your eyewear fall in the water. Footwear and gloves are recommended.



- Helmets meeting Snell or DOT standards are required for IJSBA-sanctioned races. You must decide whether to wear a helmet while you ride for recreation. You should know that a helmet could help protect you in certain kinds of accidents and that it could injure you in others.

A helmet is designed to provide some head protection. Although helmets cannot protect against all foreseeable impacts, a helmet might reduce your injuries in a collision with a boat or other obstacle.

A helmet may have potential safety hazards, as well. Falling into the water could risk the chance of the helmet catching water, commonly known as “bucketing,” and the resulting strain on your neck could cause choking, severe and permanent neck injuries, or death. A helmet could also increase the risk of an accident if it reduces your vision or hearing, or if it distracts you or increases your fatigue.

How should you decide if a helmet’s potential safety benefits outweigh its potential risks for you? Consider your particular riding conditions. Consider factors such as your riding environment and your riding style and ability. Also consider the likelihood of traffic congestion, and the water surface conditions. If you decide to wear a helmet based upon your riding circumstances, choose one carefully. Look for a helmet designed for personal watercraft use, if possible. Consider a helmet meeting Snell or DOT standards. If you will be engaging in closed-course competition, follow the helmet requirements of the sanctioning organization.



- NEVER operate the watercraft after consuming alcohol or taking other drugs.
- For reasons of safety and proper care of the watercraft, always perform the pre-operation checks listed on page 3-5 before operating the watercraft.
- The operator and passengers should always keep both feet in the footwell when the watercraft is in motion. Lifting your feet increases your chances of losing your balance, and your feet being hit by objects outside the watercraft. Do not give a ride to children if their feet cannot reach the floor of the footwell.

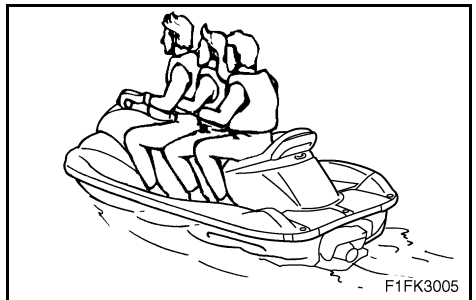

- Passengers should firmly hold on to the person in front of them.
- Always consult your doctor on whether it is safe for you to ride this watercraft if you are pregnant or in poor health.



- Do not attempt to modify this watercraft! Modifications to your watercraft may reduce safety and reliability, and render the watercraft unsafe or illegal for use.

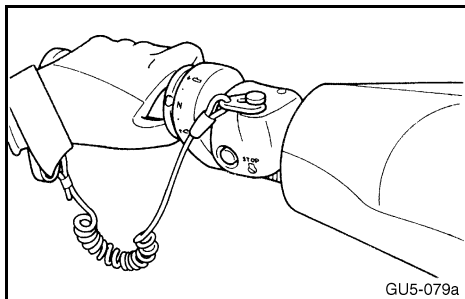

- Attach the engine shut-off cord (lanyard) to wrist and keep it free from the handlebars so that the engine stops if the operator falls off. After riding, remove the engine shut-off cord from the watercraft to avoid accidental starting or unauthorized use by children or others.
- Scan carefully for swimmers and stay away from swimming areas. Swimmers are hard to see and you could accidentally hit someone in the water.
- Avoid being hit by another boat! You should always take the responsibility to watch for traffic; other boaters may not be watching for you. If they do not see you, or you maneuver more quickly than other boaters expect, you risk a collision.
- Maintain a safe distance from other boats or watercraft, and also watch for boats' ski ropes or fishing lines. Obey the "Rules of the Road," and be sure to check behind you before making a turn. (See Rules of the Road on pages 1-16 to 1-19.)

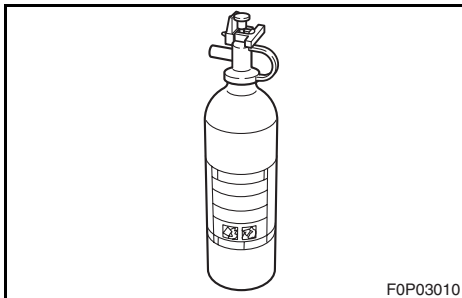

- This watercraft is included in the Class A inboard boat classification of the U.S. Coast Guard. A watercraft of this type **MUST** carry a fire extinguisher of a B-1 classification, with a capacity of two pounds or more when navigating in waters under Coast Guard jurisdiction. In addition, most state and local boating laws also require that the fire extinguisher be approved by the USCG.

EJU01381

Recommended equipment

The following items should be carried on board your watercraft:

- Sound-signaling device
You should carry a whistle or other sound-signaling device that can be used to signal other boats. See Rules of the Road for more information.
- Visual distress signals
It is recommended that a USCG approved pyrotechnic device be stored in a waterproof container on your watercraft. A mirror can also be used as an emergency signal. Contact your Yamaha dealer or the Coast Guard for more information.
- Watch
A watch is helpful so you will know how long you have been operating.
- Towline
A towline can be used to tow a disabled watercraft in an emergency.



EJU01003

Hazard information

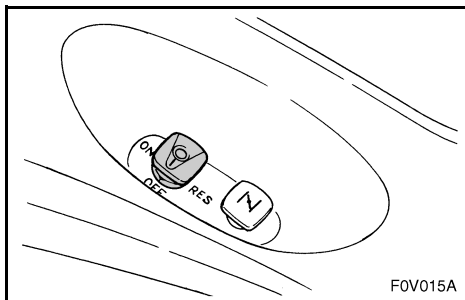

- When transporting or storing your watercraft, always place the fuel cock knob in the “OFF” position, otherwise gasoline may overflow from the carburetor.
- Never start the engine or let it run for any length of time in an enclosed area. Exhaust fumes contain carbon monoxide, a colorless, odorless gas that may cause loss of consciousness and death within a short time. Always operate the watercraft in an open area.

EJU01209

Watercraft characteristics

- Jet thrust turns the watercraft. Releasing the throttle completely produces only minimum thrust. If you are traveling at speeds above trolling, you will have rapidly decreasing ability to steer without throttle. You may still have some turning ability immediately after releasing the throttle, but once the engine slows down, the watercraft will no longer respond to handlebar input until you open the throttle again or you reach a trolling speed. Practice turning in an open area without obstructions until you have a good feel for this maneuver.
- This watercraft are water-jet propelled. The jet pump is directly connected to the engine. This means that jet thrust will produce some movement whenever the engine is running. There is no “neutral” position. You are in either “forward” or “reverse,” depending upon the shift lever position.
- Do not use the reverse function to slow down or stop the watercraft as it could cause you to lose control, be ejected, or impact the handlebars. This could increase the risk of back/spinal injury (paralysis), facial injuries, and broken legs, ankles, and other bones. You could also damage the shift mechanism.



- Reverse can be used to slow down or stop during slow speed maneuvering, such as when docking. Once the engine is idling, shift to reverse and gradually increase engine speed. Make sure that there are no obstacles or people behind you before shifting into reverse.
- Keep away from intake grate ① while the engine is on. Items such as long hair, loose clothing, or PFD straps can become entangled in moving parts resulting in severe injury or drowning.
- Never insert any object into the jet thrust nozzle ② while the engine is running. Severe injury or death could result from coming in contact with the rotating parts of the jet pump.

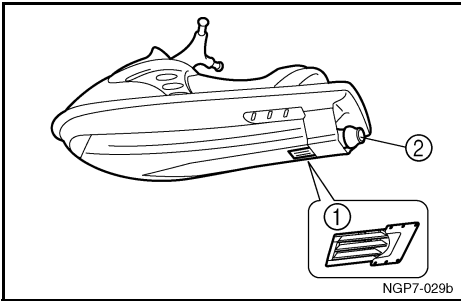

- Stop the engine and remove the clip ③ from the engine shut-off switch ④ before removing any debris or weeds, which may have collected around the jet intake.

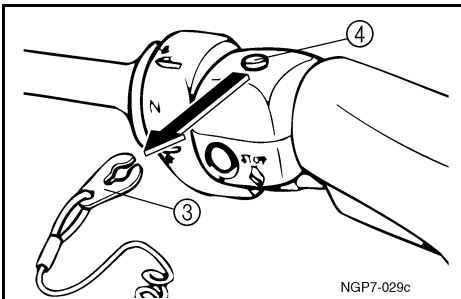

EJU01161

Water-skiing

You can use the watercraft for water-skiing if it has the seating capacity to carry the operator, a rearward-facing spotter, and the water-skier when he or she is not skiing.

The watercraft must also have a cleat ⑤ designed to pull a ski tow rope; do not attach the tow rope to any other location.

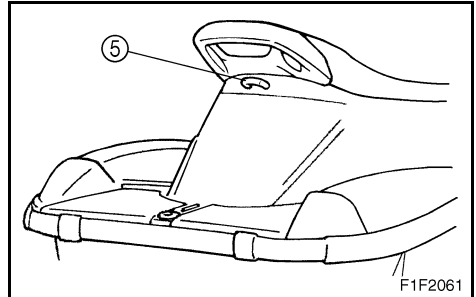

It is the watercraft operator's responsibility to be alert to the safety of the water-skier and others. Know and follow all state and local water-skiing regulations in effect for the waters in which you will be operating.

The operator should be comfortable carrying passengers before attempting to pull a skier.

The following are some important considerations for minimizing risks while water-skiing.

- The skier should wear an approved PFD, preferably a brightly colored one so boat operators can see the skier.
- The skier should wear protective clothing. Severe internal injuries can occur if water is forced into body cavities as a result of falling into the water. Normal swimwear does not adequately protect against forceful water entry into rectum or vagina. The skier should wear a wetsuit bottom or clothing that provides equivalent protection.



- A second person should be on board as a spotter to watch the skier; in most states it is required by law. Let the skier direct the operator's control of speed and direction with hand signals.

The spotter should sit securely on the passenger seat and hold onto the handgrip with feet firmly on the footrest for proper balance while facing to the rear to watch the skier's hand signals and his or her condition.

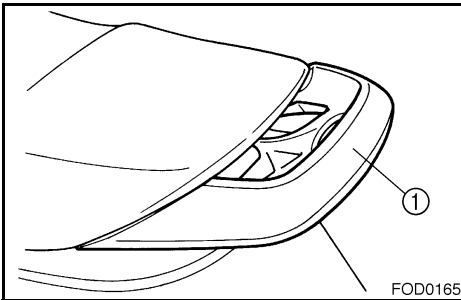
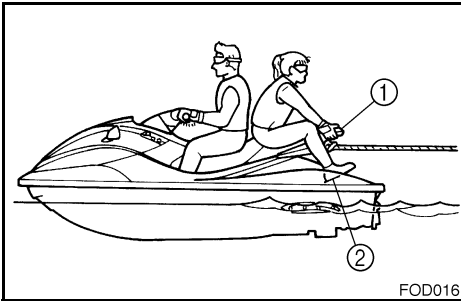

- ① Handgrip
- ② Footrest

- Your control while pulling a skier is affected by the skier's ability, as well as water and weather conditions.

- When preparing to pull a skier, operate the watercraft at the slowest possible speed until the watercraft is well away from the skier and slack in the towrope is taken up. Make sure that the rope is not looped around anything.

After checking that the skier is ready and that there is no traffic or other obstacles, apply enough throttle to raise the skier.

- Make smooth, wide turns. The watercraft is capable of very sharp turns, which could exceed the abilities of the skier. Keep the skier at least 50 m (150 ft), about twice the distance of a standard towrope, from any potential hazard.
- Be alert to the hazard of the towrope handle snapping back at the watercraft when the skier falls or is unable to get up on the skis.
- Towing heavy or bulky objects other than skiers, such as another boat or watercraft, can cause loss of steering control and create a hazardous condition. If you must tow another boat in an emergency situation, operate slowly and cautiously.



Rules of the Road

Yamaha watercraft is legally considered a powerboat. Operation of the watercraft must be in accordance with the rules and regulations governing the waterway on which it is used.

Just as there are rules that apply when you are driving on streets and highways, there are waterway rules that apply when you are operating your watercraft. These rules are used internationally, and are also enforced by the United States Coast Guard and local agencies. You should be aware of these rules, and follow them whenever you encounter another vessel on the water.

Several sets of rules prevail according to geographic location, but are all basically the same as the International Rules of the Road. The rules presented here in this Owner's/Operator's Manual are condensed, and have been provided for your convenience only. Consult your local U.S. Coast Guard Auxiliary or Department of Motor Vehicles for a complete set of rules governing the waters in which you will be operating your watercraft.

Steering and sailing rules

Whenever two vessels on the water meet one another, one vessel has the right-of-way; it is called the "stand-on" vessel. The vessel that does not have the right-of-way is called the "give-way" or "burdened" vessel. These rules determine which vessel has the right-of-way, and what each vessel should do.

Stand-on vessel

The vessel with the right-of-way has the duty to continue its course and speed, except to avoid an immediate collision. When you maintain your direction and speed, the other vessel will be able to determine how best to avoid you.

Give-way vessel

The vessel which does not have the right-of-way has the duty to take positive and timely action to stay out of the way of the stand-on vessel. Normally, you should not cross in front of the vessel with the right-of-way. You should slow down or change directions briefly and pass behind the other vessel. You should always move in such a way that the operator of the other vessel can see what you are doing.

The General Prudential Rule regarding the right-of-way is that if a collision appears unavoidable, neither boat has the right-of-way. Both boats must avoid the collision.

In other words, follow the standard rules except when a collision will occur unless both vessels try to avoid each other. If that is the case, both vessels become give-way vessels.



Rules when encountering vessels

There are three main situations that you may encounter with other vessels which could lead to a collision unless the Steering Rules are followed:

Meeting: you are approaching another vessel head-on

Crossing: you are traveling across another vessel's path

Overtaking: you are passing or being passed by another vessel

In the following illustration, your watercraft is in the center. You should give the right-of-way to any vessels shown in the white area (you are the give-way vessel). Any vessels in the shaded area must yield to you (they are the give-way vessels). Both you and the meeting vessel must alter course to avoid each other.

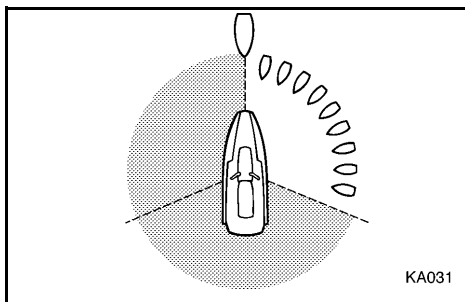

Meeting

If you are meeting another power vessel head on, and are close enough to run the risk of collision, neither of you has the right-of-way! Both of you should alter course to avoid an accident. You should keep the other vessel on your port (left) side. This rule does not apply if both of you will clear one another if you continue on your set course and speed.

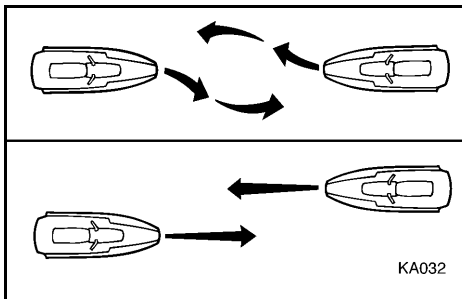

Crossing

When two power-driven vessels are crossing each other's path close enough to run the risk of collision, the vessel which has the other on the starboard (right) side must keep out of the way of the other. If the other vessel is on your starboard (right) side, you must keep out of its way; you are the give-way vessel. If the other vessel is on your port (left) side, remember that you should maintain course and direction, provided the other vessel gives you the right-of-way as it should.

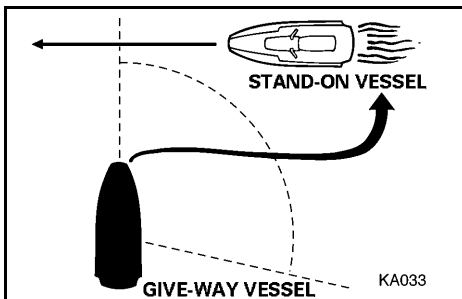



Overtaking

If you are passing another vessel, you are the give-way vessel. This means that the other vessel is expected to maintain its course and speed. You must stay out of its way until you are clear of it. Likewise, if another vessel is passing you, you should maintain your speed and direction so that the other vessel can steer itself around you.

Other special situations

There are three other rules you should be aware of when riding your watercraft around other vessels.

Narrow channels and bends

When navigating in narrow channels, you should keep to the right when it is safe and practical to do so. If the operator of a power-driven vessel is preparing to go around a bend that may obstruct the view of other water vessels, the operator should sound a prolonged blast of four to six seconds on the whistle. If another vessel is around the bend, it too should sound the whistle. Even if no reply is heard, however, the vessel should still proceed around the bend with caution. If you navigate such waters with your watercraft, you will need to carry a portable air horn, available from local marine supply stores.

Fishing vessel right-of-way

All vessels fishing with nets, lines or trawls are considered to be “fishing vessels” under the International Rules. Vessels with trolling lines are not considered fishing vessels. Fishing vessels have the right-of-way regardless of position. Fishing vessels cannot, however, impede the passage of other vessels in narrow channels.

Sailing vessel right-of-way

Sailing vessels should normally be given the right-of-way. The exceptions to this are:

1. When the sailing vessel is overtaking the power-driven vessel, the power-driven vessel has the right-of-way.
2. Sailing vessels should keep clear of any fishing vessel.
3. In a narrow channel, a sailing vessel should not hamper the safe passage of a power-driven vessel that can navigate only in such a channel.

Reading buoys and other markers

The waters of the United States are marked for safe navigation by the lateral system of buoyage. Simply put, buoys and markers have an arrangement of shapes, colors, numbers and lights to show which side of the buoy a boater should pass on when navigating in a particular direction. The markings on these buoys are oriented from the perspective of being entered from seaward (the boater is going towards the harbor). Red buoys are passed on your starboard (right) side when proceeding from open water into the harbor, and black buoys are to your port (left) side. An easy way to remember the meaning of the colors is the phrase “red right returning.” When navigating out of the harbor, your position with respect to the buoys should be reversed; red buoys should be to port and black buoys to starboard.

Many bodies of water used by boaters are entirely within the boundaries of a particular state. The Uniform State Waterway Marking System has been devised for these waters.



This system uses buoys and signs with distinctive shapes and colors to show regulatory or advisory information. These markers are white with black letters and orange borders. They signify speed zones, restricted areas, danger areas, and general information.

Remember, markings may vary by geographic location. Always consult local boating authorities before riding your watercraft in unfamiliar waters.

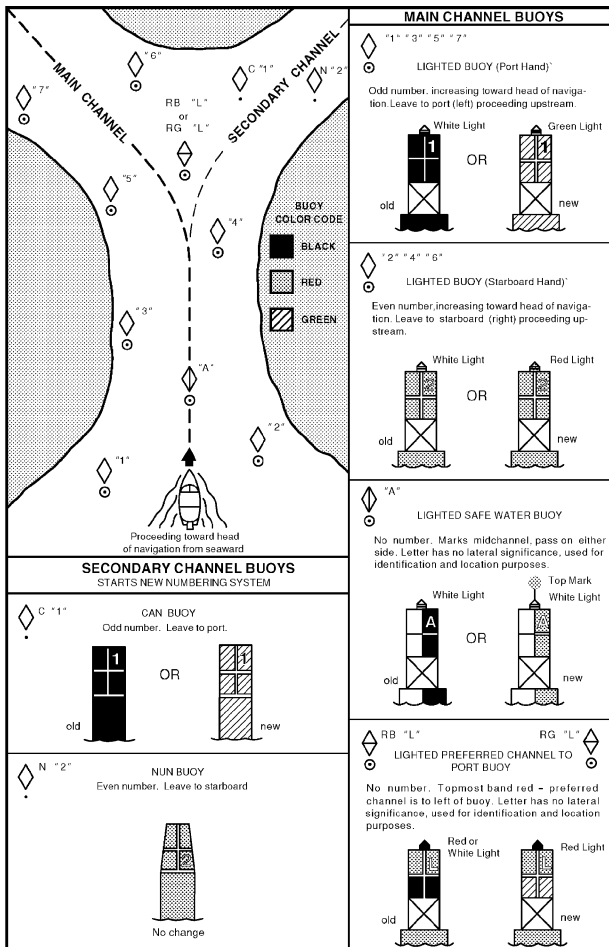

KA034



EJU01181

To get more boating safety information

Be informed about boating safety. Additional publications and information can be obtained from many organizations, including the following.

United States Coast Guard

Consumer Affairs Staff (G-BC)
Office of Boating, Public, and Consumer Affairs
U.S. Coast Guard Headquarters
Washington, D.C. 20593-0001
Boating Safety Hotline: 1-800-368-5647

Other sources

You can find local rules by contacting the National Association of State Boating Law Administrators, or your local Power Squadron.

Watercraft Education and Training

The Online Boating Safety Course, available through the watercraft section of the yamaha-motor.com website, is a free, 50 question learning course available to the public. Upon successful completion of 80 percent or better, the user can request a certificate of completion by mail or can download one immediately. The Online Boating Safety Course, provided by the Boat/US Foundation, is approved by the National Association of State Boating Law Administrators (NASBLA) and recognized by the United States Coast Guard. This course meets the education requirement for those states that recognize non-proctored, NASBLA-approved courses.

Yamaha is the watercraft industry's leading manufacturer to build awareness and support for boating education. In 1997, Yamaha launched its GET W.E.T. (Watercraft Education and Training) initiative and has since reached out to over one million Americans promoting the benefits of boating education.

The Online Boating Safety Course:
<http://www.boatus.com/onlinecourse/>



EJU01006

Enjoy your watercraft responsibly

You share the areas you enjoy when riding your watercraft with others and with nature. So your enjoyment includes a responsibility to treat these other people, and the lands, waters, and wildlife with respect and courtesy.

Whenever and wherever you ride, think of yourself as the guest of those around you. Remember, for example, that the sound of your watercraft may be music to you, but it could be just noise to others. And the exciting splash of your wake can make waves others won't enjoy. Avoid riding close to shoreline homes and waterfowl nesting areas or other wildlife areas, and keep a respectful distance from fishermen, other boats, swimmers, and populated beaches. When travel in areas like these is unavoidable, ride slowly and obey all laws.

Remember that pollution can be harmful to the environment. Do not refuel or add oil where a spill could cause damage to nature. Remove your watercraft from the water and move it away from the shoreline before refueling. And keep your surroundings pleasant for the people and wildlife that share the waterways: don't litter!

When you ride responsibly, with respect and courtesy for others, you help ensure that our waterways stay open for the enjoyment of a variety of recreational opportunities.

FEATURES AND FUNCTIONS



Location of main components2-1

Operation of controls and other

functions	2-5
Rear seat	2-5
Front seat	2-6
Hood	2-7
Fuel tank filler cap	2-8
Oil tank filler cap	2-8
Fuel cock knob	2-9
Engine stop switch	2-10
Engine shut-off switch	2-10
Choke knob	2-10
Throttle lever	2-11
Start switch	2-11
Cooling water pilot outlet	2-12
Steering system	2-12
Tilt lever	2-13
Shift lever	2-14
Quick Shift Trim System (QSTS)	
selector	2-15
Handgrip	2-16
Engine overheat warning system	2-17
Multifunction meter	2-18
PADLOC (Programmable digital	
locking ignition)	2-19
Tachometer	2-21
Speedometer	2-22
Fuel meter	2-22
Engine oil meter	2-23
Clock	2-23
Hour meter	2-24
Trip timer	2-24
Tripmeter	2-25
Fuel warning indicator	2-25
Oil warning indicator	2-26
Engine overheat warning	
indicator	2-26
Battery warning indicator	2-26
Storage compartments	2-27



EJU01008

Location of main components

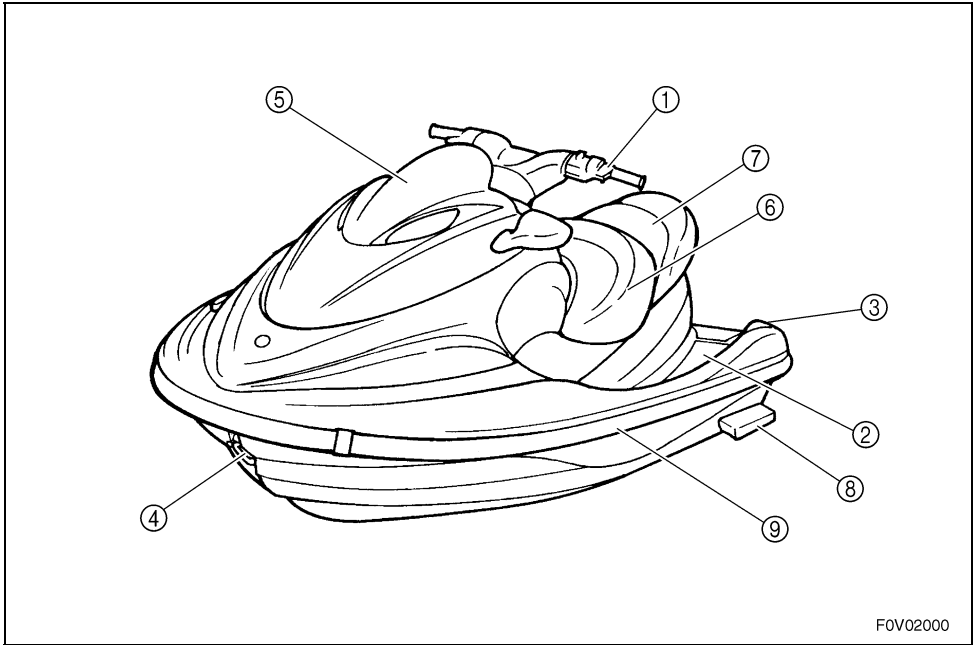

F0V02000

- ① **Handlebars**
Use to control direction.
- ② **Footwell**
Use to place feet for balance.
- ③ **Footrest**
To keep proper balance while facing to the rear to watch the skier.
- ④ **Bow eye**
Use to attach rope for transporting, mooring or towing the watercraft in an emergency.
- ⑤ **Hood**
- ⑥ **Front seat**
- ⑦ **Rear seat**
- ⑧ **Sponsons**
- ⑨ **Gunwale**

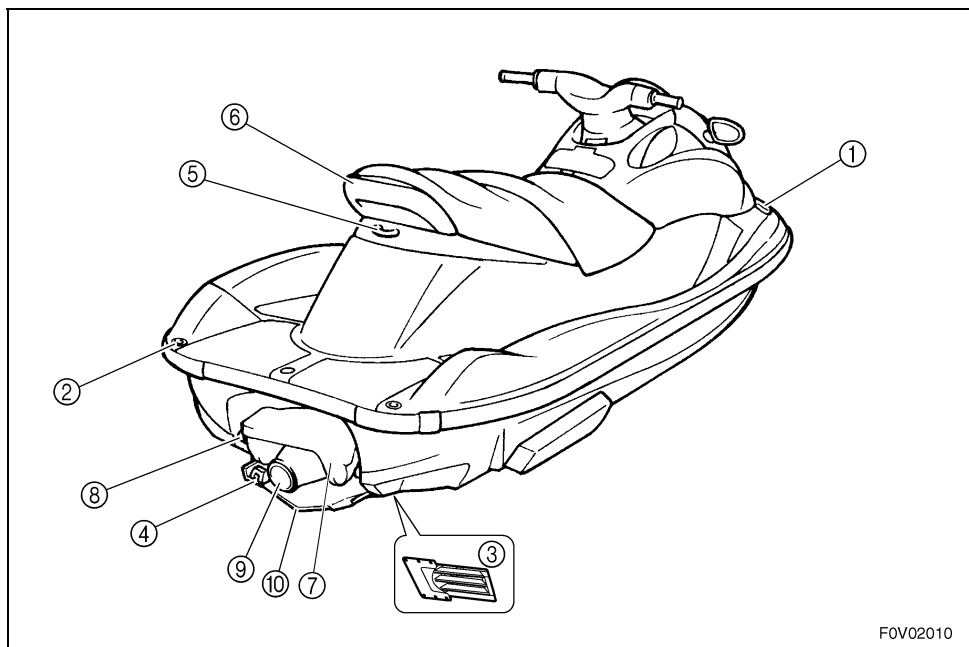

FOV02010

- ① **Fuel tank filler cap**
- ② **Rope holes**
- ③ **Intake grate**
Prevents debris from getting into the jet pump.
- ④ **Speed sensor**
- ⑤ **Cleat**
Use to attach a towrope for pulling water-skier, or a rope for mooring the watercraft.
- ⑥ **Handgrip**
Use for support when boarding the watercraft or when seated facing rearward and acting as a spotter for a water-skier.
- ⑦ **Reverse gate**
Controls direction of jet thrust when in reverse.
- ⑧ **Stern drain plugs**
Use to drain water in the bilge when the watercraft is on dry land.
- ⑨ **Jet thrust nozzle**
Changes the direction of jet thrust according to handlebar position.
- ⑩ **Ride plate**

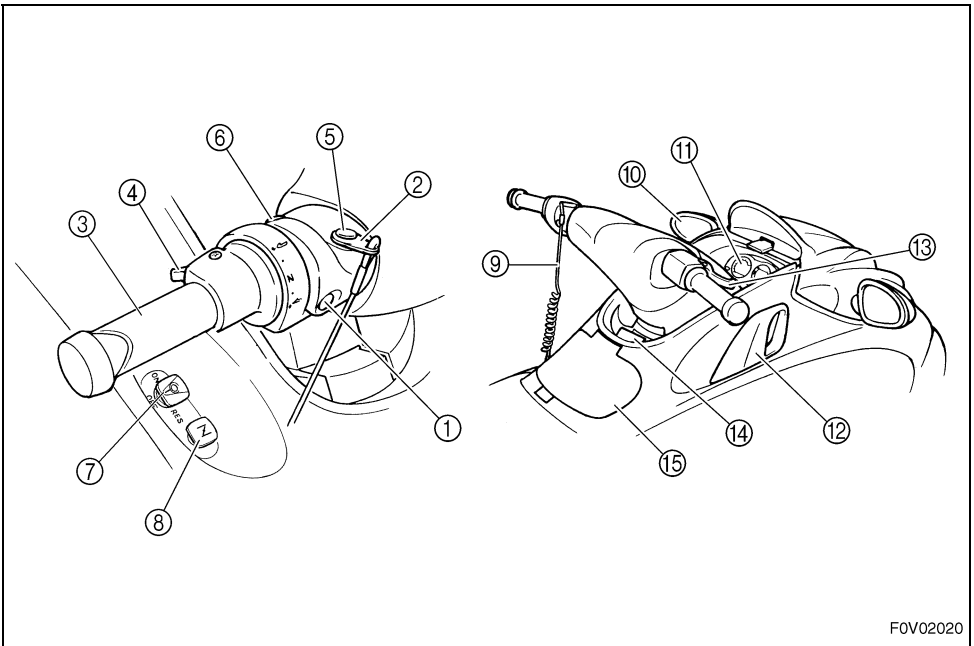

FOV02020

- ① **Engine stop switch**
Push to stop the engine normally.
- ② **Clip**
Insert into the engine shut-off switch to enable starting of the engine.
Remove to stop the engine or prevent accidental starting of the engine or unauthorized use of the watercraft.
- ③ **Quick Shift Trim System (QSTS) selector**
Use to select the trim angle of the watercraft.
- ④ **QSTS shift lock lever**
- ⑤ **Engine shut-off switch**
Remove the clip to stop the engine and disable it from starting.
- ⑥ **Start switch**
Push to start the engine.
- ⑦ **Fuel cock knob**
Use to select either normal or reserve fuel flow from the fuel tank to the carburetors, or to shut off fuel flow.
- ⑧ **Choke knob**
Use to start a cold engine.
- ⑨ **Engine shut-off cord (lanyard)**
Attach to wrist so that the engine stops if the operator falls off the watercraft.
- ⑩ **Adjustable rearview mirrors**
- ⑪ **Multifunction meter**
Use to check watercraft operation.
- ⑫ **Shift lever**
Use to put the watercraft into forward or reverse.
- ⑬ **Throttle lever**
Use to accelerate and decelerate.
- ⑭ **Tilt lever**
Use to adjust the tilt of the handlebars.
- ⑮ **Glove compartment**

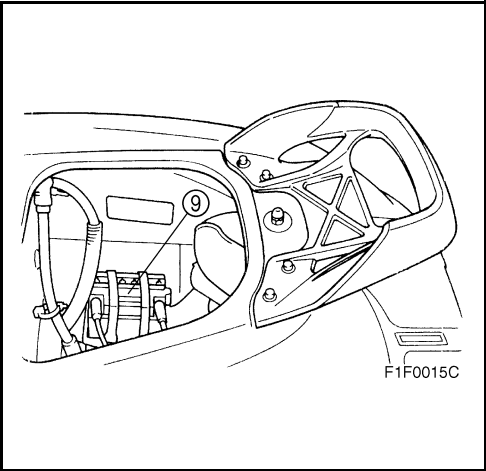
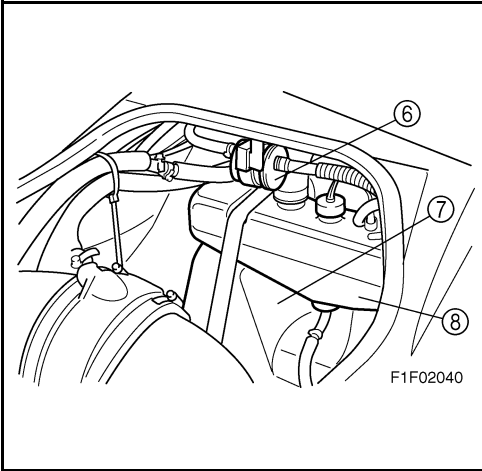
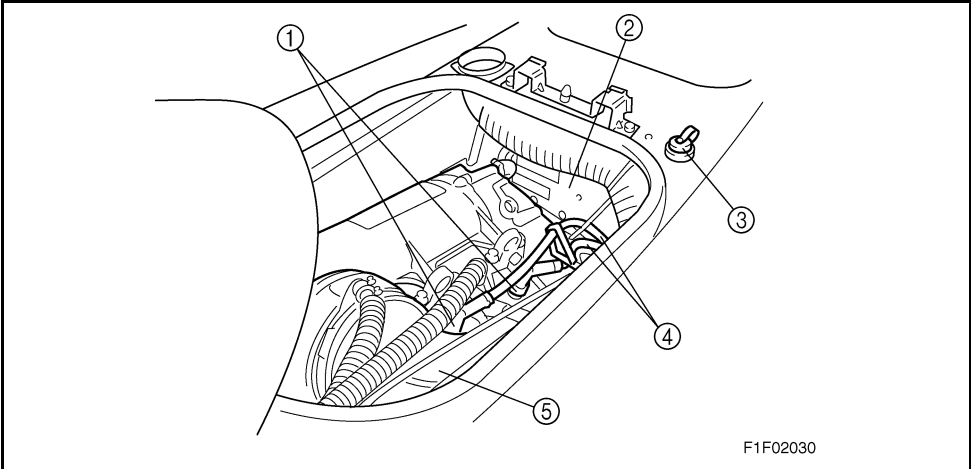

- ① Spark plugs/Spark plug caps
- ② Electrical box
Protects electrical components from water.
- ③ Flush hose connector
Use to flush the engine cooling water passages.
- ④ Spark plug lead
- ⑤ Muffler
- ⑥ Fuel filter
- ⑦ Fuel tank
- ⑧ Oil tank
- ⑨ Battery

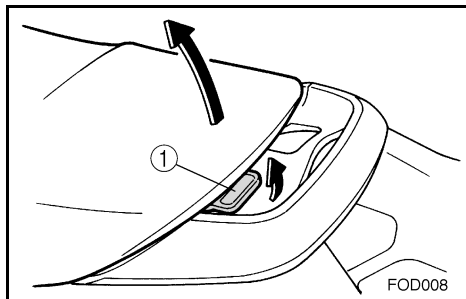

EJU01009

Operation of controls and other functions

EJU01211

Rear seat

To remove the rear seat:

Pull the rear seat latch ① up, and then pull the seat off.

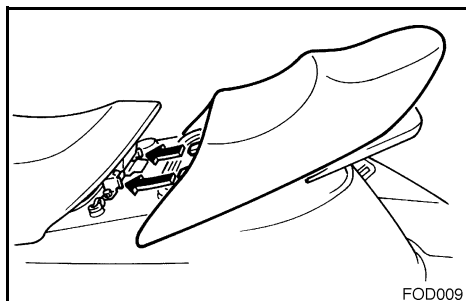

To install the rear seat:

Insert the projections on the front of the seat into the stays on the deck, and then push the rear of the seat down to lock it in place securely.

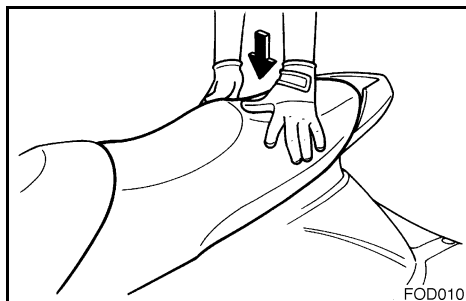



EJU01212

Front seat

To remove the front seat:

1. Remove the rear seat.
2. Pull the front seat latch ② up, and then pull the seat off.

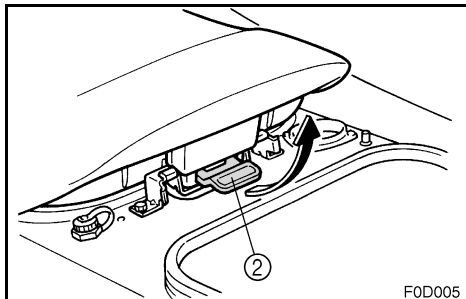

To install the front seat:

1. Insert the projections on the front of the seat into the stays on the deck, and then push the rear of the seat down to lock it in place.
2. Install the rear seat.

NOTE: _____
Make sure that the seats are properly secured before operating the watercraft.

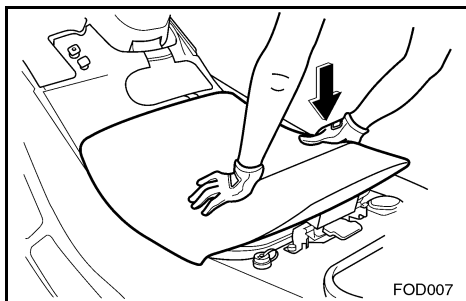
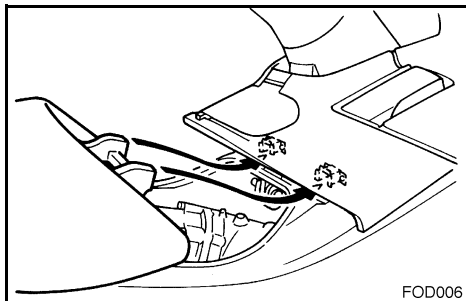



EJU01213

Hood

To open the hood, pull the latch ① up, and then lift the hood up.

To close the hood, push the hood down to lock it in place.

NOTE: _____
Make sure that the hood is properly secured before operating the watercraft.

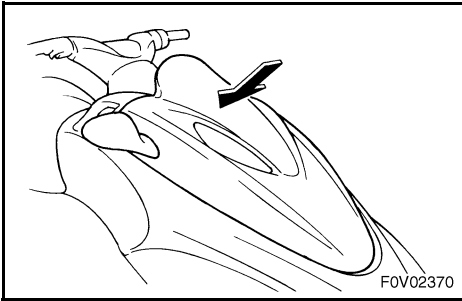
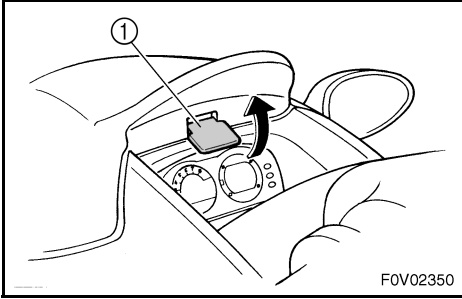

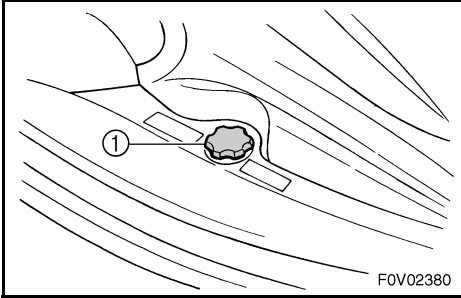

EJU01012

Fuel tank filler cap

To remove the fuel tank filler cap ①, turn it counterclockwise.

NOTE:

Make sure that the fuel tank filler cap is properly secured before operating the watercraft.

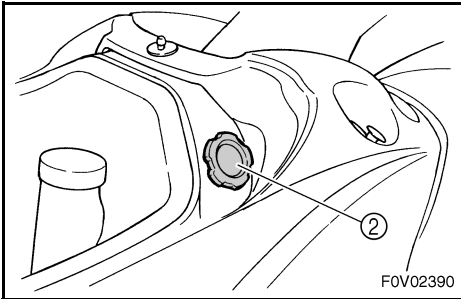

EJU01214

Oil tank filler cap

To remove the oil tank filler cap:

1. Open the hood. (See page 2-7 for hood.)
2. Turn the filler cap ② counterclockwise.

To install the oil tank filler cap:

Install the filler cap, and then close the hood.

NOTE:

Make sure that the oil tank filler cap and hood are properly secured before operating the watercraft.

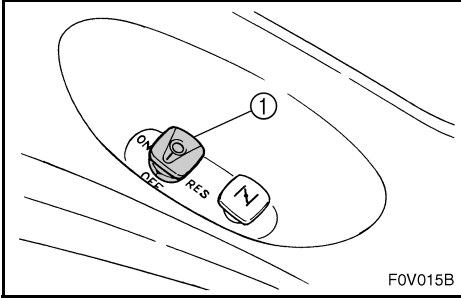

EJU01014

Fuel cock knob

The fuel cock supplies fuel from the fuel tank to the carburetors.

The fuel cock knob ① positions are explained as follows and are shown in the illustration.

OFF:

With the fuel cock knob in this position, fuel does not flow. Always turn the fuel cock knob to this position when the engine is not running.

ON:

With the fuel cock knob in this position, fuel flows to the carburetors. Turn the fuel cock knob to this position when starting the engine and operating the watercraft.

RES:

This indicates reserve. With the fuel cock knob in this position, the fuel reserve is made available. Turn the fuel cock knob to this position if you run out of fuel while operating the watercraft. When this occurs, refuel as soon as possible and be sure to turn the fuel cock knob back to "ON"!

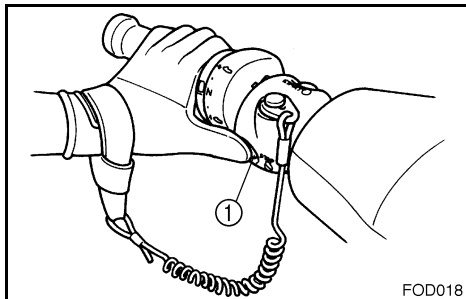

EJU01015

Engine stop switch

Push this switch ① (red button) to stop the engine normally.

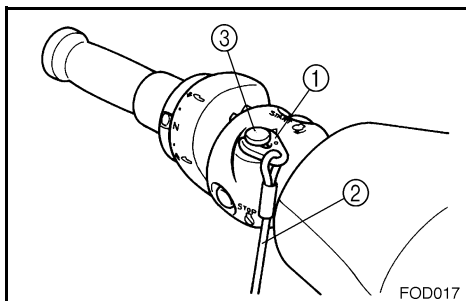

EJU01016

Engine shut-off switch

Insert the clip ①, on the end of the engine shut-off cord ②, under the engine shut-off switch ③ (black button). The engine will stop automatically when the clip is removed from the switch, such as if the operator falls off the watercraft.

⚠WARNING

- Always attach the engine shut-off cord to your wrist and the clip to the engine shut-off switch BEFORE starting the engine.
- To prevent accidental starting of the engine or unauthorized use by children or others, always remove the clip from the shut-off switch when the engine is not running.

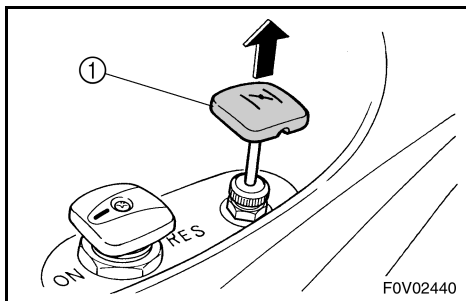
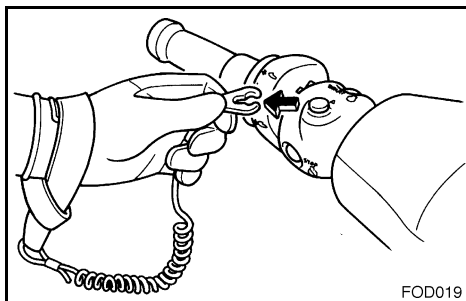

EJU01215

Choke knob

Starting a cold engine requires a richer air-fuel mixture, which is supplied by the choke.

Pull the knob ① out to turn the choke on.
Push the knob in to turn the choke off.

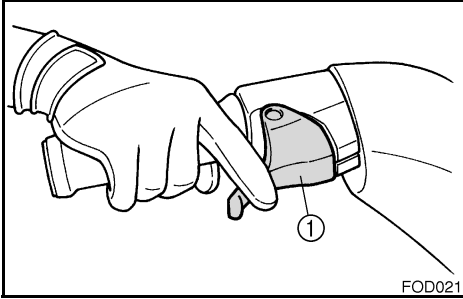

EJU01018

Throttle lever

Squeeze the throttle lever ① to increase engine speed.

Release the throttle lever to decrease engine speed or to return it to the idle position.

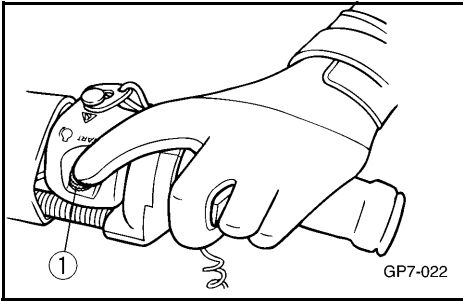

EJU01216

Start switch

Push the start switch ① (green button) to start the engine.

NOTE:

- The engine will not start when the clip is removed from the engine shut-off switch.
- The engine will not start if the “LOCK” mode of the multifunction meter has been selected. (See page 2-20 for “PADLOC” mode selection procedures.)



EJU01020

Cooling water pilot outlet

This watercraft is equipped with a cooling water pilot outlets.

When the engine is running, cooling water is circulated in the engine, and then it is discharged from the pilot outlets.

To check for proper operation of the cooling system, check that water is being discharged from the pilot outlets. If water is not being discharged from the outlets, cooling water may not be circulating in the engine. When this occurs, stop the engine and check for the cause. (See pages 2-17 and 5-4 for further instructions.)

NOTE:

If the cooling water passages are dry, it will take about 20 seconds for the water to reach the outlet after the engine is started.

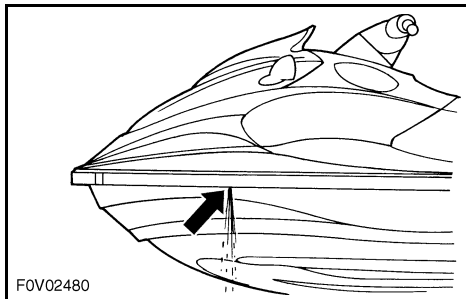

F0V02480

EJU01021

Steering system

Your watercraft can be steered by turning the handlebars ① the same direction you wish to travel.

When the handlebars are turned, the angle of the jet thrust nozzle ② is changed, and the direction of the watercraft is changed accordingly. Since the strength of the jet thrust determines the speed and direction of a turn, the throttle must always be open when attempting a turn, except at trolling speed.

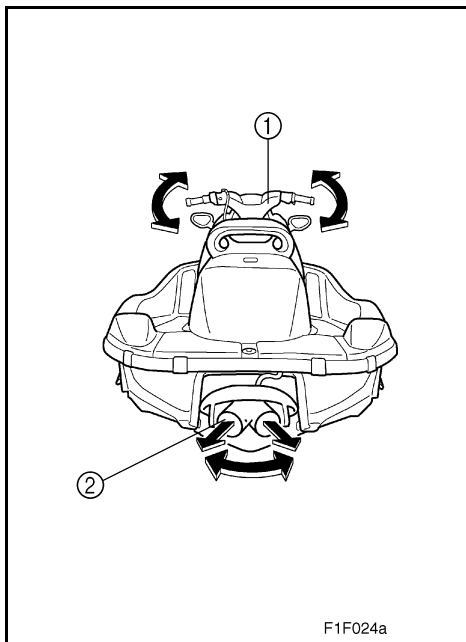

F1F024a



EJU01217

Tilt lever

The tilt lever ① is located in front of the glove compartment and is used to adjust the tilt of the handlebars.

To adjust the tilt, pull the tilt lever up, and then move the handlebars up or down to the desired position.

⚠WARNING

- **Never touch the tilt lever during operation, otherwise the handlebars may suddenly change position, which may lead to an accident.**
- **Be sure to fasten the tilt lever properly after adjusting the handlebar position. If the handlebars are not properly fastened, they may suddenly change position, which may lead to an accident.**

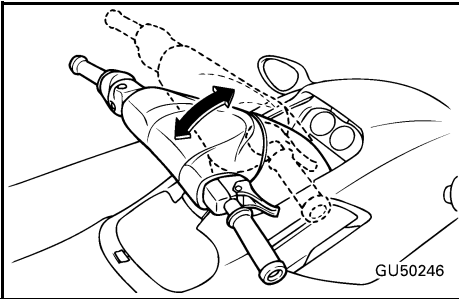
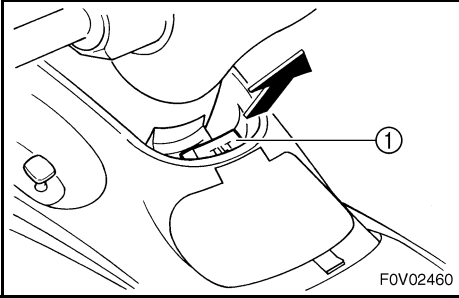



EJU01218

Shift lever

The shift lever is located on the starboard side of the watercraft and is used to control the reverse gate, which allows the watercraft to move into reverse or forward.

When in the reverse position, the watercraft can be launched from a trailer, or backed up out of tight spots where you cannot turn around easily.

To shift into reverse:

1. Release the throttle, and then let the engine speed return to idle.
2. Pull the shift lever toward you.

⚠WARNING

- **Make sure that the throttle is completely released and that the engine is at idle before shifting into reverse.**
- **Do not use the reverse function to slow down or stop the watercraft as it could cause you to lose control, be ejected, or impact the handlebars.**
- **Use reverse for slow-speed maneuvering only.**
- **Make sure that there are no obstacles or people behind you before shifting into reverse.**
- **Do not touch the reverse gate while the shift lever is being operated, otherwise you could be pinched.**

To shift into forward:

1. Release the throttle, and then let the engine speed return to idle.
2. Push the shift lever away from you.

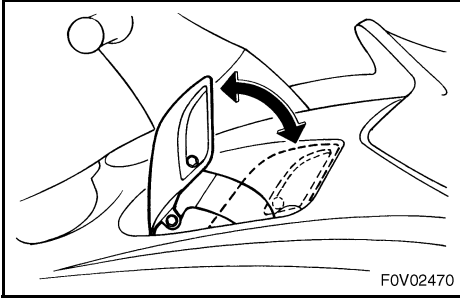



EJU01022

Quick Shift Trim System (QSTS) selector

The QSTS selector ① is located at the left handlebar grip and is used to adjust the trim angle of the watercraft.

Operating the QSTS selector changes the angle of the jet thrust nozzle vertically. This changes the trim angle of the watercraft.

There are 5 positions: 2 bow down positions ① and ②, neutral "N," and 2 bow up positions ③ and ④.

To change the trim angle:

1. Reduce engine speed to 3,400 r/min or less.
2. Squeeze the shift lock lever ②, and then turn the QSTS selector to the desired position.
3. Release the shift lock lever to lock the QSTS selector.

CAUTION:

Do not turn the QSTS selector while operating the watercraft at full throttle, otherwise damage could occur to the QSTS.

The neutral "N" position will provide good performance for most operating conditions.

To enhance particular types of performance, select bow down or bow up.

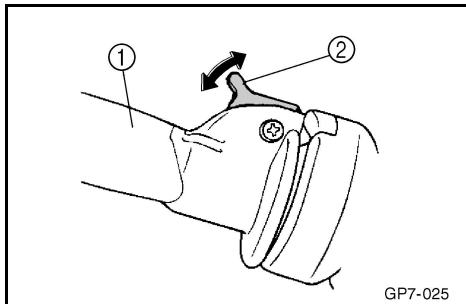

GP7-025

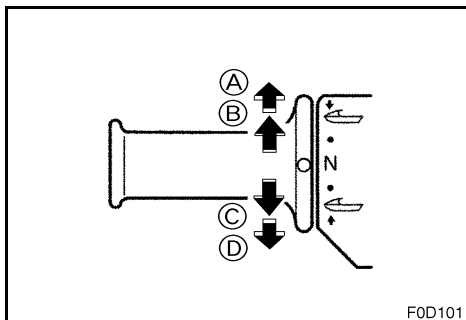
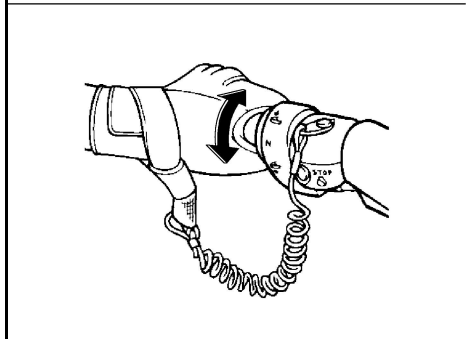

F0D101

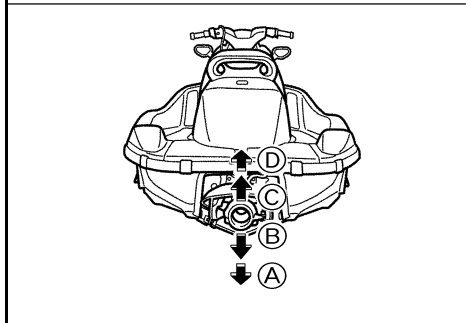



EJU01023

Bow down

Turn the grip to (A) or (B) and the bow will go down while the watercraft is on plane.

Bow down puts more of the bow in the water. This gives the watercraft more “hook,” which enhances turning performance. This position will also help the watercraft get up on plane more quickly.

At higher speeds, however, the watercraft will have greater tendency to “bow steer” and follow waves and wakes in the water. Fuel economy and maximum speed are also reduced.

EJU01024

Bow up

Turn the grip to (C) or (D) and the bow will go up while the watercraft is on plane.

Bow up puts less of the bow in the water. There is less water resistance, so straight-ahead acceleration when on plane and top speed are enhanced.

In some conditions, however, the watercraft may tend to “porpoise” (hop in the water). If the watercraft is porpoising, choose neutral or bow down.

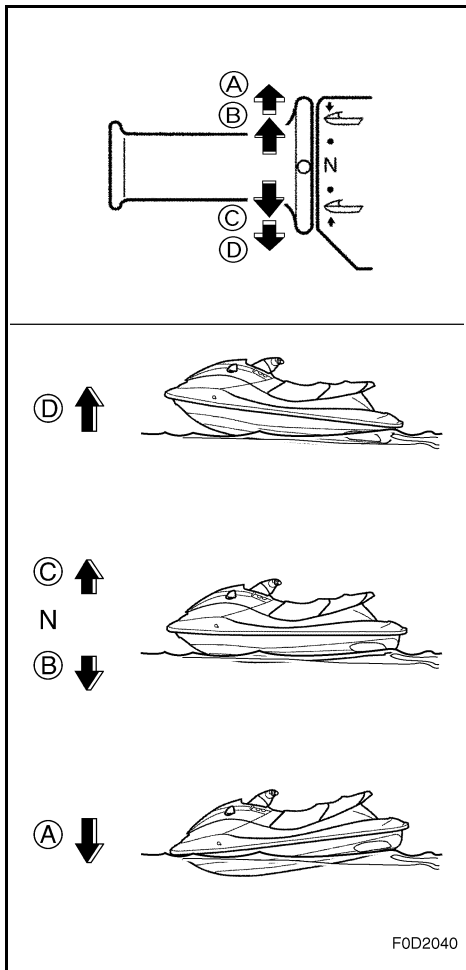

EJU01219

Handgrip

The handgrip ① provides a handhold for boarding the watercraft and for a spotter when facing rearward.

CAUTION: _____

Do not use to tow objects, lift watercraft, or attach tie downs, otherwise damage could occur.

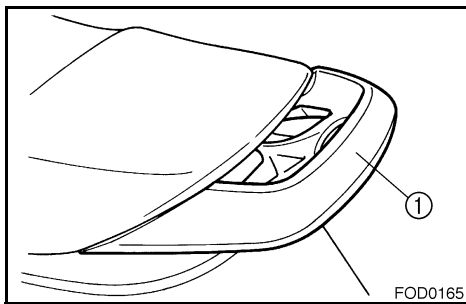



EJU01220

Engine overheat warning system

This model is equipped with an engine overheat warning system.

If the engine starts to overheat, the warning light, the indicator for the water temperature symbol, and "W.TEMP" display begin to blink, the buzzer sounds, and the engine speed will be limited to about 3,400 r/min.

When this occurs, check for water discharge at the cooling water pilot outlet. If there is no discharge of water, reduce the engine speed and beach the watercraft, and then check the intake grate and impeller for clogging.

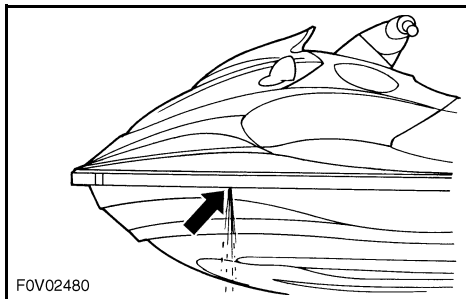
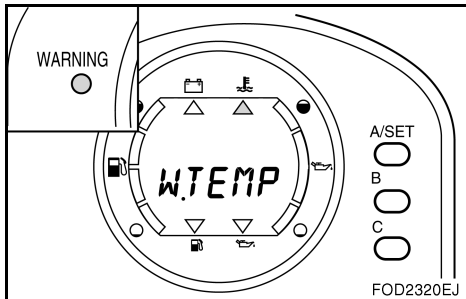

⚠ WARNING

Before attempting to remove weeds or debris from the intake grate or impeller, shut the engine off and remove the clip from the engine shut-off switch. Severe injury or death could result from coming in contact with the rotating parts of the jet pump.

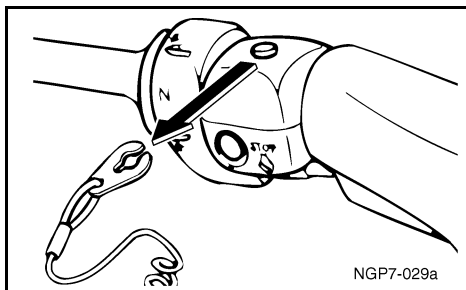

CAUTION:

If you cannot locate and correct the cause of the overheating, consult a Yamaha dealer. Continuing to operate at higher speeds could result in severe engine damage.

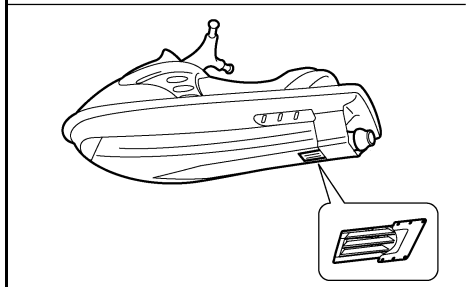

NOTE:

Press any button on the multifunction meter to stop the buzzer.



EJU01221

Multifunction meter

This meter contains following functions for help and convenience in operating the watercraft.

- ① "MODE" button
- ② "SET" button
- ③ "CODE" setting buttons
- ④ Tachometer
- ⑤ Speedometer
- ⑥ Fuel meter
- ⑦ Engine oil meter
- ⑧ Display for Clock, Hour meter, Trip meter and Trip timer
- ⑨ Warning light
- ⑩ Display for PADLOC and direction of warning indicator
- ⑪ Battery warning indicator
- ⑫ Engine overheat warning indicator
- ⑬ Fuel warning indicator
- ⑭ Oil warning indicator

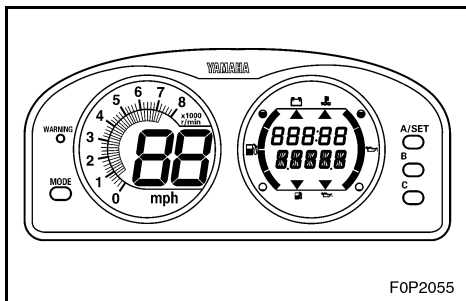
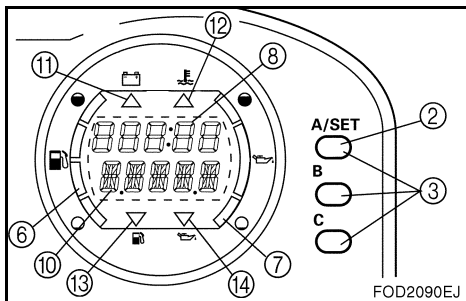
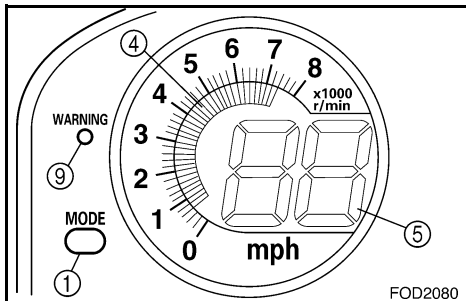
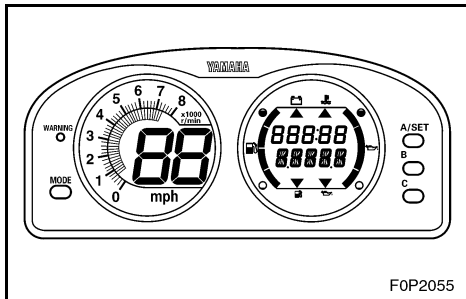

CAUTION:

- Do not run the engine at full throttle or more than 15 seconds to check the meter for operation on land. The engine could overheat.
- Use the specified resistor-type spark plugs and caps, otherwise the meter may function erratically.

NOTE:

The demonstration mode display starts showing after the engine starts. Then all displays light up and the buzzer sounds twice. The meter will operate normally after a few seconds. The current display will continue to operate for 30 seconds after the engine stops.



EJU01222

PADLOC (Programmable digital locking ignition)

This feature is provided to deter unauthorized use.

The function allows you to choose either “START” or “LOCK” mode, as the situation requires, much as you would use an ignition key in a motor vehicle. If you have previously chosen “LOCK” mode, the engine will not start unless the right code is put in to select “START” mode.

NOTE:

If you do not use the PADLOC system, it is unnecessary to perform the initial setting of the PADLOC. In this case, the “START” mode is automatically selected.

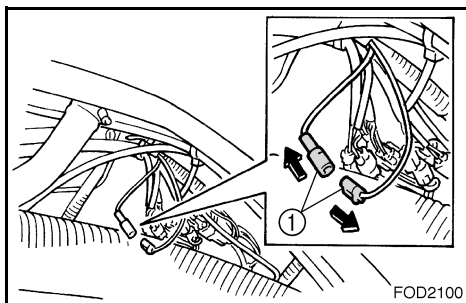

EJU01223

PADLOC initial setting

1. Disconnect the blue connector ① behind the front storage compartment.
2. After the warning light turns on, press the “MODE” button for at least 3 seconds until the display shows “CODe.” You are ready to set your code.

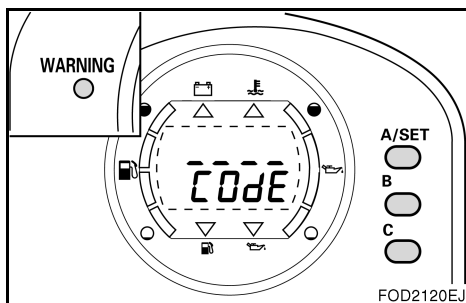
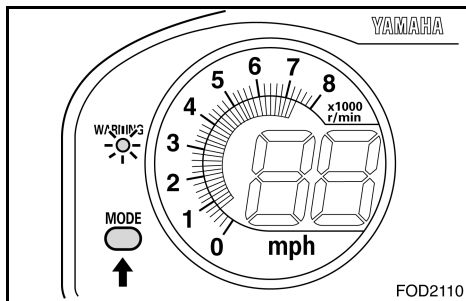

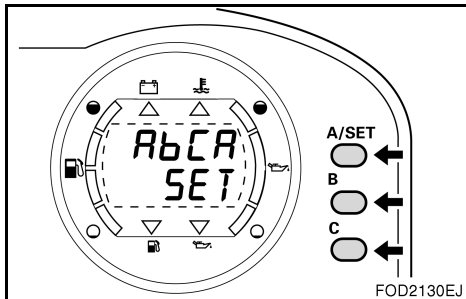

FOD2130EJ

3. Select your four-letter code by pressing the “A/SET,” “B,” or “C” buttons in a desired sequence.

NOTE: _____
If you do not press a button for more than 10 seconds, the display automatically turns off. This cancels the process of setting a code.

4. After code setting is complete, the buzzer will sound 3 times and the display will show “SET.” Lastly, the display turns off and the warning light turns on again. After the meter has displayed this sequence, connect the blue connector again.

NOTE: _____
● Your own code is kept even if the battery terminal is disconnected.
● If you forget your own code, or if you want to change the code, do this initial setting procedure again from the beginning.

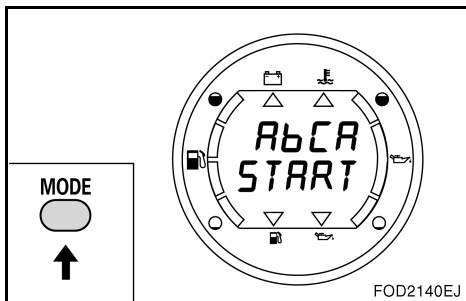

FOD2140EJ

EJU01224

Selecting “PADLOC” mode

Selecting the desired mode can only be done after the initial setting has been done and while the display is not lit.

1. Press the “MODE” button until the meter displays the current mode, “START” or “LOCK.”

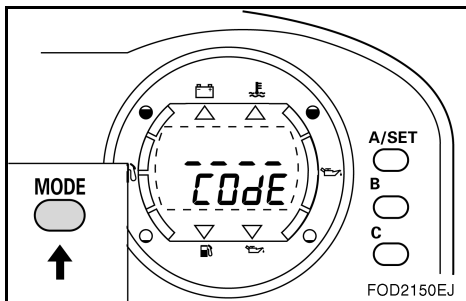

FOD2150EJ

2. With “START” or “LOCK” displayed, press the “MODE” button continuously for about 3 seconds until the display changes to “COdE.”

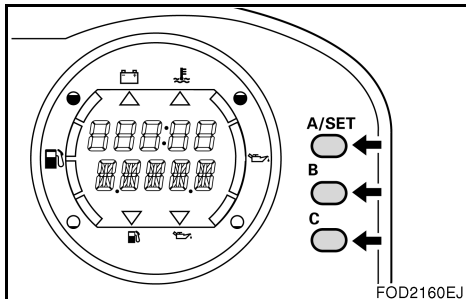

3. Enter your four-letter code by pressing the “A/SET,” “B,” or “C” buttons in the right sequence.

NOTE: _____
 If you do not press a button for more than 10 seconds, the display automatically turns off. This cancels the process of selecting the mode.

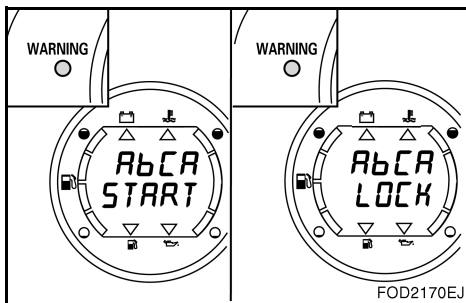

4. If the code entered is correct, the mode will change from the previous mode to either “START” or “LOCK.” Then the mode display and buzzer will operate for 2 seconds.

NOTE: _____
 ● Once you select a mode, the mode will not change unless you perform this mode selection sequence again.
 ● If the wrong code is entered, the mode display shows “ERROR” for 2 seconds and the buzzer will sound 5 times. Then the display returns to “CoDE.”

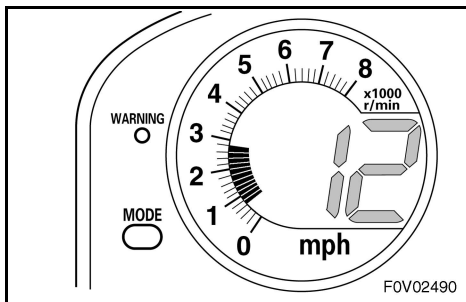
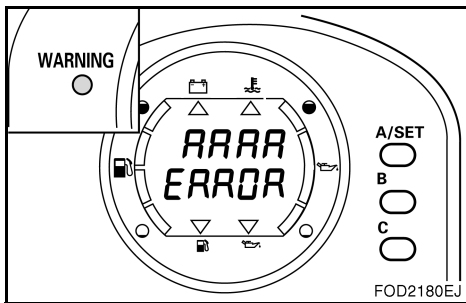

EJU01225

Tachometer

The engine speed (r/min) is displayed by segments. Each segment indicates a 200 r/min increment.

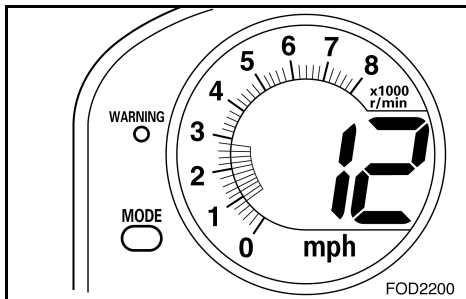

EJU01226

Speedometer

The meter shows the watercraft speed against water.

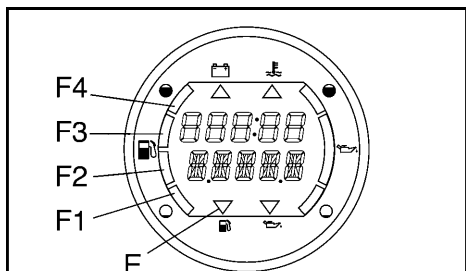

EJU01227

Fuel meter

The fuel meter is provided for convenient fuel level checking while operating the watercraft.

The fuel meter has 4 segments which show the amount of fuel remaining in the fuel tank.

NOTE: _____
 The indication of the segments differs depending on your operating condition. Use the meter as a reference.

Display		Capacity:L(US gal, Imp gal)	
F4 F3 F2 F1		ON	more than 54 (14.3, 11.9)
F3 F2 F1		ON	45~54 (11.9, 9.9)~(14.3, 11.9)
F2 F1		ON	28~45 (7.4, 6.2)~(11.9, 9.9)
F1		ON	17~28 (4.5, 3.7)~(7.4, 6.2)
E		Blinking	0~17 (4.5, 3.7)



EJU01228

Engine oil meter

The engine oil meter is provided for convenient oil level checking while operating the watercraft.

The engine oil meter has 3 segments which show the amount of oil remaining in the oil tank.

NOTE:

The indication of the segments differs depending on your operating condition. Use the meter as a reference.

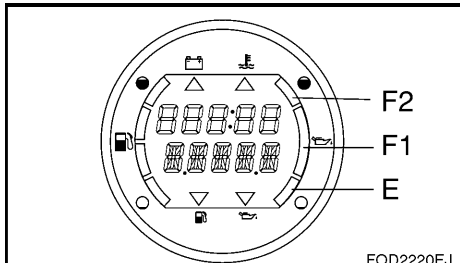

FOD2220EJ

Display			Capacity:L(US gal, Imp gal)
F2 F1		ON	more than 3.7 (0.97,0.81)
F1		ON	1.4~3.7 (0.37,0.31)~(0.97,0.81)
E		Blinking	0~1.4 (0.37,0.31)

EJU01229

Clock

A 12-hour clock is provided in this meter.

To show the clock, press the "MODE" button until the display shows "CLOCK" while the engine is running.

1. When the display shows "CLOCK," press the mode button for at least 3 seconds.
2. The buzzer will sound once. The hour display and "SET" start blinking. Then press the "A/SET" button until the desired hour is displayed.
3. Press the "MODE" button again.
4. The buzzer will sound once. The minute display and "SET" start blinking. Then press the "A/SET" button until the desired minute is displayed.
5. Press the "MODE" button again.

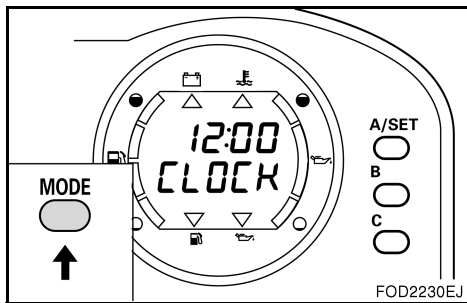

FOD2230EJ

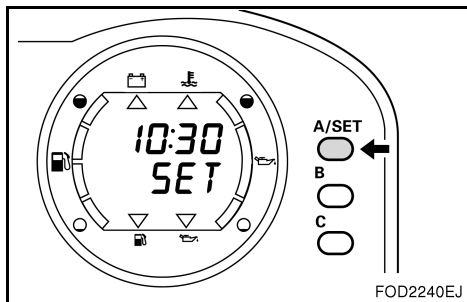

FOD2240EJ



- The buzzer will sound twice. The warning light and “SET” blink for 2 seconds. Then the display turns to “CLOCK” and shows the time.

NOTE:

If the battery terminal is disconnected, the clock will be reset to 12:00.

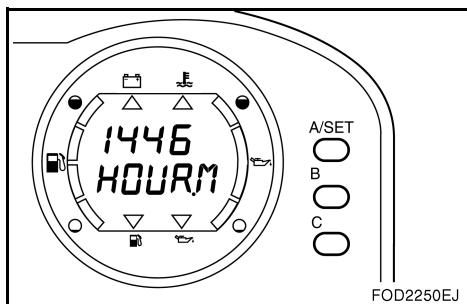

EJU01230

Hour meter

The hour meter is provided to make it easy to follow the maintenance schedule.

The meter shows how many hours of engine operation have elapsed since the watercraft was new.

To show the hour meter, press the “MODE” button until the display shows “HOUR.M” while the engine is running.

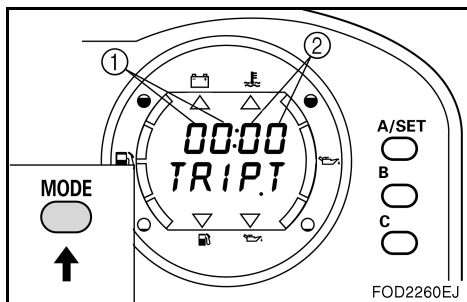

EJU01231

Trip timer

The trip timer is provided for counting the time traveled on a given trip.

To show the trip timer, press the “MODE” button until the display shows “TRIP.T” while the engine is running.

- Minutes
- Seconds

- When the display shows “TRIP.T,” press the “A/SET” button to start counting. The buzzer will sound once.
- Press the “A/SET” button again to stop counting. The buzzer will sound once.
- Press “MODE” button for at least 2 seconds to set the time back to 00:00. The buzzer will sound twice. The time display and “TRIP.T” blink for 2 seconds. Now it is ready to start counting.

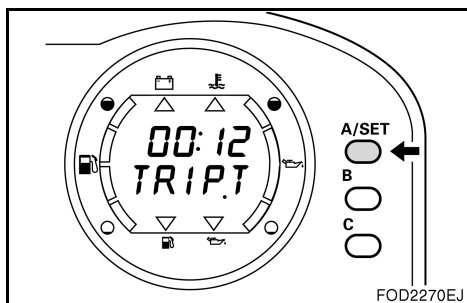



EJU01163

Tripmeter

A tripmeter is provided for measuring the approximate distance traveled.

To show the tripmeter, press the "MODE" button until the display shows "TRIP" while the engine is running. After showing "TRIP," the display turns to ".MILE."

1. When the display shows ".MILE," press the "MODE" button for at least 2 seconds.
2. The buzzer will sound twice. The warning light and ".MILE" blink for 2 seconds, and "000" is displayed. Now the meter will start to measure the distance you travel.
3. When the tripmeter begins measuring the distance traveled, the "." to the left of "MILE" on the display will blink.

NOTE:

Measured distance may vary depending on the water surface conditions, and wind direction. The measured distance should be used for a reference.

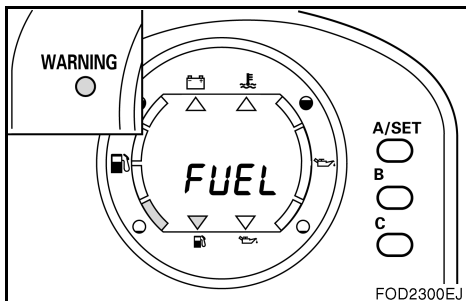
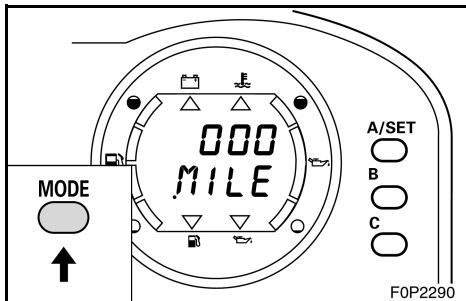
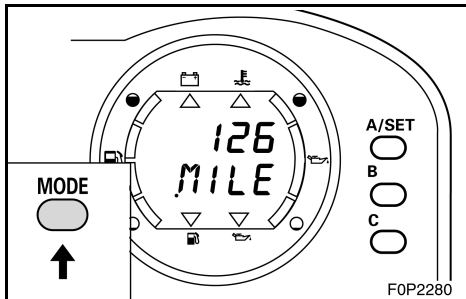

EJU01232

Fuel warning indicator

If the fuel remaining in the tank drops to about 17 L (4.5 US gal, 3.7 Imp gal), the lowest fuel level segment, the fuel warning indicator, "FUEL" and the warning light begin to blink. The buzzer also starts sounding intermittently.

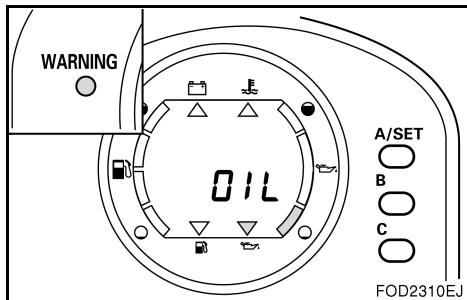

EJU01233

Oil warning indicator

If the oil remaining in the tank drops to about 1.4 L (0.37 US gal, 0.31 Imp gal) or the oil filter is clogged, the lowest oil level segment, the oil warning indicator, “OIL” and the warning light begin to blink. The buzzer also starts sounding intermittently.

If the oil warning indicator begins to blink, refill with engine oil as soon as possible.

NOTE: If the warning indicator blinks with adequate oil in the tank, check the oil filter for clogging.

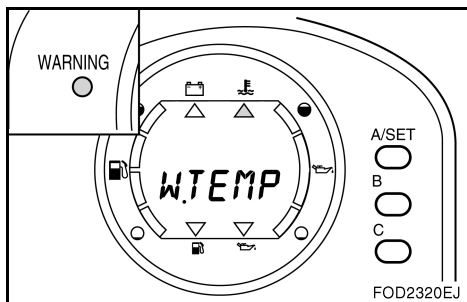

EJU01234

Engine overheat warning indicator

If the engine starts to overheat, the overheat warning indicator, “W.TEMP” and the warning light begin to blink. The buzzer also starts sounding intermittently.

Refer to “Engine overheat warning system” on page 2-17.

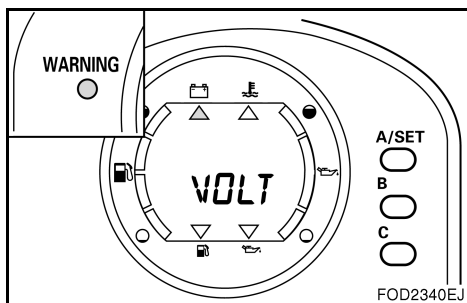

EJU01235

Battery warning indicator

If the battery voltage becomes less than 11.5 volts, the battery warning indicator, “VOLT” and the warning light begin to blink. The buzzer also starts sounding.

If this happens during operation, beach the watercraft. Then recharge the battery and have the charging system inspected by a Yamaha dealer.

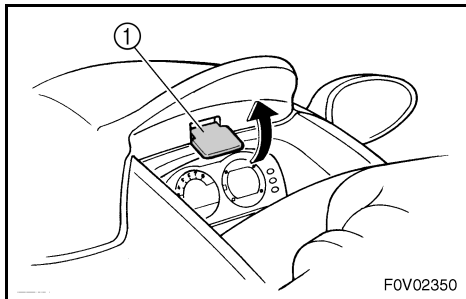

EJU01236

Storage compartments

A front storage compartment, a glove compartment, and seat storage compartments are provided.

NOTE: _____

- Make sure that the storage compartments are properly secured before operating the watercraft.
- The storage compartments are not designed to be waterproof. If you carry objects that must be kept dry, such as the manuals, put them in a waterproof bag.

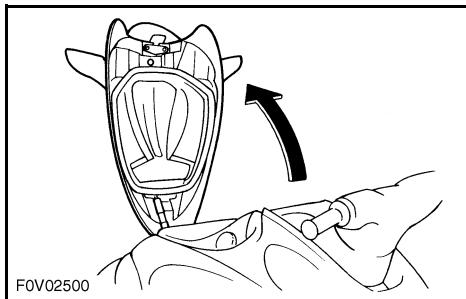

EJU01237

Front storage compartment

The front storage compartment ② is located at the bow.

To open the front storage compartment, pull the hood latch ① up, and then open the hood.

To close the front storage compartment, push down on the rear of the hood until it latches securely.

NOTE: _____

The front storage compartment can be removed to access the engine compartment.

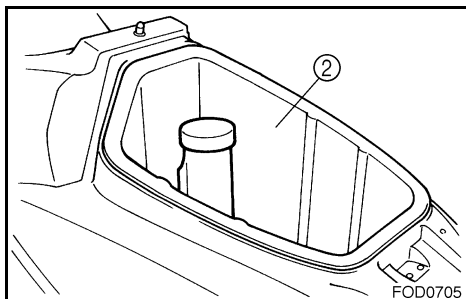

Front storage compartment: Capacity: 56 L (15 US gal, 12 Imp gal) Load limit: 5 kg (11 lb)
--

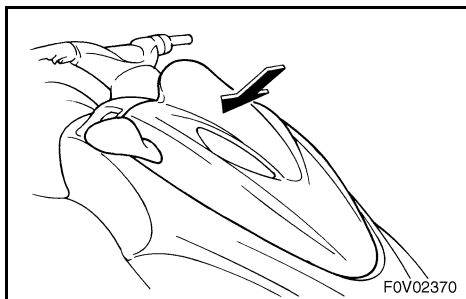



EJU01038

Glove compartment

A glove compartment ④ is located in front of the seat.

To open the glove compartment, slide the latch ③ toward you, and then lift up the lid.

To close the glove compartment, push the lid down until it locks securely.

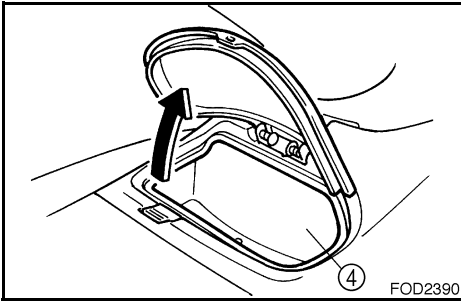
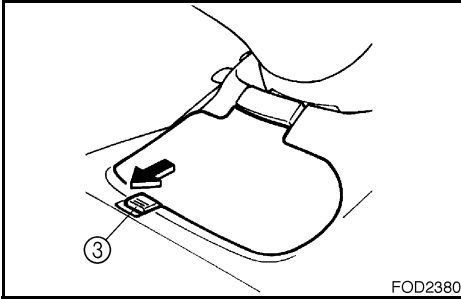

Glove compartment:
Capacity: 1.7 L (0.45 US gal, 0.37 Imp gal)
Load limit: 1 kg (2.2 lb)

EJU01239

Seat storage compartment

The seat storage compartment ⑤ is located under the rear seat.

To open the seat storage compartment, remove the rear seat. (See page 2-5 for rear seat.)

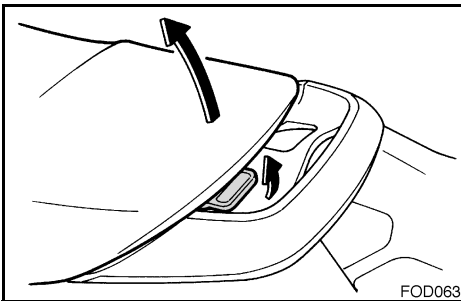

Seat storage compartment:
Capacity: 30 L (8 US gal, 6.6 Imp gal)
Load limit: 9 kg (19.8 lb)

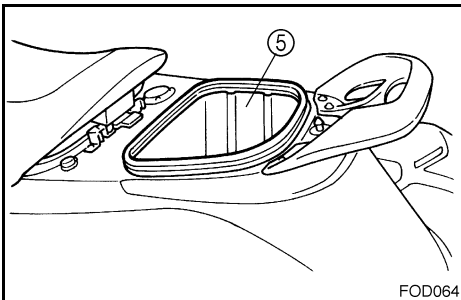



-MEMO-

OPERATION

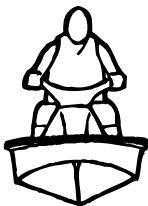

Fuel and oil	3-1
Gasoline	3-1
2-stroke engine oil	3-2
Filling the fuel tank	3-3
Filling the oil tank	3-4
Pre-operation checks	3-5
Pre-operation check list	3-5
Pre-operation check points	3-6
Operation	3-14
Engine break-in	3-14
Launching the watercraft	3-16
Starting the engine	3-16
Stopping the engine	3-19
Leaving the watercraft	3-19
Operating your watercraft	3-20
Getting to know your watercraft	3-20
Learning to operate your watercraft	3-20
Riding watercraft with passengers	3-21
Starting the watercraft	3-22
Boarding and starting in deep water	3-24
Capsized watercraft	3-26
Turning the watercraft	3-28
Stopping the watercraft	3-30
Beaching the watercraft	3-31
Docking the watercraft	3-31
Reverse on waterways	3-32
Rough water operation	3-32
Post-operation checks	3-33
Transporting	3-35



EJU01041

Fuel and oil

This engine uses Yamaha's oil injection system, which provides superior lubrication by ensuring the proper oil ratio for all operating conditions. No fuel premixing is necessary except during the engine break-in period. Simply pour gasoline into the fuel tank and oil into the oil tank.

EJU01042

Gasoline

⚠WARNING

GASOLINE AND ITS VAPORS ARE HIGHLY FLAMMABLE AND EXPLOSIVE!

- Do not smoke when refueling, and keep away from sparks, flames, or other sources of ignition.
- Stop engine before refueling.
- Refuel in a well-ventilated area. Do not stand or sit on the watercraft while refueling in case of fire.
- Take care not to spill gasoline. If gasoline spills, wipe it up immediately with dry rags. Always properly dispose of gasoline-soaked rags.
- Avoid overfilling the fuel tank. Stop filling when the fuel level just reaches the bottom of the filler tube. Do not fill up the filler tube because fuel expands as it warms up and could overflow.
- Tighten the filler cap securely after refueling.
- If you should swallow some gasoline, inhale a lot of gasoline vapor, or get gasoline in your eyes, get immediate medical attention.
- If any gasoline spills onto your skin, immediately wash with soap and water. Change clothing if gasoline spills on it.

**CAUTION:**

Use only fresh gasoline that has been stored in clean containers.

Recommended gasoline:

Regular unleaded gasoline with a minimum octane rating of

86 (Pump octane number) = $(R+M)/2$

90 (Research octane number)

EJU01043

Gasohol

There are two types of gasohol: gasohol containing ethanol and that containing methanol.

Gasohol containing ethanol can be used if ethanol content does not exceed 10 % and the fuel meets minimum octane ratings.

Gasohol containing methanol is not recommended by Yamaha because it can cause fuel system damage or engine performance problems.

EJU01044

2-stroke engine oil

Recommended engine oil:

YAMALUBE 2-W

If YAMALUBE 2-W is not available, another 2-stroke engine oil with an NMMA-certified TC-W3 rating may be used.

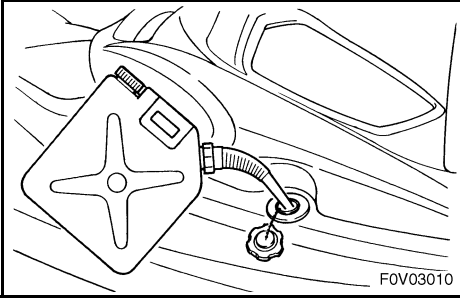

EJU01045

Filling the fuel tank

CAUTION:

Be careful when refueling. Avoid getting water or other contaminants in the fuel tank. Contaminated fuel can cause poor running or engine damage.

1. Open the hood and remove the front storage compartment, to check the fuel level. (See page 2-27 for front storage compartment.)
2. Open the fuel tank filler cap, and slowly add fuel to the fuel tank.
3. Stop filling when the fuel just reaches the bottom of the filler tube on the fuel tank. Do not fill into the filler tube, because fuel could spill out.

Fuel tank capacity:

Total: 70 L (18.5 US gal, 15.5 Imp gal)

Reserve: 12 L (3.2 US gal, 2.7 Imp gal)



EJU01240

Filling the oil tank

⚠ WARNING

- Do not add gasoline to the oil tank. Fire or explosion could result.
- Oil in the bilge is a serious fire hazard. Wipe up any spilled oil immediately.

CAUTION:

Do not allow the oil tank to become completely empty. If the oil tank becomes empty the oil injection pump must be bled to ensure proper oil flow, otherwise engine damage may occur. If bleeding of the oil pump is necessary, have a Yamaha dealer bleed it.

1. Open the hood to access the oil tank filler cap. Also, remove all seats to watch the oil level. (See page 2-7 for hood, and 2-5 and 2-6 for rear and front seat.)
2. Open the oil tank filler cap, and very slowly add engine oil to the oil tank.
3. Stop pouring when the oil just reaches the bottom of the filler tube.

Oil tank capacity:
5.5 L (1.5 US gal, 1.3 Imp gal)

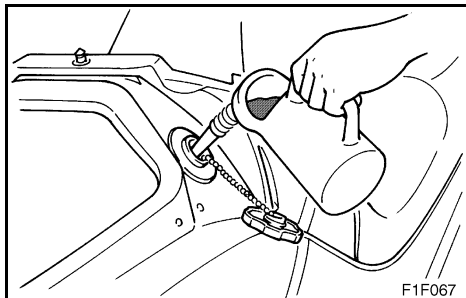



EJU01346

Pre-operation checks

EJU01349

Pre-operation check list

Before operating this watercraft, perform the checks in the following check list. See the accompanying text in this chapter for details on how to perform the checks.

⚠ WARNING

If any item in the pre-operation check list is not working properly, have it inspected and repaired before operating the watercraft, otherwise an accident could occur.

ITEM	ROUTINE	PAGE
Engine compartment	Remove all seats and front storage compartment to ventilate engine compartment. Check for fuel vapors or loose electrical connections	3-6
Bilge	Check for water and fuel residue and remove if necessary	3-7
Throttle	Check that the throttle lever springs back	3-10
Steering system	Check for proper steering system operation	3-10
Shift lever and reverse gate	Check for proper operation	3-11
Fuel and oil	Check fuel and oil level and add if necessary Check hoses and tanks for leakage	3-6
Water separator	Check for water and drain if necessary	3-7
Battery	Check electrolyte level and battery condition	3-8
Front and rear seats	Check that the seats are properly secured	2-5, 2-6
Hull/Deck	Check the hull and deck for cracks or other damage	—
Jet unit	Check for debris and remove if necessary	3-12
Fire extinguisher	Check the condition and replace if necessary	3-9
Engine shut-off cord	Check condition and replace if frayed or broken	3-12
Switches	Check the start switch, engine stop switch and engine shut-off switch for proper operation when the watercraft is in the water	3-13
Cooling water pilot outlet	Check that water is discharged while the engine is running and the watercraft is in the water	3-13
Multifunction meter	Check for warning indications and proper operation	3-13

NOTE:

Pre-operation checks should be made thoroughly each time the watercraft is used. This procedure can be completed in a short time. It is worth the time spent to assure safety and reliability.

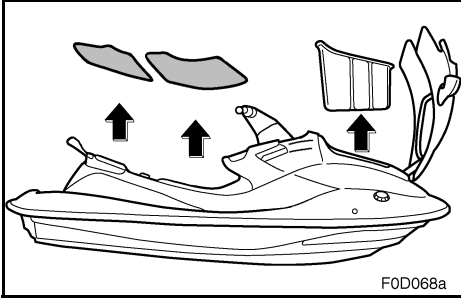

EJU01048

Pre-operation check points

EJU01241

Engine compartment

Ventilate the engine compartment before each use.

To ventilate the engine compartment, remove all seats and front storage compartment. (See pages 2-5 and 2-6 for front and rear seat, and 2-27 for front storage compartment.) Allow the engine compartment to remain open for a few minutes to allow any fuel vapors to escape. Also, check for loose electrical connections.

⚠WARNING

Failure to ventilate the engine compartment could result in fire or explosion. Do not start the engine if there is a fuel leak or a loose electrical connection.

EJU01242

Fuel and oil systems

Check the fuel system for leakage, cracks or malfunctions before each use. (See page 4-9 for check points and correct procedures.)

1. Remove the fuel tank filler cap to release any pressure that might have built up in the fuel tank.
2. Remove all seats and front storage compartment. (See pages 2-5 and 2-6 for front and rear seat, and 2-27 for front storage compartment.)
3. Check the fuel and oil levels in the tanks and replenish if necessary. (See pages 3-3 and 3-4 for filling instructions.)

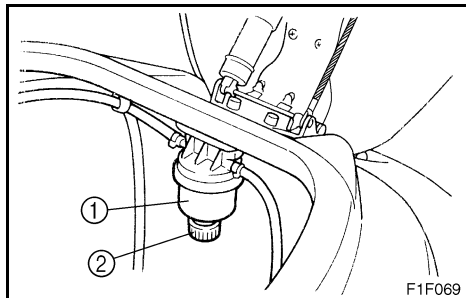

EJU01052

Water separator

Check the water separator ① for water. Normally the water separator is empty. The water separator retains any water entering through the fuel tank breather hose if the watercraft is capsized.

If water remains in the water separator, drain it by removing the drain screw ②. Install the drain screw again after draining the water separator.

EJU01053

Bilge

Check for moisture and fuel residue in the bilge.

Excessive water in the bilge can splash into the carburetor and engine which could cause engine damage.

To remove water from the bilge:

1. Remove the stern drain plugs.
2. Raise the bow of the watercraft until the water drains.
3. After the water has drained, wipe the bilge with dry rags to make sure that the bilge is thoroughly dry.
4. Install the drain plugs.

CAUTION:

- Make sure that the stern drain plugs are tightened securely before launching the watercraft.
- Clean any foreign materials, such as dirt or sand, from the drain plug threads before installing the drain plugs.

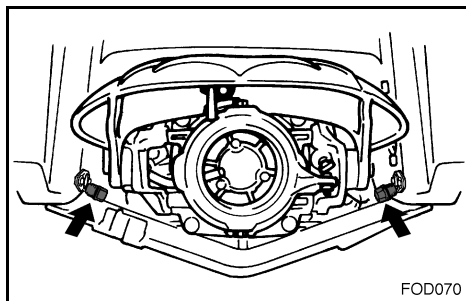



EJU01054

Battery

Check the battery condition and the electrolyte level.

Check that the battery leads are tightened securely and there is no corrosion on the battery terminals.

⚠WARNING

The battery must always be fully charged and in good condition. Loss of battery power may leave you stranded. Never operate the watercraft if the battery does not have sufficient power to start the engine or if it shows any other signs of decreased power.

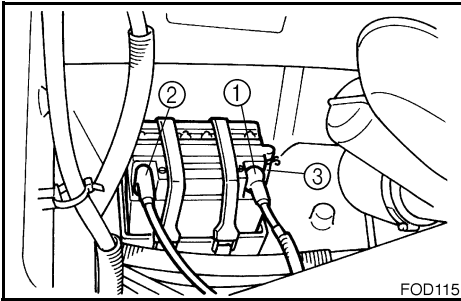

Make sure that the breather hose is properly connected and that it is not damaged or obstructed.

Make sure that the battery is securely held in place.

- ① Positive (+): Red lead
- ② Negative (-): Black lead
- ③ Breather hose



EJU01164

Fire extinguisher

Check that there is a full fire extinguisher on board. The fire extinguisher container ① is located in the front storage compartment.

To open the fire extinguisher container cap ② turn it counterclockwise.

After inserting the fire extinguisher make sure that the container cap is tightened securely.

NOTE:

- See the instructions supplied by the fire extinguisher manufacturer for checking the fire extinguisher. Always keep the extinguisher in the fire extinguisher container.
- Always carry a fire extinguisher on board. A fire extinguisher is not standard equipment with this watercraft. If you do not have one, contact a Yamaha dealer or a fire extinguisher dealer to obtain one meeting the proper specifications.

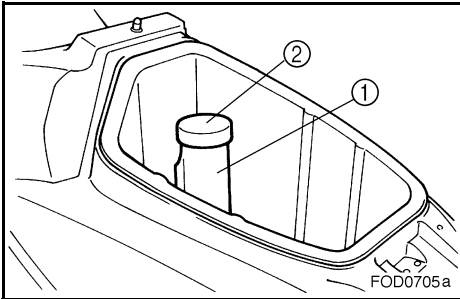
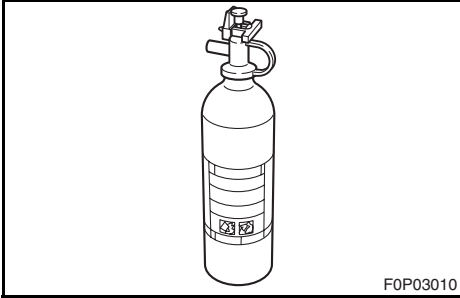

Fire extinguisher:

Classification: B-1

Capacity: 2 lb or more

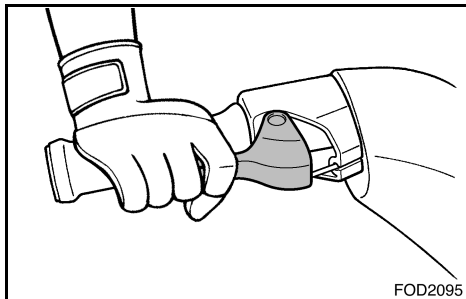

EJU01056

Throttle

Squeeze and release the throttle lever several times to make sure that there is no hesitation in its travel. It should be smooth over the complete range, and spring back to the idle position when released.

⚠WARNING

Before starting the engine, always check the operation of the throttle lever. It should move smoothly through its full range of operation, and should spring back to the idle position when released.

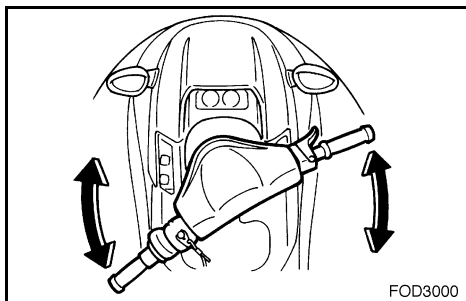

EJU01244

Steering system

Check for looseness in the handlebars.

Turn them as far as possible to the right and left to make sure that operation is smooth and unrestricted throughout the whole range. Make sure that the jet thrust nozzle also changes directions as the handlebars are turned, and that there is no free play between the handlebars and the jet thrust nozzle.

Check that the tilt adjustment is locked in position. (See Tilt lever on page 2-13.)

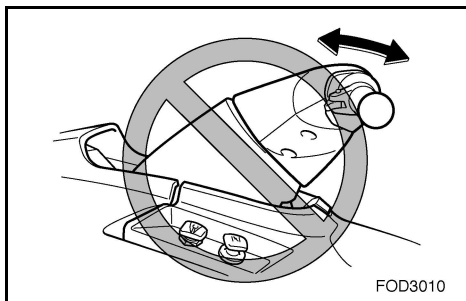

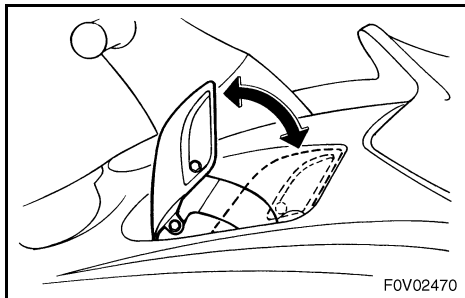

EJU01245

Shift lever and reverse gate

Check for proper operation of the shift lever and reverse gate.

Make sure that the reverse gate goes down to its stopper position when the shift lever is pulled up.

Also, make sure that the reverse gate goes up to its stopper position when the shift lever is pushed down.

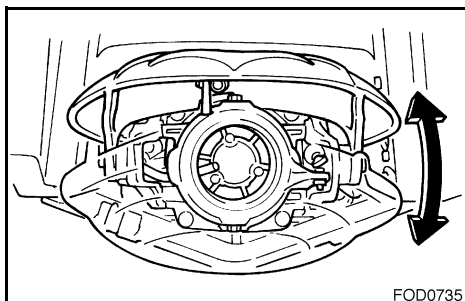

⚠WARNING

- Make sure that the throttle is completely released and that the engine is at idle before shifting into reverse.
- Do not use the reverse function to slow down or stop the watercraft as it could cause you to lose control, be ejected, or impact the handlebars.
- Use reverse for slow-speed maneuvering only.
- Make sure that there are no obstacles or people behind you before shifting into reverse.
- Do not touch the reverse gate while the shift lever is being operated, otherwise you could be pinched.

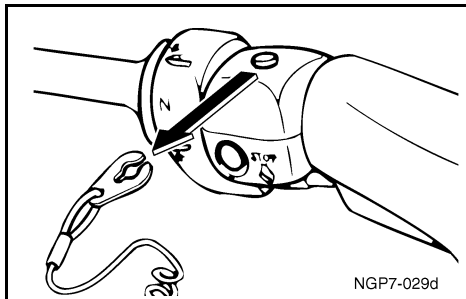

EJU01058

Jet unit

Carefully check the jet intake for weeds, debris, or anything else that might restrict the intake of water. If the intake is clogged, cavitation could occur, reducing jet thrust, and possibly damaging the jet pump.

In some cases, the engine may overheat because of lack of cooling water, and damage to the engine could result. Engine cooling water is fed to the engine by the jet pump. (See page 5-4 for jet intake cleaning procedures.)

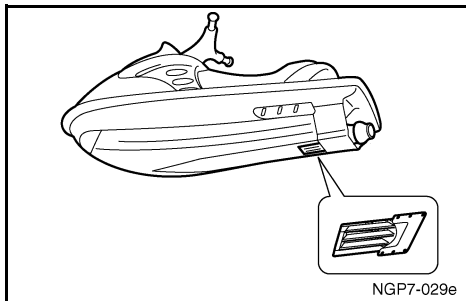

⚠ WARNING

- Keep away from intake grate while engine is on. Items such as long hair, loose clothing, or PFD straps can become entangled in moving parts resulting in severe injury or drowning.
- Stop the engine and remove the clip from the engine shut-off switch before removing any debris or weeds, which may have collected around the jet intake.

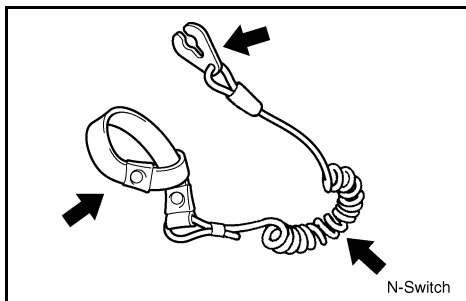

EJU01059

Engine shut-off cord (lanyard)

Check that the engine shut-off cord is not frayed or broken. If the cord is damaged, replace it; never try to repair it or tie it together.

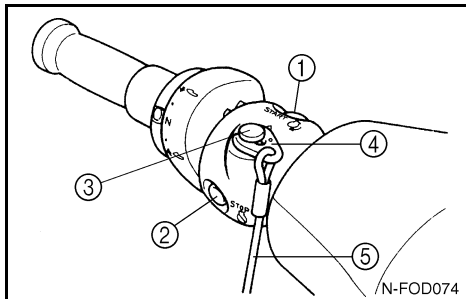

EJU01060

Switches

Check the start switch ①, the engine stop switch ②, and the engine shut-off switch ③ for proper operation.

To check these switches place the watercraft in the water to provide adequate cooling. Start the engine, and then pull the engine shut-off cord ⑤ to remove the clip ④ from the engine shut-off switch. Verify that the engine stops immediately. (See pages 3-16 to 3-19 for information on proper operation of the start switch, the engine stop switch and the engine shut-off switch.)

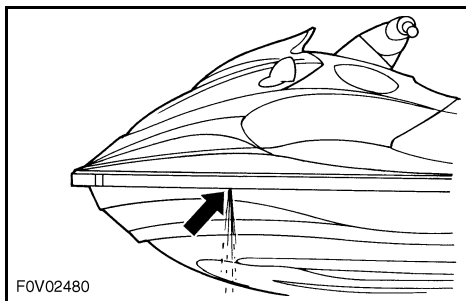

EJU01061

Cooling water pilot outlet

Check that water comes out from the outlets while the engine is running and the watercraft is in the water.

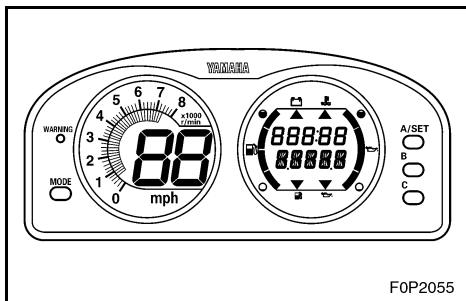

EJU01246

Multifunction meter

Check the operation of the multifunction meter. (See pages 2-18 to 2-26 for operation of the meter.)



EJU01063

Operation

⚠ WARNING

Before operating your watercraft, become familiar with all controls. Consult your Yamaha dealer about any control or function you do not fully understand. Failure to understand how controls work could cause an accident or prevent you from avoiding an accident.

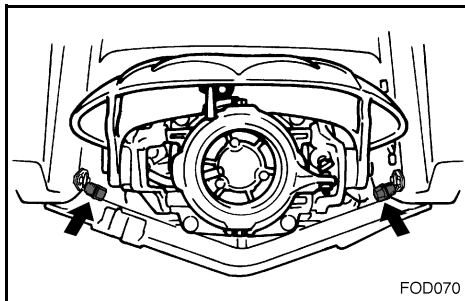

CAUTION:

Make sure that stern drain plugs are securely tightened before launching the watercraft.

EJU01064

Engine break-in

The engine break-in period is essential to allow the various components of the engine to wear and polish themselves to the correct operating clearances. This ensures proper performance and promotes longer component life.

CAUTION:

- For the first tankful of operation, pre-mix a 50:1 mixture of fuel and oil (in addition to the oil in the oil tank).
- After break-in, use straight gasoline for normal operation.

1. Launch the watercraft and start the engine. (See pages 3-16 to 3-18 for engine starting procedures.)
2. Run the engine at the lowest possible speed for 5 minutes.



3. Gradually open the throttle to 3/4 or less.
4. Continue operation at 3/4 throttle or less until the first tankful of fuel has been used.
5. Fill the tank with straight gasoline, and then proceed with normal operation.

CAUTION:

Failure to follow the engine break-in procedure properly can result in severe damage to the engine.



EJU01247

Launching the watercraft

Make sure that there are no obstructions behind you.

After the watercraft is in the water, start the engine. Shift into reverse and move the watercraft back slowly. If there are waves, someone should make sure that the watercraft is not pushed into the trailer before backing away.

EJU01248

Starting the engine

⚠ WARNING

Never start the engine or let it run for any length of time in an enclosed area. Exhaust fumes contain carbon monoxide, a colorless, odorless gas that may cause loss of consciousness and death within a short time. Always operate the watercraft in an open area.

1. Launch the watercraft in water free from weeds and debris and at least 60 cm (2 ft) deep.

⚠ WARNING

Never operate in water that is less than 60 cm (2 ft) deep, otherwise you increase your chance of hitting a submerged object, which could result in injury.

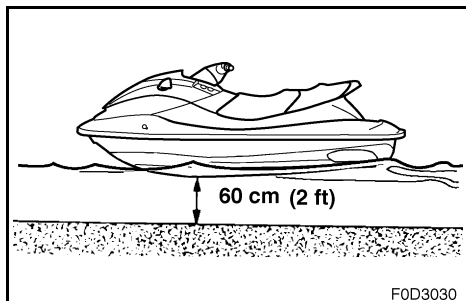

CAUTION:

Never operate in water that is less than 60 cm (2 ft) deep, otherwise pebbles or sand could be sucked into the jet intake, causing impeller damage or engine overheating.

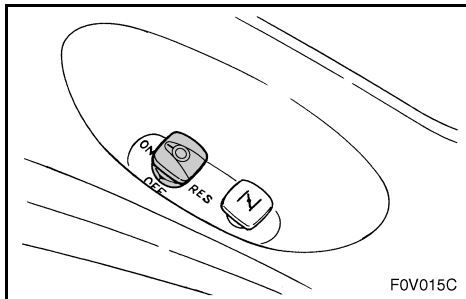

2. Turn the fuel cock knob to the “ON” position.

NOTE: _____
Before starting the watercraft, after it has been sitting, remove the fuel tank filler cap to release any built-up pressure in the tank due to fuel expansion.

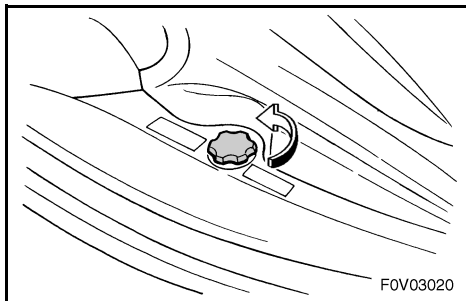

3. Attach the clip ① to the engine shut-off switch ②. Also, attach the engine shut-off cord ③ to your left wrist.

⚠WARNING _____

Check that the engine shut-off cord is not frayed or broken, and keep it free from the handlebars so the engine stops if the operator falls off. The engine shut-off cord may not pull free if wrapped around the handlebars when the operator falls off, allowing the watercraft to continue to run and cause an accident.

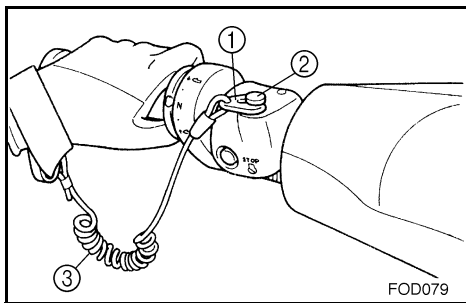

NOTE: _____
It is not possible to start the engine with the clip removed from the engine shut-off switch.

4. Pull and hold the choke knob all the way out to start a cold engine.

NOTE: _____
The choke should not be used when the engine is warm.

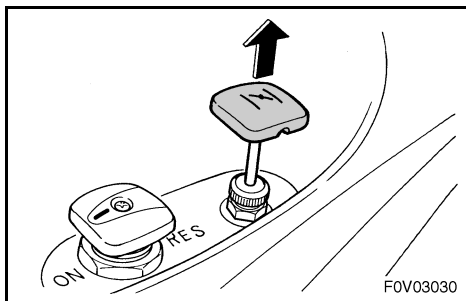



- If the "LOCK" mode was chosen previously, choose the "START" mode before starting the engine. (See pages 2-20 to 2-21 for selecting "PADLOC" mode.)

NOTE:

- If the initial setting of the PADLOC has not been done, the "START" mode is automatically selected.
- If you have previously chosen "LOCK" mode, the engine will not start unless the correct code is entered. This selects the "START" mode.

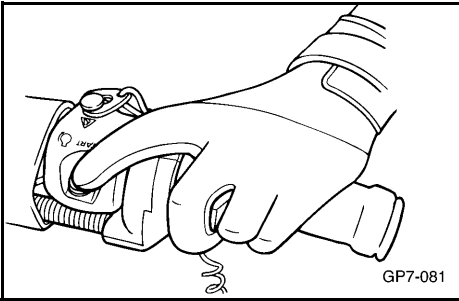

- While lightly squeezing the throttle lever, push the start switch (green button).

⚠ WARNING

On this watercraft, the engine is connected directly to the jet pump. Starting the engine immediately generates some thrust. Apply only enough throttle to keep the engine running.

- Release the start switch as soon as the engine starts to run.

CAUTION:

- Never push the start switch while the engine is running.
- Do not operate the start switch for more than 5 seconds, otherwise the battery will be discharged and the engine will not start. Also, the starter motor may be damaged. If the engine does not start in 5 seconds, release the start switch, wait 15 seconds, and try again.

- After the engine has warmed up, push the choke knob in to its original position.

NOTE:

If the choke knob is left pulled out, the engine will stall.

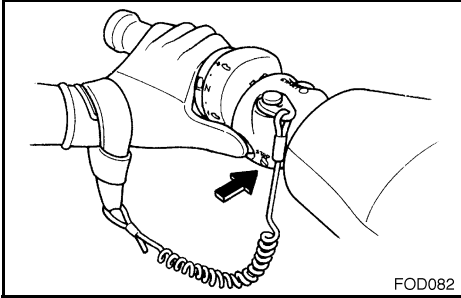

EJU01066

Stopping the engine

To stop the engine, release the throttle lever, and then push the engine stop switch (red button).

⚠WARNING

You need throttle to steer. Shutting off the engine can cause you to hit an obstacle you are attempting to avoid. A collision could result in severe injury or death.

EJU01249

Leaving the watercraft

If leaving the watercraft, choose the “LOCK” mode on the multifunction meter by setting PADLOC, and remove the engine shut-off cord to reduce the chance of accidental starting or unauthorized use by children or others.

To set the mode, see PADLOC under Multifunction meter.



EJU01068

Operating your watercraft

EJU01165

Getting to know your watercraft

Operating your watercraft requires skills acquired through practice over a period of time. Take the time to learn the basic techniques well before attempting more difficult maneuvers.

Operating your new watercraft can be a very enjoyable activity, providing you with hours of pleasure. However, it is essential to familiarize yourself with the operation of the watercraft to achieve the skill level necessary to enjoy riding safely. Before operating this watercraft, read this Owner's/Operator's Manual, the Riding Practice Guide, the Riding Instruction card and all warning and caution labels on the watercraft. Pay particular attention to the safety information on pages 1-8 to 1-15. Also, watch the Basic Orientation Video provided with your watercraft. These materials should give you an understanding of the watercraft and its operation.

Remember: This watercraft is designed to carry the operator and up to 2 passengers. Never exceed the maximum load limit or allow more than 3 persons (or 2 persons if a water-skier is being pulled) to ride the watercraft at one time.

Maximum load: 240 kg (530 lb)
Load is the total weight of cargo, operator and passengers.

EJU01191

Learning to operate your watercraft

Before operating the watercraft, always perform the pre-operation checks listed on page 3-5. The short time spent checking the watercraft will reward you with added safety and reliability.

Check state and local laws before operating your watercraft.

Operate defensively at safe speeds and keep a safe distance away from people, objects, and other watercraft. Select a wide area to learn in, where you have good visibility and light boat traffic.

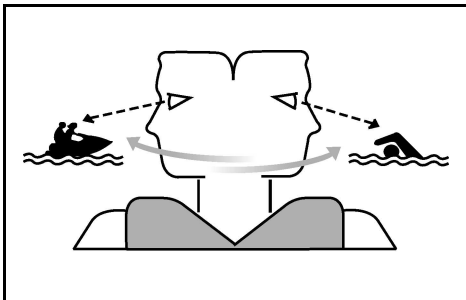

Use the buddy system—operate with someone nearby. Scan constantly for people, objects, and other watercraft. Be alert for conditions that limit your visibility or block your vision of others.

Attach the engine shut-off cord (lanyard) to your wrist and keep it free from the handlebars so that the engine stops if the operator falls off.

Wear a personal flotation device (PFD). All riders must wear a Coast Guard approved PFD that is suitable for personal watercraft use.



Wear protective clothing. Severe internal injuries can occur if water is forced into body cavities as result of falling into the water or being near the jet thrust nozzle. Normal swimwear does not adequately protect against forceful water entry into rectum and vagina. All riders must wear a wetsuit bottom or clothing that provides equivalent protection.

Such clothing includes thick, tightly woven, sturdy and snug-fitting apparel such as denim, but does not include spandex or similar fabrics like those used in bicycle shorts. A full wetsuit can also protect against hypothermia (subnormal body temperature) and abrasions.

Footwear and gloves are recommended.

Eye protection is recommended to keep wind, water, and glare from the sun out of your eyes while you operate your watercraft. Restraining straps for eyewear are made which are designed to float should your eyewear fall in the water.

You should grip the handlebars firmly and keep both feet on the floor of the footwell. Do not attempt to ride with passengers until your operating skills are fully developed.

EJU01166

Riding watercraft with passengers

When 2 or 3 persons (including the operator) are on board, the watercraft handles differently, and is not as easy to maneuver, so operating it requires a higher degree of skill. Before attempting to operate the watercraft with passengers on board, the operator must practice operating the watercraft alone enough to be able to acquire the necessary skills.

The passengers must always wear USCG approved PFD and wetsuit bottom or equivalent.

⚠WARNING

Do not apply throttle when anyone is at rear of watercraft. Turn engine off or keep engine at idle. Water and/or debris exiting the jet thrust nozzle can cause severe injury. Passengers should not attempt to board the watercraft if the operator is applying throttle.

Do not give a ride to children whose feet cannot reach the floor of the footwell. Passengers should hold on firmly to the person in front of them and keep both feet in the footwell.

⚠WARNING

When passengers are on board, make sure that they are holding on firmly and have feet in the footwell before you start to accelerate.

When pulling a skier, the spotter should face to the rear while holding the handgrip with both hands. The spotter should always sit astride the seat with his or her feet placed firmly on the footrest for proper balance. Follow state laws regarding skiing such as skier-down flags, rearward-facing spotter, and other requirements.



EJU01072

Starting the watercraft

⚠ WARNING

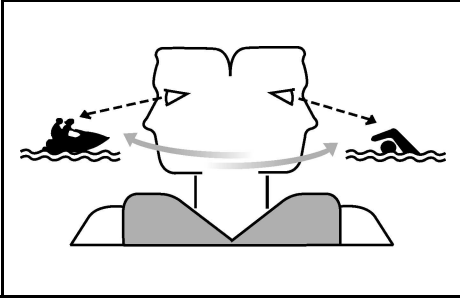

- Scan constantly for people, objects and other watercraft. Be alert for conditions that limit your visibility or block your vision of others.
- Operate defensively at safe speeds and keep a safe distance away from people, objects, and other watercraft.
- Do not follow directly behind watercraft or other boats. Do not go near others to spray or splash them with water. Avoid sharp turns or other maneuvers that make it hard for others to avoid you or understand where you are going. Avoid areas with submerged objects or shallow water.
- Take early action to avoid collisions. Remember watercraft and other boats do not have brakes. Do not release the throttle when trying to steer away from objects—you need throttle to steer.
- Practice reboarding in shallow water before riding in deep water.

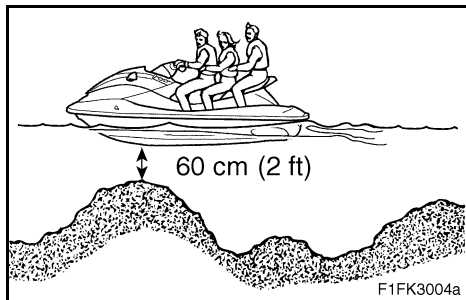

EJU01073

Starting and boarding in shallow water

1. Do not start the engine in less than 60 cm (2 ft) of water. Put the watercraft in water that is deep enough, and then board the watercraft from the side or the rear.
2. Attach the engine shut-off cord to your left wrist, and then install the clip to the engine shut-off switch.
3. Grip the handlebars with both hands, place both feet on the floor of the foot-well, start the engine, and start off.

EJU01074

Starting from a dock

1. Board the watercraft from the side.
2. Attach the engine shut-off cord to your left wrist, and then install the clip to the engine shut-off switch.
3. Push the watercraft away from the dock, grip the handlebars with both hands, place both feet on the floor of the foot-well, start the engine, and start off.



EJU01075

Boarding and starting in deep water

⚠WARNING

- Operator and passenger should practice getting on board in shallow water before riding in deep water. Boarding in deep water requires more skill.
- The fatigue and exposure that could result after unsuccessful attempts to get back on the watercraft may increase the risk of injuries and drowning.

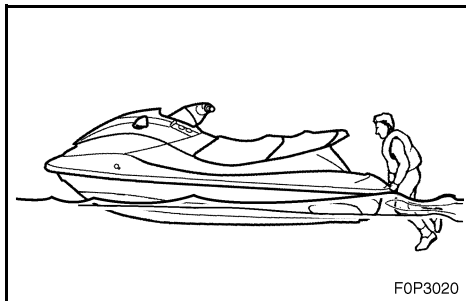

F0P3020

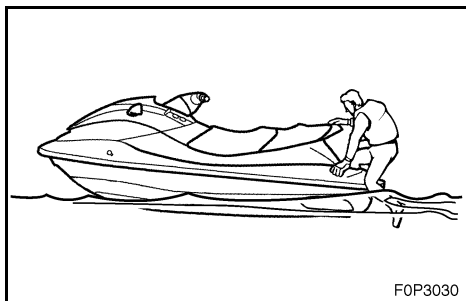

F0P3030

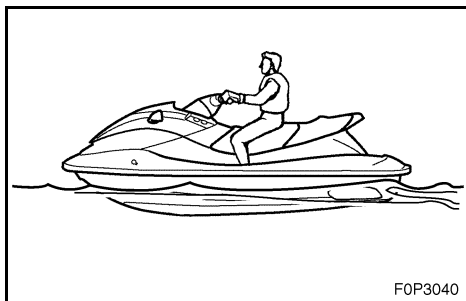

F0P3040

EJU01076

Boarding alone

1. Swim to the rear of the watercraft and place both hands on the boarding platform, pull yourself up, and then grasp the handgrip with one hand.
2. Pull yourself up to a kneeling position on the platform, and then move to the seat and sit astride.
3. Attach the engine shut-off cord to your wrist, and then install the clip to the engine shut-off switch.
4. Grip the handlebars firmly with both hands, place both feet in footwell, start the engine, and look in all directions before starting off.

⚠WARNING

Before starting off, make sure that there are no boats, obstructions, or swimmers around you.



EJU01252

Boarding with passengers

⚠WARNING

Severe internal injuries can occur if water is forced into body cavities as a result of being near the jet thrust nozzle. Do not apply throttle until each passenger is seated with his or her feet on the floor of the footwell and is holding on to the person in front of him or her.

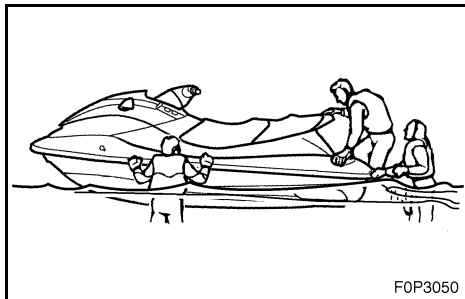

F0P3050

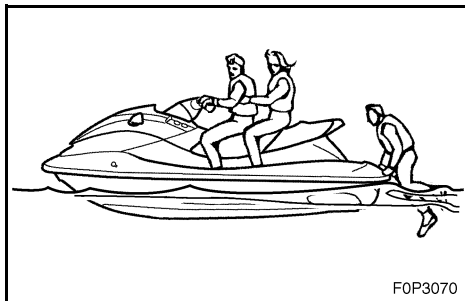

F0P3070

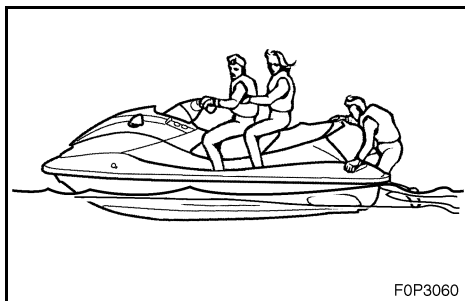

F0P3060

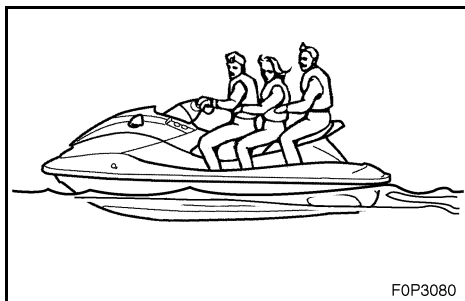

F0P3080

1. Climb on board as noted in the previous section, and sit astride the seat. Attach the engine shut-off cord to your wrist, and then install the clip to the engine shut-off switch.
2. Have the passenger move to the rear of the watercraft.
3. Have the passenger get on board and sit on the seat. If a second passenger is getting on, have him or her follow the same procedure.

NOTE:

When a passenger is getting on board, both he and the operator should try to balance the watercraft.

4. The operator should check to see that the passengers have their feet on the floor of the footwell and that they are securely holding on to the person in front of them.
5. Start the engine, look in all directions, and then accelerate to planing speed.

⚠WARNING

Before starting off, make sure that there are no boats, obstructions, or swimmers around you.

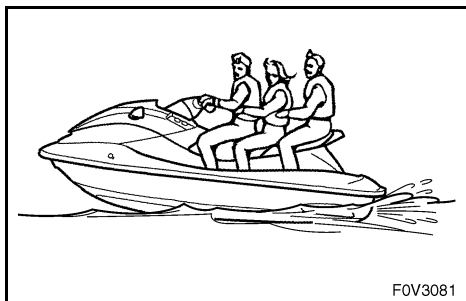
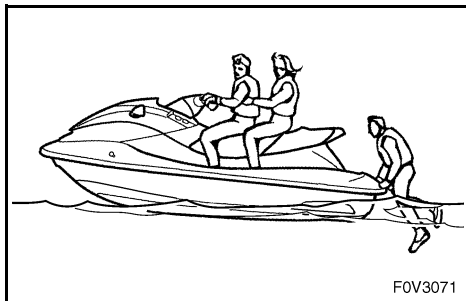
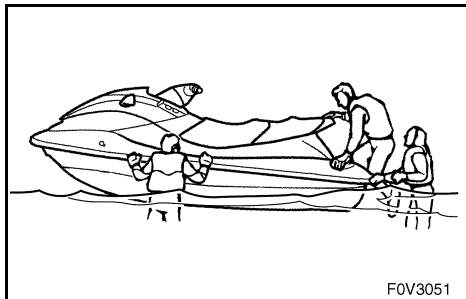
**NOTE:**

The heavier the total weight of the operator and passengers, the more difficult it will be to balance the watercraft. Do not operate the watercraft when the total weight exceeds 240 kg (530 lb) including any cargo. If it is difficult to balance the watercraft at a standstill, proceed as follows:

1. The passenger must steady the watercraft while the operator is boarding. The operator pulls himself up onto the platform into a seating position, then balances the watercraft.
2. Attach the lanyard to your left wrist, then install the clip on the lanyard to the engine shut-off switch. Start the engine and keep it at idle.
3. The passenger pulls himself up on the platform, kneels down, then crawls onto the seat as the watercraft accelerates.
4. The watercraft can now be accelerated to planing speed, then the operator can reduce the throttle to the desired running speed.

EJU01078

Capsized watercraft

If the watercraft capsizes, follow the procedures below carefully to prevent damage or injury.

⚠WARNING**IMPROPER UPRIGHTING CAN CAUSE INJURY:**

- Shut engine off, and be sure engine shut-off cord is removed from the engine shut-off switch.
- Do not put hand in intake grate.
- Watch so you are not hit by the watercraft as it comes over.

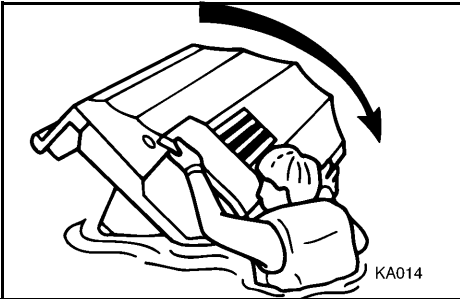
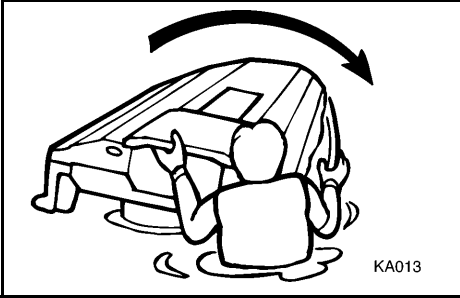
**CAUTION:**

Be sure to remove the clip from the engine shut-off switch, otherwise the engine will overheat and engine damage may occur.

1. Shut the engine off by removing the clip from the engine shut-off switch.
2. Swim to the rear of the watercraft. Pull the watercraft over with left hand on ride plate while pushing down on the gunwale with your right hand/foot.

NOTE:

If the port side of the capsized watercraft is tilting upward, first tilt the watercraft so the port side is down by using your weight to press down on the gunwale.

CAUTION:

Do not turn the watercraft over counter-clockwise, otherwise water may leak into the carburetor and engine and cause damage.

3. Start the engine, and then head for shore to inspect the engine for water damage.

CAUTION:

If the watercraft has been capsized for 5 minutes or more, air may have entered the oil injection system. Leave the engine off, or operate only at trolling speed, for 10 minutes after the watercraft has been turned right-side up. This will allow any air to bleed off.



EJU01079

Turning the watercraft

Steering control depends on the combination of handlebar position and the amount of throttle.

Water sucked in through the intake grate is pressurized by the impeller in the jet pump. As the pressurized water is expelled from the pump through the jet thrust nozzle, it creates thrust to move and steer the watercraft. The higher the engine speed, the more thrust is produced.

The amount of jet thrust, in addition to the position of the handlebars, determines how sharply you turn.

- A. More throttle produces higher thrust, so the watercraft will turn more sharply.
- B. Less throttle produces lower thrust, so the watercraft will turn more gradually.
- C. Releasing the throttle completely produces only minimum thrust. If you are traveling at speeds above trolling, you will have rapidly decreasing ability to steer without throttle. You may still have some turning ability immediately after releasing the throttle, but once the engine slows down, the watercraft will no longer respond to handlebar input until you apply throttle again or you reach a trolling speed.

At trolling speed, the watercraft can be turned gradually by handlebar position alone using just the amount of thrust available at idle.

- D. If the engine is stopped while riding, there is no thrust. The watercraft will go straight even though the handlebars are turned.

You need throttle to steer.

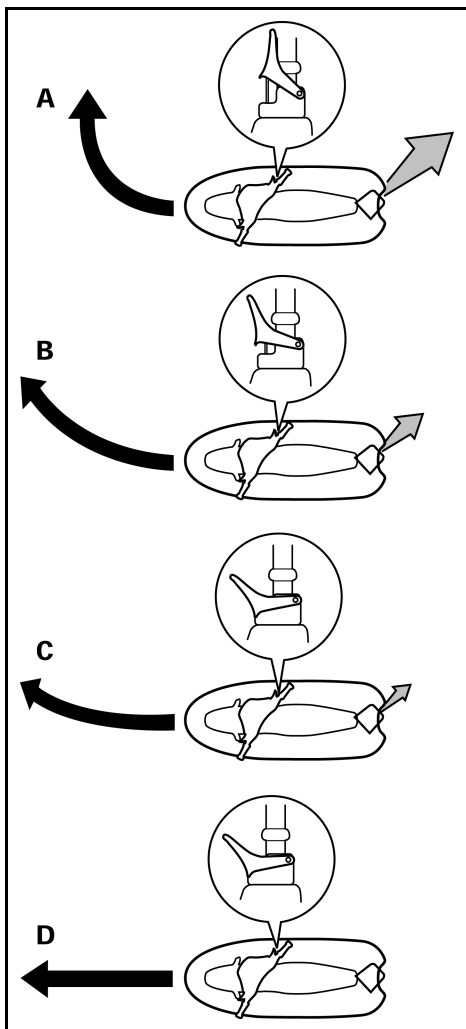
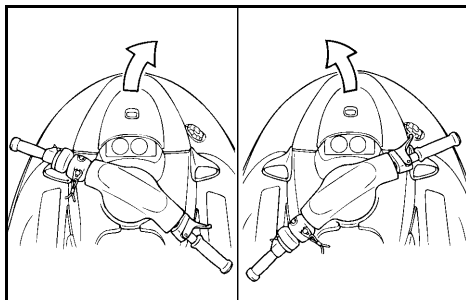



⚠ WARNING

- Do not release the throttle when trying to steer away from objects—you need throttle to steer. A collision could result in severe injury or death.
 - When operating at higher speeds, make gradual turns or slow down before turning. Sharp high-speed turns may cause the watercraft to slide sideways or spin, throwing the operator and passengers overboard which could cause an injury.
-



EJU01253

Stopping the watercraft

The watercraft is not equipped with a separate braking system. It is stopped by water resistance when the throttle lever is released. From full speed, the watercraft comes to a complete stop in approximately 105 m (345 ft) after the throttle is released and the engine is stopped, although this distance will vary depending on many factors, including gross weight, water surface conditions, and wind direction. The watercraft slows down as soon as the throttle lever is released, but will coast for a distance before fully stopping. If you are not sure you can stop in time before hitting an obstacle, apply throttle and turn in another direction.

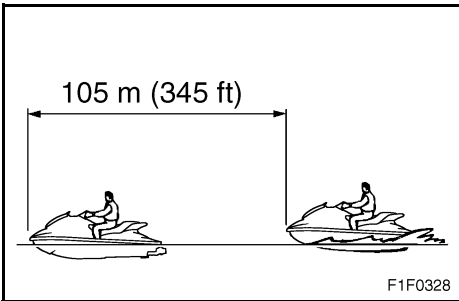

⚠ WARNING

- Allow adequate stopping distance.
- Take early action to avoid collisions. Remember, watercraft and other boats do not have brakes.
- Operate defensively at safe speeds and keep a safe distance away from people, objects, and other watercraft to give you time to stop.
- Do not shut the engine off when slowing down in case you need engine power to steer away from a boat or other obstacle that comes into your path.

⚠ WARNING

Do not use the reverse function to slow down or stop the watercraft as it could cause you to lose control, be ejected, or impact the handlebars.



EJU01081

Beaching the watercraft

1. Make sure no obstructions, boats or swimmers are near the beach. Release the throttle lever about 105 m (345 ft) before you reach the intended beaching area.
2. Approach the beach slowly and stop the engine before reaching land.
Remember: you need throttle to steer.
3. Get off the watercraft and pull it up on the beach.

CAUTION:

Small pebbles, sand, seaweed, and other debris can be pulled into the jet intake and impair or damage the impeller. Always stop the engine and get off before beaching the watercraft.

EJU01082

Docking the watercraft

1. Make sure that no obstructions, boats or swimmers are close to the watercraft. Reduce speed about 105 m (345 ft) away from the dock.
2. Slowly approach the dock and stop the engine just before coming alongside it.

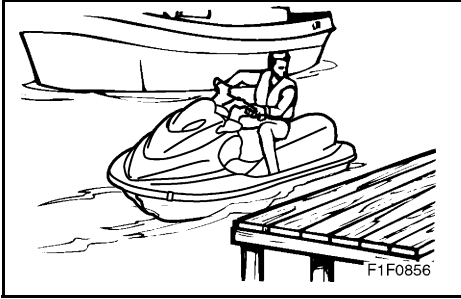

EJU01254

Reverse on waterways

Reverse can be used for slow speed maneuvering when it is necessary to back up out of tight spots where you cannot turn around. Reverse can only be used to slow down or stop during low speed maneuvering, such as when docking.

Once the engine is idling, shift to reverse and gradually increase engine speed. Make sure that there are no obstacles or people behind you before shifting to reverse.

EJU01255

Rough water operation

The force of landing after jumping can cause a strong impact on both the watercraft and the operator and passengers. It is possible for the operator to hit his or her chest or jaw on the watercraft body or handlebars and be injured. Do not operate the watercraft with your chin right above the handlebars or with your feet outside the watercraft. Operating in rough water or jumping waves can also crack the watercraft body or damage internal parts. Avoid operating in rough water or bad weather conditions.



EJU01384

Post-operation checks

Always perform the following post-operation checks after operating the watercraft.

1. Remove the watercraft from the water.
2. Wash down the hull, handlebars, and jet unit with fresh water.
3. Remove the seat and check the engine compartment for water. To drain excess water, remove the stern drain plugs, then raise the bow of the watercraft enough to allow water in the bilge to drain out.

NOTE:

This watercraft is equipped with an automatic bilge-draining system that removes water from the engine compartment while you are underway. However, some residual water will remain.

4. Put the watercraft in a horizontal position.
5. Flush the cooling system to prevent it from clogging with salt, sand, or dirt. (See page 4-1 for flushing the cooling system procedures.)
6. Drain residual water from the exhaust system by alternately squeezing and releasing the throttle lever for 10 to 15 seconds while the engine is running.

CAUTION:

Do not attempt to run the engine at full throttle or for more than 15 seconds while the watercraft is out of the water, otherwise the engine may overheat or seize.

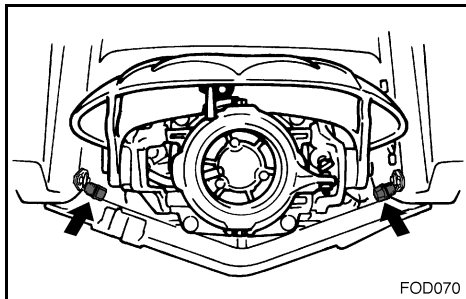



7. If the watercraft will be stored for a week or more, lubricate internal engine components to help prevent corrosion. (See page 4-3 for lubrication procedures.)
8. Rinse the engine and engine compartment with a small amount of water.

CAUTION:

Do not use high pressure when rinsing the engine or engine compartment as severe engine damage could result.

9. Wipe the engine and engine compartment dry with a clean cloth (repeat step 3, if necessary).
10. Wipe the hull, handlebars, and jet unit dry with a clean cloth.
11. Spray a rust inhibitor, such as Yamaha Silicone Protectant and Lubricant, on metallic parts to minimize corrosion.
12. Allow the engine compartment to air dry completely before reinstalling the seat.



EJU01256

Transporting

⚠ WARNING

Always place the fuel cock knob in the “OFF” position when transporting the watercraft, otherwise fuel could leak out into the engine or engine compartment, which would create a fire hazard.

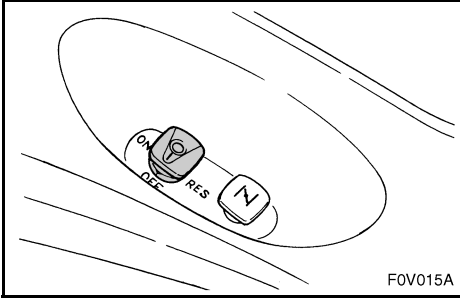

When transporting the watercraft on a trailer, secure the tie downs to the trailer through the bow eye and stern rope hole.

CAUTION:

- Do not route ropes or tie downs over the seat, as they may leave permanent marks on the seat's surface. Also, wrap the ropes or tie downs with towels or rags where they touch the body of the watercraft to avoid scratching or damage.
- Before putting the watercraft on the trailer or transporting it, be sure to put the shift lever in the forward position, otherwise the reverse gate may hit an obstruction, which may cause damage.

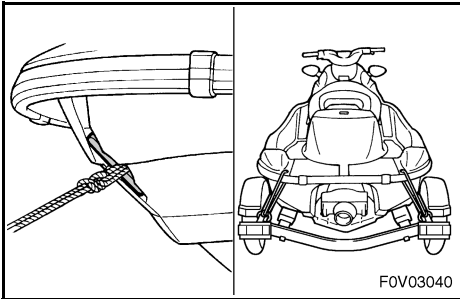

EJU01086

MAINTENANCE AND CARE



Storage	4-1
Flushing the cooling system	4-1
Lubrication	4-3
Fuel system	4-4
Battery	4-5
Cleaning the watercraft	4-6
Maintenance and adjustments	4-7
Owner's/Operator's Manual and tool kit	4-8
Periodic maintenance chart.....	4-9
Inspecting the fuel system	4-10
Inspecting the oil injection system	4-12
Inspecting the steering cable	4-13
Inspecting the shift cable	4-13
Inspecting and adjusting the throttle cable	4-13
Inspecting the QSTS mechanism	4-14
Cleaning and adjusting the spark plugs	4-15
Lubrication points	4-16
Adjusting the choke cable	4-19
Inspecting the battery	4-20
Adjusting the carburetor	4-22
Replacing the fuse	4-23
Bleeding the oil injection pump	4-23
Specifications	4-24



EJU01087

Storage

⚠ WARNING

Always place the fuel cock knob in the “OFF” position when storing the watercraft, otherwise fuel could leak out into the engine or engine compartment, which would create a fire hazard.

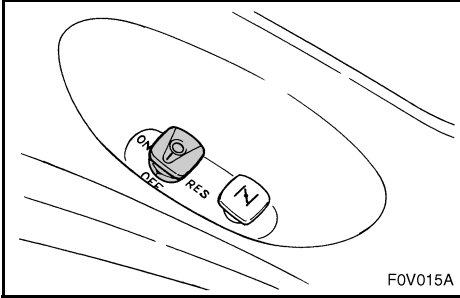

Storage for prolonged periods of time, such as winter storage, requires preventative maintenance to ensure against deterioration. It is advisable to have the watercraft serviced by a Yamaha dealer prior to storage. However, the following procedures can be performed by the owner.

EJU01088

Flushing the cooling system

Flushing the cooling system is essential to prevent the cooling system from being clogged with salt, sand, or dirt.

CAUTION:

- Do not supply water to the cooling water passages when the engine is not running. The water could flow back through the muffler into the crankcase causing severe engine damage.
- Do not run the engine for more than 15 seconds without supplying water, otherwise the engine may overheat.

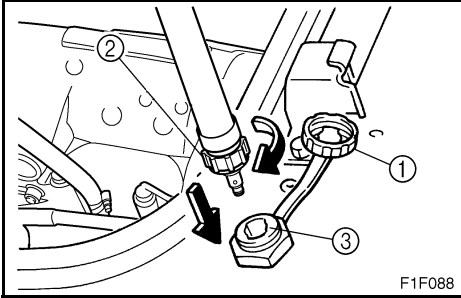

1. Put the watercraft on land in a horizontal position.
2. Open the flushing hose connector cap ①, and then insert the garden hose adapter ② into the flushing hose connector ③ and turn it until it is securely connected.
3. Connect the garden hose adapter to a water tap using a hose.
4. Start the engine, and then immediately turn the water supply on until water flows out continually from the cooling water pilot outlet.
5. Run the engine at idling speed for about 3 minutes watching the engine condition. If the engine stops while flushing, turn the water supply off immediately and repeat the above steps.
6. Turn the water supply off, and then force the remaining water out from the cooling passages by alternately squeezing, and releasing the throttle lever for 10 to 15 seconds.
7. Stop the engine.
8. Remove the garden hose adapter and secure the cap.



EJU01152

Lubrication

⚠ WARNING

To reduce the risk of fire or explosion:
Never pour or spray gasoline, or any substance other than a rust inhibitor through the hole in the carburetor silencer cover.

CAUTION:

- Make sure to replace the cap securely after fogging the engine, otherwise water could enter the engine and cause damage.
- Do not attempt to run the engine at full throttle or for more than 15 seconds while the watercraft is out of the water, otherwise the engine may overheat and/or seize.

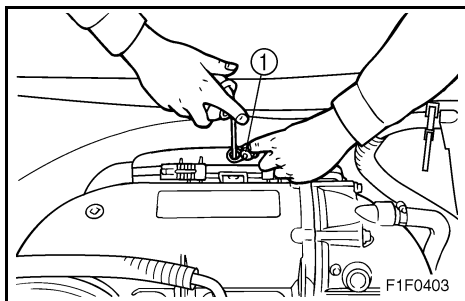

1. Open the silencer cap ① on the silencer.
2. Start the engine with the watercraft in a well-ventilated area.
3. With the engine running at a fast idle, quickly spray as much rust inhibitor as possible through the hole in the silencer cover. Use Yamaha Stor-Rite Fogging Oil or an equivalent. Keep spraying until the engine stalls (or a maximum of 15 seconds).
4. Install the cap securely.
5. Lubricate all cables such as the throttle, choke, and steering cables.

NOTE:

Use a Yamaha Power Cable Luber and Yamaha Lube-Zall to pressure lubricate the cables and purge out any moisture between the inner and outer cables.

6. Lubricate the areas of the watercraft specified under Lubrication points on page 4-16.



EJU01168

Fuel system

Top off the fuel tank with fresh gasoline and add one ounce of Yamaha Fuel Stabilizer and Conditioner to each gallon of fuel.

NOTE: _____

Use of Yamaha Fuel Stabilizer and Conditioner eliminates the need to drain the fuel system. If the fuel system is to be drained instead, consult a Yamaha dealer.



EJU01092

Battery

If the watercraft is not used for a month or more, disconnect the (-) battery cable first, and then the (+) cable and breather pipe, and next remove the battery from the craft.

Clean the battery casing using fresh water.

If the battery terminals are dirty or corroded, clean the mating surfaces on the terminals for the battery cables using the wiring brush or equivalents.

Recharge the battery, and then store it in a cool and dark place.

Apply the Yamaha marine grease/Yamaha grease A to the battery terminals.

Recharge the battery periodically at least 2 months because a battery will discharge electricity by itself while storing.

CAUTION:

The battery may be impossible to use again if you store it for a longer time without recharging. Recharge the battery periodically.

NOTE:

The battery condition can be found by checking the specific gravity of the electrolyte. However, you can also know the battery condition roughly by measuring the voltage at both battery terminals. Recharge the battery if the voltage is 12 volts or less.

Specific gravity of electrolyte (for reference): 1.28 at 20 °C (68 °F)
--

Yamaha recommend checking the specific gravity of the electrolyte and charging battery by a Yamaha dealer or a battery dealer. If you maintain the battery yourself, read carefully the instructions for the tool and machine before maintenance.



EJU01169

Cleaning the watercraft

Clean the watercraft before storing it for a long period.

1. Wash down the hull, handlebars, and drive unit with fresh water.
2. Rinse the engine and bilge area with fresh water. Drain off all water and wipe up remaining moisture with clean, dry rags.
3. Spray the engine's exterior with Yamaha Silicone Protectant and Lubricant.
4. Wax the hull with a non-abrasive wax such as Yamaha Silicone Wax.
5. Wipe all vinyl and rubber components, such as the seat and engine compartment seals, with a vinyl protectant such as Yamaha Protectant.



Maintenance and adjustments

Periodic inspection, adjustment and lubrication will keep your watercraft in the safest and most efficient condition possible. Safety is an obligation of the watercraft owner. The most important points of watercraft inspection, adjustment and lubrication are explained on the following pages.

See your Yamaha dealer for genuine Yamaha replacement parts and optional accessories designed for your watercraft.

Remember that failures that are the result of the installation of parts or accessories which are not qualitatively equivalent to genuine Yamaha parts are not covered by the limited warranty.

⚠ WARNING

- **Be sure to turn off the engine when you perform maintenance unless otherwise specified, otherwise an accident or injury could result from unexpected operation, moving parts, or electric shock. If the owner is not familiar with watercraft servicing, this work should be done by a Yamaha dealer. Improperly serviced components could fail or stop operating correctly, which could result in an accident.**
- **Modifications to this watercraft not approved by Yamaha may cause loss of performance or excessive noise, or render it unsafe for use. Consult a Yamaha dealer before attempting any changes.**



NOTE: _____
A service manual is available for purchase through a Yamaha dealer for owners who have the mechanical skills, tools, and other equipment necessary to perform maintenance not covered by this Owner's/Operator's Manual.

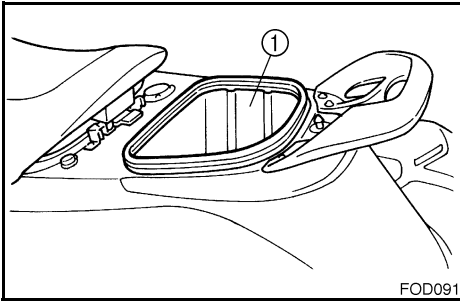

EJU01198

Owner's/Operator's Manual and tool kit

It is advisable always to carry the Owner's/Operator's Manual and tool kit ② with you whenever you use the watercraft. For your convenience, a storage compartment ① is provided on the watercraft for the manual and tool kit.

NOTE: _____
To protect these materials from water damage, it would be a good idea to put them in a waterproof bag. If your Owner's/Operator's Manual is damaged, order a replacement from a Yamaha dealer.

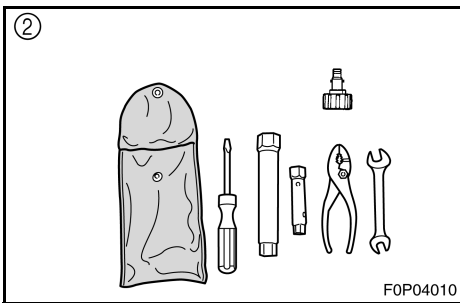

The service information included in this manual is intended to provide you with the necessary information for completing your own preventive maintenance and minor repairs. The tools provided in the tool kit are sufficient for this purpose. However, a torque wrench may also be necessary to tighten nuts and bolts.



EJU01357

Periodic maintenance chart

The following chart gives general guidelines for periodic maintenance. However, depending on your operating conditions maintenance may need to be performed more frequently.

- (●) This mark indicates maintenance that you may do yourself.
- (○) This mark indicates work to be done by a Yamaha dealer.

MAINTENANCE INTERVAL ITEM		INITIAL			THEREAFTER EVERY		PAGE
		10 hours	50 hours	100 hours	100 hours	200 hours	
			3 months	6 months	6 months	12 months	
Spark plug	Inspect, clean, adjust	●	●	●	●		4-15
Lubrication points	Lubricate			●	●		4-16
Intermediate housing	Lubricate	○*1		●*2	●*2		4-19
Fuel system	Inspect			○	○		4-10
Fuel filter	Check, replace	○				○	4-11
Fuel tank	Clean					○	4-11
Oil injection system	Inspect, clean	○				○	4-12
Trolling speed	Adjust			●	●		4-22
Carburetor throttle shaft	Inspect			○	○		—
Cooling water passages	Flush	● (after every use)					4-1
Bilge strainer	Clean		●	●	●		—
Impeller	Inspect		●	●	●		—
Steering cable	Inspect			●	●		4-13
Steering master	Inspect	○		○	○		—
QSTS mechanism	Inspect			●	●		4-14
Shift cable and mechanism	Inspect, adjust			●	●		4-13
Throttle cable	Inspect, adjust			●	●		4-13
Choke cable	Inspect, adjust			●	●		4-19
Stern drain plugs	Inspect, replace					●	3-7
Battery	Inspect	● (inspect fluid level before every use)					4-20
Rubber coupling	Inspect					○	—
Nuts and bolts	Retighten	○		○	○		—

*1: Grease capacity: 33.0–35.0 cm³ (1.11–1.18 oz)

*2: Grease capacity: 6.0–8.0 cm³ (0.20–0.27 oz)



EJU01383

Inspecting the fuel system

⚠WARNING

Gasoline is highly flammable and explosive. A fire or explosion can cause severe injury or death. Shut off the engine. Do not smoke. Avoid spilling gasoline.

Check the fuel system for leaks, cracks, or malfunctions. If any problem is found, do the necessary repair or replacement as required. If repair is necessary, consult a Yamaha dealer.

Check:

- Carburetor for leakage.
- Fuel pump for malfunction or leakage.
- Fuel tank for water or dirt.
- Fuel tank for damage, cracks or leakage.
- Fuel hose joint for leakage.
- Fuel hose for cracks or other damage.
- Fuel filter for leakage.
- Fuel cock for leakage.
- Air vent check valve for leakage.
- Fuel tank filler cap for damage.

⚠WARNING

Failure to check for and repair any fuel leakage may result in fire or explosion.

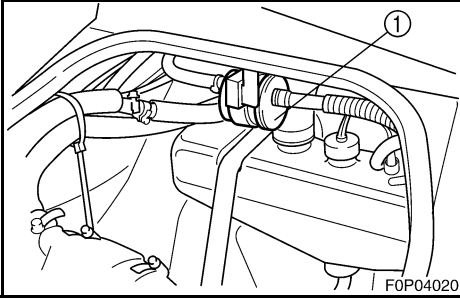

EJU01098

Fuel filter

This watercraft is equipped with a one-piece, disposable fuel filter ①. The fuel filter should be replaced once a year or after every 200 hours of operation, or if water is found in the filter. Have a Yamaha dealer replace the fuel filter if necessary.

⚠WARNING

Do not try to replace the fuel filter yourself. An incorrectly installed filter can leak gasoline, which could lead to fire or explosion. If necessary, have a Yamaha dealer replace the fuel filter.

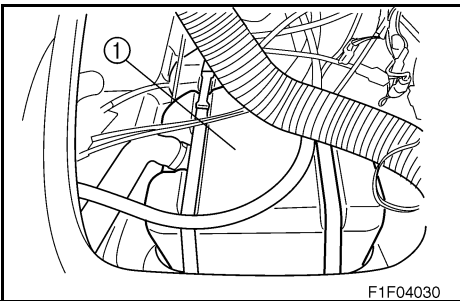

EJU01099

Fuel tank

Check the fuel tank ① for leakage or water in the tank. If water is found in the fuel system or if the fuel tank needs to be cleaned have a Yamaha dealer service the watercraft.



EJU01100

Inspecting the oil injection system

Check the oil injection system for leakage, cracks, or malfunctions. If necessary, have a Yamaha dealer repair the oil injection system.

Check:

- Oil tank for damage, cracks or leakage.
- Oil tank for water or dirt.
- Oil hose and joint for damage or cracks.
- Oil filter for dirt.
- Oil pump for leakage.

EJU01101

Oil tank

Check the oil tank for leakage or water in the tank. If water is found in the oil injection system or if the oil tank needs to be cleaned have a Yamaha dealer service the watercraft.

EJU01102

Oil filter

Check the oil filter ① for dirt and clogs. If the oil filter is clogged, remove it from the oil tank together with the oil level sender and clean it.

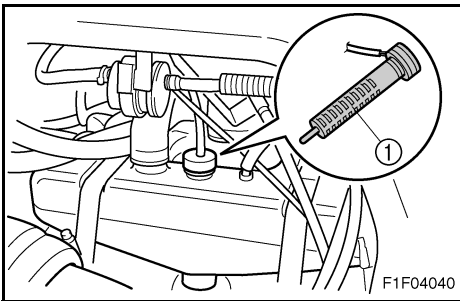

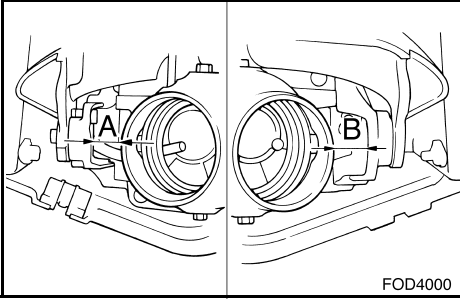

FOD4000

EJU01258

Inspecting the steering cable

Check for smooth operation of the handlebars and jet thrust nozzle.

Turn the handlebars as far as possible to the right and left and check that the distance between the jet thrust nozzle and the bracket of the reverse gate are equal on right and left sides.

Distance A and B: $A=B$

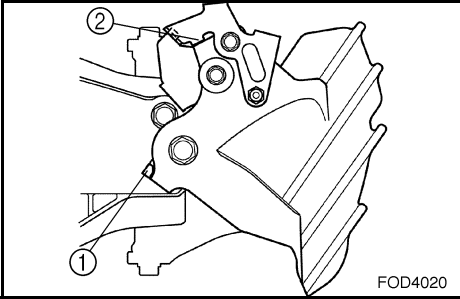

FOD4020

EJU01259

Inspecting the shift cable

Place the shift lever in the reverse position.

Make sure the gate makes contact with the stopper ① on the bracket, and the arm ② makes contact with the reverse gate.

If the reverse gate does not reach the correct positions, have a Yamaha dealer service it.

EJU01104

Inspecting and adjusting the throttle cable

Check that the throttle cable moves back to the set position smoothly and that free play is within specification.

1. Squeeze and release the throttle lever. If the lever does not return smoothly, have a Yamaha dealer service it.
2. Adjust free play ② by loosening the lock-nut ① and turning the adjuster ②.

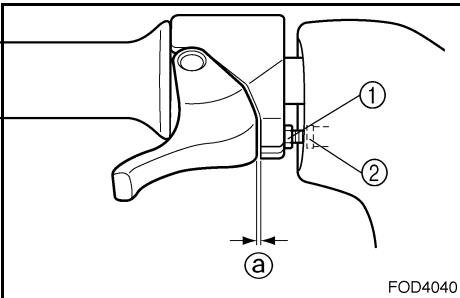

FOD4040

Throttle lever free play:
4–7 mm (0.16–0.28 in)



EJU01105

Inspecting the QSTS mechanism

Check that the shift lock lever moves back to the lock position smoothly, that the QSTS selector locks and unlocks properly, and that the jet thrust nozzle moves up or down.

1. Squeeze and release the shift lock lever.
2. Check that the QSTS selector locks and unlocks when the lever is released.
3. Check that the selector turns smoothly when the lever is squeezed and held in place.
4. Check that the angle of the jet thrust nozzle changes when the selector is shifted from neutral to bow-up or bow-down.

If the mechanism does not work properly, have a Yamaha dealer service it.

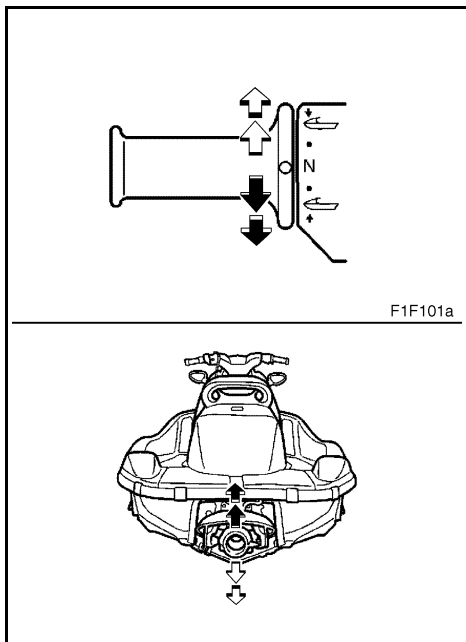
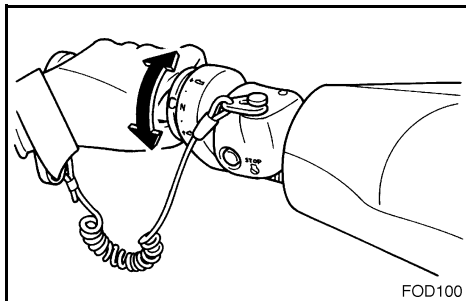
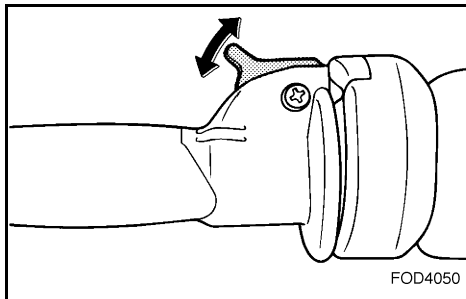



EJU01341

Cleaning and adjusting the spark plugs

The spark plug is an important engine component and is easy to inspect. The condition of the spark plug can indicate something about the condition of the engine. For example, if the center electrode porcelain is very white, this could indicate an intake air leak or carburetion problem in that cylinder. Do not attempt to diagnose any problems yourself. Have a Yamaha dealer service the watercraft.

Remove and inspect the spark plug periodically; heat and deposits will cause the spark plug to slowly break down and erode. If electrode erosion becomes excessive, or if carbon and other deposits are excessive, replace the spark plug with the specified plug.

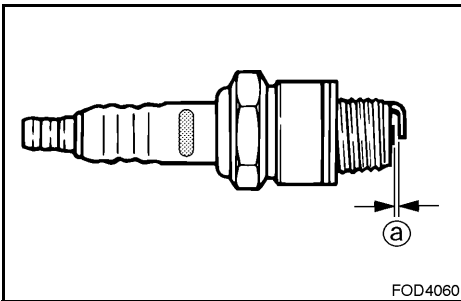

Standard spark plug: BR8ES

Measure the spark plug gap $\text{\textcircled{a}}$ with a wire thickness gauge before installing the spark plug. Adjust the gap to specification if necessary.

Spark plug gap:
0.7–0.8 mm (0.028–0.031 in)

To reinstall spark plug:

1. Clean the gasket surface.
2. Wipe any dirt from the threads of the spark plug.
3. Screw the spark plug to the correct torque.

Spark plug torque:
25 N·m (2.5 kgf·m, 18 ft·lb)

**NOTE:**

- Wipe off any water on the spark plug or inside the cap before installing the spark plug cap. Push the spark plug cap down until it clicks.
- If a torque wrench is not available when you are fitting a new spark plug, a good estimate of the correct torque is 1/4 turn to 1/2 turn past finger tight. Have the spark plug adjusted to the correct torque with a torque wrench as soon as possible.

⚠WARNING

Be careful not to damage the insulator when removing or installing a spark plug. A damaged insulator could allow sparks to escape, which could lead to explosion or fire.

EJU01260

Lubrication points

To keep moving parts sliding or rotating smoothly, coat them with water-resistant grease.

Recommended water-resistant grease:
Yamaha Marine Grease/
Yamaha Grease A

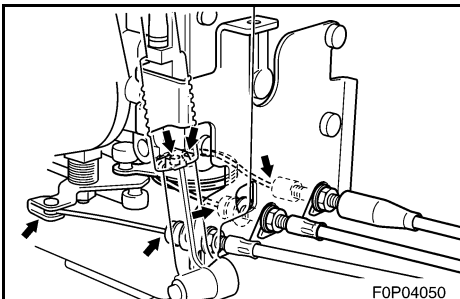

- Throttle cable (carburetor end)
- Oil pump cable
- Choke cable (carburetor end)

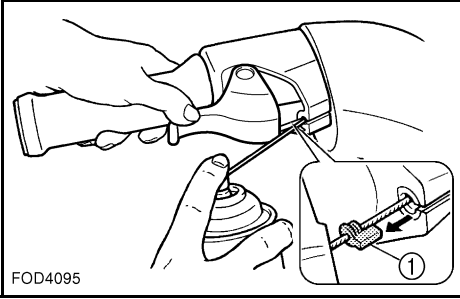

FOD4095

- Throttle cable (handlebar end)
Pull the throttle lever and remove the seal ①.
Spray a rust inhibitor into the outer cable. Refit the seal securely.

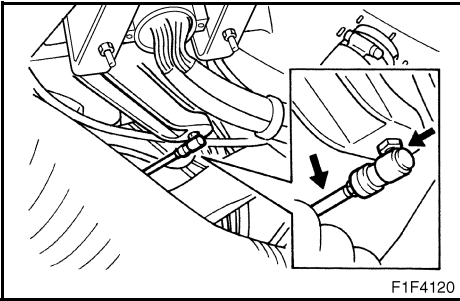

F1F4120

- Steering cable (handlebar end)

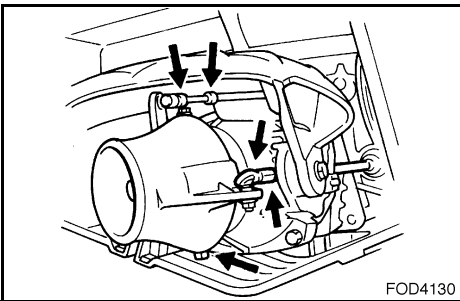

FOD4130

- Steering cable (nozzle end)
- Nozzle pivot shaft
- QSTS cable (nozzle end)

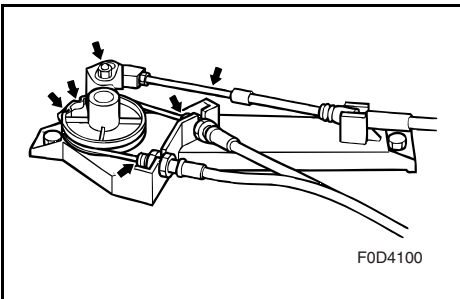

FOD4100

- QSTS cables (pulley end)

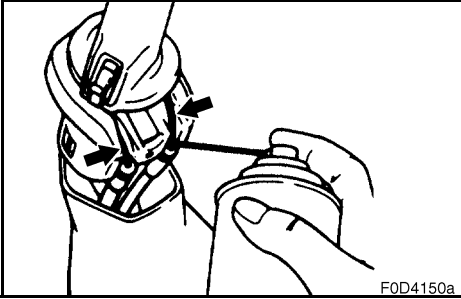

- QSTS cables (handlebar end)
Remove the QSTS cable housing. Spray a rust inhibitor into the outer cable. Reinstall the QSTS cable housing.

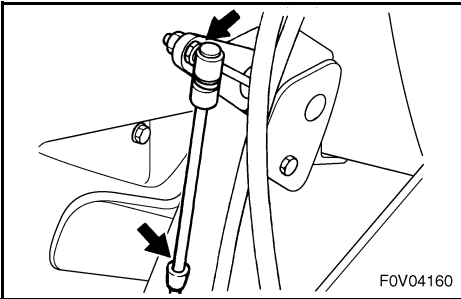

- Shift cable (lever end)

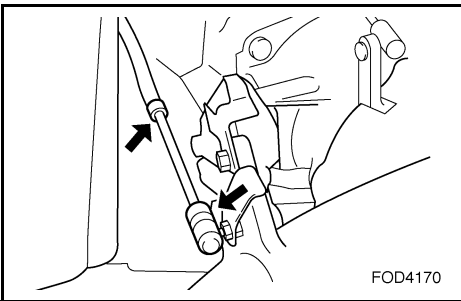

- Shift cable (reverse gate end)

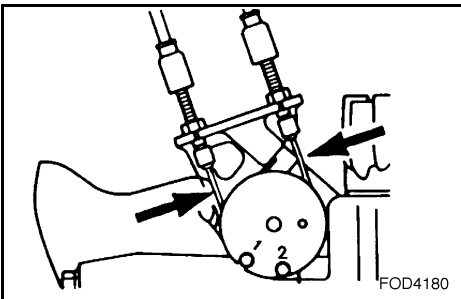

- YPVS cable

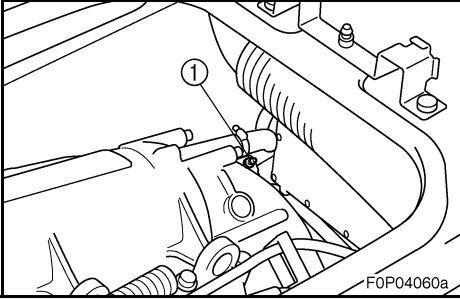

- Intermediate housing

Using a grease gun, fill the intermediate housing with water-resistant grease through the grease nipple ①.

Grease capacity:

Initial 10 hours or 1 month:

33.0–35.0 cm³ (1.11–1.18 oz)

Every 100 hours or 6 months:

6.0–8.0 cm³ (0.20–0.27 oz)

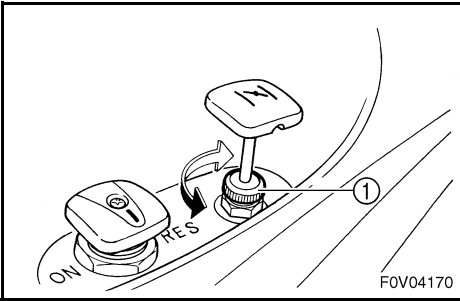

EJU01261

Adjusting the choke cable

Check that the choke cable is properly adjusted.

1. Pull the choke knob out until it stops, and then release the knob. The knob should not move.
2. If the choke knob moves back on its own, tighten the choke knob adjusting nut ① slightly. If the knob is difficult to move, loosen the adjusting nut slightly.



EJU01108

Inspecting the battery

Check the level of the battery electrolyte and make sure the leads are secure.

⚠WARNING

Battery electrolyte is poisonous and dangerous, causing severe burns, etc. Electrolyte contains sulfuric acid. Avoid contact with skin, eyes or clothing.

Antidotes

External: Flush with water.

Internal: Drink large quantities of water or milk. Follow with milk of magnesia, beaten egg or vegetable oil. Call physician immediately.

Eyes: Flush with water for 15 minutes and get prompt medical attention.

Batteries produce explosive gases. Keep sparks, flame, cigarettes, etc., well away. If using or charging the battery in an enclosed space, make sure that it is well ventilated. Always shield your eyes when working near batteries.

KEEP OUT OF THE REACH OF CHILDREN.

CAUTION:

Be careful not to place the battery on its side.

Make sure to remove the battery from the battery compartment when adding battery electrolyte or charging the battery.

When checking the battery, make sure the breather hose is connected to the battery and not obstructed.

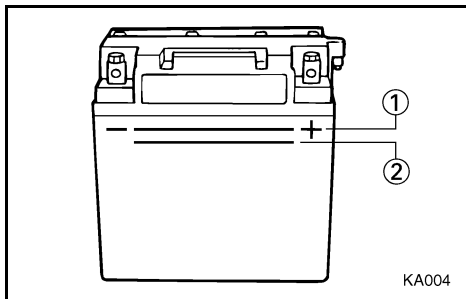
**To replenish the battery:**

1. Make sure that the electrolyte level is between the upper ① and lower ② level marks.
2. Refill the battery with distilled water if necessary.

CAUTION:

Normal tap water contains minerals that are harmful to a battery. Use only distilled water for replenishing the battery.

To recharge the battery:**CAUTION:**

Do not attempt to charge a battery hastily. Battery life may be shorter.

Yamaha recommend charging battery by a Yamaha dealer or a battery dealer. If you charge the battery yourself, read the battery charger instructions carefully before charging and follow the points below.

1. Remove all caps from the battery cell.
2. Add distilled water to the specified level if the electrolyte level is low.
3. Set the charging rate to 1.9 ampere and charge the battery slowly until the explosive gases become coming out vigorously from battery cells.

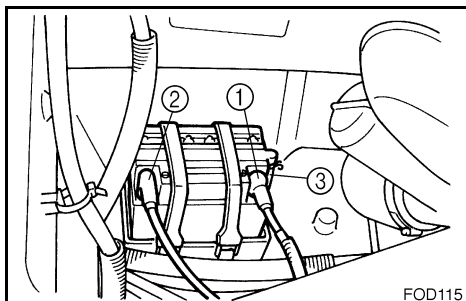
**To connect the battery terminals:**

1. Make sure that the connections are correct when you insert the battery in the watercraft.
2. Make sure that the breather hose is properly connected and that it is not damaged or obstructed.
3. Make sure that the battery is securely held in place.

- ① Positive (+): Red lead
- ② Negative (-): Black lead
- ③ Breather hose



EJU01109

Adjusting the carburetor

The carburetor is a vital part of the engine and requires very sophisticated adjustment. Most adjusting should be left to a Yamaha dealer who has the professional knowledge and experience to perform it. However, the operator may adjust the trolling speed as part of the usual maintenance routine.

CAUTION:

The carburetor was set at the Yamaha factory after many tests. If the settings are disturbed by someone who does not have the necessary technical knowledge, poor engine performance and damage may result.

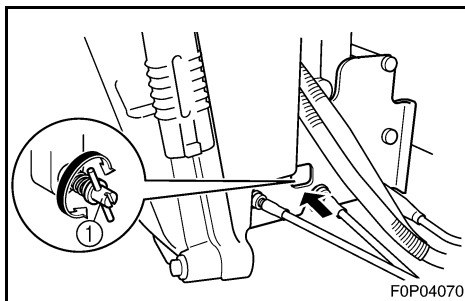

EJU01262

Adjusting the trolling speed

1. Put the watercraft in the water.
2. Start the engine and warm it up for 1 or 2 minutes. Using a diagnostic tachometer or, if necessary, the tachometer in the multifunction meter, adjust the engine speed to specification.
3. Turn the throttle stop screw ① clockwise to increase engine speed if necessary. Turn it counterclockwise to decrease engine speed if necessary.

Trolling speed: 1,250–1,350 r/min

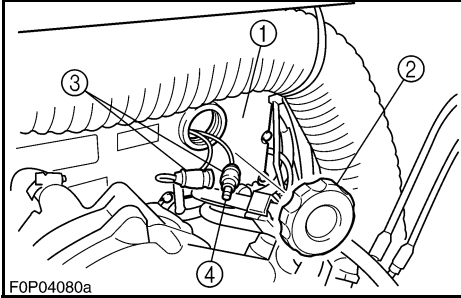

EJU01263

Replacing the fuse

The fuse is in the electrical box ①.

To replace the fuse:

1. Remove the cap ②, pull out the red lead, and bring the fuse holder ③ out of the electrical box.
2. Open the fuse holder and replace the fuse ④ with one of the correct amperage.

Fuse amperage: 10 A

⚠WARNING

Do not use fuses of higher amperage than those recommended. Substitution of a fuse of improper rating can cause extensive electrical system damage and possible fire.

EJU01112

Bleeding the oil injection pump

If the oil tank becomes completely empty, or any hose connected to the oil pump has been disconnected, the oil pump must be bled to ensure proper oil flow.

If bleeding of the oil pump is necessary, have a Yamaha dealer bleed it.



Specifications

ITEM	MODEL	Unit	XLT800
WATERCRAFT CAPACITY			
Maximum people on board		Number of people	3
Maximum load capacity		kg (lb)	240 (530)
DIMENSIONS			
Length		mm (in)	3,160 (125)
Width		mm (in)	1,220 (48)
Height		mm (in)	1,130 (45)
Dry weight		kg (lb)	322 (710)
PERFORMANCE			
Maximum output		kW (PS) @ r/min	88.2 (120)@ 7,000
Maximum fuel consumption		L/h (US gal/h, Imp gal/h)	49 (12.9, 10.8)
Cruising range at full throttle		hr.	1.4
Trolling speed		r/min	1,250–1,350
ENGINE			
Engine type			2-stroke
Number of cylinders			2
Engine displacement		cm ³ (cu in)	784 (47.84)
Bore & stroke		mm (in)	80.0 × 78.0 (3.15 × 3.07)
Compression ratio			6.6:1
Lubrication system			Variable oil injection
Cooling system			Water cooled
Starting system			Electric starter
Ignition system			Digital CDI
Spark plug			BR8ES (NGK)
Spark plug gap		mm (in)	0.7–0.8 (0.028–0.031)
Battery capacity		V-AH	12-19
Charging system			Flywheel magneto
DRIVE UNIT			
Propulsion system			Jet pump
Jet pump type			Axial flow, single stage
Impeller rotation			Counterclockwise (viewed from rear)
Transmission			Direct drive from engine
Jet thrust nozzle horizontal angle		Degree	24 + 24
Jet thrust nozzle trim angle		Degree	-7, -2, 3, 8, 13
FUEL AND OIL			
Recommended fuel			Regular unleaded gasoline
Minimum octane rating		PON RON	86 90
Recommended engine oil			YAMALUBE 2-W, or an equivalent NMMA-certified TC-W3 marine oil
Fuel tank capacity			
Total		L (US gal, Imp gal)	70 (18.5, 15.5)
Reserve		L (US gal, Imp gal)	12 (3.2, 2.7)
Oil tank capacity		L (US gal, Imp gal)	5.5 (1.5, 1.3)



-MEMO-

EJU01115

TROUBLESHOOTING AND EMERGENCY PROCEDURES

Troubleshooting	5-1
Troubleshooting chart	5-1
Emergency procedures	5-4
Cleaning the jet intake and impeller	5-4
Jumping the battery	5-5
Towing the watercraft	5-7
Submerged watercraft	5-8





EJU01116

Troubleshooting

If you have any trouble with your watercraft, use this section to check for the possible cause.

If you cannot find the cause, or if the procedure for replacement or repair is not described in this Owner's/Operator's Manual, have a Yamaha dealer perform the necessary service.

EJU01371

Troubleshooting chart

TROUBLE	POSSIBLE CAUSE		REMEDY	PAGE
Engine does not start	Starter motor does not turn over			
	Multifunction meter	"LOCK" mode selected	Select "START" mode	2-20
	Engine shut-off switch	Clip not in place	Install clip	2-10
	Fuse	Burned out	Replace the fuse and check wiring	4-23
	Battery	Run down	Recharge	4-20
		Poor terminal connections	Tighten as required	4-20
		Terminal corroded	Clean	4-5
	Starter motor	Faulty	Have serviced by Yamaha dealer	—
	Starter motor turns over			
	Fuel cock	Turned to "OFF"	Turn the fuel cock to "ON"	2-9
	Fuel	Empty	Refill as soon as possible	3-3
		Stale or contaminated	Have serviced by Yamaha dealer	4-10
	Fuel tank	Water or dirt present	Have serviced by Yamaha dealer	4-11
	Spark plug	Fouled or defective	Clean or replace	4-15
	Spark plug cap	Not connected or loose	Connect properly	4-15
	Crankcase	Filled with water	Crank engine with plug out until clean	5-8
Fuel filter	Clogged or water pooled	Have serviced by Yamaha dealer	4-11	
Choke	Knob moves back on its own	Tighten the choke knob adjusting nut	4-19	



TROUBLE	POSSIBLE CAUSE		REMEDY	PAGE
Engine runs irregularly or stalls	Fuel	Empty	Refill as soon as possible	3-3
		Stale or contaminated	Have serviced by Yamaha dealer	4-10
	Choke	Knob pulled	Push fully in	2-10
	Fuel filter	Clogged or water pooled	Have serviced by Yamaha dealer	4-11
	Fuel tank	Water or dirt present	Have serviced by Yamaha dealer	4-11
	Spark plug	Fouled or defective	Replace	4-15
		Incorrect heat range	Replace	4-15
		Gap incorrect	Adjust	4-15
	Spark plug cap	Loose	Connect properly	4-15
		Cracked, torn, or damaged	Replace	—
	Electrical wiring	Loose connection	Tighten or connect properly	—
	Carburetor	Incorrect idle adjustment	Adjust idle	4-22
		Clogged	Have serviced by Yamaha dealer	—
Warning light or indicator blinks	Fuel level	Empty	Refill as soon as possible	3-3
	Engine oil level	Empty	Refill immediately	3-4
		Oil filter clogged	Clean	4-12
	Engine overheated	Jet intake clogged	Clean	5-4
	Low battery voltage	Battery voltage low	Charge	4-20
		Battery terminal connected wrong	Connect properly	4-20



TROUBLE	POSSIBLE CAUSE		REMEDY	PAGE
Watercraft slow or loses power	Cavitation	Jet intake clogged	Clean	5-4
		Impeller damaged or worn	Have serviced by Yamaha dealer	—
	Engine over-heated	Jet intake clogged	Clean	5-4
	Fuel filter	Clogged	Have serviced by Yamaha dealer	4-11
	Spark plug	Fouled or defective	Replace	4-15
		Incorrect heat range	Replace	4-15
		Gap incorrect	Adjust	4-15
	Spark plug caps	Loose	Connect properly	4-15
	Electrical wiring	Loose connection	Tighten or connect properly	—
	Fuel	Stale or contaminated	Have serviced by Yamaha dealer	4-10
Bilge	Water in bilge	Drain	3-7	

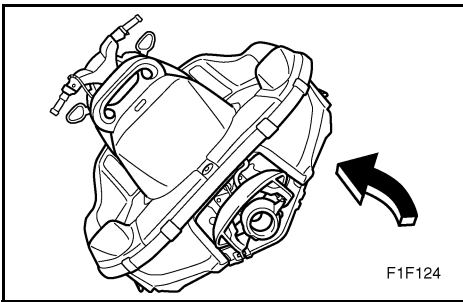
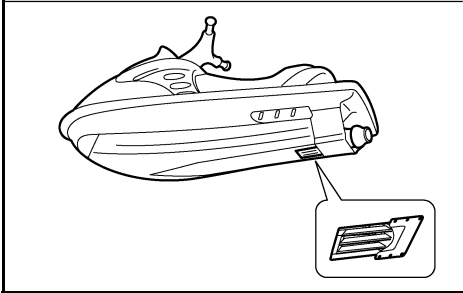
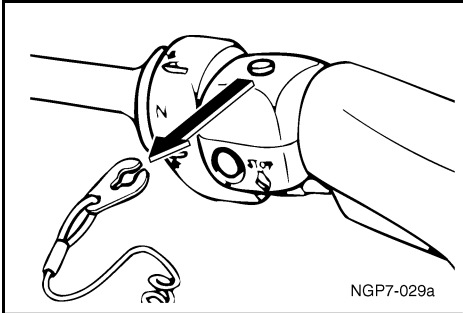

EJU01118

Emergency procedures

EJU01119

Cleaning the jet intake and impeller

If weeds or debris get caught in the intake or impeller, cavitation can occur, causing jet thrust to decrease even though engine speed rises. If this condition is allowed to continue, the engine will overheat and may seize. If there is any sign that the jet intake or impeller is clogged with weeds or debris, beach the watercraft and check the intake and impeller. Always stop the engine before beaching the watercraft.

⚠WARNING

Before attempting to remove weeds or debris from the jet intake or impeller areas, shut the engine off and remove the clip from the engine shut-off switch. Severe injury or death could result from contact with the rotating parts of the jet pump.

1. Turn the watercraft on its side as shown.

CAUTION:

- Place a suitable clean cloth or carpeting underneath the watercraft to protect it from abrasions and scratches.
- Always turn the watercraft over onto its port (left) side.
- When turning the watercraft on its side, support the bow so the handlebars cannot be bent or damaged.



2. Remove any weeds or debris from around the drive shaft, impeller, pump housing, and jet thrust nozzle.
If debris is difficult to remove, consult your Yamaha dealer.

CAUTION:

Always avoid operating your watercraft in areas where weed growth is thick. If traveling in weeded areas is unavoidable, operate the engine alternately at partial throttle and full throttle. Weeds tend to accumulate more at a steady speed and at trolling speed. If weeds clog the intake or impeller area and cause cavitation, follow the cleaning procedure above.

EJU01120

Jumping the battery

If the watercraft battery has run down, the engine can be started using a 12-volt battery and jumper cables.

⚠WARNING

Battery electrolyte is poisonous and dangerous, causing severe burns, etc. Electrolyte contains sulfuric acid. Avoid contact with skin, eyes or clothing.

Antidotes

External: Flush with water.

Internal: Drink large quantities of water or milk. Follow with milk of magnesia, beaten egg or vegetable oil. Call physician immediately.

Eyes: Flush with water for 15 minutes and get prompt medical attention.

Batteries give off explosive gases. Keep sparks, flame, cigarettes, etc. well away. If using or charging the battery in an enclosed area, make sure that it is well ventilated. Always shield your eyes when working near batteries.

KEEP OUT OF THE REACH OF CHILDREN.

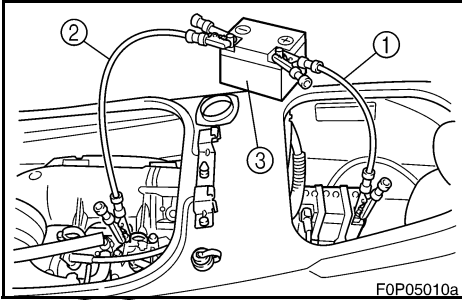

EJU01121

Connecting the jumper cables

1. Connect the positive (+) jumper cable ① to the positive (+) terminals of both batteries.
2. Connect one end of the negative (-) jumper cable ② to the negative (-) terminal of the booster battery ③.
3. Connect the other end of the negative (-) cable to an unpainted bolt on the cylinder head.

CAUTION: _____

Do not connect the end of the jumper cable to the negative (-) terminal on the watercraft battery! Be sure all connections are secure and correct before attempting to start the engine. Any wrong connection may damage the electrical system.

4. Start the engine, and then disconnect the cables by reversing the steps above.

CAUTION: _____

- Never push the start switch while the engine is running.
- Do not operate the start switch for more than 5 seconds, otherwise the battery will be discharged and the engine will not start. Also, the starter motor may be damaged. If the engine does not start in 5 seconds, release the start switch, wait 15 seconds, and try again.



EJU01122

Towing the watercraft

If the watercraft becomes inoperative in the water, it can be towed to shore.

If the watercraft must be towed in an emergency using a tow line, the operator should ride the watercraft, holding onto the handlebars.

CAUTION:

- Tow the watercraft slowly; water may enter the air intake and flood the engine compartment if the watercraft is towed too fast.
- Tow the watercraft using the bow eye ① only.
- The bow must be kept up out of the water during towing to prevent water from entering the engine compartment.

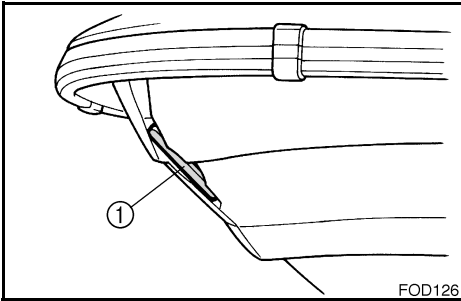

WARNING

- The watercraft should only be towed in an emergency.
- The tow line should be long enough so that the watercraft will not collide with the towing boat when slowing down. A good rule of thumb is a tow line which is three times the combined length of the towing boat and the watercraft. A shorter length of rope can be used if the watercraft is towed very slowly.
- The operator of the towing boat must keep speed to a minimum and avoid traffic or obstacles which could be a hazard to the rider on the watercraft.



EJU01171

Submerged watercraft

If the watercraft is submerged or flooded with water, follow the procedure below and consult a Yamaha dealer as soon as possible. Failure to do so may result in serious engine damage!

1. Beach the watercraft and remove the stern drain plugs to drain the water from the engine compartment.
2. Turn the fuel cock knob to "OFF."
3. Remove the spark plugs and dry them with a cloth.
4. Without reinstalling the spark plugs, crank the engine until all the water in the cylinders has been drained.
5. Install the stern drain plugs and the spark plugs.
6. Turn the fuel cock to "ON."
7. Launch the watercraft into the water, and then run the engine for at least 10 minutes. If the engine will not start, repeat steps above.
8. Turn the engine off. Turn the fuel cock to "OFF."
9. Remove the silencer cap and spray a rust inhibitor such as Yamaha Stor-Rite Engine Fogging Oil into the carburetor while cranking the engine.
10. Have the watercraft inspected by a Yamaha dealer as soon as possible.



-MEMO-

EJU01124

APPENDIX

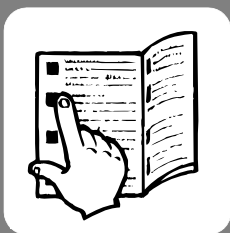

Limited warranty..... 6-1

**YAMAHA EXTENDED SERVICE
(Y.E.S.)** 6-3

Index 6-4



Limited warranty

YAMAHA MOTOR CORPORATION, U.S.A. WATERCRAFT LIMITED WARRANTY

Yamaha Motor Corporation is proud of its heritage and reputation for producing products with high standards of quality and workmanship. Product excellence provides the cornerstone for our commitment to customer satisfaction. The Yamaha Watercraft Limited Warranty is your assurance of this commitment.

This warranty provides you with protection against the expense of repairs for your watercraft that are required as a result of defects in materials or workmanship. When maintained and utilized in the prescribed manner, you can count on your Yamaha watercraft to provide reliable service.

This warranty provides you with specific coverage and notes your responsibilities in maintaining and operating your watercraft. Please take the time to read and become familiar with this warranty.

PERIOD OF WARRANTY. Any new Yamaha watercraft purchased for pleasure use from an authorized Yamaha dealer in the United States, will be warranted against defects in material or workmanship for a period of one (1) year from date of purchase, subject to exclusions noted herein. Any Yamaha Watercraft purchased and utilized for commercial applications will be warranted for a period of ninety [90] days from the date of purchase, subject to exclusions noted herein. Replacement parts used in warranty repairs will be warranted for the balance of the applicable warranty period.

The warranty described here applies to watercrafts purchased and registered for use in the United States only. For warranty provisions outside the United States, contact the particular country's local Yamaha distributor.

OBTAINING REPAIRS UNDER WARRANTY. During the period of warranty, any authorized Yamaha dealer will, free of charge, repair or replace, at Yamaha's option, any parts adjudged defective by Yamaha due to faulty workmanship or material from the factory. All parts replaced under warranty will become the property of Yamaha Motor Corporation, U.S.A.

CUSTOMER'S RESPONSIBILITY. Under the terms of this warranty, the customer will be responsible for ensuring that the watercraft is properly operated, maintained, and stored as specified in the applicable Owner's/Operator's Manual.

The owner of the watercraft shall give notice to an authorized Yamaha dealer of any and all apparent defects within ten [10] days of discovery and make the watercraft available at that time for inspection and repairs at the dealer's place of business.

GENERAL EXCLUSIONS FROM WARRANTY. This warranty will not cover the repair of damage if the damage is a result of abuse or neglect of the product. Examples of abuse and neglect include, but are not limited to:

1. Racing or competition use, modification of original parts abnormal strain.
2. Lack of proper maintenance and off season storage as described in the Owner's/Operator's Manual, installation of parts or accessories that are not equivalent in design and quality to genuine Yamaha parts.
3. Use of lubricants, oils, and fuel/oil mixtures that are not suitable for watercraft motor use.
4. Damage as a result of accidents, collisions, contact with foreign materials, or submersion.
5. Growth of marine organisms on motor or hull surfaces.
6. Normal deterioration.
7. Gel coat stress cracks.

SPECIFIC PARTS EXCLUDED FROM WARRANTY.

Parts replaced due to normal wear or routine maintenance such as oil, spark plugs, fuel filters, impeller and liner, and anodes are not covered by warranty. Charges for transporting the watercraft to and from an authorized Yamaha dealer are excluded from warranty coverage.

TRANSFER OF WARRANTY. Transfer of the warranty from the original purchaser to any subsequent purchaser is possible by having the watercraft inspected by an authorized Yamaha dealer and requesting the dealer to submit a change of registration to Yamaha Motor Corporation, U.S.A. within ten [10] days of the transfer.

YAMAHA MOTOR CORPORATION, U.S.A. MAKES NO OTHER WARRANTY OF ANY KIND, EXPRESSED OR IMPLIED. ALL IMPLIED WARRANTIES OF MERCHANTABILITY AND FITNESS FOR A PARTICULAR PURPOSE WHICH EXCEED THE OBLIGATIONS AND TIME LIMITS STATED IN THIS WARRANTY ARE HEREBY DISCLAIMED BY YAMAHA MOTOR CORPORATION, U.S.A. AND EXCLUDED FROM THIS WARRANTY.

SOME STATES DO NOT ALLOW LIMITATIONS ON HOW LONG AN IMPLIED WARRANTY LASTS. SO THE ABOVE LIMITATION MAY NOT APPLY TO YOU. ALSO EXCLUDED FROM THIS WARRANTY ARE ANY INCIDENTAL OR CONSEQUENTIAL DAMAGES INCLUDING LOSS OF USE. SOME STATES DO NOT ALLOW THE EXCLUSION OR LIMITATION OF INCIDENTAL OR CONSEQUENTIAL DAMAGES, SO THE ABOVE EXCLUSION MAY NOT APPLY TO YOU.



THIS WARRANTY GIVES YOU SPECIFIC LEGAL RIGHTS, AND YOU MAY ALSO HAVE OTHER RIGHTS WHICH VARY FROM STATE TO STATE.

**YAMAHA MOTOR CORPORATION, U.S.A.
Post Office Box 6555
Cypress, California 90630**

WARRANTY QUESTIONS AND ANSWERS

Q. What costs are my responsibility during the warranty period?

A. The customer's responsibility includes all costs of normal maintenance services, non-warranty repairs, accident and collision damages.

Q. What are some examples of "abnormal" strain, neglect, or abuse?

A. These terms are general and overlap each other in areas. Specific examples include:

Running the watercraft out of oil, operating the machine with a broken or damaged part which causes another part to fail, and so on. If you have any specific questions on operation or maintenance, please contact your Yamaha dealer for advice.

Q. Does the warranty cover incidental costs such as transportation due to a failure?

A. No. The warranty is limited to repair of the watercraft itself.

Q. May I perform any or all of the recommended maintenance shown in the Owner's/Operator's Manual instead of having the dealer do them?

A. Yes, if you are a qualified mechanic and follow the procedures specified in the Owner's/Operator's and Service Manual. We do recommend, however, that items requiring special or equipment be done by a Yamaha dealer.

Q. Will the warranty be void or cancelled if I do not operate or maintain my new watercraft exactly as specified in the Owner's/Operator's Manual?

A. No. The warranty on a new watercraft cannot be "voided" or "cancelled". **However, if a particular failure is caused by operation or maintenance other than as shown in the Owner's/Operator's Manual, that failure may not be covered under warranty.**

Q. What responsibility does my dealer have under this warranty?

A. Each Yamaha dealer is expected to:

1. Completely set up each new watercraft before sale.
2. Explain the operation, maintenance, and warranty requirements to your satisfaction at the time of sale, and upon your request at any later date. In addition, each Yamaha dealer is held responsible for his setup, service and warranty repair work.

Q. Is the warranty transferable to second owners?

A. Yes. The remainder of the existing warranty can be transferred upon request. The unit has to be inspected and re-registered by an authorized Yamaha dealer for the policy to remain effective.

CUSTOMER SERVICE

If your watercraft requires warranty service, you must take it to any authorized Yamaha dealer within the continental United States. Be sure to bring your warranty registration card or other valid proof of the original date of purchase. If a question or problem arises regarding warranty, first contact the owner of the dealership. Since all warranty matters are handled at the dealer level, this person is in the best position to help you. If you are still not satisfied and require additional assistance, please write:

YAMAHA MOTOR CORPORATION U.S.A.
CUSTOMER RELATIONS DEPARTMENT
P.O. Box 6555
Cypress, California 90630

CHANGE OF ADDRESS

The federal government requires each manufacturer to maintain a complete, up-to-date list of all first purchasers against the possibility of a safety-related defect and recall. This list is compiled from the purchase registrations sent to Yamaha Motor Corporation, U.S.A. by the selling dealer at the time of your purchase.

If you should move after you have purchased your new watercraft, please advise us of your new address by sending a postcard listing your Yamaha model name, engine number, dealer number [or dealer's name] as it is shown on your warranty card, your name and new mailing address.

Mail to:

YAMAHA MOTOR CORPORATION, U.S.A.
P.O. Box 6555
Cypress, California 90630
Attention: Warranty Department

This will ensure that Yamaha Motor Corporation, U.S.A. has an up-to-date registration record in accordance with federal law.



EJU01201

YAMAHA EXTENDED SERVICE (Y.E.S.)

Keep your Yamaha protected even after your warranty expires with genuine Yamaha Extended Service (Y.E.S.).

- Y.E.S. is designed and administered by Yamaha Motor Corporation to provide maximum owner satisfaction. You get uninterrupted factory-backed coverage for extra peace of mind.
- Y.E.S. is flexible. You choose the plan that is right for you: 12 months, 24 months, or 36 months beyond your warranty period.
- Y.E.S. is designed and administered by the same Yamaha people who handle your warranty — and it shows in the comprehensive coverage benefits. There are no mileage limitations. Coverage is not limited to “moving parts” or the “drive train” like many other plans. And Y.E.S. covers manufacturing defects just like the warranty. See the sample contract at your Yamaha dealer to see how comforting uninterrupted factory-backed protection can be.
- You do not have to pay anything for covered repairs. There is no deductible to pay, and repairs are not “pro-rated.” You do not have any “out-of-pocket” expenses for covered repairs.

- In addition, Travel and Recreation Interruption Protection (TRIP) is included at no extra cost. TRIP gives you up to \$150 reimbursement per occurrence for any reasonable expenses you incur because your Yamaha needs covered service: replacement vehicle rental, emergency towing, phone calls, even food and lodging when you are away from home. This superb coverage goes into effect when you purchase Y.E.S., so it applies to any warranty repairs as well as covered repairs during your entire Y.E.S. plan period.

- Y.E.S. coverage is honored at any authorized Yamaha dealer nationwide.

- Y.E.S. coverage is transferable to a new owner if you sell or trade-in. That can make your Yamaha much more valuable!

This excellent Y.E.S. plan coverage is only available to Yamaha owners like you, and only while your Yamaha is still within the Yamaha Limited Warranty period. So visit your authorized Yamaha dealer to get all the facts. He can show you how easy it is to protect your investment with Yamaha Extended Service.

We urge you to act now. You will get the excellent benefits of TRIP coverage right away, and you will rest easy knowing you will have strong factory-backed protection even after your Yamaha Limited Warranty expires. You can also save money: Y.E.S. costs less within the first 90 days after you buy your Yamaha. See your dealer today!

A special note:

If visiting your dealer is not convenient, contact Yamaha with your Primary ID number (your engine number). We will be happy to help you get the Y.E.S. coverage you need.

Yamaha Service Marketing
P.O. Box 6555
Cypress, CA 90630
(714) 761-7631



YAMAHA EXTENDED SERVICE



Index

2-stroke engine oil 3-2

A

Adjusting the carburetor 4-22

Adjusting the choke cable 4-19

Adjusting the trolling speed 4-22

Approval label of Emission control
certificate 1-2

B

Battery 3-8, 4-5

Battery warning indicator 2-26

Beaching the watercraft 3-31

Bilge 3-7

Bleeding the oil injection pump 4-23

Boarding alone 3-24

Boarding and starting in deep water 3-24

Boarding with passengers 3-25

Bow down 2-16

Bow up 2-16

C

Capsized watercraft 3-26

Caution labels 1-6

Choke knob 2-10

Cleaning and adjusting the spark
plugs 4-15

Cleaning the jet intake and impeller 5-4

Cleaning the watercraft 4-6

Clock 2-23

Connecting the jumper cables 5-6

Cooling water pilot outlet 2-12, 3-13

Crossing 1-17

Cruising limitations 1-9

D

Docking the watercraft 3-31

E

Emergency procedures 5-4

Emission control information 1-2

Engine break-in 3-14

Engine compartment 3-6

Engine oil meter 2-23

Engine overheat warning indicator 2-26

Engine overheat warning system 2-17

Engine serial number 1-1

Engine shut-off cord (lanyard) 3-12

Engine shut-off switch 2-10

Engine stop switch 2-10

Enjoy your watercraft responsibly 1-21

F

Filling the fuel tank 3-3

Filling the oil tank 3-4

Fire extinguisher 3-9

Fishing vessel right-of-way 1-18

Flushing the cooling system 4-1

Front seat 2-6

Front storage compartment 2-27

Fuel and oil 3-1

Fuel and oil systems 3-6

Fuel cock knob 2-9

Fuel filter 4-11

Fuel meter 2-22

Fuel system 4-4

Fuel tank 4-11

Fuel tank filler cap 2-8

Fuel warning indicator 2-25

G

Gasohol 3-2

Gasoline 3-1

Getting to know your watercraft 3-20

Give-way vessel 1-16

Glove compartment 2-29

H

Handgrip 2-16

Hazard information 1-13

Hood 2-7

Hour meter 2-24

Hull Identification Number (HIN) 1-1

I

Identification numbers 1-1

Important labels 1-3

Inspecting and adjusting the throttle
cable 4-13

Inspecting the battery 4-20

Inspecting the fuel system 4-10



Inspecting the oil injection system.....	4-12	P	PADLOC initial setting.....	2-19
Inspecting the QSTS mechanism.....	4-14		PADLOC (Programmable digital	
Inspecting the shift cable.....	4-13		locking ignition)	2-19
Inspecting the steering cable	4-13		Periodic maintenance chart.....	4-9
J			Post-operation checks.....	3-33
Jet unit.....	3-12		Pre-operation check list.....	3-5
Jumping the battery.....	5-5		Pre-operation check points	3-6
L			Pre-operation checks	3-5
Label location	1-3		Primary Identification (PRI-ID) number ...	1-1
Launching the watercraft.....	3-16		Q	
Learning to operate your watercraft	3-20		Quick Shift Trim System (QSTS)	
Leaving the watercraft.....	3-19		selector.....	2-15
Limitations on who may operate the			R	
watercraft	1-8		Reading buoys and other markers	1-18
Limited warranty.....	6-1		Rear seat.....	2-5
Location of main components	2-1		Recommended equipment	1-12
Lubrication.....	4-3		Replacing the fuse	4-23
Lubrication points	4-16		Reverse on waterways.....	3-32
M			Riding watercraft with passengers	3-21
Maintenance and adjustments	4-7		Rough water operation	3-32
Manufactured date label.....	1-2		Rules of the Road	1-16
Meeting	1-17		Rules when encountering vessels.....	1-17
Multifunction meter.....	2-18, 3-13		S	
N			Safety information	1-8
Narrow channels and bends	1-18		Sailing vessel right-of-way	1-18
O			Seat storage compartment.....	2-29
Oil filter.....	4-12		Selecting “PADLOC” mode	2-20
Oil tank.....	4-12		Shift lever	2-14
Oil tank filler cap.....	2-8		Shift lever and reverse gate	3-11
Oil warning indicator.....	2-26		Specifications	4-24
Operating your watercraft.....	3-20		Speedometer.....	2-22
Operation	3-14		Stand-on vessel	1-16
Operation of controls and other			Starting and boarding in shallow	
functions.....	2-5		water	3-23
Operation requirements	1-10		Starting from a dock.....	3-23
Other labels.....	1-7		Starting the engine	3-16
Other sources.....	1-20		Starting the watercraft	3-22
Other special situations.....	1-18		Start switch.....	2-11
Overtaking.....	1-18		Steering and sailing rules.....	1-16
Owner’s/Operator’s Manual and			Steering system	2-12, 3-10
tool kit.....	4-8			



Stopping the engine 3-19
Stopping the watercraft 3-30
Storage 4-1
Storage compartments 2-27
Submerged watercraft 5-8
Switches 3-13

T

Tachometer 2-21
Throttle 3-10
Throttle lever 2-11
Tilt lever 2-13
To get more boating safety
information 1-20
Towing the watercraft 5-7
Transporting 3-35
Tripmeter 2-25
Trip timer 2-24
Troubleshooting 5-1
Troubleshooting chart 5-1
Turning the watercraft 3-28

U

United States Coast Guard 1-20

W

Warning labels 1-4
Watercraft characteristics 1-13
Watercraft Education and Training 1-20
Water separator 3-7
Water-skiing 1-14

Y

YAMAHA EXTENDED SERVICE
(Y.E.S.) 6-3



Printed in USA
September 2001—1.1 × 1 CR
F1F-F8199-10
(XA800A-A)
(E)

Printed on recycled paper