



**! READ THIS MANUAL CAREFULLY!**  
It contains important safety information.

**OWNER'S MANUAL**

***RAHINDO***

**FUEL INJECTION**

***700 FI***

***YXR70FX***

LIT-11626-21-58

5B4-F8199-10

**⚠ WARNING**

**The engine exhaust from this product contains chemicals known to the State of California to cause cancer, birth defects or other reproductive harm.**

YAMAHA

LIT-CALIF-65-01

## INTRODUCTION

Congratulations on your purchase of the Yamaha YXR70FX. It represents the result of many years of Yamaha experience in the production of fine sporting, touring, and pace-setting racing vehicles. With the purchase of this Yamaha, you can now appreciate the high degree of craftsmanship and reliability that have made Yamaha a leader in these fields.

This manual will provide you with a good basic understanding of the features and operation of this vehicle. It also includes basic maintenance and inspection procedures. If you have any questions regarding the operation or maintenance of your vehicle, please consult a Yamaha dealer.

### **WARNING**

---

**Please read this manual carefully before operating this vehicle. Do not attempt to operate this vehicle until you have attained adequate knowledge of its controls and operating features. Regular inspections and careful maintenance, along with good operating techniques, will help ensure that you safely enjoy the capabilities and reliability of this vehicle.**

---

## IMPORTANT MANUAL INFORMATION

FAILURE TO FOLLOW THE WARNINGS CONTAINED IN THIS MANUAL CAN RESULT IN SERIOUS INJURY OR DEATH.

Particularly important information is distinguished in this manual by the following notations:



**This is the safety alert symbol. It is used to alert you to potential personal injury hazards. Obey all safety messages that follow this symbol to avoid possible injury or death.**



**A WARNING indicates a hazardous situation which, if not avoided, could result in death or serious injury.**

### ***NOTICE***

**A NOTICE indicates special precautions that must be taken to avoid damage to the vehicle or other property.**

### **TIP**

**A TIP provides key information to make procedures easier or clearer.**

\*Product and specifications are subject to change without notice.

## **IMPORTANT NOTE ABOUT USE**

- **This vehicle is designed and manufactured for off-road use only. Use on public streets, roads, or highways is not only illegal in most areas, it also increases the risk of an accident involving other vehicles. This vehicle does not meet federal motor vehicle safety standards for on-road use.**
- **Check the laws and regulations in force before choosing where to operate this vehicle. It is illegal to operate this vehicle on public lands where vehicles its size are prohibited.**
- **This vehicle complies with almost all state off-highway noise level and spark arrester laws and regulations.**

**YXR70FX**

**OWNER'S MANUAL**

**©2007 by Yamaha Motor Corporation,  
U.S.A.**

**1st edition, August 2007**

**All rights reserved. Any reprinting or  
unauthorized use without the written  
permission of**

**Yamaha Motor Corporation,  
U.S.A. is expressly prohibited.**

**Printed in U.S.A.**

**P/N LIT-11626-21-58**

# CONTENTS

<b>1</b>	LOCATION OF THE WARNING AND SPECIFICATION LABELS.....	1-1	Glove compartment .....	4-18
<b>2</b>	SAFETY INFORMATION.....	2-1	Cup holders.....	4-18
<b>3</b>	DESCRIPTION .....	3-1	Cargo bed .....	4-19
<b>4</b>	INSTRUMENT AND CONTROL FUNCTIONS .....	4-1	Front and rear shock absorber adjustment .....	4-21
	Main switch.....	4-1	Trailer hitch bracket and receiver .....	4-23
	Indicator and warning lights .....	4-2	Auxiliary DC jack.....	4-23
	Multi-function meter unit.....	4-5	<b>5</b>	FOR YOUR SAFETY –
	Switches .....	4-11	PRE-OPERATION CHECKS .....	5-1
	Accelerator pedal .....	4-13	Front and rear brakes .....	5-3
	Brake pedal .....	4-13	Fuel .....	5-4
	Parking brake lever .....	4-14	Engine oil .....	5-6
	Drive select lever .....	4-15	Coolant.....	5-7
	Fuel tank cap.....	4-15	Final gear oil .....	5-7
	Doors .....	4-16	Differential gear oil .....	5-7
	Seats .....	4-16	Accelerator pedal .....	5-8
	Seat belts.....	4-17	Seat belts .....	5-8
			Steering.....	5-8
			Fittings and fasteners .....	5-8
			Lights.....	5-9
			Switches.....	5-9

Control cables .....	5-9
Tires .....	5-9

## 6

OPERATION.....	6-1
Engine break-in .....	6-1
Starting the engine .....	6-2
Drive select lever operation and reverse driving.....	6-4
On-Command four-wheel-drive switch and differential gear lock switch .....	6-6
Parking .....	6-8
Loading .....	6-9

## 7

BASIC GUIDE FOR SAFE USE.....	7-1
KNOW YOUR VEHICLE.....	7-1
Driver requirements .....	7-3
Passenger requirements.....	7-4
Occupant protection system .....	7-4
Protective structure .....	7-6
Seat belts .....	7-6
Doors.....	7-9
Passenger handholds .....	7-9

Seat and hip restraints .....	7-10
Floorboard .....	7-11
Steering wheel.....	7-11

## LEARNING TO OPERATE

YOUR VEHICLE.....	7-12
Personal protective equipment.....	7-12
Practice for new Rhino users .....	7-13
Getting ready to ride .....	7-14
Turning.....	7-15
Accelerating.....	7-16
Braking.....	7-16
Engine braking.....	7-16
Leaving the vehicle.....	7-17
Parking on a flat area .....	7-17
Parking on a slope.....	7-17
Loading.....	7-18
Operation on different surfaces and terrains.....	7-18
Hills .....	7-19
Uphill.....	7-20
Downhill .....	7-21
Rough terrain.....	7-22
Pavement .....	7-22

Water .....	7-22
Loose terrain/slippery terrain.....	7-23
Brush or wooded areas .....	7-24
Encountering obstacles .....	7-24

## 8

### PERIODIC MAINTENANCE AND

ADJUSTMENT .....	8-1
Owner's manual and tool kit.....	8-2
Periodic maintenance chart for the emission control system.....	8-4
General maintenance and lubrication chart .....	8-5
Hood .....	8-7
Console .....	8-9
Engine oil and oil filter cartridge ....	8-10
Final gear oil.....	8-16
Differential gear oil.....	8-19
Coolant .....	8-21
Axle boots.....	8-23
Spark plug inspection .....	8-24
Cleaning the air filter element .....	8-26
Drive select lever box check hose .....	8-31

V-belt cooling duct check hose.....	8-32
V-belt case drain plug .....	8-32
Cleaning the spark arrester .....	8-33
Valve clearance .....	8-34
Brakes.....	8-34
Checking the front and rear brake pads .....	8-34
Checking the parking brake pads .....	8-35
Checking the brake fluid level.....	8-36
Brake fluid replacement.....	8-37
Checking the brake pedal.....	8-37
Parking brake lever free play adjustment .....	8-38
Brake light switch adjustment .....	8-39
Cable inspection and lubrication....	8-40
Brake pedal and accelerator pedal lubrication.....	8-41
Rear knuckle upper and lower pivot lubrication .....	8-41
Steering shaft lubrication .....	8-43
Wheel removal .....	8-43
Tire replacement.....	8-44



Wheel installation .....	8-45
Battery .....	8-46
Battery maintenance .....	8-47
Jump-starting .....	8-48
Fuse replacement .....	8-51
Replacing a headlight bulb .....	8-53
Headlight beam adjustment .....	8-55
Tail/brake light bulb replacement .....	8-56
Troubleshooting .....	8-58
Troubleshooting charts .....	8-59

<b>9</b> CLEANING AND STORAGE .....	9-1
A. Cleaning .....	9-1
B. Storage .....	9-2

<b>10</b> SPECIFICATIONS .....	10-1
--------------------------------	------

<b>11</b> CONSUMER INFORMATION .....	11-1
Identification number records .....	11-1
NOISE REGULATION .....	11-4
MAINTENANCE RECORD .....	11-5

YAMAHA MOTOR CORPORATION, U.S.A. SIDE × SIDE VEHICLE LIMITED WARRANTY .....	11-6
YAMAHA EXTENDED SERVICE (Y.E.S.) .....	11-7

# LOCATION OF THE WARNING AND SPECIFICATION LABELS

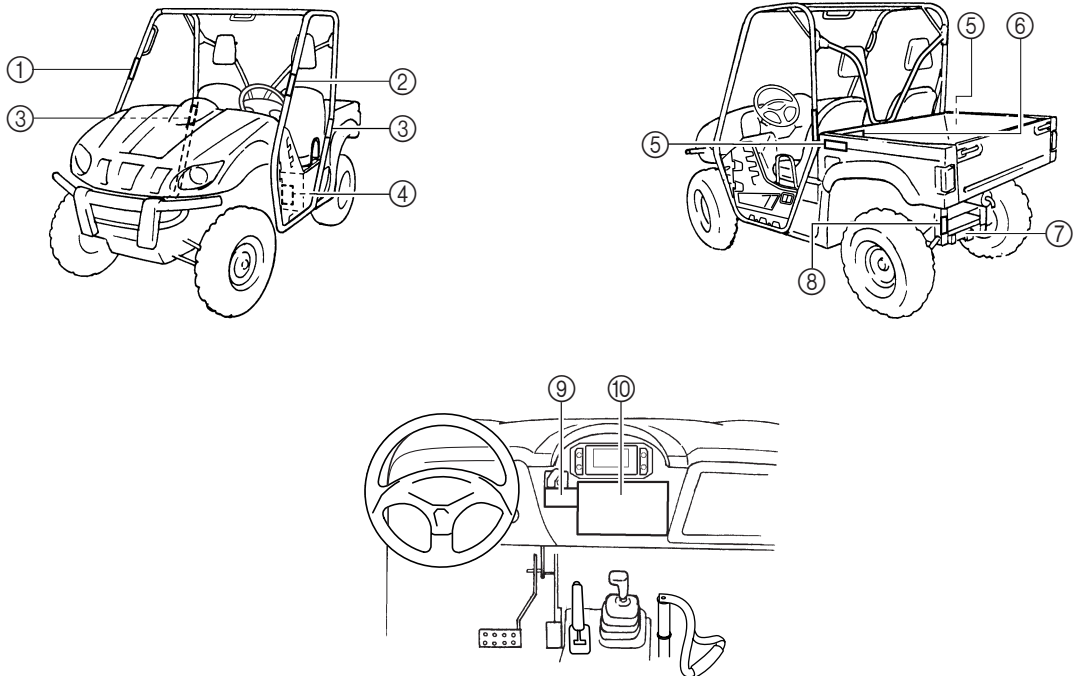

Read and understand all of the labels on your vehicle. They contain important information for safe and proper operation of your vehicle.

Never remove any labels from your vehicle. If a label becomes difficult to read or comes off, a replacement label is available from your Yamaha dealer.

①

**⚠ WARNING**



Any part of your body (arms, legs, or head) outside of the vehicle can be crushed by the cage/frame.

If you think or feel that the vehicle may tip or roll, brace your feet on the floorboards, and keep your hands on the handholds.

Do not try to stop a vehicle tipover using your arm or leg.

**YAMAHA** 5B4-K7762-00

②

**⚠ WARNING**



Any part of your body (arms, legs, or head) outside of the vehicle can be crushed by the cage/frame.

If you think or feel that the vehicle may tip or roll, brace your feet on the floorboards, and keep your hands on the steering wheel.

Do not try to stop a vehicle tipover using your arm or leg.

**YAMAHA** 5B4-K7761-00

③

**⚠ WARNING**

Do not rest hands on door or hip restraint bar. To avoid injury, keep hands completely inside the vehicle by holding the steering wheel or handholds.

YAMAHA 5B4-K8483-00

④

## **⚠ WARNING**

Improper tire pressure or overloading the Rhino may cause severe injury or death from loss of control or rollover.

**OPERATING TIRE PRESSURE:** Set with tires cold.  
**RECOMMENDED:**

FRONT: 70kPa, (.70kgf/cm<sup>2</sup>), 10psi

REAR: 98kPa, (.98kgf/cm<sup>2</sup>), 14psi

**MINIMUM:** FRONT: 63kPa, (.63kgf/cm<sup>2</sup>), 9psi

REAR: 91kPa, (.91kgf/cm<sup>2</sup>), 13psi

Never set or allow tire pressure to be below the minimum. Tire may dislodge from rim.

Gross Vehicle Weight Rating: 907 kg (2000 lb)  
maximum including vehicle, weight of operator,  
passenger, accessories, cargo, and (if applicable)  
trailer tongue weight.

YAMAHA

5B4-F1696-00

⑤

## **⚠ WARNING**

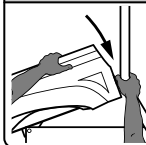

Keep hands, body, and other people away from pinch points when lowering bed. Do not hold the cage/frame while closing bed.

YAMAHA

5B4-K7764-00

⑥

## ⚠ WARNING

Improper use of cargo bed or cage/frame can result in severe injury or death from loss of control, overturn or other accidents.

- Do not carry passengers in cargo bed.
- Maximum load in cargo bed: 181 kg (400 lb).
- Load or trailer may affect handling and stability:
  - Secure cargo so that it will not shift – a loose load could change handling unexpectedly or be thrown forward and strike occupants.
  - Keep weight in the cargo bed centered side to side, and as low and as far forward as possible. Top-heavy loads increase the risk of overturn.
  - Do not tow or pull objects from any point other than the trailer hitch bracket or winch (if installed).
- When loaded with cargo or towing a trailer:
  - Reduce speed and allow more room to stop.
  - Turn gradually and go slowly.
  - Avoid hills and rough terrain.
- Read Owner's Manual before loading, towing, or pulling objects.

YAMAHA

5B4-F4897-00

⑦

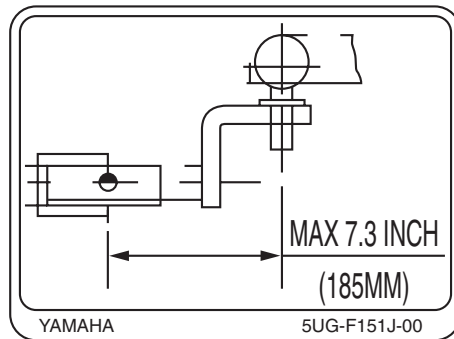

⑧

## **WARNING**

Improperly loading a trailer or pulling an object can affect handling, stability, and risk of overturn or other accidents.

- Secure load to prevent it from shifting.
- Never load more than 50 kg (110 lb) tongue weight on the towing bracket.
- Do not tow more than 550 kg (1212 lb) rolling weight (trailer plus cargo).
- Tow or pull only from hitch bracket.
- Read Owner's Manual before loading, towing, or pulling objects.

YAMAHA

5B4-F151K-00

⑨

## **Head to Toe Safety Checklist**

- |                |   |
|----------------|---|
| ✓ <b>Head</b>  | Helmet and eye protection.                                  |
| ✓ <b>Body</b>  | Seatbelt and protective clothing.                           |
| ✓ <b>Hands</b> | Inside vehicle and holding the handholds or steering wheel. |
| ✓ <b>Feet</b>  | On floorboard, ready to brace, and door closed.             |

YAMAHA

5B4-F1558-00

## ⚠ WARNING

### To reduce risk of accidents and injury or death:

#### Be Prepared

- Wear seat belt, motorcycle helmet, eye protection and protective gear.
- Keep your body completely inside the vehicle at all times. Keep both hands on the steering wheel. Be sure passenger is seated, belted, and holding onto the handholds.



#### Be Qualified and Responsible

- This vehicle is intended for use only by an operator 16 or older with a valid motor vehicle license.
- Passenger and driver must be able to place both feet flat on the floorboard while seated upright with their backs against the seat backs.
- Do not drive or ride as passenger after using drugs or alcohol.
- Do not operate on public roads.



#### Avoid Rollovers and Crushing Injuries

- Use care when turning:
  - Turning the steering wheel too far or too fast can result in a rollover or loss of control.
  - Slow down before entering a turn.
  - When making tight turns from a stop or at slow speeds, avoid sudden or hard acceleration.
  - Avoid sideways sliding, skidding, or fishtailing, and never do donuts.
- Drive straight up and down inclines, not across them. If crossing a hill is unavoidable, drive slowly and turn downhill immediately if you feel the vehicle may tip.
- Avoid paved surfaces. Turn gradually and go slowly if you must drive on pavement. This vehicle is designed for off-road use only.

#### If you think or feel the Rhino may tip or roll:

- Brace yourself by pressing your feet firmly on the floorboards and keep a firm grip on the steering wheel or handholds.
- Do not put your hands or feet outside of the vehicle for any reason.



**Abrupt maneuvers or aggressive driving have caused rollovers – even on flat, open areas.**

**Genuine Yamaha Doors and a Handhold/Strap are available for free installation or replacement.** Yamaha recommends these features to help keep occupants from sticking arms or legs out of the vehicle during a rollover.

Read the Owner's Manual

Contact your dealer or visit  
[www.yamaha-motor.com/rhino](http://www.yamaha-motor.com/rhino)

YAMAHA

5B4-F1568-01



## SAFETY INFORMATION

### **Be a responsible owner**

As the vehicle's owner, you are responsible for the safe and proper operation of your Rhino. While understanding all parts of this manual are important for vehicle ownership, be sure to read this chapter and the instructions in Chapter 7 before operating the Rhino. Also use these two chapters and the labels on the vehicle to instruct new operators and passengers. Do not allow anyone else to operate your vehicle or ride as a passenger if you are unsure that he/she is willing and able to follow these instructions.

### **Get to know your vehicle**

This off-road vehicle will handle and maneuver differently from cars, ATVs, go-carts, golf-cars and grounds-keeping vehicles. Follow these instructions to reduce your risk of an accident and to reduce the risk of serious injury or death in the event of an accident.



## Before you operate the Rhino

- Prepare yourself and your passenger:
  - This vehicle is intended for use only by an operator 16 or older with a valid motor vehicle license.



- This vehicle is designed to carry the driver and one passenger. Never carry passengers in the cargo bed.
- Both driver and passenger should wear seat belts properly.
- Both driver and passenger must be able to put both feet flat on the floorboard while seated upright with their backs against the seat backs. Passenger must be able to reach and hold the handholds within the cage/frame.
- Both driver and passenger should wear an approved motorcycle helmet that fits properly. Both driver and passenger should also wear eye protection (goggles or a face shield), gloves, over-the-ankle boots, long-sleeved shirt or jacket, and long pants.
- Do not drive or ride as passenger after using drugs or alcohol.

## **Prepare your vehicle**

Perform the pre-operation checks each time you use the vehicle to make sure it is in safe operating condition. Failure to inspect or maintain the vehicle properly increases the possibility of an accident or equipment damage. See pages 5-1–5-2 for a list of pre-operation checks.

## **Prepare your load or trailer**

Carrying loads, towing a trailer, or pulling objects can affect handling, stability, and risk of overturn or other accidents.

- Read Chapter 6 before loading, towing, or pulling objects.
- Do not overload the vehicle or trailer. Refer to label in cargo bed for cargo bed load limit. Refer to label next to hitch for tongue weight and trailer load limits.
- Keep weight in the cargo bed centered side to side, and as low and as far forward as possible.
- Secure cargo so that it will not shift – a loose load could change handling unexpectedly or be thrown forward and strike occupants.

## **While using the Rhino**

- Keep your body completely inside the vehicle at all times. Keep both hands on the steering wheel. Be sure passenger is seated, belted, and holding onto the handholds. Close doors before driving. Any part of your body (arms, legs, and head) outside the vehicle can be struck by objects your vehicle is passing or crushed by the vehicle cage/frame in a rollover accident.
- Watch for branches, brush, or other hazards that could enter the vehicle.
- Abrupt maneuvers or aggressive driving, even on flat, open areas, can cause loss of control, including rollovers. The Rhino has higher ground clearance and other features to handle rugged terrain, and, as a result, can overturn in situations where some other vehicles may not.

- Avoid rollovers:
  - Use care when turning:
    - Turning the steering wheel too far or too fast can result in a rollover.
    - Avoid sideways sliding, skidding, or fishtailing, and never do donuts.
    - Slow down before entering a turn and avoid hard braking in a turn.
    - When making tight turns from a stop or at slow speeds, avoid sudden or hard acceleration.

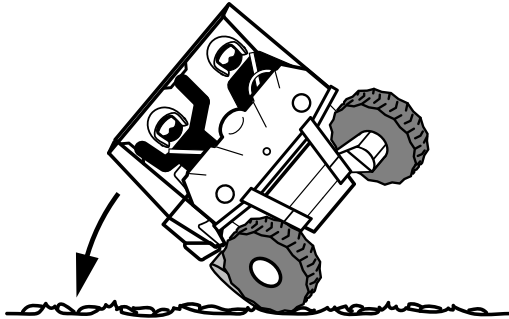

- Drive straight up and down inclines, not across them. If crossing a hill is unavoidable, drive slowly and turn downhill immediately if you feel the vehicle may tip.
- Avoid paved surfaces. Turn gradually and go slowly if you must drive on pavement. This vehicle is designed for off-road use only.
- If you think or feel that the vehicle may tip or roll, keep your body completely inside the protective structure of the vehicle:
  - Brace yourself by pressing your feet firmly on the floorboards and keep a firm grip on the steering wheel or handholds.
  - Do not put your hands or feet outside of the vehicle for any reason. Your arm or leg could be crushed.
  - Do not try to stop a vehicle tipover using your arm or leg.
- Do not operate this vehicle on any public street, road, or highway, even if dirt or gravel.
- Do not operate the vehicle in fast-flowing water or water deeper than 33 cm (13 in). If you must cross shallow, slow-moving water, choose your path carefully to avoid sharp drop-offs, large rocks, or slippery surfaces. Operating this vehicle through deep or fast-flowing water can lead to loss of control or overturn. To reduce your risk of drowning or other injuries, use care when crossing through water.

- When loaded with cargo or towing a trailer:
  - Reduce speed, operate in low gear only, and allow more room to stop.
  - Avoid hills and rough terrain. Use extreme caution when towing or carrying a load on inclines.
  - Load trailer properly and use extra care when towing or pulling.
- Do not tow or pull objects from any part of the vehicle other than the trailer hitch bracket or winch (if installed).

## **Avoid carbon monoxide poisoning**

All engine exhaust contains carbon monoxide, a deadly gas. Breathing carbon monoxide can cause headaches, dizziness, drowsiness, nausea, confusion, and eventually death.

Carbon monoxide is a colorless, odorless, tasteless gas which may be present even if you do not see or smell any engine exhaust. Deadly levels of carbon monoxide can collect rapidly and you can quickly be overcome and unable to save yourself. Also, deadly levels of carbon monoxide can linger for hours or days in enclosed or poorly-ventilated areas. If you experience any symptoms of carbon monoxide poisoning, leave the area immediately, get fresh air, and **SEEK MEDICAL TREATMENT**.

- Do not run engine indoors. Even if you try to ventilate engine exhaust with fans or open windows and doors, carbon monoxide can rapidly reach dangerous levels.
- Do not run engine in poorly ventilated or partially enclosed areas such as barns, garages, or carports.
- Do not run engine outdoors where engine exhaust can be drawn into a building through openings such as windows and doors.

## **Genuine Yamaha Accessories**

Choosing accessories for your Rhino is an important decision. Genuine Yamaha Accessories, which are available only from a Yamaha dealer, have been designed, tested, and approved by Yamaha for use on your Rhino.

Many companies with no connection to Yamaha manufacture parts and accessories or offer other modifications for Yamaha vehicles. Yamaha is not in a position to test the products that these aftermarket companies produce. Therefore, Yamaha can neither endorse nor recommend the use of accessories not sold by Yamaha or modifications not specifically recommended by Yamaha, even if sold and installed by a Yamaha dealer.

## **Aftermarket parts, accessories, and modifications**

While you may find aftermarket products similar in design and quality to genuine Yamaha Accessories, recognize that some aftermarket accessories or modifications are not suitable because of potential safety hazards to you or others. Installing aftermarket products or having other modifications performed to your Rhino that change any of the vehicle's design or operation characteristics can put you and others at greater risk of serious injury or death. You are responsible for injuries related to changes in the vehicle.



### **Aftermarket tires and rims**

The tires and rims that came with your Rhino were designed to match the performance capabilities and to provide the best combination of handling, braking, and comfort. Other tires, rims, sizes, and combinations may not be appropriate. Refer to pages 8-43–8-46 for tire specifications and more information on replacing your tires.

# DESCRIPTION

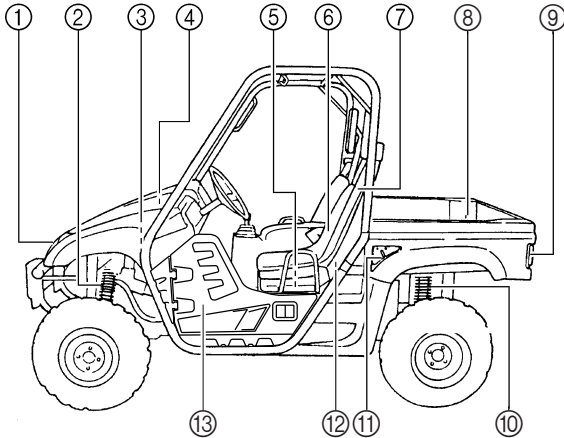

1. Headlights
2. Front shock absorber assembly
3. Brake fluid reservoir
4. Air filter element
5. V-belt case
6. Driver seat
7. Driver seat belt
8. Cargo bed
9. Tail/brake lights
10. Rear shock absorber assembly
11. Cargo bed release levers
12. Spark plug
13. Door

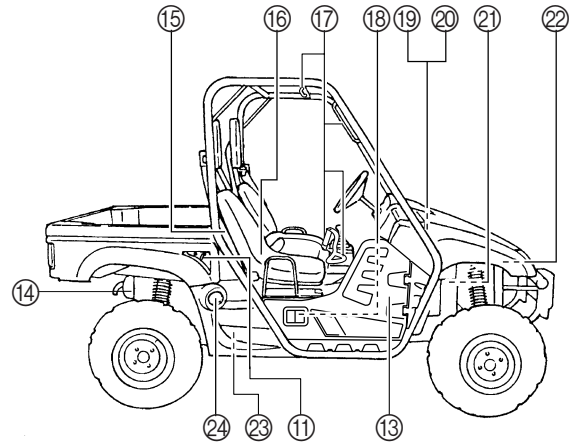

14. Spark arrester
15. Passenger seat belt
16. Passenger seat
17. Passenger handhold
18. Engine oil dipstick
19. Battery
20. Fuses
21. Coolant reservoir
22. Radiator cap
23. Oil filter cartridge
24. Fuel tank cap

The vehicle you have purchased may differ slightly from those shown in the figures of this manual.

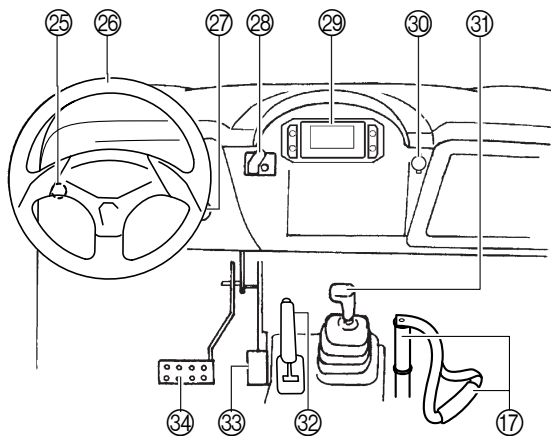

- 25. Light switch
- 26. Steering wheel
- 27. Main switch
- 28. On-Command four-wheel-drive and differential gear lock switches
- 29. Multi-function meter unit
- 30. Auxiliary DC jack
- 31. Drive select lever
- 32. Parking brake lever
- 33. Accelerator pedal
- 34. Brake pedal

# INSTRUMENT AND CONTROL FUNCTIONS

## Main switch

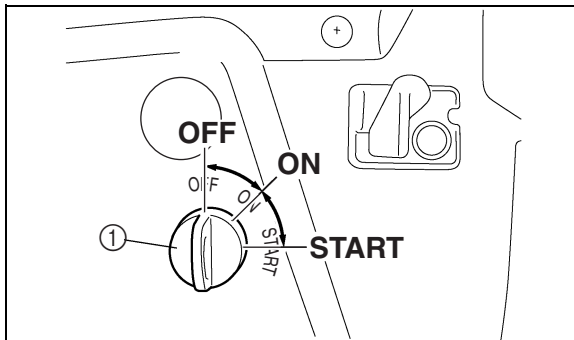

1. Main switch

Functions of the respective switch positions are as follows:

**ON:**

All electrical circuits are supplied with power, and the headlights and tail-lights come on when the light switch is on.

**OFF:**

All electrical circuits are switched off. The key can be removed in this position.

**START:**

The electric starter is engaged by turning and holding the key in this position. Release the key when the engine starts.

## Indicator and warning lights

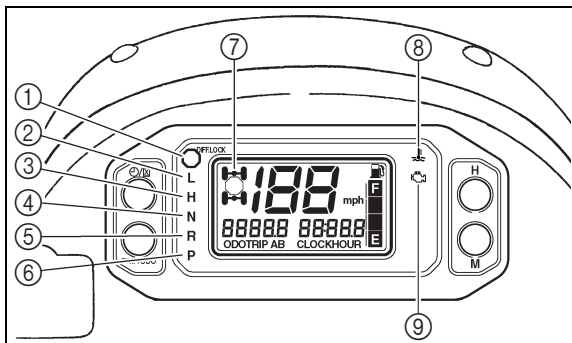

1. On-Command differential gear lock indicator light “DIFF. LOCK”
2. Low-range indicator light “L”
3. High-range indicator light “H”
4. Neutral indicator light “N”
5. Reverse indicator light “R”
6. Parking brake indicator light “P”
7. On-Command four-wheel-drive/differential gear lock indicator “”/“”
8. Coolant temperature warning light “”
9. Engine trouble warning light “”

## On-Command differential gear lock indicator light “DIFF. LOCK”

This indicator light and the On-Command differential gear lock indicator in the display come on when the On-Command differential gear lock switch is set to the “LOCK” position.

4

When the switch is set to “LOCK”, the On-Command differential gear lock indicator light will flash until the differential gear is locked.

## Low-range indicator light “L”

This indicator light comes on when the drive select lever is in the “L” position.

## High-range indicator light “H”

This indicator light comes on when the drive select lever is in the “H” position.

### Neutral indicator light “N”

This indicator light comes on when the drive select lever is in the “N” position.

### Reverse indicator light “R”

This indicator light comes on when the drive select lever is in the “R” reverse position.

### Parking brake indicator light “P”

This indicator light comes on when the parking brake is applied.

### On-Command four-wheel-drive/differential gear lock indicator “”/“”

The On-Command four-wheel-drive indicator “” comes on when the On-Command four-wheel-drive switch is set to the “4WD” position.

The On-Command differential gear lock indicator “” in the On-Command four-wheel-drive indicator also comes on when the On-Command differential gear lock switch is set to the “LOCK” position.

- Due to the synchronizing mechanism in the differential gear case, the four-wheel-drive indicator may not come until the vehicle starts moving.
- When the On-Command differential gear lock switch is set to “LOCK”, the indicator “” will flash until the differential gear is locked.

### **Coolant temperature warning light “”**

If the coolant temperature reaches a specified level, this light comes on to warn that the coolant temperature is too hot. If the light comes on during operation, stop the engine as soon as it is safe to do so and allow the engine to cool down for about 10 minutes.

(See page 8-60.)

The electrical circuit of the warning light can be checked by turning the key to “ON”. If the warning light does not come on, have a Yamaha dealer check the electrical circuit.

### ***NOTICE***

- **The engine may overheat if the vehicle is overloaded. If this happens, reduce the load to specification.**
- **After restarting, make sure that the light is out. Continuous use while the light is on may cause damage to the engine.**

### **Engine trouble warning light “”**

This warning light comes on or flashes when an electrical circuit monitoring the engine is defective. When this occurs, have a Yamaha dealer check the self-diagnosis system. (See page 4-10 for an explanation of the self-diagnosis device.)

The electrical circuit of the warning light can be checked by turning the key to “ON”. If the warning light does not come on, then go off, have a Yamaha dealer check the electrical circuit.

## Multi-function meter unit

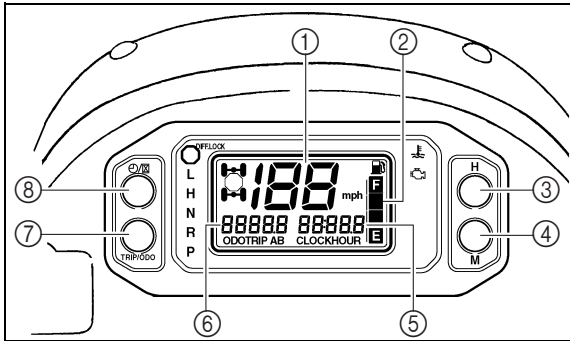

1. Speedometer
2. Fuel meter
3. "H" button
4. "M" button
5. Clock/Hour meter/Voltage display
6. Odometer/Tripmeter A/Tripmeter B
7. "TRIP/ODO" button
8. Clock/Hour button "🕒 / 🕒"

The multi-function meter unit is equipped with the following:

- a speedometer (which shows the riding speed)
- an odometer (which shows the total distance traveled)

- two tripmeters (which show the distance traveled since they were last set to zero)
- a clock
- an hour meter (which shows the total time the key has been turned to "ON")
- a voltage display (which shows the battery voltage)
- a fuel meter
- a self-diagnosis device



## Odometer and tripmeter modes

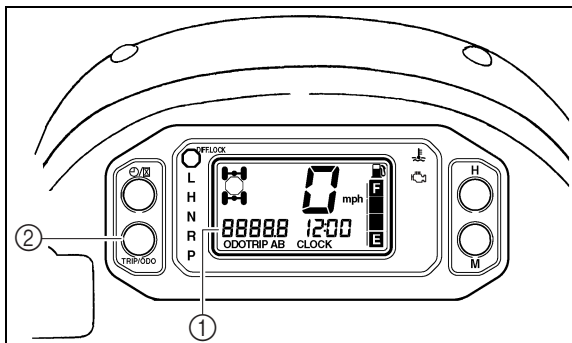

1. Odometer/Tripmeter A/Tripmeter B
2. "TRIP/ODO" button

Pushing the "TRIP/ODO" button switches the display between the odometer mode "ODO" and the tripmeter modes "A" and "B" in the following order:

ODO → TRIP A → TRIP B → ODO

To reset a tripmeter, select it by pushing the "TRIP/ODO" button, and then hold the "TRIP/ODO" button for at least three seconds. The tripmeters can be used to estimate the distance that can be traveled with a full tank of fuel. This information will enable you to plan future fuel stops.

To switch the display between "mph" and "km/h", push and hold the "TRIP/ODO" button while turning the key to "ON".

## Clock, hour meter and voltage display modes

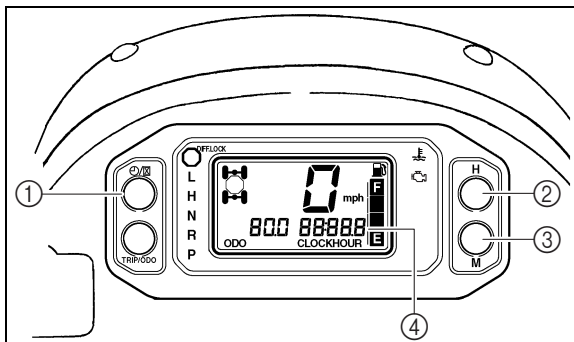

1. Clock/Hour button “🕒 / ⌚”
2. “H” button
3. “M” button
4. Clock/Hour meter/Voltage display

Pushing the “🕒 / ⌚” button switches the display between the clock mode “CLOCK”, the hour meter mode “HOUR”, and the voltage display mode “btry” in the following order:

CLOCK → HOUR → btry → CLOCK

## To set the clock

1. Set the display to the clock.
2. Push the “🕒 / ⌚” button until the clock starts flashing.
3. Set the hours by pushing the “H” button.
4. Set the minutes by pushing the “M” button.
5. Push the “🕒 / ⌚” button, and then release it to start the clock.

## Voltage display mode

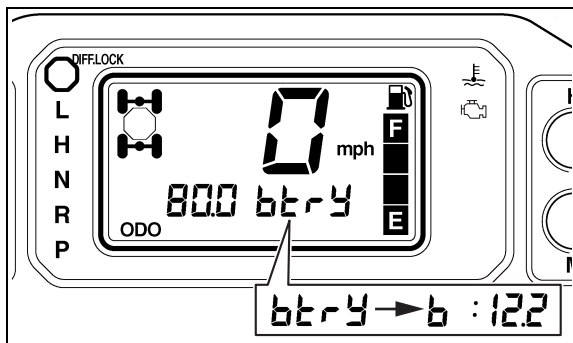

## **NOTICE**

If the voltage display indicates “LO” or “HI”, there may be trouble with the battery charging circuit or the battery may be faulty. If “LO” or “HI” appears in the display, have a Yamaha dealer check or repair the vehicle.

This display shows the battery voltage.

“btry” appears for 1 second when the voltage display mode is first selected, and then the battery voltage is shown.

If the battery voltage is less than 10 volts, “LO” is displayed and if the voltage is above 16 volts, “HI” is displayed.

## Fuel meter

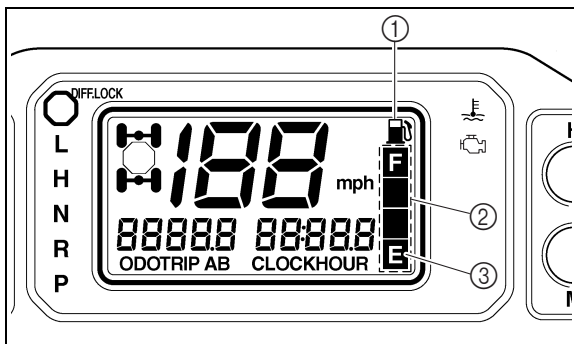

1. Fuel level warning indicator
2. Fuel meter
3. "E" segment

The fuel meter indicates the amount of fuel in the fuel tank. The display segments of the fuel meter disappear from "F" (full) towards "E" (empty) as the fuel level decreases. When the "E" segment disappears and the fuel level warning indicator flashes, refuel as soon as possible.

## TIP

This fuel meter is equipped with a self-diagnosis system. If the electrical circuit is defective, all the display segments and fuel level warning indicator will start flashing. If this occurs, have a Yamaha dealer check the electrical circuit.

## Self-diagnosis device

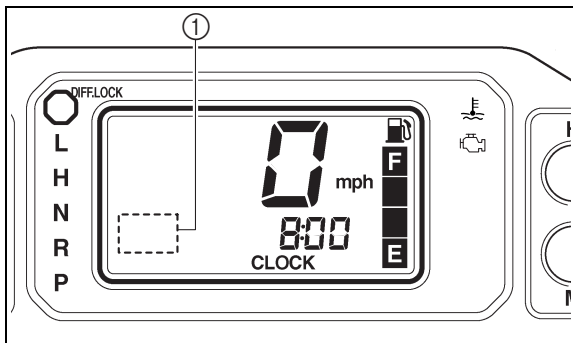

1. Error code display

This model is equipped with a self-diagnosis device for various electrical circuits.

If any of those circuits are defective, the engine trouble warning light will come on or flash, and then the multi-function display will indicate a two-digit error code.

If the multi-function display indicates such an error code, note the code number, and then have a Yamaha dealer check the vehicle.

## **NOTICE**

**If the multi-function display indicates an error code, the vehicle should be checked as soon as possible in order to avoid engine damage.**

## Switches

### Light switch “OFF/Ⓛ/Ⓜ”

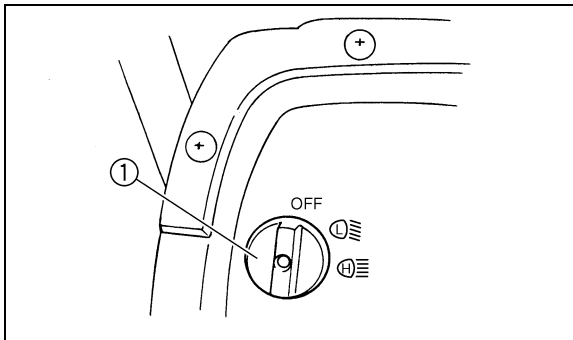

#### 1. Light switch “OFF/Ⓛ/Ⓜ”

Set the switch to “Ⓛ” to turn on the low beam and the taillights.

Set the switch to “Ⓜ” to turn on the high beam and the taillights.

Set the switch to “OFF” to turn off all the lights.

## ***NOTICE***

Do not use the headlights with the engine turned off for an extended period of time. The battery may discharge to the point that the starter motor will not operate properly. If this should happen, remove the battery and recharge it.

## On-Command four-wheel-drive and differential gear lock switches

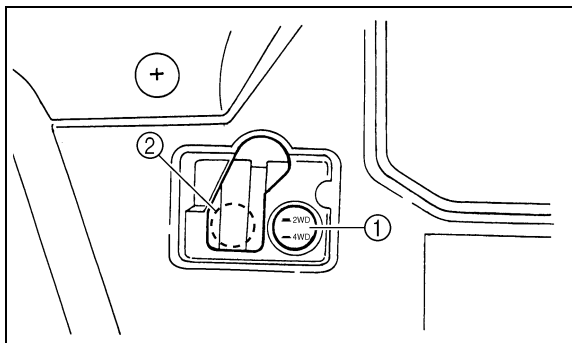

1. On-Command four-wheel-drive switch “2WD”/“4WD”
2. On-Command differential gear lock switch “4WD”/“LOCK”

This vehicle is equipped with an On-Command four-wheel-drive switch “2WD”/“4WD” and a differential gear lock switch “4WD”/“LOCK”. Select the appropriate drive according to terrain and conditions.

- Two-wheel drive (“2WD”): Power is supplied to the rear wheels only.

- Four-wheel drive (“4WD”): Power is supplied to the rear and front wheels.
- Four-wheel drive with the differential gear locked (“4WD-LOCK”): Power is supplied to the rear and front wheels with the differential gear locked. Unlike the 4WD mode, all wheels turn at the same speed regardless of traction.

## Accelerator pedal

Press the accelerator pedal down to increase engine speed. Spring pressure returns the pedal to the rest position when released. Always check that the accelerator pedal returns normally before starting the engine.

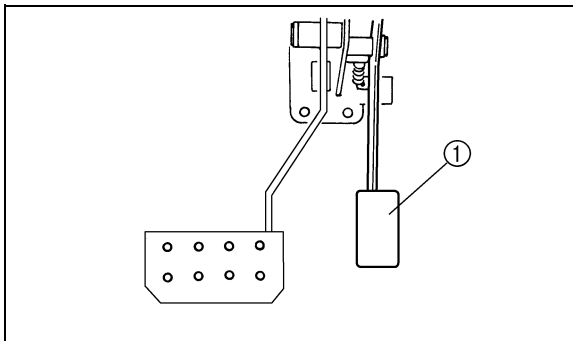

1. Accelerator pedal

## Brake pedal

Press the brake pedal to slow or stop the vehicle.

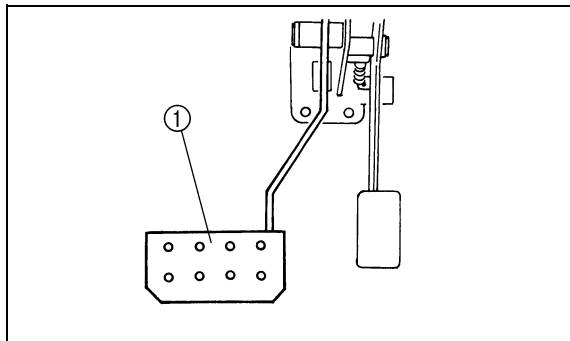

1. Brake pedal



## Parking brake lever

The parking brake lever is located at the right side of the driver's seat. It will help keep the vehicle from moving while parked.

To set the parking brake, pull the lever up completely.

To release the parking brake, pull up on the lever, press the release button, and then push the lever all the way down.

Spring pressure helps return the lever to the released position.

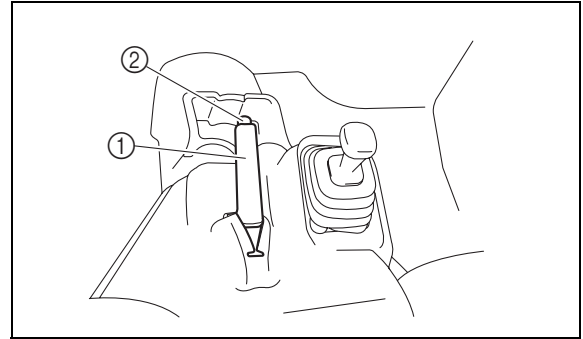

1. Parking brake lever

2. Release button

## Drive select lever

The drive select lever is used to shift the vehicle into the low, high, neutral, and reverse positions. (Refer to pages 6-4–6-5 for the drive select lever operation.)

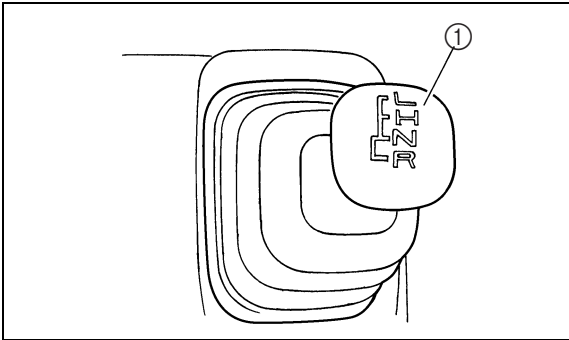

1. Drive select lever

## Fuel tank cap

Remove the fuel tank cap by turning it counterclockwise.

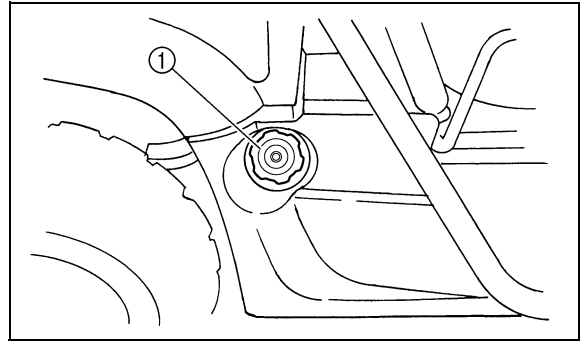

1. Fuel tank cap

## Doors

To open a door, simply pull the latch outward. To close a door, push or pull the door inward until it is securely latched. Be sure the door is **SECURELY LATCHED AFTER CLOSING IT.**

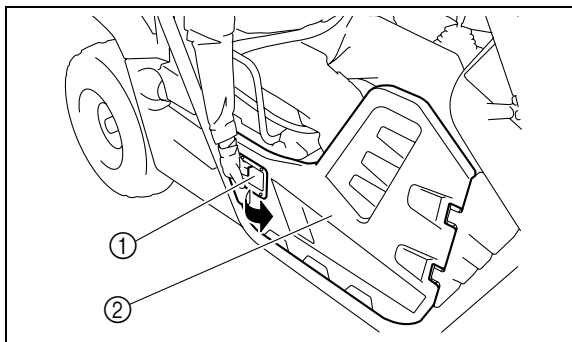

1. Latch

2. Door

## Seats

To remove a seat, pull its seat lock lever upward, lift the front of the seat, and then slide the seat forward and up.

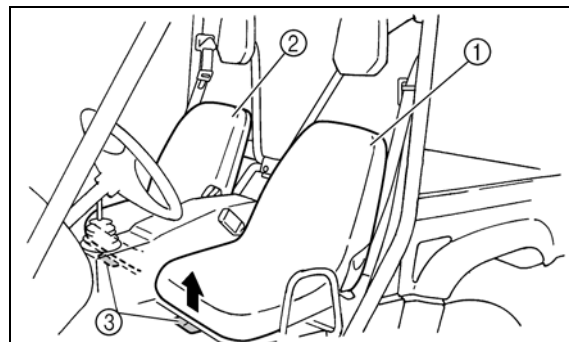

1. Driver seat

2. Passenger seat

3. Seat lock lever (× 2)

To install a seat, insert the projections on the rear of the seat into the seat holders and push down on the seat at the front. Make sure the seats are securely latched. **WARNING! A loose seat could cause the operator to lose control, or cause the operator or passenger to fall.**

### **Seat belts**

This vehicle is equipped with three-point seat belts for both the operator and the passenger. Always wear the seat belts properly while riding in the vehicle. See pages 7-6–7-8 for more information.

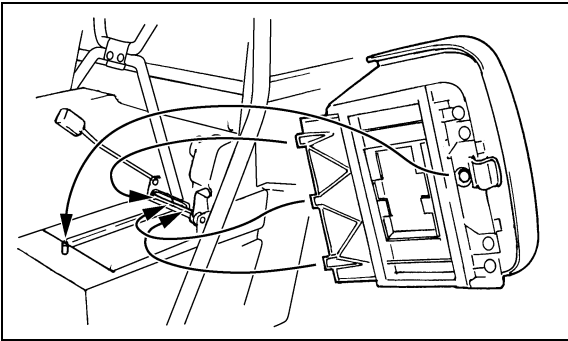

## Glove compartment

### **NOTICE**

To protect from damage, do not put metal products, like tools or sharply edged products, directly in the glove compartment. If they must be stored, wrap them in appropriate cushioning material.

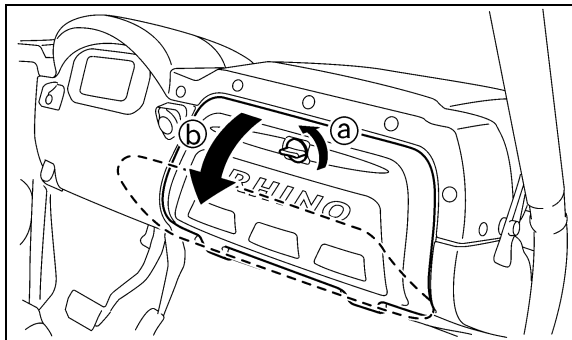

a. Unlock.

b. Open.

## Cup holders

Be sure to tightly close the cap of any plastic bottle before placing it in a cup holder.

Some plastic bottles may not fit into the cup holders depending on their size and shape.

### **⚠ WARNING**

- While the vehicle is moving, do not place any open or glass containers in the cup holders; otherwise, the contents may spill and the glass containers may break.
- Do not place any items, other than cups or plastic bottles, in the cup holders; otherwise, they may be thrown about and possibly injure people in the vehicle during sudden braking or an accident.

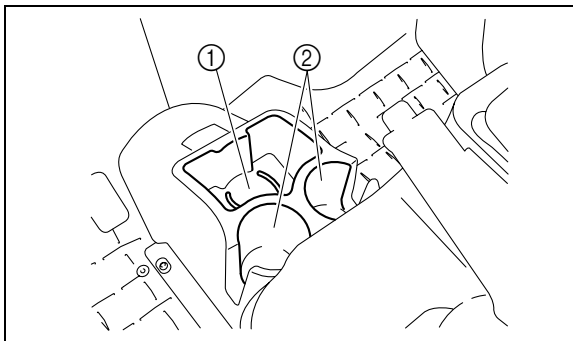

1. Storage/cup holder (× 1)

2. Cup holder (× 2)

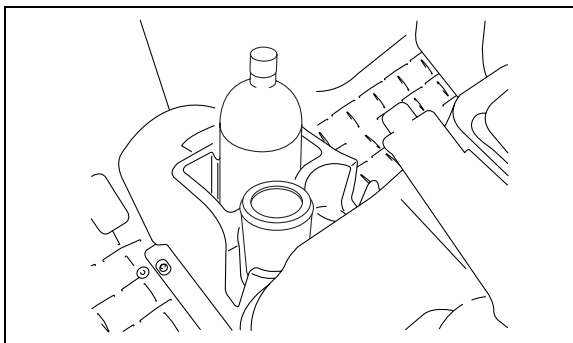

## Cargo bed

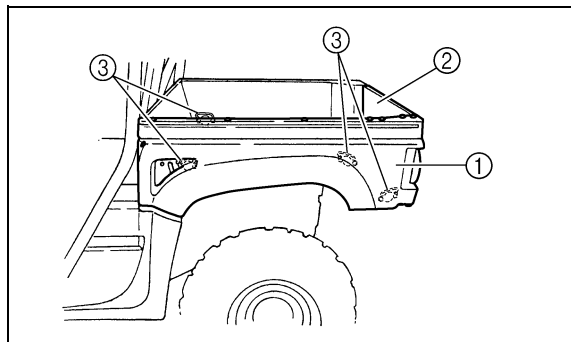

1. Cargo bed

2. Tailgate

3. Cargo hook (× 4)

Maximum load limit: 181 kg (400 lb)

For additional loading information, see pages 6-9-6-11.

## Opening and closing the tailgate

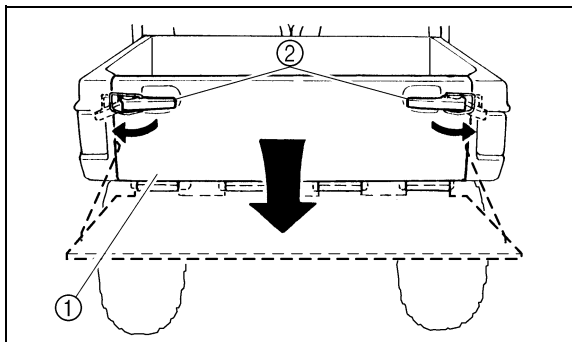

1. Tailgate

2. Latch (× 2)

### To open

Unhook the latches, and then lower the tailgate.

### To close

Place the tailgate in the original position, and then hook the latches.

## Lifting and lowering the cargo bed

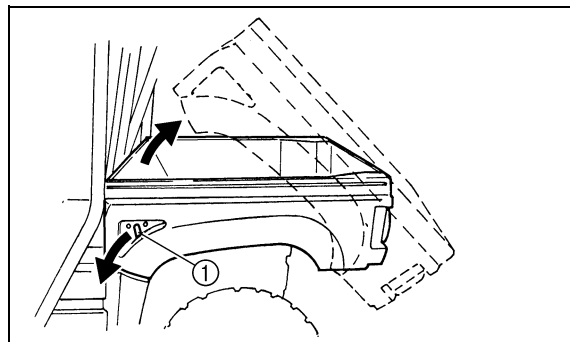

1. Cargo bed release lever

### To lift

Push down the cargo bed release lever on the left or right side of the vehicle, and then slowly lift up the cargo bed until it stops.

### To lower

With hands and fingers clear of pinch points, lower the cargo bed slowly to its original position and be sure it is locked into place.

**WARNING! Keep hands, body, and other people away from pinch points when lowering bed. Do not hold onto the cage/frame while closing the bed.**

### **Front and rear shock absorber adjustment**

The spring preload can be adjusted to suit the operating conditions. You can reduce preload for a softer ride, or increase preload if frequent bottoming occurs or when carrying loads.

#### **WARNING**

---

**Always adjust the shock absorbers on the left and right sides to the same setting. Uneven adjustment can cause poor handling and loss of stability, which could lead to an accident.**

---

#### ***NOTICE***

**Frequent or severe bottoming can cause increased wear or damage to the vehicle.**

The rear wheels need to be removed to adjust the rear shock absorber assemblies. (See pages 8-43–8-46 for wheel removal and installation procedures.)



Adjust the spring preload as follows:

To increase the spring preload, turn the adjusting ring in direction ①.

To decrease the spring preload, turn the adjusting ring in direction ②.

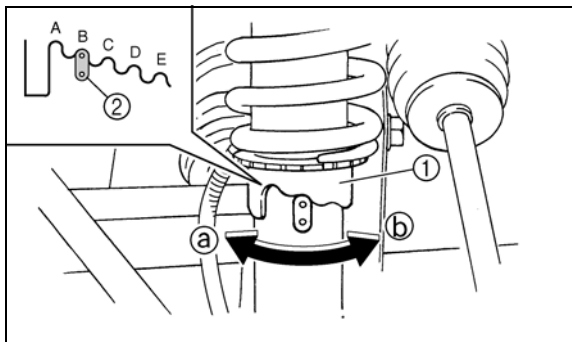

1. Spring preload adjusting ring
2. Position indicator

A special wrench can be obtained at a Yamaha dealer to make this adjustment.

Standard position: B  
A- Minimum (soft)  
E- Maximum (hard)

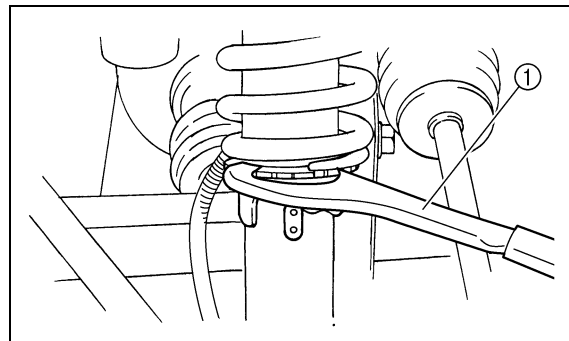

1. Special wrench

## Trailer hitch bracket and receiver

This vehicle is equipped with a trailer hitch bracket and a 5 cm (2 in) receiver for a standard trailer hitch. Trailer towing equipment can be obtained at a Yamaha dealer. (See pages 6-9–6-11 for precaution information.)

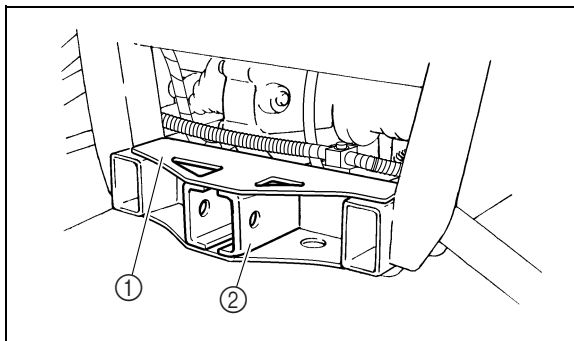

1. Trailer hitch bracket
2. Receiver

## Auxiliary DC jack

The auxiliary DC jack is located at the right side of the front panel. The auxiliary DC jack can be used for suitable work lights, radios, etc. The auxiliary DC jack should only be used when the engine is running.

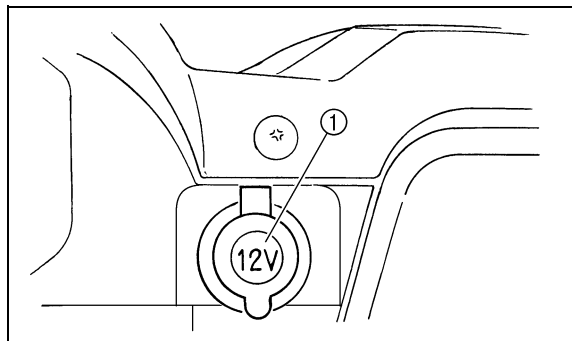

1. Auxiliary DC jack cap
1. Set the light switch to "OFF".
  2. Start the engine. (See pages 6-2–6-3.)
  3. Open the auxiliary DC jack cap, and then insert the accessory power plug into the jack.

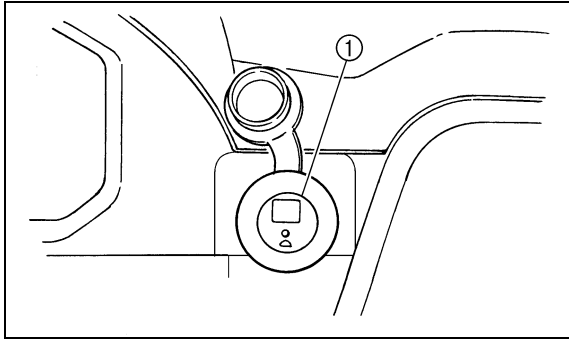

1. Auxiliary DC jack

Maximum rated capacity for the auxiliary  
DC jack:  
DC 12 V, 120 W (10 A)

4. When the auxiliary DC jack is not being used, cover it with the cap.

### ***NOTICE***

- Do not use accessories requiring more than the maximum capacity stated above. This may overload the circuit and cause the fuse to blow.
- If accessories are used without the engine running, the battery will lose its charge and engine starting may become difficult.
- Do not use an automotive cigarette lighter or other accessories with a plug that gets hot, because the jack can be damaged.

## FOR YOUR SAFETY – PRE-OPERATION CHECKS

Inspect your vehicle each time you use it to make sure the vehicle is in safe operating condition. Always follow the inspection and maintenance procedures and schedules described in the Owner's Manual.

### **WARNING**

**Failure to inspect or maintain the vehicle properly increases the possibility of an accident or equipment damage. Do not operate the vehicle if you find any problem. If a problem cannot be corrected by the procedures provided in this manual, have the vehicle inspected by a Yamaha dealer.**

Before using this vehicle, check the following points:

ITEM	ROUTINE	PAGE
<b>Brakes</b>	<ul style="list-style-type: none"><li>• Check operation, free play, fluid level, and fluid leakage.</li><li>• Fill with DOT 4 brake fluid if necessary.</li></ul>	5-3, 8-34–8-37, 8-39–8-40
<b>Parking brake</b>	<ul style="list-style-type: none"><li>• Check for proper operation, condition, and free play.</li></ul>	8-38–8-39
<b>Fuel</b>	<ul style="list-style-type: none"><li>• Check fuel level.</li><li>• Fill with fuel if necessary.</li></ul>	5-4–5-5
<b>Engine oil</b>	<ul style="list-style-type: none"><li>• Check oil level.</li><li>• Fill with oil to proper level if necessary.</li></ul>	5-6, 8-10–8-15
<b>Coolant reservoir</b>	<ul style="list-style-type: none"><li>• Check coolant level.</li><li>• Fill with coolant if necessary.</li></ul>	5-7, 8-21–8-22

ITEM	ROUTINE	PAGE
<b>Final gear oil/ Differential gear oil</b>	• Check for leakage.	5-7, 8-16–8-21
<b>Accelerator pedal</b>	• Check for proper accelerator pedal operation.	5-8
<b>Seat belts</b>	• Check for proper operation and belt wear.	5-8
<b>Steering</b>	• Check for proper operation.	5-8
<b>Fittings and fasteners</b>	• Check all fittings and fasteners.	5-8
<b>Lights and switches</b>	• Check for proper operation.	5-9, 8-53–8-57
<b>Wheels and tires</b>	• Check tire pressure and for wear and damage.	5-9–5-11, 8-43–8-46
<b>Axle boots</b>	• Check for damage.	8-23

## Front and rear brakes

### Brake pedal

Check for correct brake pedal free play. If the brake pedal free play is incorrect, have a Yamaha dealer adjust it. (See page 8-37.)

Check the operation of the brake pedal. It should move smoothly and there should be a firm feeling when the brakes are applied. If not, have the vehicle inspected by a Yamaha dealer.

### Brake fluid level

Check the brake fluid level. Add fluid if necessary. (See pages 8-36–8-37.)

Recommended brake fluid: DOT 4
--------------------------------

### Brake fluid leakage

Check to see if any brake fluid is leaking out of the pipe joints or the brake fluid reservoir. Apply the brakes firmly for one minute. If there is any leakage, have the vehicle inspected by a Yamaha dealer.

### Brake operation

Check the operation of the brakes at the start of every ride. Test the brakes at slow speed after starting out to make sure they are working properly. If the brakes do not provide proper braking performance, inspect the brake system. (See pages 8-34–8-35, 8-37–8-40.)

## Fuel

Make sure there is sufficient gasoline in the tank.

### **WARNING**

**Gasoline and gasoline vapors are extremely flammable. To avoid fires and explosions and to reduce the risk of injury when refueling, follow these instructions.**

1. Before refueling, turn off the engine and be sure that driver and passenger are outside the vehicle.  
Never refuel while smoking, or while in the vicinity of sparks, open flames, or other sources of ignition such as the pilot lights of water heaters and clothes dryers.
2. Do not overfill the fuel tank. Because fuel expands when it heats up, heat from the engine or the sun can cause fuel to spill out of the fuel tank.
3. Wipe up any spilled fuel immediately.

4. Be sure the fuel tank cap is closed securely.

### **WARNING**

**Gasoline is poisonous and can cause injury or death. Handle gasoline with care. Never siphon gasoline by mouth. If you should swallow some gasoline or inhale a lot of gasoline vapor, or get some gasoline in your eyes, see your doctor immediately. If gasoline spills on your skin, wash with soap and water. If gasoline spills on your clothing, change your clothes.**

Your Yamaha engine has been designed to use regular unleaded gasoline with a pump octane number ( $([R+M]/2)$ ) of 86 or higher, or research octane number of 91 or higher. If knocking or pinging occurs, use a different brand of gasoline or premium unleaded fuel. Unleaded fuel will give you longer spark plug life and reduced maintenance cost.

## Gasohol

There are two types of gasohol: gasohol containing ethanol and that containing methanol. Gasohol containing ethanol can be used if ethanol content does not exceed 10%. Gasohol containing methanol is not recommended by Yamaha because it may cause fuel system damage or vehicle performance problems.

Recommended fuel:

Unleaded gasoline only

Fuel tank capacity:

30.0 L (6.60 Imp gal, 7.93 US gal)

## Portable gas containers

If you carry a portable gas can in the bed of the Rhino, be sure to secure it with the cap tightened before driving the vehicle.

Always place a portable gas container on the ground before filling it. Before removing the container cap, touch the container with the gas dispenser nozzle. Keep gas dispenser nozzle in contact with container inlet when filling. **WARNING! Never refill a fuel container in the bed of any vehicle. Fire may result from a build-up of static electricity. The discharge of this build-up while refueling can cause a spark and ignite the gasoline.**



## Engine oil

Make sure the engine oil is at the specified level. Add oil as necessary. (See pages 8-10–8-15.)

### **NOTICE**

- In order to prevent clutch slippage (since the engine oil also lubricates the clutch), do not mix any chemical additives with oil. Do not use oils with a diesel specification of “CD” or oils of a higher quality than specified. In addition, do not use oils labeled “ENERGY CONSERVING II” or higher.
- Make sure that no foreign material enters the crankcase.

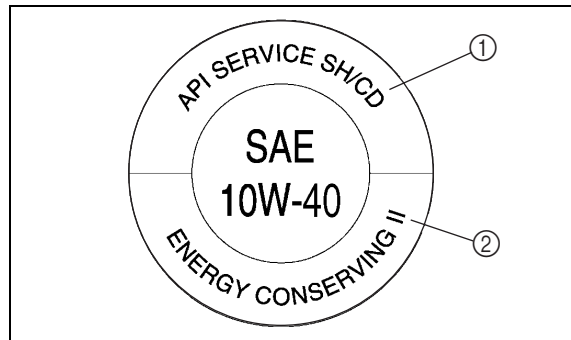

1. “CD” specification
2. “ENERGY CONSERVING II”

Recommended engine oil type and quantity:  
See page 10-2.

## Coolant

Check the coolant level in the coolant reservoir when the engine is cold (the coolant level will vary with engine temperature).

The coolant level is satisfactory if it is between the minimum and maximum level marks on the coolant reservoir. If the coolant level is at or below the minimum level mark, add additional coolant to bring the level up to maximum level mark. If coolant is not available, add distilled water. Change the coolant every two years. (See pages 8-21–8-22 for details.)

### **NOTICE**

**Hard water or salt water is harmful to the engine. You may use soft water if you cannot get distilled water.**

Coolant reservoir capacity  
(up to the maximum level mark):  
0.32 L (0.28 Imp qt, 0.34 US qt)

## Final gear oil

Make sure the final gear oil is at the specified level. Add oil as necessary. (See pages 8-16–8-18 for details.)

Recommended oil:  
SAE 80 API GL-4 Hypoid gear oil

If desired, an SAE 80W90 hypoid gear oil may be used for all conditions.

### **TIP**

GL-4 is a quality and additive rating; GL-5 or GL-6 rated hypoid gear oils may also be used.

## Differential gear oil

Make sure the differential gear oil is at the specified level. Add oil as necessary. (See pages 8-19–8-21 for details.)

Recommended oil:  
SAE 80 API GL-4 Hypoid gear oil

### **Accelerator pedal**

Check to see that the accelerator pedal operates correctly. It must operate smoothly and spring back to the idle position fully when released. Have a Yamaha dealer repair as necessary for proper operation.

### **Seat belts**

Make sure that the seat belts are not frayed, torn, stretched, or damaged. The seat belt must move smoothly when pulled out and retract on its own when released. It must also lock up when quickly pulled out. The latch plate should click securely into the buckle and release when the release button is pushed firmly. Wash off any dirt or mud that could affect operation. Have a Yamaha dealer repair as necessary for proper operation.

A crash can damage the restraint systems in your vehicle. A damaged restraint system may not properly protect the person using it, resulting in serious injury or death in a crash. To help make sure your restraint systems are working properly after a crash, have them inspected and any necessary replacements made as soon as possible.

### **Steering**

Park on level ground. Turn the steering wheel right and left. Check for excessive free play, abnormal noises, or a rough feeling. Have a Yamaha dealer repair as necessary for proper operation.

### **Fittings and fasteners**

Always check the tightness of chassis fittings and fasteners before a ride. Take the vehicle to a Yamaha dealer or refer to the Service Manual for correct tightening torque.

## Lights

Check the headlights and tail/brake lights to make sure they are in working condition. Repair as necessary for proper operation.

## Switches

Check the operation of all switches. Have a Yamaha dealer repair as necessary for proper operation.

## Control cables

When riding in cold weather, always make sure all control cables work smoothly before you begin riding. **WARNING! Control cables can freeze in cold weather and you could be unable to control the vehicle.**

## Tires

Check tire pressure regularly to make sure it is at the recommended specifications. Also check for wear and damage.

## Tire pressure

Use the tire pressure gauge to check and adjust tire pressures when the tires are cold. Tire pressures must be equal on both sides. **WARNING! Operation of this vehicle with improper tire pressure may cause severe injury or death from loss of control or roll-over. Tire pressure below the minimum specified could also cause the tire to dislodge from the rim under severe riding conditions.**

Set tire pressures to the following specifications:

	Recommended pressure	Minimum	Maximum
Front	70 kPa (0.70 kgf/cm <sup>2</sup> , 10 psi)	63 kPa (0.63 kgf/cm <sup>2</sup> , 9 psi)	77 kPa (0.77 kgf/cm <sup>2</sup> , 11 psi)
Rear	98 kPa (0.98 kgf/cm <sup>2</sup> , 14 psi)	91 kPa (0.91 kgf/cm <sup>2</sup> , 13 psi)	105 kPa (1.05 kgf/cm <sup>2</sup> , 15 psi)

The tire pressure gauge is included as standard equipment. Make two measurements of the tire pressure and use the second reading. Dust or dirt in the gauge could cause the first reading to be incorrect.

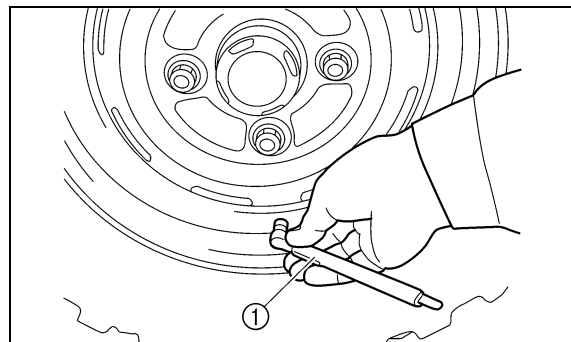

1. Tire pressure gauge

## Tire wear limit

When the tire groove decreases to 3 mm (0.12 in) due to wear, replace the tire.

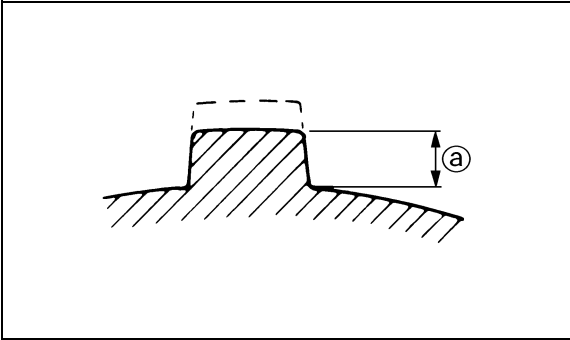

a. Tire wear limit

## OPERATION

Read the Owner's Manual carefully to become familiar with all controls. If there is a control or function you do not understand, ask your Yamaha dealer.

### **WARNING**

**Failure to familiarize yourself with the controls can lead to loss of control, which could cause an accident or injury.**

### **Engine break-in**

There is never a more important period in the life of your vehicle than the period between zero and 20 hours.

For this reason, we ask that you read the following material carefully. Because the engine is brand new, you must not put an excessive load on it for the first several hours of operation. During the first 20 hours, the various parts in the engine wear and polish themselves to achieve the correct operating clearances.

During this period, prolonged full-throttle operation or any condition that might result in excessive engine heating must be avoided. However, momentary (2–3 seconds maximum) full-throttle operation under load does not harm the engine.

Each full-throttle acceleration sequence should be followed with a substantial rest period for the engine, by cruising at lower r/min so the engine can rid itself of the temporary build-up of heat. If any abnormality is noticed during this period, consult a Yamaha dealer.

### **0–10 hours:**

Avoid continuous operation above half-throttle. Allow a cooling-off period of five to ten minutes after every hour of operation. Vary the speed of the vehicle from time to time. Do not operate it at one set throttle position.

### **10–20 hours:**

Avoid prolonged operation above three-quarter throttle.

### **After break-in:**

The vehicle may now be operated normally.

## **Starting the engine**

1. Turn the main switch to “ON”.

### ***NOTICE***

**The coolant temperature warning light and engine trouble warning light should come on, then go off.**

**If a warning light does not go off, see page 4-4 for the corresponding warning light circuit check.**

2. Apply the brake pedal.
3. Shift the drive select lever into the neutral position.
  - When the drive select lever is in the neutral position, the neutral indicator light should come on. If the neutral indicator light does not come on, ask a Yamaha dealer to inspect the electric circuit.



- The engine can be started in any gear if the brake is applied. However, it is recommended to shift into neutral before starting the engine.
4. With your foot off the accelerator pedal, start the engine by turning the key to “START”.

If the engine fails to start, release the key, and then try starting it again. Wait a few seconds before the next attempt. Each attempt should be as short as possible, to preserve battery energy. **NOTICE: Do not crank the engine more than 5 seconds on each attempt, or starter damage could occur. Wait at least 5 seconds between each operation of the electric starter to let it cool.**

Do not turn the key to the “START” position with the engine running, or damage to the electric starter may result.

### **TIP**

For maximum engine life, never accelerate hard when the engine is cold!

## Drive select lever operation and reverse driving

### **NOTICE**

Do not shift without coming to a complete stop and waiting for the engine to return to normal idle speed. Damage to the engine or drive train may occur.

### Shifting: neutral to high and high to low

1. Stop the vehicle. Take your foot off the accelerator pedal.

2. Apply the brake pedal, then shift by moving the drive select lever along the shift guide. Make sure that the drive select lever is completely shifted into position.

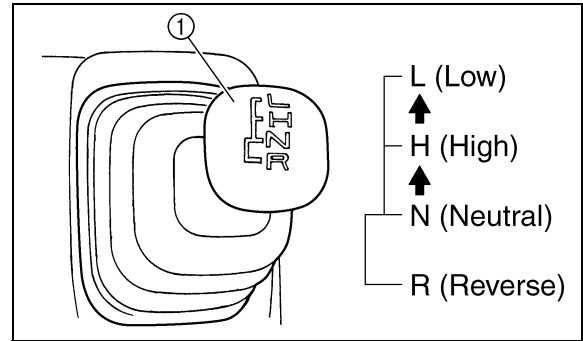

1. Drive select lever

3. Release the brake pedal and press the accelerator pedal gradually.

## Shifting: neutral to reverse

### **⚠ WARNING**

**Before you shift into reverse, make sure there are no obstacles or people behind you. When it is safe to proceed, go slowly. Hitting an obstacle or person could result in serious injury or death.**

1. Stop the vehicle. Take your foot off the accelerator pedal and check behind you.
2. Apply the brake pedal.
3. Shift from neutral to reverse or vice versa by moving the drive select lever along the shift guide.
  - When in reverse, the reverse indicator light should be on. Due to the synchronizing mechanism in the engine, the light may not come on until the vehicle starts moving.
  - If the light does not come on, ask a Yamaha dealer to inspect the reverse indicator light electrical circuit.

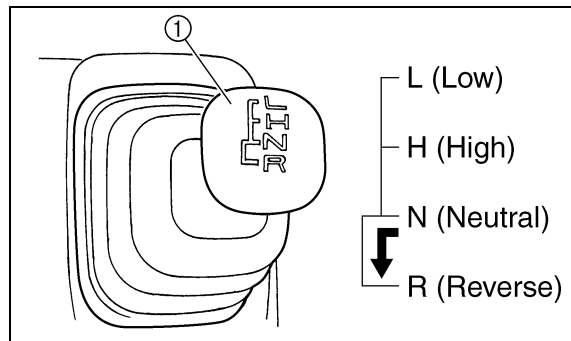

1. Drive select lever
4. Check behind the vehicle for people or obstacles, and then release the brake pedal.
5. Press the accelerator pedal gradually and continue to watch to the rear while backing.

## On-Command four-wheel-drive switch and differential gear lock switch

You may notice that the vehicle handles differently in 2WD, 4WD, and 4WD-LOCK (“DIFF. LOCK”). For example, you should expect that the vehicle will require more effort to turn in 4WD-LOCK (“DIFF. LOCK”). Always stop the vehicle before changing between 2WD and 4WD or 4WD and 4WD-LOCK (“DIFF-LOCK”).

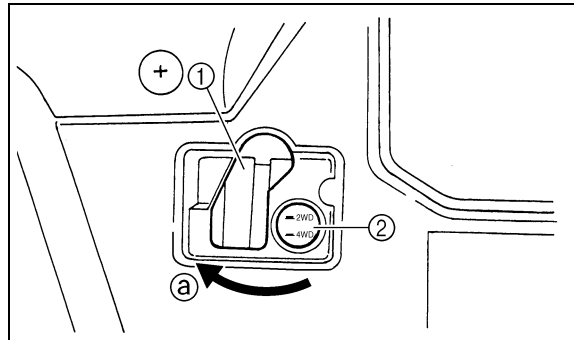

1. Differential gear lock lever
2. On-Command four-wheel-drive switch “2WD”/“4WD”

## “2WD”/“4WD”

To change from 2WD to 4WD, stop the vehicle, and then set the switch to “4WD”. When the vehicle is in 4WD, the four-wheel-drive indicator “” will come on in the multi-function display. To change from 4WD to 2WD, stop the vehicle, be sure the differential gear lock lever is set to position (a), and then set the switch to “2WD”.

## On-Command differential gear lock switch “4WD”/“LOCK”

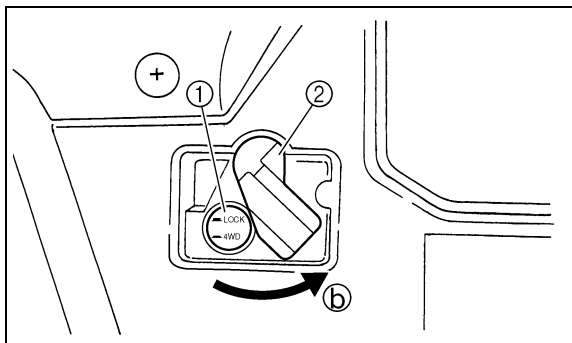

1. On-Command differential gear lock switch “4WD”/“LOCK”
2. Differential gear lock lever

To lock the differential gear in 4WD, stop the vehicle, make sure the On-Command four-wheel-drive switch is set to “4WD”, move the differential gear lock lever to position (b), and then set the switch to “LOCK”. When the differential gear is locked, the differential gear lock indicator light (“DIFF. LOCK”) will come on along with the differential gear lock indicator “” in the multi-function display. To release the differential gear lock, stop the vehicle and set the switch to “4WD”.

- When the switch is set to “LOCK”, the differential gear lock indicator and indicator light will flash until the differential gear is locked.
- When the indicator and indicator light are flashing, turning the steering wheel back and forth will help the differential gear lock to engage.

- Driving before the differential gear lock is properly engaged (e.g., when the indicator and indicator light are flashing) will cause the engine speed to be limited until engagement is complete.

### **Parking**

When parking, stop the engine and shift the drive select lever into the neutral position. Apply the parking brake to help prevent the vehicle from rolling. See pages 7-17–7-18 for more information on parking and parking on a slope.

## Loading

Take extra precautions when driving with a load or trailer. Follow these instructions and always use common sense and good judgment when carrying cargo or towing a trailer.

### Prepare your load or trailer

#### **WARNING**

Improper loading or towing can increase the risk of loss of control, an overturn, or other accident:

- Do not exceed the Maximum Loading Limits for the vehicle (see box or vehicle labeling).
- Keep weight in the cargo bed centered side to side, and as low and as far forward as possible. Top-heavy loads increase the risk of overturn. Be sure cargo is secured – a loose load could change handling unexpectedly or strike occupants.

- Do not exceed the maximum tongue weight.
  - Make sure the load does not interfere with your control or ability to see where you are going.
  - Tie down cargo in the trailer securely. Make sure cargo in the trailer cannot move around. A shifting load can cause an accident.
-

Use the hooks equipped on the cargo bed to tie down loads.

Choose a trailer hitch drawbar designed for use with a 5 cm (2 in) receiver. (See page 4-23 for more information.)

You can measure tongue weight with a bathroom scale. Put the tongue of the loaded trailer on the scale with the tongue at hitch height. Adjust the load in the trailer, if necessary, to reduce the weight on hitch. If you are carrying cargo and towing a trailer, include the tongue weight in the maximum vehicle load limit.

#### **MAXIMUM LOADING LIMIT**

- Vehicle loading limit (total weight of cargo, operator, passenger and accessories and tongue weight): 367 kg (809 lb)
- Cargo bed: 181 kg (400 lb)
- Trailer hitch:
  - Pulling load (total weight of trailer and cargo): 550 kg (1,212 lb)
  - Tongue weight (vertical weight on trailer hitch point): 50 kg (110 lb)



## **Operating when loaded with cargo or towing a trailer**

Drive more slowly than you would without a load. The more weight you carry, the slower you should go. Although conditions vary, it is good practice to keep the vehicle in low gear whenever you are carrying heavier loads or when towing a trailer.

### **WARNING**

**Carrying loads or towing a trailer can increase the risk of loss of control, an overturn, or other accident. To reduce the risk of an accident:**

- **Reduce speed, operate in low gear only, and allow more room to stop. A heavier vehicle takes longer to stop.**
- **Avoid hills and rough terrain. Choose terrain carefully. Use extreme caution when towing or carrying a load on inclines.**
- **Turn gradually and go slowly.**

## **Pulling something other than a trailer**

Yamaha recommends that loads be transported in the bed or in a trailer. If you need to move an object a short distance use a winch and follow the winch manufacturer's instructions.

If you choose to use something other than a winch use extreme caution, follow the manufacturer's instructions for that product, and only attach to the hitch or hitch bracket of the Rhino. **WARNING! Improperly pulling can cause serious injury or death. Never exceed the Pulling Load limit of the Rhino. Avoid pulling on inclines.**

Pulling objects on the ground can be more hazardous than pulling a trailer. It may be difficult to predict how the load will affect vehicle operation. That effect could also change depending upon terrain or what obstacles might be in the object's path.



## **BASIC GUIDE FOR SAFE USE**

As a Rhino owner you are responsible for the safe and proper operation of this vehicle. Read this chapter and review the safety instructions in Chapter 2 before operating the vehicle. Use these chapters and the labels on the vehicle to instruct new operators and passengers. Do not allow anyone else to operate the vehicle or ride as a passenger if you are unsure that he/she is willing and able to follow these instructions.

### **WARNING**

**Follow these instructions to reduce your risk of an accident and to reduce the risk of serious injury or death in the event of an accident.**

---

## **KNOW YOUR VEHICLE**

This off-road vehicle will handle and maneuver differently from cars, ATVs, go-carts, golf-cars and grounds-keeping vehicles. The Rhino has higher ground clearance and other features to handle rugged terrain, and, as a result, can overturn in situations where some vehicles may not. This would include vehicles made primarily for pavement, roads, improved paths, or grounds-keeping. If you do not use care in maneuvering the Rhino, you can cause it to roll over even on flat, open areas.

Doing things with a Rhino that some people do for thrills in other vehicles (such as side-ways sliding, skidding, fishtailing, or donuts) have led to side rollovers. These rollovers can result in crushed limbs and other serious injuries or death to drivers or passengers.

As the owner/operator, it is your responsibility to protect yourself and your passenger from accidents, including rollovers. The Rhino has many features, including a protective structure and seat belts, to help protect occupants, but the best way to avoid injuries is to avoid accidents. There is a risk of injury or death in any accident, even with these safety features.

## Driver requirements

- This vehicle is intended for use only by an operator 16 or older with a valid motor vehicle license.



- The driver must be able to place both feet flat on the floorboard while seated upright with his/her back against the seat back.
- Do not drive after using drugs or alcohol.

Remove the ignition key when the vehicle is not in use to prevent unauthorized use of the machine.

## Parents:

Many states have implemented new motor vehicle licensing requirements for young drivers. These requirements are in response to the disproportionately high rate of crashes involving youthful drivers. As with automobiles, to promote safe driving behaviors, you should supervise younger drivers and consider setting rules and putting limits on how, when, and where the Rhino can be used.

## Passenger requirements

This vehicle is designed for the operator and one passenger. Carrying passengers improperly can lead to serious injury or death. As the operator, you are responsible for your passenger.

- Your passenger must be able to place both feet on the floorboard while seated upright with his/her back against the seat back.
- Allow only one passenger in the vehicle and only in the passenger seat. Do not carry any other passengers. Do not carry passengers in the cargo bed.
- Do not allow someone to ride as a passenger who has been using drugs or alcohol.

## Occupant protection system

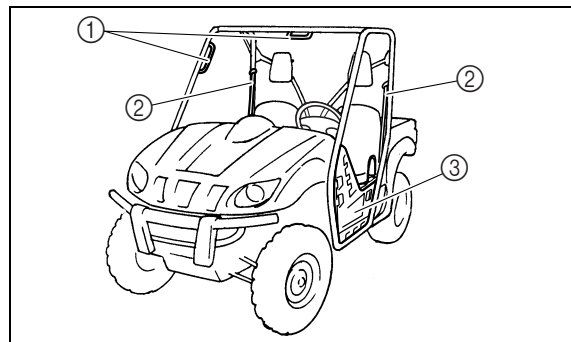

1. Passenger handhold
2. Seat belt
3. Door

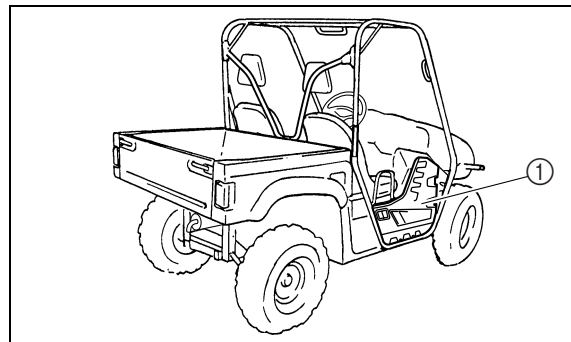

1. Door

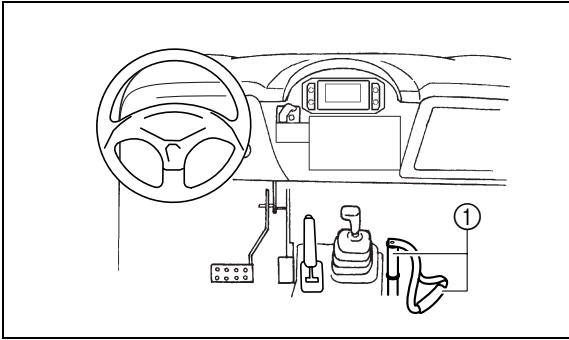

1. Passenger handhold

## **⚠ WARNING**

**Do not make changes to the occupant protection system. If you install aftermarket products or have your vehicle modified, you may put yourself and others at greater risk of serious injury or death. You are responsible for any such changes to the vehicle.**

The Rhino comes with a variety of features to help reduce the risk of driver and passenger injury. These features work together, and when properly used, these features will help protect the occupants in the event of an accident. If these features are not used properly, they can cause injury.

## **Protective structure**

The vehicle cage/frame provides a protective structure that helps limit intrusions by branches or other objects and may reduce your risk of injury in accidents. The protective structure will not protect occupants in all rollovers or accidents.

Body parts outside of vehicle can be struck by passing objects or crushed during vehicle rollover. Do not put your hands or feet outside of the vehicle for any reason. Do not hold onto the door, cage/frame or hip restraint bar. Wear your seat belt and helmet.

If you think or feel that the vehicle may tip or roll, do not put your hands or feet outside the vehicle for any reason. You will not be able to stop the vehicle from tipping over using your body. Any part of your body (arms, legs, or head) outside of the vehicle can be crushed by the vehicle cage/frame.

## **Seat belts**

Seat belts should be worn by both driver and passenger. Driver must be sure that the passenger is belted before driving.

- Be sure the seat belt is not twisted, is close-fitting across the hips and chest, and is latched securely.
- Do not wear the lap belt across the abdomen or stomach.
- Do not put the shoulder belt behind the back.

Failure to use seat belts properly may lead to an increased likelihood and severity of injury.

An unbelted occupant may strike the interior of the vehicle, the protective structure, or other objects in an accident or during operation. You may also fall completely out or be partially ejected from the vehicle, which may lead to being crushed between the ground and the vehicle. Wearing the seat belt helps you remain in the vehicle – the doors and handholds are not a substitute for using a seat belt.

A crash can damage the restraint systems in your vehicle. A damaged restraint system may not properly protect the person using it, resulting in serious injury or death in a crash. To help make sure your restraint systems are working properly after a crash, have them inspected and any necessary replacements made as soon as possible.

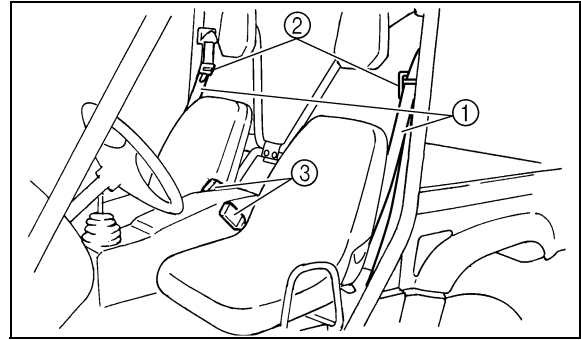

1. Seat belt (× 2)
3. Buckle (× 2)

2. Latch plate (× 2)

To wear the seat belt properly, do the following:

1. Hold the latch plate as you pull the belt across your lap and chest. Make sure the belt is not twisted and is not caught on any portion of the vehicle, your clothing, or any equipment you are carrying.



2. If the latch plate is not positioned in the correct location along the seat belt, squeeze the latch plate ends together along its long edges in order to more easily adjust its location up or down along the length of the belt.
3. Push the latch plate into the buckle until it clicks. Pull up on the latch plate to make sure it is secure.

4. Put the lap portion of the belt low on your hips. Pull up on the shoulder part so the belt is snug across your hips.
5. Position the shoulder belt over your shoulder and across your chest. The shoulder belt should fit against your chest. If it is loose, pull the belt out all the way and then let it retract.
6. To release the buckle, firmly press the release button.

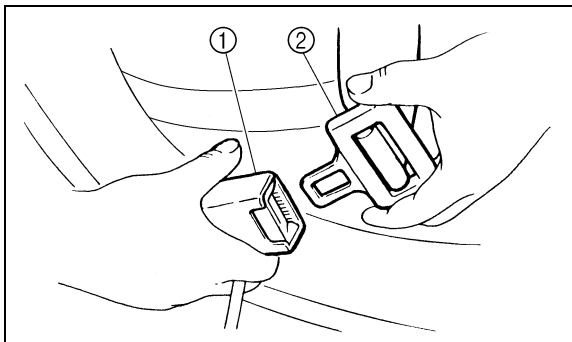

1. Buckle

2. Latch plate

## Doors

The doors are designed to reduce the likelihood that you will stick your leg out to stop the vehicle from tipping over or for any other reason in a rollover. The doors may also reduce intrusion of objects into the occupant area. Make sure the door is securely latched before operation. Do not place your arm or hand on the door during operation. Your hand or arm may be struck by objects or crushed against outside objects or the ground during a rollover.

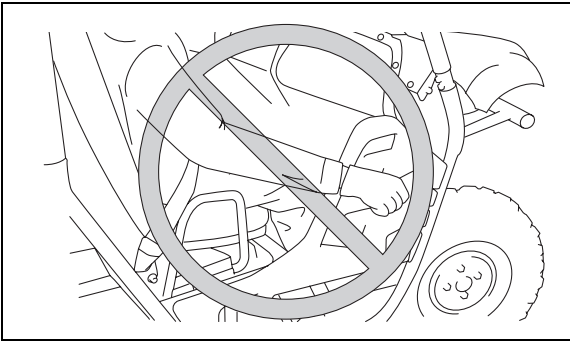

## Passenger handholds

Handholds are provided to grip during operation to maintain proper position and balance. Holding onto the handholds helps to reduce the likelihood that the passenger puts a hand outside the vehicle if the vehicle begins to tip. There are two handholds on the protective structure and two handholds on the passenger's left side, for the right and left hands.

The driver should make sure the passenger is holding onto the handholds with both hands before operating the vehicle.

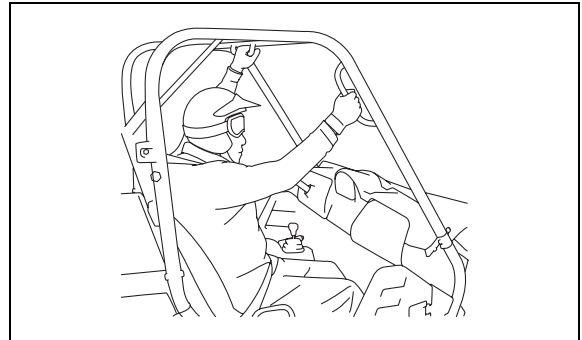

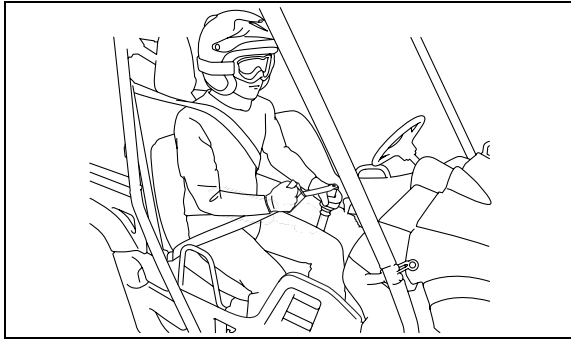

### **Seat and hip restraints**

The seat and hip restraints are designed to help keep you in the vehicle. Do not hold onto hip restraint bar when the vehicle is moving. Your hand or arm may be struck by objects or crushed against outside objects or the ground during a rollover.

## **Floorboard**

The floorboard allows you to brace your feet, which helps you keep your body in the vehicle in the event of an accident or rollover. Keep your feet on the floorboard during operation.

## **Steering wheel**

Keep both hands on the steering wheel. Do not hold the steering wheel with your thumbs inside the rim. Keep your palms on the outside of the steering wheel. Similar to other off-road vehicles, if the Rhino hits a deep rut or large obstacle, the steering wheel could briefly jerk in one direction or back and forth as the tires and vehicle respond to the obstacle. This quick motion could injure your thumbs or wrist if your thumbs or hand(s) are inside the steering wheel. Grip the steering wheel so that your thumbs will not be hit by the spokes. As an example, see the illustration.

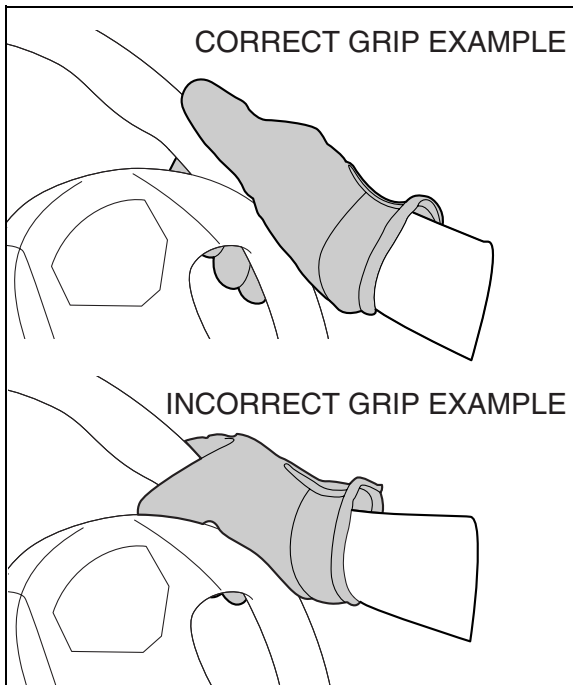

## LEARNING TO OPERATE YOUR VEHICLE

### Personal protective equipment

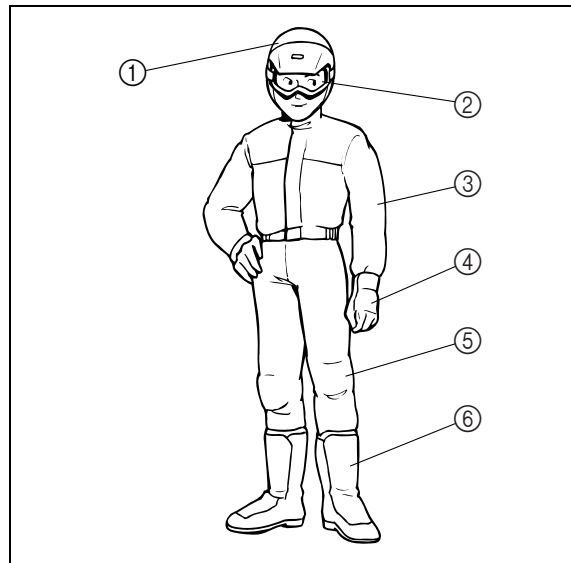

1. Approved motorcycle helmet
2. Eye protection
3. Long-sleeved shirt or jacket
4. Gloves
5. Long pants
6. Over-the-ankle boots

Both driver and passenger should wear the following to reduce risk of injury in an accident:

- Approved motorcycle helmet that fits properly
- Eye protection (goggles, helmet face shield, or protective eyewear)
- Over-the-ankle boots, gloves, long-sleeved shirt or jacket, and long pants

An approved helmet and other personal protective equipment can help in a variety of ways, including:

- Reduce the severity of injuries if any part of you is outside the vehicle cage/frame protective structure during a rollover.
- Help protect you if outside objects intrude inside the vehicle during operation.
- Help protect you in the event of vehicle impact with an obstacle.

Wear eye protection when operating or riding the vehicle to reduce the risk of a serious accident or injury. Eye protection, such as a face shield or goggles, may reduce the risk of foreign material getting in your eyes and help prevent loss of vision.

### **Practice for new Rhino users**

You should become familiar with the performance characteristics of the vehicle in a large, flat area that is free of obstacles and other vehicles. Practice controlling the accelerator pedal, brakes, steering, and drive select lever. Drive at slow speeds with gradual acceleration and turning. Practice smooth throttle application. Practice slowing down before turning. Practice maintaining a steady throttle through the turn. Avoid higher speeds until you are thoroughly familiar with the operation of your vehicle. Remember, driving aggressively or making abrupt maneuvers even on flat, open areas can cause side rollovers.

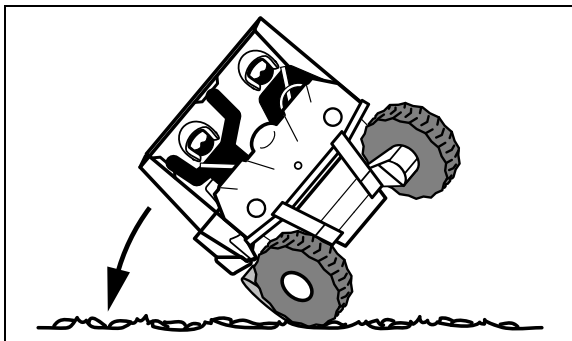

## Getting ready to ride

Perform the Pre-Operation Checks on pages 5-1–5-11. Follow the instructions starting on pages 6-2–6-3 to start the engine.

Become familiar with the way the vehicle feels in low and high ranges, first in two-wheel drive (2WD) and then in four-wheel drive (4WD) and four-wheel drive with the differential locked (DIFF. LOCK). Steering may take more effort in 4WD with the differential locked (DIFF. LOCK). Also practice driving in reverse.

Take the time to learn basic operation of the vehicle before attempting more difficult maneuvers.

## Turning

Use care in turns – turning the steering wheel too far or too fast can result in loss of control or a rollover. Slow down before entering turns. When making tight turns from a standstill or at slow speeds, avoid sudden or hard acceleration. Driving aggressively or making abrupt maneuvers even on flat, open areas can cause side rollovers. Avoid sideways sliding, skidding, or fishtailing, and never do donuts. If you feel the Rhino begin to slide sideways or fishtail during a turn, steer into the direction of the slide, if possible, and gradually let off the accelerator pedal to regain directional control and avoid rollover. For example, if you feel the back of the vehicle start to slide to your right, steer to the right.

If you think or feel that the vehicle may tip or roll, keep your body completely inside the protective structure of the vehicle:

- Brace yourself by pressing your feet firmly on the floorboards and keep a firm grip on the steering wheel or handholds.
- Do not put your hands or feet outside of the vehicle for any reason. Do not try to stop a tipover using your arm or leg.



## Accelerating

With the engine idling in neutral and your foot on the brake, shift the drive select lever into low or high. **NOTICE: Do not shift from low to high or vice versa without coming to a complete stop and waiting for the engine to return to normal idle speed – damage to the engine or drive train may occur. Then release the parking brake.** Press the accelerator pedal slowly and smoothly. The centrifugal clutch will engage and the vehicle will begin to accelerate.

Avoid higher speeds and sudden or hard acceleration until you are thoroughly familiar with the operation of your vehicle. Avoid sudden or hard acceleration in any turn.

## Braking

When slowing down or stopping, take your foot off the accelerator pedal and press the brake pedal smoothly. Improper use of the brakes can cause the tires to lose traction, reducing control of the vehicle and increasing the possibility of an accident.

Braking ability is affected by type of terrain. In most cases, gradual application of the brakes is more effective than abrupt braking, particularly on loose surfaces, such as gravel. Always allow for greater braking distance on rough, loose, or slippery surfaces.

## Engine braking

Engine compression braking is designed to assist you when operating your Rhino off-road. With this feature, the engine helps slow the vehicle down after you take your foot off the accelerator. Engine braking is more noticeable in 4WD. Application of vehicle brakes provides additional stopping power.

## **Leaving the vehicle**

Do not get out of the vehicle while the engine is running and the drive select lever is in any gear. There is a risk of injury because:

- Children or others may accidentally press the accelerator pedal.
- Objects tossed into the vehicle may strike the accelerator pedal.
- The parking brake may not keep the vehicle from accelerating.

Unwanted vehicle movement can cause serious injury or death, and it may be dangerous to try to stop the vehicle.

## **Parking on a flat area**

When parking on a flat area, stop the engine and shift the drive select lever into the neutral position. Apply the parking brake to help prevent the vehicle from rolling.

## **Parking on a slope**

The parking brake acts only on the rear wheels when in 2WD. For the parking brake to take effect on all four wheels, shift to 4WD Diff. Lock before stopping the engine.

If you park on a hill that is too steep the vehicle may roll out of control. Never park on hills that are so steep you cannot walk up them easily. If you must park on an incline follow these instructions:

1. Bring the vehicle to a stop by applying the brakes.
2. Put the vehicle in 4WD Diff. Lock.
3. Turn the engine off.

4. With the brake pedal applied, set the parking brake.
5. Block the front and rear wheels with rocks or other objects.

### **Loading**

The total weight of operator, passenger, accessories, cargo, trailer tongue weight, and the vehicle itself must not exceed 907 kg (2,000 lb). Vehicle loading can affect handling. See “Loading” on pages 6-9–6-11.

### **Operation on different surfaces and terrains**

Go slowly and proceed with caution when operating on an unfamiliar surface or terrain. This vehicle may handle differently in certain types of terrains or on certain surfaces. You may come upon hidden rocks, bumps, or holes without enough time to react. To avoid loss of control or rollover, always be alert to changing surfaces or terrain when operating the vehicle.

The Rhino has higher ground clearance and other features to handle rugged terrain, and as a result, can overturn in situations where some vehicles may not. Abrupt maneuvers or aggressive driving can cause loss of control, including rollovers – even on flat, open areas. These rollovers can result in crushed limbs and other serious injuries or death to drivers or passengers.

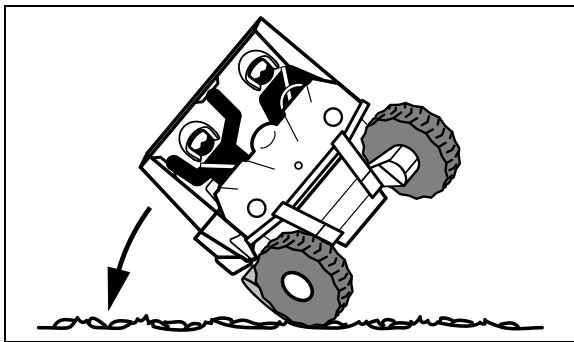

## Hills

Choose carefully which hills you attempt to climb or descend. Avoid hills with slippery surfaces or those where you will not be able to see far enough ahead of you. Use common sense and remember that some hills are too steep for you to climb or descend. Use proper driving techniques to avoid rearward, forward, or sideways rollovers on hills and slopes.

Drive straight up and down inclines, not across them. If crossing a hill is unavoidable, drive slowly. Turn downhill immediately if you feel the vehicle may tip.

### **If you think or feel the Rhino may tip or roll:**

- Brace yourself by pressing your feet firmly on the floorboards and keep a firm grip on the steering wheel or handholds.
- Do not put your hands or feet outside of the vehicle for any reason.

## **Uphill**

Do not attempt to climb hills until you have mastered basic maneuvers on flat ground. Drive straight up hills, and avoid crossing the side of a hill, which increases your risk of roll-over. Practice first on gentle slopes before attempting steeper hills. Always check the terrain carefully before attempting any hill.

To climb a hill, you need traction, momentum, and steady throttle. For more traction and control for climbing steeper and/or rougher slopes, shift into low gear and select 4WD or 4WD Diff. Lock. Travel fast enough to maintain momentum, but not so fast that you cannot react to changes in the terrain as you climb.

Slow down when you reach the crest of the hill if you cannot see clearly what is on the other side – there could be another person, an obstacle, or a sharp drop-off.

If you start to lose traction or momentum when climbing, and decide you will be unable to continue, use the brakes to stop. Do not attempt to turn the vehicle around. With your foot on the brake pedal, look behind you and plan your descent. Shift the drive select lever into reverse so you can use engine braking to slow your descent. Release the brake and begin to coast down the hill. Use engine braking as much as possible, gently applying the brakes when necessary.

## **Downhill**

Check the terrain carefully before going downhill. When possible, choose a path that lets you drive your vehicle straight downhill. Choose your path carefully and drive slowly enough to be able to react to obstacles that you encounter.

For more traction and control, before going down steeper and/or rougher slopes, shift into low gear and select 4WD or 4WD Diff. Lock. Engine braking will help you go downhill slowly. Go as slowly as possible. If you begin to go too fast, apply the brakes gently. Avoid hard application of the brakes, which could cause the vehicle to slide.

If you are sliding or skidding, try to steer in the direction the vehicle is sliding, to regain control. For example, if you feel the back of the vehicle start to slide to your right, steer to the right.

If you must turn on the hill to avoid an obstacle, do so slowly and carefully. If the vehicle starts to tip, immediately steer in the downhill direction if there are no obstacles in your path. As you regain proper balance, gradually steer again in the direction you want to go.

## **Rough terrain**

Operation over rough terrain should be done with caution.

- Look for and avoid obstacles that could cause damage to the vehicle or could lead to a rollover or accident.
- Do not drive in a way that will get the Rhino airborne, as injury, loss of control, and damage to the vehicle could occur.

## **Pavement**

This vehicle is designed for off-road use only. Avoid paved surfaces. Turn gradually and go slowly if you must drive on pavement.

## **Water**

If you must cross shallow, slow-moving water up to the depth of the vehicle's floorboards, choose your path carefully to avoid sharp drop-offs, large rocks, or slippery surfaces that could cause the vehicle to overturn. Never operate through water deeper than 33 cm (13 in) or fast-flowing water. Choose a path where both your entrance into and exit point from the water is a gradual incline. Determine the water depth and currents before crossing.

Operating this vehicle through deep or fast-flowing water can lead to loss of control or overturn. To reduce your risk of drowning or other injuries, use care when crossing through water.

Wet brakes may have reduced effectiveness. After leaving the water, test your brakes. If necessary, apply the brakes several times to let friction dry out the linings.

## ***NOTICE***

**After driving your vehicle in water, be sure to drain the trapped water by removing the check hose at the bottom of the air filter case, the V-belt cooling duct check hose, the drive select lever box check hose and the V-belt case drain plug. Wash the vehicle in fresh water if it has been operated in salt water or muddy conditions.**

## **Loose terrain/slippery terrain**

When driving on slippery terrain, including wet, muddy, or icy conditions, as well as loose gravel, be aware that you could begin skidding or sliding. To avoid loss of control, slow down and put the Rhino in 4WD before driving on a slippery surface and plan your path to avoid making abrupt maneuvers.

If you feel the Rhino begin to slide sideways or fishtail during a turn, steer into the direction of the slide if possible, to regain directional control. For example, if you feel the back of the vehicle start to slide to your right, steer to the right.



## **Brush or wooded areas**

When operating in areas with brush or trees, watch carefully on both sides and above the vehicle for obstacles such as branches that the vehicle might hit, causing an accident. Watch for brush that might enter the vehicle as you pass and strike you or the passenger. Never hold onto the cage/frame. The passenger should always hold onto the handholds with both hands.

The muffler and other engine parts become extremely hot during operation and remain hot after the engine has stopped. To reduce the risk of fire during operation or after leaving the vehicle, do not let brush, grass and other materials collect under the vehicle, near the muffler or exhaust pipe, or next to other hot parts. Check under the vehicle after operating in areas where combustible materials may have collected. Do not idle or park the vehicle in long dry grass or other dry ground cover.

## **Encountering obstacles**

If you cannot go around an obstacle, such as a fallen tree or a ditch, stop the vehicle where it is safe to do so. Set the parking brake and get out to inspect the area thoroughly. Look from both your approach side and exit side. If you believe you can continue safely, choose the path that will allow you to get over the obstacle and at as close to a right angle as possible to minimize vehicle tipping. Go only fast enough to maintain your momentum but still give yourself plenty of time to react to changes in conditions.

If there is any question about your ability to maneuver safely over the obstacle, you should turn around if the ground is flat and you have the room or back up until you find a less difficult path.

## PERIODIC MAINTENANCE AND ADJUSTMENT

Periodic inspection, adjustment, and lubrication will keep your vehicle in the safest and most efficient condition possible.

Safety is an obligation of the vehicle owner/operator. The most important points of vehicle inspection, adjustment, and lubrication are explained on the following pages.

### **WARNING**

---

**Failure to properly maintain the vehicle or performing maintenance activities incorrectly may increase your risk of injury or death during service or while using the vehicle. If you are not familiar with vehicle service, have a Yamaha dealer perform service.**

---

### **WARNING**

---

**Turn off the engine when performing maintenance unless otherwise specified.**

- **A running engine has moving parts that can catch on body parts or clothing and electrical parts that can cause shocks or fires.**
  - **Running the engine while servicing can lead to eye injury, burns, fire, or carbon monoxide poisoning – possibly leading to death. See page 2-8 for more information about carbon monoxide.**
-

## Owner's manual and tool kit

You are recommended to put this owner's manual in the vinyl bag and always carry it underneath the driver seat as shown. Put the owner's tool kit and tire pressure gauge in the space beside the battery.

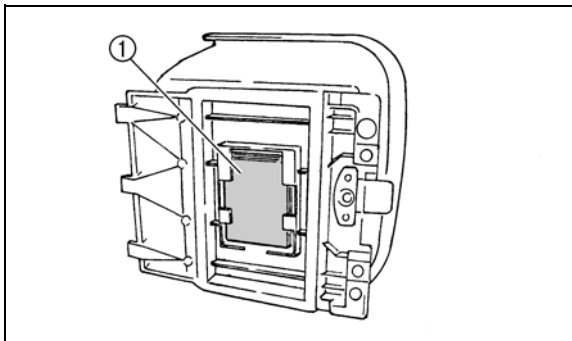

1. Owner's manual

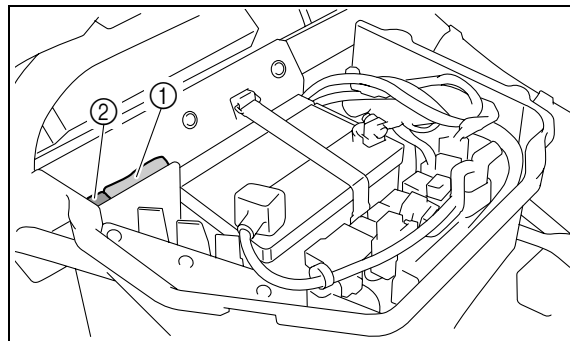

1. Owner's tool kit

2. Tire pressure gauge

The service information included in this manual is intended to provide you, the owner, with the necessary information for completing your own preventive maintenance and minor repairs.

The tools provided in the owner's tool kit are sufficient for this purpose, except that a torque wrench is also necessary to properly tighten nuts and bolts.

If you do not have a torque wrench available during a service operation requiring one, take your vehicle to a Yamaha dealer to check the torque settings and adjust them as necessary.

## Periodic maintenance chart for the emission control system

- For vehicles not equipped with an odometer or hour meter, follow the month maintenance intervals.
- For vehicles equipped with an odometer or an hour meter, follow the km (mi) or hours maintenance intervals. However, keep in mind that if the vehicle isn't used for a long period of time, the month maintenance intervals should be followed.
- Items marked with an asterisk should be performed by a Yamaha dealer as they require special tools, data and technical skills.

ITEM	ROUTINE	Whichever comes first ⇒	INITIAL			EVERY		
			month	1	3	6	6	12
			km (mi)	320 (200)	1,200 (750)	2,400 (1,500)	2,400 (1,500)	4,800 (3,000)
hours	20	75	150	150	300			
Fuel line*	<ul style="list-style-type: none"> <li>• Check fuel hose for cracks or damage.</li> <li>• Replace if necessary.</li> </ul>				○	○	○	
Valves*	<ul style="list-style-type: none"> <li>• Check valve clearance.</li> <li>• Adjust if necessary.</li> </ul>		○		○	○	○	
Spark plug	<ul style="list-style-type: none"> <li>• Check condition.</li> <li>• Adjust gap and clean.</li> <li>• Replace if necessary.</li> </ul>		○	○	○	○	○	
Crankcase breather system*	<ul style="list-style-type: none"> <li>• Check breather hose for cracks or damage.</li> <li>• Replace if necessary.</li> </ul>				○	○	○	
Exhaust system*	<ul style="list-style-type: none"> <li>• Check for leakage.</li> <li>• Tighten if necessary.</li> <li>• Replace gasket(s) if necessary.</li> </ul>				○	○	○	
Spark arrester	<ul style="list-style-type: none"> <li>• Clean.</li> </ul>				○	○	○	

## General maintenance and lubrication chart

ITEM	ROUTINE	Whichever comes first ⇒	INITIAL			EVERY		
			month	1	3	6	6	12
			km (mi)	320 (200)	1,200 (750)	2,400 (1,500)	2,400 (1,500)	4,800 (3,000)
hours	20	75	150	150	300			
<b>Cooling system</b>	<ul style="list-style-type: none"> <li>• Check coolant leakage.</li> <li>• Repair if necessary.</li> <li>• Replace coolant every 24 months.</li> </ul>		○	○	○	○	○	
<b>Air filter element</b>	<ul style="list-style-type: none"> <li>• Clean.</li> <li>• Replace if necessary.</li> </ul>		Every 20–40 hours (More often in wet or dusty areas.)					
<b>Engine oil</b>	<ul style="list-style-type: none"> <li>• Replace (warm engine before draining).</li> </ul>		○		○	○	○	
<b>Engine oil filter cartridge</b>	<ul style="list-style-type: none"> <li>• Replace.</li> </ul>		○		○		○	
<b>Final gear oil</b>	<ul style="list-style-type: none"> <li>• Check oil level/oil leakage.</li> </ul>		○				○	
<b>Differential gear oil</b>	<ul style="list-style-type: none"> <li>• Replace.</li> </ul>		○				○	
<b>Front brake*</b>	<ul style="list-style-type: none"> <li>• Check operation/brake pad wear/fluid leakage/see page 8-6.</li> <li>• Correct if necessary. Replace pads if worn to the limit.</li> </ul>		○	○	○	○	○	
<b>Rear brake*</b>	<ul style="list-style-type: none"> <li>• Check operation/brake pad wear/fluid leakage/see page 8-6.</li> <li>• Correct if necessary. Replace pads if worn to the limit.</li> </ul>		○	○	○	○	○	
<b>Parking brake*</b>	<ul style="list-style-type: none"> <li>• Check operation and free play/brake pad wear.</li> <li>• Correct if necessary. Replace pads if worn to the limit.</li> </ul>		○	○	○	○	○	
<b>Accelerator pedal*</b>	<ul style="list-style-type: none"> <li>• Check operation and free play.</li> </ul>		○	○	○	○	○	
<b>V-belt*</b>	<ul style="list-style-type: none"> <li>• Check operation.</li> <li>• Check for wear, cracks, or damage.</li> </ul>		○			○	○	
<b>Wheels*</b>	<ul style="list-style-type: none"> <li>• Check balance/damage/runout.</li> <li>• Repair if necessary.</li> </ul>		○		○	○	○	
<b>Wheel bearings*</b>	<ul style="list-style-type: none"> <li>• Check bearing assemblies for looseness/damage.</li> <li>• Replace if damaged.</li> </ul>		○		○	○	○	
<b>Front and rear suspension*</b>	<ul style="list-style-type: none"> <li>• Check operation and for leakage.</li> <li>• Correct if necessary.</li> </ul>				○		○	
<b>Steering system*</b>	<ul style="list-style-type: none"> <li>• Check operation and for looseness/Replace if damaged.</li> <li>• Check toe-in/Adjust if necessary.</li> </ul>		○	○	○	○	○	
<b>Rear upper and lower knuckle pivots*</b>	<ul style="list-style-type: none"> <li>• Lubricate with lithium-soap-based grease.</li> </ul>				○	○	○	

ITEM	ROUTINE	Whichever comes first ⇒	INITIAL			EVERY		
			month	1	3	6	6	12
			km (mi)	320 (200)	1,200 (750)	2,400 (1,500)	2,400 (1,500)	4,800 (3,000)
			hours	20	75	150	150	300
Drive shaft universal joint*	• Lubricate with lithium-soap-based grease.			○	○	○		
Engine mount*	• Check for cracks or damage. • Check bolt tightness.			○	○	○		
Front and rear axle boots*	• Check operation. • Replace if damaged.	○				○		
Stabilizer bushings*	• Check for cracks or damage.			○	○	○		
Fittings and fasteners*	• Check all chassis fittings and fasteners. • Correct if necessary.	○	○	○	○	○		

## Recommended brake fluid: DOT 4

### Brake fluid replacement:

- Replace the brake fluid when disassembling the master cylinder or caliper.
- Check the brake fluid level regularly and add fluid as required.
- Replace the oil seals on the inner parts of the master cylinder and caliper every two years.
- Replace the brake hoses every four years, or if cracked or damaged.

## Hood

### To open

Unhook the hood latches, and then slowly tilt the hood up until it stops.

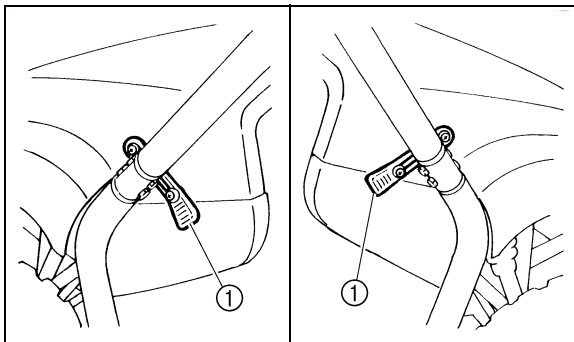

1. Latch (x 2)

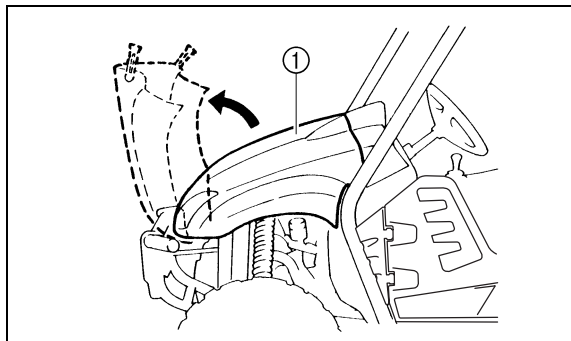

1. Hood



## To close

Lower the hood slowly to its original position, and then hook the hood latches. Secure projections ① on the rear of the hood into slots ② on the back of the instrument panel. Secure slots ③ on the side of the hood around projections ④ on the frame.

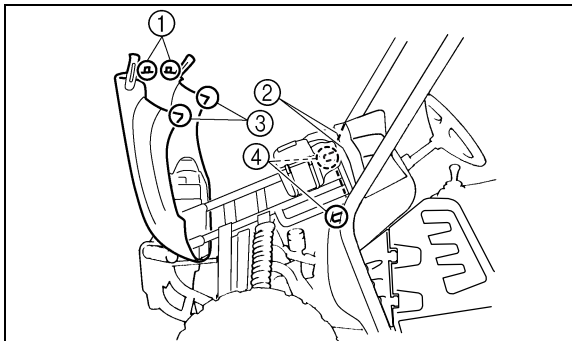

1. Projection (× 2)

2. Slot (× 2)

3. Slot (× 2)

4. Projection (× 2)

## NOTICE

- Make sure that all cables and wires are in place when closing the hood.
- Do not drive the vehicle with the hood open, unlatched, or removed.

## Console

### To remove

1. Remove the seats. (See pages 4-16–4-17 for seat removal and installation procedures.)
2. Remove the parking brake lever boot.
3. Pull the console forward and upward (the drive select lever boot will come loose). To ease removal of the console, shift the drive select lever into the low gear “L” position.

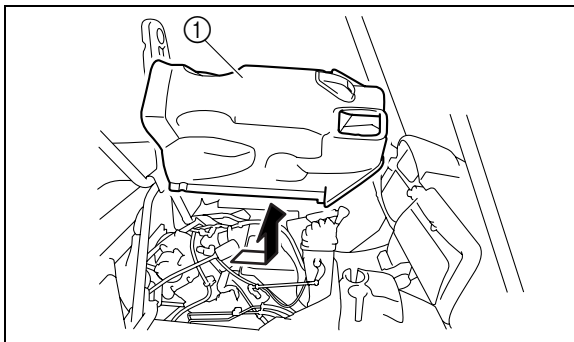

1. Console

### To install

1. Place the console in its original position.
2. Install the parking brake lever boot.
3. Install the seats.

### NOTICE

- Be sure to position the seat belt buckles to the outside of the console.
- When installing the console, be sure not to pinch the cables or wires.
- Make sure that the groove at the bottom of the parking brake lever boot and the drive select lever boot fits securely around the edge of the hole in the console.

## Engine oil and oil filter cartridge

Check engine oil level before each operation. In addition, change the oil and the oil filter cartridge at the intervals specified in the periodic maintenance and lubrication chart.

### To check the engine oil level

1. Park the vehicle on a level surface.
2. Remove the console. (See page 8-9 for console removal and installation procedures.)
3. Check the engine oil level on a cold engine. If the engine was started before checking the oil level, be sure to warm up the engine sufficiently, and then wait at least ten minutes until the oil settles for an accurate reading.
4. Remove the dipstick, and then wipe it off with a clean rag.

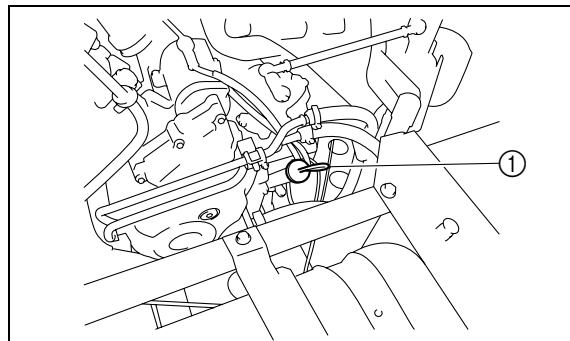

1. Dipstick

5. Insert the dipstick completely into the oil filler hole, and then remove it again to check the oil level. The engine oil should be between the minimum and maximum level marks.

7. Insert the dipstick completely into the oil filler hole.
8. Reinstall the console.

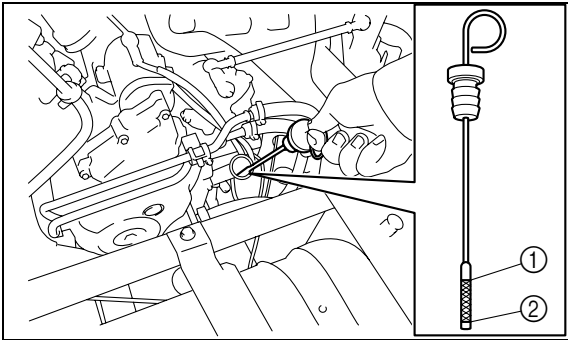

1. Maximum level mark      2. Minimum level mark

6. If the engine oil is at or below the minimum level mark, add sufficient oil of the recommended type to raise it to the correct level.

## To change the engine oil (with or without oil filter cartridge replacement)

1. Park the vehicle on a level surface.
2. Remove the console. (See page 8-9 for console removal and installation procedures.)
3. Start the engine, warm it up for several minutes, and then turn it off.
4. Place an oil pan under the engine to collect the used oil, and then remove the dipstick.
5. Remove the engine oil drain bolt to drain the oil from the crankcase.

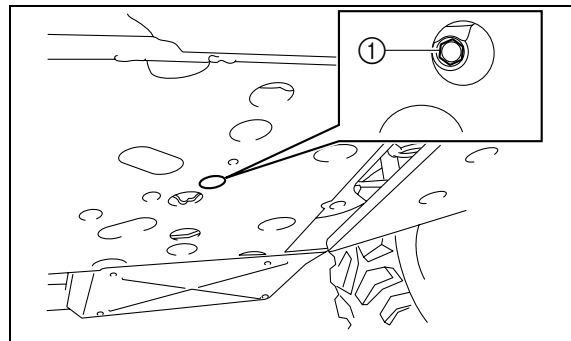

1. Engine oil drain bolt

Skip steps 6–10 if the oil filter cartridge is not being replaced.

6. Lift the cargo bed up. (See pages 4-20–4-21 for cargo bed lifting and lowering procedures.)

7. Remove the oil filter cartridge with an oil filter wrench. An oil filter wrench is available from a Yamaha dealer. Make sure that the O-ring is removed together with the oil filter cartridge. If the O-ring remains attached to the crankcase, oil leakage may occur.

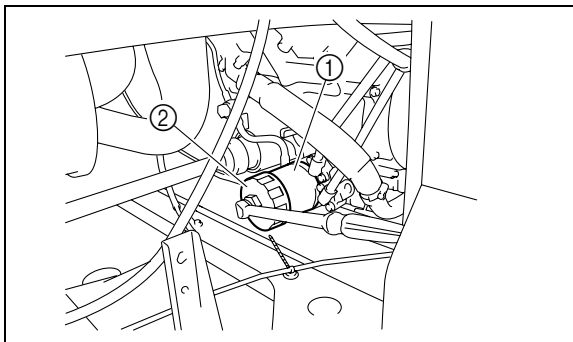

1. Oil filter cartridge      2. Oil filter wrench

8. Apply a light coat of clean engine oil to the O-ring of the new oil filter cartridge. Make sure the O-ring is seated properly.

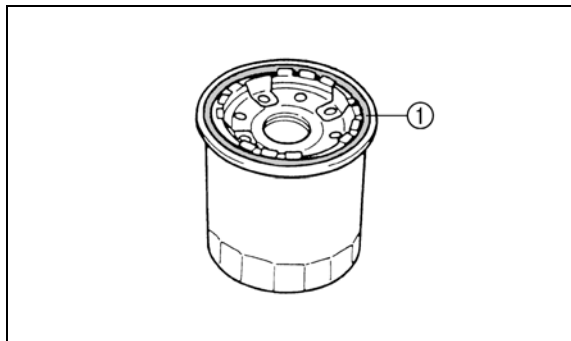

1. O-ring

9. Install the new oil filter cartridge with an oil filter wrench, and then tighten it to the specified torque with a torque wrench.

Tightening torque:

Oil filter cartridge:

17 Nm (1.7 m·kgf, 12 ft·lbf)

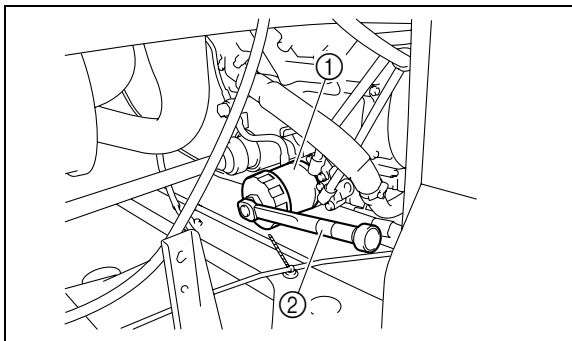

1. Oil filter cartridge      2. Torque wrench
10. Lower the cargo bed.
11. Reinstall the engine oil drain bolt, and then tighten it to the specified torque.

**Tightening torque:**

Engine oil drain bolt:

30 Nm (3.0 m·kgf, 22 ft·lbf)

12. Refill with the specified amount of recommended engine oil, and then insert the dipstick completely into the oil filler hole.  
**NOTICE: Be sure to wipe off spilled oil on any parts after the engine and exhaust system have cooled down.**

Recommended engine oil:

See page 10-2.

Oil quantity:

Without oil filter cartridge replacement:

2.00 L (1.76 Imp qt, 2.11 US qt)

With oil filter cartridge replacement:

2.10 L (1.85 Imp qt, 2.22 US qt)

## **NOTICE**

- In order to prevent clutch slippage (since the engine oil also lubricates the clutch), do not mix any chemical additives with oil. Do not use oils with a diesel specification of “CD” or oils of a higher quality than specified. In addition, do not use oils labeled “ENERGY CONSERVING II” or higher.
- Make sure that no foreign material enters the crankcase.

13. Start the engine, and then let it idle for several minutes while checking it for oil leakage. If oil is leaking, immediately turn the engine off and check for the cause.
14. Turn the engine off, wait at least ten minutes, and then check the oil level and correct it if necessary.
15. Reinstall the console.

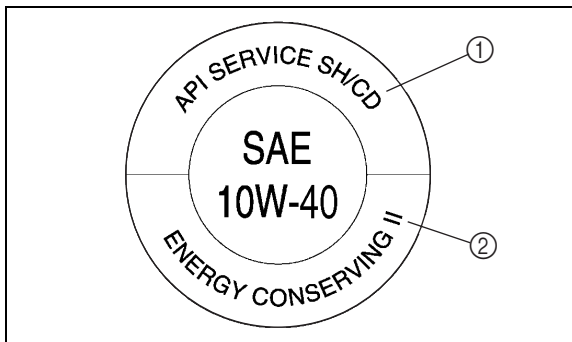

1. “CD” specification
2. “ENERGY CONSERVING II”



## Final gear oil

### Checking the final gear oil level

1. Park the vehicle on a level surface.
2. Remove the oil filler bolt, and then check the oil level in the final gear case. The oil level should be at the brim of the filler hole.

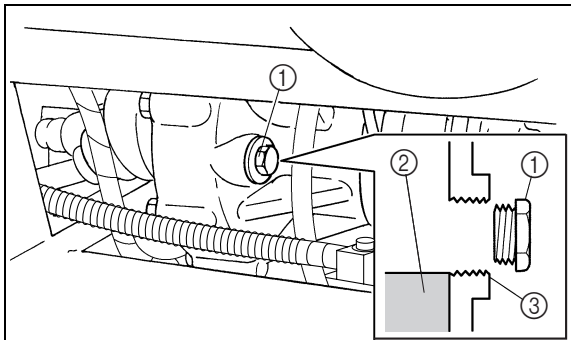

1. Final gear oil filler bolt
2. Final gear oil
3. Correct oil level

3. If the oil is below the brim of the filler hole, add sufficient oil of the recommended type to raise it to the correct level.  
**NOTICE: Be sure no foreign material enters the final gear case.**
4. Reinstall the oil filler bolt, and then tighten it to the specified torque.

Tightening torque:

Final gear oil filler bolt:

23 Nm (2.3 m·kgf, 17 ft·lbf)

## Changing the final gear oil

1. Park the vehicle on a level surface.
2. Remove the final gear case guard by removing the bolts and the collars.

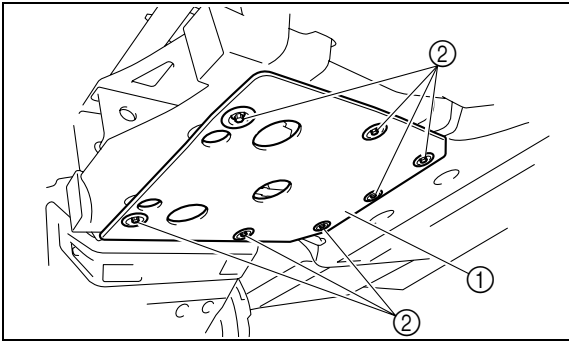

1. Final gear case guard      2. Bolt and collar (× 7)

3. Place a container under the final gear case to collect the used oil.
4. Remove the oil filler bolt and the drain bolt to drain the oil.

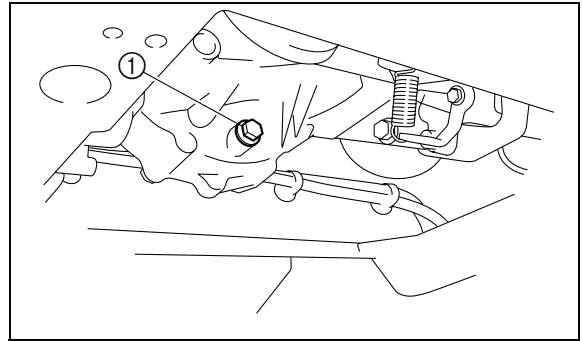

1. Final gear oil drain bolt

5. Reinstall the drain bolt, and then tighten it to the specified torque.

Tightening torque:

Final gear oil drain bolt:

20 Nm (2.0 m·kgf, 14 ft·lbf)

6. Refill with the recommended final gear oil up to the brim of the filler hole. **NOTICE:** **Be sure no foreign material enters the final gear case.**

Recommended oil:

SAE 80 API GL-4 Hypoid gear oil

Oil quantity:

0.25 L (0.22 Imp qt, 0.26 US qt)

7. Reinstall the oil filler bolt, and then tighten it to the specified torque.

Tightening torque:

Final gear oil filler bolt:

23 Nm (2.3 m·kgf, 17 ft·lbf)

8. Check for oil leakage. If oil leakage is found, check for the cause.

9. Install the final gear case guard by installing the bolts and the collars, and then tightening the bolts to the specified torque.

Tightening torque:

Final gear case guard bolt:

7 Nm (0.7 m·kgf, 5.1 ft·lbf)

## Differential gear oil

### Checking the differential gear oil level

1. Park the vehicle on a level surface.
2. Remove the differential gear oil filler bolt and check the oil level. It should be up to the brim of the filler hole. If the level is low, add sufficient oil of the recommended type to raise it to the specified level.  
**NOTICE: Be sure no foreign material enters the differential gear case.**

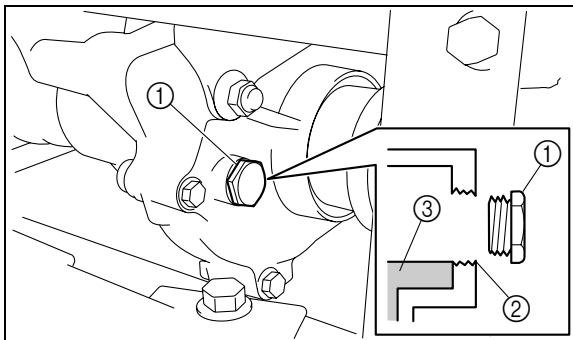

1. Differential gear oil filler bolt
2. Correct oil level
3. Differential gear oil

3. Reinstall the differential gear oil filler bolt, and then tighten it to the specified torque.

Tightening torque:

Differential gear oil filler bolt:  
23 Nm (2.3 m·kgf, 17 ft·lbf)

### Changing the differential gear oil

1. Park the vehicle on a level surface.
2. Remove the differential gear case guard by removing the bolts and the collars.

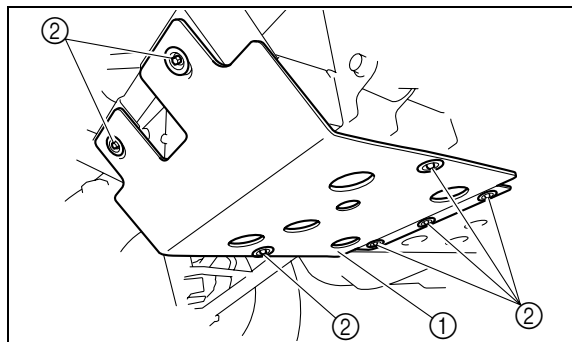

1. Differential gear case guard
2. Bolt and collar (× 7)

3. Place a container under the differential gear case to collect the used oil.
4. Remove the differential gear oil filler bolt and differential gear oil drain bolt to drain the oil.

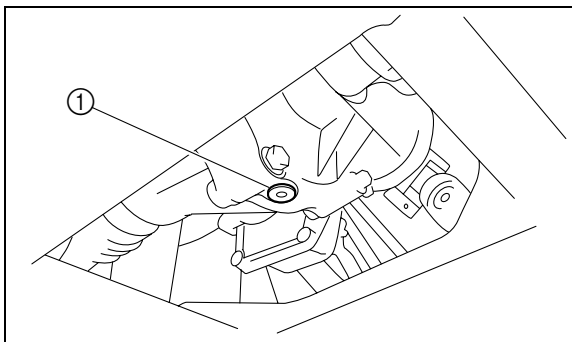

1. Differential gear oil drain bolt

5. Reinstall the differential gear oil drain bolt, and tighten it to the specified torque.

**Tightening torque:**

Differential gear oil drain bolt:

9.8 Nm (0.98 m·kgf, 7.1 ft·lbf)

6. Refill the differential gear case with the recommended oil. **NOTICE: Be sure no foreign material enters the differential gear case.**

Recommended oil:

SAE 80 API GL-4 Hypoid gear oil

Oil quantity:

0.18 L (0.16 Imp qt, 0.19 US qt)

7. Reinstall the differential gear oil filler bolt, and then tighten it to the specified torque.

**Tightening torque:**

Differential gear oil filler bolt:

23 Nm (2.3 m·kgf, 17 ft·lbf)

8. Check for oil leakage. If oil leakage is found, check for the cause.

9. Install the differential gear case guard by installing the bolts and the collars, and then tightening the bolts to the specified torque.

Tightening torque:

Differential gear case guard bolt:  
7 Nm (0.7 m·kgf, 5.1 ft·lbf)

## Coolant

The coolant level should be checked before each ride.

### Checking the coolant level

1. Park the vehicle on a level surface.
2. Check the coolant level in the coolant reservoir when the engine is cold as the coolant level varies with engine temperature. The coolant should be between the minimum and maximum level marks.

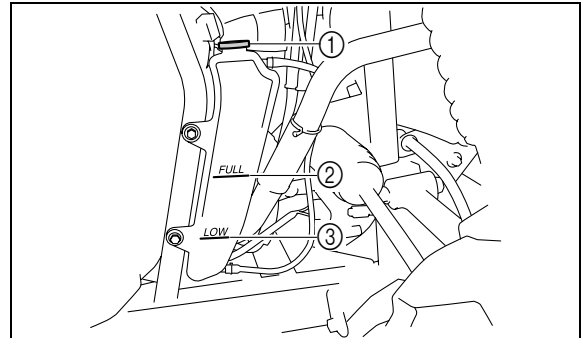

1. Coolant reservoir cap
2. Maximum level mark
3. Minimum level mark

3. If the coolant is at or below the minimum level mark, remove the reservoir cap, add coolant to the maximum level mark, reinstall the reservoir cap.

Coolant reservoir capacity  
(up to the maximum level mark):  
0.32 L (0.28 Imp qt, 0.34 US qt)

### **Changing the coolant**

The coolant must be changed by a Yamaha dealer at the intervals specified in the periodic maintenance and lubrication chart.

Adding water instead of coolant lowers the antifreeze content of the coolant. If water is used instead of coolant, have a Yamaha dealer check the antifreeze content of the coolant as soon as possible.

The radiator fan is automatically switched on or off according to the coolant temperature in the radiator.

### ***NOTICE***

**Mix antifreeze with distilled water only. However, if distilled water is not available, soft water may be used for refilling.**

If your vehicle overheats, see page 8-60 for instructions.

## Axle boots

Check the protective boots for holes or tears. If any damage is found, have them replaced by a Yamaha dealer.

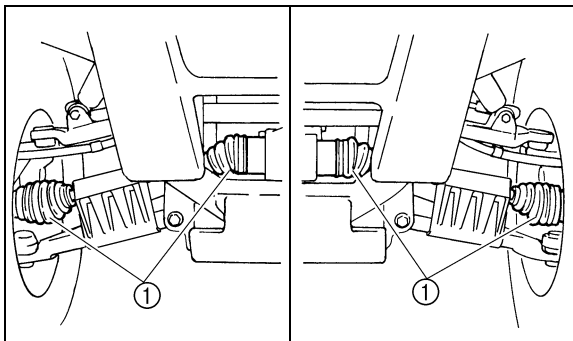

1. Front axle boot (× 2 each side)

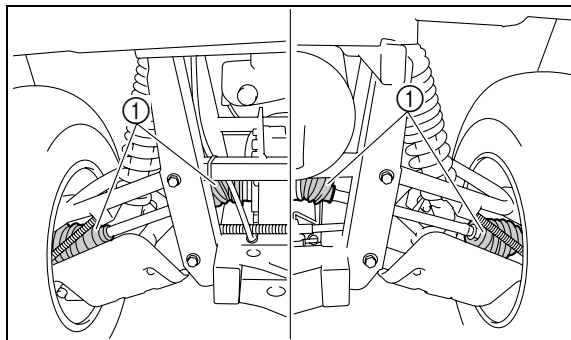

1. Rear axle boot (× 2 each side)



## Spark plug inspection

### Removal

1. Remove the console. (See page 8-9 for console removal and installation procedures.)
2. Remove the spark plug cap.

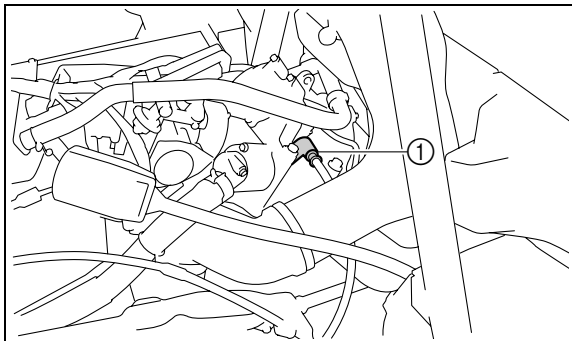

1. Spark plug cap

3. Use the spark plug wrench in the tool kit to remove the spark plug as shown.

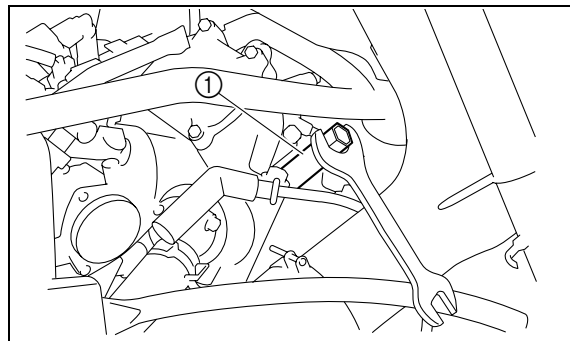

1. Spark plug wrench

## Inspection

The spark plug is an important engine component and is easy to inspect. The condition of the spark plug can indicate the condition of the engine.

The ideal color of the porcelain insulator around the center electrode is a medium-to-light tan for a vehicle that is being ridden normally.

You should periodically remove and inspect the spark plug because heat and deposits will cause the spark plug to slowly break down and erode. If electrode erosion becomes excessive, or if carbon and other deposits are excessive, you should replace the spark plug with the specified plug.

Specified spark plug:  
CPR7EA-9 (NGK)

## Installation

1. Measure the electrode gap with a wire thickness gauge and, if necessary, adjust the gap to specification.

Spark plug gap:  
0.8–0.9 mm (0.031–0.035 in)

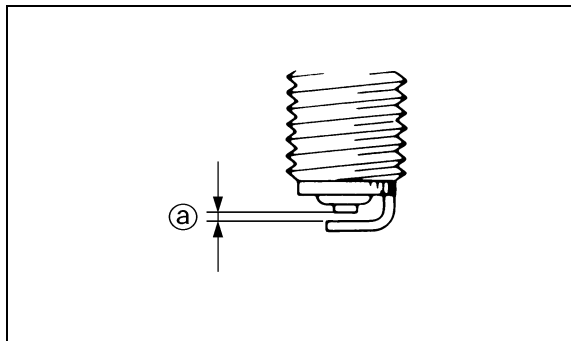

a. Spark plug gap

2. Clean the surface of the spark plug gasket and its mating surface, and then wipe off any grime from the spark plug threads.

3. Install the spark plug and tighten it to the specified torque. If a torque wrench is not available when you are installing the spark plug, a good estimate of the correct torque is one-quarter to one-half turn past finger tight. Have the spark plug tightened to the specified torque as soon as possible.

Tightening torque:

Spark plug:

12.5 Nm (1.25 m·kgf, 9.0 ft·lbf)

4. Install the spark plug cap.
5. Reinstall the console.

### **Cleaning the air filter element**

There is a check hose at the bottom of the air filter case and at the bottom of the air duct under the case. If dust or water collects in a check hose, empty the hose and clean the air filter element and air filter case.

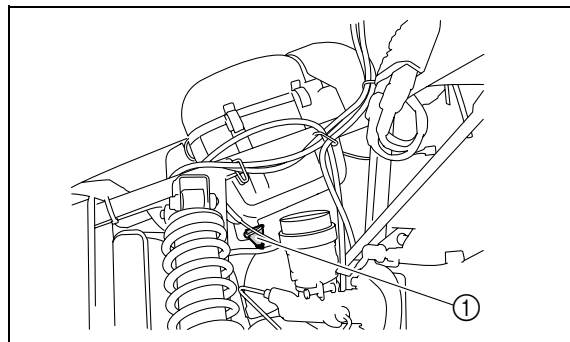

1. Air filter case check hose

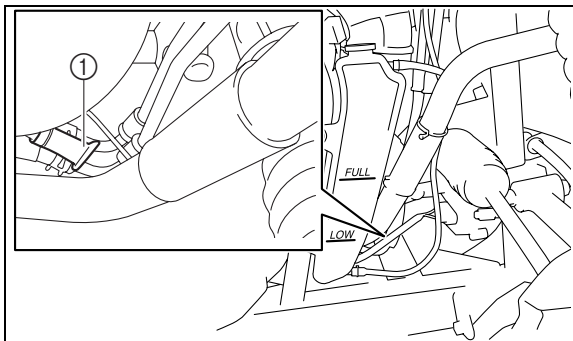

1. Air filter case check hose

1. Open the hood. (See pages 8-7–8-8 for hood opening and closing procedures.)
2. Remove the air intake duct shroud by removing the quick fastener screws.

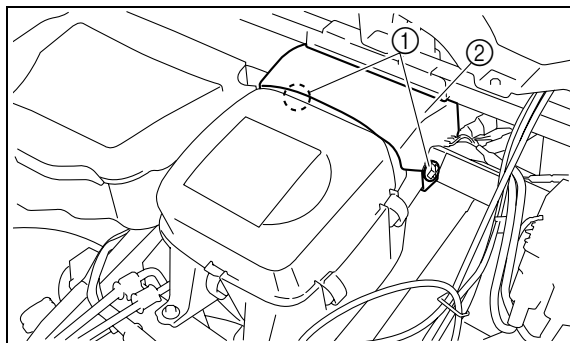

1. Quick fastener screw (× 2)
2. Air intake duct shroud

3. Remove the air filter case cover by unhooking the holders.

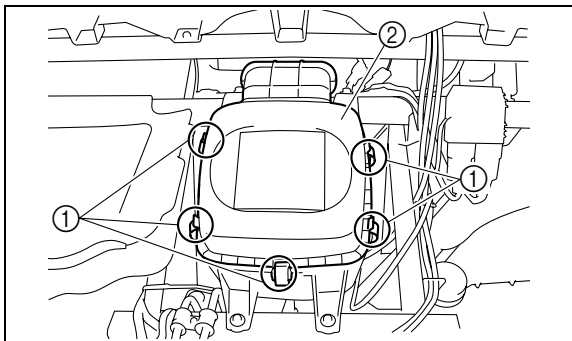

1. Air filter case cover holder (× 5)
2. Air filter case cover

4. Remove the air filter element.

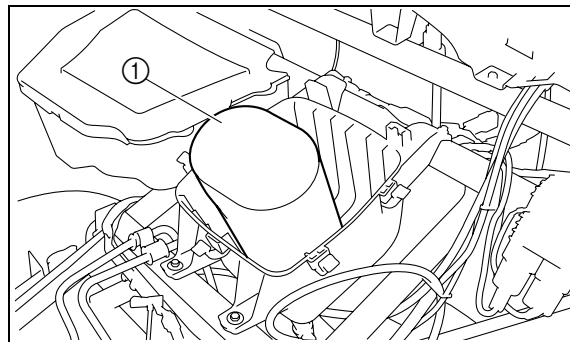

1. Air filter element

5. Remove the sponge material from its frame.

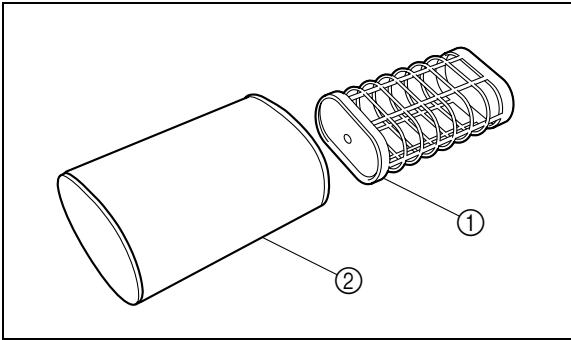

1. Air filter frame

2. Sponge material

6. Wash the sponge material gently but thoroughly in parts cleaning solvent. **WARNING! Using gasoline or other flammable solvents to clean the air filter element can cause a fire or explosion, which could lead to serious injury.**
7. Squeeze the excess solvent out of the sponge material. **NOTICE: Do not twist the sponge material when squeezing it.**

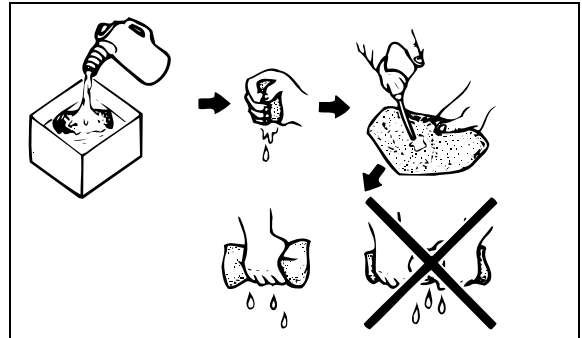

8. Wash the sponge material in warm soapy water to remove remaining solvent, then rinse thoroughly with plain warm water.
9. Squeeze excess water out of the sponge material. **NOTICE: Do not twist the sponge material when squeezing it.**
10. Allow the sponge material to dry thoroughly. Inspect the sponge material and replace it if damaged.
11. Thoroughly apply Yamaha foam air filter oil or other quality liquid foam air filter oil (not spray type) to the sponge material. The sponge material should be wet but not dripping.
12. Pull the sponge material over its frame.
13. Reinstall the air filter element.

14. Insert the projections on the air filter case cover into the holders on the air filter case, and then install the air filter case cover by hooking the holders onto the cover.

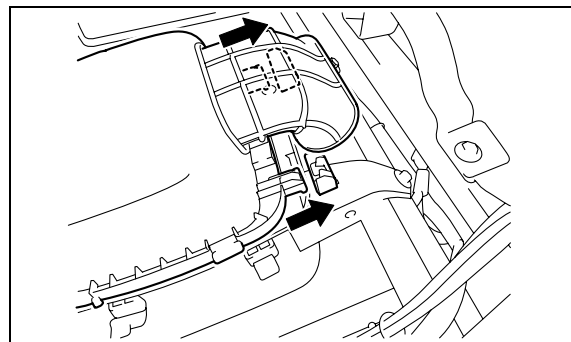

15. Install the air intake duct shroud by installing the quick fastener screws.
16. Close the hood.

The air filter element should be cleaned every 20–40 hours. It should be cleaned and lubricated more often if the vehicle is operated in extremely dusty areas. Each time air filter element maintenance is performed, check the air inlet to the air filter case for obstructions. Check the air filter element rubber joint to the throttle body and manifold fittings for an airtight seal. Tighten all fittings securely to avoid the possibility of unfiltered air entering the engine.

### **NOTICE**

**Never operate the engine with the air filter element removed. This will allow unfiltered air to enter, causing rapid engine wear and possible engine damage. Additionally, operation without the air filter element will affect the fuel injection system with subsequent poor performance and possible engine overheating.**

### **Drive select lever box check hose**

The drive select lever box check hose is located under the console. (See page 8-9 for console removal and installation procedures.) If dust or water collects in the drive select lever box check hose, remove the hose and clean it.

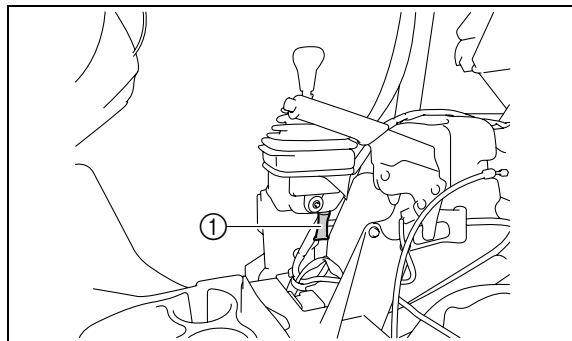

1. Drive select lever box check hose



## V-belt cooling duct check hose

The V-belt cooling duct check hose is located under the cargo bed. If dust or water collects in the V-belt cooling duct check hose, remove the hose and clean it.

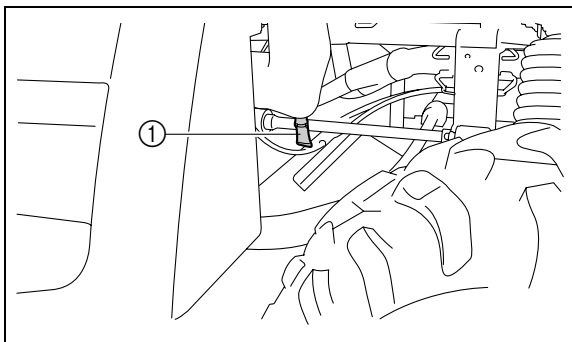

1. V-belt cooling duct check hose

## V-belt case drain plug

The V-belt case drain plug is located under the driver seat. (See pages 4-16–4-17 for seat removal and installation procedures.)

After riding in water deep enough to allow water to enter the V-belt case, remove the drain plug to drain any water from the case.

If water drains from the V-belt case after removing the drain plug, have a Yamaha dealer inspect the vehicle, as the water may affect other engine parts.

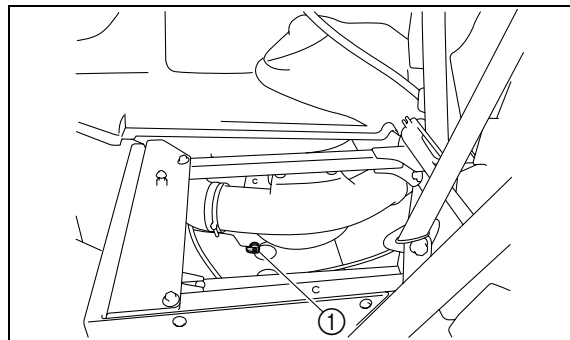

1. V-belt case drain plug

## Cleaning the spark arrester

### **⚠ WARNING**

Hot exhaust system may cause burns. To avoid burns or fires, make sure that the engine is stopped and the exhaust system is cool before cleaning spark arrester. Do not start the engine while cleaning the exhaust system.

1. Remove the bolts.

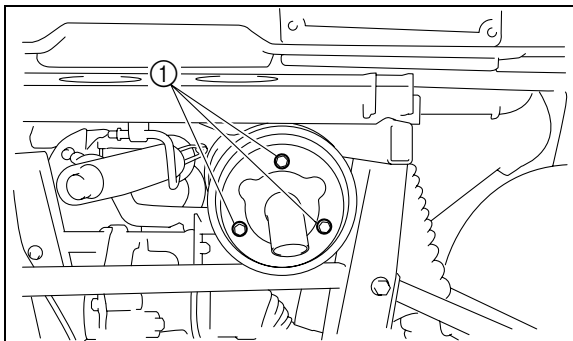

1. Bolt (× 3)

2. Remove the tailpipe by pulling it out of the muffler, and then remove the gasket.
3. Tap the tailpipe lightly, and then use a wire brush to remove any carbon deposits from the spark arrester portion of the tailpipe and inside of the tailpipe housing.

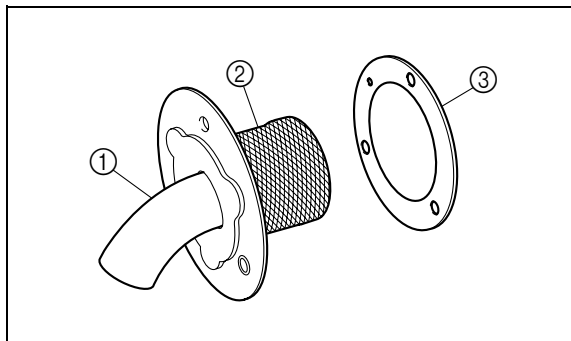

1. Tailpipe
2. Spark arrester
3. Gasket
4. Install the gasket, and then insert the tailpipe into the muffler and align the bolt holes.
5. Install the bolts and tighten them to the specified torque.

Tightening torque:

Tailpipe bolt:

10 Nm (1.0 m·kgf, 7.2 ft·lbf)

### Valve clearance

The correct valve clearance changes with use, resulting in improper fuel/air supply or engine noise. To prevent this, the valve clearance must be adjusted regularly. This adjustment however, should be left to a professional Yamaha service technician.

### Brakes

Replacement of brake components requires professional knowledge. Brake service should be performed by a Yamaha dealer.

### WARNING

**Operating with improperly serviced or adjusted brakes could lead to a loss in braking ability and an accident.**

### Checking the front and rear brake pads

Each brake pad is provided with wear indicator grooves, which allow you to check the brake pad wear without having to disassemble the brake. To check the brake pad wear, check the wear indicator grooves. If a brake pad has worn to the point that the wear indicator grooves have almost disappeared, have a Yamaha dealer replace the brake pads as a set.

The wheels need to be removed to check the brake pads. (See pages 8-43–8-46 for wheel removal and installation procedures.)

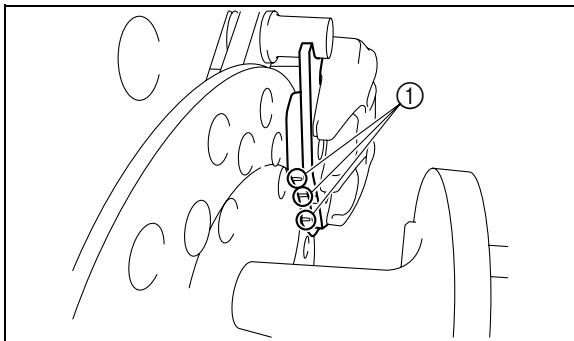

1. Brake pad wear indicator groove

## Checking the parking brake pads

Each brake pad is provided with two wear indicator grooves, which allow you to check the brake pad wear without having to disassemble the brake. To check the brake pad wear, check the wear indicator grooves. If a brake pad has worn to the point that a wear indicator groove almost appears, have a Yamaha dealer replace the brake pads as a set.

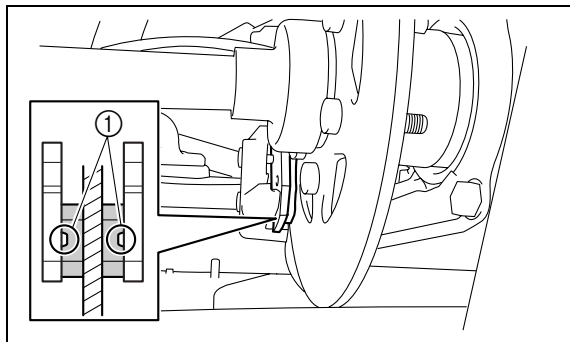

1. Brake pad wear indicator groove

## Checking the brake fluid level

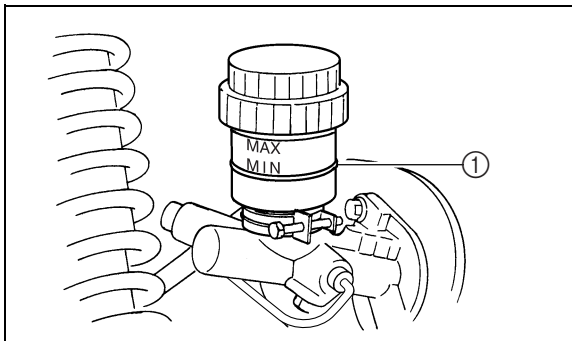

1. Minimum level mark

Insufficient brake fluid may allow air to enter the brake system, possibly causing the brakes to become ineffective.

Before riding, check that the brake fluid is above the minimum level mark and replenish, if necessary. A low brake fluid level may indicate worn brake pads and/or brake system leakage. If the brake fluid level is low, be sure to check the brake pads for wear and the brake system for leakage.

The brake fluid reservoir is located under the hood. (See pages 8-7–8-8 for hood opening and closing procedures.)

Observe these precautions:

- When checking the fluid level, make sure the top of the brake fluid reservoir is level.
- Use only the recommended quality brake fluid. Otherwise, the rubber seals may deteriorate, causing leakage and poor braking performance.

Recommended brake fluid: DOT 4

- Refill with the same type of brake fluid. Mixing fluids may result in a harmful chemical reaction and lead to poor braking performance.
- Be careful that water does not enter the brake fluid reservoir when refilling. Water will significantly lower the boiling point of the fluid and may result in vapor lock.

- Brake fluid may deteriorate painted surfaces or plastic parts. Always clean up spilled fluid immediately.
- Have a Yamaha dealer inspect the brake system if the brake fluid level goes down.

### **Brake fluid replacement**

Complete fluid replacement should be done only by trained Yamaha service personnel. Have a Yamaha dealer replace the following components during periodic maintenance or when they are damaged or leaking.

- Replace the oil seals every two years.
- Replace the brake hoses every four years.

### **Checking the brake pedal**

Have a Yamaha dealer check the brakes at the intervals specified in the periodic maintenance and lubrication chart. There should be no free play in the brake pedal. The brakes should operate smoothly and there should be no brake drag. If the brakes feel soft or spongy, this could indicate air in the brake system. Have a Yamaha dealer check the brake system if necessary.

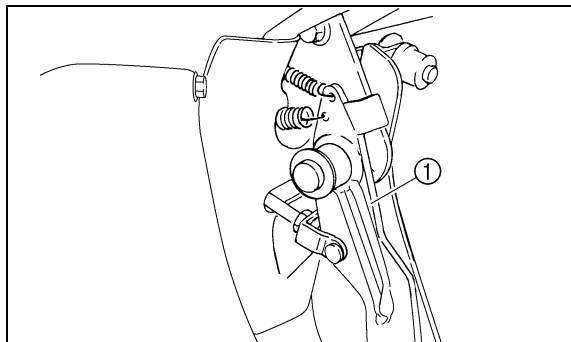

1. Brake pedal

## Parking brake lever free play adjustment

Periodically check the parking brake lever free play and adjust it if necessary.

1. Shift the drive select lever into low gear “L”.
2. Remove the seats. (See pages 4-16–4-17 for seat removal and installation procedures.)
3. Remove the console. (See page 8-9 for console removal and installation procedures.)
4. Check the parking brake lever free play. The maximum free play is equal to one click of the parking brake lever. If necessary, adjust the free play as follows.

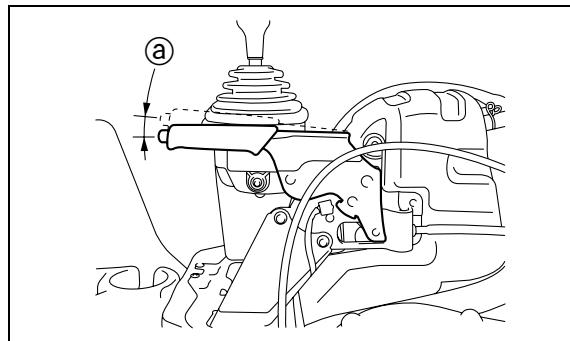

a. Parking brake lever free play

5. The parking brake lever must be released when checking and adjusting the parking brake lever free play.
6. Loosen the locknut.

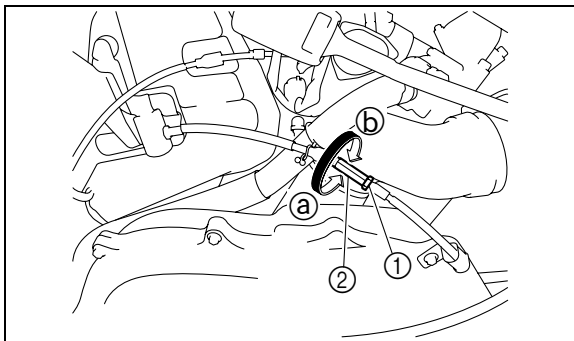

1. Locknut

2. Adjusting nut

7. Turn the adjusting nut in direction **(a)** to increase the free play or in direction **(b)** to decrease the free play.
8. Tighten the locknut.
9. Reinstall the console.
10. Reinstall the seats.

## Brake light switch adjustment

The brake light switch, which is activated by the brake pedal, is properly adjusted when the brake light comes on just before braking takes effect. If necessary, adjust the brake light switch as follows.

1. Open the hood. (See pages 8-7–8-8 for hood opening and closing procedures.)
2. Turn the adjusting nut while holding the brake light switch in place. To make the brake light come on earlier, turn the adjusting nut in direction **(a)**. To make the brake light come on later, turn the adjusting nut in direction **(b)**.
3. Close the hood.



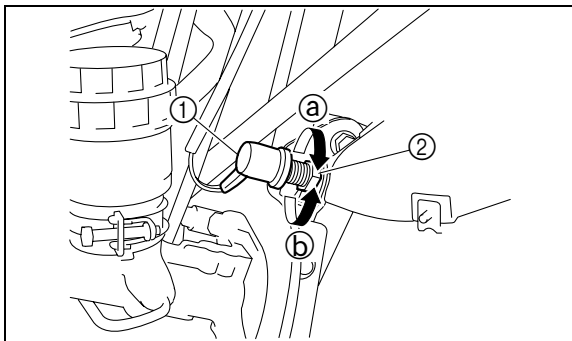

1. Brake light switch

2. Adjusting nut

## Cable inspection and lubrication

### **⚠ WARNING**

**Damaged cables could restrict operation, which may cause an accident or injury. Inspect control cables frequently and replace damaged cables. Corrosion can result when the outer covering of control cables becomes damaged. Cables can also become frayed or kinked.**

Lubricate the cable ends. If the cables do not operate smoothly, ask a Yamaha dealer to replace them.

Recommended lubricant:  
Lithium-soap-based grease

## Brake pedal and accelerator pedal lubrication

Lubricate the pivoting parts.

Recommended lubricant:  
Lithium-soap-based grease

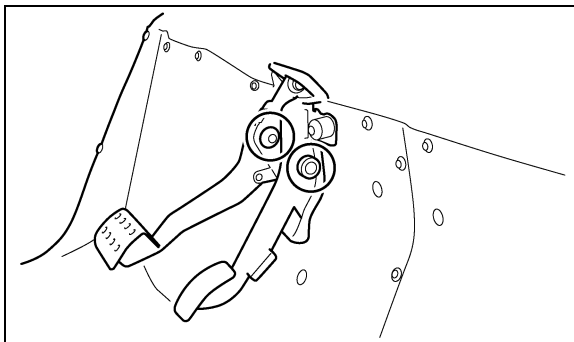

## Rear knuckle upper and lower pivot lubrication

1. Remove the lower arm protector by removing the bolts.

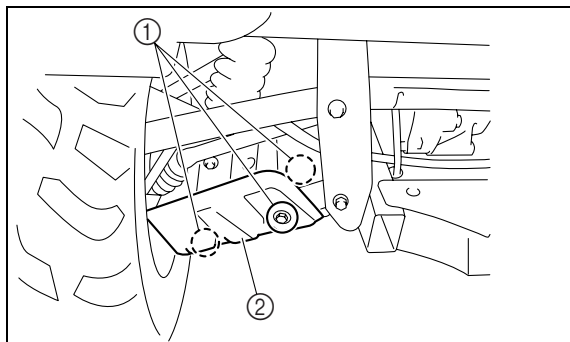

1. Bolt (× 3)

2. Lower arm protector

2. Lubricate the knuckle upper and lower pivots with a grease gun.

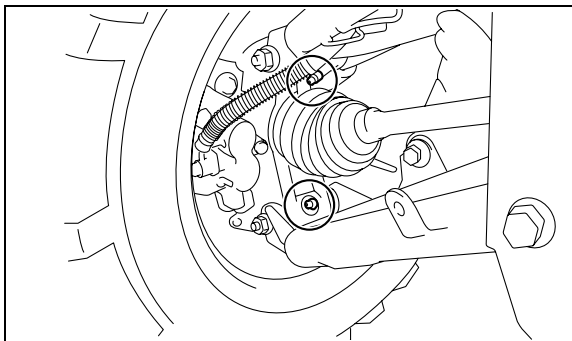

Recommended lubricant:  
Lithium-soap-based grease

3. Install the lower arm protector by installing the bolts and tightening them to the specified torque.

Tightening torque:  
Lower arm protector:  
7 Nm (0.7 m·kgf, 5.1 ft·lbf)

## Steering shaft lubrication

Lubricate the pivot points.

Recommended lubricant:  
Lithium-soap-based grease

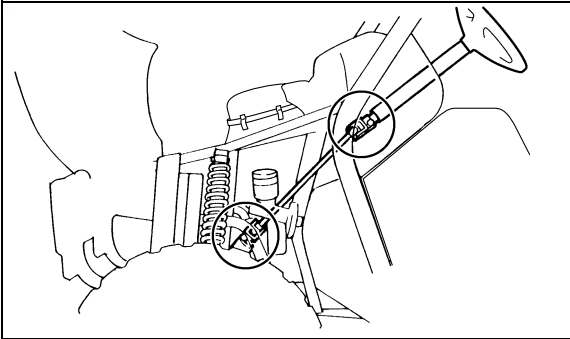

## Wheel removal

1. Loosen the wheel nuts.
2. Elevate the vehicle and place a suitable stand under the frame.
3. Remove the nuts from the wheel.
4. Remove the wheel.

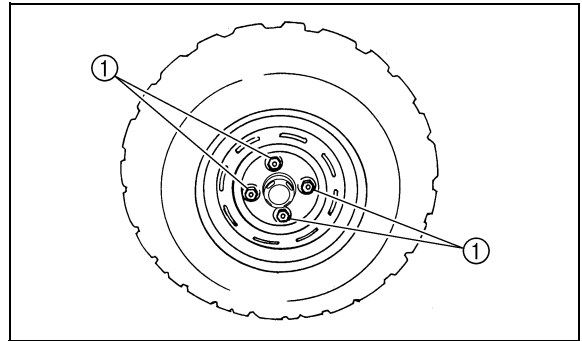

1. Nut (× 4)

## Tire replacement

Always use the same size and type of tires recommended in this owner's manual. The tires that came with your Rhino were designed to match the performance capabilities and to provide the best combination of handling, braking, and comfort. It is best to replace all four tires at the same time. If that is not possible, you must replace the tires in pairs (front or rear) with tires of the same size and type as the originals. Never replace just one tire.

### **WARNING**

**Installing improper tires on your Rhino can affect handling and stability. This can cause a loss of control.**

The tires listed below have been approved by Yamaha Motor Manufacturing Corporation of America for this model.

	Manufacturer	Size	Type
Front	MAXXIS	25 × 8-12NHS	M951Y
Rear	MAXXIS	25 × 10-12NHS	M952Y

## Wheel installation

1. Install the wheel and the nuts.
  - The arrow mark  on the tire must point toward the rotating direction of the wheel.
  - Tapered nuts are used for both the front and rear wheels. Install the nuts with their tapered side towards the wheel.
2. Lower the vehicle so that the wheel is on the ground.
3. Tighten the wheel nuts to the specified torque.

### WARNING

**Do not reverse the rims on the Rhino to widen the track width. Installing wheels improperly increases the risk of wheel failure and accidents.**

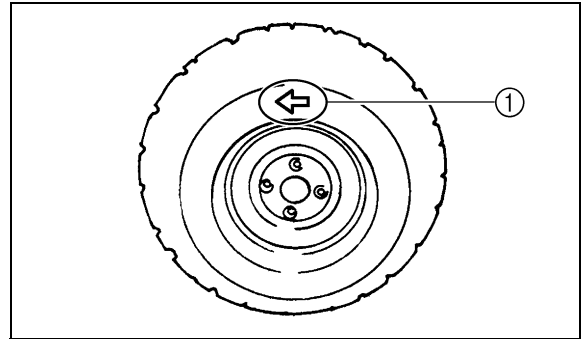

1. Arrow mark

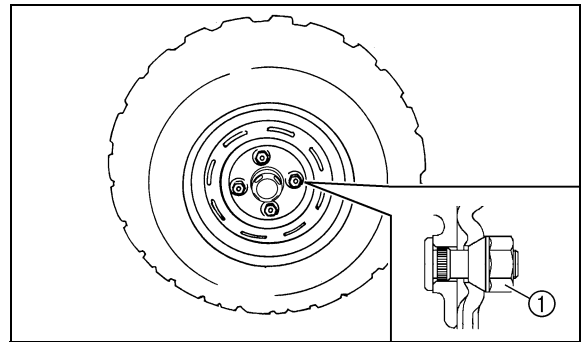

1. Tapered nut

Wheel nut torque:

Front: 55 Nm (5.5 m·kgf, 40 ft·lbf)

Rear: 55 Nm (5.5 m·kgf, 40 ft·lbf)

## **Battery**

This vehicle is equipped with a sealed-type battery. Therefore it is not necessary to check the electrolyte or add distilled water in the battery.

If the battery seems to have discharged, consult a Yamaha dealer.

### ***NOTICE***

**Do not try to remove the sealing caps of the battery cells. You may damage the battery.**

** WARNING**

**Avoid battery contact with skin, eyes, or clothing. Shield eyes when working near batteries. Keep out of reach of children. You could be poisoned or severely burned by the sulfuric acid in battery electrolyte. In case of accidental contact with battery electrolyte:**

**EXTERNAL: Flush with water.**

**INTERNAL: Drink large quantities of water or milk. Follow with milk of magnesia, beaten egg, or vegetable oil. Get prompt medical attention.**

**EYES: Flush with water for 15 minutes and get prompt medical attention.**

---

** WARNING**

**Batteries may produce explosive gases. Ventilate when charging or using in a closed space. Keep batteries away from sparks, flames, cigarettes, or other sources of ignition.**

---

## **Battery maintenance**

1. If the vehicle will not be used for a month or longer, remove the battery and store it in a cool, dark place. Completely recharge the battery before reinstallation.

## ***NOTICE***

**A special battery charger (constant voltage/ampere or constant voltage) is required for recharging a sealed-type battery. Using a conventional battery charger may shorten the battery life.**

2. Always make sure the connections are correct when putting the battery back in the vehicle.



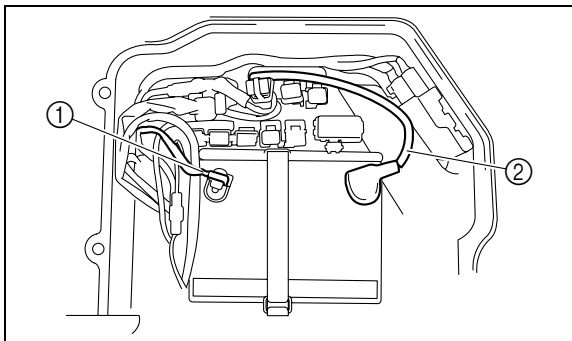

1. Negative battery lead (black)
2. Positive battery lead (red)

## Jump-starting

Jump-starting the vehicle should be avoided. The battery should be removed and charged instead.

### **⚠ WARNING**

**To avoid battery explosion and/or serious damage to the electrical system:**

- Do not connect the negative lead of the jumper cable to the negative terminal of the battery
- Do not touch the positive lead of the jumper cable to the negative lead.
- Do not reverse the polarity of the jumper cables when connecting to the batteries.

However, if the vehicle must be jump-started, proceed as follows.

1. Turn the key to “OFF”.
2. Open the hood. (See pages 8-7–8-8 for hood opening and closing procedures.)
3. Remove the battery compartment cover. (See pages 8-51–8-52 for battery compartment cover removal and installation procedures.)
4. Remove the console. (See page 8-9 for console removal and installation procedures.)
5. Using a charged 12-volt battery, connect the positive lead of the jumper cable to the positive terminal of the battery in the vehicle and the other end of the positive lead to the positive terminal of the charged battery.

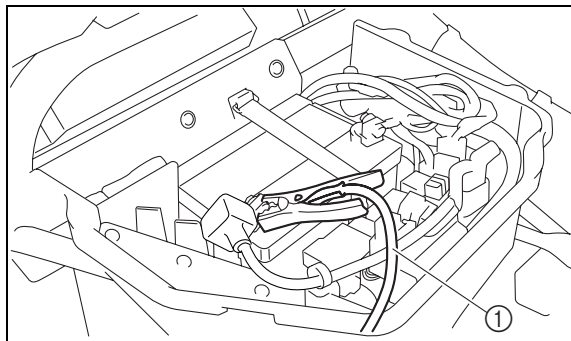

1. Jumper cable positive lead

6. Connect the negative lead of the jumper cable to the negative terminal of the charged battery and the other end of the negative lead to an unpainted metal surface of the crankcase to be started.

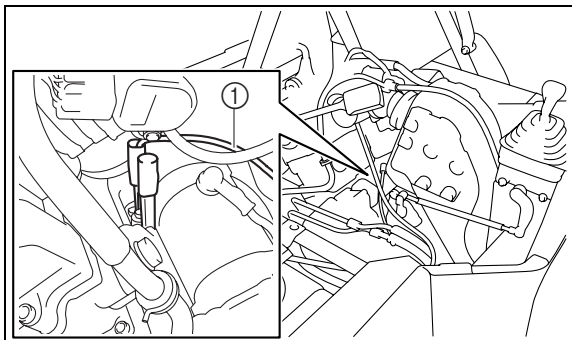

1. Jumper cable negative lead

7. Start the engine. (Refer to “Starting the engine” on pages 6-2–6-3.)
8. After the engine starts, disconnect the negative lead of the jumper cable from the crankcase and charged battery, and then disconnect the positive lead of the jumper cable from the charged battery and the battery in the vehicle.

9. Reinstall the console.
10. Reinstall the battery compartment cover.
11. Close the hood.

## Fuse replacement

The main fuse, the fuel injection system fuse, and the fuse box are located under the hood. (See pages 8-7–8-8 for hood opening and closing procedures.)

If a fuse is blown, turn off the main switch and install a new fuse of the specified amperage.

If a fuse is blown, replace it as follows.

1. Remove the quick fastener screws.
2. Remove the battery compartment cover by lifting it up and pulling it out.

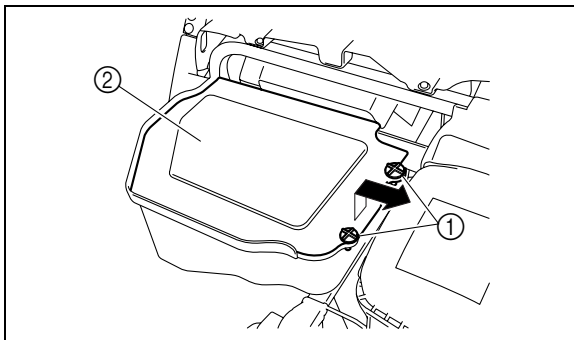

1. Quick fastener screw (× 2)
2. Battery compartment cover

Turn the key to “OFF” and turn off the electrical circuit in question.

## NOTICE

**To prevent accidental short-circuiting, turn off the main switch when checking or replacing a fuse.**

3. Remove the blown fuse, and then install a new fuse of the specified amperage. **WARNING! Always use a fuse of the specified amperage. Never use any material in place of the proper fuse. Using an improper fuse can cause damage to the electrical system and may lead to a fire.**

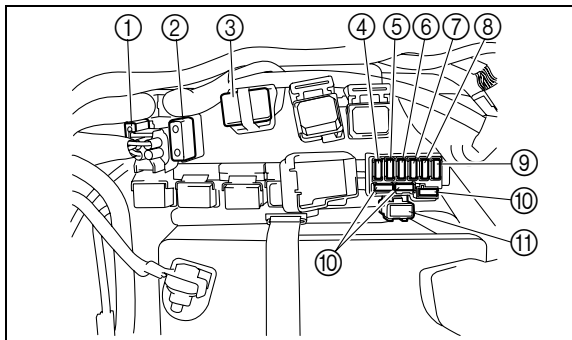

1. Fuel injection system spare fuse
2. Fuel injection system fuse
3. Main fuse
4. Headlight fuse "HEAD"
5. Signaling system fuse "SIGNAL"
6. Auxiliary DC jack fuse "TERMINAL"
7. Four-wheel-drive motor fuse "DIFF"
8. Ignition fuse "IGNITION"
9. Backup fuse "BACK UP" (for odometer and clock)
10. Spare fuse (× 3)
11. Radiator fan fuse "FAN"

#### Specified fuses:

Main fuse:	40.0 A
Fuel injection system fuse:	10.0 A
Headlight fuse:	15.0 A
Ignition fuse:	10.0 A
Auxiliary DC jack fuse:	10.0 A
Signaling system fuse:	10.0 A
Four-wheel-drive motor fuse:	10.0 A
Radiator fan fuse:	25.0 A
Backup fuse:	10.0 A

4. Turn the key to "ON" and turn on the electrical circuit in question to check if the device operates.
5. If the fuse blows again immediately, have a Yamaha dealer check the electrical system.
6. Reinstall the battery compartment cover by installing the quick fastener screws.
7. Close the hood.

## Replacing a headlight bulb

If a headlight bulb burns out, replace it as follows.

1. Lift the hood up. (See pages 8-7–8-8 for hood opening and closing procedures.)
2. Remove the cover at the rear of the headlight by pulling it off.

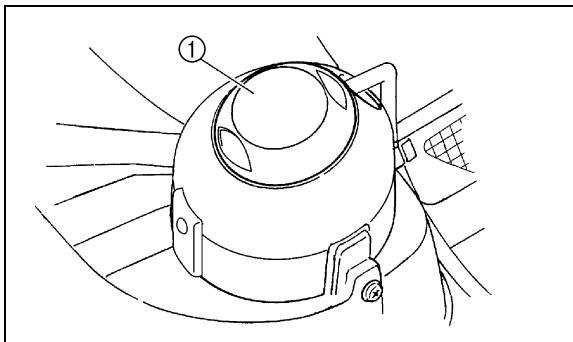

1. Cover at the rear of the headlight

3. Remove the headlight bulb holder cover by pulling it off.

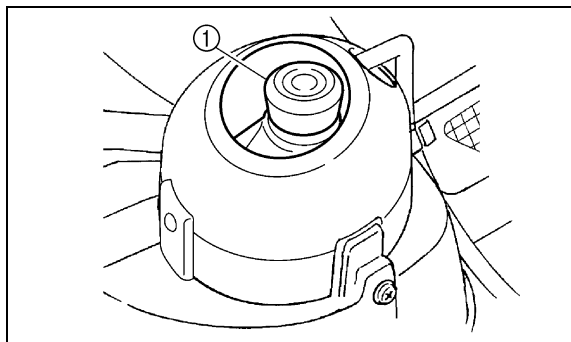

1. Headlight bulb holder cover

4. Remove the headlight bulb holder by pushing it in and turning it counterclockwise.

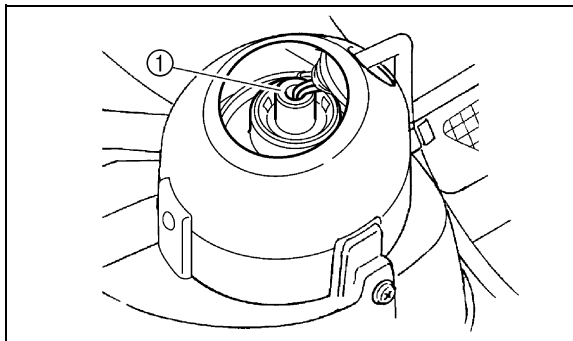

1. Headlight bulb holder

5. Wait for the headlight bulb to cool before touching or removing it. Remove the bulb by pulling it out.
6. Insert a new headlight bulb into the bulb holder by pushing it in.

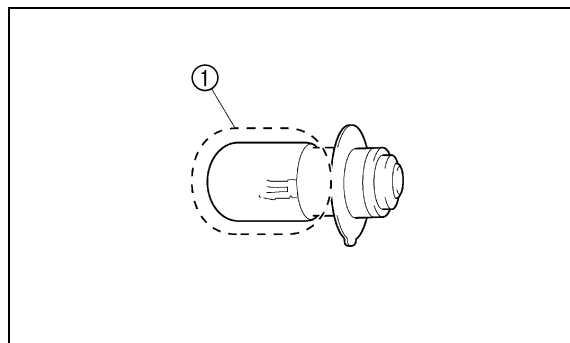

1. Do not touch the glass part of the bulb.

7. Reinstall the bulb holder by pushing it in and turning it clockwise.  
Reinstall the bulb holder cover and the cover at the rear of the headlight.  
**NOTICE: Make sure the headlight bulb holder cover is securely fitted over the bulb holder and seated properly.**
8. Close the hood.
9. Adjust the headlight beam if necessary.

## Headlight beam adjustment

### **NOTICE**

**It is advisable to have a Yamaha dealer make this adjustment.**

To raise the beam, turn the adjusting screw in direction (a).

To lower the beam, turn the adjusting screw in direction (b).

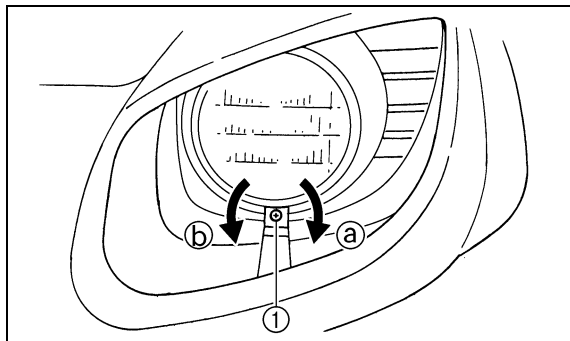

1. Headlight beam adjusting screw



## Tail/brake light bulb replacement

If a tail/brake light bulb burns out, replace it as follows:

1. Remove the quick fastener screws and bolts from panel A (if replacing the left tail/brake light bulb) or panel B (if replacing the right tail/brake light bulb).

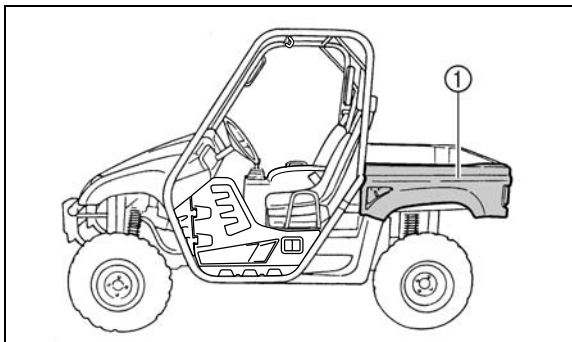

1. Panel A

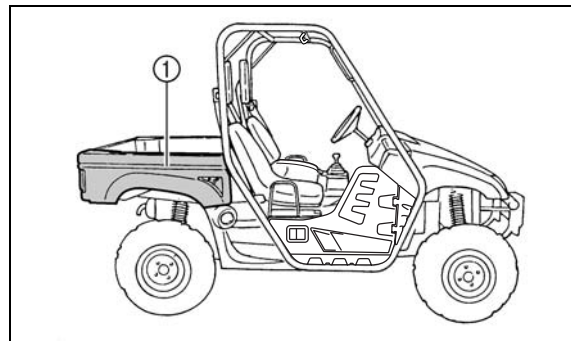

1. Panel B

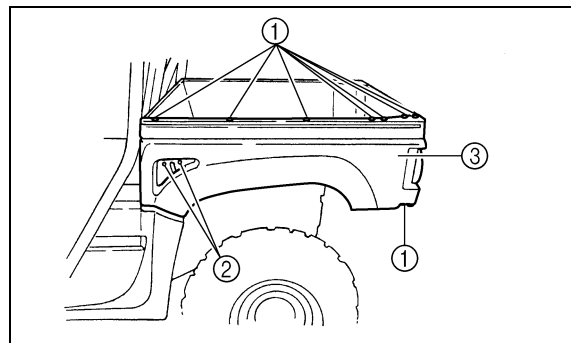

1. Quick fastener screw (× 8)
2. Bolt (× 2)
3. Panel A

2. Lift the cargo bed up. (See pages 4-20–4-21 for cargo bed lifting and lowering procedures.)
3. Remove the panel (panel A or B).
4. Remove the bulb holder (together with the bulb) by turning it counterclockwise.

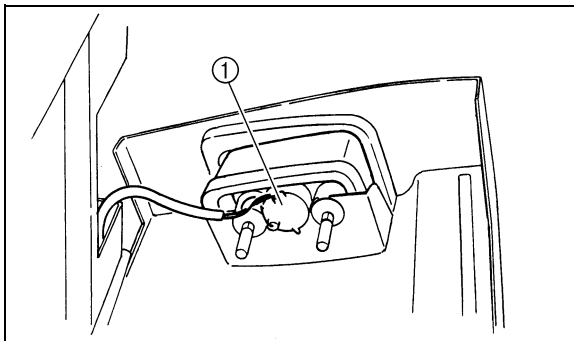

1. Tail/brake light bulb holder

5. Push the defective bulb in and turn it counterclockwise to remove it from the bulb holder.
6. Push a new bulb in and turn it clockwise to install in the bulb holder.

7. Reinstall the bulb holder (together with the bulb) by turning it clockwise.
8. Install the panel.
9. Lower the cargo bed.
10. Reinstall the quick fastener screws and bolts, and then tighten the bolts to the specified torque.

Tightening torque:

Panel bolt:

7 Nm (0.7 m·kgf, 5.1 ft·lbf)

## Troubleshooting

Although Yamaha vehicles receive an inspection before shipment from the factory, trouble may occur during operation. Any problem in the fuel, compression, or ignition systems can cause poor starting and loss of power. The troubleshooting chart describes a quick, easy procedure for making checks. If your vehicle requires any repair, take it to a Yamaha dealer.

The skilled technicians at a Yamaha dealership have the tools, experience, and know-how to properly service your vehicle. Use only genuine Yamaha parts on your vehicle. Imitation parts may look like Yamaha parts, but they are often inferior. Consequently, they have a shorter service life and can lead to expensive repair bills.

## **WARNING**

---

**When checking the fuel system, do not smoke and make sure there are no open flames or sparks in the area, including pilot lights from water heaters or furnaces. Gasoline or gasoline vapors can ignite or explode, causing severe injury or property damage.**

---

# Troubleshooting charts

## Starting problems or poor engine performance

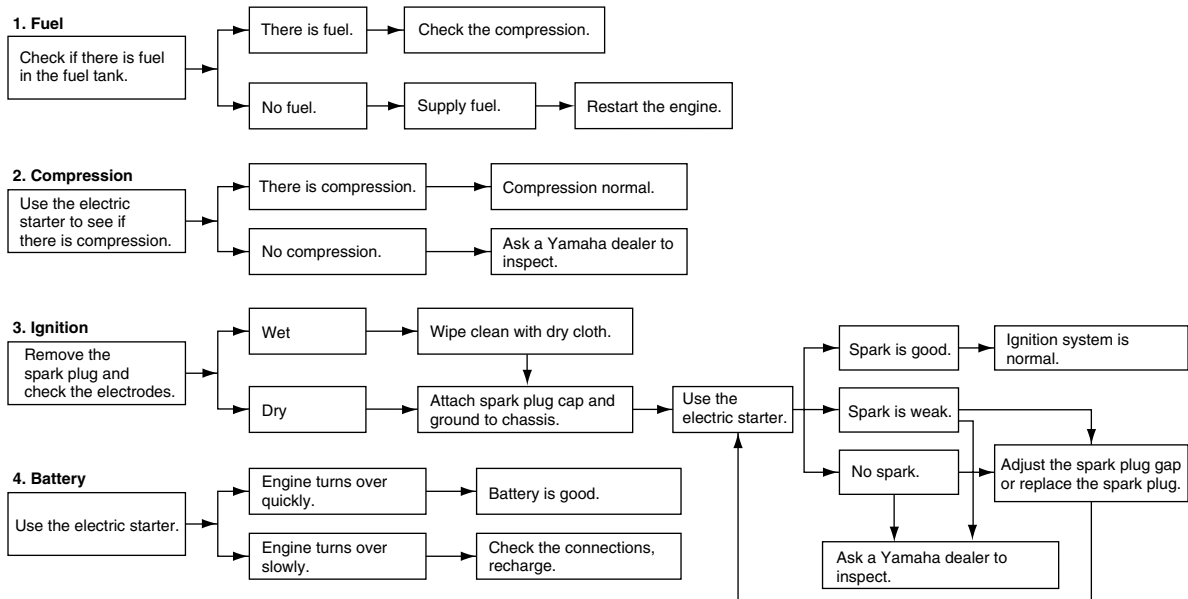

## Engine overheating

Wait for the engine to cool before removing the radiator cap. **WARNING! If the engine is not cool when removing the radiator cap, hot fluid and steam could blow out under pressure and burn you.** Place a thick rag over the cap and remove the cap slowly to allow any remaining pressure to escape.

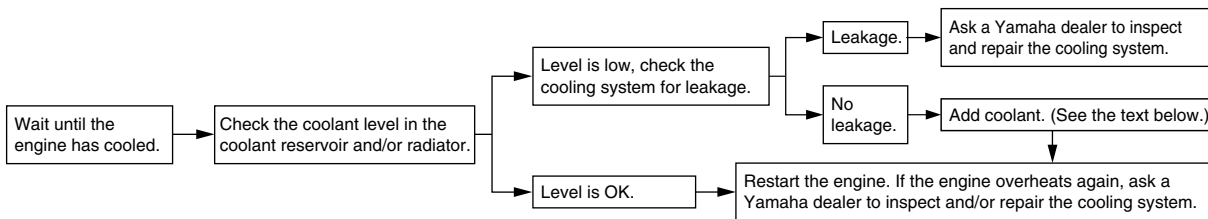

If it is difficult to get the recommended coolant, tap water can be used temporarily, provided that it is changed to the recommended coolant as soon as possible.

# CLEANING AND STORAGE

## A. Cleaning

Frequent, thorough cleaning of your vehicle will not only enhance its appearance but will improve its general performance and extend the useful life of many components.

1. Before cleaning the vehicle:
  - a. Block off the end of the exhaust pipe to prevent water entry. A plastic bag and strong rubber band may be used.
  - b. Make sure the spark plug and all filler caps are properly installed.
2. If the engine case is excessively greasy, apply degreaser with a paint brush. Do not apply degreaser to the wheel axles.
3. Rinse the dirt and degreaser off with a garden hose. Use only enough pressure to do the job. **WARNING! Test the brakes after washing. Apply the brakes several times at slow speeds to let friction dry out the linings. Wet brakes may have reduced stopping ability, increasing the chance of an accident. NOTICE: Excessive water pressure may cause water seepage and deterioration of wheel bearings, brakes, transmission seals and electrical devices. Many expensive repair bills have resulted from improper high-pressure detergent applications, such as those available in coin-operated car washers.**

4. Once the majority of the dirt has been hosed off, wash all surfaces with warm water and mild, detergent-type soap. An old toothbrush or bottle brush is handy for hard-to-get-at places.
5. Rinse the vehicle off immediately with clean water and dry all surfaces with a clean chamois towel or soft, absorbent cloth.
6. Clean the seats with a vinyl upholstery cleaner to keep the covers pliable and glossy.
7. Automotive-type wax may be applied to all painted and chrome-plated surfaces. Avoid combination cleaner-waxes. Many contain abrasives which may scratch the paint or protective finish. When finished, start the engine and let it idle for several minutes.

## **B. Storage**

Long term storage (60 days or more) of your vehicle will require some preventive procedures to guard against deterioration. Make any necessary repairs before storing the vehicle.

After thoroughly cleaning the vehicle, prepare for storage as follows:

1. Fill the fuel tank with fresh fuel and add the specified amount of Yamaha Fuel Stabilizer and Conditioner or equivalent product. Operate the vehicle for at least 5 minutes to distribute treated fuel through the fuel system.

Specified amount:

1 oz of stabilizer to each gallon of fuel (or  
7.5 ml of stabilizer to each liter of fuel)

2. Remove the spark plug, pour about one tablespoon of SAE 10W-40 or 20W-50 motor oil in the spark plug hole and reinstall the spark plug. Ground the spark plug wire and turn the engine over several times to coat the cylinder wall with oil.
3. Lubricate all control cables.
4. Block up the frame to raise all wheels off the ground.
5. Tie a plastic bag over the exhaust pipe outlet to prevent moisture from entering.
6. If storing in a humid or salt-air atmosphere, coat all exposed metal surfaces with a light film of oil. Do not apply oil to any rubber parts or the seat covers.
7. Remove the battery and charge it. Store it in a dry place and recharge it once a month. Do not store the battery in an excessively warm or cold place [less than 0 °C (30 °F) or more than 30 °C (90 °F)].

Use of fuel stabilizer and conditioner eliminates the need to drain the fuel system. Consult a Yamaha dealer if the fuel system needs to be drained.



# SPECIFICATIONS

Model	YXR70FX
Dimensions: Overall length Overall width Overall height  Seat height Wheelbase Ground clearance Minimum turning radius	2,885 mm (113.6 in) 1,385 mm (54.5 in) 1,853 mm (73.0 in) 1,901 mm (74.8 in) (Special Edition model) 818 mm (32.2 in) 1,910 mm (75.2 in) 280 mm (11.0 in) 3,900 mm (154 in)
Basic weight: With oil and full fuel tank	540.0 kg (1,190 lb)
Engine: Engine type Cylinder arrangement Displacement Bore × stroke Compression ratio Starting system Lubrication system	Liquid cooled 4-stroke, SOHC Forward-inclined single cylinder 686.0 cm <sup>3</sup> 102.0 × 84.0 mm (4.02 × 3.31 in) 9.20:1 Electric starter Wet sump



Model	YXR70FX
Final gear case oil: Type Quantity	SAE80 API GL-4 Hypoid gear oil 0.25 L (0.22 Imp qt, 0.26 US qt)
Differential gear case oil: Type Quantity	SAE80 API GL-4 Hypoid gear oil 0.18 L (0.16 Imp qt, 0.19 US qt)
Radiator capacity (including all routes):	2.35 L (2.07 Imp qt, 2.48 US qt)
Air filter: Air filter element	Wet element
Fuel: Type Fuel tank capacity	Unleaded gasoline only 30.0 L (6.60 Imp gal, 7.93 US gal)
Throttle body: Type/quantity Manufacturer	41EHS/1 MIKUNI
Spark plug: Type/manufacturer Spark plug gap	CPR7EA-9/NGK 0.8–0.9 mm (0.031–0.035 in)
Clutch type:	Wet, centrifugal automatic



Model	YXR70FX
Brakes: System Type Operation	Front and rear unified Dual disc brake Dual disc brake Foot operation
Suspension: Front suspension Rear suspension	Double wishbone Double wishbone
Shock absorber: Front shock absorber Rear shock absorber	Coil spring/oil damper Coil spring/oil damper
Wheel travel: Front wheel travel Rear wheel travel	185 mm (7.3 in) 185 mm (7.3 in)
Electrical: Ignition system Generator system Battery type Battery capacity	Transistorized coil ignition (digital) AC magneto U1L-11 12 V 28.0 Ah
Headlight type:	Krypton bulb

Model	YXR70FX
Bulb voltage, wattage × quantity: Headlight Tail/brake light	12 V 30.0 W/30.0 W × 2 12 V 5.0 W/21.0 W × 2
Indicator lights: Neutral indicator light Reverse indicator light Coolant temperature warning light Engine trouble warning light Parking brake indicator light On-Command four-wheel-drive/differential gear lock indicator On-Command differential gear lock indicator light High-range indicator light Low-range indicator light	LED LED LED LED LED LCD LED LED LED

Model	YXR70FX
Specified fuses: Main fuse Fuel injection system fuse Headlight fuse Ignition fuse Auxiliary DC jack fuse Four-wheel-drive motor fuse Signaling system fuse Backup fuse Radiator fan fuse	 40.0 A 10.0 A 15.0 A 10.0 A 10.0 A 10.0 A 10.0 A 10.0 A 25.0 A

# CONSUMER INFORMATION

## Identification number records

Record the key identification number, vehicle identification number, and model label information in the spaces provided for assistance when ordering spare parts from a Yamaha dealer or for reference, in case the vehicle is stolen.

1. KEY IDENTIFICATION NUMBER:

2. VEHICLE IDENTIFICATION NUMBER:

3. MODEL LABEL INFORMATION:



## Key identification number

The key identification number is stamped on the key, as shown in the following illustration. This number can be used for ordering a new key.

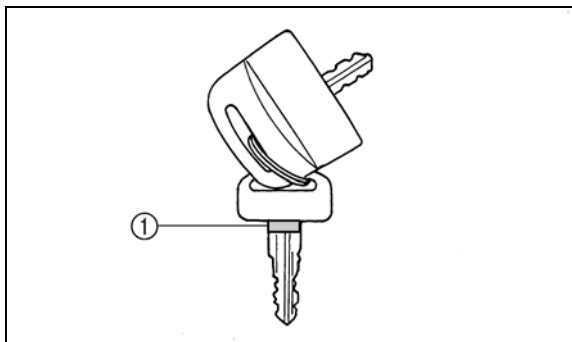

1. Key identification number

## Vehicle identification number

The vehicle identification number is stamped into the frame.

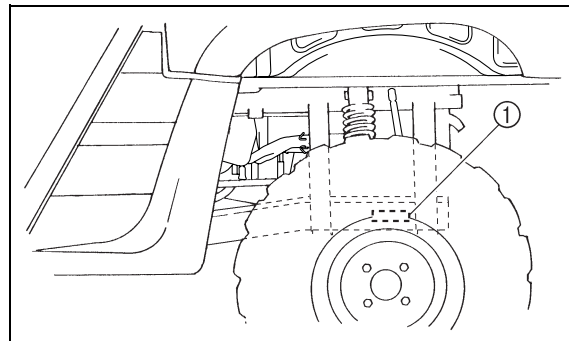

1. Vehicle identification number

The vehicle identification number is used to identify your vehicle.

## Model label

The model label is affixed to the frame under the driver seat. Record the information on this label in the space provided. This information will be needed to order spare parts from your Yamaha dealer.

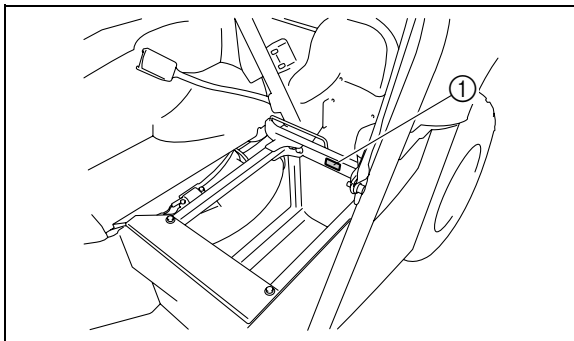

1. Model label

## **NOISE REGULATION**

### **TAMPERING WITH NOISE CONTROL SYSTEM PROHIBITED:**

Federal law prohibits the following acts or the causing thereof: (1) The removal or rendering inoperative by any person other than for purposes of maintenance, repair, or replacement of any device or element of design incorporated into any new vehicle for the purpose of noise control prior to its sale or delivery to the ultimate purchaser or while it is in use or (2) the use of the vehicle after such device or element of design has been removed or rendered inoperative by any person.

“AMONG THOSE ACTS PRESUMED TO CONSTITUTE TAMPERING ARE THE ACTS LISTED BELOW.”

These acts include tampering with the following systems; i.e., modification, removal, etc.

Exhaust system	Muffler Exhaust pipe Silencer
Intake system	Air cleaner case Air cleaner element Intake duct

## MAINTENANCE RECORD

Copies of work orders and/or receipts for parts you purchase and install will be required to document maintenance done in accordance with the warranty. The chart below is printed only as a reminder to you that the maintenance work is required. It is not acceptable proof of maintenance work.

MAINTENANCE INTERVAL			DATE OF SERVICE	MILEAGE	SERVICING DEALER NAME AND ADDRESS	REMARKS
month	km (mi)	hours				
1	320 (200)	20				
3	1,200 (750)	75				
6	2,400 (1,500)	150				
12	4,800 (3,000)	300				
18	7,200 (4,500)	450				
24	9,600 (6,000)	600				
30	12,000 (7,500)	750				
36	14,400 (9,000)	900				
42	16,800 (10,500)	1,050				
48	19,200 (12,000)	1,200				
54	21,600 (13,500)	1,350				
60	24,000 (15,000)	1,500				

# YAMAHA MOTOR CORPORATION, U.S.A. SIDE × SIDE VEHICLE LIMITED WARRANTY

Yamaha Motor Corporation, U.S.A. hereby warrants that new Yamaha Side × Side vehicles purchased from an authorized Yamaha Side × Side Vehicle dealer in the continental United States will be free from defects in material and workmanship for the period of time stated herein, subject to certain stated limitations.

**THE PERIOD OF WARRANTY** for YXR OR YXP Yamaha Side × Side vehicles shall be six (6) months from the date of purchase, with no mileage limitation.

**MODELS EXCLUDED FROM WARRANTY** include those used for non-Yamaha-authorized renting, leasing, or other commercial purposes.

**DURING THE PERIOD OF WARRANTY** any authorized Yamaha Side × Side Vehicle dealer will for free of charge, repair or replace, at Yamaha's option, any part adjudged defective by Yamaha due to faulty workmanship or material from the factory. Parts used in warranty repairs will be warranted for the balance of the product's warranty period. All parts replaced under warranty become property of Yamaha Motor Corporation, U.S.A.

**GENERAL EXCLUSIONS** from this warranty shall include any failures caused by:

- a. Competition or racing use.
- b. Installation of parts or accessories that are not qualitatively equivalent to genuine Yamaha parts.
- c. Abnormal strain, neglect, or abuse.
- d. Lack of proper maintenance.
- e. Accident or collision damage.
- f. Modification to original parts.
- g. Damage due to improper transportation.

**SPECIFIC EXCLUSIONS** from this warranty shall include parts replaced due to normal wear or routine maintenance; such as spark plugs, oil, oil filter, air filter, and brake pads.

**THE CUSTOMER'S RESPONSIBILITY** under this warranty shall be to:

1. Operate and maintain the Side × Side vehicle as specified in the appropriate Owner's Manual, and
2. Give notice to an authorized Yamaha Side × Side Vehicle dealer of any and all apparent defects within ten (10) days after discovery, and make the machine available at that time for inspection and repairs at such dealer's place of business.

**WARRANTY TRANSFER:** To transfer the warranty from the original purchaser to any subsequent purchaser(s), it is imperative that the Side × Side vehicle be inspected and registered for warranty by an authorized Yamaha Side × Side Vehicle dealer. In order for this warranty to remain in effect, this inspection and registration must take place within ten (10) days after transfer of ownership to the subsequent purchaser. A reasonable dealer-imposed fee may be charged for this inspection.

## **EMISSION CONTROL SYSTEM WARRANTY**

Yamaha Motor Corporation, U.S.A. also warrants to the ultimate purchaser and each subsequent purchaser of each 2006 and later model Yamaha Side × Side vehicle covered by this warranty that the vehicle is designed, built, and equipped so as to conform at the time of sale with all U.S. emissions standards applicable at the time of manufacture and that it is free from defects in materials and workmanship which would cause it not to meet these standards within the period listed immediately below. Failures other than those resulting from defects in material or workmanship which arise solely as a result of owner abuse and/or lack of proper maintenance are not covered by this warranty.

## **ALL MODELS**

Thirty (30) months from the original purchase date

**YAMAHA MOTOR CORPORATION, U.S.A. MAKES NO OTHER WARRANTY OF ANY KIND, EXPRESSED OR IMPLIED. ALL IMPLIED WARRANTIES OF MERCHANTABILITY AND FITNESS FOR A PARTICULAR PURPOSE WHICH EXCEED THE OBLIGATIONS AND TIME LIMITS STATED IN THIS WARRANTY ARE HEREBY DISCLAIMED BY YAMAHA MOTOR CORPORATION, U.S.A. AND EXCLUDED FROM THIS WARRANTY.**

**SOME STATES DO NOT ALLOW LIMITATIONS ON HOW LONG AN IMPLIED WARRANTY LASTS, SO THE ABOVE LIMITATION MAY NOT APPLY TO YOU. ALSO EXCLUDED FROM THIS WARRANTY ARE ANY INCIDENTAL OR CONSEQUENTIAL DAMAGES INCLUDING LOSS OF USE. SOME STATES DO NOT ALLOW THE EXCLUSION OR LIMITATION OF INCIDENTAL OR CONSEQUENTIAL DAMAGES, SO THE ABOVE EXCLUSION MAY NOT APPLY TO YOU. THIS WARRANTY GIVES YOU SPECIFIC LEGAL RIGHTS, AND YOU MAY ALSO HAVE OTHER RIGHTS WHICH VARY FROM STATE TO STATE.**

## YAMAHA EXTENDED SERVICE (Y.E.S.)

Keep your Yamaha protected even after your warranty expires with genuine Yamaha Extended Service (Y.E.S.).

- Y.E.S. is designed and administered by Yamaha Motor Corporation to provide maximum owner satisfaction. You get uninterrupted factory-backed coverage for extra peace of mind.
- Y.E.S. is flexible. You choose the plan that's right for you: 12 months, 24 months, or 36 months beyond your warranty period.
- Y.E.S. is designed and administered by the same Yamaha people who handle your warranty – and it shows in the comprehensive coverage benefits. There are no mileage limitations. Coverage isn't limited to "moving parts" or the "drive train" like many other plans. And Y.E.S. covers manufacturing defects just like the warranty. See the sample contract at your Yamaha dealer to see how comforting uninterrupted factory-backed protection can be.
- You don't have to pay anything for covered repairs. There's no deductible to pay, and repairs aren't "pro-rated." You don't have any "out-of-pocket" expenses for covered repairs.

- In addition, Travel and Recreation Interruption Protection (TRIP) is included at no extra cost. TRIP gives you up to \$150 reimbursement per occurrence for any reasonable expenses you incur because your Yamaha needs covered service: replacement vehicle rental, emergency towing, phone calls, even food and lodging when you are away from home. This superb coverage goes into effect when you purchase Y.E.S., so it applies to any warranty repairs as well as covered repairs during your entire Y.E.S. plan period.
- Y.E.S. coverage is honored at any authorized Yamaha dealer nationwide.
- Y.E.S. coverage is transferable to a new owner if you sell or trade-in. That can make your Yamaha much more valuable!

This excellent Y.E.S. plan coverage is only available to Yamaha owners like you, and only while your Yamaha is still within the Yamaha Limited Warranty period. So visit your authorized Yamaha dealer to get all the facts. He can show you how easy it is to protect your investment with Yamaha Extended Service.

We urge you to act now. You'll get the excellent benefits of TRIP coverage right away, and you'll rest easy knowing you'll have strong factory-backed protection even after your Yamaha Limited Warranty expires. You can also save money: Y.E.S. costs less within the first 90 days after you buy your Yamaha. See your dealer today!

A special note:

If visiting your dealer isn't convenient, contact Yamaha with your Primary ID number (your frame number). We'll be happy to help you get the Y.E.S. coverage you need.

Yamaha Service Marketing  
P.O. Box 6555  
Cypress, CA 90630



**YAMAHA EXTENDED SERVICE**







***PROTECT YOUR INVESTMENT***

***Use Genuine YAMAHA Parts And Accessories***

***See your Authorized YAMAHA Dealer for a Genuine YAMAHA  
Service Manual.***



**YAMAHA**

YAMAHA MOTOR CO., LTD.

PRINTED IN USA  
2007.09-6.5x1 CR  
(E)