



MIXING CONSOLE

AG06 Technical Specifications

ZN24170

General Specifications

0 dBu = 0.775 Vrms, Output impedance of signal generator (Rs) = 150 Ω

All level controls are nominal if not specified.

Frequency Response	Input (MIC) to MONITOR OUT via USB IN/OUT	+0.5 dB/-1.5 dB (20 Hz to 48 kHz @ Fs = 192 kHz), refer to the nominal output level @ 1 kHz, GAIN knob: Min, TO PC: DRY CH1-2
Total Harmonic Distortion *1 (THD+N)	Input to MONITOR OUT	0.05% @ 0 dBu (20 Hz to 20 kHz), GAIN knob: Min 0.01% @ +4 dBu (1 kHz), GAIN knob: Min
Hum&Noise *2 (20 Hz to 20 kHz)	Equivalent Input Noise	-128 dBu (Mono Input Channel, Rs: 150 Ω, GAIN knob: Max)
	Residual Output Noise	-103 dBu (MONITOR OUT, MONITOR knob: Min)
Crosstalk (1 kHz) *3		-80 dB
Input Channels		Mono (MIC/LINE): 2 including HEADSET MIC (Plug-in Power) (CH1 MIC and HEADSET MIC cannot be used simultaneously.), Stereo (LINE): 2, USB IN: 1, AUX IN: 1
Output Channels		STEREO OUT: 1, MONITOR OUT: 1, PHONES: 2 including HEADSET PHONES (PHONES and HEADSET PHONES cannot be used simultaneously.)
Bus		Stereo: 1
Input Channel Function (CH1, CH2)	PAD	26 dB
	DSP	CH1: COMP/EQ, EFFECT (SPX Reverb) CH2: AMP SIM, EFFECT (SPX Reverb)
	PEAK LED	LED turns on when the signal reaches 3 dB below clipping level.
Level Meter	USB Output Level	2x2 point LED meter [PEAK, SIG]
USB Audio	2 IN / 2 OUT	USB Audio Class 2.0 compliant, Sampling Frequency: Max 192 kHz, Bit Depth: 24-bit
Phantom Power Voltage		+48 V
FOOT SW		EFFECT Mute on/off
Power Requirements		DC 5 V, 500 mA
Power Consumption		Max. 2.5 W
Dimensions (WxHxD)		155 mm x 63 mm x 202 mm (6.1" x 2.5" x 8.0")
Net Weight		1.0 kg (2.2 lbs)
Included Accessory		USB Cable (1.5 m), CUBASE AI DOWNLOAD INFORMATION, Owner's Manual, Technical Specifications (this leaflet)
Optional Accessory		Foot Switch: FC5, Mic Stand Adaptor: BMS-10A
Operating Temperature		0 to +40°C

*1 THD+N is measured with 22 kHz LPF.

*2 Noise is measured with A-weighting filter.

*3 Crosstalk is measured with 1 kHz band pass filter.

The contents of this manual apply to the latest specifications as of the printing date. Since Yamaha makes continuous improvements to the product, this manual may not apply to the specifications of your particular product. To obtain the latest manual, access the Yamaha website then download the manual file. Since specifications, equipment or separately sold accessories may not be the same in every locale, please check with your Yamaha dealer.

Analog Input Characteristics

0 dBu = 0.775 Vrms

Input Jack	PAD 26 dB	GAIN Trim/SW Position	Actual Load Impedance	For Use with Nominal	Input Level			Connector
					Sensitivity *1	Nominal	Max. Before Clip	
MIC/LINE 1 - 2 HEADSET MIC	OFF	10	3 kΩ 1.5 kΩ *4	50-600 Ω Mics/Lines	-72 dBu (0.195 mV)	-60 dBu (0.775 mV)	-50 dBu (2.451 mV)	Combo jack *2 (Balanced) 3.5 mm Phone jack For CH1 HEADSET MIC (Plug-in Power/ Unbalanced)
		0			-26 dBu (38.84 mV)	-14 dBu (154.6 mV)	-4 dBu (489.0 mV)	
	ON	10			-46 dBu (3.884 mV)	-34 dBu (15.46 mV)	-24 dBu (48.90 mV)	
		0			0 dBu (775.0 mV)	+12 dBu (3.085 V)	+22 dBu (9.757 V)	
INPUT CH2 GUITAR *5	OFF	10	1 MΩ	-	-68 dBu (3.085 mV)	-56 dBu (1.228 mV)	-46 dBu (3.884 mV)	Phone jack *3 (Unbalanced)
		0			-22 dBu (61.56 mV)	-10 dBu (245.1 mV)	0 dBu (775.0 mV)	
	ON	10			-42 dBu (6.153 mV)	-30 dBu (24.51 mV)	-20 dBu (77.5 mV)	
		0			+4 dBu (1.228 V)	-	+10 dBu (2.451 V)	
LINE 3/4, 5/6	-	HIGH	10 kΩ	600 Ω Lines	-20 dBu (77.5 mV)	-8 dBu (308.5 mV)	+2 dBu (975.7 mV)	LINE 3/4 Phone jack *3 (Unbalanced)
		LOW			-10 dBu (245.1 mV)	+2 dBu (975.7 mV)	+12 dBu (3.085 V)	LINE 5/6 RCA pin (Unbalanced)
AUX	-	-	10 kΩ	600 Ω Lines	-14 dBu (154.6 mV)	-8 dBu (308.5 mV)	+2 dBu (975.7 mV)	Stereo mini jack

*1 Sensitivity is the lowest level that will produce an output of +0 dBu (0.775 V) or the nominal output level when the unit is set to maximum gain. (All level controls are at their maximum position.)

*2 1&Sleeve = GND, 2&Tip = HOT, 3&Ring = COLD

*3 Tip = Signal, Sleeve = GND

*4 For CH1, HEADSET MIC

*5 For CH2, GUITAR switch is ON

Analog Output Characteristics

0 dBu = 0.775 Vrms

Output Terminal	Actual Source Impedance	For Use with Nominal	Output Level		Connector
			Nominal	Max. Before Clip	
STEREO OUT [L, R]	150 Ω	10 kΩ Lines	0 dBu (0.775 V)	+10 dBu (2.451 V)	Phone jack *6 (Impedance Balanced)
MONITOR OUT [L, R]	150 Ω	10 kΩ Lines	0 dBu (0.775 V)	+10 dBu (2.451 V)	Phone jack *6 (Impedance Balanced)
PHONES	120 Ω	40 Ω Phones	1.5 mW + 1.5 mW	6 mW + 6 mW	Stereo phone jack Stereo mini jack

*6 Tip = HOT, Ring = COLD, Sleeve = GND

Digital Input / Output Characteristics

Terminal	Format	Data Length	Sampling Frequency	Connector
USB	USB Audio Class 2.0/ Yamaha Steinberg USB Driver	24-bit	44.1 kHz, 48 kHz, 88.2 kHz, 96 kHz, 176.4 kHz, 192 kHz	USB Standard-B

Block and Level Diagrams

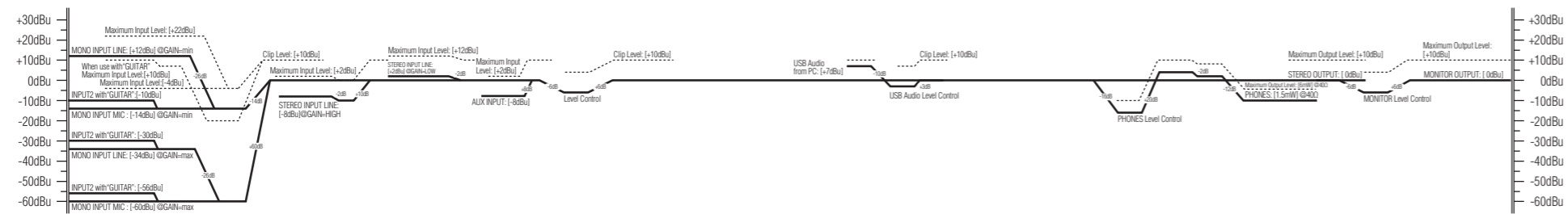
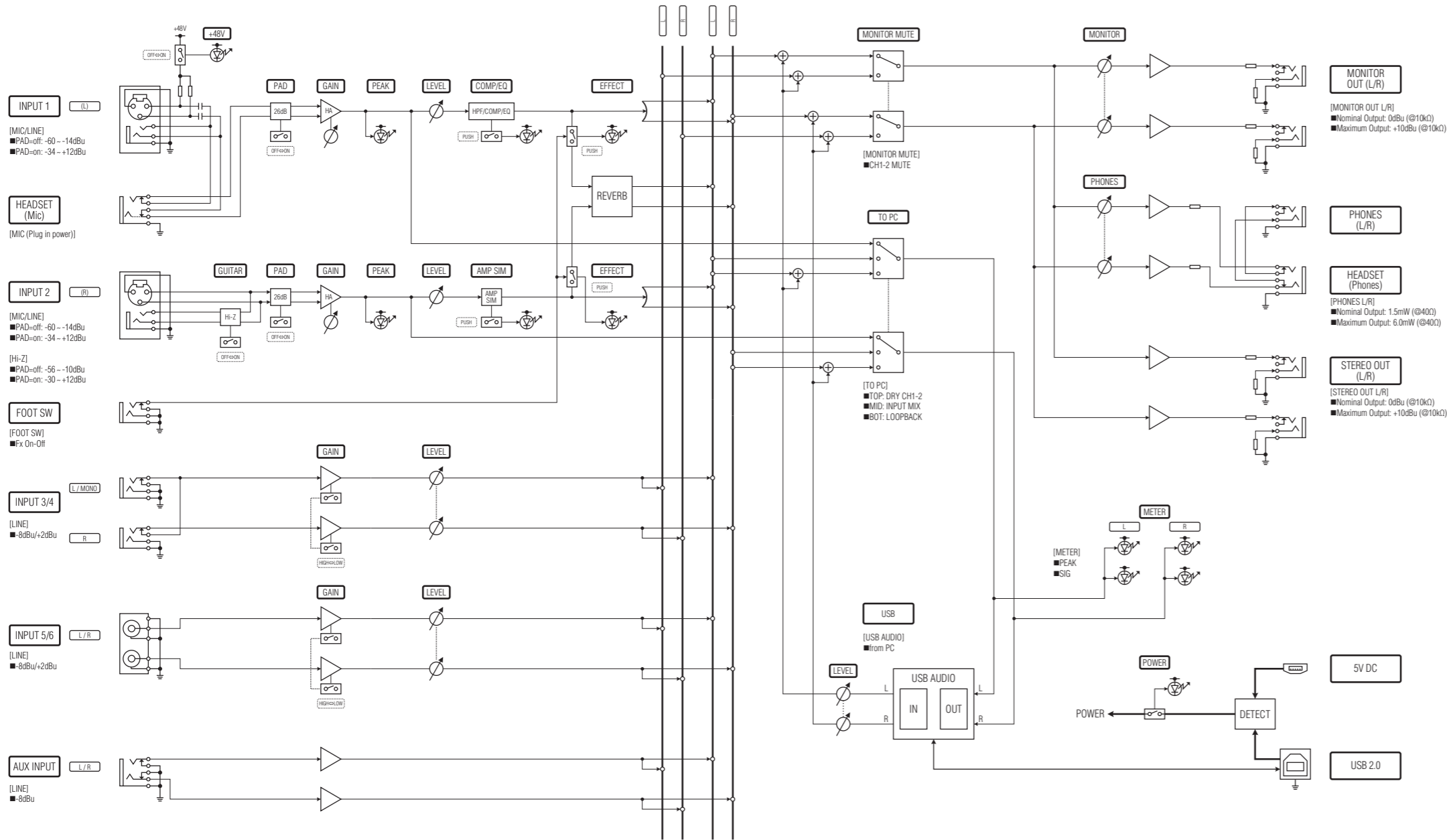

Dimensions

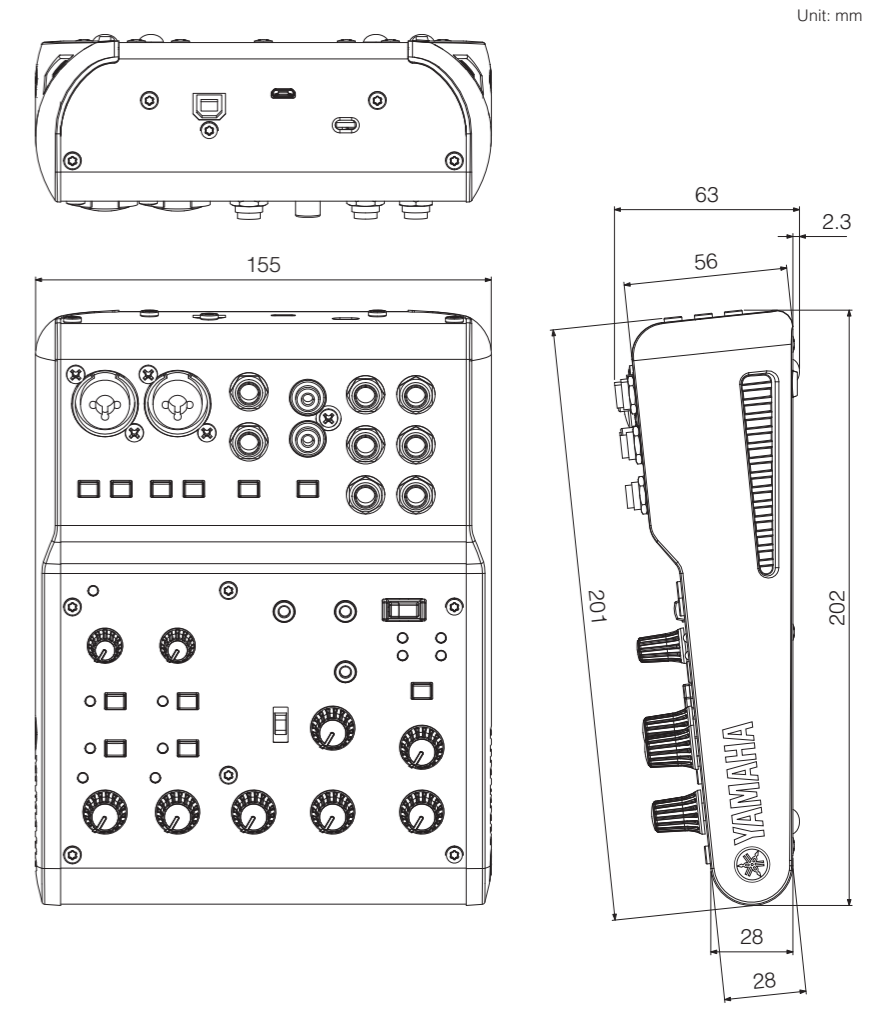

Jack and Plug List

Jacks and Plugs	Polarities	Balanced/Unbalanced	Configurations
MIC/LINE	Pin 1: Ground Pin 2: Hot (+) Pin 3: Cold (-)	Balanced	XLR Jack INPUT
MIC/LINE* STEREO OUT* MONITOR OUT*	Tip: Hot (+) Ring: Cold (-) Sleeve: Ground	Balanced	TRS Phone Plug
HEADSET MIC	Tip: Signal Ring: - Sleeve: Ground	Unbalanced	
PHONES AUX	Tip: L Ring: R Sleeve: Ground	-	TS Phone Plug
LINE 3/4 GUITAR	Tip: Signal Sleeve: Ground	Unbalanced	

* These jacks also can be connected with TS phone plugs. If you use TS phone plugs, the connection will be unbalanced.