



Heating and Air Conditioning

TECHNICAL GUIDE

AFFINITY™ SERIES

EXPORT ONLY

SINGLE PACKAGE GAS/ELECTRIC

AIR COOLED AIR CONDITIONERS

2.5 THROUGH 5 NOMINAL TON

DNA030 THROUGH 060

8.6 - 9.2 EER

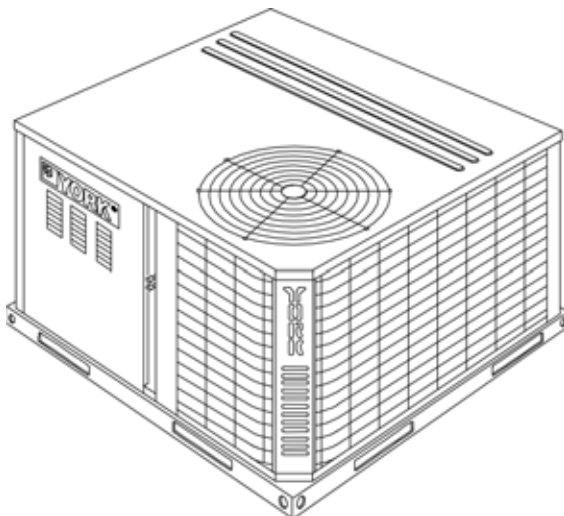

FLEXIBLE LIGHT COMMERCIAL UNIT

GENERAL

York® Affinity™ Series packaged units are designed to handle applications ranging from residential to light commercial and any in between. The Affinity™ is a unit that gives you the flexibility and choices you need in today's market.

FEATURING

- COOLING/GAS HEATING UNITS (NATURAL GAS OR PROPANE)
- LOW PROFILE
- QUIET OPERATION
- COMMON FOOTPRINT
- OPTIONAL SLIDE IN MOTORIZED DAMPERS
- OPTIONAL SLIDE IN ECONOMIZERS
- OPTIONAL PROPANE CONVERSION KIT
- OPTIONAL HIGH ALTITUDE CONVERSION KIT (NATURAL GAS/PROPANE)
- FULL PERIMETER BASE RAILS
- BOTTOM AND SIDE UTILITY CONNECTIONS



ISO 9001
Certified Quality
Management System

TABLE OF CONTENTS

DESCRIPTION 3
STANDARD FEATURES/BENEFITS 3
FIELD-INSTALLED ACCESSORIES 4
TYPICAL WIRING DIAGRAM NOTES 24
MECHANICAL SPECIFICATIONS 24

LIST OF FIGURES

Fig. #	Pg. #
1	PRODUCT NOMENCLATURE2
2	UNIT COMPONENT LOCATION5
3	TYPICAL FIELD CONTROL WIRING DIAGRAM ...14
4	TYPICAL FIELD POWER WIRING DIAGRAM15
5	UNIT DIMENSIONS - FRONT16
6	UNIT DIMENSIONS - FRONT & BOTTOM17
7	UNIT DIMENSIONS - BACK & BOTTOM17
8	TYPICAL SLAB ON GROUND INSTALLATION18
9	TYPICAL ROOF CURB INSTALLATION18
10	TYPICAL DUCT APPLICATIONS19
11	UNIT CENTER OF GRAVITY19
12	ROOF CURB DIMENSIONS20
13	ROOF CURB CROSS SECTION20
14	TYPICAL WIRING DIAGRAM DNA 030 THRU 060 (208/230-1-60 POWER SUPPLY)21
15	TYPICAL WIRING DIAGRAM DNA 036, 042, 048, 060 (208/230-3-60 POWER SUPPLY)22
16	TYPICAL WIRING DIAGRAM DNA 036, 042, 048, 060 (460-3-60 POWER SUPPLY)23
17	TYPICAL WIRING DIAGRAM LEGEND24

LIST OF TABLES

Tbl. #	Pg. #
1	PHYSICAL DATA 6
2	RATINGS COOLING/GAS HEATING 7
3	DNA030 COOLING CAPACITIES - 2-1/2 TON 8
4	DNA036 COOLING CAPACITIES - 3 TON 9
5	DNA042 COOLING CAPACITIES - 3-1/2 TON 10
6	DNA048 COOLING CAPACITIES - 4 TON 11
7	DNA060 COOLING CAPACITIES - 5 TON 12
8	SIDE SUPPLY AIR BLOWER PERFORMANCE 13
9	BOTTOM SUPPLY AIR BLOWER PERFORMANCE 13
10	ADDITIONAL STATIC PRESSURE RESISTANCE 2-1/2 - 3-1/2 TON (DNA030 - 042) 14
11	ADDITIONAL STATIC PRESSURE RESISTANCE 4 - 5 TON (DNA048 - 060) 14
12	ELECTRICAL DATA 15
13	UNIT DIMENSIONS FRONT 16
14	UNIT MINIMUM CLEARANCES 16
15	UNIT WEIGHTS AND CENTER OF GRAVITY 19

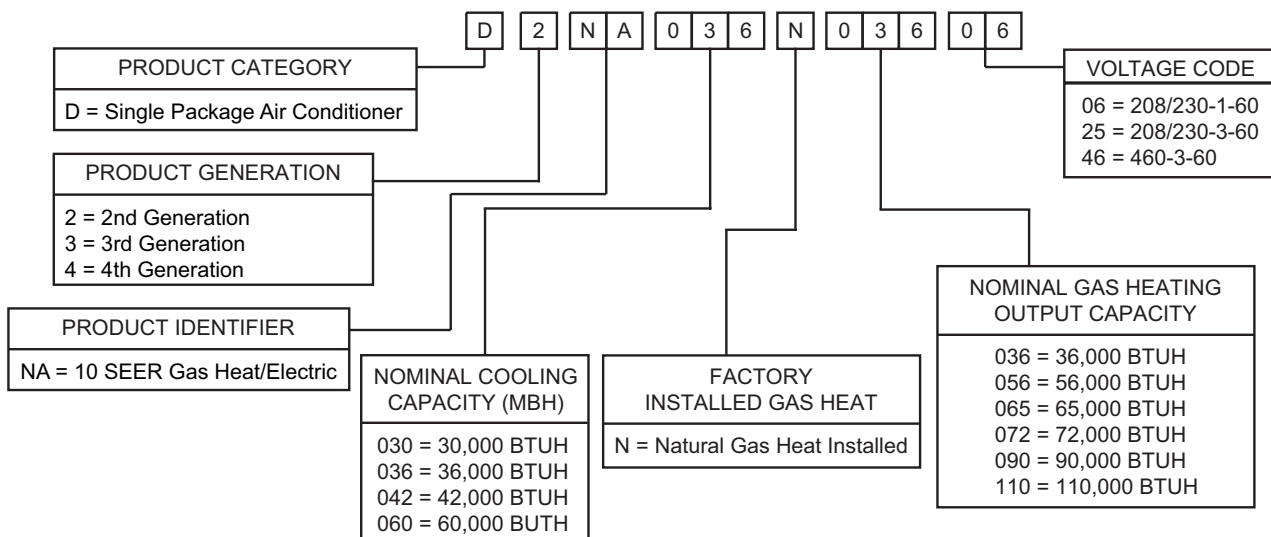

FIGURE 1 - PRODUCT NOMENCLATURE

DESCRIPTION

These packaged cooling/heating air conditioners are designed for outdoor installation. Only utility and duct connections are required at the point of installation.

The gas-fired heaters have aluminized steel tubular heat exchangers and spark to pilot ignition. They are available in natural gas with field conversion to propane.

STANDARD FEATURES/BENEFITS

OPERATING EFFICIENCY - All units provide high operating efficiencies and have a minimum AFUE of 80% and EERs of 8.6 to 9.2. All efficiencies exceed legislated minimum levels.

ON SITE FLEXIBILITY - All model sizes share a common, compact design cabinet in a single footprint. The installer has the flexibility of setting one curb and placing the proper tonnage unit on that curb after the internal load has been determined. Field convertible duct connections from side shot to down shot allows the installer to have greater flexibility with less inventory.

LOWER INSTALLATION COST - Installation time and costs are reduced by easy power and control wiring connections. The small base dimension means less space is required on the ground or roof, plus, the installer can fit this unit between the wheel wells of full size pick-up truck. All models are well under 500 pounds.

All units are completely wired, charged with R-22 and tested prior to shipment. Unique test stations using a new state of the art computerized process system are used to insure product quality. Refrigerant charge, and component part numbers are verified via computers at assembly. Vital run test statistics such as system pressure, motor currents, air velocity and temperature, unit vibration, and gas system safeties are monitored and recorded by the system to insure unit performance.

Equal size, side supply and return duct connections allows easy hook-up of ducts to match low crawl spaces without transition pieces.

UTILITY CONNECTIONS MADE EASY - Gas and electric utility knockouts are provided through the bottom as well as the side of the unit. Utility connections can be made quickly and with a minimum amount of field labor. A field supplied and field installed electrical disconnect switch must be installed.

CONVERTIBLE AIRFLOW DESIGN - The bottom duct openings are covered when they leave the factory ready to be used for a side supply / side return application. If a bottom supply / bottom return application is desired, you simply remove the two panels from the bottom of the unit and place them in the side supply / side return duct openings. No panel cutting is required and no accessory panel is necessary. Convertible airflow design allows maximum field flexibility and minimum inventory.

CONDENSATE PAN - A non-corrosive, long-lasting, water-tight pan is positioned below the evaporator coil to collect and drain all condensate. Less collection of stagnate condensate will build-up. The condensate pan conforms to ASHRAE 62-89 standards (Ventilation for Acceptable Indoor Air Quality).

CONDENSATE DRAIN - The heavy duty, 3/4 inch NPTI copper connection is more tolerable during installation and is more durable over time. The connection is rigidly mounted to assure proper fit and leak tight seal.

DURABLE FINISH - With a heavy duty cabinet made of powder-painted, galvanized steel the neutral color blends into surrounding areas. The powdered paint, provides a better paint to steel bond, which resists corrosion and rust creep. The special primer formulas and glossy finish insure less fading when exposed to sunlight and offers a more attractive on site appearance. This paint finish meets ASTM-B117 standards for 1000 hours salt spray rating. The highest in the industry.

FULL PERIMETER BASE RAILS - The easily removable base rails provide a solid foundation for the entire unit and protects the unit during shipment. The rails provide fork lift access from all sides, and rigging holes are also provided so that an overhead crane can be used to place the units on a roof. On applications where the unit is placed on a pad, the base will keep the unit off the pad to deter corrosion. On applications where height is limited, the inch high base rails may be removed on location.

MORE ATTRACTIVE APPEARANCE - A single piece Water Shed top cover containing a top discharge condenser fan arrangement requires less square footage on installation and provides a wider variety of installations. The one piece design adds greater water integrity. Rounded corners with water drip edges add to the attractive appearance. The cabinet panels have a non-fibrous insulation that will not release insulation fibers into conditioned area.

TOP DISCHARGE - The top discharge condenser fan does not disrupt neighboring areas or does this dry-out vegetation surrounding the unit. The warm air from the top mounted fan is blown up away from the structure and any landscaping. This allows compact location on multi-unit applications.

CONDENSER COIL GRILLE - A multi-piece totally enclosed, rigidly mounted condenser coil grille provides protection from objects after installation and provides protection during transit.

LOW OPERATING SOUND LEVEL - The upward air flow carries the normal operating noise up and away from the living area. The rigid top panel effectively isolates any motor sound. Isolator mounted compressor and the rippled fins of the condenser coil muffle the normal fan motor and compressor operating sounds. The unique formed base pan also aids in sound alterations with it's Super-Structure design. This design strategically places embossments in the pan for optimum strength and rigidity.

FAN SYSTEM - All models operate over a wide range of design conditions with a 3-speed direct-drive fan motor. These units easily match all types of applications and provides greater on site flexibility to match comfort requirement.

SIMPLE CONTROL CIRCUIT - A low voltage printed circuit board contains a diagnostic indicator light and a low voltage terminal strip. An additional set of pin connectors is also provided to simplify the field interface of external controls. Mate-n-lock plug connectors are used. The electrical control box is not located in the compressor compartment. The controls are mounted on a Control-Tilt control panel to allow the access cover to be removed for trouble shooting and maintenance without affecting the normal system operating pressures. All wiring internal to the unit is color/number coded.

PROTECTED COMPRESSOR - The compressor is internally protected against high pressure and temperature. This is accomplished by the simultaneous operation of high pressure relief valve and a temperature sensor which protect the compressor if undesirable operating conditions occur.

EXCLUSIVE COIL DESIGN - Grooved copper tubes and enhanced aluminum fin construction improves heat transfer for maximum efficiency and durability.

HEAT EXCHANGERS - Are corrosion-resistant, aluminized-steel tubular construction to provide long-life, trouble-free operation. The unique blow-through design also assures that condensate does not collect in humid areas when in the cooling cycle. This adds to longer heat exchanger life and higher long term efficiencies.

POST PURGE INDUCED DRAFT COMBUSTION - Exhausts combustion products from the heat exchanger upon completion of the heating cycle to prolong the heat exchanger life.

SELF DIAGNOSTIC FAN CONTROL MODULE - Due to this self diagnostic control, less on site time is required to trouble shoot these units.

SPARK TO PILOT IGNITION - Provides faster heat delivery. This ignition is highly reliable, durable and eliminates nuisance lockouts.

MULTI PORT IN-SHOT BURNERS - No field adjustment is required to mix the air and gas. These burners are constructed of high-grade corrosion-resistant, aluminized-steel.

LOW MAINTENANCE - Long life, permanently lubricated condenser and evaporator fan motor bearings need no annual maintenance adding greater reliability to the unit. Blower assembly can be easily cleaned by the unique Slip-Track slide-out blower assembly.

SECURED SERVICE ACCESS PORTS - Protected, externally mounted, re-usable service access ports are provided on both the high and low lines for ease of evacuating and charging the system. No final field mounting required.

EASY SERVICE ACCESS - A large, single panel covers the electrical and gas controls makes servicing easy. The blower

compartment has an additional large panel with a built-in handle tab. Removing this panel will allow the blower assembly to slide-out for easy removal for maintenance and ease of trouble shooting.

REPLACEMENT PARTS - The installer has no need to carry an inventory of unique parts or needs special training to replace any of the components parts for these units. All are easily obtained from Source 1 or other part houses.

SYSTEM INTEGRATION - Each unit has the internal ability to integrate an electronic air cleaner or humidifier to work in conjunction with the base unit.

FIELD-INSTALLED ACCESSORIES

PROPANE CONVERSION KIT - Kit includes burner orifices, gas valve conversion and installation instructions necessary to field convert unit from natural gas to propane.

HIGH ALTITUDE CONVERSION KIT (Natural Gas/Propane) - Kit includes all necessary labels and instructions to field alter units with natural gas/propane for installation above 2000 feet. Burner orifices must be obtained from Source 1 Parts. Propane Conversion Kit must be obtained separately.

ECONOMIZER DOWN DISCHARGE / SUPPLY KIT - Modulating integrated economizer provides simultaneous operation between the mechanical cooling and economizer operation. Independent blade design insures proper control and less than 1% leak rate. Includes hood and mesh bird screen filter integrated into the hood, dry bulb sensor and relief damper. Separate field accessories of single enthalpy and dual enthalpy are also available. A built-in barometric relief of 25% is provided.

SINGLE ENTHALPY SENSOR - Sensor replaces dry bulb sensor standard in economizer kit. Provides improved economizer operation by sensing the dry bulb temperature from outdoors plus the enthalpy content of the outdoor air.

DUAL ENTHALPY SENSOR - Additional sensor to single enthalpy sensor. Sensor senses both the return air temperature dry bulb and humidity in conjunction with the single enthalpy to determine the most economical mix. Single Enthalpy sensor also required.

PRESSURE SWITCH UPGRADE KIT - Contains screw in type High pressure, Low Pressure/Loss of Charge switch, freeze protection switch and lockout relay. Switches are placed onto existing scharder ports located in the unit by furnished adapters. When abnormal conditions are sensed through the pressure switches, the unit will lock out preventing any further operation until reset or problem is corrected. Package agency approved.

HAIL GUARD KIT - Kit contains protective grilles made of expanded aluminum with full perimeter frame. Sloped hoods are also included to assure maximum protection.

ANTI SHORT CYCLE TIMER - Automatically prevents the compressor from restarting for 5 minutes after cycled off. Not

required if Thermostat 2ET07700224 and 2ET04700224 are used.

MOTORIZED FRESH AIR DAMPER - Designed for duct mounted side supply/return and unit mounted down supply/return applications. Damper capable of providing 0% through 50% of outdoor air (field supplied). Closes on power loss, includes hood and screen assembly.

FILTER / FRAME KIT (Single Phase only) - Kit contains the necessary hardware to field install return air filters into the base unit. Pre-cut filter racks and appropriate cleanable standard size filters are shipped in one kit. The filter rack is suitable for either 1" or 2" filters (1" filter is supplied). This kit is available for single phase horizontal or vertical duct application only. Standard in all 3 phase models

RECTANGLE TO ROUND ADAPTERS - Kit includes one supply and one return air rectangle to round duct adapter. Adapters are preformed and designed to fit over current duct openings on the base unit. Transition is from side square duct opening to 14" round duct opening.

ROOF CURBS - NRCA approved curbs provide proper fit to base unit for rooftop installations. Curbs are designed to be assembled through hinge pins in each corner. Kit also provides seal strip to assure a water tight seal. 8 and 14 inch high roof curbs are available.

MANUAL OUTDOOR DAMPER - Provides 0% through 50% outdoor air capability (field adjustable). Designed for duct mounted side supply/return applications. Includes hood and screen assembly.

WALL THERMOSTAT - The units are designed to operate with 24-volt electronic and electro-mechanical thermostats. All units can operate with single stage heat / single stage cool thermostats - with or without the economizer.

LOW AMBIENT KIT - Kit provides necessary hardware to convert unit to operate in cooling cycle down to 0 F. Standard unit operation 45 F.

TRANSFORMER KIT - Kit provides necessary hardware to provide single phase models from factory furnished 40 VA transformer capability to 75 VA transformer capability. (Required on installations with economizer or motorized damper.)

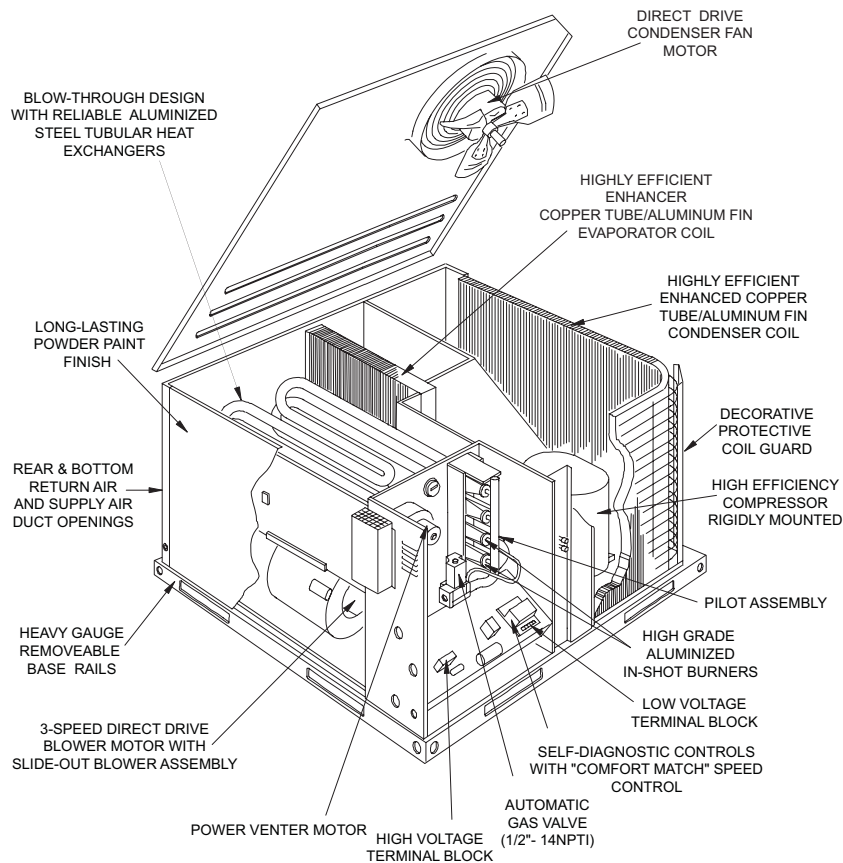

FIGURE 2 - UNIT COMPONENT LOCATION

TABLE 1: PHYSICAL DATA

MODEL		DNA				
		030	036	042	048	060
EVAPORATOR BLOWER	CENTRIFUGAL BLOWER (Dia. x W. in.)	10 x 8	11 x 10	11 x 10	12 x 11	12 x 11
	FAN MOTOR HP (3 Speed)	1/2	3/4	3/4	1	1
EVAPORATOR COIL	ROWS DEEP	2	2	3	3	3
	FINS PER INCH	13	15	13	13	13
	FACE AREA (Sq. Ft.)	3.5	3.5	3.5	4.5	4.5
CONDENSER FAN	PROPELLER DIA. (in.)	22	22	22	22	22
	FAN MOTOR HP	1/4	1/4	1/4	1/4	1/4
	NOM. CFM TOTAL	2,400	2,400	2,400	3,000	3,000
CONDENSER COIL	ROWS DEEP	1	1	1	1	1
	FINS PER INCH	16	20	20	20	20
	FACE AREA (Sq. Ft.)	11.7	11.7	11.7	14.8	14.8
CHARGE	REFRIGERANT 22 (lbs./oz.)	4 / 12	4 / 3	4 / 9	6 / 0	5 / 4
FILTER ¹	FACE AREA (Sq. Ft.) Size (Nominal)	2.6/20x20	2.6/20x20	2.6/20x20	3.3/20x12	3.3/20x12
FURNACE SECTION	NATURAL GAS BURNER ORIFICE NO. (Drill Size)	43	43	43	40	40
	PROPANE BURNER ORIFICE NO. (Drill Size)	55	55	55	53	53
	GAS CONNECTION SIZE	1/2 NPTI	1/2 NPTI	1/2 NPTI	1/2 NPTI	1/2 NPTI
COMPRESSOR TYPE	HERMETICALLY SEALED (R = RECIPROCATING, S = SCROLL)	R	R	R	S	S

1. See FILTER/FRAME KIT on page 5.

TABLE 2: RATINGS COOLING/GAS HEATING

MODEL DNA	NET COOLING CAPACITY ¹		SOUND RATING (dbels) ²	GAS HEAT CAPACITY / EFFICIENCIES				
	MBH	EER ³		INPUT (MBH)	OUTPUT (MBH)	AFUE ⁴ (%)	NUMBER OF BURNERS	TEMP. RISE (°F) RANGE
030N03606	29	9	78	45	36	80.2	2	25 - 55
030N05606	29	9	78	70	56	80.2	3	30 - 60
036N03606	34.8	8.9	82	45	36	80.4	2	25 - 55
036N05606	34.8	8.9	82	70	56	80.2	3	25 - 55
036N07206	34.8	8.9	82	90	72	80.1	4	30 - 60
036N03625	34.8	8.9	82	45	36	80.4	2	25 - 55
036N03646	34.8	8.9	82	45	36	80.4	2	25 - 55
036N05625	34.8	8.9	82	70	56	80.2	3	25 - 55
036N05646	34.8	8.9	82	70	56	80.2	3	25 - 55
036N07225	34.8	8.9	82	90	72	80.1	4	30 - 60
036N07246	34.8	8.9	82	90	72	80.1	4	30 - 60
042N03606	40.5	9	84	45	36	80.4	2	25 - 55
042N05606	40.5	9	84	70	56	80.2	3	25 - 55
042N07206	40.5	9	84	90	72	80.1	4	30 - 60
042N03625	40.5	9	84	45	36	80.4	2	25 - 55
042N03646	40.5	9	84	45	36	80.4	2	25 - 55
042N05625	40.5	9	84	70	56	80.2	3	25 - 55
042N05646	40.5	9	84	70	56	80.2	3	25 - 55
042N07225	40.5	9	84	90	72	80.1	4	30 - 60
042N07246	40.5	9	84	90	72	80.1	4	30 - 60
048N06506	46.5	8.6	82	80	64	80	3	25 - 55
048N09006	46.5	8.6	82	108	86	80	4	30 - 60
048N11006	46.5	8.6	82	135	108	80	5	35 - 65
048N06525	46.5	8.6	82	80	64	80	3	25 - 55
048N06546	46.5	8.6	82	80	64	80	3	25 - 55
048N09025	46.5	8.6	82	108	86	80	4	30 - 60
048N09046	46.5	8.6	82	108	86	80	4	30 - 60
048N11025	46.5	8.6	82	135	108	80	5	35 - 65
048N11046	46.5	8.6	82	135	108	80	5	35 - 65
060N06506	56.5	8.9	82	80	64	80	3	25 - 55
060N09006	56.5	8.9	82	108	86	80	4	30 - 60
060N11006	56.5	8.9	82	135	108	80	5	35 - 65
060N06525	56.5	8.9	82	80	64	80	3	25 - 55
060N06546	56.5	8.9	82	80	64	80	3	25 - 55
060N09025	56.5	8.9	82	108	86	80	4	30 - 60
060N09046	56.5	8.9	82	108	86	80	4	30 - 60
060N11025	56.5	8.9	82	135	108	80	5	35 - 65
060N11046	56.5	8.9	82	135	108	80	5	35 - 65

1. Net Cooling Capacity = ARI 210 standard rating conditions.

2. (dbels) = ARI 270-95

3. Energy Efficiency Ratio - the total cooling output in BTU's during a normal annual usage period for cooling divided by the total electric power input in watt-hours during the same period.

4. AFUE = Annual Fuel Utilization Efficiency.

TABLE 3: DNA030 COOLING CAPACITIES - 2-1/2 TON

TEMPERATURE OF AIR ON CONDENSER COIL		AIR ON EVAPORATOR COIL																					
		750 CFM				875 CFM				1,000 CFM				1,125 CFM				1,250 CFM					
		WB °F				WB °F				WB °F				WB °F				WB °F					
		72	67	62	57	72	67	62	57	72	67	62	57	72	67	62	57	72	67	62	57		
85 °F	NET CAP. MBH	28.1	26.4	24.2	22.6	30.6	28.7	26.3	24.5	32.9	31.0	28.3	26.4	33.2	31.2	28.6	26.7	33.5	31.5	28.8	26.9		
	TOTAL POWER INPUT kW	2.99	2.95	2.90	2.89	3.03	2.99	2.94	2.93	3.06	3.02	2.97	2.96	3.13	3.09	3.04	3.03	3.20	3.16	3.11	3.10		
	Sensible Capacity MBH ¹	Entering Dry Bulb °F	86	15.3	19.8	23.6	22.6	18.6	23.6	26.0	24.5	21.9	27.4	28.3	26.4	21.1	26.8	28.6	26.7	20.2	26.2	28.8	26.9
			83	14.5	19.0	22.8	21.9	17.0	21.9	25.6	24.2	19.4	24.9	28.3	26.4	19.3	25.1	28.6	26.7	19.3	25.2	28.8	26.9
			80	13.7	18.2	22.1	21.2	15.3	20.3	24.6	23.6	16.9	22.4	27.2	26.1	17.6	23.3	28.0	26.5	18.3	24.2	28.8	26.9
			77	13.0	17.4	21.3	20.4	13.7	18.7	23.0	22.0	14.5	20.0	24.7	23.6	15.9	21.6	26.3	24.8	17.3	23.3	27.8	25.9
			74	12.2	16.7	20.5	19.6	12.1	17.1	21.4	20.4	12.0	17.5	22.2	21.1	14.2	19.9	24.6	23.0	16.4	22.3	26.9	24.9
			71	-	15.9	19.7	18.8	-	15.5	19.8	18.7	-	15.0	19.8	18.7	-	18.2	22.8	21.3	-	21.3	25.9	24.0
68	-	15.1	19.0	18.1	-	13.8	18.1	17.1	-	12.6	17.3	16.2	-	16.5	21.1	19.6	-	20.4	24.9	23.0			
95 °F	NET CAP. MBH	26.8	25.0	22.3	21.4	29.2	27.3	24.3	23.4	31.7	29.6	26.4	25.4	32.0	29.9	26.6	25.6	32.2	30.1	26.8	25.8		
	TOTAL POWER INPUT kW	3.18	3.14	3.08	3.07	3.22	3.18	3.11	3.11	3.26	3.22	3.15	3.15	3.34	3.30	3.23	3.22	3.42	3.38	3.30	3.30		
	Sensible Capacity MBH ¹	Entering Dry Bulb °F	86	17.9	22.3	22.3	21.4	19.9	24.9	24.3	23.4	22.0	27.5	26.4	25.4	21.0	26.7	26.6	25.6	19.9	25.9	26.8	25.8
			83	15.6	20.1	22.3	21.4	17.5	22.5	24.3	23.4	19.3	24.9	26.4	25.4	19.1	24.9	26.6	25.6	19.0	24.9	26.8	25.8
			80	13.4	17.8	21.0	20.0	15.0	20.0	23.6	22.4	16.6	22.2	26.1	24.8	17.3	23.1	26.5	25.3	18.0	24.0	26.8	25.8
			77	11.1	15.6	18.8	17.7	12.6	17.5	21.1	19.9	14.0	19.5	23.5	22.2	15.5	21.2	24.6	23.5	17.0	23.0	25.8	24.8
			74	8.9	13.4	16.5	15.5	10.1	15.1	18.7	17.5	11.3	16.8	20.8	19.5	13.7	19.4	22.8	21.7	16.0	22.0	24.9	23.9
			71	-	11.1	14.3	13.3	-	12.6	16.2	15.0	-	14.1	18.1	16.8	-	17.6	21.0	19.8	-	21.0	23.9	22.9
68	-	8.9	12.1	11.0	-	10.2	13.7	12.6	-	11.5	15.4	14.1	-	15.8	19.2	18.0	-	20.1	22.9	21.9			
105 °F	NET CAP. MBH	25.4	23.0	20.6	20.1	27.7	25.0	22.5	21.9	30.0	27.1	24.4	23.8	30.4	27.4	24.7	24.0	30.7	27.8	25.0	24.3		
	TOTAL POWER INPUT kW	2.94	3.31	3.23	3.24	2.98	3.36	3.28	3.29	3.03	3.41	3.33	3.34	3.10	3.49	3.41	3.42	3.17	3.57	3.48	3.49		
	Sensible Capacity MBH ¹	Entering Dry Bulb °F	86	15.9	20.0	20.6	20.1	17.7	22.3	22.5	21.9	19.6	24.7	24.4	23.8	19.5	24.9	24.7	24.0	19.5	25.1	25.0	24.3
			83	14.4	18.5	20.5	19.9	16.1	20.7	22.5	21.8	17.8	22.9	24.4	23.8	18.2	23.5	24.7	24.0	18.6	24.1	25.0	24.3
			80	13.0	17.1	19.6	18.8	14.5	19.1	21.9	21.0	16.1	21.2	24.3	23.3	16.9	22.2	24.6	23.8	17.6	23.2	25.0	24.3
			77	11.5	15.6	18.1	17.3	12.9	17.5	20.3	19.5	14.4	19.5	22.5	21.6	15.5	20.9	23.3	22.5	16.7	22.2	24.0	23.4
			74	10.1	14.2	16.6	15.9	11.3	15.9	18.7	17.9	12.6	17.7	20.8	19.8	14.2	19.5	21.9	21.1	15.7	21.3	23.1	22.4
			71	-	12.7	15.2	14.4	-	14.3	17.1	16.3	-	16.0	19.0	18.1	-	18.2	20.6	19.8	-	20.4	22.1	21.5
68	-	11.3	13.7	13.0	-	12.7	15.5	14.7	-	14.2	17.3	16.3	-	16.8	19.2	18.4	-	19.4	21.2	20.6			
115 °F	NET CAP. MBH	24.1	20.9	19.0	18.8	26.2	22.8	20.7	20.5	28.3	24.6	22.4	22.1	28.8	25.0	22.7	22.5	29.2	25.4	23.1	22.8		
	TOTAL POWER INPUT kW	2.70	3.47	3.38	3.40	2.75	3.53	3.44	3.47	2.80	3.60	3.50	3.53	2.86	3.68	3.58	3.61	2.92	3.76	3.66	3.69		
	Sensible Capacity MBH ¹	Entering Dry Bulb °F	86	13.9	17.7	19.0	18.8	15.5	19.7	20.7	20.5	17.2	21.8	22.4	22.1	18.1	23.0	22.7	22.5	19.1	24.2	23.1	22.8
			83	13.2	17.0	18.8	18.3	14.8	19.0	20.6	20.2	16.4	21.0	22.4	22.1	17.3	22.2	22.7	22.5	18.2	23.3	23.1	22.8
			80	12.6	16.3	18.1	17.6	14.1	18.3	20.2	19.7	15.6	20.2	22.4	21.8	16.4	21.3	22.7	22.3	17.3	22.4	23.1	22.8
			77	11.9	15.7	17.4	16.9	13.3	17.5	19.5	19.0	14.8	19.4	21.6	21.0	15.6	20.5	21.9	21.5	16.3	21.5	22.2	21.9
			74	11.2	15.0	16.7	16.3	12.6	16.8	18.8	18.2	13.9	18.6	20.8	20.2	14.7	19.6	21.0	20.6	15.4	20.6	21.3	21.0
			71	-	14.3	16.1	15.6	-	16.1	18.0	17.5	-	17.8	20.0	19.4	-	18.7	20.2	19.7	-	19.7	20.4	20.1
68	-	13.6	15.4	14.9	-	15.3	17.3	16.7	-	17.0	19.2	18.6	-	17.9	19.3	18.9	-	18.8	19.5	19.2			
125 °F	NET CAP. MBH	22.7	18.9	17.4	17.5	24.7	20.5	18.9	19.0	26.6	22.2	20.4	20.5	27.2	22.6	20.8	20.9	27.7	23.1	21.3	21.4		
	TOTAL POWER INPUT kW	2.45	3.63	3.53	3.57	2.51	3.71	3.60	3.64	2.56	3.79	3.68	3.72	2.62	3.87	3.76	3.80	2.68	3.96	3.84	3.89		
	Sensible Capacity MBH ¹	Entering Dry Bulb °F	86	11.9	15.3	17.4	17.5	13.3	17.2	18.9	19.0	14.7	19.0	20.4	20.5	16.7	21.2	20.8	20.9	18.9	23.4	21.3	21.4
			83	12.0	15.5	17.0	16.7	13.5	17.3	18.7	18.6	14.9	19.1	20.4	20.5	16.3	20.8	20.8	20.9	17.8	22.5	21.3	21.4
			80	12.2	15.6	16.6	16.4	13.6	17.4	18.6	18.3	15.0	19.2	20.5	20.2	16.0	20.4	20.9	20.8	16.9	21.7	21.3	21.4
			77	12.3	15.7	16.7	16.5	13.7	17.5	18.7	18.5	15.1	19.4	20.7	20.4	15.6	20.1	20.5	20.4	16.0	20.8	20.4	20.5
			74	12.4	15.8	16.9	16.8	13.8	17.6	18.8	18.6	15.3	19.5	20.8	20.5	15.2	19.7	20.1	20.1	15.1	19.9	19.5	19.6
			71	-	15.9	17.0	16.7	-	17.8	18.9	18.7	-	19.6	20.9	20.7	-	19.3	19.8	19.7	-	19.0	18.6	18.7
68	-	16.0	17.1	16.9	-	17.9	19.1	18.8	-	19.8	21.1	20.8	-	19.0	19.4	19.3	-	18.1	17.7	17.8			

1. These capacities are net capacities (the indoor fan heat is deducted). ALL SENSIBLE CAPACITY

TABLE 4: DNA036 COOLING CAPACITIES - 3 TON

TEMPERATURE OF AIR ON CONDENSER COIL		AIR ON EVAPORATOR COIL																					
		900 CFM				1,050 CFM				1,200 CFM				1,350 CFM				1,500 CFM					
		WB °F				WB °F				WB °F				WB °F				WB °F					
		72	67	62	57	72	67	62	57	72	67	62	57	72	67	62	57	72	67	62	57		
85 °F	NET CAP. MBH	36.7	34.6	31.9	30.3	37.9	35.7	32.9	31.3	39.1	36.9	34.0	32.3	39.4	37.1	34.2	32.5	39.6	37.4	34.4	32.7		
	TOTAL POWER INPUT kW	3.57	3.51	3.44	3.41	3.64	3.58	3.51	3.48	3.71	3.65	3.58	3.55	3.80	3.73	3.66	3.63	3.88	3.82	3.74	3.71		
	Sensible Capacity MBH¹	Entering Dry Bulb °F	86	19.8	25.2	29.9	30.3	23.0	28.7	32.0	31.3	26.1	32.1	34.0	32.3	24.8	31.0	34.2	32.5	23.5	29.9	34.4	32.7
			83	18.9	24.3	29.0	29.7	21.0	26.7	31.5	31.0	23.1	29.2	34.0	32.3	22.8	29.0	34.2	32.5	22.4	28.8	34.4	32.7
			80	18.0	23.4	28.1	28.8	19.1	24.8	29.8	30.5	20.1	26.2	31.5	32.3	20.7	27.0	32.4	32.5	21.3	27.7	33.3	32.7
			77	17.1	22.4	27.2	27.9	17.1	22.8	27.8	28.6	17.2	23.2	28.5	29.3	18.7	24.9	30.4	30.5	20.2	26.6	32.2	31.6
			74	16.1	21.5	26.2	26.9	15.2	20.9	25.9	26.6	14.2	20.2	25.5	26.3	16.7	22.9	28.3	28.4	19.1	25.5	31.1	30.5
			71	-	20.6	25.3	26.0	-	18.9	23.9	24.7	-	17.3	22.6	23.4	-	20.9	26.3	26.4	-	24.4	30.0	29.4
			68	-	19.7	24.4	25.1	-	17.0	22.0	22.7	-	14.3	19.6	20.4	-	18.8	24.3	24.4	-	23.3	28.9	28.3
	95 °F	NET CAP. MBH	36.9	34.1	31.4	31.2	37.3	34.5	31.8	31.5	37.7	34.9	32.1	31.9	38.3	35.5	32.6	32.4	39.0	36.1	33.2	32.9	
		TOTAL POWER INPUT kW	3.77	3.73	3.64	3.61	3.86	3.81	3.72	3.69	3.95	3.90	3.81	3.77	4.03	3.98	3.88	3.85	4.11	4.06	3.96	3.93	
Sensible Capacity MBH¹		Entering Dry Bulb °F	86	23.8	29.2	31.4	31.2	25.1	30.8	31.8	31.5	26.5	32.4	32.1	31.9	25.1	31.2	32.6	32.4	23.6	30.0	33.2	32.9
			83	21.1	26.5	31.2	31.2	22.2	27.8	31.7	31.5	23.3	29.2	32.1	31.9	22.9	29.0	32.6	32.4	22.5	28.9	33.2	32.9
			80	18.4	23.8	28.5	29.3	19.2	24.9	29.8	30.6	20.0	26.0	31.1	31.9	20.7	26.9	32.1	32.4	21.4	27.8	33.2	32.9
			77	15.7	21.1	25.9	26.6	16.3	21.9	26.9	27.6	16.8	22.7	27.9	28.7	18.6	24.7	30.0	30.3	20.3	26.7	32.1	31.8
			74	13.0	18.5	23.2	23.9	13.3	19.0	23.9	24.7	13.6	19.5	24.7	25.5	16.4	22.5	27.8	28.1	19.2	25.6	31.0	30.7
			71	-	15.8	20.5	21.2	-	16.0	21.0	21.7	-	16.3	21.4	22.2	-	20.4	25.7	25.9	-	24.5	29.9	29.6
			68	-	13.1	17.8	18.5	-	13.1	18.0	18.8	-	13.1	18.2	19.0	-	18.2	23.5	23.8	-	23.4	28.8	28.5
105 °F		NET CAP. MBH	34.9	32.6	30.7	29.6	35.3	32.9	31.0	29.9	35.6	33.2	31.3	30.2	36.1	33.6	31.7	30.6	36.5	34.0	32.1	30.9	
		TOTAL POWER INPUT kW	4.00	3.93	3.84	3.83	4.09	4.01	3.93	3.91	4.18	4.10	4.01	3.99	4.26	4.18	4.09	4.07	4.34	4.26	4.17	4.15	
	Sensible Capacity MBH¹	Entering Dry Bulb °F	86	21.1	27.2	29.8	28.8	22.4	28.7	30.6	29.5	23.7	30.3	31.3	30.2	23.2	30.1	31.7	30.6	22.8	29.8	32.1	30.9
			83	19.4	25.4	29.3	28.4	20.5	26.8	30.3	29.3	21.6	28.2	31.3	30.2	21.6	28.5	31.7	30.6	21.7	28.7	32.1	30.9
			80	17.7	23.7	27.6	27.0	18.6	24.9	29.0	28.4	19.5	26.1	30.4	29.8	20.1	26.9	31.2	30.4	20.6	27.7	32.1	30.9
			77	15.9	21.9	25.8	25.3	16.6	23.0	27.1	26.5	17.4	24.0	28.3	27.7	18.5	25.3	29.7	28.8	19.6	26.6	31.0	29.8
			74	14.2	20.2	24.1	23.5	14.7	21.0	25.1	24.6	15.3	21.9	26.2	25.6	16.9	23.7	28.1	27.2	18.5	25.5	29.9	28.8
			71	-	18.4	22.3	21.8	-	19.1	23.2	22.7	-	19.8	24.1	23.5	-	22.2	26.5	25.6	-	24.5	28.9	27.7
			68	-	16.7	20.6	20.0	-	17.2	21.3	20.7	-	17.7	22.0	21.4	-	20.6	24.9	24.0	-	23.4	27.8	26.7
	115 °F	NET CAP. MBH	33.0	31.0	30.0	28.0	33.3	31.3	30.3	28.2	33.5	31.6	30.6	28.5	33.8	31.8	30.8	28.7	34.0	32.0	31.0	28.9	
		TOTAL POWER INPUT kW	4.24	4.13	4.05	4.04	4.32	4.22	4.13	4.12	4.41	4.30	4.22	4.21	4.50	4.38	4.30	4.29	4.58	4.47	4.38	4.37	
Sensible Capacity MBH¹		Entering Dry Bulb °F	86	18.5	25.1	28.2	26.4	19.7	26.7	29.4	27.4	20.9	28.2	30.6	28.5	21.4	28.9	30.8	28.7	21.9	29.6	31.0	28.9
			83	17.7	24.3	27.4	25.6	18.8	25.8	29.0	27.0	19.9	27.3	30.6	28.5	20.4	27.9	30.8	28.7	20.9	28.6	31.0	28.9
			80	16.9	23.5	26.6	24.8	17.9	24.9	28.1	26.2	18.9	26.3	29.7	27.7	19.4	26.9	30.3	28.3	19.9	27.6	31.0	28.9
			77	16.1	22.7	25.8	24.0	17.0	24.0	27.2	25.4	17.9	25.3	28.7	26.7	18.4	25.9	29.3	27.3	18.8	26.6	30.0	27.9
			74	15.3	21.9	24.9	23.2	16.1	23.1	26.4	24.5	17.0	24.3	27.8	25.8	17.4	24.9	28.3	26.3	17.8	25.5	28.9	26.8
			71	-	21.1	24.1	22.4	-	22.2	25.5	23.6	-	23.4	26.8	24.8	-	23.9	27.3	25.3	-	24.5	27.9	25.8
			68	-	20.3	23.3	21.6	-	21.3	24.6	22.7	-	22.4	25.8	23.8	-	22.9	26.3	24.3	-	23.5	26.9	24.8
125 °F		NET CAP. MBH	31.0	29.4	29.3	26.4	31.2	29.7	29.6	26.6	31.4	29.9	29.8	26.8	31.5	29.9	29.8	26.8	31.5	30.0	29.9	26.9	
		TOTAL POWER INPUT kW	4.47	4.33	4.26	4.26	4.55	4.42	4.34	4.34	4.64	4.50	4.42	4.42	4.73	4.59	4.51	4.51	4.82	4.68	4.59	4.60	
	Sensible Capacity MBH¹	Entering Dry Bulb °F	86	15.9	23.1	26.6	24.0	17.0	24.6	28.2	25.4	18.1	26.1	29.8	26.8	19.6	27.8	29.8	26.8	21.1	29.5	29.9	26.9
			83	16.0	23.2	25.4	22.8	17.1	24.8	27.6	24.8	18.2	26.3	29.8	26.8	19.1	27.4	29.8	26.8	20.1	28.5	29.9	26.9
			80	16.2	23.3	25.6	22.5	17.3	24.9	27.3	24.1	18.4	26.5	29.0	25.6	18.7	27.0	29.5	26.2	19.1	27.5	29.9	26.9
			77	16.3	23.5	25.7	22.7	17.4	25.0	27.4	24.2	18.5	26.6	29.2	25.8	18.3	26.6	29.0	25.8	18.1	26.5	28.9	25.9
			74	16.4	23.6	25.8	22.8	17.6	25.2	27.6	24.4	18.7	26.8	29.3	25.9	17.9	26.1	28.6	25.4	17.1	25.5	27.9	24.9
			71	-	23.7	26.0	22.9	-	25.3	27.7	24.5	-	26.9	29.5	26.1	-	25.7	28.2	25.0	-	24.5	26.9	23.9
			68	-	23.9	26.1	23.1	-	25.5	27.9	24.7	-	27.1	29.6	26.2	-	25.3	27.8	24.6	-	23.5	25.9	22.9

1. These capacities are net capacities (the indoor fan heat is deducted). ALL SENSIBLE CAPACITY

TABLE 5: DNA042 COOLING CAPACITIES - 3-1/2 TON

TEMPERATURE OF AIR ON CONDENSER COIL		AIR ON EVAPORATOR COIL																					
		1,050 CFM				1,225 CFM				1,400 CFM				1,575 CFM				1,750 CFM					
		WB °F				WB °F				WB °F				WB °F				WB °F					
		72	67	62	57	72	67	62	57	72	67	62	57	72	67	62	57	72	67	62	57		
85 °F	NET CAP. MBH	44.5	40.8	37.6	36.5	46.0	42.2	38.8	37.7	47.5	43.6	40.1	38.9	48.9	44.9	41.3	40.1	50.3	46.2	42.5	41.2		
	TOTAL POWER INPUT kW	4.01	4.00	3.85	3.85	4.16	4.15	4.00	4.00	4.31	4.31	4.15	4.15	4.36	4.35	4.19	4.19	4.40	4.39	4.23	4.23		
	Sensible Capacity MBH ¹	Entering Dry Bulb °F	86	23.6	29.7	35.1	35.9	27.6	34.2	37.6	37.4	31.6	38.6	40.1	38.9	31.0	38.5	41.3	40.1	30.5	38.4	42.5	41.2
		83	22.5	28.6	34.0	34.8	25.3	31.9	37.0	36.8	28.1	35.1	40.1	38.9	28.6	36.1	41.3	40.1	29.1	37.1	42.5	41.2	
		80	21.4	27.5	32.9	33.7	23.0	29.6	35.4	36.2	24.6	31.7	37.9	38.8	26.2	33.7	40.2	40.0	27.8	35.7	42.5	41.2	
		77	20.3	26.4	31.8	32.6	20.7	27.3	33.1	34.0	21.2	28.2	34.4	35.3	23.8	31.3	37.8	37.6	26.4	34.3	41.1	39.9	
		74	19.2	25.4	30.7	31.5	18.5	25.1	30.8	31.7	17.7	24.7	30.9	31.8	21.4	28.9	35.3	35.2	25.0	33.0	39.7	38.5	
71	-	24.3	29.7	30.4	-	22.8	28.6	29.4	-	21.3	27.5	28.4	-	26.4	32.9	32.8	-	31.6	38.4	37.2			
68	-	23.2	28.6	29.4	-	20.5	26.3	27.1	-	17.8	24.0	24.9	-	24.0	30.5	30.3	-	30.2	37.0	35.8			
95 °F	NET CAP. MBH	41.5	38.0	34.6	35.0	43.2	39.6	36.0	36.4	44.9	41.1	37.3	37.8	46.1	42.2	38.3	38.8	47.2	43.2	39.3	39.8		
	TOTAL POWER INPUT kW	4.24	4.22	4.07	4.10	4.40	4.38	4.22	4.25	4.56	4.54	4.38	4.40	4.62	4.60	4.43	4.46	4.68	4.66	4.49	4.52		
	Sensible Capacity MBH ¹	Entering Dry Bulb °F	86	26.5	32.7	34.6	35.0	29.0	35.7	36.0	36.4	31.4	38.7	37.3	37.8	30.3	38.0	38.3	38.8	29.2	37.3	39.3	39.8
		83	23.4	29.6	33.8	34.1	25.5	32.3	35.6	36.0	27.6	34.9	37.3	37.8	27.7	35.4	38.3	38.8	27.8	35.9	39.3	39.8	
		80	20.3	26.5	30.7	31.0	22.1	28.8	33.4	33.8	23.9	31.2	36.1	36.5	25.2	32.9	37.7	38.2	26.5	34.6	39.3	39.8	
		77	17.1	23.3	27.6	27.9	18.6	25.4	30.0	30.3	20.1	27.4	32.4	32.8	22.6	30.3	35.2	35.6	25.1	33.2	37.9	38.4	
		74	14.0	20.2	24.4	24.7	15.2	21.9	26.5	26.9	16.3	23.7	28.6	29.0	20.0	27.7	32.6	33.0	23.7	31.8	36.6	37.1	
71	-	17.1	21.3	21.6	-	18.5	23.1	23.4	-	19.9	24.9	25.2	-	25.2	30.0	30.5	-	30.4	35.2	35.7			
68	-	13.9	18.1	18.5	-	15.0	19.6	20.0	-	16.1	21.1	21.5	-	22.6	27.5	27.9	-	29.1	33.8	34.3			
105 °F	NET CAP. MBH	38.7	34.7	32.2	33.0	40.3	36.1	33.5	34.3	41.8	37.5	34.8	35.6	42.8	38.4	35.6	36.5	43.8	39.2	36.5	37.3		
	TOTAL POWER INPUT kW	4.51	4.44	4.34	4.34	4.67	4.59	4.49	4.49	4.82	4.74	4.63	4.64	4.90	4.82	4.71	4.71	4.98	4.90	4.78	4.79		
	Sensible Capacity MBH ¹	Entering Dry Bulb °F	86	23.6	29.4	31.7	31.8	25.7	32.0	33.3	33.7	27.8	34.6	34.8	35.6	28.0	35.1	35.6	36.4	28.1	35.7	36.5	37.3
		83	21.5	27.3	30.9	30.9	23.4	29.7	32.9	32.9	25.3	32.1	34.8	35.0	26.1	33.2	35.6	36.2	26.8	34.4	36.5	37.3	
		80	19.5	25.3	28.9	28.8	21.2	27.5	31.4	31.3	22.9	29.7	33.8	33.8	24.2	31.3	35.2	35.5	25.5	33.0	36.5	37.3	
		77	17.5	23.3	26.8	26.8	18.9	25.2	29.1	29.1	20.4	27.2	31.4	31.4	22.3	29.5	33.3	33.7	24.1	31.7	35.1	36.0	
		74	15.4	21.2	24.8	24.7	16.7	23.0	26.9	26.8	18.0	24.8	28.9	28.9	20.4	27.6	31.4	31.8	22.8	30.4	33.8	34.6	
71	-	19.2	22.7	22.7	-	20.7	24.6	24.6	-	22.3	26.5	26.5	-	25.7	29.5	29.9	-	29.0	32.5	33.3			
68	-	17.1	20.7	20.7	-	18.5	22.4	22.3	-	19.9	24.0	24.0	-	23.8	27.6	28.0	-	27.7	31.1	32.0			
115 °F	NET CAP. MBH	35.9	31.3	29.9	30.9	37.3	32.6	31.1	32.2	38.8	33.9	32.3	33.4	39.6	34.5	33.0	34.1	40.3	34.2	33.6	34.8		
	TOTAL POWER INPUT kW	4.78	4.66	4.61	4.59	4.93	4.80	4.75	4.73	5.08	4.95	4.89	4.87	5.18	5.04	4.99	4.97	5.27	5.14	5.08	5.06		
	Sensible Capacity MBH ¹	Entering Dry Bulb °F	86	20.6	26.0	28.9	28.5	22.4	28.2	30.6	31.0	24.2	30.4	32.3	33.4	25.6	32.3	33.0	34.1	27.1	34.1	33.6	34.8
		83	19.7	25.1	28.0	27.6	21.4	27.2	30.1	29.9	23.0	29.3	32.3	32.2	24.4	31.0	33.0	33.5	25.8	32.8	33.6	34.8	
		80	18.7	24.1	27.0	26.6	20.3	26.1	29.3	28.9	21.9	28.2	31.6	31.1	23.2	29.8	32.6	32.9	24.5	31.5	33.6	34.8	
		77	17.8	23.2	26.1	25.7	19.3	25.1	28.2	27.8	20.7	27.0	30.4	30.0	22.0	28.6	31.4	31.7	23.2	30.2	32.3	33.5	
		74	16.9	22.2	25.1	24.8	18.2	24.0	27.2	26.8	19.6	25.9	29.3	28.8	20.8	27.4	30.1	30.5	21.9	28.9	31.0	32.2	
71	-	21.3	24.2	23.8	-	23.0	26.2	25.7	-	24.7	28.1	27.7	-	26.2	28.9	29.3	-	27.6	29.7	30.9			
68	-	20.3	23.2	22.9	-	22.0	25.1	24.7	-	23.6	27.0	26.5	-	25.0	27.7	28.1	-	26.4	28.5	29.6			
125 °F	NET CAP. MBH	33.0	27.9	27.5	28.9	34.4	29.1	28.7	30.1	35.8	30.3	29.8	31.3	36.3	30.7	30.3	31.7	36.9	31.2	30.7	32.2		
	TOTAL POWER INPUT kW	5.05	4.88	4.87	4.83	5.19	5.02	5.01	4.97	5.34	5.16	5.15	5.11	5.45	5.27	5.26	5.22	5.57	5.38	5.37	5.33		
	Sensible Capacity MBH ¹	Entering Dry Bulb °F	86	17.7	22.6	26.1	25.3	19.1	24.5	27.9	28.2	20.6	26.3	29.8	31.2	23.3	29.4	30.3	31.7	26.0	32.5	30.7	32.2
		83	17.8	22.8	25.0	24.3	19.3	24.6	27.4	26.9	20.7	26.5	29.8	29.5	22.7	28.8	30.3	30.8	24.8	31.2	30.7	32.2	
		80	18.0	22.9	25.2	24.4	19.4	24.8	27.2	26.4	20.9	26.6	29.3	28.4	22.2	28.3	30.0	30.3	23.5	30.0	30.7	32.2	
		77	18.1	23.1	25.3	24.6	19.6	24.9	27.4	26.6	21.1	26.8	29.4	28.6	21.7	27.8	29.5	29.8	22.3	28.7	29.5	31.0	
		74	18.3	23.2	25.5	24.8	19.8	25.1	27.5	26.7	21.2	27.0	29.6	28.7	21.1	27.2	28.9	29.2	21.0	27.5	28.2	29.7	
71	-	23.4	25.6	24.9	-	25.3	27.7	26.9	-	27.2	29.8	28.9	-	26.7	28.4	28.7	-	26.2	27.0	28.5			
68	-	23.5	25.8	25.1	-	25.4	27.9	27.1	-	27.3	29.9	29.1	-	26.2	27.9	28.2	-	25.0	25.8	27.2			

1. These capacities are net capacities (the indoor fan heat is deducted). ALL SENSIBLE CAPACITY

TABLE 6: DNA048 COOLING CAPACITIES - 4 TON

TEMPERATURE OF AIR ON CONDENSER COIL		AIR ON EVAPORATOR COIL																				
		1,200 CFM				1,400 CFM				1,600 CFM				1,800 CFM				2,000 CFM				
		WB °F				WB °F				WB °F				WB °F				WB °F				
		72	67	62	57	72	67	62	57	72	67	62	57	72	67	62	57	72	67	62	57	
85 °F	NET CAP. MBH		48.5	45.0	41.0	41.6	49.9	46.3	42.2	42.8	51.3	47.6	43.4	44.0	52.4	48.7	44.4	44.9	53.5	49.7	45.3	45.9
	TOTAL POWER INPUT kW		3.99	3.93	3.87	3.86	4.01	3.95	3.88	3.88	4.02	3.96	3.90	3.89	4.04	3.97	3.91	3.91	4.05	3.99	3.92	3.92
	Sensible Capacity MBH ¹	86	28.9	36.8	41.0	41.6	31.9	40.5	42.2	42.8	34.9	44.1	43.4	44.0	38.0	46.9	44.4	44.9	41.0	49.7	45.3	45.9
		83	25.5	33.4	40.3	41.2	27.8	36.4	41.9	42.6	30.2	39.4	43.4	44.0	32.7	42.5	44.4	44.9	35.1	45.6	45.3	45.9
		80	22.0	30.0	36.9	37.8	23.8	32.4	39.8	40.9	25.6	34.8	42.8	43.9	27.3	37.2	44.1	44.9	29.1	39.6	45.3	45.9
		77	18.6	26.5	33.4	34.4	19.8	28.3	35.8	36.8	20.9	30.1	38.1	39.2	22.0	31.9	38.7	39.6	23.1	33.6	39.4	40.0
		74	15.2	23.1	30.0	31.0	15.7	24.3	31.7	32.8	16.2	25.4	33.5	34.6	16.7	26.6	33.4	34.3	17.2	27.7	33.4	34.0
		71	-	19.7	26.6	27.6	-	20.2	27.7	23.7	-	20.8	28.8	29.9	-	21.2	28.1	29.0	-	21.7	27.5	28.0
68	-	16.3	23.2	24.1	-	16.2	23.7	24.7	-	16.1	24.1	25.2	-	15.9	22.8	23.7	-	15.7	21.5	22.1		
95 °F	NET CAP. MBH		43.5	41.9	36.3	36.9	46.1	44.4	38.6	39.1	48.8	47.0	40.8	41.4	48.6	46.8	40.6	41.2	48.3	46.5	40.4	40.9
	TOTAL POWER INPUT kW		4.44	4.34	4.32	4.32	4.44	4.34	4.32	4.32	4.43	4.33	4.31	4.47	4.37	4.37	4.35	4.35	4.50	4.41	4.38	4.39
	Sensible Capacity MBH ¹	86	27.2	35.6	36.3	36.9	30.7	40.1	38.6	39.1	34.3	44.7	40.8	41.4	36.8	45.6	40.6	41.2	39.2	46.5	40.4	40.9
		83	23.7	32.2	36.3	36.9	26.7	36.1	38.6	39.1	29.7	40.0	40.8	41.4	31.5	42.3	40.6	41.2	33.3	44.6	40.4	40.9
		80	20.3	28.8	33.1	33.6	22.7	32.1	36.9	37.4	25.0	35.4	40.7	41.3	26.2	37.0	40.5	41.1	27.3	38.6	40.4	40.9
		77	16.9	25.3	29.7	30.2	18.6	28.0	32.9	33.4	20.3	30.7	36.1	36.6	20.8	31.7	35.2	35.8	21.3	32.7	34.4	35.0
		74	13.5	21.9	26.3	26.7	14.6	24.0	28.8	29.3	15.7	26.0	31.4	32.0	15.5	26.4	29.9	30.5	15.4	26.7	28.4	29.0
		71	-	18.5	22.8	23.3	-	19.9	24.8	25.3	-	21.4	26.7	27.3	-	21.1	24.6	25.2	-	20.8	22.5	23.0
68	-	15.1	19.4	19.5	-	15.9	20.7	21.3	-	16.7	22.1	22.6	-	15.7	19.3	19.9	-	14.8	16.5	17.1		
105 °F	NET CAP. MBH		42.2	39.2	35.7	36.0	44.1	40.9	37.2	37.5	45.9	42.6	38.8	39.1	46.4	43.1	39.2	39.5	47.0	43.6	39.7	40.0
	TOTAL POWER INPUT kW		4.94	4.85	4.81	4.81	4.95	4.85	4.81	4.82	4.95	4.86	4.82	4.83	4.98	4.89	4.84	4.85	5.00	4.91	4.87	4.89
	Sensible Capacity MBH ¹	86	26.7	34.8	35.7	36.0	30.1	38.1	37.2	37.5	33.4	41.5	38.8	39.1	36.1	42.5	39.2	39.5	38.8	43.6	39.7	40.0
		83	23.3	31.3	35.3	35.6	26.0	34.9	37.0	37.3	28.7	38.4	38.8	39.1	30.8	40.5	39.2	39.5	32.8	42.6	39.7	40.0
		80	19.9	27.9	32.0	32.2	22.0	30.8	35.3	35.6	24.1	33.8	38.7	39.0	25.5	35.7	39.2	39.5	26.9	37.7	39.7	40.0
		77	16.5	24.5	28.6	28.8	17.9	26.8	31.3	31.6	19.4	29.1	34.0	34.3	20.2	30.4	33.9	34.2	20.9	31.7	33.7	34.0
		74	13.0	21.1	25.1	25.4	13.9	22.8	27.2	27.5	14.7	24.4	29.4	29.7	14.8	25.1	28.6	28.9	14.9	25.8	27.8	28.1
		71	-	17.7	21.7	22.0	-	18.7	23.2	23.5	-	19.8	24.7	25.0	-	19.8	23.3	23.6	-	19.8	21.8	22.1
68	-	14.2	18.3	18.5	-	14.7	19.2	19.4	-	15.1	20.0	20.3	-	14.5	17.9	18.3	-	13.9	15.9	16.2		
115 °F	NET CAP. MBH		41.0	36.5	35.0	35.1	42.0	37.3	35.9	35.9	43.0	38.2	36.7	36.8	44.3	39.4	37.9	37.9	45.7	40.6	39.0	39.1
	TOTAL POWER INPUT kW		5.44	5.35	5.29	5.30	5.46	5.37	5.31	5.32	5.47	5.39	5.33	5.34	5.49	5.40	5.34	5.35	5.50	5.42	5.35	5.37
	Sensible Capacity MBH ¹	86	26.3	33.9	35.0	35.1	29.4	36.1	35.9	35.9	32.5	38.2	36.7	36.8	35.4	39.4	37.9	37.9	38.4	40.6	39.0	39.1
		83	22.9	30.5	34.3	34.3	25.3	33.7	35.5	35.5	27.8	36.9	36.7	36.8	30.1	38.7	37.9	37.9	32.4	40.6	39.0	39.1
		80	19.5	27.1	30.8	30.9	21.3	29.6	33.7	33.6	23.1	32.1	36.7	36.7	24.8	34.9	37.8	37.9	26.4	36.8	39.0	39.1
		77	16.0	23.7	27.4	27.5	17.2	25.6	29.7	29.8	18.5	27.5	32.0	32.0	19.5	29.2	32.5	32.6	20.5	30.8	33.1	33.1
		74	12.6	20.6	24.0	24.0	13.2	21.5	25.7	25.7	13.8	22.9	27.3	27.4	14.2	23.9	27.2	27.3	14.5	24.9	27.1	27.2
		71	-	16.8	20.6	20.6	-	17.5	21.6	21.7	-	18.2	22.7	22.7	-	18.5	21.9	22.0	-	18.9	21.1	21.2
68	-	13.4	17.2	17.2	-	13.5	17.6	17.6	-	13.5	18.0	18.1	-	13.2	16.6	16.6	-	12.9	15.2	15.2		
125 °F	NET CAP. MBH		39.7	33.7	34.3	34.2	39.9	33.6	34.5	34.3	40.1	33.9	34.7	34.5	42.2	35.8	36.5	36.3	44.4	37.7	38.4	38.2
	TOTAL POWER INPUT kW		5.90	5.90	5.80	5.80	6.00	5.90	5.80	5.80	6.00	5.90	5.80	5.90	6.00	5.90	5.80	5.90	6.00	5.90	5.80	5.90
	Sensible Capacity MBH ¹	86	25.9	33.1	34.3	34.2	28.7	34.0	34.5	34.3	31.5	35.0	34.7	34.5	34.7	36.4	36.5	36.3	37.9	37.7	38.4	38.2
		83	22.4	29.7	33.2	33.0	24.7	32.5	34.0	33.8	26.9	35.3	34.7	34.5	29.4	37.0	36.5	36.3	32.0	38.7	38.4	38.2
		80	19.0	26.2	29.7	29.5	20.6	28.4	32.2	32.0	22.2	30.6	34.6	34.4	24.1	33.2	36.5	36.3	26.0	35.9	38.4	38.2
		77	15.6	22.8	26.8	26.1	16.6	24.4	28.1	27.9	17.5	25.9	30.0	29.8	18.8	27.9	31.2	31.0	20.0	29.9	32.4	32.2
		74	12.2	19.4	22.9	22.7	12.5	20.3	24.1	23.9	12.9	21.3	25.3	25.1	13.5	22.6	25.9	25.7	14.1	23.9	26.4	26.2
		71	-	16.0	19.4	19.3	-	16.3	20.0	19.9	-	16.6	20.6	20.4	-	17.3	20.5	20.4	-	18.0	20.5	20.3
68	-	12.6	16.6	15.9	-	12.2	16.0	15.8	-	11.9	16.0	15.8	-	12.0	15.2	15.0	-	12.0	14.5	14.3		

1. These capacities are net capacities (the indoor fan heat is deducted). ALL SENSIBLE CAPACITY

TABLE 7: DNA060 COOLING CAPACITIES - 5 TON

TEMPERATURE OF AIR ON CONDENSER COIL		AIR ON EVAPORATOR COIL																					
		1,500 CFM				1,750 CFM				2,000 CFM				2,250 CFM				2,500 CFM					
		WB °F				WB °F				WB °F				WB °F				WB °F					
		72	67	62	57	72	67	62	57	72	67	62	57	72	67	62	57	72	67	62	57		
85 °F	NET CAP. MBH	60.3	56.2	52.0	51.1	62.4	58.1	53.8	52.9	64.4	60.0	55.5	54.6	65.4	60.9	56.4	55.5	66.5	61.8	57.3	56.3		
	TOTAL POWER INPUT kW	5.67	5.58	5.48	5.50	5.80	5.71	5.61	5.63	5.93	5.83	5.73	5.75	6.11	6.01	5.91	5.93	6.30	6.20	6.09	6.11		
	Sensible Capacity MBH ¹	Entering Dry Bulb °F	86	39.5	47.7	52.0	51.1	43.5	52.3	53.8	52.9	47.5	56.9	55.5	54.6	50.9	59.4	56.4	55.5	54.3	61.8	57.3	56.3
		83	35.2	43.4	50.6	50.9	38.4	47.2	53.1	52.7	41.6	51.0	55.5	54.6	44.3	54.1	56.4	55.5	46.9	57.2	57.3	56.3	
		80	31.0	39.1	46.4	46.6	33.4	42.2	50.0	50.2	35.8	45.2	53.6	53.9	37.6	47.5	55.4	55.1	39.4	49.8	57.3	56.3	
		77	26.7	34.8	42.1	42.3	28.3	37.1	44.9	45.2	30.0	39.4	47.8	48.1	31.0	40.9	48.8	48.5	32.0	42.3	49.8	48.9	
		74	22.4	30.5	37.8	38.0	23.3	32.0	39.9	40.1	24.2	33.6	42.0	42.2	24.3	34.2	42.2	41.8	24.5	34.9	42.4	41.4	
		71	-	26.3	33.5	33.8	-	27.0	34.8	35.1	-	27.7	36.1	36.4	-	27.6	35.5	35.2	17.1	27.4	34.9	34.0	
68	-	22.0	29.3	29.5	-	21.9	29.8	30.0	-	21.9	30.3	30.6	-	20.9	28.9	28.5	9.6	20.0	27.5	26.5			
95 °F	NET CAP. MBH	57.6	53.0	49.0	48.5	59.5	54.7	50.7	50.1	61.5	56.5	52.3	51.7	62.4	57.3	53.1	52.4	63.3	58.1	53.9	53.2		
	TOTAL POWER INPUT kW	6.14	6.11	5.96	6.01	6.30	6.27	6.11	6.16	6.45	6.42	6.26	6.32	6.62	6.59	6.43	6.49	6.80	6.76	6.60	6.65		
	Sensible Capacity MBH ¹	Entering Dry Bulb °F	86	37.6	46.8	49.0	48.5	41.5	51.4	50.7	50.1	45.3	56.0	52.3	51.7	48.6	57.1	53.1	52.4	51.8	58.1	53.9	53.2
		83	33.3	42.5	48.6	48.2	36.4	46.4	50.5	50.0	39.5	50.2	52.3	51.7	41.9	53.1	53.1	52.4	44.4	56.1	53.9	53.2	
		80	29.1	38.3	44.4	43.9	31.4	41.3	47.9	47.4	33.7	44.3	51.4	50.9	35.3	46.5	52.6	52.1	36.9	48.6	53.9	53.2	
		77	24.8	34.0	40.1	39.7	26.3	36.2	42.8	42.4	27.8	38.5	45.5	45.1	28.7	39.8	46.0	45.4	29.5	41.2	46.4	45.7	
		74	20.5	29.7	35.8	35.4	21.3	31.2	37.8	37.3	22.0	32.7	39.7	39.2	22.0	33.2	39.3	38.8	22.0	33.7	38.9	38.3	
		71	-	25.4	31.5	31.1	-	26.1	32.7	32.3	-	26.8	33.9	33.4	-	26.6	32.7	32.1	-	26.3	31.5	30.8	
68	-	21.2	27.2	26.8	-	21.1	27.6	27.2	-	21.0	28.0	27.6	-	19.9	26.0	25.5	-	18.8	24.0	23.4			
105 °F	NET CAP. MBH	53.0	48.8	45.0	42.7	55.0	50.7	46.8	44.3	57.1	52.5	48.5	45.9	57.6	53.1	49.0	46.4	58.2	53.6	49.5	46.9		
	TOTAL POWER INPUT kW	6.85	6.74	6.64	6.64	6.99	6.88	6.78	6.78	7.14	7.03	6.93	6.92	7.34	7.22	7.12	7.12	7.54	7.42	7.31	7.31		
	Sensible Capacity MBH ¹	Entering Dry Bulb °F	86	36.1	45.1	45.0	42.7	39.9	48.7	46.8	44.3	43.7	52.3	48.5	45.9	46.9	53.0	49.0	46.4	50.1	53.6	49.5	46.9
		83	31.8	40.8	44.8	42.6	34.9	44.6	46.7	44.2	37.9	48.4	48.5	45.9	40.3	50.5	49.0	46.4	42.6	52.6	49.5	46.9	
		80	27.6	36.5	41.5	39.4	29.8	39.5	44.9	42.6	32.1	42.5	48.3	45.8	33.6	44.6	48.9	46.3	35.2	46.6	49.5	46.9	
		77	23.3	32.2	37.2	35.1	24.8	34.5	39.8	37.5	26.3	36.7	42.4	40.0	27.0	37.9	42.2	39.7	27.7	39.2	42.0	39.4	
		74	19.0	28.0	32.9	30.8	19.7	29.4	34.8	32.5	20.4	30.9	36.6	34.2	20.3	31.3	35.6	33.1	20.3	31.7	34.6	32.0	
		71	-	23.7	28.6	26.5	-	24.4	29.7	27.4	-	25.0	30.8	28.3	-	24.6	29.0	26.4	-	24.2	27.1	24.5	
68	-	19.4	24.4	22.3	-	19.3	24.6	22.4	-	19.2	24.9	22.5	-	18.0	22.3	19.8	-	16.8	19.7	17.1			
115 °F	NET CAP. MBH	48.4	44.7	41.0	36.9	50.5	46.6	42.8	38.5	52.6	48.6	44.6	40.1	52.9	48.8	44.9	40.3	53.2	49.1	45.1	40.5		
	TOTAL POWER INPUT kW	7.56	7.37	7.33	7.27	7.69	7.50	7.46	7.40	7.82	7.63	7.59	7.53	8.05	7.85	7.81	7.75	8.28	8.08	8.03	7.97		
	Sensible Capacity MBH ¹	Entering Dry Bulb °F	86	34.6	43.3	41.0	36.9	38.4	45.9	42.8	38.5	42.2	48.6	44.6	40.1	45.2	48.8	44.9	40.3	48.3	49.1	45.1	40.5
		83	30.3	39.1	41.0	36.9	33.3	42.8	42.8	38.5	36.3	46.5	44.6	40.1	38.6	47.8	44.9	40.3	40.8	49.1	45.1	40.5	
		80	26.1	34.8	38.6	34.8	28.3	37.7	41.9	37.8	30.5	40.7	45.2	40.7	31.9	42.6	45.1	40.6	33.4	44.6	45.1	40.5	
		77	21.8	30.5	34.3	30.5	23.2	32.7	36.8	32.7	24.7	34.9	39.3	34.9	25.3	36.0	38.5	34.0	25.9	37.1	37.7	33.1	
		74	17.5	26.2	30.0	26.3	18.2	27.6	31.8	27.7	18.8	29.0	33.5	29.1	18.7	29.4	31.9	27.4	18.5	29.7	30.2	25.6	
		71	-	22.0	25.8	22.0	-	22.6	26.7	22.6	-	23.2	27.7	23.2	-	22.7	25.2	20.7	-	22.2	22.8	18.2	
68	-	17.7	21.5	17.7	-	17.5	21.7	17.6	-	17.4	21.8	17.4	-	16.1	18.6	14.1	-	14.8	15.3	10.7			
125 °F	NET CAP. MBH	43.8	40.5	37.1	31.1	46.0	42.6	38.9	32.7	48.2	44.6	40.7	34.3	48.2	44.6	40.8	34.2	48.2	44.6	40.8	34.2		
	TOTAL POWER INPUT kW	8.30	8.00	8.00	7.90	8.40	8.10	8.10	8.00	8.50	8.20	8.20	8.10	8.80	8.50	8.50	8.40	9.00	8.70	8.70	8.60		
	Sensible Capacity MBH ¹	Entering Dry Bulb °F	86	33.1	41.6	37.1	31.1	36.8	43.2	38.9	32.7	40.6	44.8	40.7	34.3	43.5	44.7	40.8	34.2	46.5	44.6	40.8	34.2
		83	28.8	37.3	37.3	31.2	31.8	41.0	39.0	32.7	34.7	44.7	40.7	34.3	36.9	45.2	40.8	34.2	39.1	45.6	40.8	34.2	
		80	24.5	33.0	35.7	30.2	26.7	36.0	38.9	32.9	28.9	38.9	42.0	35.6	30.3	40.7	41.4	34.9	31.6	42.5	40.8	34.2	
		77	20.3	28.8	31.4	26.0	21.7	30.9	33.8	27.9	23.1	33.1	36.2	29.8	23.6	34.1	34.8	28.3	24.2	35.1	33.3	26.8	
		74	16.0	24.5	27.1	21.7	16.6	25.9	28.8	22.8	17.2	27.2	30.4	24.0	17.0	27.4	28.1	21.6	16.7	27.6	25.9	19.3	
		71	-	20.2	22.9	17.4	-	20.8	23.7	17.8	-	21.4	24.6	18.2	-	20.8	21.5	15.0	-	20.2	18.4	11.9	
68	-	15.9	18.6	13.1	-	15.8	18.7	12.7	-	15.6	18.7	12.3	-	14.2	14.8	8.2	-	12.7	10.9	4.4			

1. These capacities are net capacities (the indoor fan heat is deducted). ALL SENSIBLE CAPACITY

TABLE 8: SIDE SUPPLY AIR BLOWER PERFORMANCE¹

MODEL # DNA	MTR SPD	EXTERNAL STAIC PRESSURE - IWG																					
		.10		.20		.30		.40		.50		.60		.70		.80		.90		1.00		1.10	
		CFM	WATTS	CFM	WATTS	CFM	WATTS	CFM	WATTS	CFM	WATTS	CFM	WATTS	CFM	WATTS	CFM	WATTS	CFM	WATTS	CFM	WATTS	CFM	WATTS
030	HI	-	-	-	-	1238	504	1165	484	1075	463	984	443	894	422	751	390	-	-	-	-	-	-
	MED	994	333	947	321	901	309	854	297	774	280	-	-	-	-	-	-	-	-	-	-	-	-
	LOW	-	-	-	-	-	-	-	-	-	-	-	-	-	-	-	-	-	-	-	-	-	-
036	HI	-	-	-	-	-	-	-	-	1465	712	1390	685	1315	657	1204	623	1093	588	982	554	-	-
	MED	1432	650	1381	628	1330	605	1279	583	1210	556	1140	529	1071	502	977	477	-	-	-	-	-	-
	LOW	1191	527	1149	510	1107	494	1065	477	1009	459	952	441	-	-	-	-	-	-	-	-	-	-
042	HI	-	-	1681	797	1610	768	1540	740	1465	712	1390	685	1315	657	1204	623	1093	588	-	-	-	-
	MED	1432	650	1381	628	1330	605	1279	583	1210	556	1140	529	-	-	-	-	-	-	-	-	-	-
	LOW	1191	527	1149	510	1107	494	1065	477	-	-	-	-	-	-	-	-	-	-	-	-	-	-
048,060	HI	-	-	-	-	-	-	1908	1023	1832	982	1737	938	1656	889	1348	789	1252	754	-	-	-	-
	MED	-	-	-	-	-	-	1773	894	1726	869	1674	852	1613	832	1339	731	-	-	-	-	-	-
	LOW	-	-	-	-	1672	841	1610	804	1542	773	-	-	-	-	-	-	-	-	-	-	-	-

1. Above data includes allowances for a dry evaporator coil, gas heat exchanger and no filters. For additional pressure drops, refer to Table 10 and 11.

TABLE 9: BOTTOM SUPPLY AIR BLOWER PERFORMANCE¹

MODEL # DNA	MTR SPD	EXTERNAL STATIC PRESSURE - IWG																					
		.10		.20		.30		.40		.50		.60		.70		.80		.90		1.00		1.10	
		CFM	WATTS	CFM	WATTS	CFM	WATTS	CFM	WATTS	CFM	WATTS	CFM	WATTS	CFM	WATTS	CFM	WATTS	CFM	WATTS	CFM	WATTS	CFM	WATTS
030	HI	-	-	-	-	1115	454	1049	436	967	417	886	398	805	380	676	351	-	-	-	-	-	-
	MED	895	300	853	289	811	278	769	267	697	252	-	-	-	-	-	-	-	-	-	-	-	-
	LOW	-	-	-	-	-	-	-	-	-	-	-	-	-	-	-	-	-	-	-	-	-	-
036	HI	-	-	-	-	-	-	-	-	1458	688	1377	663	1295	639	1147	600	999	561	-	-	-	-
	MED	1482	628	1428	613	1374	599	1320	584	1242	556	1163	528	1085	500	961	474	-	-	-	-	-	-
	LOW	1239	510	1184	496	1130	481	1075	467	998	448	922	428	-	-	-	-	-	-	-	-	-	-
042	HI	-	-	1687	763	1614	737	1540	712	1458	688	1377	663	1295	639	1147	600	-	-	-	-	-	-
	MED	1482	628	1428	613	1374	599	1320	584	1242	556	1163	528	1085	500	-	-	-	-	-	-	-	-
	LOW	1239	510	1184	496	1130	481	1075	467	-	-	-	-	-	-	-	-	-	-	-	-	-	-
048,060	HI	-	-	-	-	-	-	1928	1032	1844	994	1636	923	1515	888	1441	849	-	-	-	-	-	-
	MED	-	-	-	-	-	-	1805	837	1693	859	1580	819	1473	788	-	-	-	-	-	-	-	-
	LOW	-	-	-	-	1725	850	1660	807	1557	776	1428	728	-	-	-	-	-	-	-	-	-	-

1. Above data includes allowances for a dry evaporator coil, gas heat exchanger and no filters. For additional pressure drops, refer to Tables 10 and 11.

TABLE 10: ADDITIONAL STATIC PRESSURE RESISTANCE 2-1/2 - 3-1/2 TON (DNA030 - 042)¹

DESCRIPTION	RESISTANCE, IWG															
	CFM															
	500	600	700	800	900	1,000	1,100	1,200	1,300	1,400	1,500	1,600	1,700	1,800	1,900	2,000
WET EVAPORATOR COIL	.01	.01	.01	.02	.03	.04	.05	.06	.07	.08	.09	.09	-	-	-	-
ECONOMIZER ²	.00	.00	.00	.01	.01	.01	.01	.02	.03	.04	.05	.06	-	-	-	-
FILTER FRAME KIT	.01	.02	.04	.06	.08	.10	.13	.16	.17	.18	.19	.20	-	-	-	-

1. Deduct these resistance values from the available external static pressure shown in Tables 8 and 9.
2. The pressure through the economizer is greater for 100% outdoor air then for 100% return air. If the resistance of the return air duct system is less then 0.25 IWG, the unit will deliver less CFM during full economizer operation.

TABLE 11: ADDITIONAL STATIC PRESSURE RESISTANCE 4 - 5 TON (DNA048 - 060)¹

DESCRIPTION	RESISTANCE, IWG															
	CFM															
	500	600	700	800	900	1,000	1,100	1,200	1,300	1,400	1,500	1,600	1,700	1,800	1,900	2,000
WET EVAPORATOR COIL	-	-	-	-	-	-	-	.03	.04	.05	.06	.07	.07	.08	.09	.09
ECONOMIZER ²	-	-	-	-	-	-	-	.02	.02	.03	.03	.04	.04	.04	.05	.05
FILTER FRAME KIT	-	-	-	-	-	-	-	.04	.05	.05	.06	.07	.08	.09	.10	.11

1. Deduct these resistance values from the available external static pressure shown in Table 8 and 9.
2. The pressure through the economizer is greater for 100% outdoor air then for 100% return air. If the resistance of the return air duct system is less then 0.25 IWG, the unit will deliver less CFM during full economizer operation.

NOTE:
HEAT ANTICIPATOR
SHOULD BE SET AT 0.35
AMPS FOR ALL MODELS.

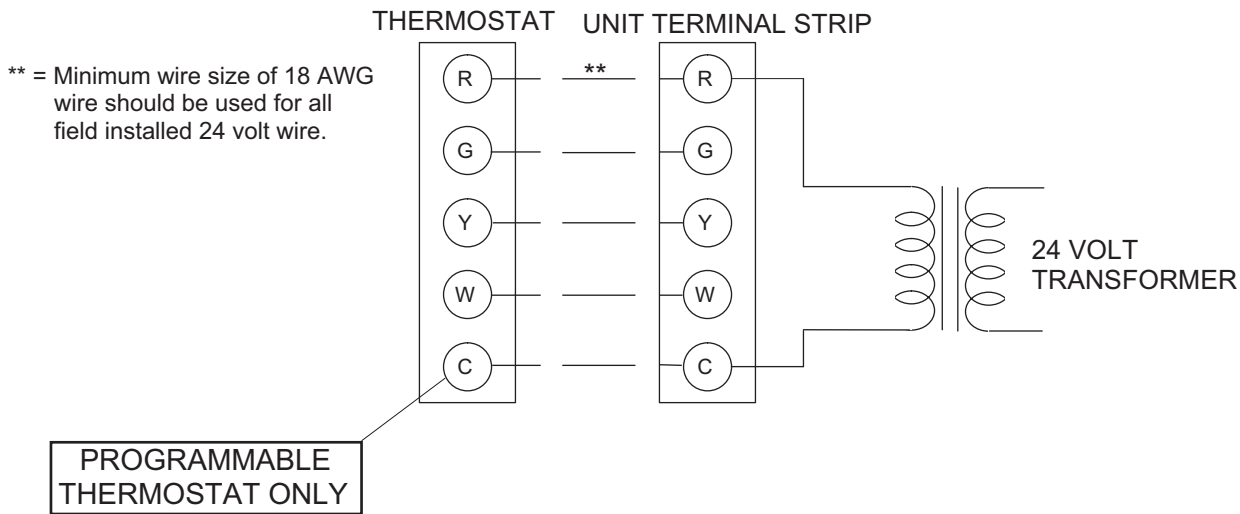

FIGURE 3 - TYPICAL FIELD CONTROL WIRING DIAGRAM

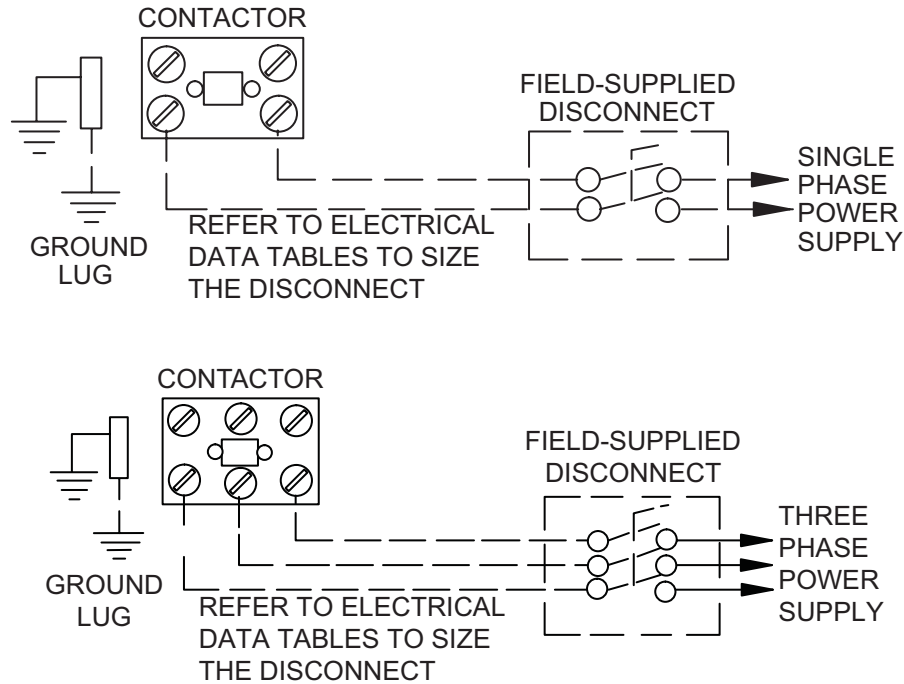

FIGURE 4 - TYPICAL FIELD POWER WIRING DIAGRAM

TABLE 12: ELECTRICAL DATA

MODEL DNA	POWER SUPPLY	VOLTAGE LIMITATIONS ¹		COMPRESSOR		COND. FAN MOTOR, FLA	SUPPLY AIR BLOWER MOTOR FLA	MINIMUM CIRCUIT AMPACITY	MAX. FUSE SIZE, AMPS ²	MAX. HACR BREAKER SIZE, AMPS	UNIT POWER FACTOR	TRANSFORMER SIZE (VA)
		MIN.	MAX.	RLA	LRA							
030	208/230-1-60	187	253	14.7	73	1.1	2.2	21.7	30	30	0.96	40
036	208/230-1-60	187	253	17.3	94	1.1	3.5	26.2	35	35	0.96	40
036	208/230-3-60	187	253	10.9	78	1.1	3.5	18.2	25	25	0.96	75
036	460-3-60	414	504	5.8	40	0.6	1.8	9.6	15	15	0.96	75
042	208/230-1-60	187	253	15.4	86	1.1	3.5	23.9	30	30	0.96	40
042	208/230-3-60	187	253	11.5	88	1.1	3.5	19	25	25	0.96	75
042	460-3-60	414	504	5.8	42	0.6	1.8	9.7	15	15	0.96	75
048	208/230-1-60	187	253	24.4	140	1.3	7	38.8	50	50	0.96	40
048	208/230-3-60	187	253	14.1	105	1.3	7	25.9	35	35	0.96	75
048	460-3-60	414	504	7.1	55	0.7	3.5	13.1	20	20	0.96	75
060	208/230-1-60	187	253	28.9	175	1.3	7	44.4	60	60	0.96	40
060	208/230-3-60	187	253	15.5	125	1.3	7	29.5	40	40	0.96	75
060	460-3-60	414	504	8.9	66.5	0.7	3.5	15.4	20	20	0.96	75

1. Utilization range "A" in accordance with ARI Standard 110.
2. Dual element, time delay type.

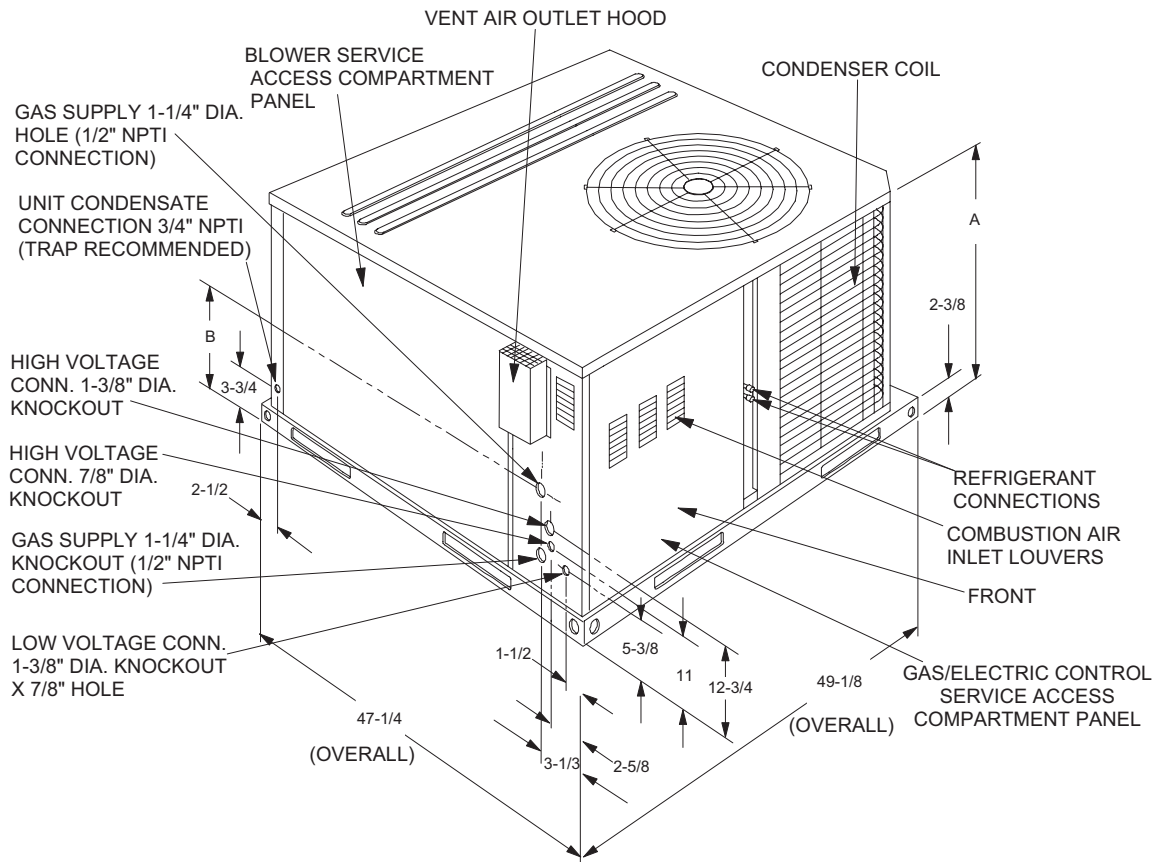

FIGURE 5 - UNIT DIMENSIONS - FRONT

TABLE 13: UNIT DIMENSIONS FRONT

UNIT SIZE	DIMENSION	
	"A"	"B"
030 thru 042	33-1/2	18-1/4
048 and 060	41-1/2	23-1/8

TABLE 14: UNIT MINIMUM CLEARANCES^{1 2}

CLEARANCES	
FRONT	36"
REAR	0"
LEFT SIDE (Filter-Access)	24"
RIGHT SIDE	12"
BELOW UNIT ³	0"
ABOVE UNIT ⁴	36" (For Condenser Air Discharge

1. A 1" clearance must be provided between any combustible material and the supply air ductwork.
2. The products of combustion must not be allowed to accumulate within a confined space and recirculate.
3. Units may be installed on combustible floors made from wood or class A, B, or C roof covering material.
4. Units must be installed outdoors. Overhanging structures or shrubs should not obstruct condenser air discharge outlet.

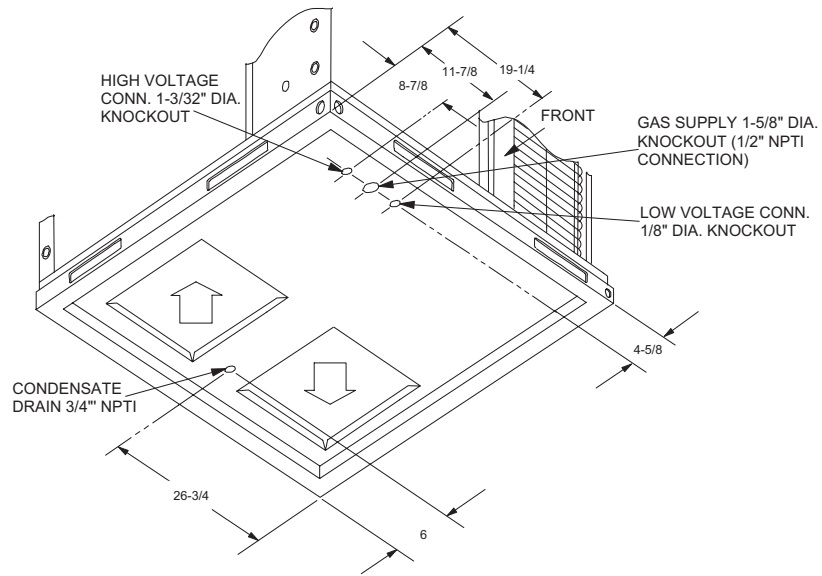

FIGURE 6 - UNIT DIMENSIONS - FRONT & BOTTOM

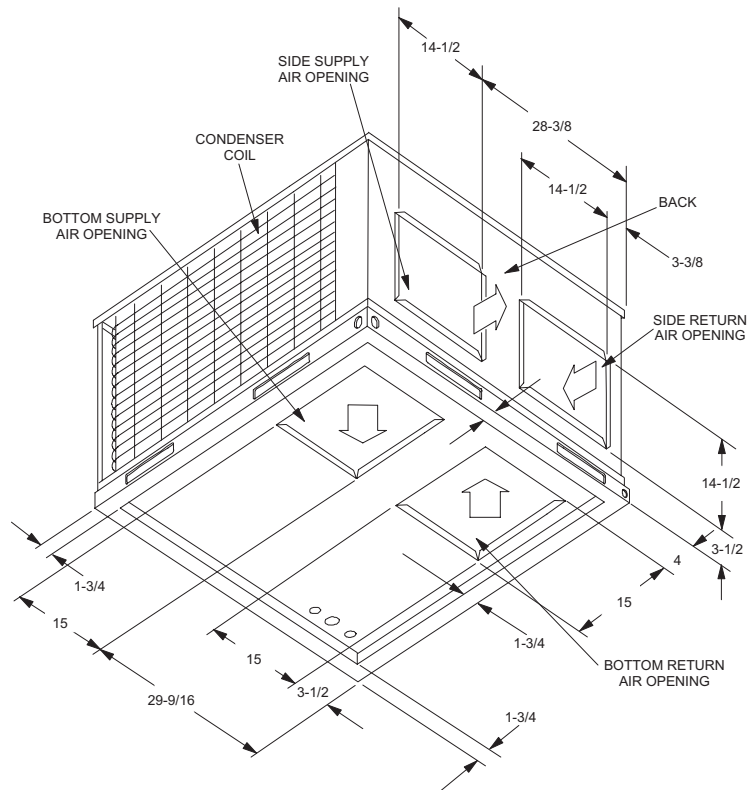

FIGURE 7 - UNIT DIMENSIONS - BACK & BOTTOM

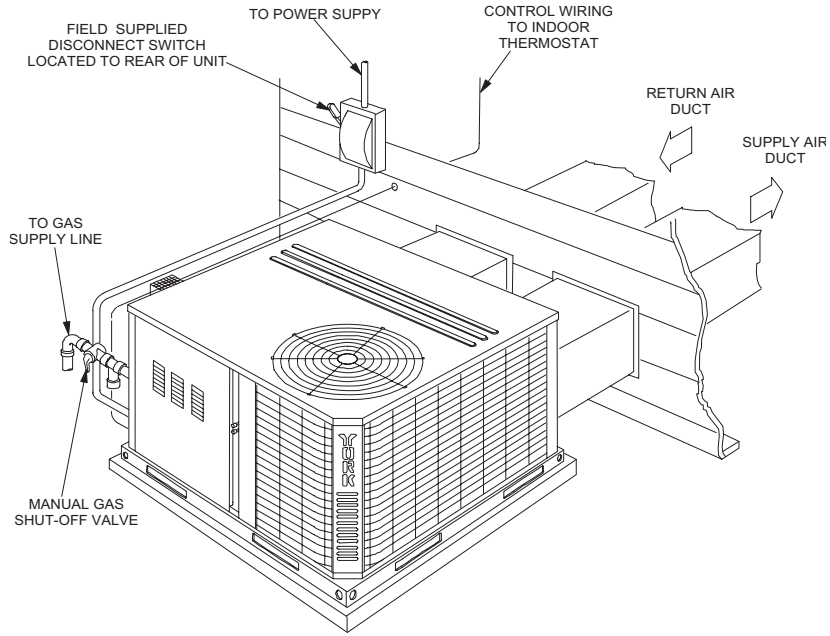

FIGURE 8 - TYPICAL SLAB ON GROUND INSTALLATION

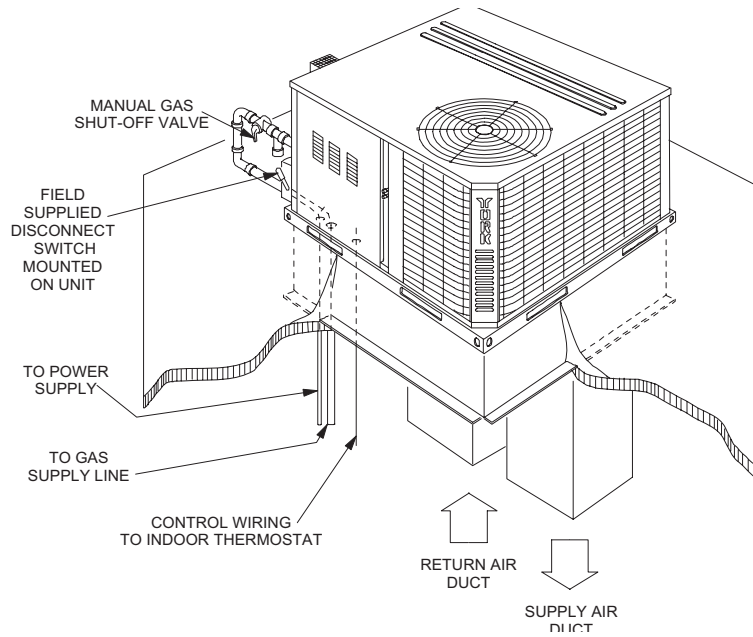

FIGURE 9 - TYPICAL ROOF CURB INSTALLATION

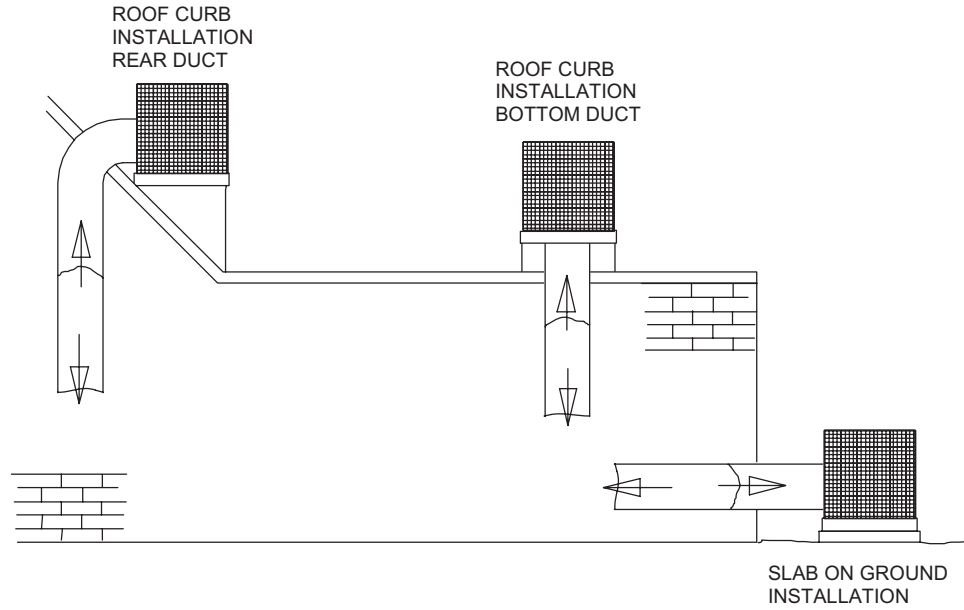

FIGURE 10 - TYPICAL DUCT APPLICATIONS

TABLE 15: UNIT WEIGHTS AND CENTER OF GRAVITY

UNIT SIZE	SHIPPING WEIGHT (lbs.)	OPERATING WEIGHT (lbs.)	CORNER WEIGHTS (location, lbs.)				ECONOMIZER (lbs.)	ROOF CURB (lbs.)
			"A"	"B"	"C"	"D"		
030	395	390	98	95	96	99	40	8" - 70 14" - 75
036	400	395	100	96	98	101		
042	415	410	104	100	101	105		
048	475	470	119	115	116	120		
060	480	475	120	116	117	122		

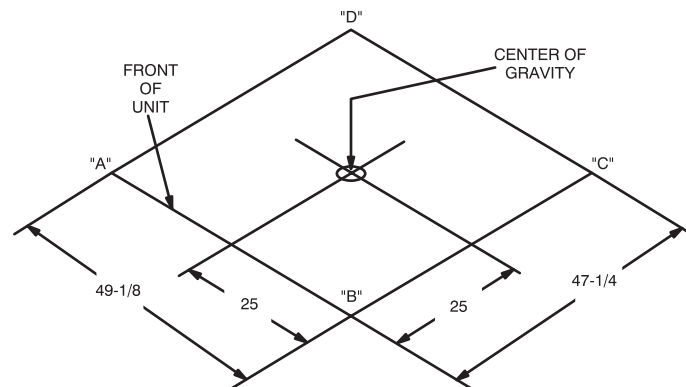

FIGURE 11 - UNIT CENTER OF GRAVITY

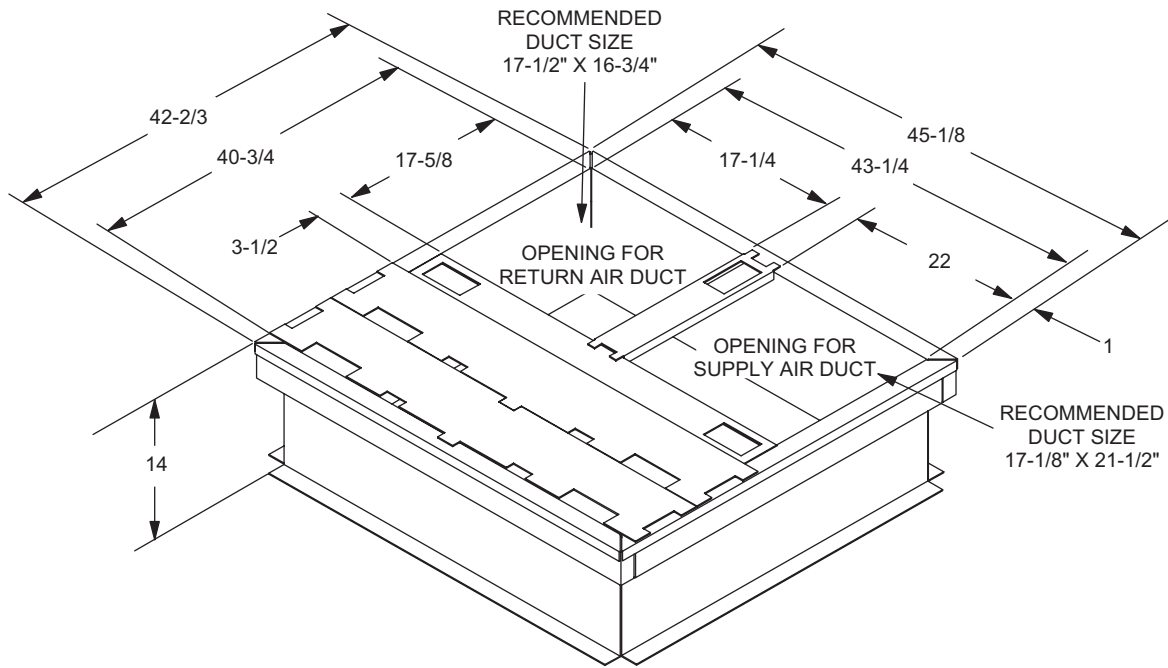

FIGURE 12 - ROOF CURB DIMENSIONS¹

1. 8" Roof curb also available

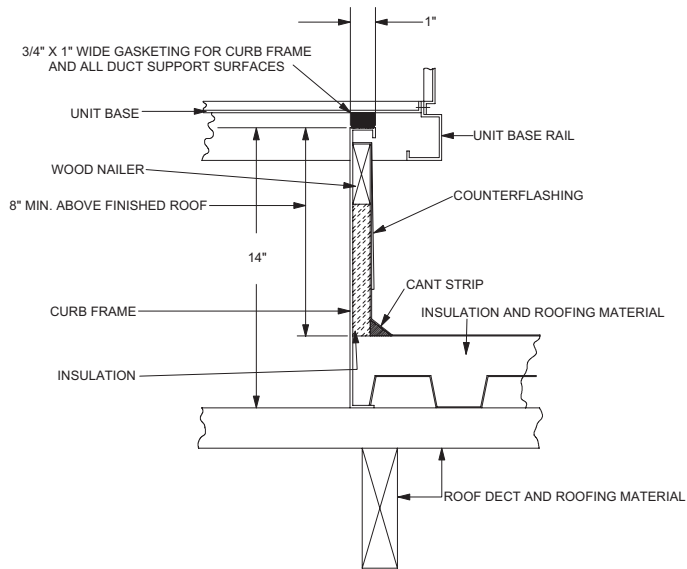

FIGURE 13 - ROOF CURB CROSS SECTION

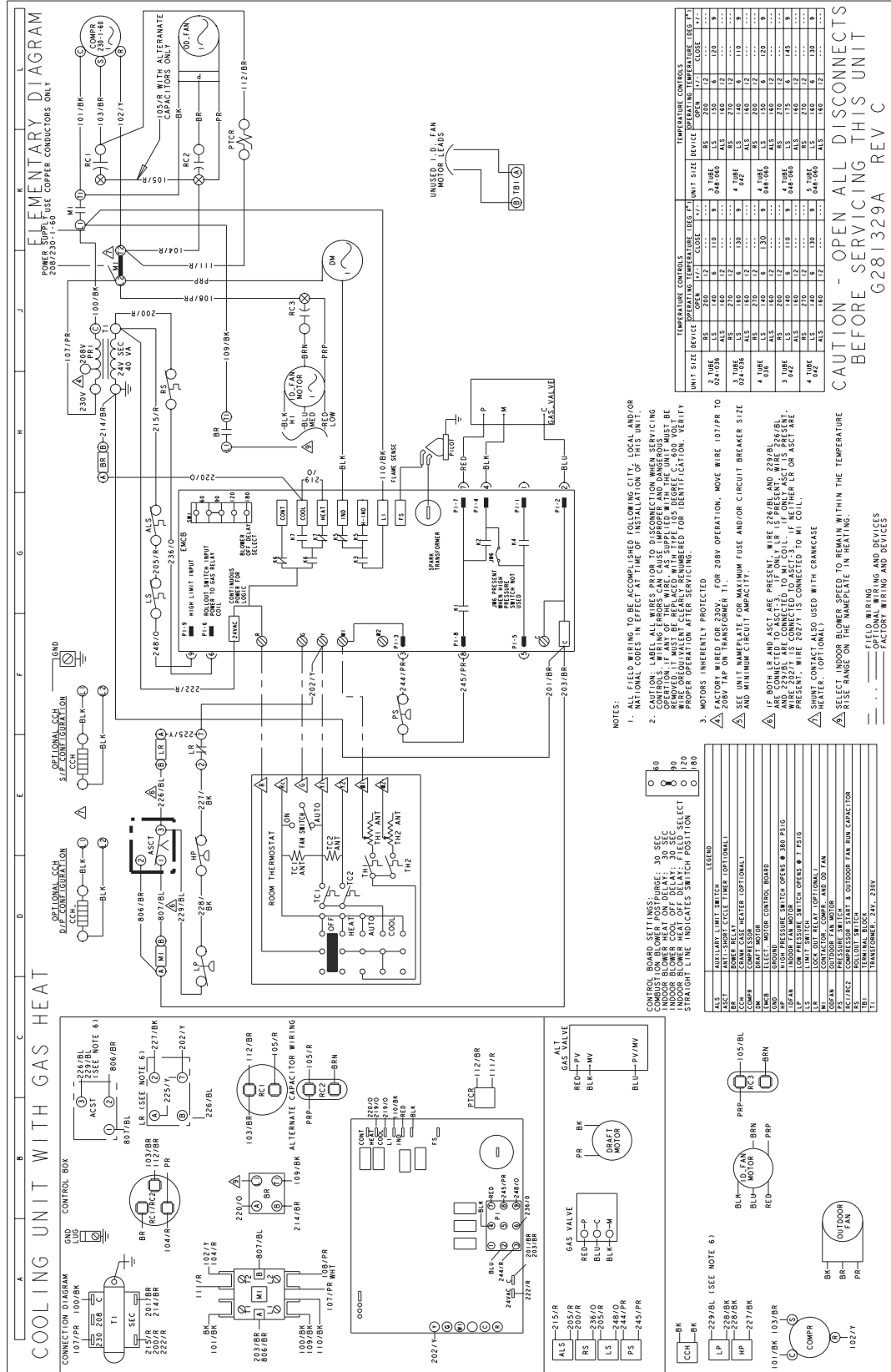

FIGURE 14 - TYPICAL WIRING DIAGRAM DNA 030 THRU 060 (208/230-1-60 POWER SUPPLY)

TYPICAL WIRING DIAGRAM NOTES (SEE FIGURE 14 THRU 16)

1. All field wiring to be accomplished following city, local and/or national codes in effect at time of installation of this unit.
2. Caution: Label all wires prior to disconnection when servicing controls. Wiring errors can cause improper and dangerous operation. If any of the wire as supplied with this unit must be removed it must be replaced with type 105°C, 600V wire or equivalent clearly renumbered for identification. Verify proper operation after servicing.
3. Motors inherently protected.
4. Factory wired for 230V. For 208V operation, move wire 107/PR to 208V. Tap on transformer T1.
5. See unit nameplate for maximum fuse size and/or circuit breaker size and minimum circuit ampacity.
6. If both LR and ASCT are present, wire 801/BL and 805/BL are connected to ASCT-3. If only LR is present wire 801/BL and 805/BL are connected to M1 coil. If only ASCT is present wire 202/Y is connected to ASCT-3. If neither LR or ASCT are present, wire 202/Y is connected to M1 coil as shown.
7. Shunt contact also used with crankcase heater. (optional)
8. Select indoor blower speed to remain within the temperature rise range on the nameplate in heating.



LEGEND	
ALS	AUXILIARY LIMIT SWITCH
ASCT	ANTI-SHORT CYCLE TIMER (OPTIONAL)
BR	BLOWER RELAY
CB	CIRCUIT BREAKER
CCH	CRANK CASE HEATER (OPTIONAL)
COMPR	COMPRESSOR
DM	DRAFT MOTOR
FCB	FAN CONTROL BOARD
GND	GROUND
FS	FREEZE STAT SWITCH (OPTIONAL)
HP	HIGH PRESSURE SWITCH OPENS @ 380 PSIG
IDFAN	INDOOR FAN MOTOR
LP	LOW PRESSURE SWITCH OPENS @ 7 PSIG
LS	LIMIT SWITCH
LR	LOCK OUT RELAY (OPTIONAL)
M1	CONTACTOR, COMPR. AND OD FAN
ODFAN	OUTDOOR FAN MOTOR
PS	PRESSURE SWITCH
RC1 / RC2	COMPRESSOR START & OUTDOOR FAN RUN CAPACITOR
RS	ROLLOUT SWITCH
TB4	TERMINAL BLOCK
T1	TRANSFORMER, 24V, 230V

FIGURE 17 - TYPICAL WIRING DIAGRAM LEGEND

MECHANICAL SPECIFICATIONS

GENERAL

Units shall be manufactured by York International Unitary Products Group in an ISO 9001 certified facility. YORK's Affinity™ package units are designed to handle applications ranging from residential to light commercial and any in between. The Affinity™ is a unit that gives you the flexibility and choices you need in today's market. These packaged cooling/heating air conditioners are designed for outdoor installation. Only utility and duct connections are required at the point of installation. The gas fired heaters have alumi-

nized steel tubular heat exchangers and spark to pilot ignition. They are available in natural gas with field conversion to propane.

DESCRIPTION

Units shall be factory-assembled, single packaged, Electric Cooling/Gas Heating units, designed for outdoor mounted installation. For EER ratings, refer to technical literature. They shall have built in, equal size, field convertible duct connections for down discharge supply/return or horizontal discharge supply/return. The units shall be factory wired, piped, charged with R-22 refrigerant and factory tested prior

to shipment. All unit wiring shall be both numbered and color coded. All units shall be manufactured in a facility certified to ISO 9001 standards, and the cooling performance shall be rated in accordance with DOE and ARI test procedures. The heating performance shall be rated to DOE and GAMA test procedures. Units shall be CSA listed and classified to ANSI Z21.47/CAN/CSA 2.3 standards and UL 1995/CAN/CSA No. 236-M90 conditions.

UNIT CABINET

Unit cabinet shall be constructed of galvanized steel, with exterior surfaces coated with a non-chalking, powdered paint finish, certified at 1000 hours salt spray test per ASTM B117 standards. The unit top shall be a single piece "Water Shed" design, with drip edges and no-seam corners to provide optimum water integrity. Unit shall have a rigidly mounted condenser coil guard to provide protection from objects and personnel after installation. Indoor blower section shall be insulated with up to 3/4" thick, aluminum, foil faced insulation, fastened to prevent insulation from entering the air stream. Cabinet panels shall be "large" size, easily removable for servicing and maintenance, with built-in lift handles. Unit shall be built on a formed, "Super-Structure" design base pan, with embossments at critical points to add strength, rigidity and aid in minimizing sound. Full perimeter base rails shall be provided to assure reliable transit of equipment, overhead rigging, for truck access and proper sealing on roof curb applications. Base rails shall be removable, when required, to lower unit height. Filters shall be furnished and be accessible through a removable access door, sealed airtight. Units vertical discharge and return duct configuration shall be designed to fit between standard 24" O.C. beams without modification to building structure, duct work and base unit. Condensate pan shall be internally sloped and conform to ASHRAE 62-89 self-draining standards, with 3/4" NPTI copper, ridged mount connection.

INDOOR (EVAPORATOR) FAN ASSEMBLY

Fan shall be direct drive, multi-speed design. Job site selected (BHP) brake horsepower shall not exceed the motors nameplate horsepower rating. Fan wheel shall be double-inlet type with forward-curved blades, dynamically balanced to operate smoothly throughout the entire range of operation. Airflow design shall be constant air volume. Bearings shall be sealed and permanently lubricated for longer life and no maintenance. Fan assembly shall be "Slip Track" (slide-out) design for easy removal and cleaning.

OUTDOOR (CONDENSER) FAN ASSEMBLY

The outdoor fan shall be of the direct-driven propeller type, discharge air vertically, have aluminum blades riveted to cor-

rosion resistant steel spider bracket and shall be statically balanced for smooth operation. The outdoor fan motor shall be totally enclosed with permanently lubricated bearings and internally protected against overload conditions.

REFRIGERANT COMPONENTS

Compressors:

- a. Shall be fully hermetic type, direct drive, internally protected with internal high-pressure relief and over temperature protection. The hermetic motor shall be suction gas cooled and have a voltage range of + or - 10% of the unit nameplate voltage.
- b. Shall have internal isolation and sound muffling to minimize vibration and noise, and be externally isolated on a dedicated, independent mounting.

Coils:

- a. Evaporator and condenser coils shall have aluminum plate fins mechanically bonded to seamless internally enhanced copper tubes with all joints brazed.
- b. Evaporator coil shall be of the direct expansion, blow through design, while condenser coil shall be draw through design.

Refrigerant Circuit and Refrigerant Safety Components:

- a. Shall include independent fixed-orifice expansion devices.
- b. Shall include filter/strainer to eliminate any foreign matter.

UNIT OPERATING CHARACTERISTICS

Unit shall be capable of starting and running at 125° F outdoor temperature, exceeding maximum load criteria ARI Standard 210/240. The compressor, with standard controls, shall be capable of operation down to 45° F outdoor temperature. Accessory low ambient kit shall be available for operation to 0° F.

ELECTRICAL REQUIREMENTS

All unit power wiring shall enter unit cabinet at a single factory provided location and be capable of side or bottom entry, to minimize roof penetrations and avoid unit field modifications. Separate side and bottom openings shall be provided for the control wiring.

