



## Heating and Air Conditioning TECHNICAL GUIDE

### R-410A ZF SERIES 15 & 20 TON/53 & 70 KW 50 Hertz

#### Description

YORK® ZF Series Sunline™ units are convertible single package high efficiency rooftops. All models have independent refrigeration circuits for efficient part load operation.

Although the units are primarily designed for curb mounting on a roof, they can also be slab-mounted at ground level or set on steel beams above a finished roof.

All ZF units are self-contained and assembled on rigid full perimeter base rails allowing for overhead rigging. Every unit is completely charged, wired, piped, and tested at the factory to provide a quick and easy field installation.

All models (including those with an economizer) are convertible between bottom and horizontal duct connections.

ZF units are available in the following configurations: cooling only, cooling with electric heat, and cooling with gas heat. Electric heaters are available as factory-installed options only.



## Table of Contents

<b>Description</b> .....	1
<b>Table of Contents</b> .....	2
<b>Component Location</b> .....	3
<b>Nomenclature</b> .....	4
<b>Features and Benefits</b> .....	5
<b>Guide Specifications</b> .....	8
<b>Physical Data</b> .....	11
<b>Capacity Performance</b> .....	13
<b>Airflow Performance</b> .....	21
<b>Sound Performance</b> .....	29
<b>Electrical Data</b> .....	30
<b>Weights and Dimensions</b> .....	32

## Component Location

(ZF shown)

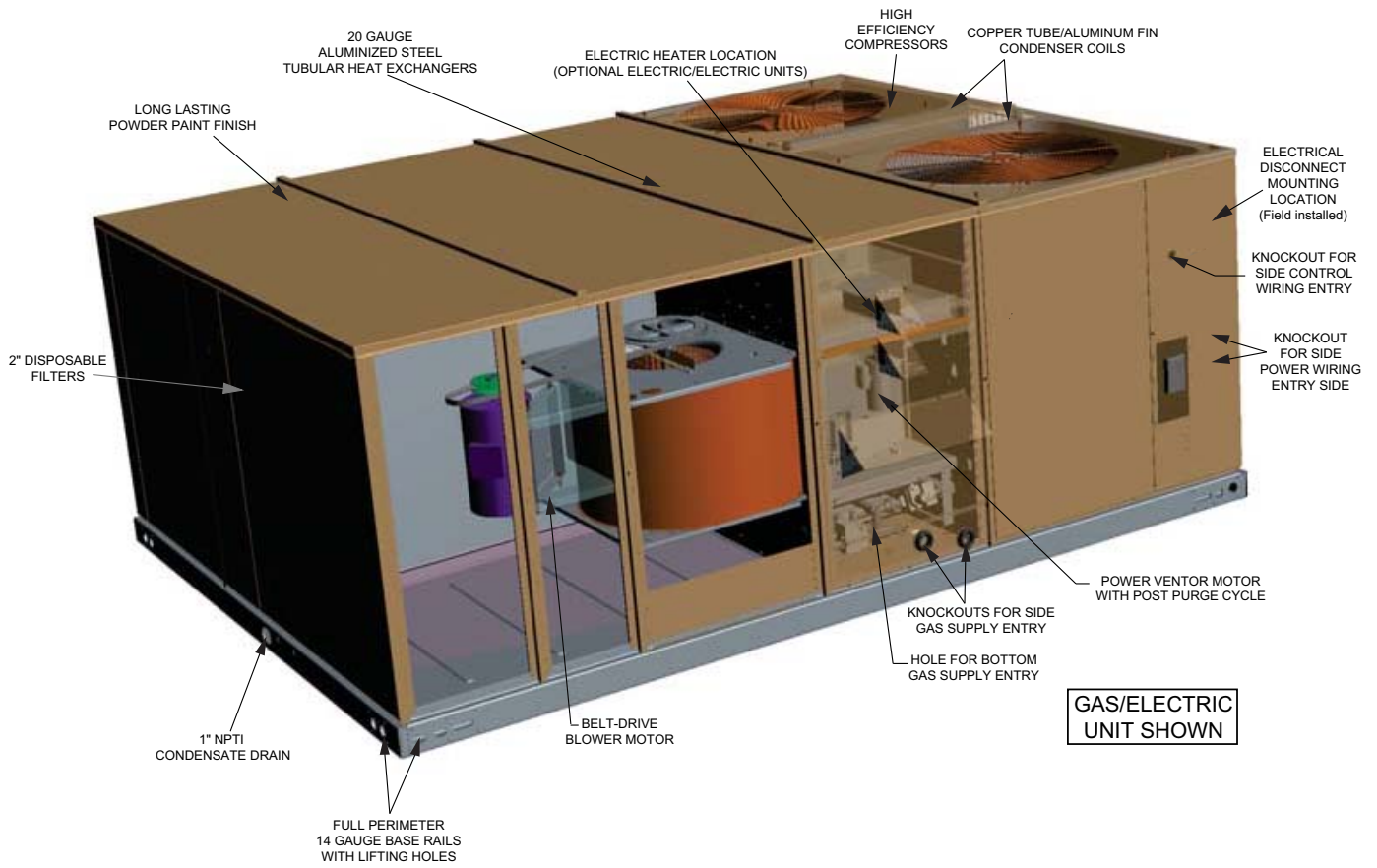

**Nomenclature**

**15 & 20 Ton Sunline Model Number Nomenclature**

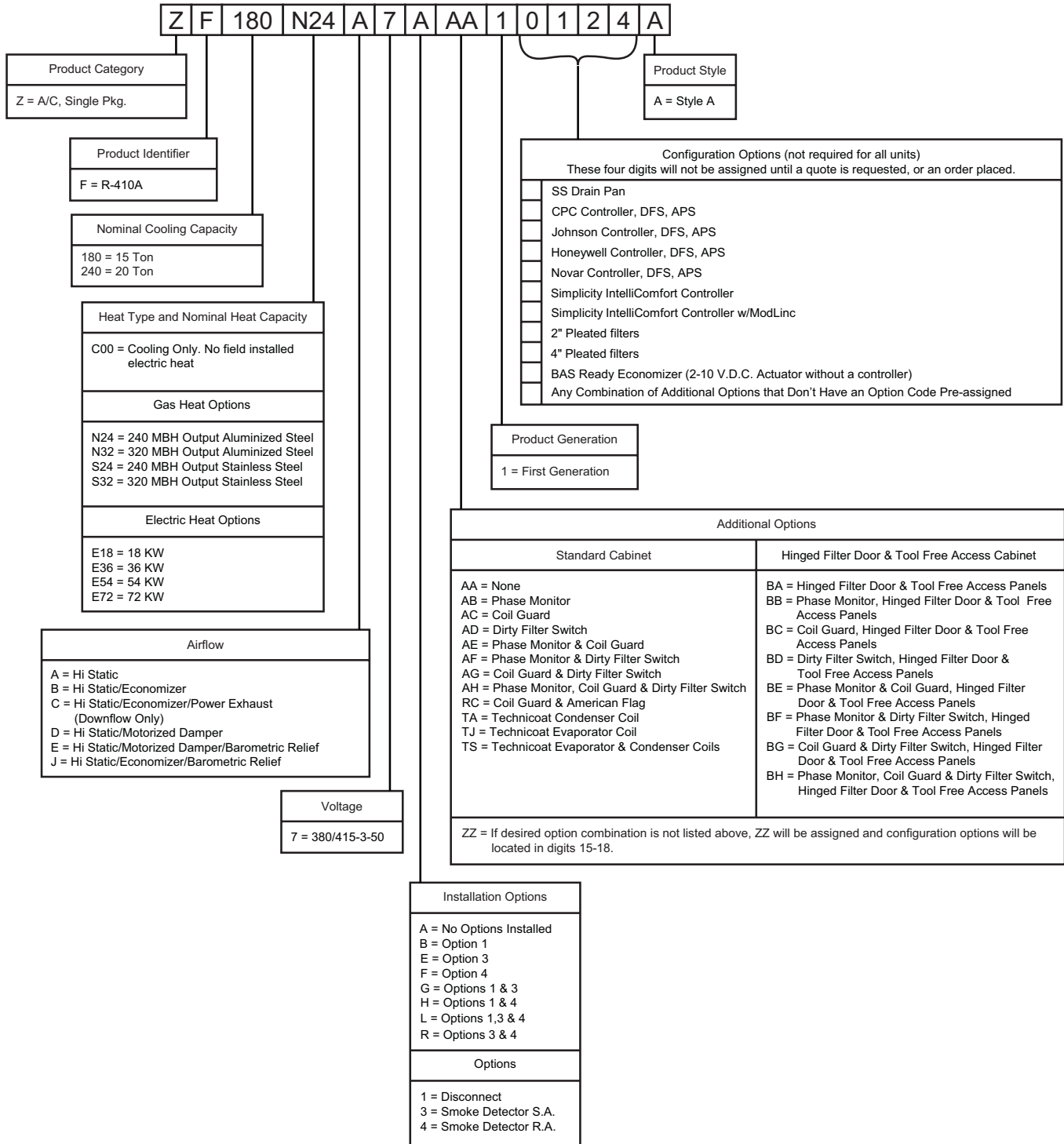

## Features and Benefits

### Standard Features

- **High Efficiency** - High efficiency units reach as high as 10.9 EER. Gas/electric units have electronic spark ignition and power vented combustion with steady state efficiencies of 80%.
- **Balanced Heating** -
  - **Gas Heat** - All gas heat units are built with two heating sections for two equal stages of capacity control. Each section includes a durable heat exchanger with aluminized steel or optional stainless steel tubes, a redundant gas valve, spark ignition, power venting, an ignition module for 100% shut-off and all of the safety controls required to meet the latest ANSI standards. The gas supply piping can be routed into the heating compartment through a hole in the base pan of the unit or through a knockout in the piping panel on the front of the unit.
  - **Electric Heat** - All electric heat models (factory installed only) are wired for a single power source and include a bank of nickel chromium elements mounted at the discharge of the supply air blower to provide a high velocity and uniform distribution of air across the heating elements. Every element is fully protected against excessive current and temperature by fuses and two thermal limit switches. The power supply wiring can be routed into the control box through a threaded pipe connection in the base pan of the unit or through a knockout in the wiring panel on the front of the unit.
- **BAS Controls** - York's Sunline™ series units offer factory mounted BAS controls such as Simplicity® Intelli-Comfort II™, Novar, Honeywell, Johnson, York Commercial Comfort System (YCCS) and CPC.
- **Convertible Airflow Design** - All models (including those with an economizer) are suitable for either bottom or horizontal duct connections. **Models with factory installed power exhaust are suitable for bottom duct connections only.** For bottom duct, you remove the sheet metal panels from the supply and return air openings through the base of the unit. For horizontal duct, you replace the supply and return air panels on the rear of the unit with a side duct flange accessory.
- **Factory Mounted Outdoor Air Dampers** - All models are available with these "factory mounted" outdoor air damper options:
  - Single enthalpy economizer with or without power exhaust
  - BAS-ready economizer with or without power exhaust
  - Motorized outdoor air damper
  - Barometric Relief Damper

A fixed outdoor air intake assembly will be shipped in the return air compartment of all units ordered without an economizer or motorized outdoor air damper option. The assembly includes a rain hood with a damper that can be set for 10, 15 or 25% outdoor air. With bottom duct connections, the fixed outdoor air intake assembly should be mounted

over the opening in the return air panel. With horizontal ductwork, it should be mounted on the return air duct.

- **System Protection** - Suction line freezestats are supplied on all units to protect against loss of charge and coil frosting when the economizer operates at low outdoor air temperatures while the compressors are running. Every unit has solid-core liquid line filter-driers and high and low-pressure switches. Internal compressor protection is standard on all compressors. Phase Monitors are optional on all units. This accessory monitors the incoming power to the unit and protects the unit from phase loss and reversed phase rotation.
- **Advanced Controls** - Simplicity™ ZF control boards have standardized a number of features previously available only as options or by utilizing additional controls.
- **Low Ambient** - An integrated low-ambient control allows all units to operate in the cooling mode down to 0°F outdoor ambient without additional assistance. Optionally, the control board can be programmed to lockout the compressors when the outdoor air temperature is low or when free cooling is available.

### CAUTION

The Simplicity® control board used in this product will effectively operate the cooling system down to 25°F when this product is applied in a comfort cooling application for people. An economizer is typically included in this type of application. When applying this product for process cooling applications (computer rooms, switchgear, etc.), please reference applications bulletin AE-011-07 or call the applications department for Unitary Products @ 1-877-UPG-SERV for guidance.

- **Anti-Short Cycle Protection** - To aid compressor life, an anti-short cycle delay is incorporated into the standard controls. Compressor reliability is further ensured by programmable minimum run times. For testing, the anti-short cycle delay can be temporarily overridden with the push of a button.
- **Lead-Lag** - An integrated Lead-Lag option allows equal run time hours on all compressors, thereby extending the life of all compressors. This option is selectable on the unit control board.
- **Fan Delays** - Fan on and fan off delays are fully programmable. Furthermore, the heating and cooling fan delay times are independent of one another. All units are programmed with default values based upon their configuration of cooling and heat.
- **Safety Monitoring** - The control board monitors the high and low-pressure switches, the freezestats, the gas valve, if applicable, and the temperature limit switch on gas and electric heat units. The unit control board will alarm on ignition failures, compressor lockouts and repeated limit switch trips.
- **Nuisance Trip Protection and Strikes** - To prevent nuisance trouble calls, the control board uses a "three

times, you're out" philosophy. The high and low-pressure switches and the freezestats must trip three times within two hours before the unit control board will lock out the associated compressor.

- **On Board Diagnostics** - Each alarm will energize a trouble light on the thermostat, if so equipped, and flash an alarm code on the control board LED. Each high and low-pressure switch alarm as well as each freezestat alarm has its own flash code. The control board saves the five most recent alarms in memory, and these alarms can be reviewed at any time. Alarms and programmed values are retained through the loss of power.
- **Reliable** - From the beginning - All units undergo computer automated testing before they leave the factory. Units are tested for refrigerant charge and pressure, unit amperage, and 100% functionality. For the long term - All units are painted with a long lasting, powder paint that stands up over the life of the unit. The paint used has been proven by a 1000 hour salt spray test.
- **Full Perimeter Base Rails** - The permanently attached base rails provide a solid foundation for the entire unit and protect the unit during shipment. The rails offer rigging holes so that an overhead crane can be used to place the units on a roof.
- **Easy Installation** - Gas and electric utility knockouts are supplied in the unit underside as well as the side of the unit. Utility connections can be made quickly and with a minimum amount of field labor. All units are shipped with 2" throw-away filters installed.
- **Wide Range of Indoor Airflows** - All supply air blowers are equipped with a belt drive that can be adjusted to meet the exact requirements of the job.
- **Warranty** - All models include a 1-year limited warranty on the complete unit. Compressors and electric heater elements each carry a 5-year warranty. Aluminized steel and stainless steel tubular heat exchangers carry a 10-year warranty.

## Factory Installed Options

YORK® offers several equipment options factory installed, for the ZF Series.

- **Single Input Electronic Enthalpy Economizers** - Includes a slide-in / plug-in damper assembly with fully modulating spring-return motor actuator capable of introducing up to 100% outdoor air with nominal 1% leakage type dampers.  
The enthalpy system contains one sensor that monitors the outdoor air and determines when the air is cool enough and dry enough to provide free cooling.  
The rainhood is painted to match the basic unit and must be field-assembled before installing.
- **BAS-Ready Economizer** - Includes a slide-in / plug-in damper assembly with fully modulating spring-return motor actuator with zero to 95-degree rotation capable of introducing up to 100% outdoor air with nominal 1% leakage type dampers.  
Actuator requires 2-10 VDC input from an external source, such as a field-installed or factory-installed BAS

controller. BAS-ready actuators have an adjustable auxiliary end-switch for optional power exhaust control.

For units with optional VAV or Simplicity® Intelli-Comfort II™ control, a factory-installed, dry bulb sensor determines if outdoor air temperature is low enough to provide free-cooling operation. (Field-installed humidity sensors for either outdoor air or outdoor & return air streams are available for single enthalpy and differential enthalpy configurations, respectively).

The rain hood is painted to match the basic unit and must be field-assembled before installing.

- **Power Exhaust** - Our economizer options are available with power exhaust. Whenever the outdoor air intake dampers are opened for free cooling, the exhaust fan will be energized to prevent the conditioned space from being over-pressurized during economizer operation.  
The exhaust fan, motor and controls are installed and wired at the factory. The rain hood must be assembled and installed in the field.  
The power exhaust option can only be used on bottom duct configurations.
- **Motorized Outdoor Air Intake Damper** - Includes a slide-in / plug-in damper assembly with a 2- position, spring return motor actuator which opens to a pre-set position whenever the supply air blower is operating and will drive fully closed when the blower unit shuts down.  
The rain hood is painted to match the basic unit and must be field assembled before installing.
- **Barometric Relief Damper** - This damper option can be used to relieve internal building air pressure on units with an economizer without power exhaust. This accessory includes a rain hood, a bird screen and a fully assembled damper. With bottom duct connections, the damper should be mounted over the opening in the return air panel. With horizontal ductwork, the accessory should be mounted on the return air duct.
- **Technicoat Condenser Coils** - The condenser coils are coated with a phenolic coating for protection against corrosion due to harsh environments.
- **Technicoat Evaporator Coil** - The evaporator coils are coated with a phenolic coating for protection against corrosion due to harsh environments.
- **Electric Heaters** - wired for single point power supply.  
These nickel chromium heater elements are provided with limit and automatic reset capability to prevent operation at excessive temperatures.
- **Filter Options** - Standard units are shipped with 2" throw-away filters installed. 2" pleated and 4" pleated filters are offered as a factory installed option.
- **Disconnect Switch** - For gas heat units and cooling units with electric heat, a HACR breaker sized to the unit is provided. For cooling only units, a switch sized to the largest electric heat available for the particular unit is provided. Factory installed option only.
- **York Commercial Comfort System (YCCS)** - Provides rooftop system integration for YCCS single zone, change-over bypass and VAV systems.

- **Smoke Detectors** - (supply air & return air) The smoke detectors stop operation of the unit by interrupting power to the control board if smoke is detected within the air compartment.

### **WARNING**

Factory installed smoke detectors in the return air, may be subjected to freezing temperatures during "off" times due to outside air infiltration. These smoke detectors have an operational limit of 32°F to 131°F. Smoke detectors installed in areas that could be outside those limitations will have to be moved to prevent having false alarms.

- **Coil Guard** - Customers can purchase a coil guard kit to protect the condenser coil from damage. This is not a hail guard kit.
- **Stainless Steel Heat Exchanger** - For applications in corrosive environments, this option provides a full stainless steel heat exchanger assembly.
- **Stainless Steel Drain Pan** - An optional rustproof stainless steel drain pan is available to provide years of trouble-free operation in corrosive environments.
- **Phase Monitors** - Designed to prevent unit damage. The phase monitor will shut the unit down in an out-of-phase condition.
- **Dirty Filter Switch** - This kit includes a differential pressure switch that energizes the fault light on the unit thermostat, indicating that there is an abnormally high pressure drop across the filters. Factory installed option or field installed accessory.
- **Hinged Filter Door/"Tool Free" Blower And Access Panels (Not Hinged)** - This option allows for easy access and maintenance.

**NOTE:** Knobs are shipped separately within the unit to prevent shipping damage. These must be field installed for tool free operation.

- **Hinged/"Tool Free" Blower, Blower Motor, Filter And Electric Access Panels** - This option allows for complete hinged and tool free access to the unit's blower, blower motor, filters and electrical panel sections.

### Control Options

- **BAS - Building Automation System Controls (available on two-system cooling product only).**  
**Simplicity™ Intelli-Comfort II™ Control** - The York® Simplicity™ INTELLI-CO<sub>2</sub> sensor to perform Differential Demand Ventilation. It uses a Patented Comfort Ventilation algorithm to provide comfortable ventilation air temperature. The patented economizer-loading algorithm will protect the equipment when harsh operating conditions exist. It uses the INTELLI-Start™ algorithm to maximize energy savings by recovering the building from the Unoccupied Setpoints to the Occupied Setpoints just in time for the Occupied Time Period to begin. The Simplicity™ Intelli-Comfort II™ balances space temperature, ventilation air temperature, CO<sub>2</sub> and humidity for ultimate comfort.

**Simplicity™ Intelli-Comfort II™ with Simplicity™ LINC Control** - The York® Simplicity™ Intelli-Comfort II™ with Simplicity™ LINC control is factory installed. It includes all the features of the Intelli-Comfort II™ control with an additional control to translate communications from MODBUS to the BACnet MSTP protocol.

**Novar® BAS Control** - The Novar® building automation system controller is factory installed. Includes supply air sensor, return air sensor, dirty filter indicator switch, and air proving switch.

**Johnson Controls BAS Control** - The Johnson Control YK-UNT-1126 building automation system controller is factory installed. Includes supply air sensor, return air sensor, dirty filter indicator switch, and air proving switch.

**CPC BAS Control** - The Computer Process Controls Model 810-3060 ARTC Advanced Rooftop building automation system controller is factory installed. Includes supply air sensor, return air sensor, dirty filter indicator switch and air proving switch.

**Honeywell BAS Control** - The Honeywell W7750C building automation system controller is factory installed. Includes air supply sensor, return air sensor, dirty filter indicator switch, and air proving switch.

### Field Installed Accessories

YORK® offers several equipment accessories for field installation, for the ZF Series.

- **Single Input Electronic Enthalpy Economizers** - Includes a slide-in / plug-in damper assembly with fully modulating spring-return motor actuator capable of introducing up to 100% outdoor air with nominal 1% leakage type dampers.  
The enthalpy system contains one sensor that monitors the outdoor air and determines when the air is cool enough and dry enough to provide free cooling.  
The rain hood is painted to match the basic unit and must be field-assembled before installing.
- **Motorized Outdoor Air Intake Damper** - Includes a slide-in / plug-in damper assembly with a 2-position, spring return motor actuator which opens to some pre-set position whenever the supply air blower is operating and will drive fully closed when the blower unit shuts down.  
The rain hood is painted to match the basic unit and must be field assembled before installing.
- **Roof Curbs** - Fourteen-inch high roof curbs provide a water-tight seal between the unit and the finished roof. These full perimeter curbs meet the requirements of the National Roofing Contractors Association (NRCA) and are shipped knocked-down for field assembly.  
They're designed to fit inside the base rails of the unit and include both a wood nailing strip and duct hanger supports.
- **High Altitude Natural Gas** - Burner orifices and pilot orifices are provided for proper furnace operation at altitudes up to 6,000 feet.
- **Propane** - Burner orifices, pilot orifices and gas valve parts are provided to convert a natural gas furnace to propane.
- **High Altitude Propane** - Burner orifices and pilot orifices are provided for proper furnace operation at altitudes up

to 6,000 feet. This accessory supplements the basic propane conversion kit.

- **Side Duct Flanges** - One-inch flanges replace the supply and return air panels on the rear of the unit to accommodate horizontal duct connections. These flanges can also be used individually for bottom supply / horizontal return or horizontal supply/bottom return. They cannot be used on units with power exhaust.
- **Barometric Relief Damper** - This damper accessory can be used to relieve internal building air pressure on units with an economizer without power exhaust. This accessory includes a rain hood, a bird screen and a fully assembled damper. With bottom duct connections, the damper should be mounted over the opening in the return air panel. With horizontal ductwork, the accessory should be mounted on the return air duct.
- **Enthalpy Accessory Control Kit** - This kit contains the required components to convert a single enthalpy economizer to dual enthalpy.
- **Burglar Bars** - Mount in the supply and return openings to prevent entry into the duct work.
- **Flue Exhaust Extension Kit** - In locations with wind or weather conditions which may interfere with proper exhausting of furnace combustion products, this kit can be installed to prevent the flue exhaust from entering nearby fresh air intakes.
- **Wood Skid** - Allows unit to be handled with 90" forks.
- **CO<sub>2</sub> Sensor** - Senses CO<sub>2</sub> levels and automatically overrides the economizer when levels rise above the present limits.
- **Coil Guard** - Customers can purchase a coil guard kit to protect the condenser coil from damage. This is not a hail guard kit.
- **Phase Monitors** - Designed to prevent unit damage. The phase monitor will shut the unit down in an out-of phase condition.

## Guide Specifications

### General

Units shall be manufactured by Johnson Controls Unitary Products in an ISO 9001 certified facility.

ZF models have 2 condenser fan motors and compressors. All compressors include crankcase heat and internal discharge temperature protection. Every refrigerant circuit includes an expansion valve, a liquid line filter-drier, a discharge line high pressure switch and a suction line with a freezestat and low pressure/loss of charge switch. The unit control circuit includes 75 VA and 150 VA transformers, a 24-volt circuit breaker and a relay board with two compressor lockout circuits, a terminal strip for thermostat wiring, plus an additional set of pin connectors to simplify the interface of additional field controls. All units have long lasting powder paint cabinets with 1000 hour salt spray test approval under ASTM-B117 procedures. All models include a 1-year limited warranty on the complete unit.

Compressors and electric heater elements carry an additional 4-year warranty. Aluminized steel tubular heat exchangers carry an additional 9-year warranty.

### Description

ZF units shall be factory-assembled, single packaged, ZF\*\*\*N Electric Cooling/Gas Heat, ZF\*\*\*C/E Electric Cooling/Optional Electric Heat, designed for outdoor mounted installation.

They shall have built-in field convertible duct connections for down discharge supply/return or horizontal discharge supply/return, and be available with factory installed options or field installed accessories. The units shall be factory wired, piped, charged with R-410A refrigerant and factory tested prior to shipment. All unit wiring shall be both numbered and color coded. All units shall be manufactured in a facility certified to ISO 9001 standards and the cooling performance shall be rated in accordance with DOE and AHRI test procedures. Units shall be classified to ANSI Z21.47 standards, UL 1995/CAN/CSA No. 236-M90 conditions.

### Unit Cabinet

Unit cabinet shall be constructed of galvanized steel, with exterior surfaces coated with a non-chalking, powdered paint finish, certified at 1000 hours salt spray test per ASTM-B117 standards. Indoor blower section shall be insulated with a minimum 1/2" thick insulation, coated on the airside. Aluminum foil faced insulation shall be used in the furnace compartment and be fastened with rigid fasteners to prevent insulation from entering the air stream. Cabinet panels shall be easily removable for servicing and maintenance. Full perimeter base rails shall be provided to assure reliable transit of equipment, overhead rigging and proper sealing on roof curb applications. Disposable 2" filters shall be furnished and be accessible through a removable access door, sealed airtight. Units filter track shall be designed to accommodate either 2" or 4" filters. Fan performance measuring ports shall be provided on the outside of the cabinet to allow accurate air measurements of evaporator fan performance without removing panels or creating air by-pass of the coils. Condensate pan shall be internally sloped and conform to ASHRAE 62-89 self-draining standards. Condensate connection shall be a minimum of 1" I.D. female and be a ridged mount connection. Unit shall incorporate a fixed outdoor air damper with an outdoor air intake opening covered with a bird screen and a rain hood painted to match the exterior of the unit.

### Indoor (Evaporator) Fan Assembly

Fan shall be a belt drive assembly and include an adjustable-pitch motor pulley. Job site selected (B.H.P.) brake horsepower shall not exceed the motors nameplate horsepower rating, plus the service factor. Units shall be designed not to operate above service factor. Fan wheel shall be double-inlet type with forward-curved blades, dynamically balanced to operate smoothly throughout the entire range of operation. Airflow design shall be constant air volume.

## Outdoor (Condenser) Fan Assembly

The outdoor fans shall be of the direct-driven propeller type, discharge air vertically, have aluminum blades riveted to corrosion resistant steel spider brackets and shall be dynamically balanced for smooth operation. The 2 outdoor fan motors shall be totally enclosed with permanently lubricated bearings, internally protected against overload conditions and staged independently.

## Refrigerant Components

Compressors:

- a. Shall be Scroll compressors internally protected with internal discharge temperature protection over temperature protection.
- b. Shall have internal spring isolation and sound muffling to minimize vibration and noise, and be externally isolated on a dedicated, independent mounting.

Coils:

- a. Evaporator and condenser coils shall have aluminum plate fins mechanically bonded to seamless internally enhanced copper tubes with all joints brazed. Special Phenolic coating shall be available as a factory option.
- b. Evaporator and Condenser coils shall be of the direct expansion, draw-thru, design.

Refrigerant Circuit and Refrigerant Safety Components shall include:

- a. Balance-port thermostatic expansion valve with independent circuit feed system.
- b. Filter drier/strainer to eliminate any moisture or foreign matter.
- c. Accessible service gage connections on both suction and discharge lines to charge, evacuate, and measure refrigerant pressure during any necessary servicing or troubleshooting, without losing charge.
- d. The refrigeration system shall provide at least 10° F of sub-cooling at design conditions.
- e. All models shall have two independent circuits.

## Unit Controls

- a. Unit shall be complete with self-contained low-voltage control circuit protected by a resettable circuit breaker on the 24-volt transformer side.
- b. Unit shall incorporate a lockout circuit which provides reset capability at the space thermostat or base unit, should any of the following standard safety devices trip and shut off compressor.
  1. High-pressure switch.
  2. Freeze-protection thermostat, evaporator coil. If any of the above safety devices trip, a LED (light-emitting diode) indicator shall flash a diagnostic code that indicates which safety switch has tripped.
- c. Loss-of-charge/Low-pressure switch.

- d. Unit shall incorporate "AUTO RESET" compressor over temperature, over current protection.
- e. Unit shall operate with conventional thermostat designs and have a low voltage terminal strip for easy hook-up.
- f. Unit control board shall have on-board diagnostics and fault code display.
- g. Standard controls shall include anti-short cycle and low voltage protection, and permit cooling operation down to 25°F.
- h. Control board shall monitor each refrigerant safety switch independently.
- i. Control board shall retain last 5 fault codes in non volatile memory, which will not be lost in the event of a power loss.

## Gas Heating Section (ZF\*\*\*N Models)

Shall be designed with induced draft combustion with post purge logic and energy saving direct spark ignition, redundant main gas valve. Ventor wheel shall be constructed of stainless steel for corrosion resistance. The heat exchanger shall be of the tubular type, constructed of T1-40 aluminized steel for corrosion resistance and allowing minimum mixed air entering temperature of 25 °F. Burners shall be of the in-shot type, constructed of aluminum coated steel and contain air mixture adjustments. All gas piping shall enter the unit cabinet at a single location through either the side or curb, without any field modifications. An integrated control board shall provide timed control of evaporator fan functioning and burner ignition. Heating section shall be provided with the following minimum protection:

- a. Primary and auxiliary high-temperature limit switches.
- b. Induced draft motor speed sensor.
- c. Flame roll out switch (automatic reset).
- d. Flame proving controls. Unit shall have two independent stages of capacity.

## Electric Heating (ZF\*\*\*C/E Models)

Nickel chromium electric heating elements shall be provided as required by the application with 1 or 2 stage control, as required, from 18 KW to 72 KW nominal capacities. The heating section shall have a primary limit control(s) and automatic reset to prevent the heating element system from operating at an excessive temperature. Units with Electric Heating shall be wired for a single point power supply with branch circuit fusing (where required).

## Unit Operating Characteristics

Unit shall be capable of starting and running at 125° F outdoor temperature, exceeding maximum load criteria of AHRI Standard 340/360. The compressor, with standard controls, shall be capable of operation down to 25° F outdoor temperature. Unit shall be provided with fan time delay to prevent cold air delivery before heat exchanger warms up (Gas heat only).

## Electrical Requirements

All unit power wiring shall enter unit cabinet at a single factory provided location and be capable of side or bottom entry, to minimize roof penetrations and avoid unit field modifications. Separate side and bottom openings shall be provided for the control wiring.

## Standard Limited Warranties

- Compressor 5 Years
- Heat Exchanger 10 Years
- Electric Heat Element 5 Years
- Other Parts 1 Year

## Optional Outdoor Air (Shall be made available by either/or):

- **Electronic Enthalpy Automatic Economizer** - Outdoor and return air dampers that are interlocked and positioned by a fully-modulating, spring-return damper actuator. The maximum leakage rate for the outdoor air intake dampers shall not exceed 2% when dampers are fully closed and operating against a pressure differential of 0.5 IWG. A unit-mounted potentiometer shall be provided to adjust the outdoor and return air damper assembly to take in CFM of outdoor air to meet the minimum ventilation requirement of the conditioned space during normal operation. During economizer operation, a mixed-air temperature control shall modulate the outdoor and return air damper assembly to prevent the supply air temperature from dropping below 55°F. Changeover from compressor to economizer operation shall be provided by an integral electronic enthalpy control that feeds input into the basic module. The outdoor intake opening shall be covered with a rain hood that matches the exterior of the unit. Water eliminator/filters shall be provided. Simultaneous economizer/compressor operation is also possible. Dampers shall fully close on power loss.
- **Motorized Outdoor Air Dampers** - Outdoor and return air dampers that are interlocked and positioned by a 2-position, spring-return damper actuator. The maximum leakage rate for the outdoor air intake dampers shall not exceed 2% when dampers are fully closed and operating against a pressure differential of 0.5 IWG. A unit-mounted potentiometer shall be provided to adjust the outdoor and return air damper assembly to take in the design CFM of outdoor air to meet the ventilation requirements of the conditioned space during normal operation. Whenever the indoor fan motor is energized, the dampers open up to one of two pre-selected positions - regardless of the outdoor air enthalpy. Dampers return to the fully closed position when the indoor fan motor is de-energized. Dampers shall fully close on power loss.

## Other Pre-engineered Accessories Available

- **Roof Curb** - 14" high, full perimeter curb with wood nailer (shipped knocked-down).

- **100% Barometric Relief Damper** - Contains a rain hood, air inlet screen, exhaust damper and mounting hardware. Used to relieve internal air pressure through the unit.
- **Propane Conversion Kit** - Contains new orifices and gas valve parts to convert from natural to L.P. gas. One per unit required.
- **High Altitude - Natural Gas** - Contains orifices required for applications between 2000 and 6000 feet altitude.
- **High Altitude - Propane Gas** - Contains orifices required for applications between 2000 and 6000 feet altitude. Must be used with propane conversion kit.
- **Burglar Bars** - Designed to work with above roof curbs, depending on unit model. Fits duct openings of curb supply and return air openings.
- **Side Duct Flange** - Supply and return air duct flanges for side duct applications. Do not use on units with power exhaust.
- **Wood Skid** - Allows unit to be handled with 90" forks.
- **Economizer/motorized Damper Rain Hood (ZFN/E/C240 only)** - Contains all hood panels and the hardware for assembling.
- **Anti-Recycle Timer** - Assures 5-minute off time between compressor cycles.
- **Coil Guard Kit** - Guard for cooling coil.

## OTHER FACTORY INSTALLED OPTIONS

- **Power Exhaust Option** - To work in conjunction with economizers.
- **Stainless Steel Heat Exchanger**
- **Stainless Steel Drain Pan**
- **Technicoat Phenolic Coated Condenser And Evaporator Coil**
- **Electronic Single Enthalpy Economizer**
- **Dirty Filter Switch**
- **Phase Monitor**
- **Coil Guard**
- **Bas Controls** - Simplicity® Intelli-Comfort II™, CPC, JOHNSON, HONEYWELL, NOVAR, YORK COMMERCIAL COMFORT SYSTEM (YCCS)
- **BAS Ready Economizer** (2-10 V.D.C. Actuator Without a Controller)
- **Hinged Filter Door Access And Tool Free Access Panels**
- **Hinged Tool Free Blower, Blower Motor, Filter And Electrical Access Panels**
- **2" Pleated Filters, MERV 7**
- **4" Pleated Filters, MERV 13**
- **Disconnect Switch**
- **Supply Air Smoke Detector**
- **Return Air Smoke Detector**

## Physical Data

### ZF180-240 Physical Data

Component	Models			
	ZF180		ZF240	
Nominal Tonnage	15		20	
<b>AHRI COOLING PERFORMANCE</b>				
Gross Capacity @ AHRI A point (K Btu)	204		259	
AHRI net capacity (K Btu)	195		246	
EER	10.9		10.4	
SEER	-		-	
IEER	11.26		10.88	
Nominal CFM	6000		8000	
System power (KW)	17.9		23.7	
Refrigerant type	R-410A		R-410A	
Refrigerant charge (lb-oz)				
System 1	22-8		20-4	
System 2	21-8		21-4	
<b>AHRI HEATING PERFORMANCE</b>				
Heating model	24	32	24	32
Heat input (K Btu)	300	400	300	400
Heat output (K Btu)	240	320	240	320
AFUE%	-	-	-	-
Steady state efficiency (%)	80	80	80	80
No. burners	6	8	6	8
No. stages	2	2	2	2
Temperature Rise Range (°F)	20-50	35-65	20-50	35-65
Gas Limit Setting (°F)	195	195	195	195
Gas piping connection (in.)	1	1	1	1
<b>DIMENSIONS (inches)</b>				
Length	125-1/4		136-1/4	
Width	92		92	
Height	48-5/8		52-5/8	
OPERATING WT. (lbs.)	1680		2400	
<b>COMPRESSORS</b>				
Type	Scroll		Scroll	
Quantity	2		2	
Unit Capacity Steps (%)	50 / 100		50 / 100	
<b>CONDENSER COIL DATA</b>				
Face area (Sq. Ft.)	36.0		43.3	
Rows	3		3	
Fins per inch	13.5		15	
Tube diameter (in.)	3/8		3/8	
Circuitry Type	Standard		Standard	
<b>EVAPORATOR COIL DATA</b>				
Face area (Sq. Ft.)	15.5		20.1	
Rows	4		4	
Fins per inch	14		14	
Tube diameter	3/8		3/8	
Circuitry Type	Intertwined		Intertwined	
Refrigerant control	TXV		TXV	

**ZF180-240 Physical Data (Continued)**

Component	Models	
	ZF180	ZF240
Nominal Tonnage	15	20
<b>CONDENSER FAN DATA</b>		
Quantity	2	2
Fan diameter (Inch)	30	30
Type	Prop	Prop
Drive type	Direct	Direct
No. speeds	1	1
Number of motors	2	2
Motor HP each	1.25	1.25
RPM	950	950
Nominal total CFM	6000	8000
<b>BELT DRIVE EVAP FAN DATA</b>		
Quantity	1	1
Fan Size (Inch)	15 X 15	18 X 15
Type	Centrifugal	Centrifugal
Motor Sheave	1VP62	1VP75
Blower Sheave	BK75	BK100
Belt	BX68	BX75
Motor HP each	4.0	6.3
RPM	1450	1450
Frame size	184T	213T
<b>FILTERS</b>		
Quantity - Size	5 - (18 x 24 x 2) <sup>1,2</sup>	12 - (12 x 24 x 2) <sup>1,2</sup>
	-	-
	5 - (18 x 24 x 4) <sup>3</sup>	2 - (20 x 24 x 4),
	-	4 - (24 x 24 x 4) <sup>3</sup>

1. 2 In. Throwaway, Standard, MERV (Minimum Efficiency Reporting Value) 3.
2. 2 In. Pleated, Optional, MERV 7.
3. 4 In. Pleated, Optional, MERV 13.

**ZF180-240 Unit Limitations**

Size (Tons)	Unit Voltage	Unit Limitations		
		Applied Voltage		Outdoor DB Temp
		Min	Max	Max (°F) / (°C)
180 (15)	380/415-3-50	342	457	125.6 / 52
240 (20)	380/415-3-50	342	457	125.6 / 52

# Capacity Performance

## ZF180-240 Cooling Capacities

### ZF180 (15 Ton) Imperial

Air on Evaporator Coil		Temperature of Air on Condenser Coil															
CFM	WB (°F)	Total Capacity <sup>1,2</sup> (MBh)	Total Input (kW) <sup>3</sup>	Sensible Capacity (MBh)						Total Capacity <sup>1,2</sup> (MBh)	Total Input (kW) <sup>3</sup>	Sensible Capacity (MBh)					
				Return Dry Bulb (°F)								Return Dry Bulb (°F)					
				90	85	80	75	70	65			90	85	80	75	70	65
		85°F								95°F							
3750	77	236.4	15.8	101.2	86.6	72.0	-	-	-	204.0	17.5	91.0	76.7	62.5	-	-	-
	72	205.4	15.7	121.0	106.4	91.8	77.1	-	-	182.0	17.2	112.3	98.1	83.9	69.6	-	-
	67	174.3	15.5	140.8	126.2	111.6	96.9	82.3	-	159.9	16.9	133.7	119.5	105.2	91.0	76.8	-
	62	162.6	15.3	162.6	156.0	137.2	122.6	107.9	93.3	146.5	16.8	146.5	146.5	130.7	116.5	102.3	88.0
4500	77	253.8	16.2	114.6	97.4	80.3	-	-	-	222.1	17.8	103.4	86.8	70.1	-	-	-
	72	220.5	16.1	136.6	119.5	102.4	85.3	-	-	198.1	17.5	127.4	110.7	94.1	77.4	-	-
	67	187.2	15.9	158.7	141.6	124.5	107.4	90.2	-	174.1	17.3	151.4	134.7	118.0	101.4	84.7	-
	62	174.6	15.7	174.6	170.2	153.1	136.0	118.8	101.7	159.5	17.1	159.5	159.5	145.7	129.0	112.3	95.7
	57	172.9	15.7	172.9	172.9	156.4	139.3	122.1	105.0	156.9	16.7	156.9	156.9	145.3	128.7	112.0	95.3
5250	77	271.3	16.6	127.9	108.3	88.7	-	-	-	240.2	18.1	115.9	96.8	77.7	-	-	-
	72	235.7	16.5	152.3	132.6	113.0	93.4	-	-	214.2	17.9	142.5	123.4	104.3	85.2	-	-
	67	200.1	16.3	176.6	157.0	137.4	117.8	98.2	-	188.3	17.6	169.1	150.0	130.9	111.8	92.6	-
	62	186.6	16.1	186.6	184.4	169.0	149.4	129.7	110.1	172.5	17.4	172.5	172.5	160.6	141.5	122.4	103.3
	57	184.8	16.1	184.8	184.8	172.6	153.0	133.4	113.8	169.7	17.0	169.7	169.7	160.3	141.1	122.0	102.9
6000	77	288.7	17.0	141.2	119.1	97.0	-	-	-	258.3	18.5	128.4	106.9	85.3	-	-	-
	72	250.8	16.9	167.9	145.8	123.7	101.5	-	-	230.4	18.2	157.6	136.1	114.5	93.0	-	-
	67	212.9	16.7	194.5	172.4	150.3	128.2	106.1	-	202.5	17.9	186.8	165.2	143.7	122.1	100.6	-
	62	198.6	16.5	198.6	198.6	184.9	162.8	140.6	118.5	185.5	17.7	185.5	185.5	175.6	154.1	132.5	111.0
	57	196.7	16.5	196.7	196.7	188.8	166.7	144.6	122.5	182.5	17.3	182.5	182.5	175.2	153.6	132.1	110.5
6750	72	254.9	17.9	175.3	151.0	126.8	102.5	-	-	234.1	19.5	167.1	143.4	119.7	96.0	-	-
	67	216.3	17.8	202.6	178.4	154.1	129.9	105.6	-	205.8	19.2	197.9	173.9	156.8	126.5	102.9	-
	62	201.8	17.5	201.8	201.8	189.5	165.3	141.0	116.8	188.6	19.0	188.6	188.6	183.6	159.9	136.2	112.5
	57	199.9	17.5	199.9	199.9	193.6	169.4	145.1	120.8	185.5	18.6	185.5	185.5	181.8	158.1	134.5	110.8
		105°F								115°F							
3750	77	182.9	19.0	84.6	69.9	55.3	-	-	-	161.8	20.6	78.2	63.1	48.1	-	-	-
	72	167.5	18.7	107.7	93.1	78.4	63.8	-	-	153.1	20.3	103.1	88.0	73.0	57.9	-	-
	67	152.2	18.4	130.8	116.2	101.6	86.9	72.3	-	144.5	19.9	128.0	112.9	97.9	82.8	67.8	-
	62	140.0	18.3	140.0	140.0	124.9	110.2	95.6	81.0	133.5	19.9	133.5	133.5	119.0	104.0	88.9	73.9
4500	77	197.5	19.4	95.1	78.3	61.5	-	-	-	173.0	20.9	86.8	69.9	53.0	-	-	-
	72	180.9	19.1	121.2	104.4	87.6	70.8	-	-	163.7	20.6	114.9	98.0	81.0	64.1	-	-
	67	164.3	18.8	147.2	130.4	113.6	96.8	80.0	-	154.5	20.3	142.9	126.0	109.1	92.2	75.2	-
	62	151.1	18.6	151.1	151.1	138.9	122.1	105.3	88.5	142.7	20.2	142.7	142.7	132.1	115.2	98.3	81.3
	57	149.4	18.4	149.4	149.4	137.0	120.2	103.4	86.6	141.9	20.1	141.9	141.9	128.6	111.7	94.8	77.9
5250	77	212.2	19.7	105.7	86.8	67.8	-	-	-	184.2	21.2	95.5	76.7	57.9	-	-	-
	72	194.3	19.4	134.6	115.7	96.7	77.7	-	-	174.3	20.9	126.7	107.9	89.1	70.3	-	-
	67	176.4	19.1	163.5	144.5	125.6	106.6	87.6	-	164.5	20.6	157.9	139.1	120.3	101.5	82.6	-
	62	162.2	18.9	162.2	162.2	153.0	134.0	115.0	96.1	151.9	20.5	151.9	151.9	145.3	126.4	107.6	88.8
	57	160.4	18.7	160.4	160.4	150.8	131.9	112.9	93.9	151.1	20.4	151.1	151.1	141.4	122.6	103.8	85.0
6000	77	226.8	20.0	116.3	95.2	74.1	-	-	-	195.4	21.5	104.2	83.5	62.8	-	-	-
	72	207.7	19.7	148.1	127.0	105.8	84.7	-	-	184.9	21.2	138.6	117.9	97.1	76.4	-	-
	67	188.5	19.4	179.9	158.7	137.6	116.5	95.3	-	174.5	20.9	172.9	152.2	131.5	110.8	90.1	-
	62	173.4	19.2	173.4	173.4	167.0	145.9	124.7	103.6	161.2	20.8	161.2	161.2	158.4	137.7	117.0	96.2
	57	171.4	19.0	171.4	171.4	164.7	143.6	122.4	101.3	160.3	20.7	160.3	160.3	154.2	133.5	112.8	92.1
6750	72	210.4	20.7	155.1	131.4	107.7	84.1	-	-	186.7	21.9	143.0	119.4	95.8	72.1	-	-
	67	190.9	20.4	187.0	165.0	144.6	117.7	94.1	-	176.0	21.7	176.0	156.1	132.5	108.9	85.2	-
	62	175.9	20.0	175.9	175.9	169.9	146.2	122.6	98.9	163.3	21.1	163.3	163.3	156.2	132.5	108.9	85.3
	57	173.9	19.8	173.9	173.9	166.9	143.3	119.6	96.0	162.4	20.9	162.4	162.4	152.0	128.4	104.8	81.1

**ZF180 (15 Ton) Imperial (Continued)**

Air on Evaporator Coil		Temperature of Air on Condenser Coil															
CFM	WB (°F)	Total Capacity <sup>1,2</sup> (MBh)	Total Input (kW) <sup>3</sup>	Sensible Capacity (MBh)						Total Capacity <sup>1,2</sup> (MBh)	Total Input (kW) <sup>3</sup>	Sensible Capacity (MBh)					
				Return Dry Bulb (°F)								Return Dry Bulb (°F)					
				90	85	80	75	70	65			90	85	80	75	70	65
				118.4°F						125°F							
3750	77	159.3	21.1	75.0	60.8	45.6	-	-	-	140.7	22.1	69.0	56.3	40.9	-	-	-
	72	152.7	20.8	101.5	86.3	71.1	56.0	-	-	138.7	21.8	98.4	83.0	67.5	52.1	-	-
	67	146.1	20.4	127.0	111.8	96.6	81.5	65.7	-	136.7	21.4	125.1	109.7	94.2	78.8	61.7	-
	62	135.2	20.4	131.3	131.3	117.0	101.8	86.7	71.5	126.9	21.4	126.9	126.9	113.1	97.7	82.3	66.8
4500	77	169.6	21.4	84.0	67.0	50.1	-	-	-	148.4	22.4	78.5	61.5	44.4	-	-	-
	72	162.6	21.1	112.8	95.8	78.8	61.8	-	-	146.5	22.1	108.6	91.6	74.5	57.5	-	-
	67	155.7	20.8	141.5	124.5	107.6	90.6	73.6	-	144.6	21.8	138.7	121.7	104.6	87.6	70.5	-
	62	144.0	20.7	139.8	139.8	129.8	112.9	95.9	78.9	134.3	21.7	134.3	134.3	125.4	108.3	91.2	74.2
57	143.6	20.6	139.4	139.4	125.8	108.8	91.9	74.9	134.4	21.7	134.4	134.4	120.3	103.2	86.2	69.1	-
5250	77	179.9	21.7	93.0	73.3	54.5	-	-	-	156.2	22.7	88.1	66.6	48.0	-	-	-
	72	172.6	21.4	124.1	105.3	86.5	67.7	-	-	154.4	22.4	118.8	100.2	81.5	62.8	-	-
	67	165.2	21.1	156.0	137.3	118.5	99.7	80.9	-	152.5	22.1	152.4	133.7	115.0	96.3	79.2	-
	62	152.9	21.0	148.4	148.4	142.5	123.9	105.1	86.3	141.7	22.0	141.7	141.7	137.6	118.9	100.2	81.5
57	152.4	20.9	148.0	148.0	138.2	119.4	100.7	81.9	141.8	22.0	141.8	141.8	132.0	113.3	94.6	76.0	-
6000	77	190.2	22.0	102.0	79.5	59.0	-	-	-	163.9	23.0	97.7	71.8	51.5	-	-	-
	72	182.5	21.7	135.3	114.8	94.2	73.6	-	-	162.2	22.7	129.1	108.8	88.5	68.2	-	-
	67	174.8	21.4	168.7	150.0	129.4	108.8	88.3	-	160.4	22.4	160.4	145.7	125.4	105.1	84.8	-
	62	161.8	21.3	157.0	157.0	155.2	134.9	114.3	93.7	149.0	22.3	149.0	149.0	149.0	129.5	109.2	88.9
57	161.2	21.2	156.5	156.5	150.6	130.1	109.5	88.9	149.2	22.3	149.2	149.2	143.7	123.4	103.1	82.8	-
6750	72	184.0	22.3	138.9	115.3	91.7	68.1	-	-	163.0	23.0	131.0	107.4	83.8	60.2	-	-
	67	182.2	22.4	170.9	153.1	128.4	105.9	82.2	-	161.1	22.9	161.1	147.2	120.4	100.0	76.4	-
	62	163.7	21.4	159.0	159.0	151.5	127.9	104.3	80.6	150.6	22.1	150.6	150.6	142.4	118.8	95.2	71.6
	57	163.2	21.3	158.5	158.5	147.0	123.3	99.7	76.1	150.9	22.1	150.9	150.9	137.1	113.5	89.9	66.3

1. These capacities are gross ratings. For net capacity, deduct air blower motor heat, MBh = 3.415 x kW.
2. Capacity ratings are based on 80°F (26.7°C) Entering Air Dry Bulb Temperature.
3. These ratings are total input kW, thus include the two condenser fan motors, compressor motors, and the supply air blower motor at 0.40" WC.

**ZF180 (15 Ton) Metric**

Air on Evaporator Coil		Temperature of Air on Condenser Coil																																	
		Total Capacity <sup>1,2</sup>	Total Input (kW) <sup>3</sup>	Sensible Capacity (MBh)						Total Capacity <sup>1,2</sup>	Total Input (kW) <sup>3</sup>	Sensible Capacity (MBh)																							
				Return Dry Bulb (°C)								Return Dry Bulb (°C)																							
				32	29	27	24	21	18			32	29	27	24	21	18																		
<b>29.4°C</b>																		<b>35°C</b>																	
1.77	25	69.3	15.8	29.7	25.4	21.1	-	-	-	59.8	17.5	26.6	22.5	18.3	-	-	-	1.77	25	69.3	15.8	29.7	25.4	21.1	-	-	-	59.8	17.5	26.6	22.5	18.3	-	-	-
	22	60.2	15.7	35.5	31.2	26.9	22.6	-	-	53.3	17.2	32.9	28.7	24.6	20.4	-	-		22	60.2	15.7	35.5	31.2	26.9	22.6	-	-	53.3	17.2	32.9	28.7	24.6	20.4	-	-
	19	51.1	15.5	41.3	37.0	32.7	28.4	24.1	-	46.9	16.9	39.2	35.0	30.8	26.7	22.5	-		19	51.1	15.5	41.3	37.0	32.7	28.4	24.1	-	46.9	16.9	39.2	35.0	30.8	26.7	22.5	-
	17	47.6	15.3	47.6	45.7	40.2	35.9	31.6	27.3	42.9	16.8	42.9	42.9	38.3	34.1	30.0	25.8		17	47.6	15.3	47.6	45.7	40.2	35.9	31.6	27.3	42.9	16.8	42.9	42.9	38.3	34.1	30.0	25.8
2.12	25	74.4	16.2	33.6	28.5	23.5	-	-	-	65.1	17.8	30.3	25.4	20.5	-	-	-	2.12	25	74.4	16.2	33.6	28.5	23.5	-	-	-	65.1	17.8	30.3	25.4	20.5	-	-	-
	22	64.6	16.1	40.0	35.0	30.0	25.0	-	-	58.0	17.5	37.3	32.4	27.6	22.7	-	-		22	64.6	16.1	40.0	35.0	30.0	25.0	-	-	58.0	17.5	37.3	32.4	27.6	22.7	-	-
	19	54.8	15.9	46.5	41.5	36.5	31.5	26.4	-	51.0	17.3	44.4	39.5	34.6	29.7	24.8	-		19	54.8	15.9	46.5	41.5	36.5	31.5	26.4	-	51.0	17.3	44.4	39.5	34.6	29.7	24.8	-
	17	51.1	15.7	51.1	49.9	44.9	39.8	34.8	29.8	46.7	17.1	46.7	46.7	42.7	37.8	32.9	28.0		17	51.1	15.7	51.1	49.9	44.9	39.8	34.8	29.8	46.7	17.1	46.7	46.7	42.7	37.8	32.9	28.0
2.48	25	79.5	16.6	37.5	31.7	26.0	-	-	-	70.4	18.1	34.0	28.4	22.8	-	-	-	2.48	25	79.5	16.6	37.5	31.7	26.0	-	-	-	70.4	18.1	34.0	28.4	22.8	-	-	-
	22	69.1	16.5	44.6	38.9	33.1	27.4	-	-	62.8	17.9	41.8	36.2	30.6	25.0	-	-		22	69.1	16.5	44.6	38.9	33.1	27.4	-	-	62.8	17.9	41.8	36.2	30.6	25.0	-	-
	19	58.6	16.3	51.8	46.0	40.3	34.5	28.8	-	55.2	17.6	49.5	43.9	38.3	32.7	27.1	-		19	58.6	16.3	51.8	46.0	40.3	34.5	28.8	-	55.2	17.6	49.5	43.9	38.3	32.7	27.1	-
	17	54.7	16.1	54.7	54.0	49.5	43.8	38.0	32.3	50.6	17.4	50.6	50.6	47.1	41.5	35.9	30.3		17	54.7	16.1	54.7	54.0	49.5	43.8	38.0	32.3	50.6	17.4	50.6	50.6	47.1	41.5	35.9	30.3
2.83	25	84.6	17.0	41.4	34.9	28.4	-	-	-	75.7	18.5	37.6	31.3	25.0	-	-	-	2.83	25	84.6	17.0	41.4	34.9	28.4	-	-	-	75.7	18.5	37.6	31.3	25.0	-	-	-
	22	73.5	16.9	49.2	42.7	36.2	29.8	-	-	67.5	18.2	46.2	39.9	33.5	27.2	-	-		22	73.5	16.9	49.2	42.7	36.2	29.8	-	-	67.5	18.2	46.2	39.9	33.5	27.2	-	-
	19	62.4	16.7	57.0	50.5	44.0	37.6	31.1	-	59.3	17.9	54.7	48.4	42.1	35.8	29.5	-		19	62.4	16.7	57.0	50.5	44.0	37.6	31.1	-	59.3	17.9	54.7	48.4	42.1	35.8	29.5	-
	17	58.2	16.5	58.2	58.2	54.2	47.7	41.2	34.7	54.4	17.7	54.4	54.4	51.5	45.1	38.8	32.5		17	58.2	16.5	58.2	58.2	54.2	47.7	41.2	34.7	54.4	17.7	54.4	54.4	51.5	45.1	38.8	32.5
3.19	25	74.7	17.9	51.4	44.3	37.1	30.0	-	-	68.6	19.5	49.0	42.0	35.1	28.1	-	-	3.19	25	74.7	17.9	51.4	44.3	37.1	30.0	-	-	68.6	19.5	49.0	42.0	35.1	28.1	-	-
	22	63.4	17.8	59.4	52.3	45.2	38.1	30.9	-	60.3	19.2	58.0	51.0	45.9	37.1	30.1	-		22	63.4	17.8	59.4	52.3	45.2	38.1	30.9	-	60.3	19.2	58.0	51.0	45.9	37.1	30.1	-
	19	59.1	17.5	59.1	59.1	55.5	48.4	41.3	34.2	55.2	19.0	55.2	55.2	53.8	46.9	39.9	33.0		19	59.1	17.5	59.1	59.1	55.5	48.4	41.3	34.2	55.2	19.0	55.2	55.2	53.8	46.9	39.9	33.0
	17	58.6	17.5	58.6	58.6	56.7	49.6	42.5	35.4	54.3	18.6	54.3	54.3	53.3	46.3	39.4	32.5		17	58.6	17.5	58.6	58.6	56.7	49.6	42.5	35.4	54.3	18.6	54.3	54.3	53.3	46.3	39.4	32.5
<b>40.6°C</b>																		<b>46.1°C</b>																	
1.77	25	53.6	19.0	24.8	20.5	16.2	-	-	-	47.4	20.6	22.9	18.5	14.1	-	-	-	1.77	25	53.6	19.0	24.8	20.5	16.2	-	-	-	47.4	20.6	22.9	18.5	14.1	-	-	-
	22	49.1	18.7	31.6	27.3	23.0	18.7	-	-	44.9	20.3	30.2	25.8	21.4	17.0	-	-		22	49.1	18.7	31.6	27.3	23.0	18.7	-	-	44.9	20.3	30.2	25.8	21.4	17.0	-	-
	19	44.6	18.4	38.3	34.0	29.8	25.5	21.2	-	42.3	19.9	37.5	33.1	28.7	24.3	19.9	-		19	44.6	18.4	38.3	34.0	29.8	25.5	21.2	-	42.3	19.9	37.5	33.1	28.7	24.3	19.9	-
	17	41.0	18.3	41.0	41.0	36.6	32.3	28.0	23.7	39.1	19.9	39.1	39.1	34.9	30.5	26.1	21.7		17	41.0	18.3	41.0	41.0	36.6	32.3	28.0	23.7	39.1	19.9	39.1	39.1	34.9	30.5	26.1	21.7
2.12	25	57.9	19.4	27.9	23.0	18.0	-	-	-	50.7	20.9	25.4	20.5	15.5	-	-	-	2.12	25	57.9	19.4	27.9	23.0	18.0	-	-	-	50.7	20.9	25.4	20.5	15.5	-	-	-
	22	53.0	19.1	35.5	30.6	25.7	20.7	-	-	48.0	20.6	33.7	28.7	23.7	18.8	-	-		22	53.0	19.1	35.5	30.6	25.7	20.7	-	-	48.0	20.6	33.7	28.7	23.7	18.8	-	-
	19	48.1	18.8	43.1	38.2	33.3	28.4	23.4	-	45.3	20.3	41.9	36.9	32.0	27.0	22.0	-		19	48.1	18.8	43.1	38.2	33.3	28.4	23.4	-	45.3	20.3	41.9	36.9	32.0	27.0	22.0	-
	17	44.3	18.6	44.3	44.3	40.7	35.8	30.9	25.9	41.8	20.2	41.8	41.8	38.7	33.8	28.8	23.8		17	44.3	18.6	44.3	44.3	40.7	35.8	30.9	25.9	41.8	20.2	41.8	41.8	38.7	33.8	28.8	23.8
2.48	25	62.2	19.7	31.0	25.4	19.9	-	-	-	54.0	21.2	28.0	22.5	17.0	-	-	-	2.48	25	62.2	19.7	31.0	25.4	19.9	-	-	-	54.0	21.2	28.0	22.5	17.0	-	-	-
	22	56.9	19.4	39.4	33.9	28.3	22.8	-	-	51.1	20.9	37.1	31.6	26.1	20.6	-	-		22	56.9	19.4	39.4	33.9	28.3	22.8	-	-	51.1	20.9	37.1	31.6	26.1	20.6	-	-
	19	51.7	19.1	47.9	42.4	36.8	31.2	25.7	-	48.2	20.6	46.3	40.8	35.2	29.7	24.2	-		19	51.7	19.1	47.9	42.4	36.8	31.2	25.7	-	48.2	20.6	46.3	40.8	35.2	29.7	24.2	-
	17	47.5	18.9	47.5	47.5	44.8	39.3	33.7	28.1	44.5	20.5	44.5	44.5	42.6	37.0	31.5	26.0		17	47.5	18.9	47.5	47.5	44.8	39.3	33.7	28.1	44.5	20.5	44.5	44.5	42.6	37.0	31.5	26.0
2.83	25	66.5	20.0	34.1	27.9	21.7	-	-	-	57.2	21.5	30.5	24.5	18.4	-	-	-	2.83	25	66.5	20.0	34.1	27.9	21.7	-	-	-	57.2	21.5	30.5	24.5	18.4	-	-	-
	22	60.8	19.7	43.4	37.2	31.0	24.8	-	-	54.2	21.2	40.6	34.5	28.5	22.4	-	-		22	60.8	19.7	43.4	37.2	31.0	24.8	-	-	54.2	21.2	40.6	34.5	28.5	22.4	-	-
	19	55.2	19.4	52.7	46.5	40.3	34.1	27.9	-	51.1	20.9	50.7	44.6	38.5	32.5	26.4	-		19	55.2	19.4	52.7	46.5	40.3	34.1	27.9	-	51.1	20.9	50.7	44.6	38.5	32.5	26.4	-
	17	50.8	19.2	50.8	50.8	48.9	42.7	36.5	30.4	47.2	20.8	47.2	47.2	46.4	40.3	34.3	28.2		17	50.8	19.2	50.8	50.8	48.9	42.7	36.5	30.4	47.2	20.8	47.2	47.2	46.4	40.3	34.3	28.2
3.19	25	61.7	20.7	45.4	38.5	31.6	24.6	-	-	54.7	21.9	41.9	35.0	28.1	21.1	-	-	3.19	25	61.7	20.7	45.4	38.5	31.6	24.6	-	-	54.7	21.9	41.9	35.0	28.1	21.1	-	-
	22	55.9	20.4	54.8	48.3	42.4	34.5	27.6	-	51.6	21.7	51.6	45.7	38.8	31.9	25.0	-		22	55.9	20.4	54.8	48.3	42.4	34.5	27.6	-	51.6	21.7	51.6	45.7	38.8	31.9	25.0	-
	19	51.5	20.0	51.5	51.5	49.8	42.8	35.9	29.0	47.8	21.1	47.8	47.8	45.8	38.8	31.9	25.0		19	51.5	20.0	51.5	51.5	49.8	42.8	35.9	29.0	47.8	21.1	47.8	47.8	45.8	38.8	31.9	25.0
	17	51.0	19.8	51.0	51.0	48.9	42.0	35.0	28.1	47.6	20.9	47.6	47.6	44.5	37.6	30.7	23.8		17	51.0	19.8	51.0	51.0	48.9	42.0	35.0	28.1	47.6	20.9	47.6	47.6	44.5	37.6	30.7	23.8

**ZF180 (15 Ton) Metric**

Air on Evaporator Coil		Temperature of Air on Condenser Coil															
		Total Capacity <sup>1,2</sup>	Total Input (kW) <sup>3</sup>	Sensible Capacity (MBh)						Total Capacity <sup>1,2</sup>	Total Input (kW) <sup>3</sup>	Sensible Capacity (MBh)					
				Return Dry Bulb (°C)								Return Dry Bulb (°C)					
				32	29	27	24	21	18			32	29	27	24	21	18
		48°C								51.7°C							
1.77	25	46.7	21.1	22.0	17.8	13.4	-	-	-	41.2	22.1	20.2	16.5	12.0	-	-	-
	22	44.7	20.8	29.7	25.3	20.8	16.4	-	-	40.6	21.8	28.8	24.3	19.8	15.3	-	-
	19	42.8	20.4	37.2	32.8	28.3	23.9	19.3	-	40.1	21.4	36.7	32.1	27.6	23.1	18.1	-
	17	39.6	20.4	38.5	38.5	34.3	29.8	25.4	20.9	37.2	21.4	37.2	37.2	33.2	28.6	24.1	19.6
2.12	25	49.7	21.4	24.6	19.6	14.7	-	-	-	43.5	22.4	23.0	18.0	13.0	-	-	-
	22	47.6	21.1	33.0	28.1	23.1	18.1	-	-	42.9	22.1	31.8	26.8	21.8	16.8	-	-
	19	45.6	20.8	41.5	36.5	31.5	26.5	21.6	-	42.4	21.8	40.6	35.6	30.7	25.7	20.7	-
	17	42.2	20.7	41.0	41.0	38.0	33.1	28.1	23.1	39.3	21.7	39.3	39.3	36.7	31.7	26.7	21.7
2.48	25	52.7	21.7	27.3	21.5	16.0	-	-	-	45.8	22.7	25.8	19.5	14.1	-	-	-
	22	50.6	21.4	36.3	30.8	25.3	19.8	-	-	45.2	22.4	34.8	29.3	23.9	18.4	-	-
	19	48.4	21.1	45.7	40.2	34.7	29.2	23.7	-	44.7	22.1	44.6	39.2	33.7	28.2	23.2	-
	17	44.8	21.0	43.5	43.5	41.8	36.3	30.8	25.3	41.5	22.0	41.5	41.5	40.3	34.8	29.4	23.9
2.83	25	55.7	22.0	29.9	23.3	17.3	-	-	-	48.0	23.0	28.6	21.0	15.1	-	-	-
	22	53.5	21.7	39.7	33.6	27.6	21.6	-	-	47.5	22.7	37.8	31.9	25.9	20.0	-	-
	19	51.2	21.4	49.4	43.9	37.9	31.9	25.9	-	47.0	22.4	47.0	42.7	36.7	30.8	24.8	-
	17	47.4	21.3	46.0	46.0	45.5	39.5	33.5	27.5	43.7	22.3	43.7	43.7	43.7	37.9	32.0	26.0
3.19	25	53.9	22.3	40.7	33.8	26.9	19.9	-	-	47.8	23.0	38.4	31.5	24.6	17.6	-	-
	22	53.4	22.4	50.1	44.9	37.6	31.0	24.1	-	47.2	22.9	47.2	43.1	35.3	29.3	22.4	-
	19	48.0	21.4	46.6	46.6	44.4	37.5	30.5	23.6	44.1	22.1	44.1	44.1	41.7	34.8	27.9	21.0
	17	47.8	21.3	46.4	46.4	43.1	36.1	29.2	22.3	44.2	22.1	44.2	44.2	40.2	33.3	26.4	19.4

1. These capacities are gross ratings. For net capacity, deduct air blower motor heat, MBh = 3.415 x kW.
2. Capacity ratings are based on 80°F (26.7°C) Entering Air Dry Bulb Temperature.
3. These ratings are total input kW, thus include the two condenser fan motors, compressor motors, and the supply air blower motor at 0.40" WC.

ZF240 (20 Ton) Imperial

Air on Evaporator Coil		Temperature of Air on Condenser Coil																		
CFM	WB (°F)	Total Capacity <sup>1,2</sup> (kW)	Total Input (kW) <sup>3</sup>	Sensible Capacity (MBh)						Total Capacity <sup>1,2</sup> (MBh)	Total Input (kW) <sup>3</sup>	Sensible Capacity (MBh)								
				Return Dry Bulb (°F)								Return Dry Bulb (°F)								
				90	85	80	75	70	65			90	85	80	75	70	65			
				85°F								95°F								
5000	77	241.7	20.5	114.0	93.5	73.0	-	-	-	221.4	22.7	105.3	84.8	64.4	-	-	-			
	72	236.0	20.2	153.9	133.3	112.8	92.3	-	-	217.3	22.2	144.4	124.0	103.6	83.2	-	-			
	67	230.2	20.0	193.7	173.2	152.6	132.1	111.6	-	213.1	21.8	183.6	163.2	142.8	122.3	101.9	-			
	62	216.8	19.6	216.8	214.4	186.2	165.7	145.2	124.7	193.7	21.5	193.7	193.7	172.1	151.7	131.3	110.8			
6000	77	254.5	21.2	126.1	102.9	79.7	-	-	-	237.5	23.4	118.2	95.0	71.8	-	-	-			
	72	248.4	20.9	169.6	146.4	123.2	100.0	-	-	233.0	22.9	161.8	138.6	115.4	92.2	-	-			
	67	242.3	20.6	213.2	189.9	166.7	143.5	120.3	-	228.5	22.4	205.5	182.3	159.1	135.9	112.7	-			
	62	228.2	20.3	228.2	226.6	203.4	180.2	157.0	133.8	207.7	22.1	207.7	207.7	192.2	169.0	145.9	122.7			
7000	77	267.2	21.8	138.2	112.3	86.4	-	-	-	253.5	24.1	131.1	105.1	79.1	-	-	-			
	72	260.9	21.6	185.4	159.5	133.6	107.7	-	-	248.7	23.6	179.2	153.2	127.3	101.3	-	-			
	67	254.5	21.3	232.6	206.7	180.8	154.9	129.0	-	244.0	23.1	227.3	201.3	175.4	149.4	123.5	-			
	62	239.7	20.9	239.7	238.9	220.6	194.7	168.8	142.9	221.8	22.8	221.8	221.8	212.4	186.4	160.4	134.5			
8000	77	280.0	22.5	150.4	121.8	93.2	-	-	-	269.5	24.7	144.0	115.2	86.5	-	-	-			
	72	273.3	22.2	201.2	172.6	144.0	115.4	-	-	264.5	24.2	196.6	167.8	139.1	110.4	-	-			
	67	266.6	22.0	252.1	223.5	194.9	166.3	137.7	-	259.4	23.7	249.2	220.4	191.7	163.0	134.3	-			
	62	251.1	21.6	251.1	251.1	237.8	209.2	180.6	152.0	235.8	23.4	235.8	235.8	232.5	203.8	175.0	146.3			
8800	77	241.9	21.4	241.9	241.9	241.9	213.3	184.7	156.1	230.9	23.6	230.9	230.9	230.9	202.1	173.4	144.7			
	72	289.0	23.7	223.2	191.0	158.8	126.5	-	-	269.4	25.7	216.9	184.3	151.7	119.0	-	-			
	67	281.5	23.0	274.7	247.0	214.8	182.6	150.4	-	264.2	25.0	259.2	241.6	209.0	176.4	143.8	-			
	62	265.5	22.4	265.5	265.5	258.9	226.7	194.5	162.2	240.2	24.3	240.2	240.2	238.6	205.9	173.3	140.7			
8800	57	255.8	22.0	255.8	255.8	255.8	223.6	191.4	159.1	235.2	24.2	235.2	235.2	235.2	202.6	170.0	137.4			
					105°F								115°F							
	5000	77	209.3	24.3	95.9	79.0	58.8	-	-	-	197.1	25.9	86.5	73.1	53.3	-	-	-		
		72	204.3	24.0	137.8	117.6	97.5	77.3	-	-	191.3	25.8	131.1	111.3	91.4	71.5	-	-		
67		199.3	23.7	179.7	156.3	136.1	116.0	95.8	-	185.4	25.6	175.7	149.4	129.5	109.6	89.7	-			
62		184.0	23.3	184.0	184.0	161.3	141.2	121.0	100.9	174.3	25.2	174.3	174.3	150.6	130.7	110.8	90.9			
6000	77	223.3	25.0	111.8	88.8	65.8	-	-	-	209.2	26.6	105.4	82.6	59.8	-	-	-			
	72	218.0	24.7	154.8	131.8	108.8	85.8	-	-	203.0	26.4	147.9	125.0	102.2	79.4	-	-			
	67	212.7	24.3	197.9	174.9	151.9	128.8	105.8	-	196.8	26.3	190.3	167.5	144.6	121.8	99.0	-			
	62	196.4	24.0	196.4	196.4	180.3	157.3	134.3	111.3	185.0	25.9	185.0	185.0	168.4	145.5	122.7	99.8			
7000	57	193.7	24.0	193.7	193.7	180.2	157.1	134.1	111.1	184.1	25.9	184.1	184.1	169.4	146.6	123.7	100.9			
	77	237.4	25.7	127.7	98.6	72.7	-	-	-	221.2	27.3	124.3	92.0	66.2	-	-	-			
	72	231.7	25.4	171.9	146.0	120.1	94.3	-	-	214.7	27.1	164.6	138.8	113.0	87.2	-	-			
	67	226.0	25.0	216.1	193.5	167.6	141.7	115.8	-	208.1	26.9	204.9	185.6	159.8	134.0	108.2	-			
8000	62	208.7	24.7	208.7	208.7	199.3	173.4	147.5	121.6	195.6	26.7	195.6	195.6	186.2	160.4	134.6	108.8			
	57	205.9	24.8	205.9	205.9	199.1	173.2	147.4	121.5	194.7	26.7	194.7	194.7	187.3	161.5	135.7	109.9			
	77	251.4	26.4	143.6	108.4	79.6	-	-	-	233.3	28.0	143.2	101.5	72.7	-	-	-			
	72	245.4	26.0	189.0	160.2	131.5	102.7	-	-	226.4	27.8	181.3	152.6	123.8	95.1	-	-			
8800	67	239.4	25.7	234.3	212.0	183.3	154.6	125.8	-	219.5	27.6	219.5	203.7	174.9	146.1	117.4	-			
	62	221.0	25.5	221.0	221.0	218.2	189.5	160.8	132.0	206.3	27.5	206.3	206.3	204.0	175.3	146.5	117.7			
	57	218.1	25.5	218.1	218.1	218.1	189.3	160.6	131.8	205.3	27.5	205.3	205.3	205.3	176.5	147.7	119.0			
	72	252.4	27.2	204.4	171.9	139.4	106.8	-	-	235.4	28.7	191.8	159.4	127.0	94.7	-	-			
8800	67	243.7	26.8	240.7	228.0	196.3	163.8	131.3	-	223.2	28.6	222.3	214.4	183.6	151.2	118.8	-			
	62	224.6	26.1	224.6	224.6	223.2	190.7	158.2	125.7	209.0	27.9	209.0	209.0	207.8	175.5	143.1	110.7			
	57	221.6	26.0	221.6	221.6	221.6	189.1	156.6	124.1	207.9	27.9	207.9	207.9	207.9	175.6	143.2	110.8			

**ZF240 (20 Ton) Imperial (Continued)**

Air on Evaporator Coil		Temperature of Air on Condenser Coil															
		Total Capacity <sup>1,2</sup>	Total Input (kW) <sup>3</sup>	Sensible Capacity (MBh)						Total Capacity <sup>1,2</sup>	Total Input (kW) <sup>3</sup>	Sensible Capacity (MBh)					
				Return Dry Bulb (°F)								Return Dry Bulb (°F)					
				90	85	80	75	70	65			90	85	80	75	70	65
		118.4°F								125°F							
5000	77	192.2	26.4	82.6	71.0	51.4	-	-	-	182.6	27.2	75.0	67.0	47.7	-	-	-
	72	186.9	26.4	128.9	109.1	89.3	69.5	-	-	178.3	27.5	124.5	104.9	85.3	65.7	-	-
	67	180.7	26.2	174.3	147.0	127.2	107.5	86.8	-	171.6	27.5	171.6	142.5	122.9	103.3	81.2	-
	62	171.0	25.8	171.0	171.0	146.9	127.1	107.3	87.5	164.6	27.0	164.6	164.6	139.8	120.2	100.5	80.9
6000	77	204.4	27.2	103.9	80.5	57.7	-	-	-	195.0	28.3	100.9	76.4	53.7	-	-	-
	72	197.9	27.0	145.5	122.7	99.9	77.2	-	-	188.0	28.2	140.9	118.2	95.6	72.9	-	-
	67	191.4	26.9	187.1	165.0	142.2	119.4	96.6	-	180.9	28.2	180.9	160.1	137.4	114.8	92.1	-
	62	181.1	26.6	181.1	181.1	164.3	141.5	118.8	96.0	173.6	27.9	173.6	173.6	156.4	133.8	111.1	88.4
57	180.1	26.6	180.1	180.1	165.7	143.0	120.2	97.4	172.4	27.8	172.4	172.4	158.6	136.0	113.3	90.7	
7000	77	216.6	28.0	125.2	89.9	64.1	-	-	-	207.5	29.3	126.8	85.8	59.8	-	-	-
	72	208.9	27.7	162.1	136.4	110.6	84.8	-	-	197.6	28.9	157.3	131.6	105.9	80.2	-	-
	67	202.0	27.6	199.9	182.9	157.1	131.3	105.6	-	190.2	28.9	190.2	177.7	152.0	126.2	103.0	-
	62	191.2	27.4	191.2	191.2	181.7	156.0	130.2	104.4	182.6	28.7	182.6	182.6	173.1	147.4	121.7	95.9
57	190.8	27.4	190.8	190.8	183.0	157.6	131.8	106.0	183.4	28.7	183.4	183.4	175.5	149.8	124.1	98.4	
8000	77	228.8	28.8	146.5	99.4	70.4	-	-	-	220.0	30.3	152.8	95.2	65.9	-	-	-
	72	219.9	28.6	178.8	150.0	121.2	92.5	-	-	207.3	30.1	173.7	145.0	116.2	87.4	-	-
	67	211.0	28.4	211.0	200.6	172.0	143.3	114.5	-	194.7	29.9	194.7	194.7	166.5	137.7	109.0	-
	62	201.3	28.2	201.3	201.3	199.2	170.4	141.6	112.9	191.5	29.6	191.5	191.5	189.8	161.0	132.2	103.5
57	200.2	28.2	200.2	200.2	200.2	172.1	143.4	114.6	190.3	29.5	190.3	190.3	190.3	163.7	134.9	106.1	
8800	72	229.6	29.4	187.6	155.2	122.9	90.5	-	-	218.4	30.9	179.3	147.0	114.7	82.5	-	-
	67	221.5	28.9	215.7	209.8	179.2	146.9	114.5	-	202.8	30.8	202.8	200.8	170.8	138.6	106.3	-
	62	203.7	28.7	203.7	203.7	202.6	170.3	137.9	105.6	193.4	30.1	193.4	193.4	192.5	160.2	127.9	95.7
	57	202.2	28.6	202.2	202.2	202.2	171.0	138.6	106.2	191.0	30.1	191.0	191.0	191.0	162.0	129.8	97.5

1. These capacities are gross ratings. For net capacity, deduct air blower motor heat, MBh = 3.415 x kW.
2. Capacity ratings are based on 80°F (26.7°C) Entering Air Dry Bulb Temperature.
3. These ratings are total input kW, thus include the two condenser fan motors, compressor motors, and the supply air blower motor at 0.40" WC.

ZF240 (20 Ton) Metric

Air on Evaporator Coil		Temperature of Air on Condenser Coil															
M <sup>3</sup> /sec	WB (°C)	Total Capacity <sup>1,2</sup> (kW)	Total Input (kW) <sup>3</sup>	Sensible Capacity (MBh)						Total Capacity <sup>1,2</sup> (MBh)	Total Input (kW) <sup>3</sup>	Sensible Capacity (MBh)					
				Return Dry Bulb (°C)								Return Dry Bulb (°C)					
				32	29	27	24	21	18			32	29	27	24	21	18
				29.4°C						35°C							
2.36	25	70.8	20.5	33.4	27.4	21.4	-	-	-	64.9	22.7	30.8	24.9	18.9	-	-	-
	22	69.1	20.2	45.1	39.1	33.1	27.0	-	-	63.7	22.2	42.3	36.3	30.4	24.4	-	-
	19	67.4	20.0	56.8	50.7	44.7	38.7	32.7	-	62.4	21.8	53.8	47.8	41.8	35.8	29.9	-
	17	63.5	19.6	63.5	62.8	54.6	48.6	42.5	36.5	56.8	21.5	56.8	56.8	50.4	44.4	38.5	32.5
2.83	25	74.6	21.2	37.0	30.2	23.3	-	-	-	69.6	23.4	34.6	27.8	21.0	-	-	-
	22	72.8	20.9	49.7	42.9	36.1	29.3	-	-	68.3	22.9	47.4	40.6	33.8	27.0	-	-
	19	71.0	20.6	62.5	55.7	48.9	42.0	35.2	-	67.0	22.4	60.2	53.4	46.6	39.8	33.0	-
	17	66.9	20.3	66.9	66.4	59.6	52.8	46.0	39.2	60.9	22.1	60.9	60.9	56.3	49.5	42.7	35.9
3.30	25	78.3	21.8	40.5	32.9	25.3	-	-	-	74.3	24.1	38.4	30.8	23.2	-	-	-
	22	76.4	21.6	54.3	46.7	39.1	31.6	-	-	72.9	23.6	52.5	44.9	37.3	29.7	-	-
	19	74.6	21.3	68.2	60.6	53.0	45.4	37.8	-	71.5	23.1	66.6	59.0	51.4	43.8	36.2	-
	17	70.2	20.9	70.2	70.0	64.6	57.0	49.5	41.9	65.0	22.8	65.0	65.0	62.2	54.6	47.0	39.4
3.78	25	82.0	22.5	44.1	35.7	27.3	-	-	-	79.0	24.7	42.2	33.8	25.3	-	-	-
	22	80.1	22.2	59.0	50.6	42.2	33.8	-	-	77.5	24.2	57.6	49.2	40.8	32.3	-	-
	19	78.1	22.0	73.9	65.5	57.1	48.7	40.3	-	76.0	23.7	73.0	64.6	56.2	47.8	39.3	-
	17	73.6	21.6	73.6	73.6	69.7	61.3	52.9	44.5	69.1	23.4	69.1	69.1	68.1	59.7	51.3	42.9
4.15	25	84.7	23.7	65.4	56.0	46.5	37.1	-	-	78.9	25.7	63.5	54.0	44.4	34.9	-	-
	22	82.5	23.0	80.5	72.4	62.9	53.5	44.1	-	77.4	25.0	75.9	70.8	61.2	51.7	42.1	-
	19	77.8	22.4	77.8	77.8	75.9	66.4	57.0	47.5	70.4	24.3	70.4	70.4	69.9	60.3	50.8	41.2
	17	74.9	22.0	74.9	74.9	74.9	65.5	56.1	46.6	68.9	24.2	68.9	68.9	68.9	59.4	49.8	40.2
				40.6°C						46.1°C							
2.36	25	61.3	24.3	28.1	23.1	17.2	-	-	-	57.8	25.9	25.4	21.4	15.6	-	-	-
	22	59.9	24.0	40.4	34.5	28.6	22.7	-	-	56.0	25.8	38.4	32.6	26.8	20.9	-	-
	19	58.4	23.7	52.6	45.8	39.9	34.0	28.1	-	54.3	25.6	51.5	43.8	37.9	32.1	26.3	-
	17	53.9	23.3	53.9	53.9	47.3	41.4	35.5	29.6	51.1	25.2	51.1	51.1	44.1	38.3	32.5	26.6
2.83	25	65.4	25.0	32.8	26.0	19.3	-	-	-	61.3	26.6	30.9	24.2	17.5	-	-	-
	22	63.9	24.7	45.4	38.6	31.9	25.1	-	-	59.5	26.4	43.3	36.6	29.9	23.2	-	-
	19	62.3	24.3	58.0	51.2	44.5	37.7	31.0	-	57.7	26.3	55.8	49.1	42.4	35.7	29.0	-
	17	57.5	24.0	57.5	57.5	52.8	46.1	39.3	32.6	54.2	25.9	54.2	54.2	49.3	42.6	35.9	29.3
3.30	25	69.5	25.7	37.4	28.9	21.3	-	-	-	64.8	27.3	36.4	27.0	19.4	-	-	-
	22	67.9	25.4	50.4	42.8	35.2	27.6	-	-	62.9	27.1	48.2	40.7	33.1	25.6	-	-
	19	66.2	25.0	63.3	56.7	49.1	41.5	33.9	-	61.0	26.9	60.0	54.4	46.8	39.3	31.7	-
	17	61.1	24.7	61.1	61.1	58.4	50.8	43.2	35.6	57.3	26.7	57.3	57.3	54.6	47.0	39.4	31.9
3.78	25	73.7	26.4	42.1	31.8	23.3	-	-	-	68.4	28.0	42.0	29.7	21.3	-	-	-
	22	71.9	26.0	55.4	46.9	38.5	30.1	-	-	66.3	27.8	53.1	44.7	36.3	27.9	-	-
	19	70.2	25.7	68.7	62.1	53.7	45.3	36.9	-	64.3	27.6	64.3	59.7	51.2	42.8	34.4	-
	17	64.8	25.5	64.8	64.8	63.9	55.5	47.1	38.7	60.4	27.5	60.4	60.4	59.8	51.3	42.9	34.5
4.15	25	74.0	27.2	59.9	50.4	40.8	31.3	-	-	69.0	28.7	56.2	46.7	37.2	27.7	-	-
	22	71.4	26.8	70.5	66.8	57.5	48.0	38.5	-	65.4	28.6	65.1	62.8	53.8	44.3	34.8	-
	19	65.8	26.1	65.8	65.8	65.4	55.9	46.4	36.8	61.2	27.9	61.2	61.2	60.9	51.4	41.9	32.4
	17	64.9	26.0	64.9	64.9	64.9	55.4	45.9	36.4	60.9	27.9	60.9	60.9	60.9	51.4	41.9	32.5

ZF240 (20 Ton) Metric (Continued)

Air on Evaporator Coil		Temperature of Air on Condenser Coil															
		Total Capacity <sup>1,2</sup>	Total Input (kW) <sup>3</sup>	Sensible Capacity (MBh)						Total Capacity <sup>1,2</sup>	Total Input (kW) <sup>3</sup>	Sensible Capacity (MBh)					
				Return Dry Bulb (°C)								Return Dry Bulb (°C)					
				32	29	27	24	21	18			32	29	27	24	21	18
		48°C								51.7°C							
2.36	25	56.3	26.4	24.2	20.8	15.0	-	-	-	53.5	27.2	22.0	19.6	14.0	-	-	-
	22	54.8	26.4	37.8	32.0	26.2	20.4	-	-	52.2	27.5	36.5	30.7	25.0	19.2	-	-
	19	53.0	26.2	51.1	43.1	37.3	31.5	25.4	-	50.3	27.5	50.3	41.7	36.0	30.3	23.8	-
	17	50.1	25.8	50.1	50.1	43.0	37.2	31.4	25.6	48.2	27.0	48.2	48.2	41.0	35.2	29.5	23.7
2.83	25	59.9	27.2	30.4	23.6	16.9	-	-	-	57.1	28.3	29.6	22.4	15.7	-	-	-
	22	58.0	27.0	42.6	36.0	29.3	22.6	-	-	55.1	28.2	41.3	34.6	28.0	21.4	-	-
	19	56.1	26.9	54.8	48.3	41.7	35.0	28.3	-	53.0	28.2	53.0	46.9	40.3	33.6	27.0	-
	17	53.1	26.6	53.1	53.1	48.1	41.5	34.8	28.1	50.9	27.9	50.9	50.9	45.8	39.2	32.6	25.9
3.30	25	63.5	28.0	36.7	26.3	18.8	-	-	-	60.8	29.3	37.2	25.1	17.5	-	-	-
	22	61.2	27.7	47.5	40.0	32.4	24.8	-	-	57.9	28.9	46.1	38.6	31.0	23.5	-	-
	19	59.2	27.6	58.6	53.6	46.0	38.5	30.9	-	55.7	28.9	55.7	52.1	44.5	37.0	30.2	-
	17	56.0	27.4	56.0	56.0	53.3	45.7	38.1	30.6	53.5	28.7	53.5	53.5	50.7	43.2	35.6	28.1
3.78	25	67.0	28.8	42.9	29.1	20.6	-	-	-	64.4	30.3	44.8	27.9	19.3	-	-	-
	22	64.4	28.6	52.4	43.9	35.5	27.1	-	-	60.7	30.1	50.9	42.5	34.0	25.6	-	-
	19	61.8	28.4	61.8	58.8	50.4	42.0	33.6	-	57.0	29.9	57.0	57.0	48.8	40.4	31.9	-
	17	59.0	28.2	59.0	59.0	58.4	49.9	41.5	33.1	56.1	29.6	56.1	56.1	55.6	47.2	38.7	30.3
4.15	25	67.3	29.4	55.0	45.5	36.0	26.5	-	-	64.0	30.9	52.5	43.1	33.6	24.2	-	-
	22	64.9	28.9	63.2	61.5	52.5	43.0	33.6	-	59.4	30.8	59.4	58.8	50.1	40.6	31.1	-
	19	59.7	28.7	59.7	59.7	59.4	49.9	40.4	30.9	56.7	30.1	56.7	56.7	56.4	46.9	37.5	28.0
	17	59.2	28.6	59.2	59.2	59.2	50.1	40.6	31.1	56.0	30.1	56.0	56.0	56.0	47.5	38.0	28.6

1. These capacities are gross ratings. For net capacity, deduct air blower motor heat, MBh = 3.415 x kW.
2. Capacity ratings are based on 80°F (26.7°C) Entering Air Dry Bulb Temperature.
3. These ratings are total input kW, thus include the two condenser fan motors, compressor motors, and the supply air blower motor at 0.40" WC.

## Airflow Performance

### ZF180-240 Side Duct Application

#### ZF180 (15 Ton) Side Duct Imperial

Air Flow (CFM)	Available External Static Pressure - IWG <sup>1</sup>																									
	0.4		0.6		0.8		1.0		1.2		1.4		1.6		1.8		2.0		2.2		2.4		2.6			
	RPM	BHP	RPM	BHP	RPM	BHP	RPM	BHP	RPM	BHP	RPM	BHP	RPM	BHP	RPM	BHP	RPM	BHP	RPM	BHP	RPM	BHP	RPM	BHP	RPM	BHP
	High Static 4.0 HP & Field Supplied Drive							High Static 4.0 HP & OEM Supplied Drive																		
4400	760	1.56	798	1.90	835	2.20	878	2.47	950	2.81	1014	3.11	1069	3.38	1115	3.61	1154	3.81	1184	3.97	1205	4.09	1218	4.18		
4800	786	1.93	824	2.27	861	2.57	904	2.84	976	3.18	1040	3.48	1095	3.75	1142	3.98	1180	4.18	1210	4.34	1231	4.46	1244	4.55		
5200	815	2.34	853	2.68	890	2.98	933	3.25	1005	3.59	1068	3.89	1123	4.16	1170	4.39	1208	4.59	1238	4.75	1260	4.87	1273	4.96		
5600	845	2.79	883	3.13	920	3.43	963	3.70	1035	4.04	1099	4.34	1154	4.61	1200	4.84	1239	5.04	1269	5.20	1290	5.32	1303	5.41		
6000	877	3.28	915	3.62	952	3.92	995	4.19	1067	4.53	1131	4.83	1186	5.10	1232	5.33	1271	5.53	-	-	-	-	-	-	-	-
6400	911	3.81	949	4.15	986	4.45	1029	4.72	1101	5.06	1164	5.36	1219	5.63	-	-	-	-	-	-	-	-	-	-	-	-
6800	946	4.38	984	4.72	1021	5.02	1064	5.29	-	-	-	-	-	-	-	-	-	-	-	-	-	-	-	-	-	-
7200	982	4.98	1020	5.32	1057	5.62	-	-	-	-	-	-	-	-	-	-	-	-	-	-	-	-	-	-	-	-
	Field Supplied Motor & Drive																									

1. Blower performance includes gas heat exchangers and 2" filters. See STATIC RESISTANCE table for additional applications.
2. See RPM SELECTION table to determine desired motor sheave setting and to determine the maximum continuous BHP.
3. kW = BHP x 0.838.

#### ZF180 (15 Ton) Side Duct Metric

Air Flow M <sup>3</sup> /sec.	Available External Static Pressure - Pa <sup>1</sup>																									
	100		149		199		249		299		349		399		448		498		548		598		648			
	RPM	kW	RPM	kW	RPM	kW	RPM	kW	RPM	kW	RPM	kW	RPM	kW	RPM	kW	RPM	kW	RPM	kW	RPM	kW	RPM	kW	RPM	kW
	High Static 4.0 HP & Field Supplied Drive							High Static 4.0 HP & OEM Drive																		
2.08	760	1.16	798	1.42	835	1.64	878	1.84	950	2.09	1014	2.32	1069	2.52	1115	2.69	1154	2.84	1184	2.96	1205	3.50	1218	3.12		
2.27	786	1.44	824	1.69	861	1.92	904	2.12	976	2.37	1040	2.60	1095	2.80	1142	2.97	1180	3.12	1210	3.24	1231	3.33	1244	2.39		
2.45	815	1.75	853	2.00	890	2.22	933	2.42	1005	2.68	1068	2.90	1123	3.10	1170	3.27	1208	3.42	1238	3.54	1260	3.63	1273	3.70		
2.64	845	2.08	883	2.33	920	2.56	963	2.76	1035	3.01	1099	3.24	1154	3.44	1200	3.61	1239	3.76	1269	3.88	1290	3.97	1303	4.03		
2.83	877	2.45	915	2.70	952	2.92	995	3.12	1067	3.38	1131	3.60	1186	3.80	1232	3.97	1271	4.12	-	-	-	-	-	-	-	-
3.02	911	2.84	949	3.10	986	3.32	1029	3.52	1101	3.77	1164	4.00	1219	4.20	-	-	-	-	-	-	-	-	-	-	-	-
3.21	946	3.27	984	3.52	1021	3.74	1064	3.94	-	-	-	-	-	-	-	-	-	-	-	-	-	-	-	-	-	-
3.40	982	3.71	1020	3.97	1057	4.19	-	-	-	-	-	-	-	-	-	-	-	-	-	-	-	-	-	-	-	-
	Field Supplied Motor & Drive																									

1. Blower performance includes gas heat exchangers and 2" filters. See STATIC RESISTANCE table for additional applications.
2. See RPM SELECTION table to determine desired motor sheave setting and to determine the maximum continuous BHP.

**ZF240 (20 Ton) Side Duct Imperial**

Air Flow (CFM)	Available External Static Pressure - IWG <sup>1</sup>																							
	0.4		0.6		0.8		1.0		1.2		1.4		1.6		1.8		2.0		2.2		2.4		2.6	
	RPM	BHP	RPM	BHP	RPM	BHP	RPM	BHP	RPM	BHP	RPM	BHP	RPM	BHP	RPM	BHP	RPM	BHP	RPM	BHP	RPM	BHP	RPM	BHP
	High Static 6.3 HP & Field Supplied Drive												High Static 6.3 HP & OEM Drive											
5200	678	1.35	715	1.83	751	2.28	787	2.70	823	3.09	858	3.43	892	3.74	925	3.99	957	4.19	987	4.33	1015	4.41	1042	4.42
5600	697	1.74	733	2.22	770	2.67	806	3.09	842	3.48	876	3.82	911	4.13	944	4.38	975	4.58	1005	4.72	1034	4.80	1060	4.82
6000	717	2.17	754	2.65	790	3.10	826	3.52	862	3.90	897	4.25	931	4.55	964	4.81	996	5.01	1026	5.15	1054	5.23	1081	5.24
6400	740	2.64	776	3.11	812	3.57	848	3.99	884	4.37	919	4.72	953	5.02	986	5.28	1018	5.48	1048	5.62	1076	5.70	1103	5.71
6800	763	3.15	800	3.63	836	4.08	872	4.50	908	4.88	943	5.23	977	5.53	1010	5.79	1042	5.99	1072	6.13	1100	6.21	1127	6.22
7200	789	3.71	825	4.18	861	4.63	898	5.05	933	5.44	968	5.79	1002	6.09	1035	6.34	1067	6.55	1097	6.69	1126	6.77	1152	6.78
7600	815	4.31	852	4.79	888	5.24	924	5.66	960	6.04	995	6.39	1029	6.69	1062	6.95	1094	7.15	1124	7.29	1152	7.37	1179	7.38
8000	844	4.96	880	5.44	916	5.89	952	6.31	988	6.70	1023	7.04	1057	7.34	1090	7.60	1122	7.80	1152	7.94	1180	8.02	-	-
8400	873	5.66	909	6.13	946	6.59	982	7.01	1018	7.39	1053	7.74	1087	8.04	1120	8.30	1151	8.50	1182	8.64	-	-	-	-
8800	904	6.40	940	6.88	977	7.33	1013	7.75	1048	8.14	1083	8.48	1117	8.79	-	-	-	-	-	-	-	-	-	-
9200	936	7.19	972	7.67	1009	8.12	1045	8.54	1080	8.93	-	-	-	-	-	-	-	-	-	-	-	-	-	-
9600	969	8.03	1005	8.50	1042	8.96	-	-	-	-	-	-	-	-	-	-	-	-	-	-	-	-	-	-
10000	1003	8.91	-	-	-	-	-	-	-	-	-	-	-	-	-	-	-	-	-	-	-	-	-	-

Field Supplied Motor & Drive

1. Blower performance includes gas heat exchangers and 2" filters. See STATIC RESISTANCE table for additional applications.
2. See RPM SELECTION table to determine desired motor sheave setting and to determine the maximum continuous BHP.
3. kW = BHP x 0.838.

**ZF240 (20 Ton) Side Duct Metric**

Air Flow M <sup>3</sup> /sec.	Available External Static Pressure - Pa <sup>1</sup>																							
	100		149		199		249		299		349		399		448		498		548		598		648	
	RPM	kW	RPM	kW	RPM	kW	RPM	kW	RPM	kW	RPM	kW	RPM	kW	RPM	kW	RPM	kW	RPM	kW	RPM	kW	RPM	kW
	High Static 6.3 HP & Field Supplied Drive												High Static 6.3 HP & OEM Drive											
2.45	678	1.01	715	1.36	751	1.70	787	2.01	823	2.30	858	2.56	892	2.79	925	2.98	957	3.12	987	3.23	1015	3.29	1042	3.30
2.64	697	1.30	733	1.66	770	1.99	806	2.30	842	2.60	876	2.85	911	3.08	944	3.27	975	3.42	1005	3.52	1034	3.58	1060	3.59
2.83	717	1.62	754	1.98	790	2.31	826	2.62	862	2.91	897	3.17	931	3.39	964	3.59	996	3.74	1026	3.84	1054	3.90	1081	3.91
3.02	740	1.97	776	2.32	812	2.66	848	2.98	884	3.26	919	3.52	953	3.74	986	3.94	1018	4.09	1048	4.19	1076	4.25	1103	4.26
3.21	763	2.35	800	2.71	836	3.04	872	3.36	908	3.64	943	3.90	977	4.12	1010	4.32	1042	4.47	1072	4.57	1100	4.63	1127	4.64
3.40	789	2.77	825	3.12	861	3.45	898	3.77	933	4.06	968	4.32	1002	4.54	1035	4.73	1067	4.88	1097	4.99	1126	5.05	1152	5.06
3.59	815	3.21	852	3.57	888	3.91	924	4.22	960	4.50	995	4.77	1029	4.99	1062	5.18	1094	5.33	1124	5.44	1152	5.50	1179	5.50
3.78	844	3.70	880	4.06	916	4.39	952	4.71	988	5.00	1023	5.25	1057	5.47	1090	5.67	1122	5.82	1152	5.92	1180	5.98	1207	5.99
3.96	873	4.22	909	4.57	946	4.91	982	5.23	1018	5.51	1053	5.77	1087	6.00	1120	6.19	1151	6.34	1182	6.44	1210	6.50	-	-
4.15	904	4.77	940	5.13	977	5.47	1013	5.78	1048	6.07	1083	6.32	1117	6.55	-	-	-	-	-	-	-	-	-	-
4.34	936	5.36	972	5.70	1009	6.06	1045	6.37	1080	6.66	-	-	-	-	-	-	-	-	-	-	-	-	-	-
4.53	969	5.99	1005	6.34	1042	6.68	-	-	-	-	-	-	-	-	-	-	-	-	-	-	-	-	-	-
4.72	1003	6.64	-	-	-	-	-	-	-	-	-	-	-	-	-	-	-	-	-	-	-	-	-	-

Field Supplied Motor & Drive

1. Blower performance includes gas heat exchangers and 2" filters. See STATIC RESISTANCE table for additional applications.
2. See RPM SELECTION table to determine desired motor sheave setting and to determine the maximum continuous BHP.

## ZF180-240 Bottom Duct Application

### ZF180 (15 Ton) Bottom Duct Imperial

Air Flow (CFM)	Available External Static Pressure - IWG <sup>1</sup>																							
	0.4		0.6		0.8		1.0		1.2		1.4		1.6		1.8		2.0		2.2		2.4		2.6	
	RPM	BHP	RPM	BHP	RPM	BHP	RPM	BHP	RPM	BHP	RPM	BHP	RPM	BHP	RPM	BHP	RPM	BHP	RPM	BHP	RPM	BHP	RPM	BHP
	High Static 4.0 HP & Field Supplied Drive						High Static 4.0 HP & OEM Drive						Field Supplied Motor & Drive											
4400	803	1.70	841	2.00	877	2.28	919	2.52	991	2.84	1055	3.13	1110	3.38	1155	3.59	1193	3.78	1221	3.93	1242	4.04	1253	4.12
4800	832	2.11	870	2.42	906	2.69	948	2.93	1020	3.25	1084	3.54	1139	3.79	1185	4.01	1222	4.19	1250	4.34	1271	4.45	1282	4.53
5200	863	2.55	900	2.86	936	3.14	979	3.38	1051	3.70	1115	3.99	1169	4.24	1215	4.46	1253	4.64	1281	4.79	1301	4.90	1313	4.98
5600	896	3.03	933	3.34	969	3.62	1011	3.86	1084	4.19	1147	4.47	1202	4.73	1248	4.94	1285	5.13	1314	5.27	1334	5.39	1345	5.47
6000	930	3.54	967	3.86	1003	4.13	1045	4.38	1118	4.70	1181	4.99	1236	5.24	1282	5.46	-	-	-	-	-	-	-	-
6400	965	4.09	1002	4.41	1038	4.68	1081	4.93	1153	5.25	1217	5.54	-	-	-	-	-	-	-	-	-	-	-	-
6800	1002	4.67	1039	4.99	1075	5.27	1117	5.51	-	-	-	-	-	-	-	-	-	-	-	-	-	-	-	-
7200	1040	5.28	1077	5.60	-	-	-	-	-	-	-	-	-	-	-	-	-	-	-	-	-	-	-	-

1. Blower performance includes gas heat exchangers and 2" filters. See STATIC RESISTANCE table for additional applications.
2. See RPM SELECTION table to determine desired motor sheave setting and to determine the maximum continuous BHP.
3. kW = BHP x 0.838.

### ZF180 (15 Ton) Bottom Duct Metric

Air Flow M <sup>3</sup> /sec.	Available External Static Pressure - Pa <sup>1</sup>																							
	100		149		199		249		299		349		399		448		498		548		598		648	
	RPM	kW	RPM	kW	RPM	kW	RPM	kW	RPM	kW	RPM	kW	RPM	kW	RPM	kW	RPM	kW	RPM	kW	RPM	kW	RPM	kW
	High Static 4.0 HP & Field Supplied Drive						High Static 4.0 HP & OEM Drive						Field Supplied Motor & Drive											
2.08	803	1.27	841	1.49	877	1.70	919	1.88	991	2.12	1055	2.33	1110	2.52	1155	2.68	1193	2.82	1221	2.93	1242	3.01	1253	3.07
2.27	832	1.57	870	1.80	906	2.01	948	2.18	1020	2.42	1084	2.64	1139	2.83	1185	2.99	1222	3.12	1250	3.24	1271	3.32	1282	3.38
2.45	863	1.90	900	2.13	936	2.34	979	2.52	1051	2.76	1115	2.98	1169	3.16	1215	3.33	1253	3.46	1281	3.57	1301	3.65	1313	3.71
2.64	896	2.26	933	2.49	969	2.70	1011	2.88	1084	3.12	1147	3.33	1202	3.53	1248	3.68	1285	3.83	1314	3.93	1334	4.02	1345	4.08
2.83	930	2.64	967	2.88	1003	3.08	1045	3.27	1118	3.50	1181	3.72	1236	3.91	1282	4.07	-	-	-	-	-	-	-	-
3.02	965	3.05	1002	3.29	1038	3.49	1081	3.68	1153	3.91	1217	4.13	-	-	-	-	-	-	-	-	-	-	-	-
3.21	1002	3.48	1039	3.72	1075	3.93	1117	4.11	-	-	-	-	-	-	-	-	-	-	-	-	-	-	-	-
3.40	1040	3.94	1077	4.18	-	-	-	-	-	-	-	-	-	-	-	-	-	-	-	-	-	-	-	-

1. Blower performance includes gas heat exchangers and 2" filters. See STATIC RESISTANCE table for additional applications.
2. See RPM SELECTION table to determine desired motor sheave setting and to determine the maximum continuous BHP.

**ZF240 (20 Ton) Bottom Duct Imperial**

Air Flow (CFM)	Available External Static Pressure - IWG <sup>1</sup>																									
	0.4		0.6		0.8		1.0		1.2		1.4		1.6		1.8		2.0		2.2		2.4		2.6			
	RPM	BHP	RPM	BHP	RPM	BHP	RPM	BHP	RPM	BHP	RPM	BHP	RPM	BHP	RPM	BHP	RPM	BHP	RPM	BHP	RPM	BHP	RPM	BHP	RPM	BHP
	High Static 6.3 HP & Field Supplied Drive												High Static 6.3 HP & OEM Drive													
5200	711	1.47	747	1.92	782	2.34	818	2.73	853	3.09	887	3.42	921	3.70	953	3.94	985	4.13	1014	4.26	1042	4.34	1068	4.35		
5600	732	1.89	768	2.33	803	2.76	839	3.15	874	3.51	908	3.84	942	4.12	974	4.36	1005	4.54	1035	4.68	1063	4.75	1089	4.76		
6000	754	2.35	790	2.79	826	3.21	862	3.61	897	3.97	931	4.29	965	4.58	997	4.81	1028	5.00	1058	5.14	1086	5.21	1112	5.22		
6400	779	2.85	814	3.29	850	3.71	886	4.11	921	4.47	955	4.79	989	5.08	1021	5.31	1052	5.50	1082	5.64	1110	5.71	1136	5.72		
6800	804	3.39	840	3.84	876	4.26	912	4.65	947	5.01	981	5.34	1015	5.62	1047	5.86	1078	6.05	1108	6.18	1136	6.26	1162	6.27		
7200	832	3.98	868	4.43	903	4.85	939	5.24	974	5.60	1008	5.93	1042	6.21	1074	6.45	1105	6.64	1135	6.77	1163	6.85	1189	6.86		
7600	860	4.62	896	5.06	932	5.49	967	5.88	1002	6.24	1037	6.56	1070	6.85	1103	7.09	1134	7.27	1164	7.41	1192	7.48	-	-		
8000	890	5.30	926	5.74	962	6.17	997	6.56	1032	6.92	1067	7.24	1100	7.53	1133	7.77	1164	7.95	1194	8.09	-	-	-	-		
8400	921	6.02	957	6.47	993	6.89	1028	7.28	1064	7.64	1098	7.97	1131	8.25	1164	8.49	1195	8.68	-	-	-	-	-	-		
8800	954	6.79	989	7.24	1025	7.66	1061	8.05	1096	8.41	1130	8.74	-	-	-	-	-	-	-	-	-	-	-	-		
9200	987	7.60	1023	8.05	1059	8.47	1094	8.86	-	-	-	-	-	-	-	-	-	-	-	-	-	-	-	-		
9600	1021	8.45	1057	8.90	-	-	-	-	-	-	-	-	-	-	-	-	-	-	-	-	-	-	-	-		
10000	546	4.89	564	5.11	-	-	-	-	-	-	-	-	-	-	-	-	-	-	-	-	-	-	-	-		

Field Supplied Motor & Drive

1. Blower performance includes gas heat exchangers and 2" filters. See STATIC RESISTANCE table for additional applications.
2. See RPM SELECTION table to determine desired motor sheave setting and to determine the maximum continuous BHP.
3. kW = BHP x 0.838.

**ZF240 (20 Ton) Bottom Duct Metric**

Air Flow M <sup>3</sup> /sec.	Available External Static Pressure - Pa <sup>1</sup>																									
	100		149		199		249		299		349		399		448		498		548		598		648			
	RPM	kW	RPM	kW	RPM	kW	RPM	kW	RPM	kW	RPM	kW	RPM	kW	RPM	kW	RPM	kW	RPM	kW	RPM	kW	RPM	kW	RPM	kW
	High Static 6.3 HP & Field Supplied Drive												High Static 6.3 HP & OEM Drive													
2.45	711	1.10	747	1.43	782	1.75	818	2.04	853	2.30	887	2.55	921	2.76	953	2.94	985	3.08	1014	3.18	1042	3.24	1068	3.24		
2.64	732	1.41	768	1.74	803	2.06	839	2.35	874	2.62	908	2.86	942	3.07	974	3.25	1005	3.39	1035	3.49	1063	3.54	1089	3.55		
2.83	754	1.75	790	2.08	826	2.39	862	2.69	897	2.82	931	3.20	965	3.42	997	3.59	1028	3.72	1058	3.83	1086	3.89	1112	3.89		
3.02	779	2.13	814	2.45	850	2.77	886	3.07	921	3.33	955	3.57	989	3.79	1021	3.96	1052	4.10	1082	4.21	1110	4.26	1136	4.27		
3.21	804	2.53	840	2.86	876	3.18	912	3.47	947	3.74	981	3.98	1015	4.19	1047	4.37	1078	4.51	1108	4.61	1136	4.67	1162	4.68		
3.40	832	2.97	868	3.30	903	3.62	939	3.91	974	4.18	1008	4.42	1042	4.63	1074	4.81	1105	4.95	1135	5.05	1163	5.11	1189	5.12		
3.59	860	3.45	896	3.77	932	4.09	967	4.39	1002	4.65	1037	4.89	1070	5.11	1103	5.29	1134	5.42	1164	5.53	1192	5.58	-	-		
3.78	890	3.95	926	4.28	962	4.6	997	4.89	1032	5.16	1067	5.40	1100	5.62	1133	5.79	1164	5.93	1194	6.03	-	-	-	-		
3.96	921	4.49	957	4.82	993	5.14	1028	5.43	1064	5.70	1098	5.94	1131	6.15	1164	6.33	1195	6.47	-	-	-	-	-	-		
4.15	954	5.06	989	5.40	1025	5.71	1061	6.00	1096	6.27	1130	6.52	-	-	-	-	-	-	-	-	-	-	-	-		
4.34	987	5.67	1023	6.00	1059	6.32	1094	6.61	-	-	-	-	-	-	-	-	-	-	-	-	-	-	-	-		
4.53	1021	6.30	1057	6.64	-	-	-	-	-	-	-	-	-	-	-	-	-	-	-	-	-	-	-	-		

Field Supplied Motor & Drive

1. Blower performance includes gas heat exchangers and 2" filters. See STATIC RESISTANCE table for additional applications.
2. See RPM SELECTION table to determine desired motor sheave setting and to determine the maximum continuous BHP.
3. kW = BHP x 0.838.

## RPM Selection

Size (Tons)	Model	HP	Max BHP	Motor Sheave	Blower Sheave	6 Turns Open	5 Turns Open	4 Turns Open	3 Turns Open	2 Turns Open	1 Turn Open	Fully Closed
180 (15)	ZF	4.0	4.72	1VP62	BK75	925	967	1009	1051	1093	1135	N/A
240 (20)	ZF	6.3	7.13	1VP75	BK100	895	926	956	987	1018	1049	N/A

\* Maximum blower speed is 1400 RPM for ZF180 and 1200 RPM for ZF240

## Additional Static Resistance

Size (Tons)	Model	CFM	Cooling Only <sup>1</sup>	Economizer <sup>2 3</sup>	Electric Heat kW <sup>2</sup>			
					18	36	54	72
180 (15)	ZF	4500	0.10	0.10	0.10	0.10	0.20	0.20
		6000	0.10	0.10	0.10	0.20	0.30	0.40
		7500	0.10	0.10	0.10	0.30	0.40	0.60
240 (20)	ZF	6000	0.10	0.10	0.10	0.10	0.20	0.20
		7500	0.10	0.10	0.10	0.20	0.30	0.40
		9000	0.15	0.15	0.10	0.30	0.40	0.60
		10500	0.15	0.15	0.20	0.40	0.60	0.80
		12000	0.20	0.20	0.30	0.50	0.70	0.90

1. Add these values to the available static resistance in the respective Blower Performance Tables.
2. Deduct these values from the available external static pressure shown in the respective Blower Performance Tables.
3. The pressure drop through the economizer is greater for 100% outdoor air than for 100% return air. If the resistance of the return air duct is less than 0.25 IWG, the unit will deliver less CFM during full economizer operation.

**Drive Selection**

1. Determine side or bottom supply duct application.
2. Determine desired airflow
3. Calculate or measure the amount of external static pressure.
4. Using the operating point determined from steps 1, 2 & 3, locate this point on the appropriate supply air blower performance table. (Linear interpolation may be necessary.)
5. Noting the RPM and BHP from step 4, locate the appropriate motor and/or drive on the RPM selection table.
6. Review the BHP compared to the motor options available. Select the appropriate motor and/or drive.
7. Review the RPM range for the motor options available. Select the appropriate drive if multiple drives are available for the chosen motor.
8. Determine turns open to obtain the desired operation point.

**Example**

1. 6800 CFM
2. 2.0 iwg
3. Using the supply air blower performance table below, the following data point was located: 1020 RPM & 5.92 BHP.
4. Using the RPM selection table below, Size X and Model Y is found.
5. 5.92 BHP exceeds the maximum continuous BHP rating of the 5.0 HP motor. The 7.5 HP motor is required.
6. 1020 RPM is within the range of the 7.5 HP drives.
7. Using the 7.5 HP motor and drive, 3.5 turns open will achieve 1020 RPM.

**Example Supply Air Blower Performance**

Air Flow (CFM)	Available External Static Pressure - IWG																									
	0.4		0.6		0.8		1.0		1.2		1.4		1.6		1.8		2.0		2.2		2.4		2.6			
	RPM	BHP	RPM	BHP	RPM	BHP	RPM	BHP	RPM	BHP	RPM	BHP	RPM	BHP	RPM	BHP	RPM	BHP	RPM	BHP	RPM	BHP	RPM	BHP	RPM	BHP
	Standard 5 HP & Drive												High Static 7.5 HP & Drive													
6400	719	2.55	756	3.03	792	3.49	828	3.92	864	4.32	899	4.67	933	4.98	966	5.24	998	5.45	1028	5.59	1056	5.67	1083	5.68	1103	5.68
6800	742	3.02	778	3.51	814	3.97	850	4.40	886	4.79	921	5.15	955	5.46	988	5.72	1020	5.92	1050	6.07	1078	6.15	1105	6.16	1129	6.16
7200	765	3.54	802	4.03	838	4.49	874	4.92	910	5.32	945	5.67	979	5.98	1012	6.24	1044	6.44	1074	6.59	1102	6.67	1129	6.68	1154	6.68
7600	790	4.11	827	4.60	863	5.06	899	5.49	935	5.88	970	6.24	1004	6.55	1037	6.81	1069	7.01	1099	7.16	1127	7.24	1154	7.25	1179	7.25
													7.5 HP & Field Supplied Drive													

**Table X: RPM Selection**

Size (Tons)	Model	HP	Max BHP	Motor Sheave	Blower Sheave	6 Turns Open	5 Turns Open	4 Turns Open	3 Turns Open	2 Turns Open	1 Turn Open	Fully Closed
X	Y	5	5.75	1VP60	BK110	730	765	800	835	870	905	N/A
		7.5	8.63	1VP60	BK090	905	950	990	1035	1075	1120	N/A

**Altitude/Temperature Correction Factors Imperial**

Air Temp. °F	Altitude (Ft.)										
	0	1000	2000	3000	4000	5000	6000	7000	8000	9000	10000
40	1.060	1.022	0.986	0.950	0.916	0.882	0.849	0.818	0.788	0.758	0.729
50	1.039	1.002	0.966	0.931	0.898	0.864	0.832	0.802	0.772	0.743	0.715
60	1.019	0.982	0.948	0.913	0.880	0.848	0.816	0.787	0.757	0.729	0.701
70	1.000	0.964	0.930	0.896	0.864	0.832	0.801	0.772	0.743	0.715	0.688
80	0.982	0.947	0.913	0.880	0.848	0.817	0.787	0.758	0.730	0.702	0.676
90	0.964	0.929	0.897	0.864	0.833	0.802	0.772	0.744	0.716	0.689	0.663
100	0.946	0.912	0.880	0.848	0.817	0.787	0.758	0.730	0.703	0.676	0.651

**Altitude/Temperature Correction Factors Metric**

Air Temp. °C	Altitude (Meter)										
	0	305	610	914	1219	1524	1829	2134	2438	2743	3048
4.4	1.060	1.022	0.986	0.950	0.916	0.882	0.849	0.818	0.788	0.758	0.729
10.0	1.039	1.002	0.966	0.931	0.898	0.864	0.832	0.802	0.772	0.743	0.715
15.5	1.019	0.982	0.948	0.913	0.880	0.848	0.816	0.787	0.757	0.729	0.701
21.0	1.000	0.964	0.930	0.896	0.864	0.832	0.801	0.772	0.743	0.715	0.688
26.6	0.982	0.947	0.913	0.880	0.848	0.817	0.787	0.758	0.730	0.702	0.676
32.0	0.964	0.929	0.897	0.864	0.833	0.802	0.772	0.744	0.716	0.689	0.663
38.0	0.946	0.912	0.880	0.848	0.817	0.787	0.758	0.730	0.703	0.676	0.651

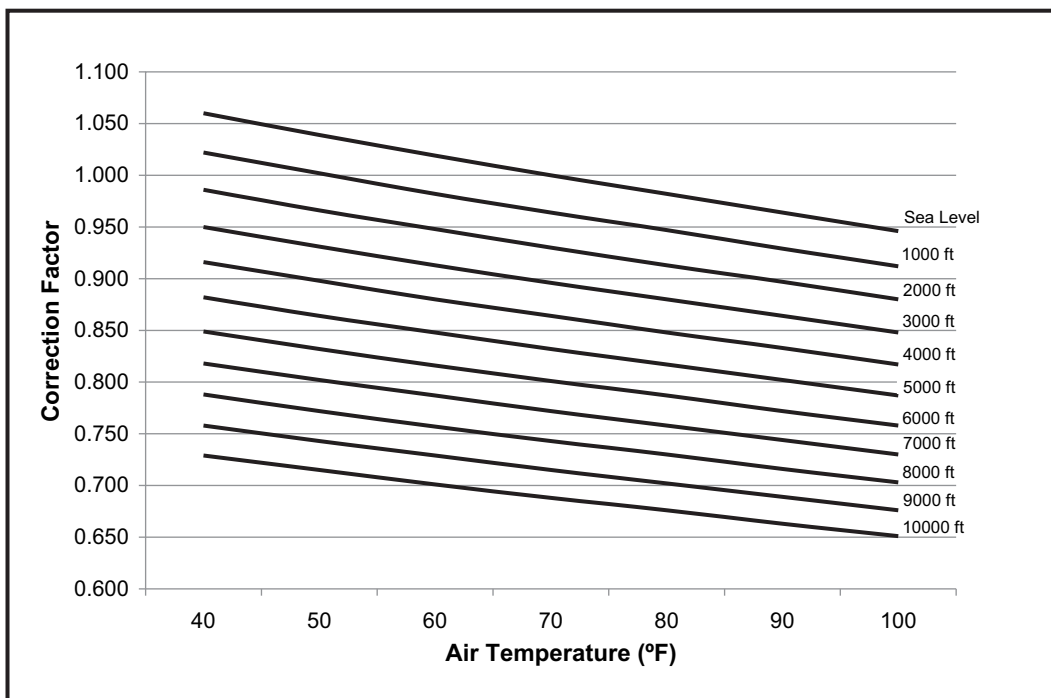

**Altitude/Temperature Correction Factors Imperial**

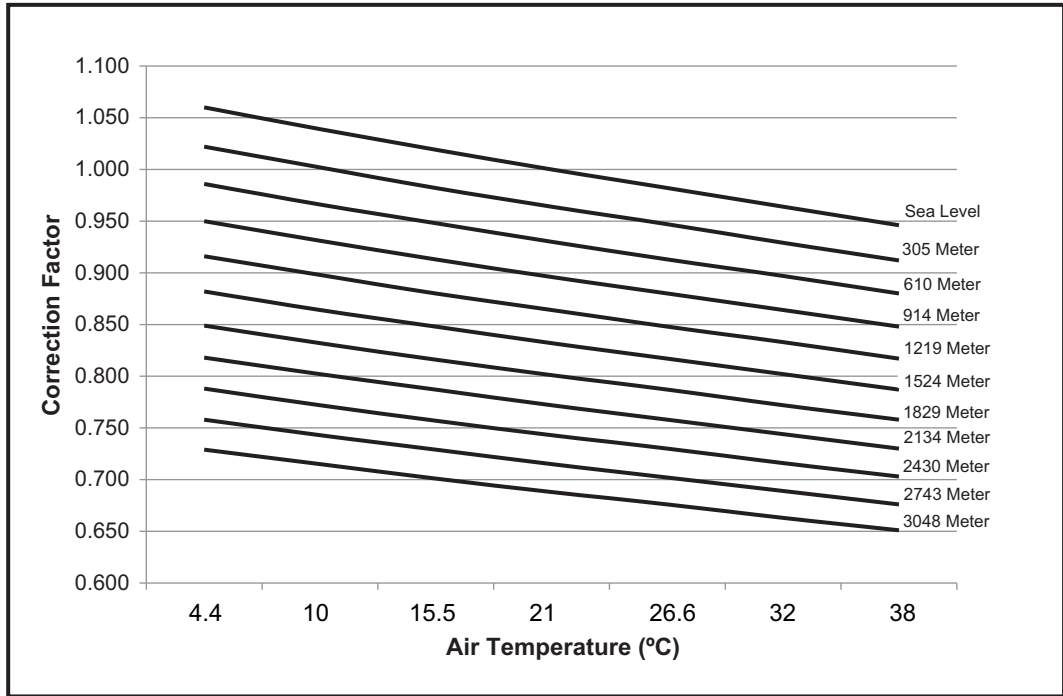

**Altitude/Temperature Correction Factors Metric**

**Gas Heat Minimum Supply Air Imperial**

Size (Tons)	Heat Size	Supply Air (CFM)			
		Cooling		Heating	
		Min	Max	Min	Max
180 (15)	24	4500	7000	4500	7000
	32	4500	7000	4500	7000
240 (20)	24	6000	9400	6000	9400
	32	6000	9400	6000	9400

**Gas Heat Minimum Supply Air Metric**

Size (Tons)	Heat Size	Supply Air (M <sup>3</sup> /S)			
		Cooling		Heating	
		Min	Max	Min	Max
180 (15)	24	2.13	3.3	2.13	3.3
	32	2.13	3.3	2.13	3.3
240 (20)	24	2.83	4.44	2.83	4.44
	32	2.83	4.44	2.83	4.44

**Electric Heat Minimum Supply Air Imperial**

Size (Tons)	Voltage	Minimum Supply Air (CFM)			
		Heater kW			
		18	36	54	72
180 (15)	380/415-3-50	4500	4500	5000	5000
240 (20)	380/415-3-50	6000	6000	6000	6000

**Electric Heat Minimum Supply Air Metric**

Size (Tons)	Voltage	Minimum Supply Air (M <sup>3</sup> /S)			
		Heater kW			
		18	36	54	72
180 (15)	380/415-3-50	2.12	2.12	2.36	2.36
240 (20)	380/415-3-50	2.83	2.83	2.83	2.83

## Indoor Blower Specifications

Size (Tons)	Model	Motor					Motor Sheave			Blower Sheave			Belt
		HP	RPM	Eff.	SF	Frame	Datum Dia. (in.)	Bore (in.)	Model	Datum Dia. (in.)	Bore (in.)	Model	
180 (15)	ZF	4.0	1450	0.89	1.15	184T	4.4 - 5.4	1 1/8	1VP62	6.9	1	BK75	BX68
240 (20)	ZF	6.3	1450	0.91	1.15	213T	5.8 - 6.8	1 3/8	1VP75	9.4	1 3/16	BK100	BX81

## Power Exhaust Specifications

Voltage	Motor			Motor			CFM @ 0.2 ESP
	HP	RPM <sup>1</sup>	QTY	LRA	FLA	MCA	
460-1-60	3/4	1075	1	4.1	2.2	2.75	5250

1. Motors are multi-tapped and factory wired for high speed.

## Electric Heat Multipliers

Voltage		kW Capacity Multipliers <sup>1</sup>
Nominal	Applied	
480	415	0.75
480	380	0.63

1. Electric heaters are rated at nominal voltage. Use this table to determine the electric heat capacity for heaters applied at lower voltages.

## Sound Performance

### ZF Indoor Sound Power Levels

Size (Tons)	CFM	ESP (IWG)	Blower		Sound Power, dB (10 <sup>-12</sup> ) Watts								
					Sound Rating <sup>1</sup> dB (A)	Octave Band Centerline Frequency (Hz)							
			RPM	BHP		63	125	250	500	1000	2000	4000	8000
180 (15)	6000	1.0	1,080	4.6	91	88	90	90	87	85	81	81	76
240 (20)	8000	1.0	1,020	6.6	86	85	85	83	82	82	78	75	70

1. These values have been accessed using a model of sound propagation from a point source into the hemispheric/free field. The dBA values provided are to be used for reference only. Calculation of dBA values cover matters of system design and the fan manufacturer has no way of knowing the details of each system. This constitutes an exception to any specification or guarantee requiring a dBA value of sound data in any other form than sound power level ratings.

### ZF Outdoor Sound Power Levels

Size (Tons)	Sound Rating <sup>1</sup> dB (A)	Sound Power, dB (10 <sup>-12</sup> ) Watts							
		Octave Band Centerline Frequency (Hz)							
		63	125	250	500	1000	2000	4000	8000
180 (15)	92	90	93	91	89	86	83	80	75
240 (20)	92	91	94	92	89	87	83	81	76

1. Rated in accordance with AHRI 270 standard.

## Electrical Data

### ZF180 - 240

#### ZF180-240 - High Static Drive

Size (Tons)	Volt	Compressors (each)						OD Fan Motors (each)	Supply Blower Motor	Electric Heat Option				MCA <sup>1</sup> (Amps)	Max Fuse <sup>2</sup> / Breaker <sup>3</sup> Size (Amps)		
		RLA		LRA		MCC				FLA	FLA	Model	kW			Stages	Amps
		C1	C2	C1	C2	C1	C2										
180 (15)	380-3-50	18.6	14.5	100.0	90.5	26.0	20.3	2.1	6.3	None	--	--	--	49	60		
										E18	11.3	1	17.1	49	60		
										E36	22.6	2	34.3	51	60		
										E54	33.8	2	51.4	73	80		
										E72	45.1	2	68.6	90	100		
	415-3-50	18.6	14.5	111.0	101.0	26.0	20.3	2.1	6.7	None	--	--	--	49	60		
										E18	13.5	1	18.7	49	60		
										E36	26.9	2	37.4	56	60		
										E54	40.0	2	56.2	79	80		
										E72	53.8	2	74.9	84	90		
240 (20)	380-3-50	20.7	20.0	110.0	110.0	29.0	28.0	2.1	8.2	None	--	--	--	60	70		
										E18	11.3	1	17.1	60	70		
										E36	22.6	2	34.3	60	70		
										E54	33.8	2	51.4	75	80		
										E72	45.1	2	68.6	96	100		
	415-3-50	20.7	20.0	118.0	118.0	29.0	28.0	2.1	9.1	None	--	--	--	60	70		
										E18	13.5	1	18.7	60	70		
										E36	26.9	2	37.4	60	70		
										E54	40.0	2	56.2	82	80		
										E72	53.8	2	74.9	87	90		

1. Minimum Circuit Ampacity.
2. Dual Element, Time Delay Type.
3. HACR type per NEC.

## ZF180-240 Wiring Diagrams

## ZF180-240 Typical Control Diagram

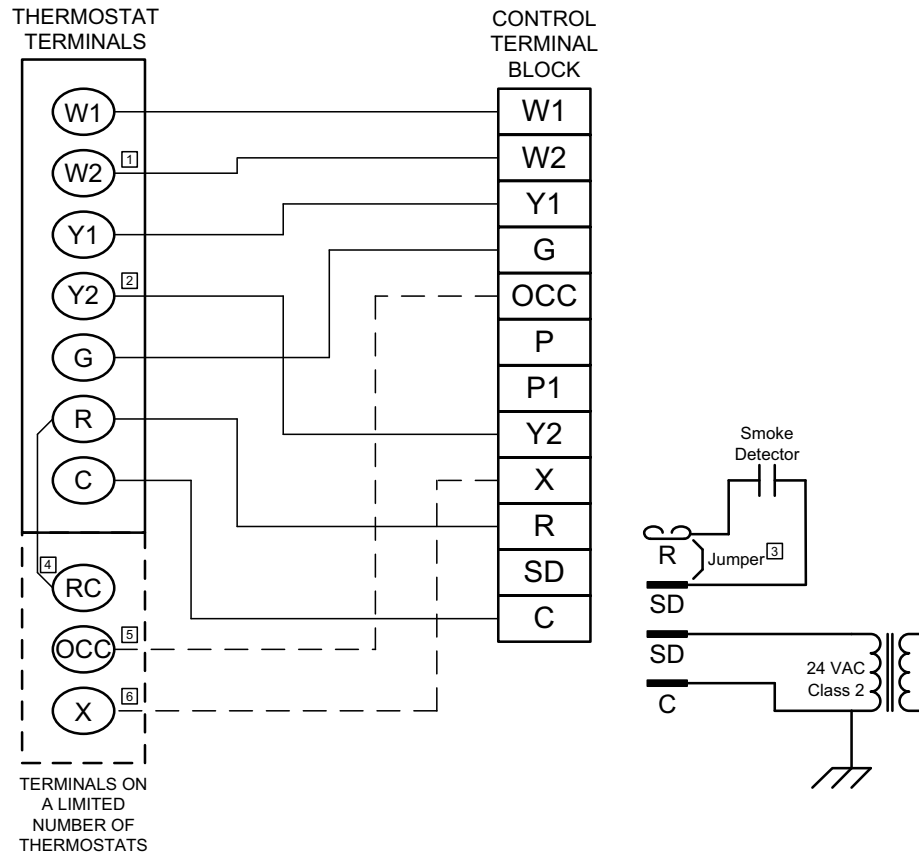

- <sup>1</sup> Second stage heating not required on single stage heating units.
- <sup>2</sup> Second stage cooling not required on single stage cooling units.
- <sup>3</sup> Jumper is required if there is no Smoke Detector circuit.
- <sup>4</sup> Jumper is required for any combination of R, RC, or RH.
- <sup>5</sup> OCC is an output from the thermostat to indicate the Occupied condition.
- <sup>6</sup> X is an input to the thermostat to display Error Status conditions.

## Weights and Dimensions

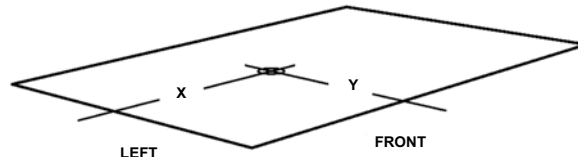

### ZF Unit 4 Point Load Weight

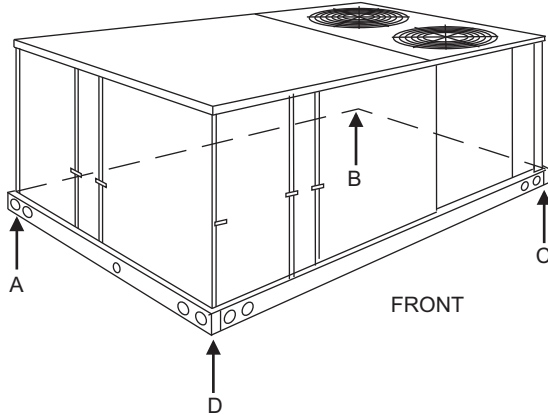

### ZF Unit 6 Point Load Weight

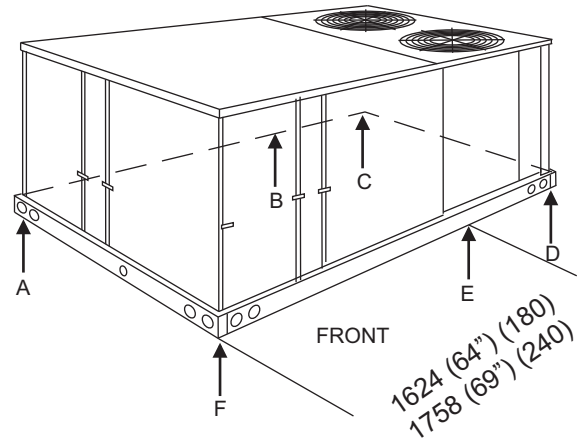

### ZF180-240 Unit Weights Imperial

Size (Tons)	Model	Weight (lbs.)		Center of Gravity		4 Point Load Location (lbs.)				6 Point Load Location (lbs.)					
		Shipping	Operating	X	Y	A	B	C	D	A	B	C	D	E	F
180 (15)	ZF	1685	1680	66.5	45.7	391	443	449	397	256	277	302	306	281	259
240 (20)	ZF	2405	2400	70	44	558	590	643	609	369	382	397	433	417	402

### ZF180-240 Unit Weights Metric

Size (Tons)	Model	Weight (kg.)		Center of Gravity (mm)		4 point Load Location (kg.)				6 point Load Location (kg.)					
		Shipping	Operating	X	Y	A	B	C	D	A	B	C	D	E	F
180 (15)	ZF	766	764	1689	1161	178	202	204	180	116	126	137	139	128	118
240 (20)	ZF	1093	1091	1778	1118	254	268	292	277	168	174	180	197	189	183

### ZF180-240 Unit Accessory Weights Imperial

Unit Accessory	Weight (lbs.)	
	Shipping	Operating
Economizer	165	160
Power Exhaust	90	85
Electric Heat <sup>1</sup>	40	40
Gas Heat <sup>2</sup>	240	240
Motorized Damper	150	150
Barometric Damper	50	45
Econ./Motorized Damper Rain Hood	60	55
Econ./Power Exhaust Rain Hood	95	90
Wood Skid	220	220
Roof Curb	190	185

### ZF180-240 Unit Accessory Weights Metric

Unit Accessory	Weight (kg.)	
	Shipping	Operating
Economizer	74.8	72.6
Power Exhaust	40.8	40.8
Electric Heat <sup>1</sup>	18.1	18.1
Gas Heat <sup>2</sup>	108.9	108.9
Motorized Damper	68	68
Barometric Damper	22.7	22.7
Econ./Motorized Damper Rain Hood	27.2	27.2
Econ./Power Exhaust Rain Hood	43.1	43.1
Wood Skid	99.8	99.8
Roof Curb	86.2	86.2

1. Weight given is for the maximum heater size available (54KW).
2. Weight given is for the maximum number of tube heat exchangers available (8 tube).

1. Weight given is for the maximum heater size available (54KW).
2. Weight given is for the maximum number of tube heat exchangers available (8 tube).

## Unit Dimensions

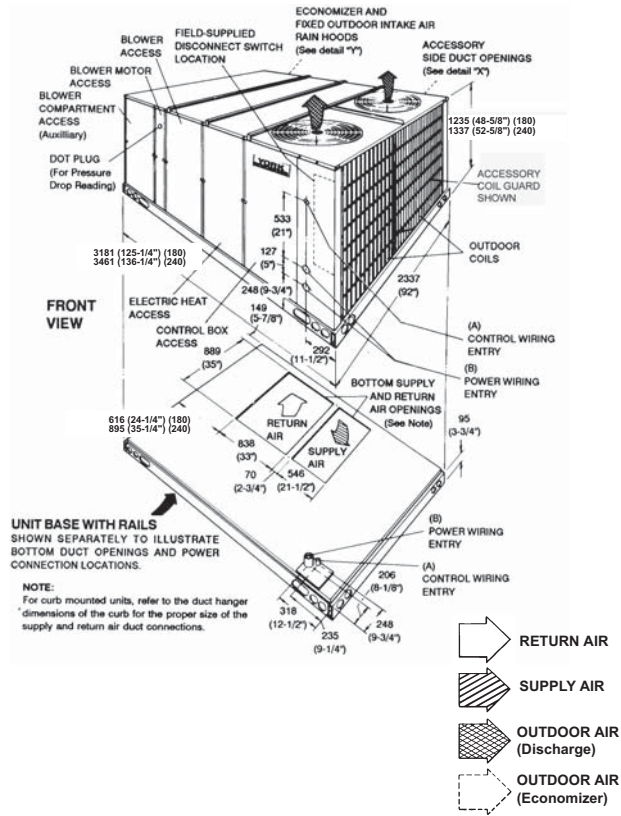

### Unit Dimensions - ZF Cool & Cool/electric Heat

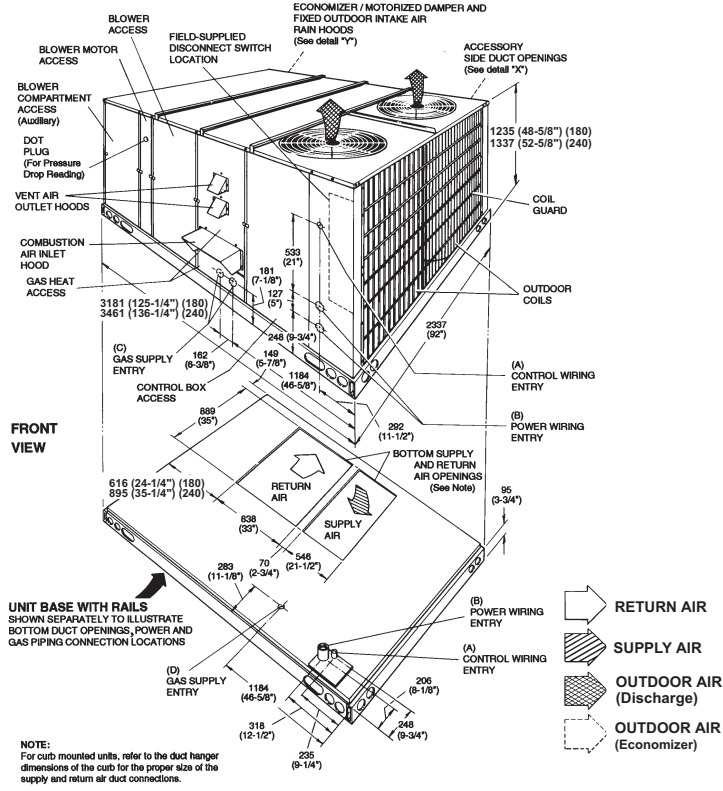

Unit Dimensions - ZF Gas Heat

**Utilities Entry Data**

HOLE	OPENING SIZE (DIA.) (MM/IN.)	USED FOR	
A	29/1-1/8" KO	Control Wiring	Side
	19/3/4" NPS (Fem.)		Bottom
B	92/3-5/8" KO	Power Wiring	Side
	76/3" NPS (Fem.)		Bottom
C	60/2-3/8" KO	Gas Piping (Front) <sup>1</sup>	
D	43/1-11/16" Hole	Gas Piping (Bottom) <sup>1, 2</sup>	

1. One-inch gas piping NPT required.
2. Opening in the bottom of the unit can be located by the slice in the insulation.

NOTE: All entry holes should be field sealed to prevent rain water entry into the building.

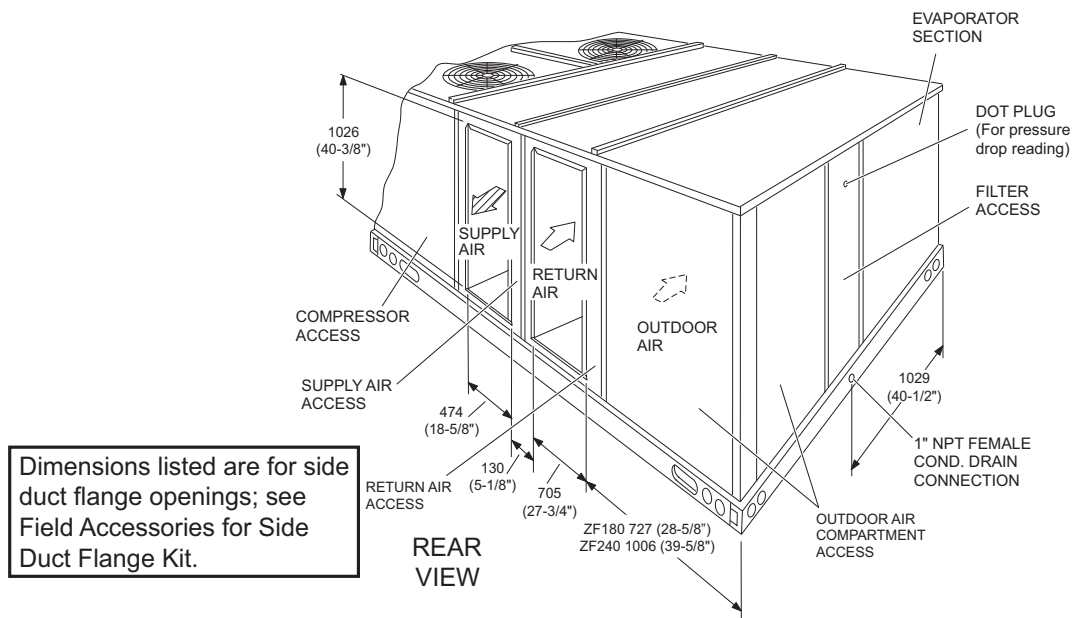

**Rear View Dimensions**

NOTE: Units are shipped with the bottom duct openings covered. An accessory flange kit is available for connecting side ducts.

**For bottom duct applications:**

1. Remove the side panels from the supply and return air compartments to gain access to the bottom supply and return air duct covers.
2. Remove and discard the bottom duct covers. Duct openings are closed with sheet metal covers except when the unit includes a power exhaust option. The covering consists of a heavy black paper composition.
3. Replace the side supply and return air compartment panels.

**For side duct applications:**

1. Replace the side panels on the supply and return air compartments with the side duct flange accessory kit panels.
2. Connect ductwork to the flanges on those panels.

**Minimum Clearances (MM/IN.)**

LOCATION	CLEARANCE
Front	914/36"
Rear	610/24" (Less Economizer) 1245/49" (With Economizer)
Left Side (Filter Access)	610/24" (Less Economizer) 914/36" (With Economizer) <sup>3</sup>
Right Side (Cond. Coil)	914/36"
Below Unit <sup>1</sup>	0/0"
Above Unit <sup>2</sup>	1829/72" With 914/36" Maximum Horizontal Overhang (For Condenser Air Discharge)

1. Units may be installed on combustible floors made from wood or class A, B, or C roof covering material.
2. Units must be installed outdoors. Overhanging structures or shrubs should not obstruct condenser air discharge outlet.
3. If economizer is factory installed, the unassembled rain hood must be removed from its ride along position in front of evaporator coil, or in the outdoor air compartment, prior to final installation.

**NOTE: ELEC / ELEC Models:** Units and ductwork are approved for zero clearance to combustible material when equipped with electric heaters.

**GAS / ELEC Models:** A 25mm/1" clearance must be provided between any combustible material and the supply air ductwork for a distance of .9 meter/3 feet from the unit.

The products of combustion must not be allowed to accumulate within a confined space and recirculate.

Locate unit so that the vent air outlet hood is at least:

- .9 meters/3 feet above any force air inlet located within 3.0 meters/10 horizontal feet (excluding those integral to the unit).
- 1.2 meters/4 feet below, four horizontal feet from, or one foot above any door or gravity air inlet into the building.
- 1.2 meters/4 feet from electric and gas meters, regulators and relief equipment.

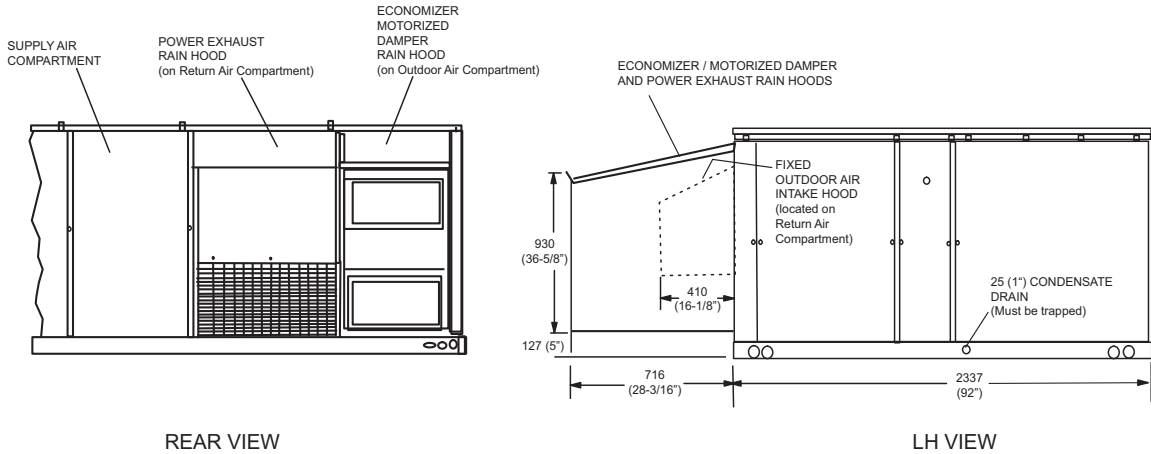

**Unit Clearances And Rainhood Dimensions (15 & 20 Ton)**

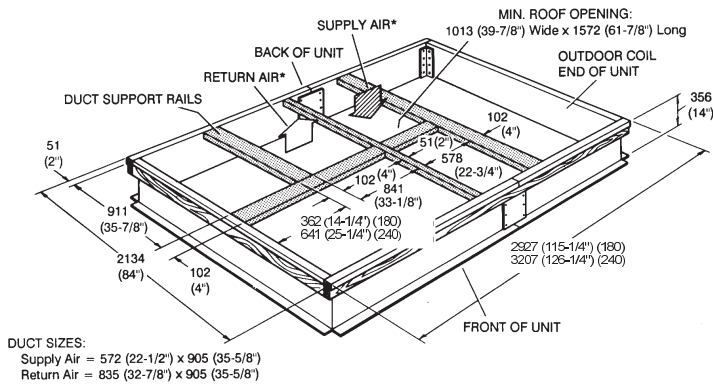

\* Supply and Return air (including duct support rails) as shown, are typical for Downflow duct applications

For location of Sideflow duct applications (on back of unit), refer to Unit Dimension details.

**Roof Curb Dimensions (All Models)**

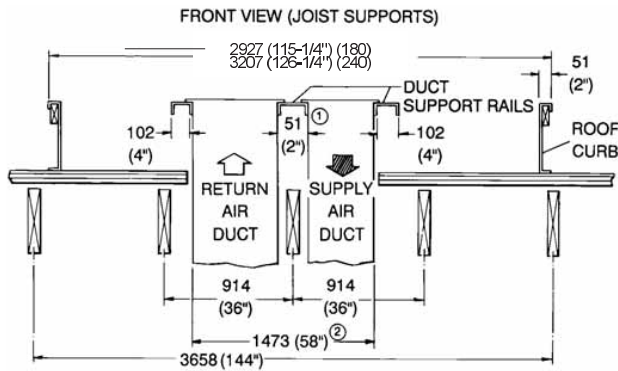

- ① The 51 (2") space between the duct allows for "jumping" an existing roof joist.
- ② The 1486 (58-1/2") overall dimension of the ducts allows ductwork penetration between roof joists that are spaced on 1829 (72") centers.

NOTE: Ducts can be installed onto the curb from the roof. All electrical connections can be made inside the curb.

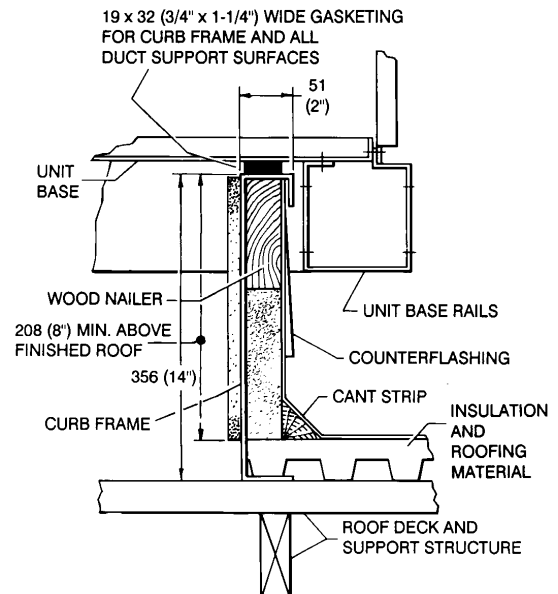

**Roof Curb Benefits**

**Unit Curb And Applications**

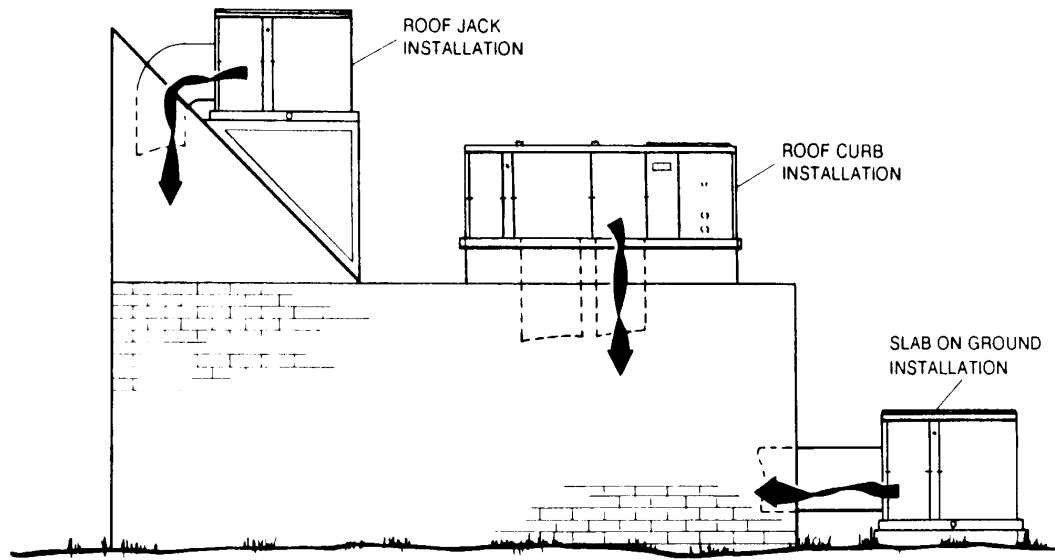

Typical Application

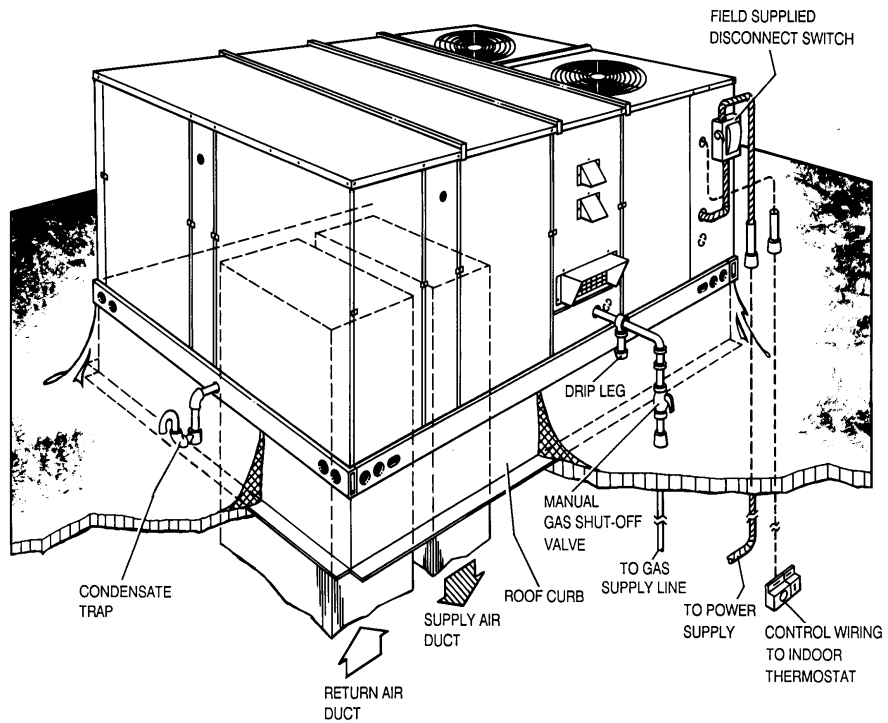

Typical Roof-top Installation (Gas/electric Unit Shown)

Subject to change without notice. Printed in U.S.A.  
 Copyright © 2014 by Johnson Controls, Inc. All rights reserved.

1056292-XTG-A-0613  
 Supersedes: Nothing

York International Corporation  
 5005 York Drive  
 Norman, OK 73069