



Thank you for choosing our toys! Please read through this instruction manual before use as it contains all the information you need to know about how to correctly, joyfully use this product.

**! PRECAUTIONS:**

**• Electric Product**

Do not give this product to children aged 8 or below. Like other electric products, this product is also to be used in a safe way to avoid electric shock.

**• Adult's Supervision Required**

Warning! Do not try to modify this product, which may void your right to use it.

**CHARGING**

- (1) The new Ni-Cd battery pack included in this set needs to be charged before use.
- (2) Plug the charger to a wall outlet and join the battery's connector and the charger's connector.
- (3) Please charge for at least 8 hours for the first 2 times. Then, it's enough to charge for 5-6 hours during normal use. Do not overcharge as it will not fill the battery with more power.
- (4) Please check on a regular basis the wire, plug and other electric parts on the toy, batteries and charger. If any damage is found, please repair it before use.

**TRANSMITTER & TRIMMER**

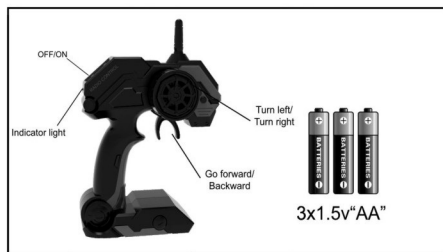

**INSTALLATION OF BATTERIES & ANTENNA**

- (1) Replace the battery cover.
- (2) Locate the hole on the top of the transmitter for installing the antenna. Insert the antenna in and turn clockwise to fix it.
- (3) Correctly install the rechargeable battery pack in the battery compartment and replace the battery cover.
- (4) Fasten the screw with a plus driver.

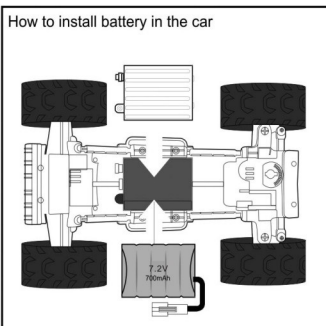

The car must charge with the special charger, be sure that the technology parameter is fit for the charger. Do not help yourselves to match a charger.

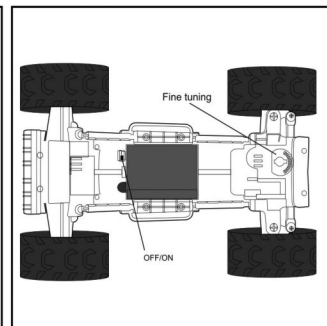

**BASIC OPERATIONS**

- (1) Turn on the car and set the band selectors on the transmitter and the chassis to the same position.
- (2) Use the 2 control levers on the transmitter to control the car to run forward/backward or to turn left/right.
- (3) If the car can't run along a straight line, please use the trimmer on the chassis for adjustment.
- (4) Remember to turn off the car and the transmitter after use.

**BATTERY SAFETY**

- 1) Adult's supervision is required for charging.
- (2) To charge the rechargeable battery pack in the car, first remove it from the chassis.
- (3) Timely remove exhausted batteries from the car and the transmitter.
- (4) Make sure the main switch is set to OFF before installing the battery pack into the car body.
- (5) Note polarity marks in the battery compartments when installing the batteries.
- (6) Do not try to charge non-rechargeable batteries.
- (7) Do not short-circuit the batteries.
- (8) If you plan to stop use for a long time, remove the batteries from the transmitter and the car body to avoid leakage.
- (9) Never throw the batteries into fire to avoid explosion or leakage.
- (10) Do not mix batteries from different producers or new and old batteries.
- (11) Use only recommended batteries or equivalent ones.
- (12) Check the batteries on a regular basis to avoid leakage.
- (13) Keep this manual well for future reference as it contains important information about this product.

**CARE & MAINTENANCE**

- (1) If you plan to stop use for a long time, remember to remove all the batteries.
- (2) If necessary, use a wet towel to gently wipe the car body clean.
- (3) Do not expose this toy to high temperature, high humidity or direct sunlight.
- (4) Do not put this toy in water to avoid damaging its electronic components.

**USE CAUTIONS**

When the car is in motion, do not touch the wheels by hand to avoid damages to the car.



When there's more than one car played in the same place, set the cars to different bands to avoid mutual interference.

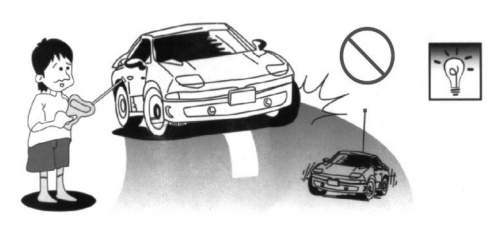

Do not play by the roads or in any other dangerous places to avoid accidents.

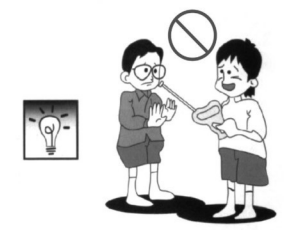

Do not bend the antenna or point it at other people or articles to avoid hurts.



Do not play in a place with puddle, mud or sand.

changes or modifications not expressly approved by the party responsible for compliance could void the user's authority to operate the equipment.

This equipment has been tested and found to comply with the limits for a Class B digital device, pursuant to Part 15 of the FCC Rules. These limits are designed to provide reasonable protection against harmful interference in a residential installation. This equipment generates, uses and can radiate radio frequency energy and, if not installed and used in accordance with the instructions, may cause harmful interference to radio communications. However, there is no guarantee that interference will not occur in a particular installation.

If this equipment does cause harmful interference to radio or television reception, which can be determined by turning the equipment off and on, the user is encouraged to try to correct the interference by one or more of the following measures:

- Reorient or relocate the receiving antenna.
- Increase the separation between the equipment and receiver.
- Connect the equipment into an outlet on a circuit different from that to which the receiver is connected.
- Consult the dealer or an experienced radio/TV technician for help.

This equipment complies with FCC radiation exposure limits set forth for an uncontrolled environment. This transmitter must not be co-located or operating in conjunction with any other antenna or transmitter.