

AUTO SECURITY
MAGICAR

USER'S GUIDE

One-Way AM Remote / Alarm Controllers

FCC ID : O44JR200AMEN

This device complies with Part 15 of the FCC Rules.

Operation is subject to the following two conditions :

- (1) This device may not cause harmful interference, and
- (2) This device must accept any interference received, including interference that may cause undesired operation.

CAUTION : Changes or modifications not expressly approved by the party responsible for compliance could void the user's authority to operate this device.

USER'S GUIDE

By Youngshin Electronics Co., Ltd.

www.magicar.com

YOUNGSHIN
Electronics Co., Ltd.

Website: www.magicar.com

User's GUIDE

User's GUIDE TABLE OF CONTENTS

Safety Information	Page 4
Remote : R200	Page 4
Remote Button Functions	Page 5
Remote Learning Routine	Page 5
Keyless Entry	Page 6
Alarm Mode	Page 6
Trunk Release	Page 7
Panic Mode	Page 7
Valet Mode	Page 7
Optional Programmable Features	Page 8
<i>Ignition Lock</i>	Page 8
<i>Passive Locking</i>	Page 8
Optional Installation Features	Page 8
<i>Door pulse Duration</i>	Page 8
<i>Flashing Signal Light</i>	Page 8
<i>Anti-jacking</i>	Page 8

Safety Information

Please take these safety precautions into consideration, under the following conditions :

1. Servicing the vehicle

When servicing your automobile (i.e. changing the oil, washing your car), the Magicar system should be in Valet Mode.

2. Loaning your vehicle to others

Whenever you loan your vehicle to an individual who is not familiar with Magicar, please put the vehicle in Valet mode. This will prevent the vehicle barrower from accidentally activating the Magicar auto-security system.

Remote

The model name, R200 stands for One Way AM 4 Button Remote.



Remote Button Functions

	Button	Press	Function
1		0.5 sec	Lock
2		0.5 sec	Unlock
3		0.5 sec	Siren Chirps for Lock /Unlock - on/off
4		0.5 sec	Valet Mode - on/off
5		2 sec	Panic, Press Lock to shut off Siren
6		0.5 sec	Ignition Lock - on/off
7		0.5 sec	Passive Arming - on/off
8		0.5 sec	Shock Sensor - on/off
9		2 sec	Trunk Release
10		2 sec	Programming Menu - Installer Only

Note : " — " Means pressing the button for 2 seconds.

" ()" Means simultaneously pressing the buttons.

" ()—" Means simultaneously pressing the buttons for 2 seconds.

Remote Learning Routine

The Magicar will allow up to three remotes to be programmed to one vehicle. Please perform the following procedure to add or reprogram additional remotes.

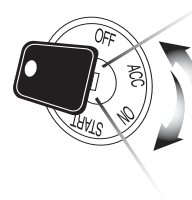



Step1: Activate Valet/ Programming mode by manually turning the ignition on and off three times (between Acc and On) with the key within a 7 second period.





The parking lights will flash once with successful completion of this step.

Step2 : Within a 7 second period after cycling the ignition for the 3rd time,
Press the  button for a 0.5 second. The parking lights will flash
once to confirm that the transmitter has been programmed.
You can continue programming additional remotes. The parking lights
will flash two times when the programming mode has expired.

Keyless Entry

To lock the vehicle, pressing the  button for a 0.5 second.
To unlock the vehicle, press the  button for a 0.5 second. If the pressing of the
lock/unlock buttons does not lock/unlock the doors, you will need to release the
button and try again, as the remote stops transmitting as soon as the LED stops
flashing. If the  button is pressed for 2 seconds, it will panic the system.

Alarm Mode

To arm the vehicle, press the  button .
To disarm the vehicle, press the  button.
If pressing the arm/disarm buttons does not arm/disarm the vehicle, you will need to
release the button and try again, as the remote stops transmitting as soon as the
LED stops flashing.
Press the ( + ) buttons for a 0.5 second to mute the vehicle siren when
arming or disarming your vehicle. Keep in mind that your siren will still be activated
for all other modes(i.e.panic or alarm trigger) regardless of whether or not your siren
is in mute mode. The siren will be mute only when arming or disarming your vehicle.



When the alarm is armed, the starter kill function (an optional feature provided by
your installer) is activated. This feature disengages the starter mechanism on your
vehicle and prevents it from starting, even with a key.

Note : If you lose your remote after you have armed the vehicle, use your key
to open the door. The siren will go off. Turn the ignition on and off,
3 times with your key to shut down the alarm and put the system into
valet mode. You can cancel valet mode with a remote later on.
See: Valet mode, on page 7.

Trunk Release

Press the  button for 2 seconds, in order to unlock and release your trunk door.
If pressing the trunk release button does not release the trunk, you will need to
release the button and try again, as the remote stops transmitting as soon as the
LED stops flashing. Note that the trunk release function will not only release the trunk
but will unlock the all doors as well.

Panic Mode



Press the  button for 2 seconds to enter Panic Mode. In this mode, the car will be
armed, if not armed already, and the siren will be activated and the parking lights will be
flashed. In order to disengage Panic Mode, press the  button.
Then, press the  button for a 0.5 second to unlock/ disarm your vehicle.

If **Anti-Jacking** option has been programmed (ask your dealer if you would
like to have this option) and the Ignition-Kill has been installed, Panic
Mode works as Anti-Jacking if the car key in the ignition. In Anti-Jacking
mode is activated while key is in the ignition,



a) the Siren will go off for 1.5 minutes, and b) Ignition-Kill will be activated
after the first 30 seconds. This is to give a 30 second warning to the
hijacker, then to disconnect the ignition to stop the vehicle.

Valet Mode

While the vehicle is in valet mode, the only feature is the keyless entry and optional auxiliary
functions.

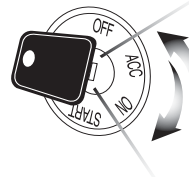
In order to enter Valet mode, press the ( + ) buttons simultaneously for a 0.5 sec-
ond. In order to manually enter Valet Mode, insert your car key into the ignition and turn the
ignition on and off (between ACC and ON) three times within 7 seconds



You can exit Valet Mode only by pressing buttons
( + ) simultaneously.



OPTIONAL PROGRAMMABLE FEATURES

These additional features may be programmed to the Magicar system by your authorized Magicar dealer.

Ignition Lock

This programmable option enables your vehicle to automatically lock the doors once the key is in the ignition for 30 Seconds.(Also you can lock the doors, If you step on the brake pedal within 30 Seconds) In addition, the vehicle will automatically unlock the doors when the key is pulled out of the ignition.

Passive Locking

You can turn this function on or off by pressing the ( + ) buttons for a 0.5 second. When setting to passive locking, your system will lock automatically 30 seconds after all the car doors are closed.

OPTIONAL INSTALLATION FEATURES

- Door Lock/ Unlock, Pulse Duration: if you set this mode, Door Lock/Unlock Pulse Duration will be changed 0.8 second to 4 seconds.
Anti-Jacking: It can be programmed to send a signal to a relay to disconnect the ignition wire of the vehicle upon anytime the vehicle is armed so that the vehicle cannot start or run by a remote or a key.
And the running of vehicle can be shut off by remote's panic command.
Start-Kill : It can be programmed to send a signal to a relay to disconnect the starter wire of the vehicle upon arming.
- Flashing Signal Lights during Door Open: When you leave your car without closing the doors, the signal lights will flash.

INSTALLATION GUIDE

INSTALLATION GUIDE TABLE OF CONTENTS

Installation Tips & Recommendations	Page 10
R200 Wiring Diagram	Page 11
CON 1	Page 12
CON 2	Page 13
CON 3	Page 14
CON 4	Page 16
CON 5	Page 16
Antenna	Page 16
Option Mode	Page 17
Programming Menu Option	Page 17
How to set Options	Page 18
Canceling(Going to Factory Default)Option Mode	Page 19
Confirmation of Wrong Programming	Page 19

Installation Tips & Recommendations

1-1. Please be careful not to lock yourself out.

Please lower the glass windows before you start the installation in case the door locks with the key inside. Also, learn the remote to the brain module after the installation has been completed.

1-2. Use Digital Multimeter for testing

Use a Digital Multimeter for all testing of wires in the vehicle. This should be done on all wires even if you feel that you know exactly what they are and how they should test. Use of lamp tester may damage the electrical circuit of the vehicle.

1-3. Find Good Ground

One of the most important wire connections is the ground connection. Please find a spot that does not have any resistance to the battery ground. Improper ground will result in malfunction of the system.

1-4. Make sure your installation does not become a driving hazard later to the driver.

During installation process, please try to foresee there are any potential problems to the driver later.

Potential Driving Hazards

There should be no wiring around the brake.

Connection problem or Insulation problem

Please make sure all the connections are done by soldering and are properly insulated by electrical tape.

Will any of your installation be affected by the vibration and engine heat during driving?

Tie securely every components of your installation by use of bolts or cable tie.

Be sure that engine heat will not damage any wiring inside of the engine compartment.

Organizing wiring after the installation

Improper wiring organization will result in electrical noise, connection problems, safety hazards.

User's familiarity with operating manual

Installer should thoroughly explain system operation to the user.

1-5. Vehicle check-up prior to and after the installation.

For your protection, check the vehicle inside and out including all of the vehicle operating conditions and various factory systems to make sure they work properly after installation in the same manner as prior to the installation.

M861A Wiring Diagram

CON1	1	RED	(+)12V Constant Input	
	2	Violet	(+)Parking Light Output	
	3	Brown	(+)Siren Output	
	4	Gray	(+)Trunk Output	
	5	Black	Ground	
CON2	1	Yellow/Black	N.C.	Unlock
	2	Yellow	COM.	
	3	Yellow/White	N.O.	Lock
	4	Green/Black	N.C.	
	5	Green	COM.	
	6	Green/White	N.O.	
CON3	1	Green	(+)Ignition Sensing	
	2	Blue	(-)250mA Output to Starter Kill	
	3	Red/Black	(-)Door Pin Sensing	
	4	Red	(+)Door Pin Sensing	
	5	Violet/Black	(-)Trunk Pin Sensing	
	6	Light Blue/White	(+)Brake Sensing	
	7	Black/White	(-)Optional Sensor Input	
CON4	1	Black	Ground	
	2	Black/White	(+)LED	
CON5	1	Black	Ground	
	2	White	(-)2nd Stage Shock Input	
	3	Red	(+)12V Output	
	4	Yellow	(-)1st Stage Shock Input	
Antenna		Black		

CON1

No 1 (Red) : (+)12V Input

Solder this wire to the vehicle's 12V constant. This wire must be supplied power all of the time and must be able to withstand high current draw.

No 2 (Green/ White) : (+)Output for parking Light

Positive parking light output.

No 3 (Brown) : (+)12V Siren Output

The Black wire at the siren is to be chassis grounded.

The siren volume can be reduced by cutting the volume wire attached to the siren.

No 4 (Gray) : (+)12V Trunk Output

If the vehicle is equipped with electrical trunk release, the trunk out is connected to trigger the trunk solenoid.

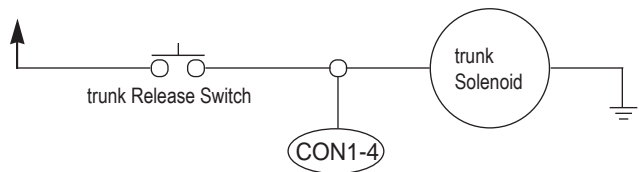

No 5 (Black) : Chassis Ground

This will be the one of the most important connections. Connect this wire to bare metal of the vehicle. We do not recommend using the steering column for a grounding point. Make sure you strip back the paint or use a factory grounding point. Bad grounding on this wire will be the beginning of future troubles.

CON2

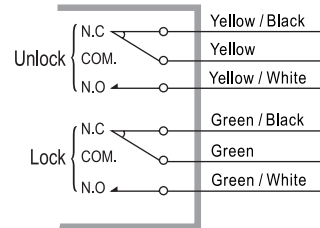

< Circuit diagram >

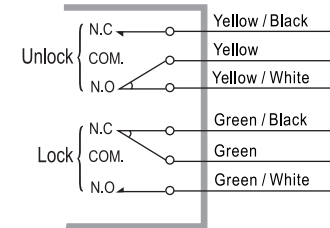

< Circuit diagram during unlock output >

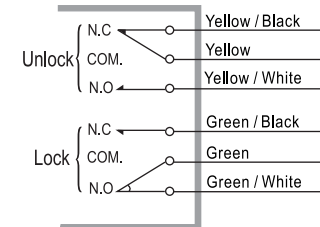

< Circuit diagram during lock output >

Installers are able to install as per the following methods when you install, please find a suitable method as per the door system of your vehicle

The Wires of CN2 are not connected with any part of inside
Connect +12V to the wire placed between the Connector and the Fuse (20A)

Method 1 :
Negative Trigger Door Lock System
(W/O Actuator)

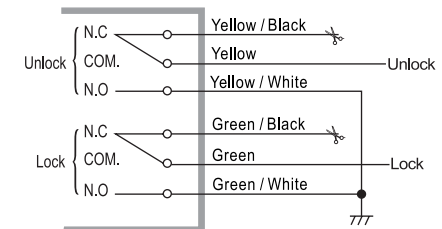

-Method 2 :
Positive Trigger Door Lock System
(W/O Actuator)

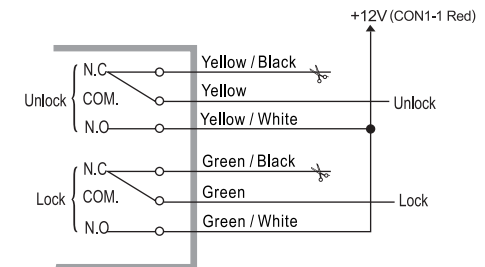

Method 3 : External Actuator

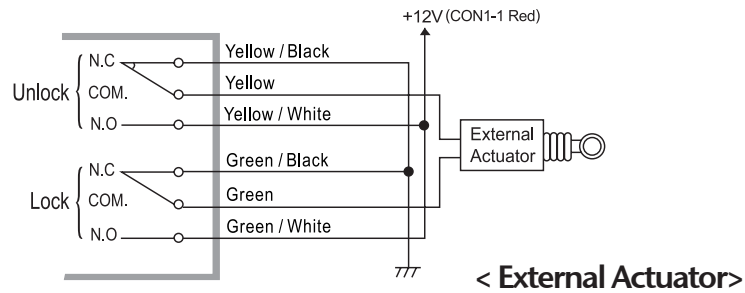

CON3

No 1 (Green) : (+12V) Ignition Input

This wire will test (using your digital multi-meter) 0V with the key off, and 12V with the key in the 'ON or RUN' position

No 2 (Blue) : Negative Starter-Kill Output

Please use the pre-wired starter kill relay.

.... Starterkill Mode ...

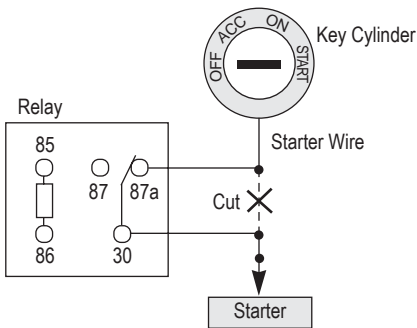

.... Anti Jacking Mode ...

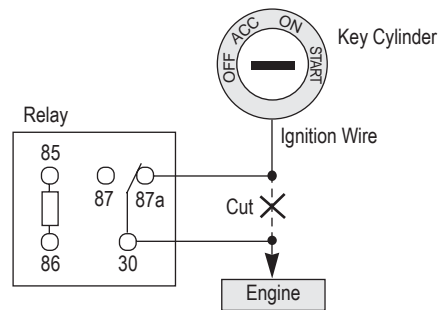

No 3 (Red/Black) : Negative Trigger Door Open Sense

No 4 (Red) : Positive Trigger Door Open Sense

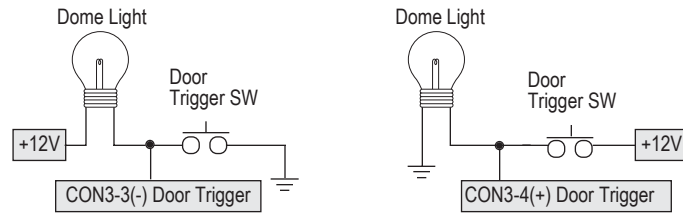

Please make sure you have found a correct door sensing wire that monitors all doors.

No 5 (Violet / Black) : (-) Trunk Trigger Input.

connect this to wire to the trunk lamp wire as shown below

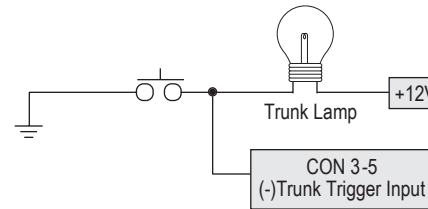

No6 (Light Blue / White) : (+) Brake Trigger Input

Connect this wire to the foot Brake Wire as shown below.

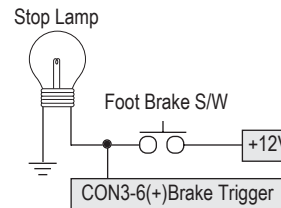

No7 (Black /White) : (-) Input for optional Sensor

When installing additional sensors, use this wire as the input wire for those sensors.
Always remember, when attaching more than one sensor to any input, you must diode isolate them so that they don't backfeed into each other.

CON4

No 1 (Black) : GND
No 2 (Black/White) : (+)LED } LED Ass'y

CON 5

No 1 (Black) : GND
No 2 (White) : (-)and stage shock Input
No 3 (Red) : (+12)
No 4 (Yellow) :(-)1st stage shock Input } Dual stage shock sensor



Antenna



When Magicar systems are installed, please pay attention to stretch out the wire of antenna. If the wire is bended or twisted seriously, it will be one of the reasons, which will reduce the receiving range.

Antenna Module

FCC ID: O44J1WAMLEDANT

Options Mode +

Press buttons  and  Simultaneously for 2 seconds in order to enter Option Mode.

	Features	 (Factory Default)	
1	Door Lock/Unlock Pulse Duration	0.8 Sec	4 Sec
2	Application of Pre-wired Kill Relay	Starter Kill	Anti-jacking (IG-kill)
3	Flashing Parking Light During Door Open	Disabled	Activated

Programming Menu Option

Note :

1. Door Lock/Unlock Pulse Duration :

If you set this mode, Door Lock/Unlock Pulse Duration will be changed 0.8 second to 4 seconds.

2. Start Kill Mode

Anti-Jacking(Ignition-Kill) :

The #2 wire of CON3 can be programmed to send a signal to a relay to disconnect the ignition wire of the vehicle anytime the vehicle is armed so that the vehicle cannot start or run by remote or key. The vehicle can also be shut off with remote by use of the panic command, even if it is running with a key in the ignition.

Starter-Kill :



The #2 wire of CON3 can be programmed to send a signal to a relay to disconnect the starter wire of the vehicle upon arming.

3. Parking Light Flashing :

With this option, the parking lights will flash if any door remains open while the vehicle is disarmed.

How to set Options

You can only program one option at a time. You will have to repeat the procedure for every option you would like to change.

Step1: Press buttons ( + ) for 2 seconds. The siren and signal lights will chirp and flash one time each.

- If you fail to program, the siren and signal lights will chirp and flash three times each.

Step2: Press button  the number of times to go to the option number you want to change.

- The siren and signal lights will chirp and flash one time whenever you press button  .

Step3: Wait a few seconds. You will hear a number of chirps and see a number of parking light flashes corresponding to the option number you want to change. If the number of chirps or flashes does not match the option number you want, wait 10 seconds, then start over at step 1.





Step4: Press button  or  as you want to program the option.

- If you press button  , the option will be set to the default setting. The siren and signal lights will chirp and flash one time each.



- If you press button  , the option will be set to the optional setting. The siren and signal lights will chirp and flash two times each.

EX) When you would like to program Option 3 which is for Flashing parking

Light during door open

1. Press button ( + ) for 2 seconds (The siren and signal lights will chirp one time each)
2. Press button  three times (The siren and signal lights will chirp and flash one time whenever press button ) and wait for 5 seconds.
3. The siren and signal lights will chirp and flash three times after 5 seconds
4. Press button  after confirmation of the siren and signal lights as no. 3 (The siren and signal lights will chirp and flash two times each.)

Canceling (Going to factory default) Option Mode

Step1: Press buttons ( + ) for 2 seconds (The siren and signal lights will chirp and flash one time each).

- If you fail to program, the siren and lights will chirp and flash three times each.

Step2: Press button  three times. (The siren and signal lights will chirp and flash once time the button is pressed.)

Step3: All options will be reset to factory defaults after the confirming 3 chirps and flashes.

Confirmation of Wrong Programming

When you press the buttons incorrectly, Option Mode will not be programmed and the siren will activate for 1 second.