

WallMote Quad (User Guide)

Modified on: Wed, 7 Dec, 2016 at 7:48 PM

WallMote Quad.

Aeotec WallMote Quad is an intelligent Z-Wave remote controller that mounted on a wall. It has 4 touch buttons that you can easily control the Z-Wave devices in your home network via touching, long pressing or sliding the button areas.

Its surface has a RGB LED to indicate the button actions also accompanied by touch beep and vibration.

The WallMote Quad is also a security Z-Wave device and supports Over The Air (OTA) feature for the products firmware upgrade.

Familiarize yourself with your WallMote Quad.

1. WallMote Quad
2. Back-Mount plate
3. Double-Sided tape
4. Micro USB cable

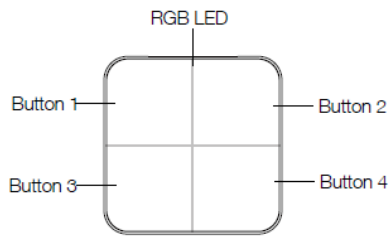

Main unit (Front)

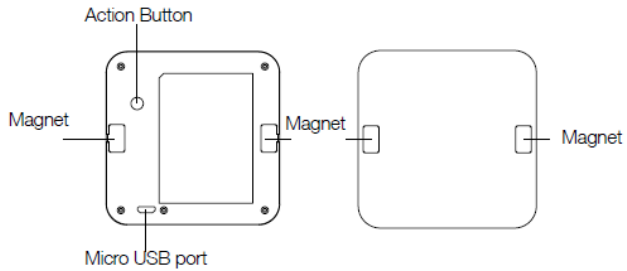

Main unit (Back)

Back-Mount plate

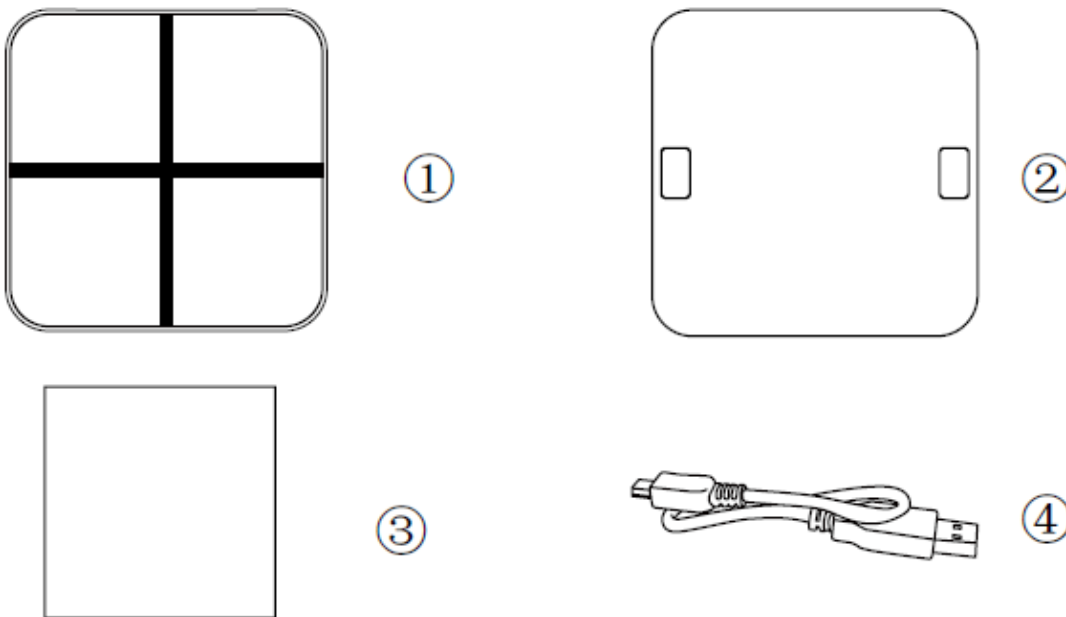

Note: When the WallMote is placed on somewhere, keep the glass button surface upward direction and no other physical surface or desktop contact with the glass button surface to avoid false triggering and battery consumption.

Quick start.

Installing your WallMote Quad.

1. Selecting a place or wall in your home to affix your WallMote Quad's Back Mount plate.

2. Using the Double-sided tap, wipe the two surfaces clean of any oil or dust with a damp towel. When the surface has completely dried, peel one side of the tape back and attach it to the corresponding section on the rear side of the Back Mounting Plate.

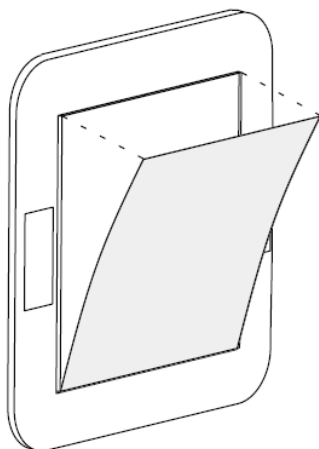

Adding your WallMote Quad to your Z-Wave network.

With your mounting plates prepared to hold each component of your WallMote Quad, it's time to add it to your Z-Wave network.

1. Let your Z-Wave primary controller/gateway enter into pairing/
2. inclusion mode.
3. Take your WallMote Quad near to your primary controller. Press the Action Button once on your WallMote Quad, the LED will blink with green color.
4. If your WallMote Quad has been successfully added to your Z-Wave network, its green LED will be solid for 2 seconds and then off. If the adding was unsuccessful and the red LED will be solid for 2 seconds and then off, repeat the above steps.

With your WallMote Quad now working as a part of your smart home, you'll be able to configure it from your home control software or phone application. Please refer to your software's user guide for precise instructions on configuring the WallMote Quad to your needs.

Attach your WallMote Quad to its Back Mounting plate.

With your WallMote Quad added to the Z-Wave network. It's now time to insert the main unit into the corresponding Back Mount plate. Put the main unit in the top-left direction on the Back Mounting, and then push the WallMote Quad into the Back Mounting Plate, the WallMote Quad will be attracted by the magnets on the Back Mount plate, as the figure below shows.

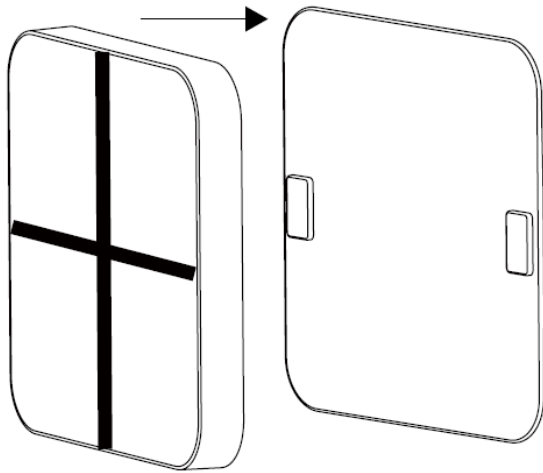

Advanced Functions.

Send a wake up notification.

In order to send your WallMote Quad new configuration commands from your Z-Wave controller or gateway, it will need to be woken up.

Remove your WallMote Quad unit from its Back Mounting Plate, press and hold the Action Button for 3 seconds (the buzzer chirp once and the orange LED will be ON) on the back of the WallMote Quad unit and then release it. This will trigger and send a wake up notification command to your controller/gateway, then your WallMote Quad will wake up for 10 minutes and the orange LED will fast blink while it is awake (if the WallMote Quad does not receive the Wake Up No More Info from the primary Controller).

Removing your WallMote Quad from a Z-Wave network.

Your WallMote Quad can be removed from your Z-Wave network at any time. You'll need to use your Z-Wave network's main controller/gateway. To do this, please refer to the part of their respective manuals that tell you how to remove devices from your network.

1. Put your primary controller into device removal mode.
2. Unlock your WallMote Quad from the Back Mount plate and take the WallMote Quad unit near to your primary controller.
3. Press the Action Button on your WallMote Quad.
4. If your WallMote Quad is successfully removed from the Z-Wave network, the LED will become a colorful gradient for a few seconds and then turn off. If the removing was unsuccessful, the red LED will be solid for 2 seconds and then turn off, repeat the above steps.

Security or Non-security feature of your WallMote Quad in Z-wave network.

Including WallMote Quad as a non-secure device:

If you want your WallMote Quad as a non-security device in your Z-wave network, you just need to press the Action Button once on WallMote Quad when you use a controller/gateway to add/include it.

The green LED will be on for 2 seconds and then the orange LED will fast blink for 10 minutes (if the WallMote Quad does not receive the Wake Up No More Info command from primary Controller) to indicate the inclusion is successful.

Including WallMote Quad as a secure device:

In order to take full advantage of all functionality the WallMote Quad, you may want your WallMote Quad is a security device that uses secure/encrypted message to communicate in Z-wave network, so a security enabled controller/gateway is needed for the WallMote Quad to be used as a security device.

You need to press the WallMote Quad's Action Button 2 times within 1 second when your security controller/gateway starts the network inclusion.

The blue LED will be on for 2 seconds and then the orange LED will fast blink for 10 minutes (if the WallMote Quad does not receive the Wake Up No More Info command from primary Controller) to indicate the inclusion is successful.

Advanced Parameter Configurations.

Not all gateways will allow you to further configure your Z-Wave devices, but in the case that your gateway does allow it, the WallMote Quad has some available parameter configurations that will allow you to configure it further to your liking.

Touch beep

This will enable or disable the sound effects when you press or touch the sensing area. By default, this is enabled.

Parameter 1 [1 byte]

0: Disable

1: Enable

Note: You can also enable or disable the sound effects via pressing and holding the Action Button for 12 seconds (the buzzer chirp once and the red LED will fast blink) and then release.

Touch vibration

This will enable or disable the vibration effects when you press or touch the sensing area. By default, this is enabled.

Parameter 2 [1 byte]

0: Disable

1: Enable

Note: You can also enable or disable the vibration effects via pressing and holding the Action Button for 17 seconds (the buzzer chirp once and the red LED will be solid) and then release.

Association table of the control buttons.

The WallMote Quad supports 9 association groups, all control buttons can activate the configured scenes via sending the Central Scene Notifications to primary controller/gateway (In association group 1). In order to use Association Groups, make sure that your gateway or software can allow you to set these, in order to do so, please refer to your gateways manual on setting group association. This will allow the WallMote Quad to directly communicate ON/OFF or Dimming commands to your devices without going through your gateway.

Every control button also can send the control commands to control the devices in the other association groups, see the table below:

| Association Group | Control Button | Control commands | Description |
|-------------------|----------------|----------------------------|---|
| 1 (Lifeline) | Button 1 to 4 | Central Scene Notification | Central Scene control via Button 1 to 4 |
| 2 | Button 1 | Basic Set | On/Off control via Button 1 |
| 3 | Button 1 | Multilevel Switch Set | Dimmer control via Button 1 |
| 4 | Button 2 | Basic Set | On/Off control via Button 2 |
| 5 | Button 2 | Multilevel Switch Set | Dimmer control via Button 2 |
| 6 | Button 3 | Basic Set | On/Off control via Button 3 |
| 7 | Button 3 | Multilevel Switch Set | Dimmer control via Button 3 |
| 8 | Button 4 | Basic Set | On/Off control via Button 4 |
| 9 | Button 4 | Multilevel Switch Set | Dimmer control via Button 4 |

Dimmer control via sliding the button area.

The WallMote Quad also supports sliding control, when the parameter 4 [1 byte] has been set to 3, you can slide up or down on the button area to control a dimmer device by sliding up or down. Swiping up once will dim up a dimmer device by a certain percentage, while swiping down once will dim down a dimmer device by a certain percentage.

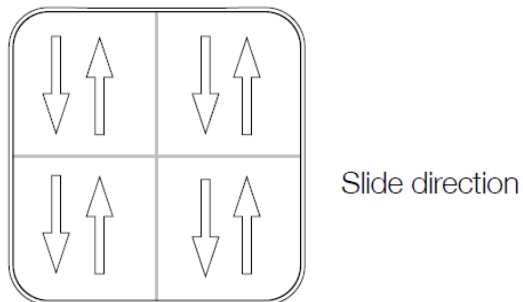

Your WallMote Quad's battery.

Your WallMote Quad has a internal rechargeable lithium battery that will allow you to charge it when it is in low battery. The charger's output should be a micro USB terminal with the specification of output DC 5V/1A. When the WallMote Quad is in charge state, the orange LED will be on. If the orange LED is off and the green LED remains on, then it indicates that the battery charge is complete.

Note: When the WallMote is in low battery, you will see the orange LED will blink when you touch the control buttons. Otherwise, if the blue LED blinks when touching the buttons, which means the battery is in normal level.

Resetting your WallMote Quad.

If at some stage, your primary controller is missing or inoperable, you may wish to factory reset your WallMote Quad's which will remove it from its network that it is paired to, and reset all configured settings back to default. To do this, follow the steps below:

1. Press and hold the Action button (20 seconds).
2. The LED should blink between green, purple, then red which will flash rapidly until a green LED becomes solid for 2 seconds to indicate a successful factory reset.
3. Let go of the Action Button.

Technical Specifications

Model number: ZW130.

Power supply: Rechargeable lithium battery, 3.7 V, 640mAh.

Battery charger input: Micro USB port, DC 5V±0.5V, max 1A.

Operating temperature: 0°C to 40°C.

Relative humidity: 8% to 80%.

Operating distance: Up to 394 feet/120 metres outdoors.

Known Uses for various Gateways

1. **Smarthings Hub** (<https://aeotec.freshdesk.com/solution/articles/6000162573-wallmote-quad-smarthings-hub-custom-device-handler-by-erocm123>) (Custom Device Handler by Erocm123)
2. Vera UI7 Group Association (Article coming soon)