



IP1000/1050

Europe – EU Declaration of Conformity

This device complies with the essential requirements of the R&TTE Directive 1999/5/EC. The following test methods have been applied in order to prove presumption of conformity with the essential requirements of the R&TTE Directive 1999/5/EC:

This device is a 2.4 GHz wideband transmission system (transceiver), intended for use in all EU member states and EFTA countries, except in France and Italy where restrictive use applies.

In Italy the end-user should apply for a license at the national spectrum authorities in order to obtain authorization to use the device for setting up outdoor radio links and/or for supplying public access to telecommunications and/or network services.

This device may not be used for setting up outdoor radio links in France and in some areas the RF output power may be limited to 10 mW EIRP in the frequency range of 2454 – 2483.5 MHz. For detailed information the end-user should contact the national spectrum authority in France.

Clause	Description
EN 60950-1: 2001	Safety of Information Technology Equipment
EN 50392: 2004	Generic standard to demonstrate the compliance of electronic and electrical apparatus with the basic restrictions related to human exposure to electromagnetic fields (0 Hz - 300 GHz)
EN 300 328 V (2004-11)	Electromagnetic compatibility and Radio spectrum Matters (ERM); Wideband transmission systems; Data transmission equipment operating in the 2,4 GHz ISM band and using wide band modulation techniques; Harmonized EN covering essential requirements under article 3.2 of the R&TTE Directive
EN 301 489-17 V (2002-08) and EN 301 489-1 V1.5.1 (2004-11)	Electromagnetic compatibility and Radio spectrum Matters (ERM); ElectroMagnetic Compatibility (EMC) standard for radio equipment and services; Part 17: Specific conditions for 2,4 GHz wideband transmission systems and 5 GHz high performance RLAN equipment

Europe – EU Declaration of Conformity

Česky [Czech]	[Jméno výrobce] tímto prohlašuje, že tento [typ zařízení] je ve shodě se základními požadavky a dalšími příslušnými ustanoveními směrnice 1999/5/ES.	Lietuvių [Lithuanian]	Šiuo [manufacturer name] deklaruoja, kad šis [equipment type] atitinka esminius reikalavimus ir kitas 1999/5/EB Direktyvos nuostatas.
Dansk [Danish]	Undertegnede [fabrikantens navn] erklærer herved, at følgende udstyr [udstyrets typebetegnelse] overholder de væsentlige krav og øvrige relevante krav i direktiv 1999/5/EF.	Nederlands [Dutch]	Hierbij verklaart [naam van de fabrikant] dat het toestel [type van toestel] in overeenstemming is met de essentiële eisen en de andere relevante bepalingen van richtlijn 1999/5/EG.
Deutsch [German]	Hiermit erkläre [Name des Herstellers], dass sich das Gerät [Gerätetyp] in Übereinstimmung mit den grundlegenden Anforderungen und den übrigen einschlägigen Bestimmungen der Richtlinie 1999/5/EG befindet.	Malti [Maltese]	Hawnhekk, [isem tal-manifattur], jiddikjara li dan [il-mudel tal-prodott] jikkonforma mal-ħtiġijiet essenzjali u ma provvedimenti oħrajn rilevanti li hemm fid-Dirrettiva 1999/5/EC.
Eesti [Estonian]	Käesolevaga kinnitab [tootja nimi = name of manufacturer] seadme [seadme tüüp = type of equipment] vastavust direktiivi 1999/5/EÜ põhinõuetele ja nimetatud direktiivist tulenevatele teistele asjakohastele sätetele.	Magyar [Hungarian]	Alulírott, [gyártó neve] nyilatkozom, hogy a [... típus] megfelel a vonatkozó alapvető követelményeknek és az 1999/5/EC irányelv egyéb előírásainak.
English	Hereby, [name of manufacturer], declares that this [type of equipment] is in compliance with the essential requirements and other relevant provisions of Directive 1999/5/EC.	Polski [Polish]	Niniejszym [nazwa producenta] oświadczam, że [nazwa wyrobu] jest zgodny z zasadniczymi wymogami oraz pozostałymi stosownymi postanowieniami Dyrektywy 1999/5/EC.
Español [Spanish]	Por medio de la presente [nombre del fabricante] declara que el [clase de equipo] cumple con los requisitos esenciales y cualesquiera otras disposiciones aplicables o exigibles de la Directiva 1999/5/CE.	Português [Portuguese]	[Nome do fabricante] declara que este [tipo de equipamento] está conforme com os requisitos essenciais e outras disposições da Directiva 1999/5/CE.
Ελληνική [Greek]	ΜΕ ΤΗΝ ΠΑΡΟΥΣΑ [name of manufacturer] ΔΗΛΩΝΕΙ ΟΤΙ [type of equipment] ΣΥΜΜΟΡΦΩΝΕΤΑΙ ΠΡΟΣ ΤΙΣ ΟΥΣΙΩΔΕΙΣ ΑΠΑΙΤΗΣΕΙΣ ΚΑΙ ΤΙΣ ΛΟΙΠΕΣ ΣΧΕΤΙΚΕΣ ΔΙΑΤΑΞΕΙΣ ΤΗΣ ΟΔΗΓΙΑΣ 1999/5/ΕΚ.	Slovensko [Slovenian]	[Ime proizvajalca] izjavlja, da je ta [tip opreme] v skladu z bistvenimi zahtevami in ostalimi relevantnimi določili direktive 1999/5/ES.
Français [French]	Par la présente [nom du fabricant] déclare que l'appareil [type d'appareil] est conforme aux exigences essentielles et aux autres dispositions pertinentes de la directive 1999/5/CE.	Slovensky [Slovak]	[Meno výrobcu] týmto vyhlasuje, že [typ zariadenia] spĺňa základné požiadavky a všetky príslušné ustanovenia Smernice 1999/5/ES.
Italiano [Italian]	Con la presente [nome del costruttore] dichiara che questo [tipo di apparecchio] è conforme ai requisiti essenziali ed alle altre disposizioni pertinenti stabilite dalla direttiva 1999/5/CE.	Suomi [Finnish]	[Valmistaja = manufacturer] vakuuttaa täten että [type of equipment = laitteen tyyppimerkintä] tyyppinen laite on direktiivin 1999/5/EY oleellisten vaatimusten ja sitä koskevien direktiivin muiden ehtojen mukainen.
Latviski [Latvian]	Ar šo [name of manufacturer / izgatavotāja nosaukums] deklarē, ka [type of equipment / iekārtas tips] atbilst Direktīvas 1999/5/EK būtiskajām prasībām un citiem ar to saistītajiem noteikumiem.	Svenska [Swedish]	Härmed intygar [företag] att denna [utrustningstyp] står i överensstämmelse med de väsentliga egenskapskrav och övriga relevanta bestämmelser som framgår av direktiv 1999/5/EG.

Federal Communication Commission Interference Statement

This equipment has been tested and found to comply with the limits for a Class B digital device, pursuant to Part 15 of the FCC Rules. These limits are designed to provide reasonable protection against harmful interference in a residential installation. This equipment generates, uses and can radiate radio frequency energy and, if not installed and used in accordance with the instructions, may cause harmful interference to radio communications. However, there is no guarantee that interference will not occur in a particular installation. If this equipment does cause harmful interference to radio or television reception, which can be determined by turning the equipment off and on, the user is encouraged to try to correct the interference by one of the following measures:

Reorient or relocate the receiving antenna.

Increase the separation between the equipment and receiver.

Connect the equipment into an outlet on a circuit different from that to which the receiver is connected.

Consult the dealer or an experienced radio/TV technician for help.

This device complies with Part 15 of the FCC Rules. Operation is subject to the following two conditions:

(1) This device may not cause harmful interference, and

(2) this device must accept any interference received, including interference that may cause undesired operation.

FCC Caution:

Any changes or modifications not expressly approved by the party responsible for compliance could void the user's authority to operate this equipment.

IEEE 802.11b or 802.11g operation of this product in the U.S.A. is firmware-limited to channels 1 through 11.

IMPORTANT NOTE

FCC Radiation Exposure Statement

This equipment complies with FCC radiation exposure limits set forth for an uncontrolled environment. This equipment should be installed and operated with minimum distance 20cm between the radiator & your body.

This transmitter must not be co-located or operating in conjunction with any other antenna or transmitter.

Table of Contents

Product Overview

- Introduction →
- Basic Connection →
- Application →

Hardware Installation

- Safety Instruction →
- Minimum System Requirement →
- Package Contents →
- Physical Description →
- Mounting and Cable Connecting →

EZvuu

- Live View →
- Client Setting →
- Camera Console →
- Remote Playback →
- Remote Record →
- OSD Toolbar →

Easy Access

- Web Browsers →
- Mobile Phone Viewing →
- Windows Live Messenger →

Live View

- Live View Control Panel →
- Setting →
- Client Setting →
- Image Setup →

Setting

- System →
- Camera →
- Network →
- Events →
- Help →

Appendix

- Frame Rate and Bitrate Table →
- Storage Requirement Table →



Table of Contents

Product Overview

Hardware Installation

EZvuu

Easy Access

Live View

Setting

Appendix

Product Overview

Introduction



Basic Connection

Wired Connection



Wireless Connection



Application



Table of Contents

Product Overview

Hardware Installation

EZvuu

Easy Access

Live View

Setting

Appendix

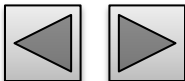

Introduction

The **IP1000/1050** is an ultra-compact IP Camera equipped with a high sensitivity progressive scan CMOS sensor, achieving high image quality and superior low-light performance. **IP1050** also supports 802.11b/g/n wireless connection with WPS.



Key Features:

- Maximum Resolution 640x480 (VGA)
- DDNS Supported
- Simultaneous MPEG-4 and Motion JPEG video stream
- up to flexible 30 fps in all resolution
- Wireless(IEEE 802.11g/b/n with WPS) Networks Connection(IP1050)**
- Two-way Audio with Built-In Microphone
- Support Mac OS**
- Support iPhone**
- Support Live Video Viewing on Windows Live Messenger**
- Mobile Phone Streaming Live Video through 3GPP / ISMA / RTSP
- Mobile Phone Live Image through 2.5 WAP
- Multi-level Password Protection for Restricting Camera Access
- Built-In Multi-Window Motion Detection (3 detection areas)
- Video Buffer makes the Streaming Smoother
- Support UPnP**
- Free Bundled Web-based 9 Channel Surveillance Software (EZvuu)**

Table of Contents

Product Overview

Hardware Installation

EZvuu

Easy Access

Live View

Setting

Appendix

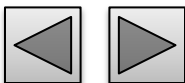

Basic Connection

Wired Connection

- 1. Connect the power adaptor to IP Camera.
- 2. Connect IP Camera' Ethernet port to your Hub/ Switch / Router

Wireless Connection (Only IP1050)

- 1. Connect the power adaptor to IP Camera.
- 2. Connect to Wi-Fi

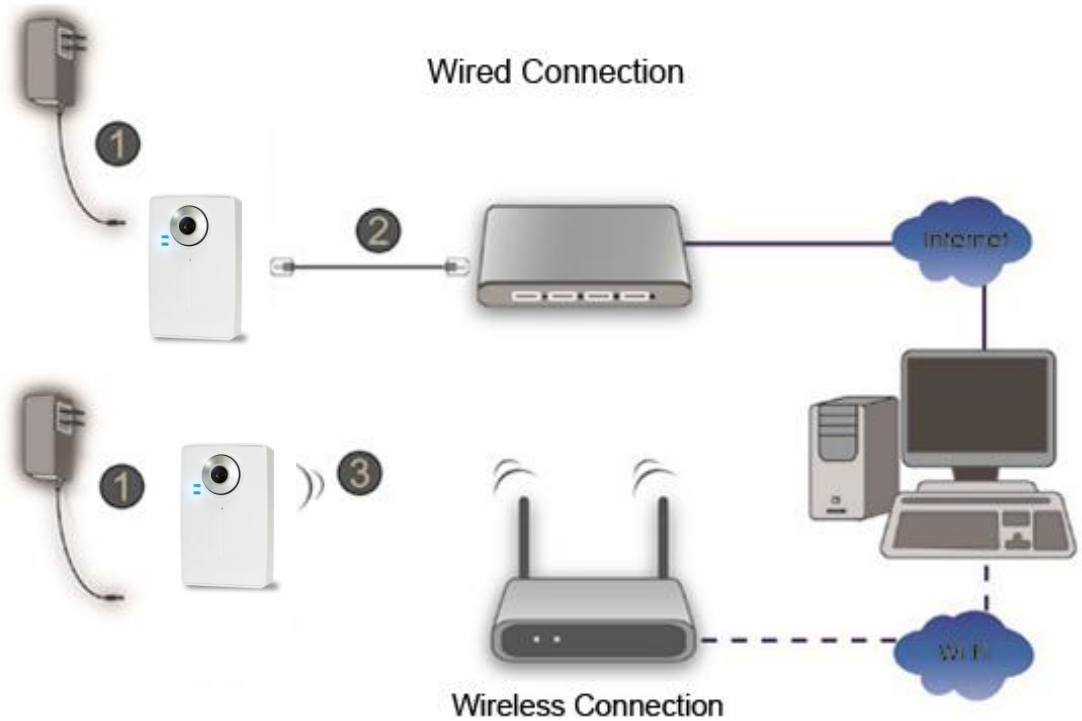

Table of Contents

Product Overview

Hardware Installation

EZvuu

Easy Access

Live View

Setting

Appendix

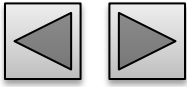

Application

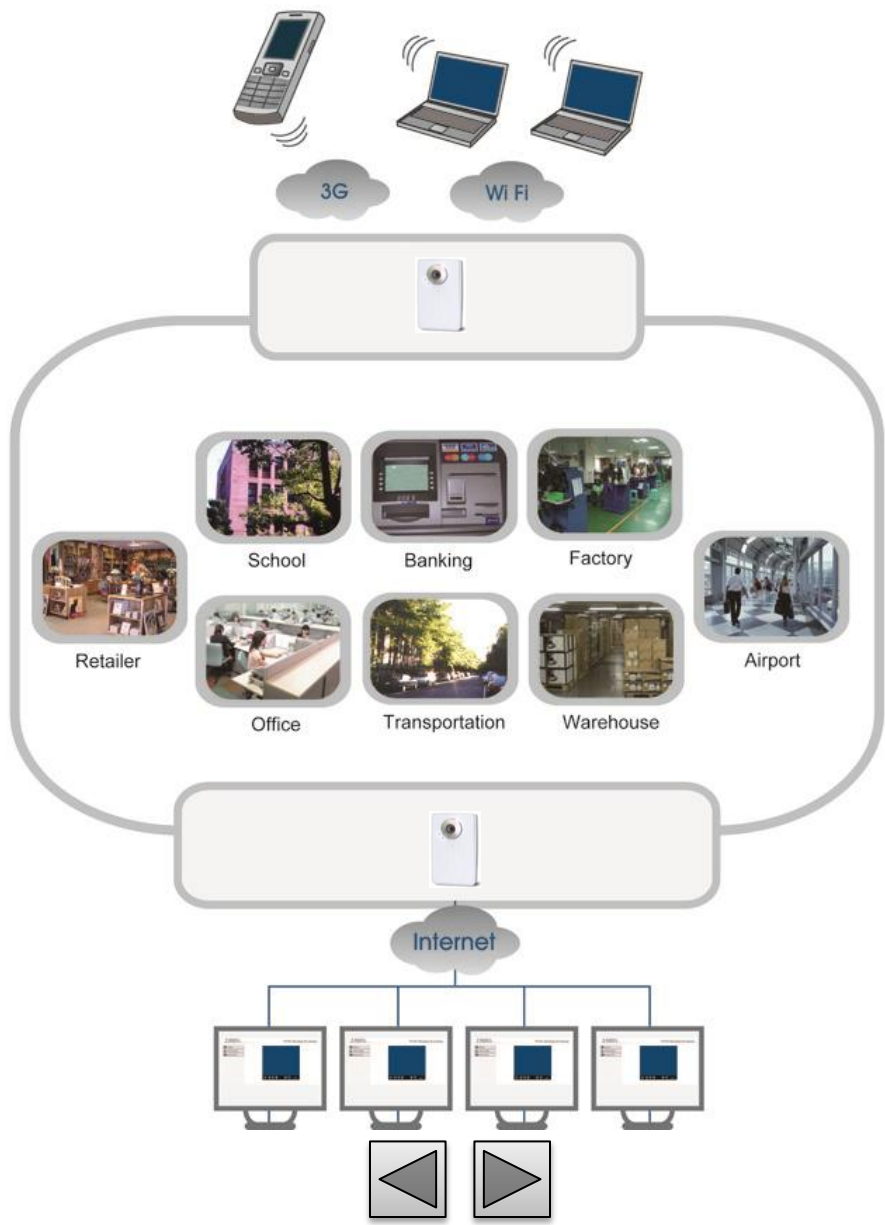

Table of Contents

Product Overview

Hardware Installation

EZvuu

Easy Access

Live View

Setting

Appendix

Hardware Installation







- Safety Instruction** 
- Minimum System Requirement** 
- Package Contents** 
- Physical Description**
 - Front View 
 - Bottom View 
- Mounting and Cable Connecting** 

Table of Contents

Product Overview

Hardware Installation

EZvuu

Easy Access

Live View

Setting

Appendix

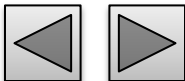

Safety Instruction

Before you use this product

This product has been designed with safety in mind. However, the electrical products can cause fires which may lead to serious body injury if not used properly. To avoid such accidents, be sure to heed the following.

Legal Caution

Video and audio surveillance can be forbidden by laws that vary from country to country. Check the laws in your local region before using this product for surveillance purposes.

Don't open the housing of the product

Don't try to open the housing or remove the covers which may expose yourself to dangerous voltage or other hazards.

Don't use the accessories not recommend by the manufacturer

Heed the safety precautions

Be sure to follow the general safety precautions and the "Operation Notice."

Operation Notice - Operating or storage location

Avoid operating or storing the camera in the following locations:

Extremely hot or cold places

(Operating temperature: 0 °C to + 50 °C [32 °F to 122 °F])

Exposed to direct sunlight for a long time, or close to heating equipment (e.g., near heaters)

Close to water (e.g., near a bathtub, kitchen sink, laundry tub)

Close to sources of strong magnetism

Close to sources of powerful electromagnetic radiation, such as radios or TV transmitters

Locations subject to strong vibration or shock

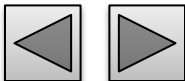

In case of a breakdown

In case of system breakdown, discontinue use and contact your authorized dealer.

In case of abnormal operation

If the unit emits smoke or an unusual smell,

If water or other foreign objects enter the cabinet, or

If you drop the unit or damage the cabinet:1 Disconnect the cable and the connecting cables. 2 Contact your authorized dealer or the store where you purchased the product.

Transportation

When transporting the camera, repack it as originally packed at the factory or in materials of equal quality.

Ventilation

To prevent heat buildup, do not block air circulation around the device.

Cleaning

Use a soft, dry cloth to clean the external surfaces of the device. Stubborn stains can be removed using a soft cloth dampened with a small quantity of detergent solution, then wipe dry.

Do not use volatile solvents such as alcohol, benzene or thinners as they may damage the surface.

Table of Contents

Product Overview

Hardware Installation

EZvuu

Easy Access

Live View

Setting

Appendix

Minimum System Requirement

Item	Requirements
CPU	Pentium 4 1600MHz (or equivalent AMD)
Graphic Card	64 MB RAM graphic cards(or equivalent on-board graphic cards)
RAM	512 MB
Operating System	Windows 98, Windows ME (Please see Note) Windows2000, 2003, XP, Vista, Windows 7, Mac OS X Leopard
Web Browser	Internet Explore 6 or later

Note

1. If you are using Windows 98 or Windows ME, please install IP Installer before using WEB UI to ensure the system runs normally.
2. If you can't view the record video file, please install Xvid codec while installing Intelligent IP Installer. (For Windows 98, ME or 2000 server, the codec might not work properly. You'll need to download Xvid codec 1.0 from the internet.
3. Please always update the latest Windows component. (Net Framework, Windows Media Player, Enhance ActiveX Security)

Table of Contents

Product Overview

Hardware Installation

EZvuu

Easy Access

Live View

Setting

Appendix

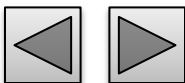

Package Contents

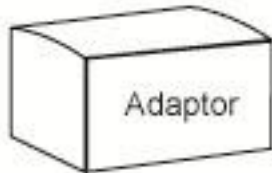
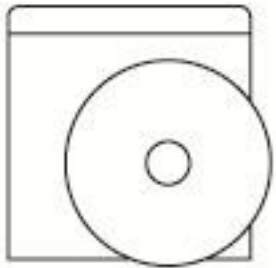
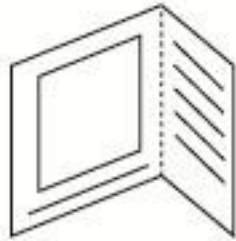
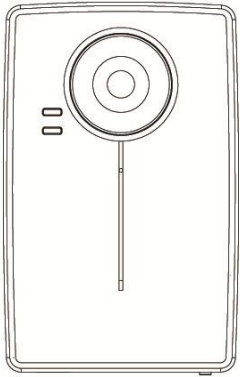

Camera – IP1000/IP1050 Network Camera
Quick Installation Guide - To provide brief product information and quick installation and wireless setting.

Software CD – Free bundled web-based 9 channels IP Surveillance Software, EZvuu wizard, User Manual and Quick Installation Guide.

Ethernet cable – Assist to setup your IP Camera.

Mounting Bracket – There are three components including lock ring, brace, and base plate to compose a bracket and three applied screws to fix the base plate to a flat surface. (horizontal or vertical)

Adaptor - 12V DC, max 12W

Table of Contents

Product Overview

Hardware Installation

EZvuu

Easy Access

Live View

Setting

Appendix

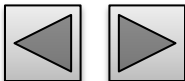

Physical Description

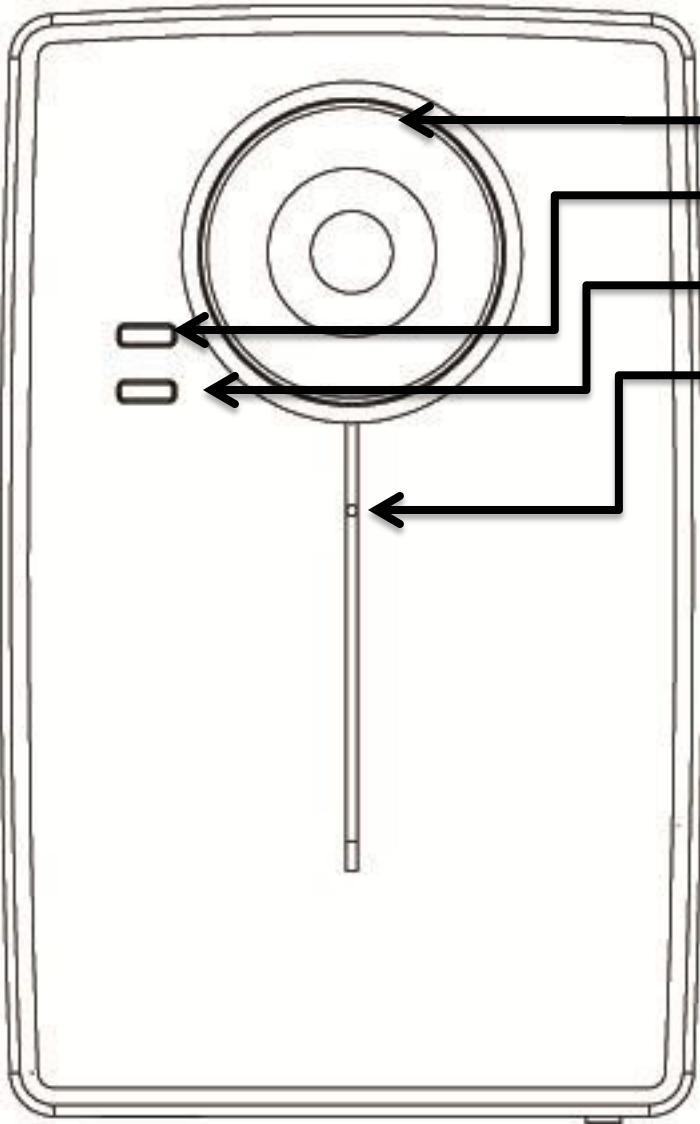

Front View

- Focus Adjustment Ring** - Adjust focus manually to achieve the best image quality.
- Power LED indicator** - Power LED will light up after the IP Camera completed the boot process.
- Network LED indicator** - Network LED will light up after the IP Camera connected with network.
- Built-In Microphone** - Built-In Microphone for Two-way Audio.

Table of Contents

Product Overview

Hardware Installation

EZvuu

Easy Access

Live View

Setting

Appendix

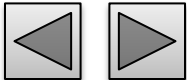

POWER LED	
Steady Red	Boot up process
Steady Blue	Boot up complete
Steady Blue → Flash Purple	Push WPS button and ready for connecting wireless router/AP
Flash Purple → Steady Blue	WPS configuration finished
Flash Purple → Steady Red 30 Secs	WPS configuration failed
Steady Blue → Unlit	Push reset button and then reset
Steady Blue → Unlit → Steady Blue	Push reset button for at least 5 secs and then reset to default
Steady Blue → Flash Purple	Firmware upgrade
ETHERNET/WIRELESS LED	
Flashing blue	Wired packets transmission
Unlit	No transmission

Table of Contents

Product Overview

Hardware Installation

EZvuu

Easy Access

Live View

Setting

Appendix

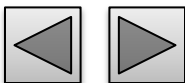

Bottom View

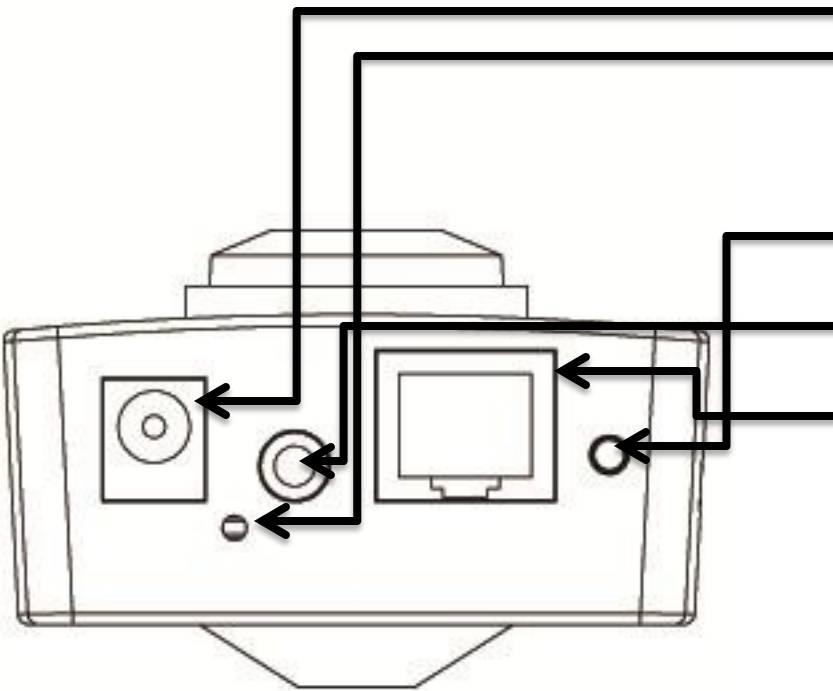

Power Connector - For connection of 12V DC input.

Reset – When the device is empowered, press the Reset Button to reboot the device, or hold the Reset Button for 10 seconds to set the device settings back to factory default.

WPS – Click to easily connect to your router equipped with WPS. (Only IP1050)

Audio Out (Speaker) - To support audio out with earphones or speakers

Network Connector - For connection to the Ethernet via RJ-45 standard

Table of Contents

Product Overview

Hardware Installation

EZvuu

Easy Access

Live View

Setting

Appendix

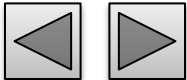

Mounting and Cable Connecting

Wall and Ceiling Mounting

1. Use the 3 supplied screws to fix the base plate to a flat surface.
2. Loosen the lock ring to adjust the desired angle of the camera.
3. Tighten the lock ring.

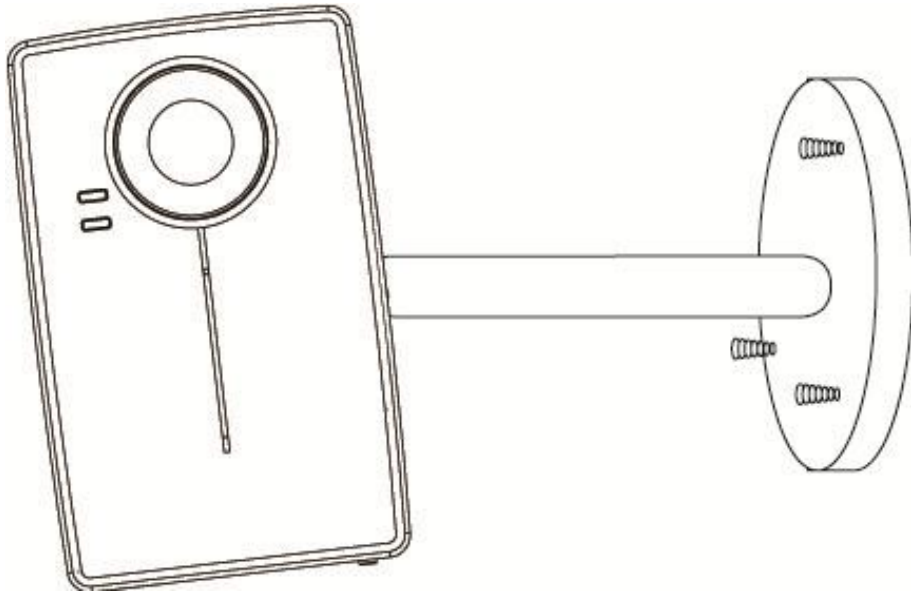

Power and Ethernet Connecting

1. Use a standard RJ-45 network cable to connect the IP Camera to the Network connection
2. Connect power adaptor to the IP Camera.

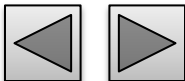
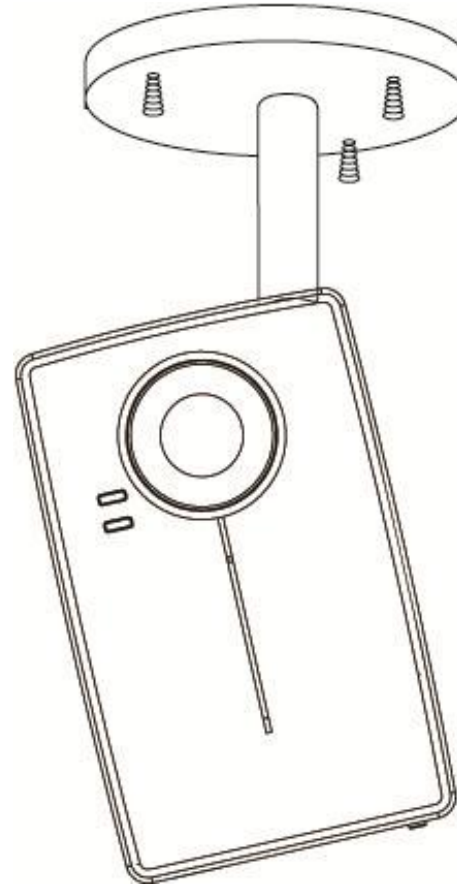

Table of Contents

Product Overview

Hardware Installation

EZvuu

Easy Access

Live View

Setting

Appendix

Live View



Client Setting



Camera Console



Remote Playback



Remote Record



OSD Toolbar



Table of Contents

Product Overview

Hardware Installation

EZvuu

Easy Access

Live View

Setting

Appendix

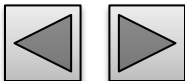



Table of Contents

Product Overview

Hardware Installation

EZvuu

Easy Access

Live View

Setting

Appendix

1. Screen Division

Allocate the sub-screen display by clicking on the desired layout icon.

1 channel; 4 channel; 6 channel; 9 channel

2. Logout

Click to logout EZvuu

3. Camera Layout

Assign cameras to camera layout by drag and drop. You can double click on a particular view to extend display to full screen. Double click on the screen again to regain previous camera layout.

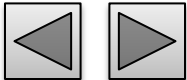



Table of Contents

Product Overview

Hardware Installation

EZvuu

Easy Access

Live View

Setting

Appendix

4. Camera Group

Click to see which cameras in this group. The following is the meaning of each icon:

- No owner cameras group. It will flash when there's new no owner camera.
- Your cameras group
- Friends camera group

5. Add Camera

Click to add no owner camera to your account.

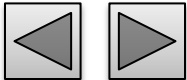



Table of Contents

Product Overview

Hardware Installation

EZvuu

Easy Access

Live View

Setting

Appendix

6. Screen Position

Display this camera in which sub-screen. Blue means live view, green means playback, orange means remote playback and red means record.

7. Camera Status

Click to display control panel. The following is the meaning of each icon:

- Camera unavailable
- Camera available
- Unknown camera

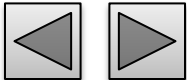

Client Setting

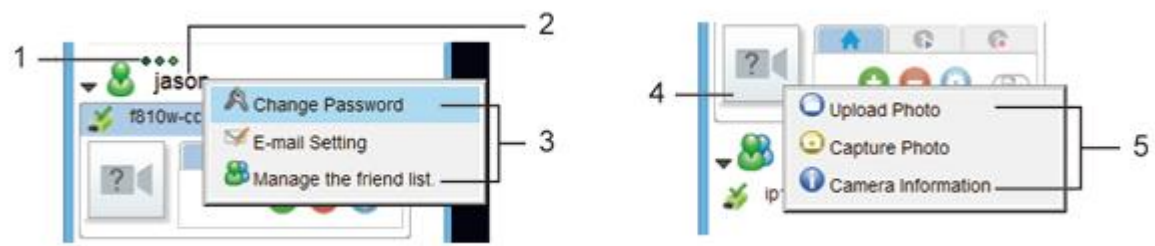

1. Online Users

Display online users of your account. The limitation is simultaneously 5 users online.

2. Account Name

Display the name of your EZvuu account.

3. Account Setting

Right Click your account and it will display your account setting including: "Change Password", "E-mail Setting" and "Manage the friend list".

Select to change the password of your EZvuu account.

Select to change registered E-mail of your EZvuu account.

Select to add a friend to your friend list of delete a friend from your friend list.

4. Portrait

Display the portrait of this camera.

5. Portrait Setting

Click portrait to setup a portrait of this camera. You can upload photo from your local PC by selecting or select to snapshot as the portrait. Select to see your device name and nickname.

Table of Contents

Product Overview

Hardware Installation

EZvuu

Easy Access

Live View

Setting

Appendix

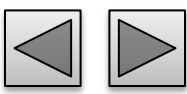

Camera Console

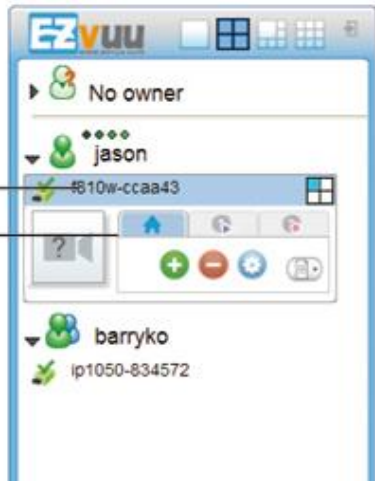

1. Camera Name

Display nick name of this camera. You can right click to change the nick name.

2. Camera Console

Click to display camera console.

Click to share this camera to your friends.

Click to remove this camera from your camera list.

Click into setting page of this camera.

Click to display playback control including:

- Stop playing this channel
- Start recording to your local PC. The icon will display when the video is on recording.
- Enter the setting page of this camera
- Select to enable microphone. The icon will display when microphone is enabled.
- Select to take a snapshot from this camera.

Table of Contents

Product Overview

Hardware Installation

EZvuu

Easy Access

Live View

Setting

Appendix

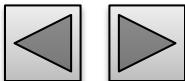

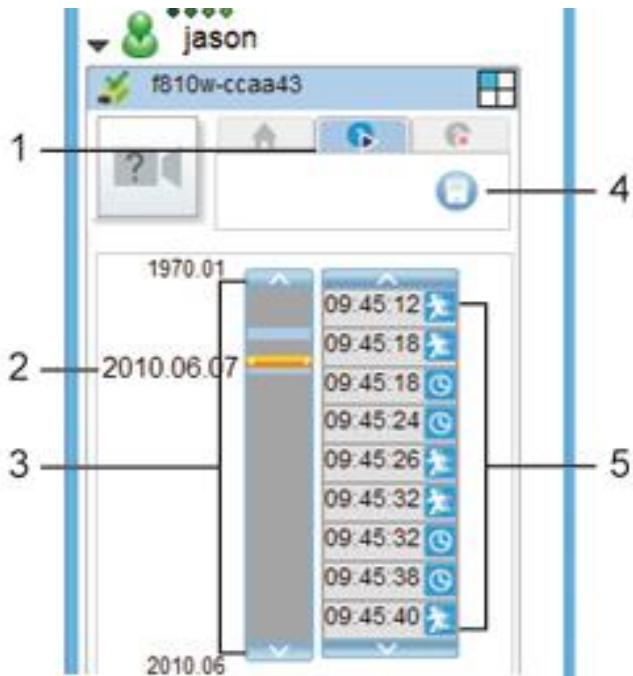

Remote Playback



1. Remote Playback

Click to display remote playback console.

2. Time Selector

Using the date selector, it is possible to jump straight to recordings from a specific point in time. You can drag  to the blue background of timeline browser to remote playback. You also can click  and  to scroll monthly. If there's no any record in last month or next month, it would jump to the month with record.



3. Timeline Browser

Display an overview of periods with recordings from this camera.

4. Remote Recording Storage Setting

Click to setup your NAS.

5. Events

Display the events and recording time of the recording date you select. You can click  and  to scroll events. The following is the meaning of each icon:



-  Motion detection
-  Periodical recording

Table of Contents

Product Overview

Hardware Installation

EZvuu

Easy Access

Live View

Setting

Appendix

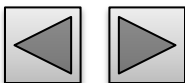

Remote Record

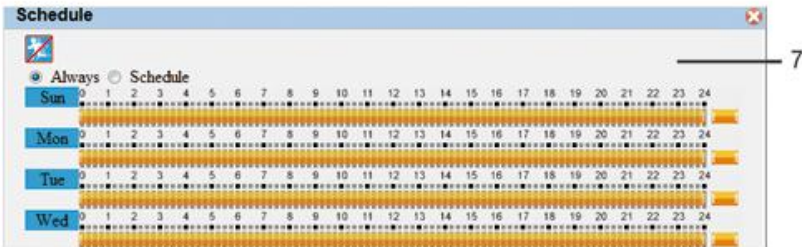
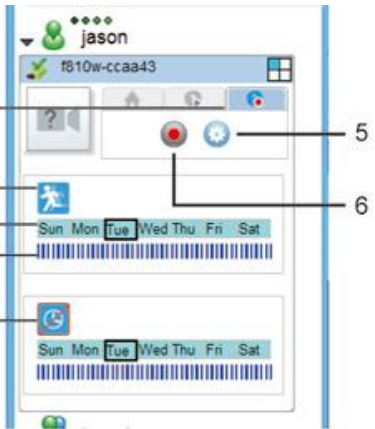

1. Remote Record

Click to display remote record console.

2. Motion Detection Status

Display motion detection status. You can click this icon to setup motion detection schedule. The following is the meaning of each icon: Motion detection enabled; Motion detection disabled.

3. Record Schedule

Display the scheduled recording time of each day. The black rectangle means what day today is of the camera. The blue timeline represents the recording time of today.

4. Periodical Recording Status

Display periodical recording status. You can click this icon to setup periodical recording schedule. The following is the meaning of each icon: Periodical recording enabled; Periodical recording disabled

5. Remote Recording Storage Setting

Click to setup your NAS.

6. Remote Manual Record

Click to enable remote record.

7. Schedules

Click and to enable or disable motion detection and periodical recording. Select "Always" to schedule full-time recording. Select "Schedule" to schedule preferred recording time. You can drag at most to the timeline and stretch the time bars to fit your demand.

Table of Contents

Product Overview

Hardware Installation

EZvue

Easy Access

Live View

Setting

Appendix

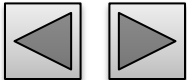

OSD Toolbar

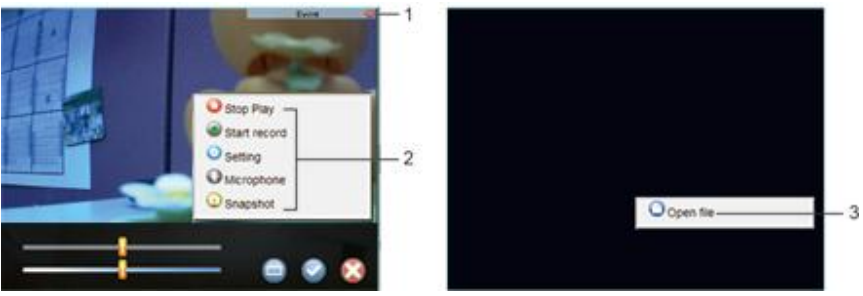

1. OSD Toolbar

Display OSD toolbar when you move your mouse on the view screen. You can click and to pull up and down the events list. The events list will flash when there is a new event. In the events OSD, it will show the recording date & time and what event triggers. You can also click and to scroll the event list. Click , and to setup the 3 motion detection zones. In the motion detection setting mode, you can click to enable/disable motion detection zone. The upper slider is threshold slider which means the extent of the alarm triggered. The below slider is sensitivity slider which means how often the sensor will scan the image different. The higher sensitivity it is and the more frequently it scans. After setup, you can click to apply all setting and click to leave motion detection mode.

2. Playback Controls

Right click the screen division and there are 5 video operations including:

- Stop playing this channel
- Start recording to your local PC. The icon will display When the video is on recording.
- Enter the setting page of this camera
- Select to enable microphone. The icon will display when microphone is enabled.
- Select to take a snapshot from this camera.

3. View Local Archived Recordings

Right click the blank screen division and click to playback local videos.

Table of Contents

Product Overview

Hardware Installation

EZvuu

Easy Access

Live View

Setting

Appendix

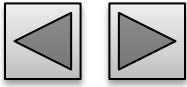

Easy Access

Web Browsers

Windows Web Browsers



Mac Safari



Mobile Phone Viewing

Using IP Camera Via iPhone



3G Mobile Phone Streaming



2.5G Mobile Phone WAP



2.5G Mobile Phone Browser



Windows Live Messenger



Table of Contents

Product Overview

Hardware Installation

EZvuu

Easy Access

Live View

Setting

Appendix

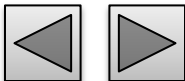

Web Browsers

Windows Web Browsers

1. Start your web browser, and enter the IP address or host name of the IP camera in the Location / Address field of your browser.

Note

If you only want to view the video without setting page, enter "<http://<IP>/index2.htm>" as your web URL.

2. Use the default account "admin" and default password "admin".

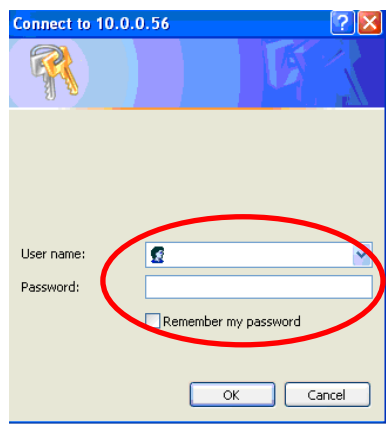

Note

The default user name "admin" and the password are set at the factory for the administrator.

3. The monitor image will be displayed in your browser. In the far left side of main configuration are Setting, Client Setting, and Image Setup.

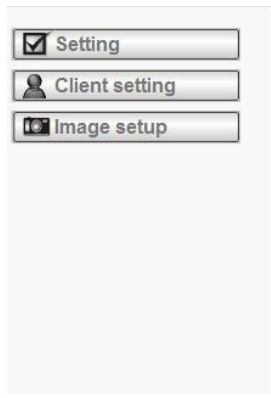

Table of Contents

Product Overview

Hardware Installation

EZvuu

Easy Access

Live View

Setting

Appendix

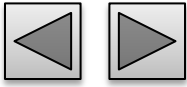

Web Browsers

Mac Safari

1. Click the Safari icon, and enter the IP address of the IP camera in the Location / Address field of your browser.

Note

If you only want to view the video without setting page, enter "<http://<IP>/index2.htm>" as your web URL.



2. Use the default account "admin" and default password "admin".

Note

The default user name "admin" and the password are set at the factory for the administrator



Table of Contents

Product Overview

Hardware Installation

EZvuu

Easy Access

Live View

Setting

Appendix

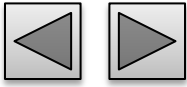

Web Browsers

3. The monitor image will be displayed in your browser. In the far left side of main configuration are Setting, Client Setting, and Image Setup.

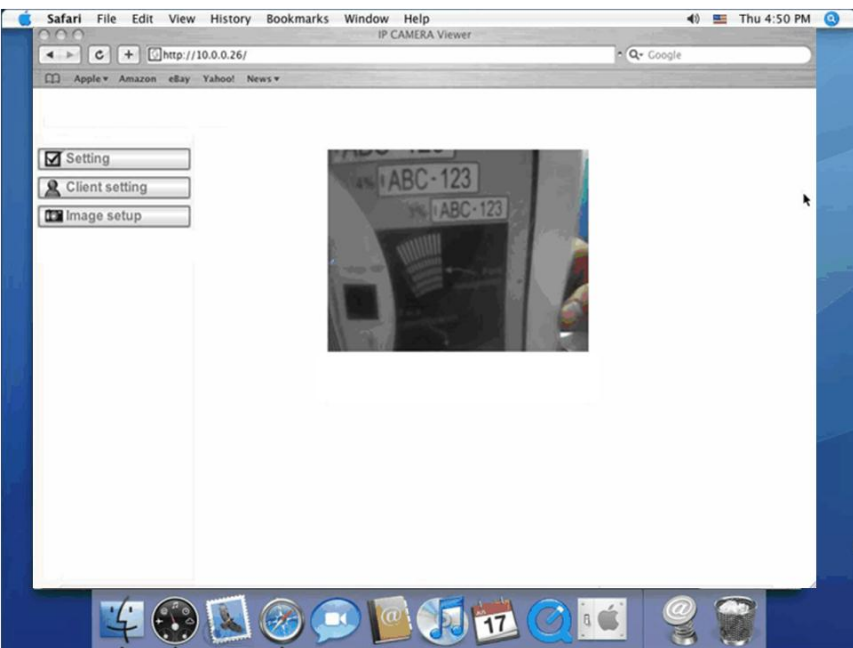

Table of Contents

Product Overview

Hardware Installation

EZvuu

Easy Access

Live View

Setting

Appendix

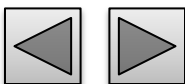

Mobile Phone Viewing

Using IP Camera Via iPhone

1. Select Safari function



2. Enter IP address in your web link.



3. Type name and password. Default value is admin / admin. Then click Login In

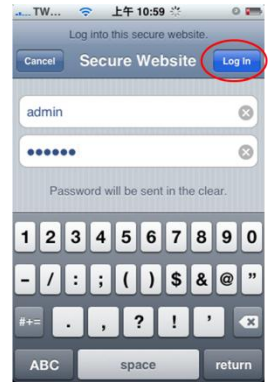

4. Live view will show up in the middle of screen.

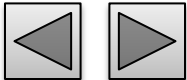

Table of Contents

Product Overview

Hardware Installation

EZvuu

Easy Access

Live View

Setting

Appendix

Mobile Phone Viewing

3G Mobile Phone Streaming

For 3G mobile phone viewing, type “[rtsp://<IP>:<PORT>/video.3gp](#)” into your 3G Streaming Link. <IP> is the Public IP address of your IP camera; <PORT> is the RTSP port of your IP camera (Default value is 554.) Example:
[rtsp://100.10.10.1:554/video.3gp](#)

Note

You can also use RTSP clients (RealPlayer, VLC, QuickTime Player...etc.) to view RTSP streaming, just type in “[rtsp://<IP>:<PORT>/video.3gp](#)” as the Player URL

2.5G Mobile Phone WAP

For 2.5G mobile phone viewing, type “[http://<IP>/mobile.wml](#)” into your 2.5G WAP Browser. <IP> is the Public IP address of your IP camera.

2.5G Mobile Phone Browser

For 2.5G mobile phone viewing, type “[http://<IP>/mobile.wml](#)” into your 2.5G WAP Browser. <IP> is the Public IP address of your IP camera.

Table of Contents

Product Overview

Hardware Installation

EZvuu

Easy Access

Live View

Setting

Appendix

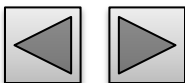

Windows Live Messenger

1. Apply for a new MSN account for your Device

2. Type login account and password

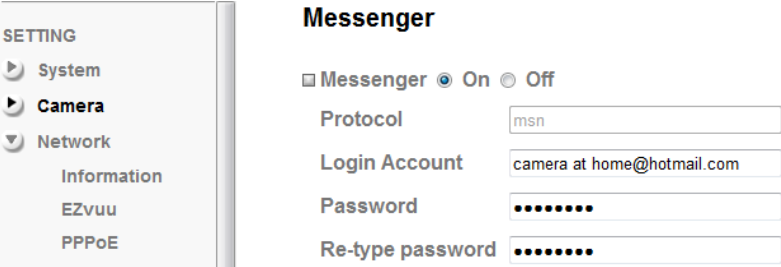

3. Set the following settings

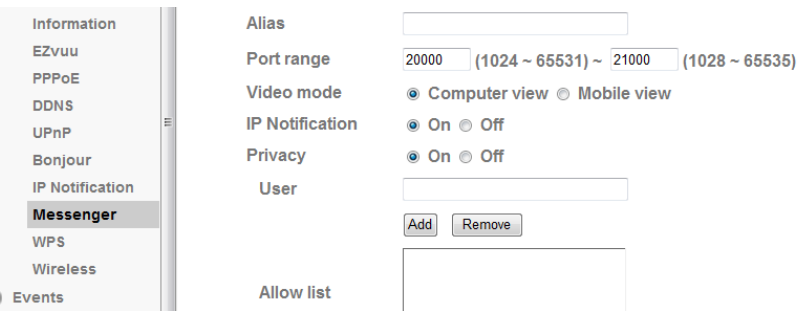

4. You will get IP information automatically



5. Click  to live viewing by Windows Live Messenger

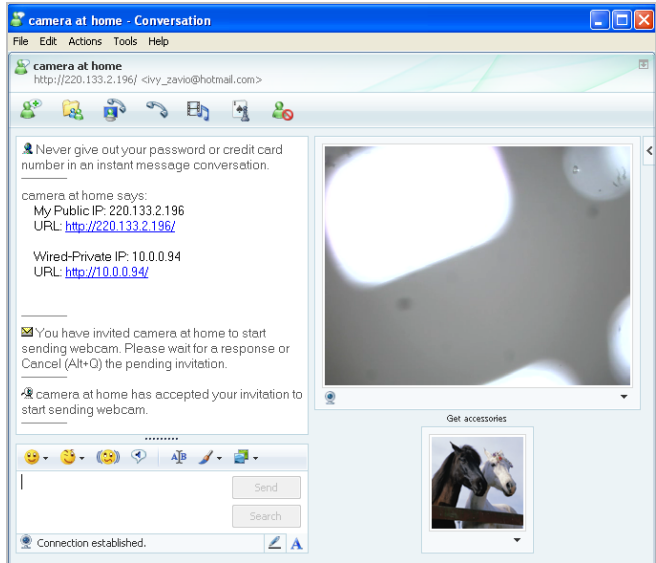

Table of Contents

Product Overview

Hardware Installation

EZvuu

Easy Access

Live View

Setting

Appendix

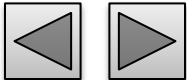





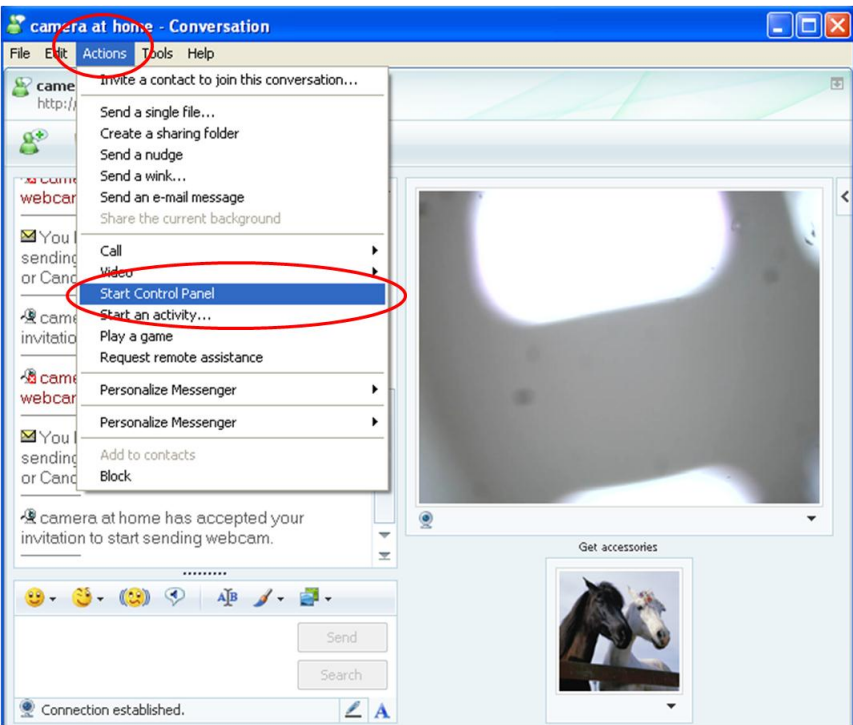

Windows Live Messenger

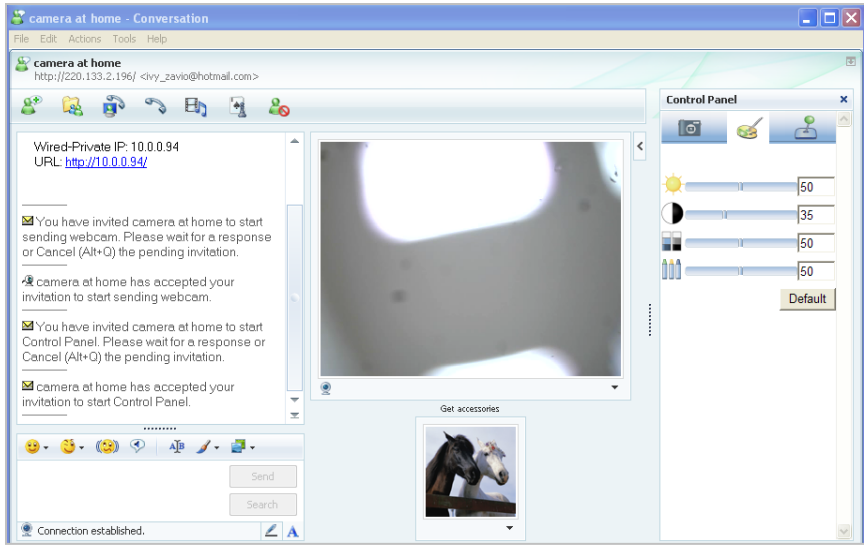
6. Click Action button and choose Start control panel



7. Click icons to snapshot or optimize image

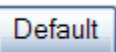

-  **Snapshot**
-  **Image Setup**
-  **Brightness**
-  **Contrast**
-  **Saturation**
-  **Hue**
-  **Default** **Default Image Settings**

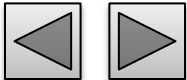

Table of Contents

Product Overview

Hardware Installation

EZvuu

Easy Access

Live View

Setting

Appendix

Live View

Live View Control Panel



Setting



Client Setting



Image Setup



Table of Contents

Product Overview

Hardware Installation

EZvuu

Easy Access

Live View

Setting

Appendix

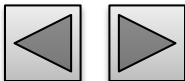

Live View Control Panel

- Setting
- Client setting
- Image setup

Full Screen

Snapshot

Live View

Video Play

Audio In

Audio Out

Zoom In/Out

The central video player shows a live feed of a cluttered room. The interface includes a top bar with 'Live View' text and two icons (a camera and a square). The bottom bar contains several icons: a play/pause button (circled in red), a microphone icon, a speaker icon, and a zoom icon. Red arrows point from text labels to these icons. A 'Snapshot' arrow points to the camera icon in the top bar, and a 'Full Screen' arrow points to the square icon in the top bar.

- Table of Contents
- Product Overview
- Hardware Installation
- EZvuu
- Easy Access
- Live View**
- Setting
- Appendix

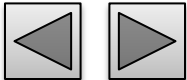

Setting

Setting

This function is only for the Administrator. Click this button to get into the setting page.

- Setting
- Client setting
- Image setup



There are four sub-folders including System, Camera, Network, and Events and a Question mark inside. Click question mark will pop-up a new window and you can get answers online without user manual.

- Home

- SETTING
- System
- Camera
- Network
- Events



Welcome to Camera Settings Page

HELP is an online help and support. It provide solutions immediately.

HELP

- ▼ System
 - [Information](#)
 - [Day/Time](#)
 - [Account](#)
 - [System Log](#)
 - [Initialize](#)
- ▼ Camera
 - [General](#)
 - [MPEG4 – Computer View](#)
 - [MPEG4 – Mobile View](#)
 - [MJPEG](#)
- ▼ Network
 - [Information](#)

Table of Contents

Product Overview

Hardware Installation

EZvuu

Easy Access

Live View

Setting

Appendix

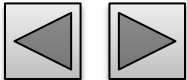

 **Setting**

 **Client setting**

Mode ▼

View size ▼

Video buffer ▼

 **Image setup**

Client Setting

This function is only for the administrator and client.

Mode

Click the pull-down box to choose between MPEG-4 MJPEG, and JPEG video compression mode. MJPEG streaming is unavailable if RTSP mode is "On."

Video Size

Select the desired display image resolution to 640X480 or 320X240.

Video Buffer

Turn the Video Buffer function ON / OFF. The Video Buffer function makes the streaming more smoothly in unsteady network environment, but might cause a little delay in live viewing.

Table of Contents

Product Overview

Hardware Installation

EZvuu

Easy Access

Live View

Setting

Appendix

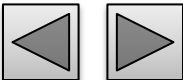



Setting



Client setting



Image setup

Brightness



45

Contrast



40

Saturation



70

Hue



50

Default

Brightness

The higher value the brightness is, the brighter the image is.

Contrast

The contrast is a measure of a display system, defined as the ratio of white to black that the system is capable of producing. The higher value the contrast is, the more delicate of color you can have.

Saturation

The saturation of a color is determined by a combination of light intensity and how much it is distributed across the spectrum of different wavelengths. The higher value the saturation is, the more colorful the image will be.

Hue

Hue is one of the three main attributes of perceived color, affected by different wavelength of color. With higher value of hue, color will be much more vivid.

Default

After the adjustment of all setting, you can still click Default to make the setting back to the original setting.

Table of Contents

Product Overview

Hardware Installation

EZvuu

Easy Access

Live View

Setting

Appendix

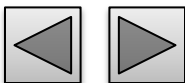

Setting

System

Information

Date/Time

Account

System Log

Initialize

Camera

General

MPEG4

Computer View

Mobile View

MJPEG

Network

Information

EZvuu

PPPoE

DDNS

UPnP

IP Notification

WPS

Wireless

Messenger

Events

FTP Client

SMTP

Network Storage

Motion Detection

Schedule

Help



Table of Contents

Product Overview

Hardware Installation

EZvuu

Easy Access

Live View

Setting

Appendix

Information

The Information page provides the product factory information which includes **Product Name, Firmware Version and Web Version.**

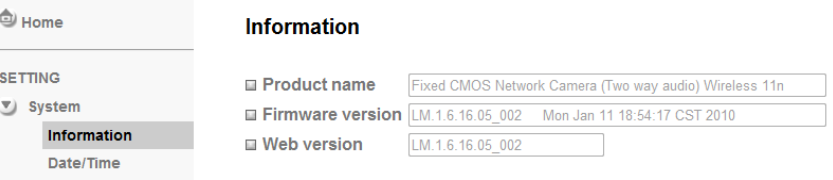

Day/Time

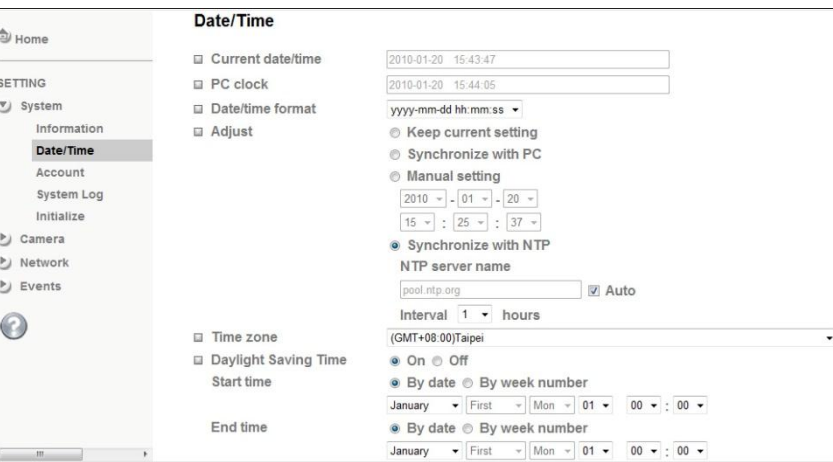

Current date / time

Display the current date and time of this IP Camera.

PC clock

Display the date and time of the monitoring PC clock.

Date / Time format

Pull down box to select different time display formats.

Adjust

Keep current setting

Keep the current date and time of this IP Camera.

Synchronize with PC

Keep the date and time the same PC.

Manual setting

Adjust manually the date and time of this IP Camera.

Synchronize with NTP

Specify the NTP server name and the Refresh Interval to synchronize.

Time Zone

You can select the Time Zone.

Daylight Saving Time

There are two modes to choose for setting up daylight saving time.

By Date

Set the start and end time by select month, day, hour, and minute.

By Week Number

Set the start and end time by select month, week, hour, and minute.

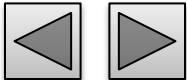
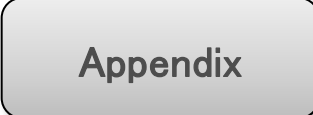
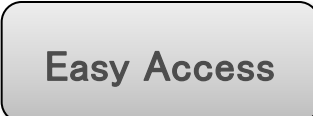
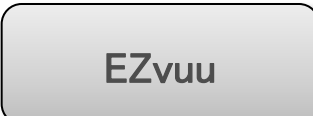
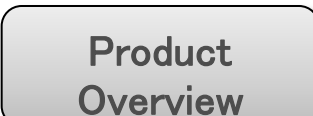

Account

The device fault account and password setting is "admin / admin". That means everyone who knows IP address can access the device including all configuration. It is necessary to assign a password if the device is intended to be accessed by others.

User name

Set a user name between 4-16 characters.

Password

Set a password between 4-16 characters.

Re-type Password

Re-type the password to confirm.

Viewer Mode

Set the user mode among Admin, Operator, and Viewer. Different viewer mode has different limits of authority.

Admin mode

Has all authority of configuration.

Operator mode

View the Live View and Use Control Panel.

Viewer mode

View the Live View only.

Viewer Authentication

Allows any viewer direct access to Live View.

Table of Contents

Product Overview

Hardware Installation

EZvuu

Easy Access

Live View

Setting

Appendix

Home

SETTING

- System
 - Information
 - Date/Time
 - Account**
 - System Log
 - Initialize
- Camera
- Network
- Events

Account

User ID	User name	Password	Re-type Password	Viewer mode
Administrator	admin	*****	*****	Admin
User 1				Admin
User 2				Admin
User 3				Admin
User 4				Admin
User 5				Admin
User 6				Admin
User 7				Admin
User 8				Admin
User 9				Admin

Viewer authentication On Off

OK Cancel

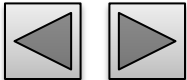

System Log

The System Log function allows users to review any changes and events happened. The system starts logging automatically after started.

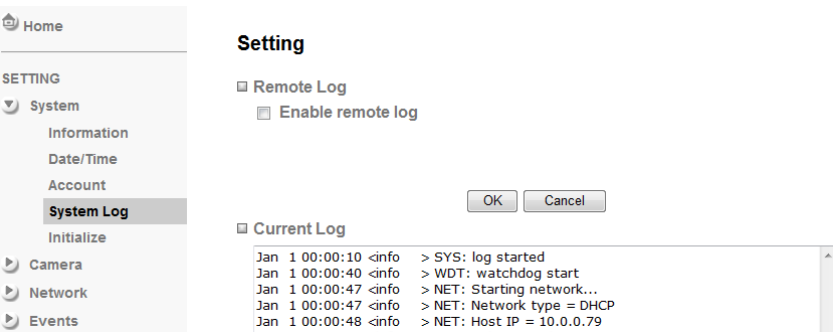

Enable remote log

Enables user to send the log data to a specified log server.

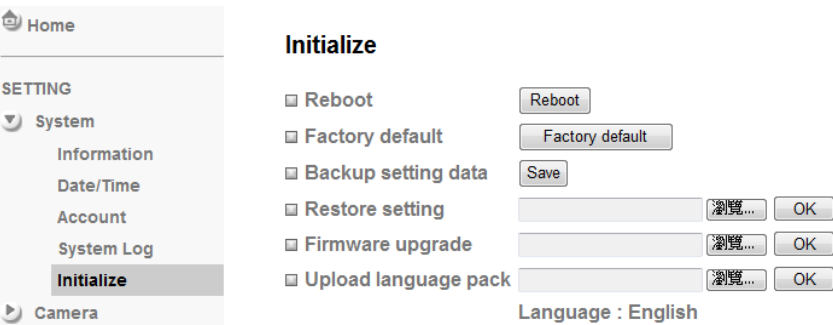

Initialize

Reboot

Reboot this IP Camera and it takes two minutes to reboot this IP Camera.

Factory Default

Reset this IP Camera to the factory default setting.. Don't turn off this IP Camera until the device reboots.

Backup Setting

Backup the setting data of this IP Camera.

Restore Setting

Click "Browse" to restore setting and then restart automatically.

Firmware Update

Click "Browse" to upgrade firmware.

Upload Language Pack

Upgrade the device language pack.

Note

Use only upgrade files that are special for this IP Camera. Otherwise problems may occur. Don't turn off the IP Camera power or disconnect the network until the upgrading is completed.

Table of Contents

Product Overview

Hardware Installation

EZvuu

Easy Access

Live View

Setting

Appendix

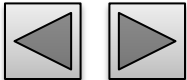

General

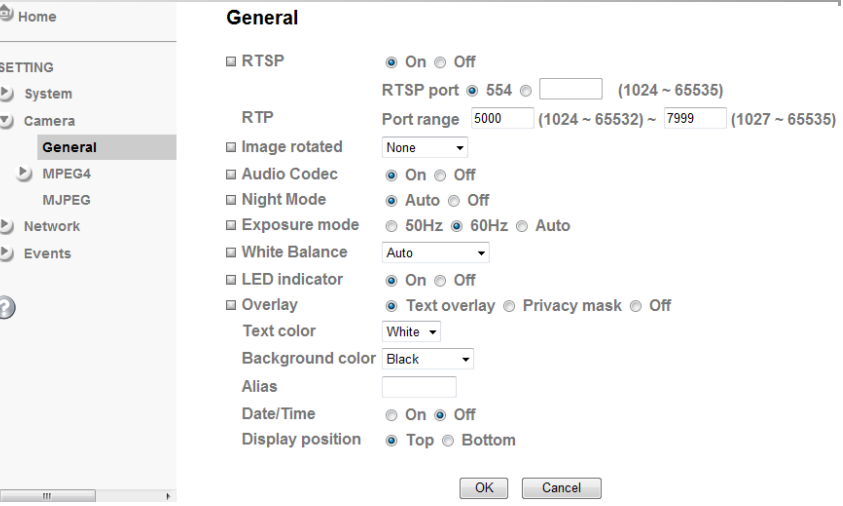

RTSP

Switch RTSP "On" or "Off." The default value is 554.

Image Rotate

You can mirror or flip the display screen.

Audio Codec

If this option is selected On, the microphone will start sound reception.

Night Mode

You can choose Auto / Off. **If you choose Auto option**, the camera will adjust automatically to perform well when the environment is dark.

Exposure Mode

You can choose the environment among 50 Hz, 60 Hz , and Outdoor.

White Balance

You can choose the white balance to Auto, Florescent, Incandescent and Black & White.

LED Indicator

Turn on/off the LED indicator.

Overlay

Text Overlay

You can see some information on the display screen which includes Date / Time and user-defined text. Also, you can change the background color.

Privacy Mask

You can cover a specific area of the video image.

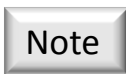

RTSP (Real Time Streaming Protocol) is a protocol for use in streaming media system which allows clients to remotely control a streaming video server. RTSP is supported by most of the media clients such as Real Player, QuickTime and VLC...etc.

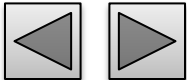
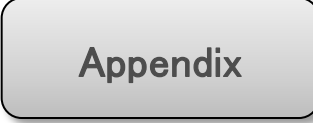
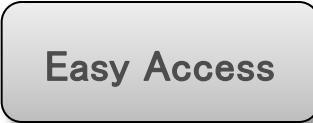
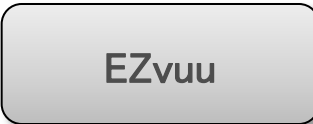
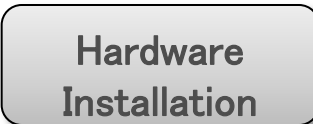

MPEG4 – computer view

If **RTSP** is **ON**, the option of Viewer Authentication & Multicast Streaming will appear.

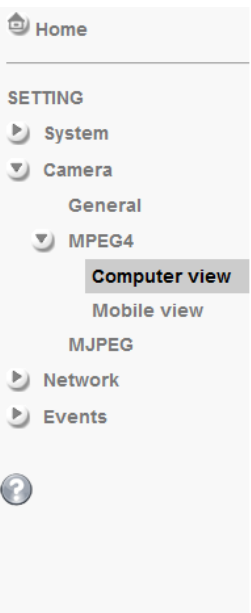

Computer view

- Viewer authentication On Off
- Multicast streaming On Off
 - Multicast address
 - Video port Auto 6000 (1024 ~ 65535)
 - Audio port Auto 7000 (1024 ~ 65535)
 - Time-To-Live (1 to 255)
- Image Size
- Frame rate fps
- Quality
 - Auto
 - Fixed quality
 - Fixed bitrate kbps

Viewer Authentication

If the viewer authentication is On, the users will be requested to key-in username and password when viewing through RTSP.

Multicast Streaming (If it's on)

Multicast Address

Specify the multicast server address.

Video / Audio Port

Specify the transmission port number of the video data.

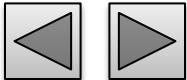

Time to Live

Set the maximum TTL that multicast can pass through.

Image Size

Specify the image size when the network camera transmits

Frame Rate

Set the frame rate of the MPEG4 image.

Quality

Auto

The quality and bitrate will be adjusted automatically according to the frame rate.

Fixed Quality

You can select the value of quality.

Fixed Bitrate

Set the bitrate of MPEG4 image transmission for a line.

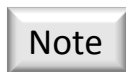

Concerning how to select the suitable image quality for Fixed Quality or Fixed Bitrate, please refer to APPENDIX / A. Frame-rate & Bitrate Table.

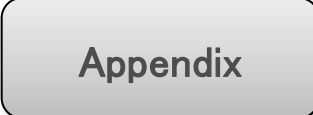
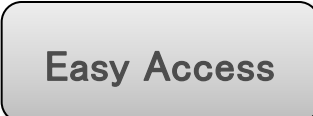
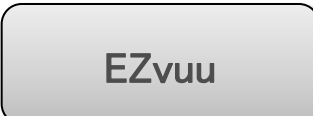
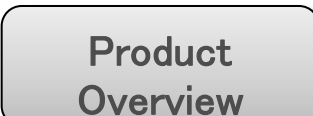
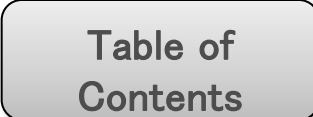

Camera

MPEG4 – mobile view

If **RTSP** is **ON**, the option of Viewer Authentication & Multicast Streaming will appear.

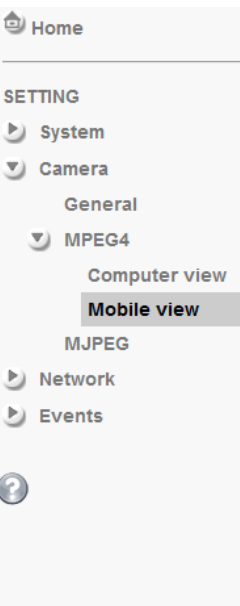

Mobile view

- Viewer authentication On Off
- Multicast streaming On Off
 - Multicast address
 - Video port Auto 10000 (1024 ~ 65535)
 - Audio port Auto 11000 (1024 ~ 65535)
 - Time-To-Live (1 to 255)
- Image Size
- Frame rate fps
- Quality
 - Auto
 - Fixed quality
 - Fixed bitrate kbps

Viewer Authentication

If the viewer authentication is On, the users will be requested to key-in username and password when viewing through RTSP.

Multicast Streaming (If it's on)

Multicast Address

Specify the multicast server address.

Video / Audio Port

Specify the transmission port number of the video data.

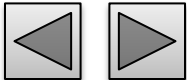

Time to Live

Set the maximum TTL that multicast can pass through.

Image Size

Specify the image size when the network camera transmits

Frame Rate

Set the frame rate of the MPEG4 image.

Quality

Auto

The quality and bitrate will be adjusted automatically according to the frame rate.

Fixed Quality

You can select the value of quality.

Fixed Bitrate

Set the bitrate of MPEG4 image transmission for a line.



Concerning how to select the suitable image quality for Fixed Quality or Fixed Bitrate, please refer to APPENDIX / A. Frame-rate & Bitrate Table.

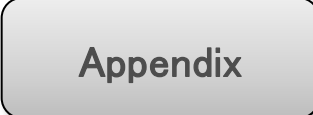
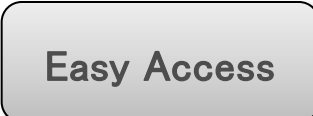
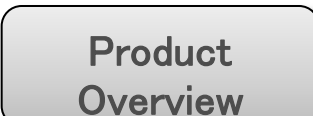

MJPEG

If **RTSP** is **OFF**, the option of Image Size & Frame Rate & Quality will appear.

Home

SETTING

- System
- Camera
 - General
 - MPEG4
 - MJPEG**
 - Network
 - Events

?

MJPEG

- Image Size
- Frame rate fps
- Quality
 - Auto
 - Fixed quality

OK Cancel

Image Size

Specify the image size when the network camera transmits

Frame Rate

Set the frame rate of the MJPEG image.

Quality

Auto

The quality and bitrate will be adjusted automatically according to the frame rate.

Fixed Quality

You can select the value of quality.

Fixed Bitrate

Set the bitrate of MPEG4 image transmission for a line.

Note

Concerning how to select the suitable image quality for Fixed Quality or Fixed Bitrate, please refer to APPENDIX / A. Frame-rate & Bitrate Table.

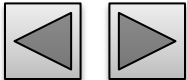

Table of Contents

Product Overview

Hardware Installation

EZvuu

Easy Access

Live View

Setting

Appendix

Information

Display the MAC address of the device.

- Home
- SETTING
- System
- Camera
- Network
 - Information**
 - EZvuu
 - PPPoE
 - DDNS
 - UPnP
 - IP Notification
 - WPS
 - Wireless
 - Messenger
 - Events

Information

MAC address

Obtain an IP address automatically (DHCP)
 Use the following IP address

IP address
 Subnet mask
 Default gateway

Obtain DNS server address automatically
 Use the following DNS server address

Primary DNS server
 Secondary DNS server

HTTP port number 80 (1024 to 65535)

Obtain an IP address automatically (DHCP)

Select this while the IP address is assigned by the DHCP server.

Obtain DNS server address automatically

Select this to obtain the address of DNS server automatically.

Use the following IP address

Select this when the fixed IP address is set.

IP address

Enter the IP address of the device.

Subnet mask

Enter the subnet mask.

Default gateway

Enter the default gateway.

Use the following DNS server address

Select this when you set the fixed address as the IP address of DNS server.

Primary DNS server

Enter the IP address of the primary DNS server.

Secondary DNS server

Enter the IP address of the secondary DNS server, if necessary.

HTTP port number

Select **80** (recommend) or enter a port number between 1024 and 65535.

Table of Contents

Product Overview

Hardware Installation

EZvuu

Easy Access

Live View

Setting

Appendix

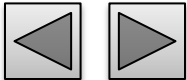

Network

EZvuu

EZvuu, also known as zero-configuration networking, enables automatic to find your devices on IP networks. EZvuu uses Windows Live Messenger protocols to allow devices to automatically discovered without the need to enter IP addresses or configure DNS servers.

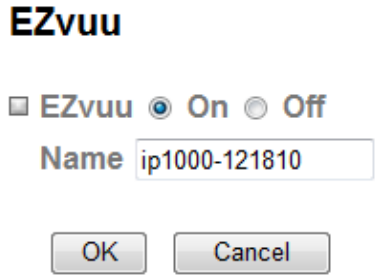
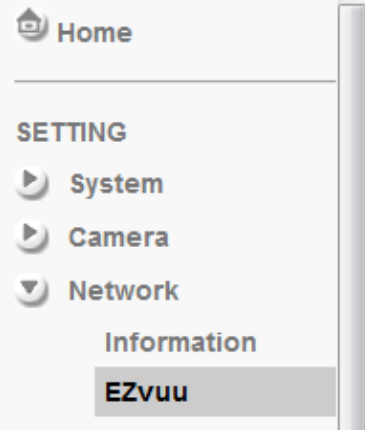

Name

Show your device name on EZvuu.

Table of Contents

Product Overview

Hardware Installation

EZvuu

Easy Access

Live View

Setting

Appendix

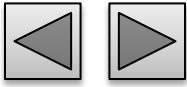

PPPoE

If your ISP provides Dynamic IP with authentication by username and password, type all PPPoE information in this part. When you use the PPPoE function, you need to turn on the DDNS or IP Notification function at same time.

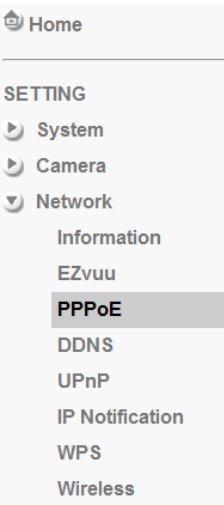

PPPoE

PPPoE On Off

IP address

User ID

Password

Re-type password

Obtain DNS server address automatically

Use the following DNS server address

Primary DNS server

Secondary DNS server

Note

1. The IP Camera needs to be rebooted after it finishes changing the network completely.
2. The IP Camera with Intelligent IP Installer can't be founded after turning on the PPPoE and reboot.

IP Address

The IP address obtained at the PPPoE connecting with network.

User ID

Enter the user ID for authentication necessary for PPPoE connections.

Password

Enter the password for authentication necessary for PPPoE connections.

Re-type Password

Re-type the password to confirm.

Obtain DNS server address automatically

Select this to obtain the address of DNS server automatically.

Use the following DNS server address

Select this when you set the fixed address as the IP address of DNS server.

Primary DNS server

Enter the IP address of the primary DNS server.

Secondary DNS server

Enter the IP address of the secondary DNS server.

Table of Contents

Product Overview

Hardware Installation

EZvuu

Easy Access

Live View

Setting

Appendix

