

iD.FREE / iD.TRI
**USER
GUIDE**



SIGMA[®]
GERMANY

www.sigmasport.com

Contents / Verpackungsinhalt / Contenido del paquete / Contenuto della confezione / Contenu de l'emballage / Verpakingsinhoud / Obsah balení / Zawartość opakowania



ID.FREE / ID.TRI

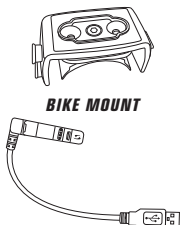

**BIKE MOUNT
CHARGER / DATA CABLE**

**OPTIONAL: / OPTIONAL: / OPTIONAL: / OPTIONAL: / OPTIONAL: / OPTIONAL: /
OPTIONAL: / OPTIONAL: /**

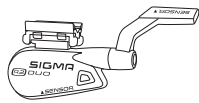

R2 DUO CAD+SPEED



**R1 DUO COMFORTX+
HEARTRATE**



Button functions / Tastenbelegung / Funciones de las teclas / Assegnazione pulsanti / Affectation des touches / Knoppenfuncties / Obsazení tlačítek / Funkcje przycisków



- | | | |
|--|--|--|
| | Start / OK
Workout (iD.TRI): nächste Phase
Competition (iD.TRI): Wechselzone
Training: Lap
Start / OK
Workout (iD.TRI): nächste Phase
Competition (iD.TRI): Wechselzone
Training: Lap
Start / OK
Workout (iD.TRI): nächste Phase
Competition (iD.TRI): Wechselzone
Training: Lap
Start / OK
Workout (iD.TRI): nächste Phase
Competition (iD.TRI): Wechselzone
Training: Lap | Start / OK
Workout (iD.TRI): nächste Phase
Competition (iD.TRI): Wechselzone
Training: Lap
Start / OK
Workout (iD.TRI): nächste Phase
Competition (iD.TRI): Wechselzone
Training: Lap
Start / OK
Workout (iD.TRI): nächste Phase
Competition (iD.TRI): Wechselzone
Training: Lap
Start / OK
Workout (iD.TRI): nächste Phase
Competition (iD.TRI): Wechselzone
Training: Lap |
|--|--|--|

- Stop / Back / Stop / Zurück / Stop / Zurück / Stop / Zurück /
Stop / Zurück / Stop / Zurück / Stop / Zurück / Stop / Zurück

- + / next / vor / vor / vor / vor / vor / vor / vor / vor
long press during training: quick menu / langer Druck im Training:
Schnellmenu / langer Druck im Training: Schnellmenu / langer Druck
im Training: Schnellmenu / langer Druck im Training: Schnellmenu /
langer Druck im Training: Schnellmenu / langer Druck im Training:
Schnellmenu / langer Druck im Training: Schnellmenu /

- / previous / zurück / zurück / zurück / zurück / zurück / zurück /
zurück / zurück

- + Backlight / Hintergrundbeleuchtung /
Hintergrundbeleuchtung / Hintergrundbeleuchtung /
Hintergrundbeleuchtung / Hintergrundbeleuchtung /
Hintergrundbeleuchtung / Hintergrundbeleuchtung

**Training session / Training durchführen /
 Training durchführen / Training durchführen /
 Training durchführen / Training durchführen /
 Training durchführen / Training durchführen**

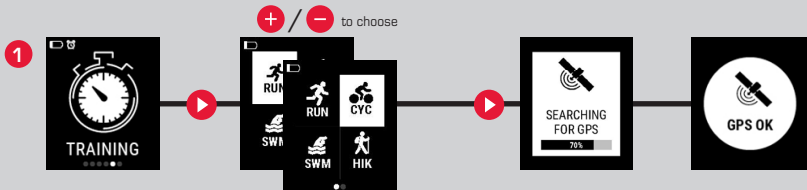

Quickmenu:



Settings like: Auto Pause, GPS, Heartrate etc. can be set here.
 Hier können Daten wie:
 Auto Pause, GPS, Herzfrequenz etc.
 an bzw. ausgeschaltet werden.
 Hier können Daten wie:
 Auto Pause, GPS, Herzfrequenz etc.
 an bzw. ausgeschaltet werden.
 Hier können Daten wie:
 Auto Pause, GPS, Herzfrequenz etc.
 an bzw. ausgeschaltet werden.

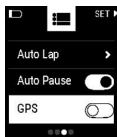

Auto Pause, GPS, Herzfrequenz etc.
 an bzw. ausgeschaltet werden.
 Hier können Daten wie:
 Auto Pause, GPS, Herzfrequenz etc.
 an bzw. ausgeschaltet werden.
 Hier können Daten wie:
 Auto Pause, GPS, Herzfrequenz etc.
 an bzw. ausgeschaltet werden.

<2,2 km/h



Training in Auto Pause/
 Training in Auto Pause/
 Training in Auto Pause/
 Training in Auto Pause/
 Training in Auto Pause/
 Training in Auto Pause/
 Training in Auto Pause



DONE!

Charging / Laden des Geräts / Laden des Geräts
/ Laden des Geräts / Laden des Geräts / Laden des Geräts
/ Laden des Geräts / Laden des Geräts / Laden des Geräts
/ Laden des Geräts / Laden des Geräts

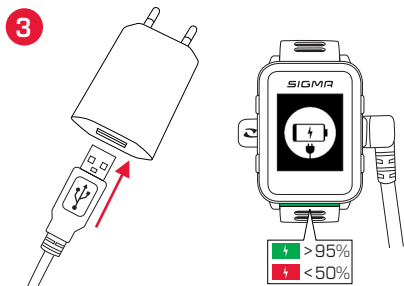
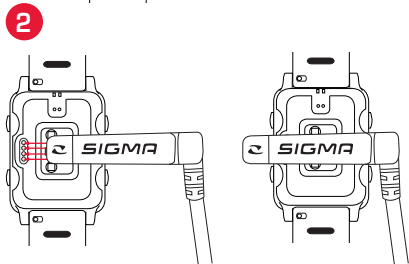
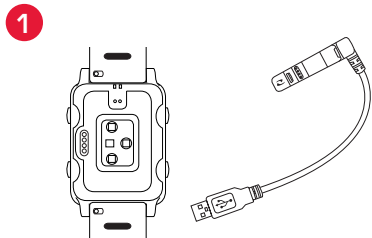

Mounting Instructions / Montagehinweise /
Montagehinweise / Montagehinweise / Montagehinweise
/ Montagehinweise / Montagehinweise / Montagehinweise
/ Montagehinweise /

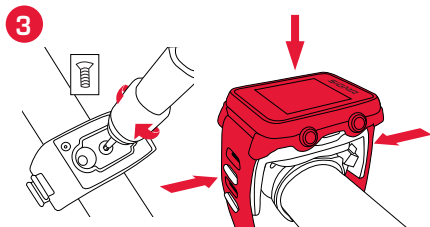
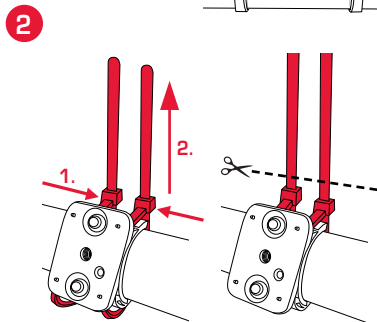
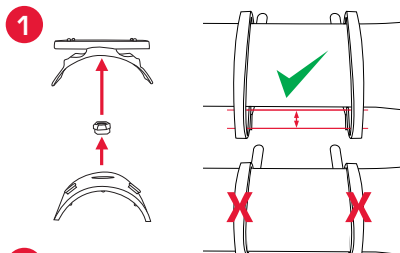

**Sensor assembly / Sensor Montage /
Sensor Montage / Sensor Montage /
Sensor Montage / Sensor Montage /
Sensor Montage / Sensor Montage**

Only included in the iD.TRI Set / Nur im Komplettsset iD.TRI enthalten: / Nur im Komplettsset iD.TRI enthalten: / Nur im Komplettsset iD.TRI enthalten: / Nur im Komplettsset iD.TRI enthalten: / Nur im Komplettsset iD.TRI enthalten: / Nur im Komplettsset iD.TRI enthalten: / Nur im Komplettsset iD.TRI enthalten:

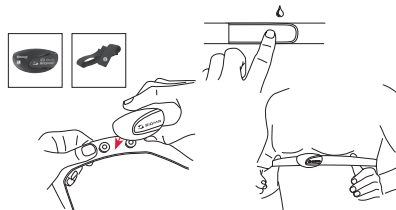
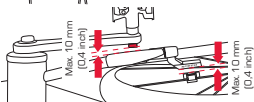
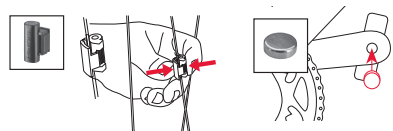
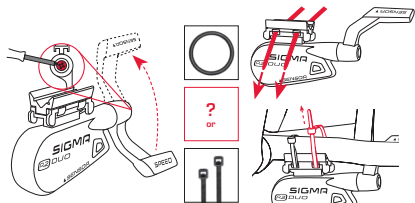

**Further information / Mehr Informationen /
Mehr Informationen / Mehr Informationen /
Mehr Informationen / Mehr Informationen /
Mehr Informationen / Mehr Informationen**

Mehr Informationen finden Sie unter: www.sigma-qr.com

More information can be found here: www.sigma-qr.com

Vous trouverez de plus amples informations ici : www.sigma-qr.com

Maggiori informazioni sono disponibili in: www.sigma-qr.com

Más información encuentra Vd. bajo: www.sigma-qr.com

Meer informatie vindt u onder: www.sigma-qr.com

Dodatkowe informacje można zamieszczone na stronie: www.sigma-qr.com

Další informace naleznete pod: www.sigma-qr.com



RF Interface F	Frequenz Range	Maximum RF output power	Number of Channels
BLE	2402 – 2480 Mhz	4 dBm	39
ANT+	2450 – 2457 MHz	0 dBm	8
GPS	1575.42 MHz	N/A	1
R1 ANT+ / BLE	2.4 GHz / 2.4 GHz	-6.31 dBm / 3.04 dBm	N/A
R2 ANT+ / BLE	2.4 GHz / 2.4 GHz	0.85 dBm / 3.81 dBm	N/A

Temperature Range			
	iD.FREE / iD.TRI	R1 Duo	R2 Duo
Operating Temperature:	-10°C – +50°C	-5°C – +50°C	-10°C – +60°C
Charging Temperature:	0°C – +45°C		

Water Resistance iD.FREE / iD. TRI = 5 ATM

Hiermit erklärt SIGMA-ELEKTRO GmbH, dass sich die iD.FREE und iD.TRI in Übereinstimmung mit den grundlegenden Anforderungen und den anderen relevanten Vorschriften der Richtlinie 2014/53/EU befinden. Sie finden die Konformitätserklärung unter folgendem Link:

ce.sigmasport.com/idfree
ce.sigmasport.com/idtri

SIGMA-ELEKTRO GmbH hereby declares that the iD.FREE and iD.TRI comply with the fundamental requirements and other relevant regulations of Directive 2014/53/EU.

You can find the CE declaration at:

ce.sigmasport.com/idfree
ce.sigmasport.com/idtri

Garantiebedingungen

Die Garantie für Produkte von SIGMA-ELEKTRO GmbH gilt 24 Monate ab Rechnungsdatum und bezieht sich auf mechanische oder technische Probleme (Displaydefekte, Datentransferprobleme, Alterung, optische Mängel). Die Garantie ist nur dann unfänglich gültig, wenn die SIGMA SPORT Produkte auch nur mit den von SIGMA SPORT mitgelieferten bzw. empfohlenen Zubehörkomponenten verwendet werden. Die Garantie bezieht sich aber nicht auf Batterien, Akkus und Verschleißteile (Armbänder, Gummis, Brustgurte etc.) sowie mutwillige Beschädigung und Defekte, verursacht durch falsche Anwendung.

SIGMA-ELEKTRO GmbH

Dr.-Julius-Leber-Straße 15
D-67433 Neustadt/Weinstraße
Service-Tel. +49(0)6321-9120-118
E-Mail: kundenservice@sigmasport.com

Sie finden ein Reklamations-Formular auf unserer Website:
claim.sigmasport.com

Entsorgung

Batterien dürfen nicht im Hausmüll entsorgt werden (Batteriegesetz - BattG)! Bitte geben Sie die Batterien an einer benannten Übergabestelle zur Entsorgung ab.



Elektronische Geräte dürfen nicht im Hausmüll entsorgt werden. Bitte geben Sie das Gerät an einer benannten Entsorgungsstelle ab.



Die CE Erklärung finden Sie unter:
ce.sigmasport.com/idfree
ce.sigmasport.com/idtri

Warranty

The guarantee for SIGMA-ELEKTRO GmbH products is valid for 24 months from the date of invoice and covers mechanical or technical problems (display defects, data transfer problems, mounting, optical defects). The guarantee applies only if the SIGMA SPORT products are used with accessories supplied or recommended by SIGMA SPORT. The guarantee does not apply to batteries, rechargeable batteries and wear parts (wrist straps, rubber straps, chest straps, etc.) as well as deliberate damage and defects caused by incorrect application.

SIGMA-ELEKTRO GmbH

Dr.-Julius-Leber-Straße 15
D-67433 Neustadt/Weinstraße
Service tel. +49-(0)6321-9120-118
Email: kundenservice@sigmasport.com

You can find a complaints form
on our website: claim.sigmasport.com

Disposal

Batteries must not be disposed of in household waste (Battery Law - BattG!) Please take the batteries to an official collection point or to the retailer for disposal.



Electronic devices must not be disposed of in household waste. Please take the device to an official waste collection point.



You can find the CE declaration at:

ce.sigmasport.com/idfree
ce.sigmasport.com/idtri

Condiciones de la garantía

La garantía de productos SIGMA-ELEKTRO GmbH es válida durante 24 meses a partir de la fecha de la factura y se refiere a problemas mecánicos o técnicos (defectos de la pantalla, problemas de transmisión de datos, soporte, defectos ópticos). La garantía es solamente de plena validez si los productos SIGMA SPORT se utilizan solamente con los componentes de accesorios SIGMA SPORT suministrados o recomendados. La garantía no se refiere a baterías, acumuladores y piezas de desgaste (pulseras, gomas, transmisores pectorales, etc.) así como el daño y defecto ocasionado voluntariamente por la utilización errónea.

SIGMA-ELEKTRO GmbH

Dr.-Julius-Leber-Straße 15
D-67433 Neustadt/Weinstraße
Alemania
Tel. de atención al cliente: +49-(0)6321-9120-118
Correo electrónico: kundenservice@sigmasport.com

En nuestra página web claim.sigmasport.com
encontrará un formulario para reclamaciones.

Eliminación

¡Las pilas no deben desecharse en la basura doméstica (Ley alemana de baterías, BattG!) Por favor, lleve las baterías a un puesto de recepción designado para su eliminación.



Los aparatos electrónicos no deben desecharse en la basura doméstica. Por favor, entregue el aparato en un puesto de eliminación designado.



Vd. encuentra la declaración de conformidad bajo el enlace siguiente:

ce.sigmasport.com/idfree
ce.sigmasport.com/idtri

Condizioni di garanzia

La garanzia per i prodotti SIGMA-ELEKTRO GmbH vale 24 mesi a partire dalla data di fatturazione e copre problemi meccanici o tecnici (difetti del display, problemi di trasferimento dati, supporto, vizi estetici). La garanzia è inoltre pienamente valida solo se i prodotti SIGMA SPORT vengono utilizzati esclusivamente con i componenti accessori forniti o consigliati da SIGMA SPORT. Tuttavia la garanzia non copre pile, batterie e parti soggette a usura (cinturini, gomme, fasce toraciche ecc.) nonché danni e difetti intenzionali causati dall'errato utilizzo.

SIGMA-ELEKTRO GmbH

Dr.-Julius-Leber-Straße 15
D-67433 Neustadt/Weinstraße
Tel. assistenza. +49-(0)6321-9120-118
E-mail: kundenservice@sigmasport.com

È possibile trovare un modulo di reclamo sul nostro sito web: claim.sigmasport.com

Smaltimento

Le batterie non devono essere smaltite nei rifiuti domestici (Legge tedesca sulle batterie - BattG)! Portate le batterie in un luogo di raccolta designato per il loro smaltimento.



Gli apparecchi elettrici non devono essere smaltiti nei rifiuti domestici. Portare l'apparecchio in un luogo di raccolta appositamente designato.



La dichiarazione di conformità è disponibile al seguente link:
ce.sigmasport.com/idfree
ce.sigmasport.com/idtri

Conditions de garantie

La garantie sur les produits SIGMA-ELEKTRO GmbH est de 24 mois à compter de la date de la facture et porte sur les problèmes mécaniques ou techniques (défauts d'affichage, problèmes de transfert de données, support, défauts visibles). La garantie ne s'applique dans sa globalité que lorsque les produits SIGMA SPORT n'ont été utilisés qu'avec les accessoires fournis ou recommandés par SIGMA SPORT. La garantie ne concerne pas les piles, batteries et pièces d'usure (bracelets, caoutchoucs, ceintures thoraciques, etc.), ainsi que les dommages et défauts volontaires causés par une mauvaise utilisation.

SIGMA-ELEKTRO GmbH

Dr.-Julius-Leber-Straße 15
D-67433 Neustadt/Weinstraße
Tél. Service +49-(0)6321-9120-118
E-mail : kundenservice@sigmasport.com

Vous trouverez un formulaire de réclamation sur notre site Web, à l'adresse : claim.sigmasport.com

Élimination

Les piles ne peuvent pas être jetées dans les ordures ménagères (loi allemande relative aux piles - BattG) ! Veuillez rapporter vos piles dans un centre de collecte agréé.



Les appareils électroniques ne peuvent pas être jetés dans les ordures ménagères. Veuillez rapporter votre appareil dans un centre de collecte agréé.



La déclaration de conformité est disponible à l'adresse suivante :
ce.sigmasport.com/idfree
ce.sigmasport.com/idtri

Garantie bepalingen

De garantie voor producten van SIGMA-ELEKTRO GmbH geldt gedurende 24 maanden vanaf de factuurdatum en heeft betrekking op mechanische of technische problemen (displaydefecten, data-overdrachtproblemen, houder, optische gebreken). De garantie is alleen geldig wanneer de SIGMA SPORT producten ook uitsluitend met de door SIGMA SPORT meegeleverde, resp. aanbevolen toebehoren worden gebruikt. De garantie geldt niet voor batterijen, accu's en slijtdelen (armbanden, rubbers, borstrijmen etc.) en moedwillige beschadiging en defecten, veroorzaakt door verkeerd gebruik.

SIGMA-ELEKTRO GmbH

Dr.-Julius-Leber-Straße 15
D-67433 Neustadt/Weinstraße
Service-Tel. +49-(0)6321-9120-118
E-mail: kundenservice@sigmasport.com

Een klachtenformulier is te vinden op onze website: claim.sigmasport.com

Afvoer

Batterijen mogen niet bij het huishoudelijk afval (Duitse batterijwet - BattG)! Geef de batterijen af bij een daarvoor bestemde inzamelplaats.



Elektronische apparaten mogen niet bij het huishoudelijk afval terechtkomen. Geef het apparaat af bij een daarvoor bestemde afvalverzamelplaats.



U vindt de conformiteitsverklaring onder de volgende link:
ce.sigmasport.com/idfree
ce.sigmasport.com/idtri

Záruční podmínek

Záruční lhůta na výrobky SIGMA-ELEKTRO GmbH platí po dobu 24 měsíců od data uvedeního na účtence a vztahuje se na mechanické nebo technické závady (vady displeje, poruchy přenosu dat, vady držáku, optické vady). Záruka platí v plném rozsahu pouze za předpokladu, že výrobky SIGMA SPORT jsou používány pouze s komponenty dodávanými, popř. doporučenými společností SIGMA SPORT. Záruka se však nevztahuje na baterie, akumulátory a opotřebitelné díly (náramky, gumy, hrudní pásy atd.) a dále na úmyslné poškození nebo vady vzniklé nesprávným použitím.

SIGMA-ELEKTRO GmbH

Dr.-Julius-Leber-Straße 15
D-67433 Neustadt/Weinstraße
tel. servisu +49-(0)6321-9120-118
e-mail: kundenservice@sigmasport.com

Formulář pro reklamaci najdete na našich internetových stránkách claim.sigmasport.com

Likvidace

Baterie se nesmějí likvidovat s domovním odpadem (německý zákon o bateriích BattG)! Odevzdejte prosím baterie na příslušném sběrném místě k likvidaci odpadu.



Elektronické přístroje se nesmějí likvidovat jako domovní odpad. Odevzdejte prosím přístroj na příslušném sběrném místě k likvidaci odpadu.



Prohlášení o shodě najdete pod následujícím odkazem:
ce.sigmasport.com/idfree
ce.sigmasport.com/idtri

Warunki gwarancji

Gwarancja na produkty SIGMA-ELEKTRO GmbH wynosi 24 miesiące od daty zakupu i obejmuje usterki mechaniczne oraz problemy techniczne (wady wyświetlacza, problemy z transmisją danych, chwyt, wady wizualne). Gwarancja obowiązuje w pełnym zakresie wyłącznie pod warunkiem użytkowania produktów SIGMA SPORT z dostarczonymi lub rekomendowanymi przez SIGMA SPORT akcesoriami. Gwarancja nie są objęte baterie, akumulatory i części zużywalne [opaski, gumki, paski na klatkę piersiową itp.] oraz celowe uszkodzenia lub wady spowodowane nieprawidłowym użytkowaniem.

SIGMA-ELEKTRO GmbH

Dr.-Julius-Leber-Straße 15
D-67433 Neustadt/Weinstraße, Niemcy
Tel. +49-(0)6321-9120-118
E-Mail: kundenservice@sigmasport.com

Formularz reklamacyjny można znaleźć
na naszej stronie: claim.sigmasport.com

Utylizacja

Baterie nie wolno wyrzucać wraz z odpadami domowymi (Ustawa z dnia 24 kwietnia 2009 r. o bateriach i akumulatorach, Dz. U. Nr 79, poz. 666)! Baterie należy przekazać do utylizacji w odpowiednim punkcie zbiórki odpadów.



Urządzeń elektronicznych nie wolno wyrzucać wraz z odpadami domowymi. Po zakończeniu użytkowania, urządzenie należy przekazać do utylizacji w odpowiednim punkcie zbiórki odpadów.



Deklaracja zgodności jest dostępna na stronie:
ce.sigmasport.com/idfree
ce.sigmasport.com/idtri

Garancijski pogoj

Garancija za izdelke SIGMA-ELEKTRO GmbH velja 24 mesecev od datuma računa in se nanaša na mehanske ali tehnične težave (okvare zasлона, težave pri prenosu podatkov, držalo, vizualne napake). Garancija velja v polnem obsegu le, če se izdelki SIGMA SPORT tudi uporabljajo s priloženimi oz. priporočenimi komponentami opreme SIGMA SPORT. Garancija se ne nanaša na baterije, polnilne baterije in obrabne dele (zapestnice, elastične, prsne pasove itn.) ter namerne poškodbe in okvare, povzročene zaradi napačne uporabe.

SIGMA-ELEKTRO GmbH

Dr.-Julius-Leber-Straße 15
D-67433 Neustadt/Weinstraße
Tel. za svetovanje kupcem +49-(0)6321-9120-118
E-naslov: kundenservice@sigmasport.com

Obrazec za reklamacije najdete
na naši spletni strani: claim.sigmasport.com

Odstranjanje

Baterij skladno z veljavnimi predpisi ne smete odvreči med gospodinske odpadke. Prosimo, da baterije oddate na ustreznem odlagališču.



Elektronskih naprav ne smete odvreči med gospodinske odpadke. Prosimo, da napravo oddate na ustreznem odlagališču.



Izjavo o skladnosti najdete na povezavi:
ce.sigmasport.com/idfree
ce.sigmasport.com/idtri

Záručné podmienky

Záruka na výrobky značky SIGMA-ELEKTRO GmbH platí po dobu 24 mesiacov od dátumu vystavenia faktúry a vzťahuje sa na mechanické alebo technické problémy (poruchy displeja, problémy s prenosom údajov, prichytením či optické nedostatky). Záruka je v plnom rozsahu platná iba vtedy, ak sa výrobky značky SIGMA SPORT používajú iba s dodávanými, resp. značkou SIGMA SPORT odporúčanými komponentmi príslušenstva. Záruka sa však nevzťahuje na batérie, akumulátory alebo opotrebovateľné diely (náramky, gumové diely, hrudné pásy atď.), ako aj svojvoľné poškodenia či defekty spôsobené nesprávnym použitím.

SIGMA-ELEKTRO GmbH

Dr.-Julius-Leber-Straße 15
D-67433 Neustadt/Weinstraße
Servisné tel. č.: +49-(0)6321-9120-118
E-mail: kundenservice@sigmasport.com

Reklamačný formulár nájdete na našej internetovej stránke: claim.sigmasport.com

Likvidácia

Batérie sa nesmú likvidovať v komunálnom odpade (Zákon o batériách – BattG)! Batérie odovzdajte s cieľom likvidácie na určenom mieste odovzdania.



Elektronické zariadenia sa nesmú likvidovať v komunálnom odpade. Zariadenie odovzdajte na určenom mieste likvidácie.



Vyhľadanie o zhode nájdete na nasledujúcom odkaze:
ce.sigmasport.com/idfree
ce.sigmasport.com/idtri

Takuuehdot

SIGMA-ELEKTRO GmbH -tuotteiden takuu on voimassa 24 kuukautta laskupäivämäärästä lähtien ja se kattaa mekaaniset ja tekniset ongelmat (näyttöviat, tiedonsiirto-ongelmat, pidike, optiset viat). Takuu on voimassa kattavasti vain, kun SIGMA SPORT -tuotteita käytetään ainoastaan SIGMA SPORT -tuotteen mukana toimitettujen ja/ tai suositeltavien tarvikoesien kanssa. Takuu ei kata paristoja, akkuja ja kuluvia osia (rannekkeet, kumet, rintavyöt yms.) eikä tahallista vahingoittamista tai virheellisestä käytöstä syntyviä vikoja.

SIGMA-ELEKTRO GmbH

Dr.-Julius-Leber-Straße 15
D-67433 Neustadt/Weinstraße
Palvelupuh. +49-(0)6321-9120-118
S-posti: kundenservice@sigmasport.com

Reklamaatiolomake löytyy verkkosivustoltamme: claim.sigmasport.com

Hävittäminen

Akkuja ei saa hävittää kotitalousjätteen mukana (Saksassa: paristolaki - BattG)! Luovuta akut johonkin viralliseen keruupisteeseen hävitettäväksi.



Elektroniikkalaitteita ei saa hävittää kotitalousjätteen mukana. Luovuta laite johonkin viralliseen keruupisteeseen.



Vaatumustenmukaisuusilmoitus löytyy linkistä:
ce.sigmasport.com/idfree
ce.sigmasport.com/idtri

Garanti

Garantien på SIGMA-ELEKTRO GmbH-produkter gælder i 24 måneder fra fakturadato og dækker mekaniske eller tekniske problemer (displaydefekter, dataoverførselsproblemer, montering, optiske defekter). Garantien gælder kun, hvis SIGMA SPORT-produkterne anvendes med tilbehør leveret eller anbefalet af SIGMA SPORT. Garantien dækker ikke batterier, genopladelige batterier og sliddele (fodstroppe, gummistroppe, bryststroppe osv.) eller bevidst beskadigelse og defekter forårsaget af forkert anvendelse.

SIGMA-ELEKTRO GmbH

Dr.-Julius-Leber-Straße 15
D-67433 Neustadt/Weinstraße
Servicetilf. +49-(0)6321-9120-118
E-mail: kundenservice@sigmasport.com

Der ligger klageformularer på vores hjemmeside:
claim.sigmasport.com

Bortskaffelse

Batterier må ikke smides ud sammen med det almindelige husholdningsaffald (batterilov - BattG)! De skal bortskaffes i overensstemmelse med de lokale retningslinjer.



Elektroniske apparater må ikke smides ud sammen med det almindelige husholdningsaffald. Apparatet skal bortskaffes på en officiel genbrugsstation.



Komfimerterklæringen kan findes her:
ce.sigmasport.com/idfree
ce.sigmasport.com/idtri

Garanti

Garantien på SIGMA-ELEKTRO GmbH-produkter er gyldig i 24 måneder fra fakturadatoen og dækker mekaniske og tekniske problemer (displaydefekter, dataoverføringsproblemer, montering, optiske defekter). Denne garanti gælder kun hvis SIGMA SPORT-produkter blir brukt med tilbehør som er levert eller anbefalt av SIGMA SPORT. Garantien gjelder ikke batterier, oppladbare batterier og slitasjedeler (håndleddsstroppe, gummistroppe, bryststroppe, etc.) i tillegg til bevisste skader og defekter forårsaket av feil bruk.

SIGMA-ELEKTRO GmbH

Dr.-Julius-Leber-Straße 15
D-67433 Neustadt/Weinstraße
Servicetelefon. +49-(0)6321-9120-118
E-post: kundenservice@sigmasport.com

Du finner et klageskjema på nettsiden:
claim.sigmasport.com

Kassering

Batterier må ikke kasseres med husholdningsaffald (Batterilov - BattG)! Kasser i henhold til lokale forskrifter.



Elektroniske enheter må ikke kasseres med husholdningsaffald. Lever inn enheten på et offentlig innsamlingspunkt.



finder samsvarserklæringen på følgende lenke:
ce.sigmasport.com/idfree
ce.sigmasport.com/idtri

Garanti

Garantin för SIGMA-ELEKTRO GmbH produkter är giltig i 24 månader från faktureringsdatumet och omfattar tekniska eller tekniska problem (displayfel, problem med dataöverföring, fäste, optiska defekter). Garantin gäller endast om SIGMA SPORT:s produkter används med medföljande tillbehör eller tillbehör som har rekommenderats av SIGMA SPORT. Garantin omfattar inte batterier, laddningsbara batterier och slitagedelar (handledsband, elastiska remmar, bröstremmar, osv) liksom avsiktliga skador och defekter som orsakats av felaktig tillämpning.

SIGMA-ELEKTRO GmbH

Dr.-Julius-Leber-Straße 15
D-67433 Neustadt-/Weinstraße
Servicetel. +49-(0)6321-9120-118
E-post: kundenservice@sigmasport.com

Du hittar ett klagomålsformulär på vår webbplats: claim.sigmasport.com

Kassering

Batterier skall inte kastas tillsammans med hushållsavfall (batterilag - BattG)! Kassera korrekt enligt lokala bestämmelser.



LI =
Lithium Ionen

Elektronisk utrustning skall inte kastas tillsammans med hushållsavfall. Ta apparaten till en offentlig insamlingsplats för avfall.



Du hittar försäkrän om överensstämmelse via följande länk:
ce.sigmasport.com/idfree
ce.sigmasport.com/idtri

Condições da garantia

A garantia para os produtos da SIGMA-ELEKTRO GmbH é válida por 24 meses a contar da data da fatura e abrange problemas mecânicos ou técnicos (defeitos do ecrã, problemas de transferência de dados, suporte, defeitos visuais). A garantia apenas é extensivamente válida, se os produtos SIGMA SPORT forem utilizados apenas com os acessórios fornecidos em conjunto ou recomendados pela SIGMA SPORT. Contudo, a garantia não abrange pilhas, baterias e peças de desgaste (braceletes, elásticos, cintas peitorais, etc.), assim como danos intencionais e defeitos causados por utilização incorreta.

SIGMA-ELEKTRO GmbH

Dr.-Julius-Leber-Straße 15
D-67433 Neustadt-/Weinstraße
Tel. assistência +49-(0)6321-9120-118
E-mail: kundenservice@sigmasport.com

Está disponível um formulário para reclamações na nossa página da Internet: claim.sigmasport.com

Eliminação

As baterias não podem ser eliminadas através do lixo doméstico (lei sobre baterias - BattG)! Entregue as baterias para eliminação num centro de recolha designado.



LI =
Lithium Ionen

Os aparelhos eletrónicos não podem ser eliminados através do lixo doméstico. Entregue o aparelho num centro de eliminação designado.



Encontra a declaração de conformidade no seguinte link:
ce.sigmasport.com/idfree
ce.sigmasport.com/idtri

Гарантии для изделий SIGMA-ELEKTRO GmbH действительны 24 месяца с момента выставления счета и относятся к механическим или техническим неполадкам: дефектам дисплея, проблемам передачи данных, креплению, оптическим дефектам. Обширная гарантия действительна только в том случае, если изделия SIGMA SPORT используются вместе с поставляемыми или рекомендованными аксессуарами SIGMA SPORT. Гарантия не распространяется на аккумуляторы, аккумуляторные батареи и износ деталей (браслеты, резину, грубые ремни и т. д.) и умышленное повреждение или дефекты, вызванные неправильным использованием.

SIGMA-ELEKTRO GmbH

Dr.-Julius-Leber-Straße 15
D-67433 Neustadt-/Weinstraße (Германия)
Тел. сервисной службы: +49(0)6321-9120-118
Эл. почта: kundenservice@sigmasport.com

Формы жалоб доступны на нашем сайте:
claim.sigmasport.com

Утилизация

Батареи запрещается утилизировать вместе с бытовыми отходами (Закон Германии об утилизации батарей (BattG)!) Сдавайте батареи в специализированные пункты сбора.



LI =
Lithium Ionen

Электронные приборы запрещается утилизировать вместе с бытовым мусором. Сдайте устройство в специализированный пункт сбора.



Заявление о соответствии товара доступно по адресу
ce.sigmasport.com/idfree
ce.sigmasport.com/idtri

Гаранцията за продукти на SIGMA-ELEKTRO GmbH важи 24 месеца от датата на покупка и се отнася до механични или технически проблеми (дефекти на дисплея, проблеми при трансфер на данни, държач, оптически недостатъци). Гаранцията важи напълно само тогава, когато продуктите на SIGMA SPORT се използват само с предоставените или препоръчаните от SIGMA SPORT допълнителни аксесоари. Гаранцията не покрива батерии, акумулатори и износващи се части (кашишки, гумички, нагръдни колани и др.), както и предпазено повреждане и дефекти, предизвикани от неправилна употреба.

SIGMA-ELEKTRO GmbH

Dr.-Julius-Leber-Straße 15
D-67433 Neustadt-/Weinstraße
Сервизен тел. +49(0)6321-9120-118
Имейл: kundenservice@sigmasport.com

Формуляр за рекламации ще откриете
на нашия уебсайт: claim.sigmasport.com

Изхвърляне

Батериите не трябва да се изхвърлят заедно с битовите отпадъци! Предайте батериите в съответните събирателни пунктове.



LI =
Lithium Ionen

Електронните уреди не бива да се изхвърлят заедно с битовите отпадъци. Предайте уреда в съответните събирателни пунктове.



Ще намерите декларацията за съответствие на следния адрес:
ce.sigmasport.com/idfree
ce.sigmasport.com/idtri

Condiții de garanție

Perioada de garanție a produselor SIGMA-ELEKTRO GmbH este de 24 de luni de la data facturii și se acordă pentru probleme mecanice sau tehnice (defecte ale display-ului, probleme la transferul datelor, prinderi, defectiuni optice). Garanția este acordată doar dacă produsele SIGMA SPORT sunt utilizate cu accesoriile livrate de către SIGMA SPORT, respectiv cu accesoriile recomandate. Garanția nu se acordă bateriilor, acumulatorilor sau componentelor supuse uzurii (brățările, componentelor din cauciuc, hamurilor pentru piept etc.) precum și deteriorarea intenționată și defectelor cauzate de utilizarea incorectă.

SIGMA-ELEKTRO GmbH

Dr.-Julius-Leber-Straße 15
D-67433 Neustadt/Weinstraße
Telefon service: +49(0)632 1-9120-118
E-mail: kundenservice@sigmasport.com

Puteți găsi formularul pentru reclamații pe site-ul nostru web:
claim.sigmasport.com

Eliminarea

Bateriile nu se vor arunca împreună cu gunoiul menajer (legea pentru baterii - BattG)! Bateriile se vor preda la un centru special amenajat pentru colectare.



LI =
Lithium Ionen

Aparatele electrice nu se vor salubriza împreună cu gunoiul menajer. Vă rugăm să predați aparatul la un centru de colectare desemnat în acest scop.



Puteți găsi Declarația de conformitate la următorul link:

ce.sigmasport.com/idfree
ce.sigmasport.com/idtri

Garanți condiții

SIGMA-ELEKTRO GmbH firmasina ait: ürünlerne yönelik garanti fatura tarihinden sonra 24 ay geçerlidir ve mekanik veya teknik sorunlar ile ilgilidir (ekran efektleri, veri aktarım sorunları, tutucu, optik kusurlar). Garanti sadece SIGMA SPORT ürünleri sadece SIGMA SPORT firması tarafından birlikte teslim edilen ya da tavsiye edilen aksesuar bileşenleri ile kullanılırsa kapsamlı olarak geçerlidir. Garanti bataryalar, aküler ve aşınma parçaları (bileklikler, lastikler, kayışlar vs.) ve yanlış kullanım nedeniyle meydana gelen kasıtlı hasar ve arızalar ile ilgili değildir.

SIGMA-ELEKTRO GmbH

Dr.-Julius-Leber-Straße 15
D-67433 Neustadt/Weinstraße
Servis tel. +49(0)632 1-9120-118
E-posta: kundenservice@sigmasport.com

Web sayfamızda bir şikayet formu bulabilirsiniz:
claim.sigmasport.com

Tasfiye

Bataryalar ev çöpünde tasfiye edilmemelidir (batarya yasası - BattG)! Lütfen pilleri tanımlanmış bir toplama yerine teslim edin.



LI =
Lithium Ionen

Elektronik cihazlar evsel atıklarla birlikte tasfiye edilmemelidir. Lütfen cihazı belirtilen bir tasfiye birimine verin.



Uygunluk beyanını aşağıdaki bağlantı üzerinden bulabilirsiniz:

ce.sigmasport.com/idfree
ce.sigmasport.com/idtri

Federal Communication Commission Interference Statement

This device complies with Part 15 of the FCC Rules. Operation is subject to the following two conditions:

- (1) This device may not cause harmful interference, and
- (2) this device must accept any interference received, including interference that may cause undesired operation.

This equipment has been tested and found to comply with the limits for a Class B digital device, pursuant to Part 15 of the FCC Rules. These limits are designed to provide reasonable protection against harmful interference in a residential installation. This equipment generates, uses and can radiate radio frequency energy and, if not installed and used in accordance with the instructions, may cause harmful interference to radio communications. However, there is no guarantee that interference will not occur in a particular installation. If this equipment does cause harmful interference to radio or television reception, which can be determined by turning the equipment off and on, the user is encouraged to try to correct the interference by one of the following measures:

- Reorient or relocate the receiving antenna.
- Increase the separation between the equipment and receiver.
- Connect the equipment into an outlet on a circuit different from that to which the receiver is connected.
- Consult the dealer or an experienced radio/TV technician for help.

FCC Caution:

Any changes or modifications not expressly approved by the party responsible for compliance could void the user's authority to operate this equipment. This transmitter must not be co-located or operating in conjunction with any other antenna or transmitter.

Radiation Exposure Statement:

The product comply with the FCC portable RF exposure limit set forth for an uncontrolled environment and are safe for intended operation as described in this manual. The further RF exposure reduction can be achieved if the product can be kept as far as possible from the user body or set the device to lower output power if such function is available.

Industry Canada statement

This device complies with ISED's licence-exempt RSSs. Operation is subject to the following two conditions:

- (1) This device may not cause harmful interference, and
- (2) this device must accept any interference received, including interference that may cause undesired operation.

Le présent appareil est conforme aux CNR d'ISED applicables aux appareils radio exempts de licence. L'exploitation est autorisée aux deux conditions suivantes :

- (1) le dispositif ne doit pas produire de brouillage préjudiciable, et
- (2) ce dispositif doit accepter tout brouillage reçu, y compris un brouillage susceptible de provoquer un fonctionnement indésirable.

Do not disassemble, modify or repair this product, as this may cause a fire, electric shock or product damage. Any modification will void the warranty of this product.

Ne pas démonter, modifier ni réparer ce produit, car cela pourrait provoquer un feu, un choc électrique ou un dommage produit. Toute modification annulera la garantie de ce produit.

This Class B digital apparatus complies with Canadian CAN ICES-3 (B)/NMB-3 (B).

Cet appareil digital de classe B est homologué CAN ICES-3 (B)/NMB-3 (B) pour le Canada.

Radiation Exposure Statement:

The product comply with the Canada portable RF exposure limit set forth for an uncontrolled environment and are safe for intended operation as described in this manual. The further RF exposure reduction can be achieved if the product can be kept as far as possible from the user body or set the device to lower output power if such function is available.

Déclaration d'exposition aux radiations:

Le produit est conforme aux limites d'exposition pour les appareils portables RF pour les États-Unis et le Canada établies pour un environnement non contrôlé. Le produit est sûr pour un fonctionnement tel que décrit dans ce manuel. La réduction aux expositions RF peut être augmentée si l'appareil peut être conservé aussi loin que possible du corps de l'utilisateur ou que le dispositif est réglé sur la puissance de sortie la plus faible si une telle fonction est disponible.

ID.FREE ***ID.TRI***

SIGMA-ELEKTRO GmbH

Dr.-Julius-Leber-Straße 15
D-67433 Neustadt/Weinstraße
Tel. + 49 (0) 63 21-9120-0
Fax. + 49 (0) 63 21-9120-34
E-mail: info@sigmasport.com

SIGMA SPORT USA LLC

North America
1860B Dean St.
St. Charles, IL 60174, U.S.A.
Tel. +1 630-761-1106
Fax. +1 630-761-1107
Service-Tel. 888-744-6277

SIGMA SPORT (Hong Kong) Ltd

Room 2010, 20/F, No.1 Hung To Road,
Kwun Tong, Kowloon, Hong Kong

284100/1



www.sigmasport.com