

55101 521



Advanced Video Imaging

**OPERATING GUIDE
&
WARRANTY**



THE QUALITY GOES IN BEFORE THE NAME GOES ON[®]

¡Aviso para nuestros
clientes de habla hispana:
consulte la información que
aparece al final de este manual!

**Projection Color TV
MTS Stereo Audio
Surround Sound
Closed Captions**

Operating Guide #206-2738

#54002 PV4663RK
#54012 PV5263RK



recycled paper
50 percent

**Return the Product Registration
Card, and your TV could be free!**



WARNING
RISK OF ELECTRIC SHOCK
DO NOT OPEN



WARNING: TO REDUCE THE RISK OF ELECTRIC SHOCK DO NOT REMOVE COVER (OR BACK). NO USER SERVICEABLE PARTS INSIDE. REFER TO QUALIFIED SERVICE PERSONNEL.

TO PREVENT FIRE OR SHOCK HAZARDS, DO NOT EXPOSE THIS PRODUCT TO RAIN OR MOISTURE.



The lightning flash with arrowhead symbol, within an equilateral triangle, is intended to alert the user to the presence of uninsulated "dangerous voltage" within the product's enclosure that may be of sufficient magnitude to constitute a risk of electric shock to persons.



The exclamation point within an equilateral triangle is intended to alert the user to the presence of important operating and maintenance (servicing) instructions in the literature accompanying the appliance.

Safety Tips

Refer to the "Safety Tips" booklet that came with your product for important safety considerations.

Note to Cable TV System Installer

This reminder is provided to call the cable TV system installer's attention to Article 820-40 of the NEC that provides guidelines for proper grounding and, in particular, specifies that the cable ground shall be connected to the grounding system of the building, as close to the point of the cable entry as practical.

Power-Cord Polarization

This product is equipped with a polarized alternating-current line plug (a plug having one blade wider than the other.) This plug will fit into the power outlet only one way. This is a safety feature. If you are unable to insert the plug fully into the outlet, try reversing the plug. If the plug should still fail to fit, contact your electrician to replace your obsolete outlet. Do not defeat the safety purpose of the polarized plug.

CAUTION

To prevent electric shock, match wide blade of plug to wide slot, fully insert.

ATTENTION

Pour éviter les chocs électriques, introduire la lame la plus large de la fiche dans la borne correspondante de la prise et pousser jusqu'au fond.

CONTENTS

INTRODUCTION

Welcome	ii
Installation Considerations	ii

CONNECTIONS FOR YOUR TV

Locations of User Items	1-1
Connection Center on Back of TV	1-2
Other A/V Jacks on TV	1-2
Step 1. Make Basic Connection to TV	1-3
Step 2. Make VCR Connections to TV	1-4
Step 3. Make Super-VHS VCR Connections to TV	1-5
Step 4. Make A/V Connections to Auxiliary A/V Jacks (VIDEO 3 IN or S-VIDEO 2 IN)	1-5
Step 5. Make Connections to Monitor Out Jacks	1-5
Step 6. Make Surround Sound Connections to TV	1-6
Step 7. Make External Speaker Connections to TV	1-6
Step 8. Make Audio Connection to Stereo Amplifier	1-7

THE FIRST TIME YOU OPERATE YOUR TV

Step 1. Connect the Power	2-1
Step 2. Select Your Viewing Source	2-1
Step 3. Use Auto Program	2-1
Step 4. Time Functions	2-1
Step 5. Use Other Options	2-2

REMOTE CONTROL MODEL SC3820

TV Operations	3-1
VCR Operations	3-2
TV and VCR Operational Notes	3-3
Preparation for Use	3-3
Installing Batteries	3-3

REMOTE CONTROL MODEL MBR3430

Operation	4-1
Choose the Operating Mode	4-1
TV Operations	4-2
VCR Operations	4-3
Cable-TV Operations	4-4
Preparation for Use	4-5
Installing Batteries	4-5
Auto Find Mode	4-5
Programming Brand Codes	4-6
TV, VCR and Cable-TV Operating Codes	4-7

QUICK REFERENCE TO ON-SCREEN MENUS

Available Menus	5-1
Summary of Menu Items	5-1
Menu Operation Example	5-3

SOURCE MENU

Source Selection	6-1
Source Identification	6-1

SETUP MENU

Auto Program	7-1
Ch. Add/Del.	7-1
Ch. Labels	7-2
Tuning Band	7-3
Auto Tuning	7-3
Source ID	7-3
Clock Set	7-4
Captions	7-4
Projo Setup	7-5

AUDIO MENU

Bass	8-1
Treble	8-1
Balance	8-1
Audio	8-1
SEQ	8-1
Surround	8-1

VIDEO MENU

Contrast	9-1
Brightness	9-1
Color	9-1
Tint	9-1
Sharpness	9-1
Color Temp	9-1
Video Filter	9-1
Auto Flesh	9-1
Picture Pref	9-1

PIP MENU

Ch. Guide	10-1
Ch. Review	10-2
PIP Source	10-2
PIP Color	10-3
PIP Tint	10-3
PIP Size	10-3

PIP OPERATION AND CONNECTIONS

PIP Overview	11-1
Typical Connections	11-1
How to Select Main Picture & PIP Source	11-3
PIP Functions	11-4

MAINTENANCE AND TROUBLESHOOTING

Caring for Your TV	12-1
Extended Absence	12-1
TV Picture Interference	12-1
Before Calling for Service	12-2

Product Registration Card

Recommended Accessories For Your Television

Aviso para nuestros clientes de habla hispana

Your Zenith Warranty

HOW TO USE YOUR OPERATING GUIDE

THIS OPERATING GUIDE DESCRIBES A FAMILY OF TV MODELS. SOME MODELS HAVE FEATURES THAT ARE NOT PROVIDED ON OTHER MODELS, SUCH AS AUXILIARY JACKS OR TWO REMOTE CONTROLS. DIFFERENT CONTROL PANELS AND REMOTE CONTROLS MAY BE USED FROM MODEL-TO-MODEL. REFER TO THE APPLICABLE SECTIONS OF THIS OPERATING GUIDE FOR THE FEATURES AND ITEMS PROVIDED WITH YOUR TV.

INTRODUCTION

WELCOME

Welcome into the family of Zenith Color Television owners. This guide provides instructions on how to operate your new TV. It is supplemented by a booklet containing Safety Tips. We urge you to read these publications carefully so that you will receive full enjoyment from your new Zenith TV for many years to come.

Your new Zenith projection TV has been designed and built to give you the very best in quality, features and performance. There are many regional Zenith distributors and thousands of distributor-approved Zenith service centers throughout the U.S., Canada and Mexico who can attend promptly and effectively to ordinary service needs.

If you should have an unusual performance or service problem that cannot be satisfactorily resolved by your distributor-approved Zenith service center, contact the regional Zenith distributor in your area, or write:

Zenith Electronics Corporation
Customer Service Department
1900 N. Austin Avenue
Chicago, Illinois 60639-5079
Telephone: (312) 745-5152
Mon-Fri, 8:00 a.m. - 4:30 p.m. Central Time

Send the model number, serial number, and date of purchase or original installation, with a full explanation of the problem and the service history. We will welcome the opportunity to look into your specific question or problem and to be of assistance in resolving it promptly.

The model and serial numbers of your new TV are located on the back of the TV cabinet. For your future convenience and protection, we suggest that you record these numbers here:

Model No. _____

Serial No. _____

INSTALLATION CONSIDERATIONS

Before you install your TV...



Ventilation — Proper ventilation keeps your TV running cool. Air circulates through perforations in the back and bottom of the cabinet. Do not block these vents or you will shorten the life of your TV.



Power Source — Your TV is designed to operate on normal household current, 120 volt 60 Hertz AC. Do not attempt to operate it on DC current.



Power Cord — Your power cord has a polarized plug as required by Underwriters' Laboratories. It has one regular blade and one wide blade and fits only one way into a standard electrical outlet. If the blades will not enter either way, your outlet is very old and non-standard. A new outlet should be installed by a qualified electrician.



Safe Operation — Your TV is manufactured and tested with your safety in mind. However, unusual stress caused by dropping or mishandling, exposure to flood, fire, rain or moisture, or accidental spilling of liquids into the TV, can result in potential electrical shock or fire hazards. If this happens, have your TV checked by a service technician before using it again.

Please read and observe each safety point in the "Safety Tips" folder when installing and using your TV.

FIXED PATTERN DISPLAY CAUTION — If you use your TV for video games, teletext or other fixed displays, avoid setting the BRIGHTNESS control for an excessively bright picture. A bright, fixed pattern, if used for long periods of time, can result in a permanent imprint on the TV picture tube. You can reduce this possibility by alternating the use of the fixed pattern display with normal TV picture viewing, by turning down the CONTRAST control for sustained fixed pattern use, and by turning off the fixed pattern display when not in use.

PICTURE SCREEN CLEANING — Use a soft cloth moistened with warm water and rub lightly in the soiled areas of the screen. DO NOT USE A TISSUE OR PAPER TOWEL, AS THESE MAY DAMAGE SURFACE. Wipe only in the vertical (up/down) direction (along the grooves). If there is a dirt buildup, a mild solution of warm water and Ivory dishwashing detergent may be used. Use dry soft cloth to dry the screen. Care should be taken to avoid scratches or damage to the screen surface.

NOTE — The TV screen is easily damaged. Avoid accidental contact with the screen.

CONNECTIONS FOR YOUR TV

LOCATIONS OF USER ITEMS

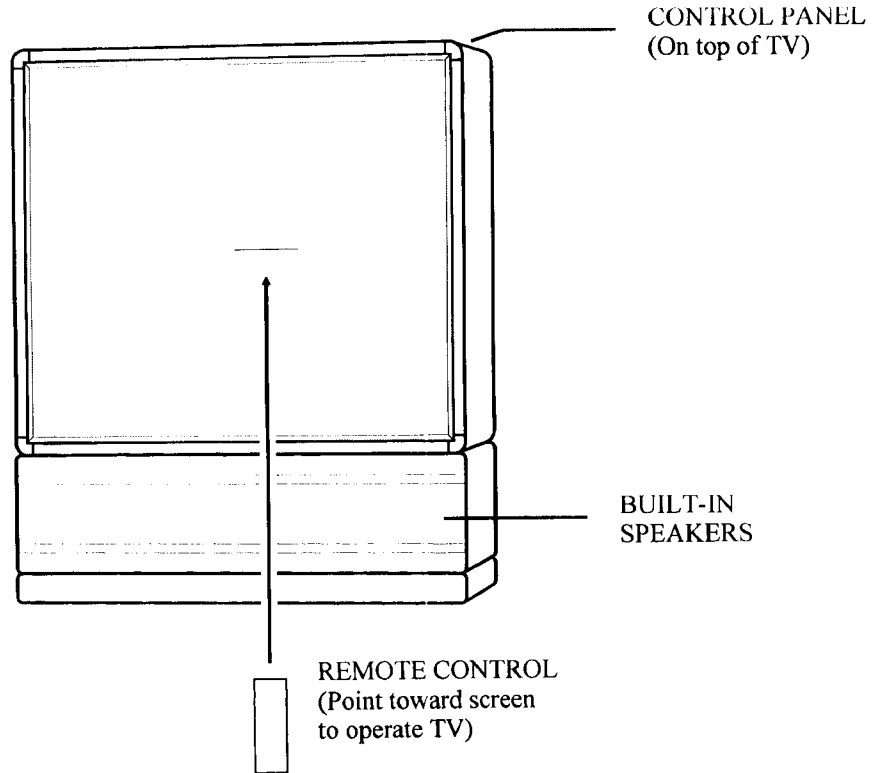

Front View of TV

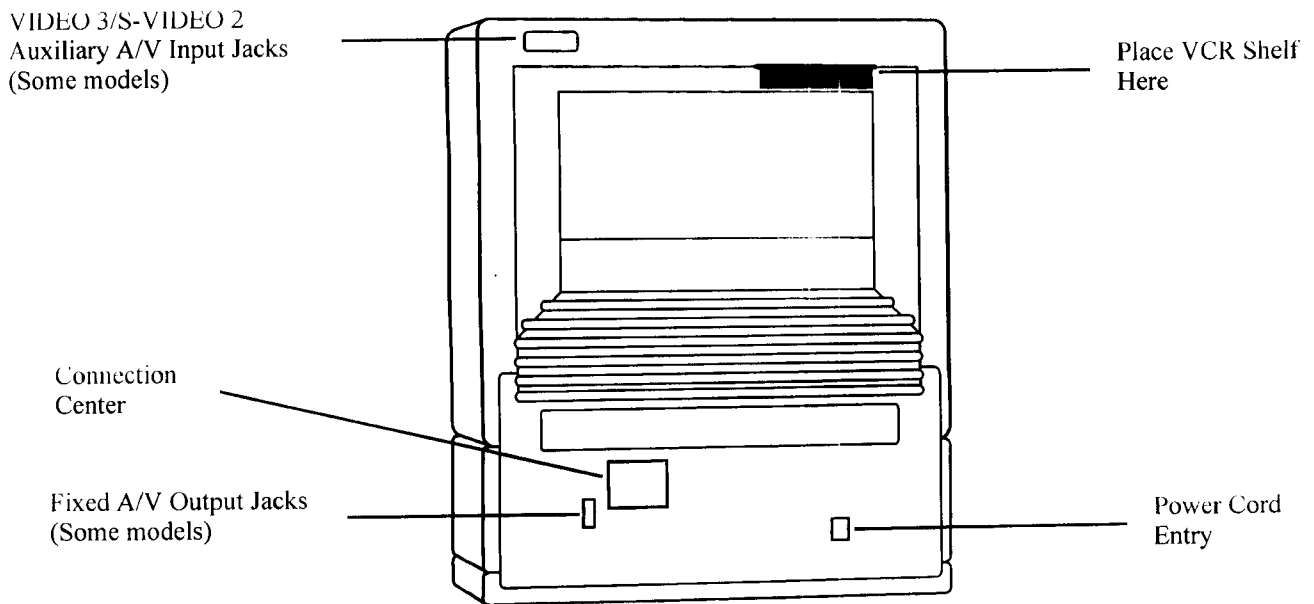

Rear View of TV

CONNECTIONS FOR YOUR TV

CONNECTION CENTER ON BACK OF TV

ANT/CABLE 1 or ANT/CABLE 2

75-ohm antenna-type connections to your TV. Attach your antenna, cable-TV line or VCR to either of these jacks.

EXTERNAL AMP

Standard phono jack connectors for output to the customer's audio amplifier or terminals for connecting external speakers.

LOOP OUT TO DECODER

Use this output to route the cable-TV signal back to the decoder supplied by your cable-TV system.

VIDEO 1 IN or VIDEO 2 IN

Baseband audio and video input from a VCR or other A/V component.

VIDEO 1 LOOP OUT

Use these jacks to send the incoming audio and video signals (from VIDEO 1 IN) to another A/V component, such as a second VCR.

SPEAKERS EXT/INT

EXT position: TV's speakers are off.

INT position: TV's speakers are on.

SURROUND SPEAKER

Terminal connectors for output to optional surround sound speakers.

S-VIDEO 1 IN

Audio and video input from a Super-VHS VCR.

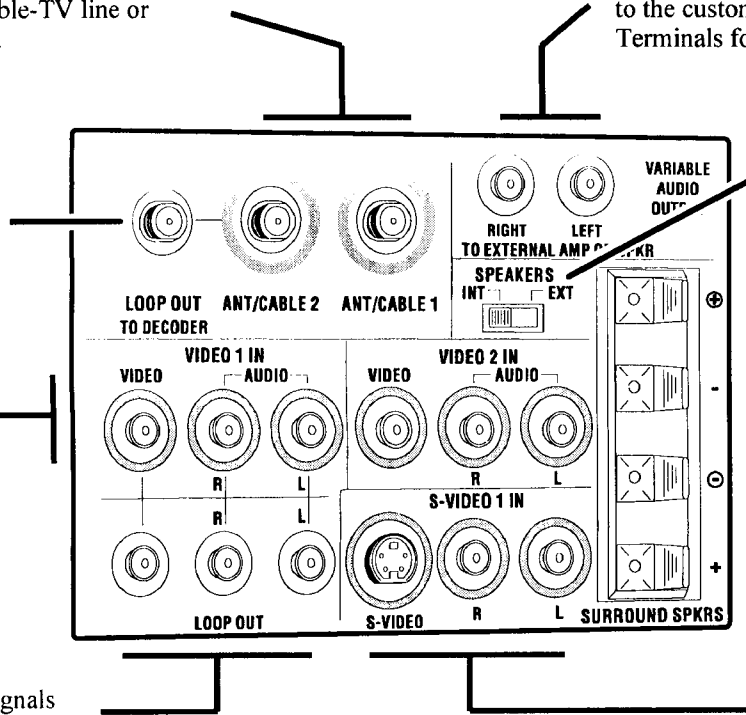

OTHER A/V JACKS ON TV (Some Models)

S-VIDEO 2 IN

Audio and video input from a Super-VHS VCR.

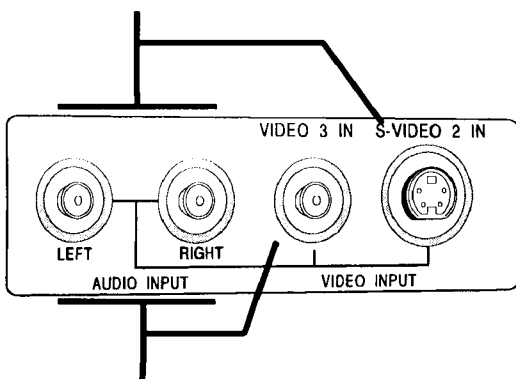

VIDEO 3 IN

Baseband audio and video input from a camcorder or other A/V component.

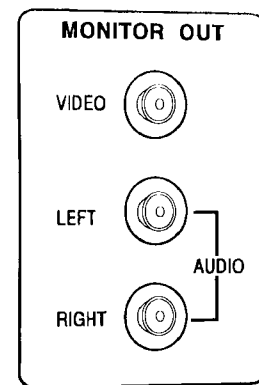

MONITOR OUT

Fixed-level baseband audio and video output to a monitor or other A/V component. Program currently being watched on your TV is provided at these jacks.

CONNECTIONS FOR YOUR TV

STEP 1. MAKE BASIC CONNECTION TO TV

Select the hook up that best fits your needs. See the following diagrams.

NOTE: The antenna may be connected to the ANT/CABLE 2 jack, however, connecting to the ANT/CABLE 1 jack may produce a better picture in weak signal areas.

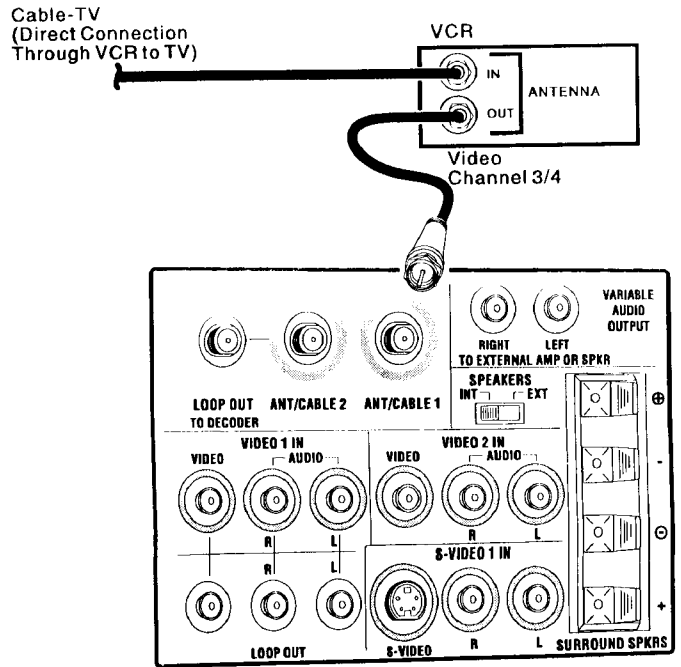
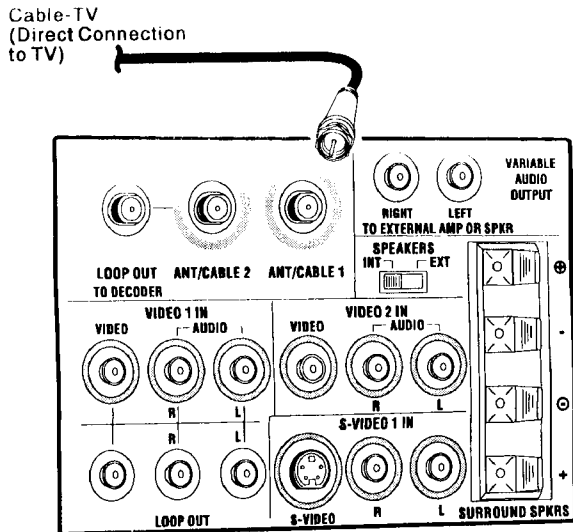
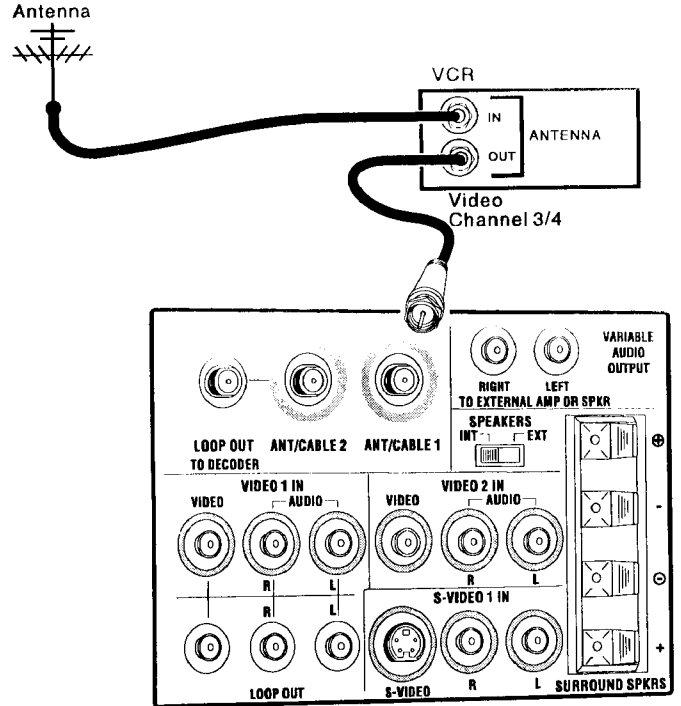
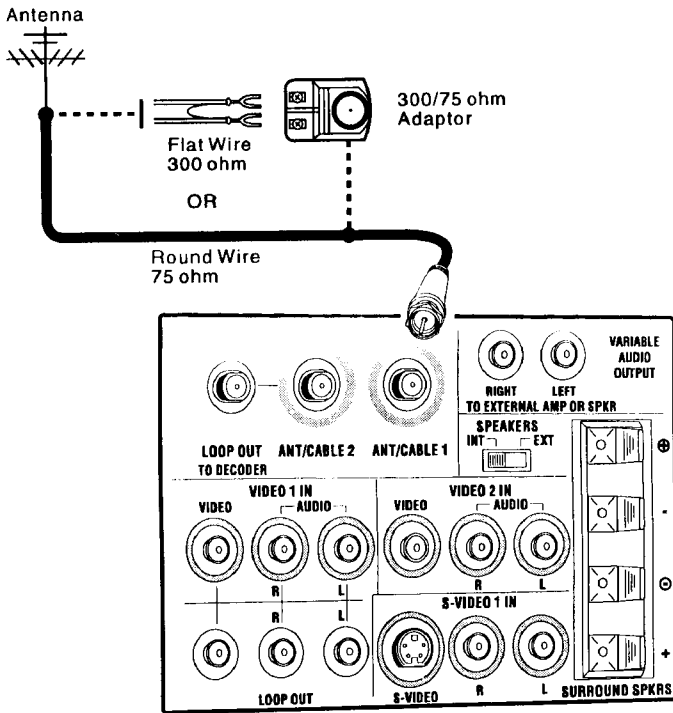

(continued on next page)

CONNECTIONS FOR YOUR TV

STEP 1. MAKE BASIC CONNECTION TO TV

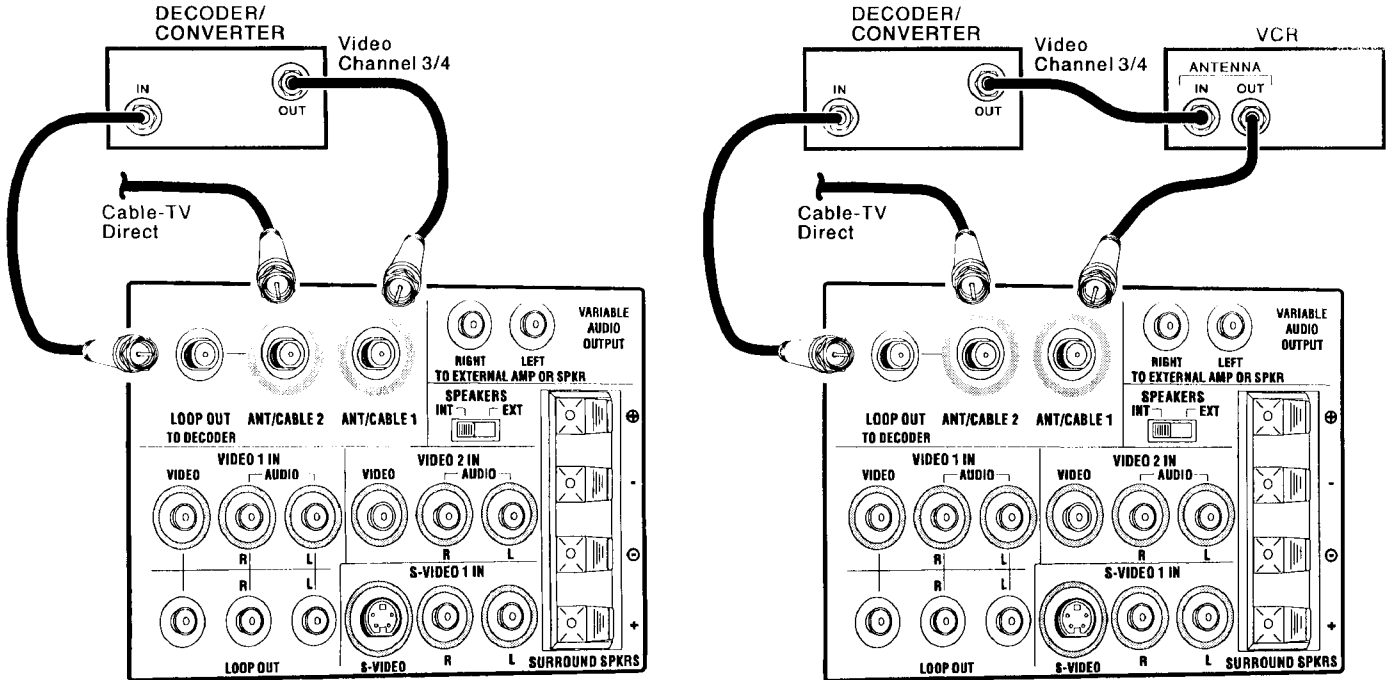

STEP 2. MAKE VCR CONNECTIONS TO TV

If you have a stereo VCR, you must make the A/V connections shown in order to hear stereo sound while playing a tape.

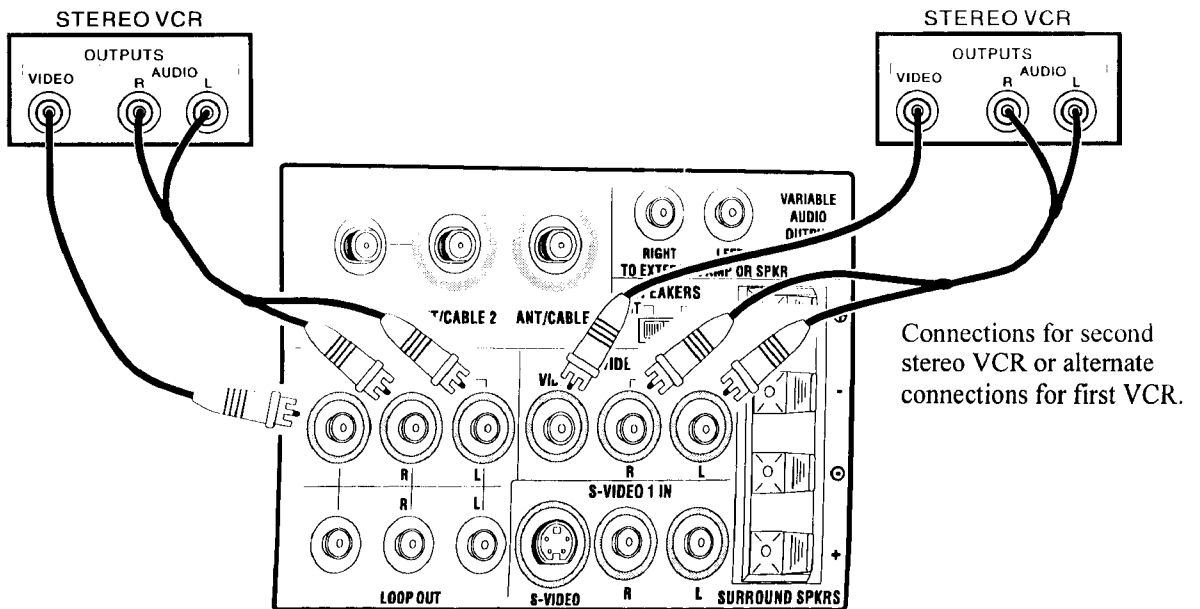

CONNECTIONS FOR YOUR TV

STEP 3. MAKE SUPER-VHS VCR CONNECTIONS TO TV

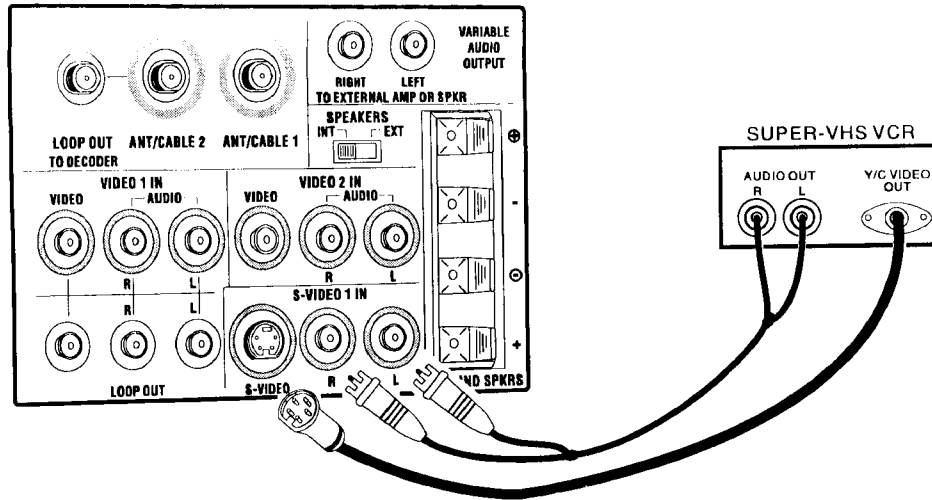

STEP 4. MAKE AV CONNECTIONS TO AUXILIARY A/V JACKS (VIDEO 3 IN OR S-VIDEO 2 IN)

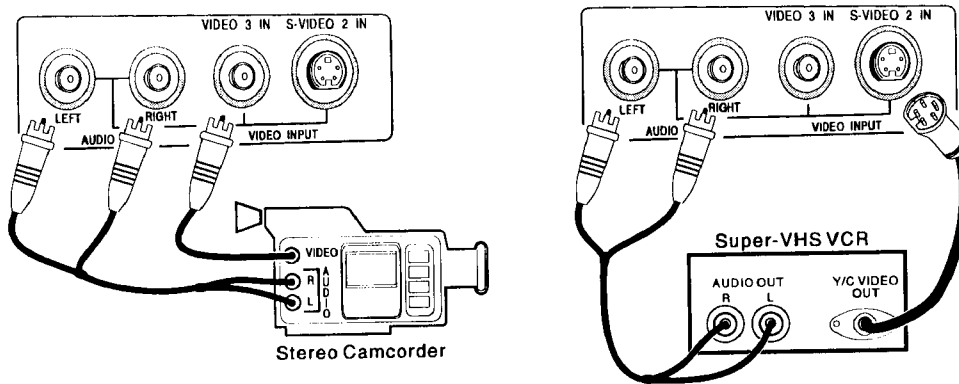

STEP 5. MAKE CONNECTIONS TO MONITOR OUT JACKS

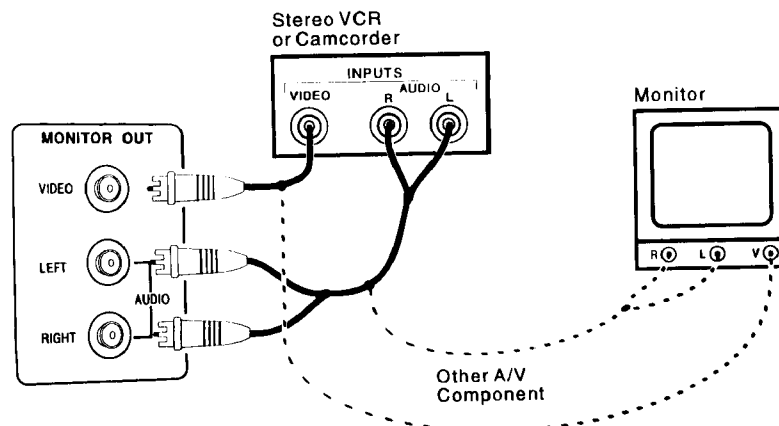

CONNECTIONS FOR YOUR TV

STEP 6. MAKE SURROUND SOUND CONNECTIONS TO TV

1. Mount and connect the optional surround sound speakers by following the instructions provided with the speakers.
2. Use the SURROUND option in the AUDIO Menu to adjust the volume of the surround speakers.
3. The level of the surround sound varies relative to the difference between the left- and right-channel stereo signals.

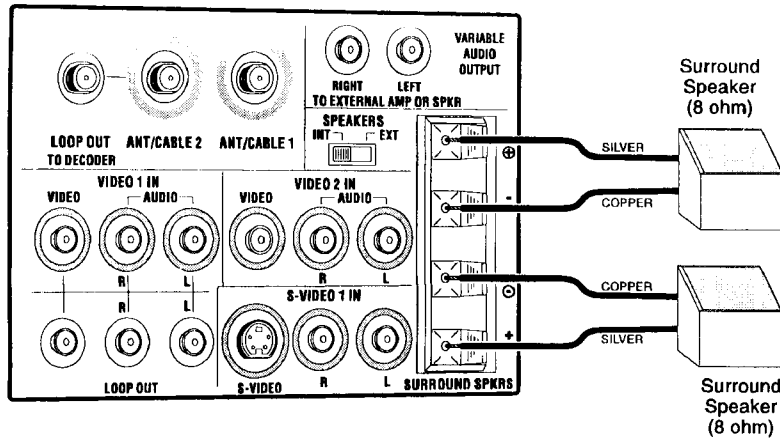

STEP 7. MAKE EXTERNAL SPEAKER CONNECTIONS TO TV

1. Place the SPEAKERS EXT/INT switch on the TV in the INT position.
2. Connect the two external speaker terminals.
3. Place the SPEAKERS EXT/INT switch on the TV in the EXT position.

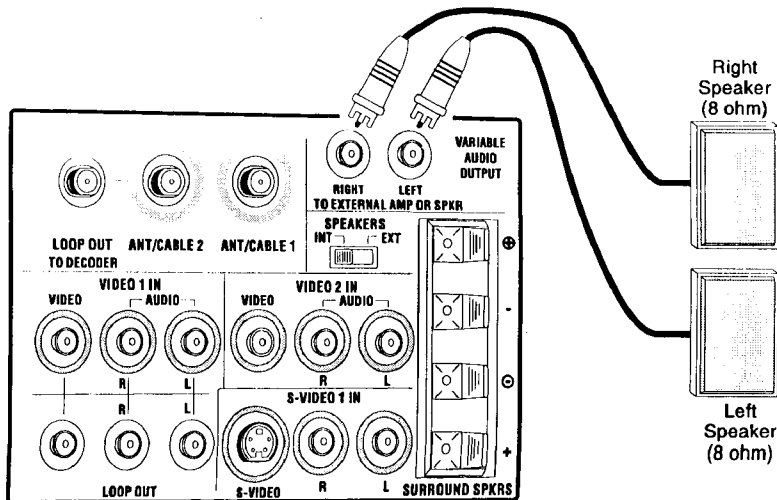

CONNECTIONS FOR YOUR TV

STEP 8. MAKE AUDIO CONNECTION TO STEREO AMPLIFIER

Using an External Amplifier with Speakers While the TV's Speakers are OFF.

1. Place the SPEAKERS EXT/INT switch on the TV in the INT position (TV's speakers are ON).
2. Turn the TV ON. Increase the volume level of the TV until the sound just starts to distort (sound bad).
3. Place the SPEAKERS EXT/INT switch on the TV in the EXT position (TV's speakers are OFF).
4. Turn the external audio amplifier ON. Adjust the volume level of the audio amplifier for the highest level you will need for your listening pleasure.
5. Adjust the volume level of the TV for the normal listening level as heard through the speakers of your audio amplifier.

Using an External Amplifier with Speakers While the TV's Speakers are ON.

1. Place the SPEAKERS EXT/INT switch on the TV in the INT position (TV's speakers are ON).
2. Turn the TV ON. Increase the volume level of the TV until the sound just starts to distort (sound bad).
3. Turn the external audio amplifier ON. Adjust the volume level of the audio amplifier for the highest level you will need for your listening pleasure.
4. Adjust the volume level of the TV for the normal listening level as heard through the speakers of the TV.

NOTE: If the volume of the internal TV speakers is set too low, you may hear undesirable noises through the speakers connected to your audio amplifier.

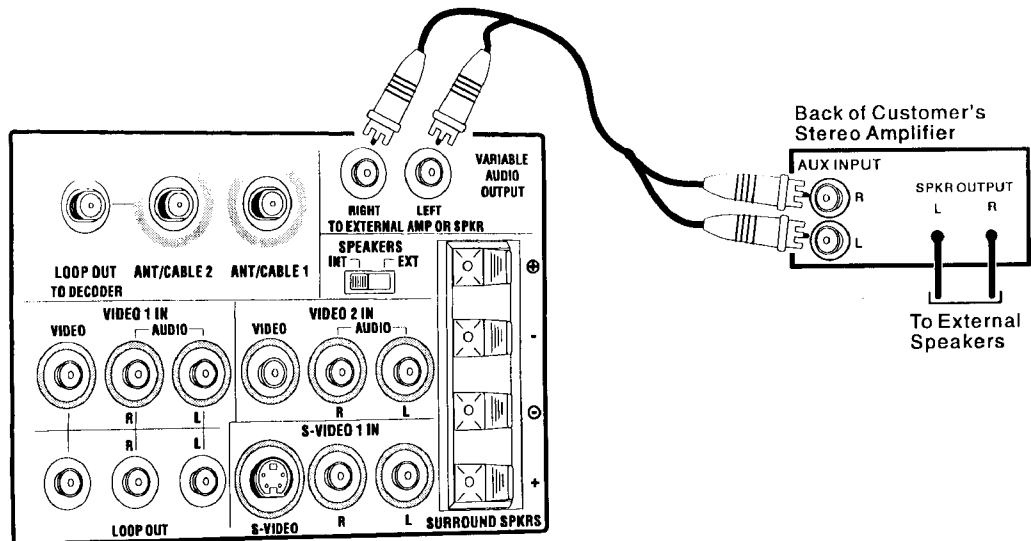

THE FIRST TIME YOU OPERATE YOUR TV

STEP 1. CONNECT THE POWER

- A. Plug your TV into an unswitched AC power source.
- B. Turn the TV ON by pressing OFF-ON.

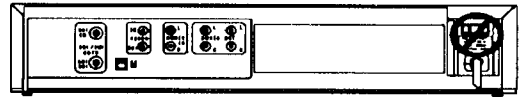

Do not plug TV into switched outlet
on cable-TV decoder or VCR

STEP 2. SELECT YOUR VIEWING SOURCE

A TV source refers to the equipment connected to the TV that supplies the picture and sound to your TV. You select the viewing source by using the SOURCE MENU.

To Access SOURCE MENU

1. Press SOURCE on the remote control to view the SOURCE MENU.
2. Press SOURCE repeatedly until the desired source is highlighted.
3. Press ENTER to return to normal viewing.

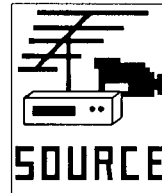

ANT/CABLE 1
ANT/CABLE 2
VIDEO 1
VIDEO 2
S-VIDEO 1
VIDEO 3 *
S-VIDEO 2 *

* Some models only.

NOTE: The antenna or cable must be connected to the TV before using AUTO PROGRAM to find available channels

STEP 3. USE AUTO PROGRAM

When your TV is first turned on, you will see the SETUP MENU with AUTO PROGRAM highlighted. AUTO PROGRAM finds all available channels from the selected source and stores them in the memory of the TV. To activate AUTO PROGRAM, press ADJUST (ADJ) Left/Right.

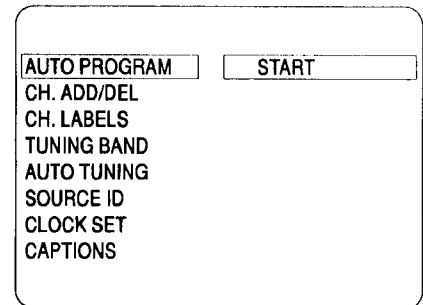

Setup Menu with Auto Program Highlighted

STEP 4. TIME FUNCTIONS

Set Clock In TV

1. Press Menu until the SETUP MENU is selected.
2. Press SELECT (SEL) to highlight CLOCK SET then use the number buttons on the remote to enter the correct time.
3. Select AM or PM using the TIMER key on the remote.
4. Press ENTER (ENT) to start the clock.

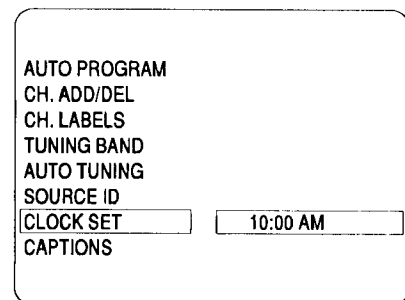

Selecting Clock Set

(continued on next page)

THE FIRST TIME YOU OPERATE YOUR TV

To Use Sleep Timer

1. Press **TIMER** to view the **SLEEP TIMER** screen.
2. Press **TIMER** repeatedly until you reach desired shut-off time.

One minute before the TV shuts off, the **GOOD NIGHT** display appears on the screen. At this time you have a choice of the following three actions.

1. Do nothing. The TV will shut off in one minute. The display will count off the remaining seconds.
2. Remove the **GOOD NIGHT** display by pressing **ENTER**. The TV will still shut off in one minute.
3. Delay the shut off by pressing **TIMER** to select a new shut-off time.

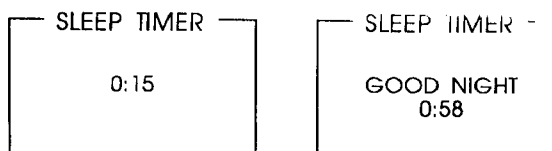

To Cancel the SLEEP TIMER

You can cancel the **SLEEP TIMER** by setting the **SLEEP TIMER** status to **OFF**.

NOTE: The **SLEEP TIMER** resets to **OFF** when you turn off the TV.

To Use ON/OFF Timer

1. Press **TIMER** and then **MENU** on the remote to view the **ON/OFF TIMER** screen.
2. Press **SELECT (SEL)** to highlight **ON TIME**. Use the number keys on the remote to enter the time for the TV to turn on. Press **TIMER** to choose **AM** or **PM**.
3. Press **SELECT (SEL)** to highlight **OFF TIME**. Use the number keys on the remote to enter the time for the TV to turn off. Press **TIMER** to choose **AM** or **PM**.

4. Press **SELECT (SEL)** to highlight **TIMER**. Use **ADJUST (ADJ)** on the remote to turn **TIMER ON** or **OFF**.

NOTE: A time must be set in either the **ON TIME** or **OFF TIME** before you can turn the **TIMER ON**.

5. Press **ENTER (ENT)** to return to normal viewing.

NOTE: The **ON/OFF Timer** can not be used until after the television's clock is set.

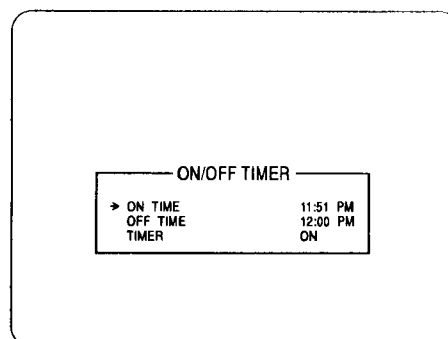

ON/OFF Timer

STEP 5. USE OTHER OPTIONS

You may want to use the following options:

- Program the channels accessed when using **CHANNEL Up/Down**. Refer to **CH. ADD/DEL** option for details.
- Add labels (such as **NBC** and **ABC**) to the **Channel/Time** display. Refer to **CH. LABELS** option for details.

REMOTE CONTROL MODEL SC3820

TV OPERATIONS

The following functions and operations apply to Zenith TV models built after 1981.

The remote control must be in the TV mode to operate your TV. Press MODE to select the TV mode. The TV indicator lights when you are in the TV mode.

MODE

Used to select the TV mode of operation.

TV

Lights when TV mode of operation is selected.

CC (Closed Captions)

Used to view closed captions broadcast with some television programs.

MENU, SELECT and ADJUST

Used with on-screen menus to see menu, select an option, and adjust that option.

Numbered Buttons

Used to select a TV channel.

ENTER

Used to view the Channel/Time Display or to remove any on-screen menu or display.

Point toward your TV.

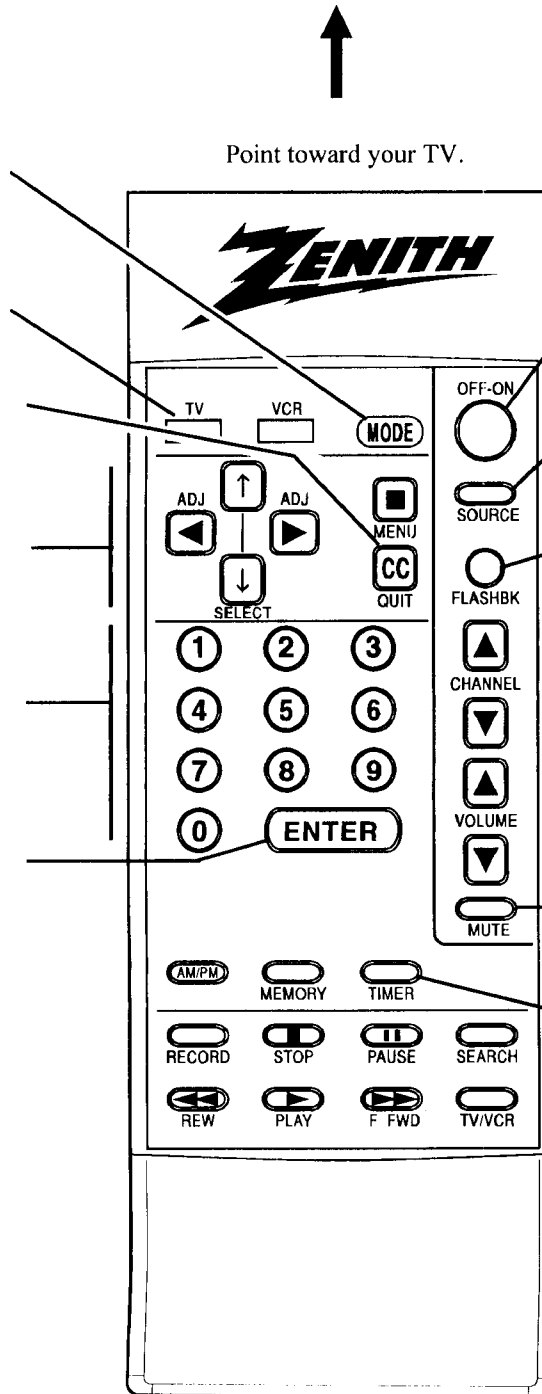

OFF/ON

Used to turn TV ON or OFF.

SOURCE

Used to display the menu of TV sources for some TVs. Press again to step through the source selections. On some TVs, press to select AUX (Auxiliary) channel.

FLASHBK (Flashback)

Used to return to the last TV channel you were watching.

CHANNEL Up/Down

Used to sequence through the TV channels.

VOLUME Up/Down

Used to adjust the TV's volume.

MUTE

Used to turn off sound while the picture remains. Press again to restore the sound.

TIMER

Used to activate the SLEEP TIMER. Press repeatedly to select desired turn-off time.

REMOTE CONTROL MODEL SC3820

VCR OPERATIONS

The following functions and operations apply to Zenith VCR models built after 1991.

For complete details on how to operate your Zenith VCR, refer to the operating guide supplied with it.

The remote control must be in the VCR mode to operate your VCR. Press MODE to select the VCR mode. The VCR indicator lights when you are in the VCR mode.



Point toward your VCR.

MODE

Used to select the VCR mode of operation.

VCR

Lights when VCR mode of operation is selected.

MENU, SELECT, ADJUST and QUIT

Used with on-screen menus and programming options of the VCR. See VCR operating guide for details.

Numbered Buttons

Used to select a TV channel through the VCR. Also, used to set the timer in the VCR, and to enter programming information.

ENTER

Used with the numbered buttons to select a TV channel through the VCR.

AM/PM

Used to set timer during programming.

MEMORY

Used to activate the COUNTER MEMORY feature.

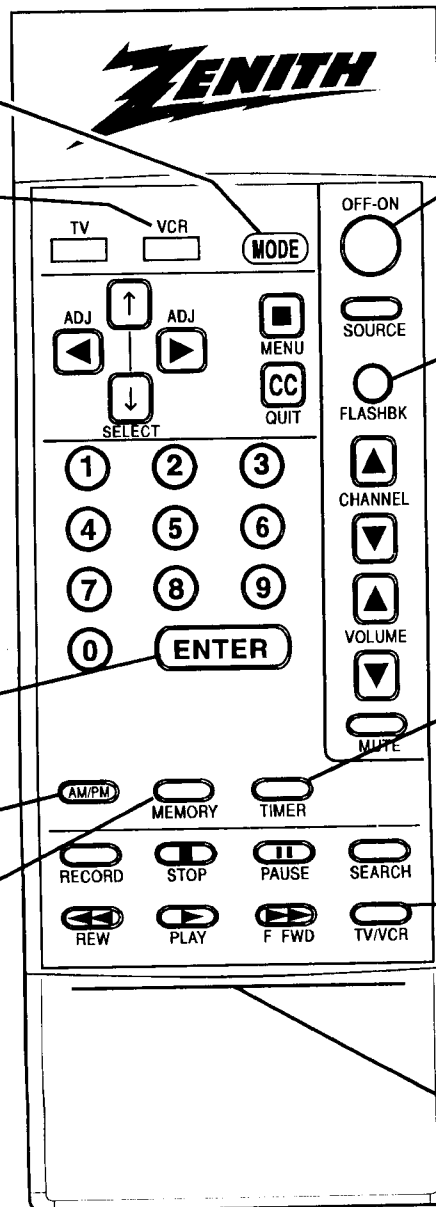

OFF/ON

Used to turn VCR ON or OFF.

FLASHBK (Flashback)

Used during VCR playback to view the channel tuned by the VCR.

CHANNEL Up/Down

Used to sequence through channels on the VCR.

TIMER

Activates TIME RECORD on some VCRs. See the VCR operating guide for details.

TV/VCR

Used to select the source of the programs seen on the TV. Switches the VCR between TV mode and VCR mode.

TV Mode: Channels are selected through the TV.

VCR Mode: Channels or tape operation are selected through the VCR.

RECORD, STOP, PAUSE, SEARCH, REW, PLAY and F FWD

Used for tape recording and playback functions. See the VCR operating guide for details.

REMOTE CONTROL MODEL SC3820

TV AND VCR OPERATIONAL NOTES

Some controls on the remote, like PLAY and VOLUME will always operate the VCR or the TV. Whether other keys operate the TV or the VCR depends on the mode of the remote control. For example, OFF-ON will turn the VCR ON and OFF while the remote control is in the VCR mode. It will turn the TV ON or OFF while the remote control is in the TV mode.

Some of the functions provided by this remote control may not be part of your TV and/or VCR. You will not be able to activate those functions even though there is a control button on the remote. For example, pressing TIMER provides direct access to the Sleep Timer on many TVs. If your TV does not have a Sleep Timer, pressing TIMER has no effect.

PREPARATION FOR USE

Batteries are provided with this remote, but you must install them before using the remote.

INSTALLING BATTERIES

When the effective operating range of your remote becomes noticeably shorter, replace the batteries with two (2) high quality, alkaline, size AAA batteries.

1. Remove the battery compartment cover, PUSH DOWN tab and PULL OUT from top.
2. Insert new batteries as indicated in the diagram inside the compartment.
3. Replace the cover by inserting the tab on the bottom of the cover into its housing. Snap the cover into position.

NOTES:

- Be careful not to place heavy objects on top of the remote control buttons. Prolonged accidental operation of the remote control will shorten battery life.
- If you do not use the remote control for a month or more, remove the batteries. Battery leakage can cause damage to the remote control.
- Zenith is not responsible for damage caused by such battery leakage.

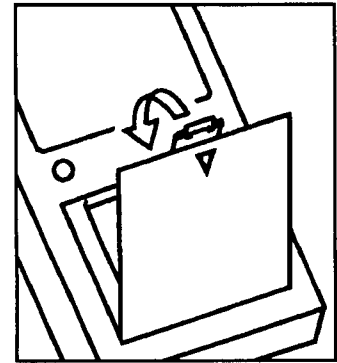
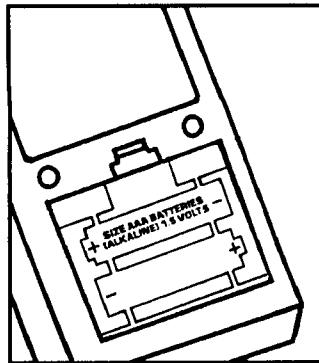
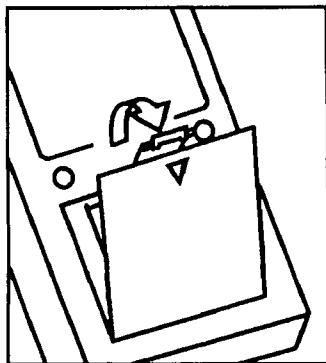

REMOTE CONTROL MODEL MBR3430

OPERATION

The multi-brand remote supplied with your new Zenith TV allows you to operate most models of infrared (IR) remote-controlled TVs, VCRs and cable-TV converters, even if they are all different brands.

Your multi-brand remote has already been programmed to operate your Zenith TV, a Zenith VCR and a Zenith cable-TV decoder. It must be "taught" to operate other brands. Refer to "Auto Find Mode" and "Programming Your Remote Control" for details.

CHOOSE THE OPERATING MODE

To operate your TV, VCR or CABLE-TV decoder, you must first choose the remote's mode of operation. To select the mode, press the MODE key until the desired indicator lights.

Some KEYS on the remote will always operate a particular appliance. For example, VOLUME always operates the TV volume and PLAY always operates the VCR. The function of other keys depends on the mode selected.

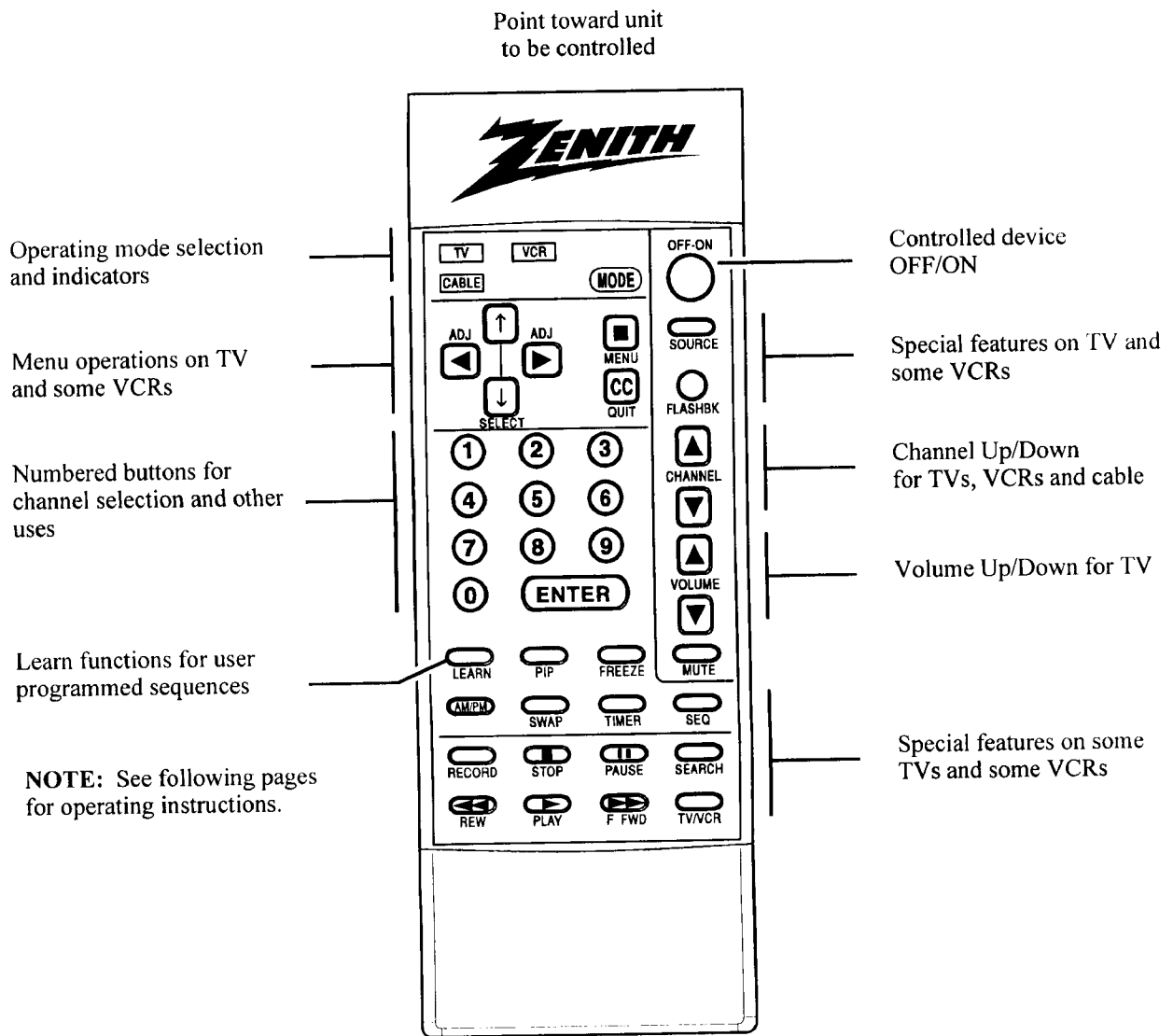

MBR3430

REMOTE CONTROL MODEL MBR3430

TV OPERATIONS

The following functions and operations apply to your Zenith TV. The remote control must be in the TV mode to operate your TV.

MODE

Used to select the TV mode of operation.

TV

Lights when TV mode of operation is selected.

CC (Closed Captions)

Used to view closed captions broadcast with some television programs.

MENU, SELECT and ADJUST

Used with on-screen menus to see menu, select an option, and adjust that option.

Numbered Buttons

Used to select a TV channel.

ENTER

Used to view the Channel/Time Display or to remove any on-screen menu or display.

LEARN

Used to program remote.

PIP

Used to activate Picture-In-Picture inset.

SWAP

Used to swap picture in PIP inset with the main television picture.

Point toward your TV.

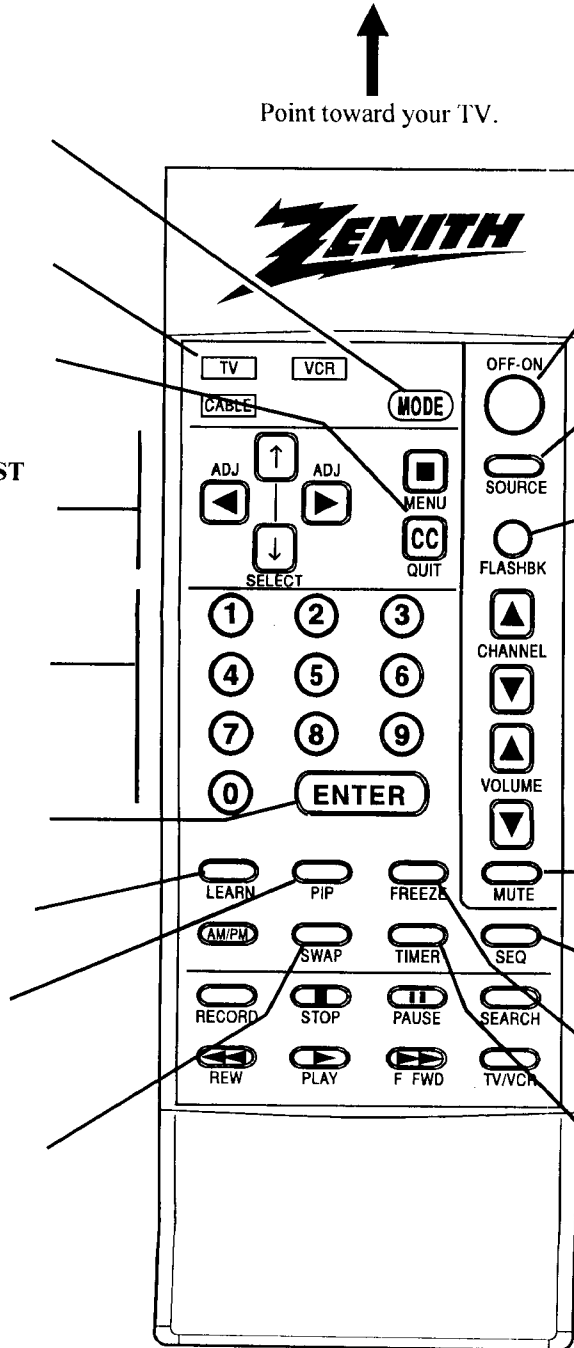

OFF/ON

Used to turn TV ON or OFF.

SOURCE

Used to display the menu of TV sources for some TVs. Press again to step through the source selections. On some TVs, press to select AUX (Auxiliary) channel.

FLASHBK (Flashback)

Used to return to the last TV channel you were watching.

CHANNEL Up/Down

Used to sequence through the TV channels.

VOLUME Up/Down

Used to adjust the TV's volume.

MUTE

Used to turn off sound while the picture remains. Press again to restore the sound.

SPATIAL EQUALIZATION (Seq)

Used to select SEQ audio mode on TVs equipped with SEQ feature.

FREEZE

Used to freeze the motion of the picture on the PIP inset.

TIMER

Used to activate the SLEEP TIMER. Press repeatedly to select desired turn-off time.

REMOTE CONTROL MODEL MBR3430

VCR OPERATIONS

The following functions and operations apply to Zenith VCR models built after 1988. The remote control must be in the VCR mode to operate your VCR.

The remote control supplied with your VCR may have keys not duplicated on the new remote. If these functions are desired, the original remote control will have to be used.

↑
Point toward your VCR.

MODE

Used to select the VCR mode of operation.

VCR

Lights when VCR mode of operation is selected.

MENU, SELECT, ADJUST and QUIT

Used with on-screen menus and programming options of the VCR. See VCR operating guide for details.

Numbered Buttons

Used to select a TV channel through the VCR. Also, used to set the timer in the VCR, and to enter programming information.

ENTER

Used with the numbered buttons to select a TV channel through the VCR.

AM/PM

Used to set timer during programming.

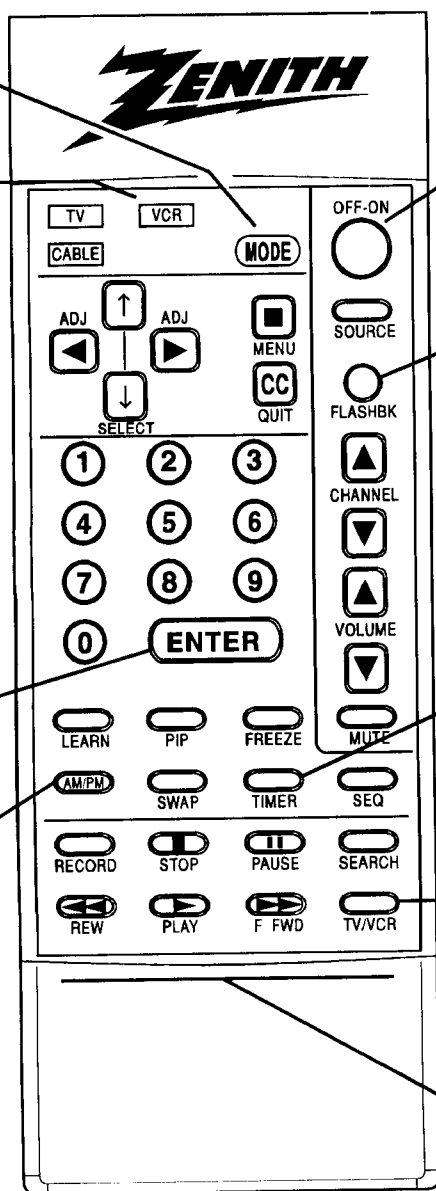

OFF/ON

Used to turn VCR ON or OFF.

FLASHBK (Flashback)

Used during VCR playback to view the channel tuned by the VCR.

CHANNEL Up/Down

Used to sequence through channels on the VCR.

TIMER

Activates TIME RECORD on some VCRs. See the VCR operating guide for details.

TV/VCR

Used to select the source of the programs seen on the TV. Switches the VCR between TV mode and VCR mode.

TV Mode: Channels are selected through the TV.
VCR Mode: Channels or tape operation are selected through the VCR.

RECORD, STOP, PAUSE, SEARCH, REW, PLAY and F FWD

Used for tape recording and playback functions. See the VCR operating guide for details.

REMOTE CONTROL MODEL MBR3430

CABLE-TV OPERATIONS

The following functions and operations apply to a Zenith cable-TV decoder. The remote control must be in the CABLE mode to operate your cable-TV decoder.

The remote control supplied with your cable-TV decoder may have keys not duplicated on the new remote. If these functions are desired, the original remote control will have to be used.

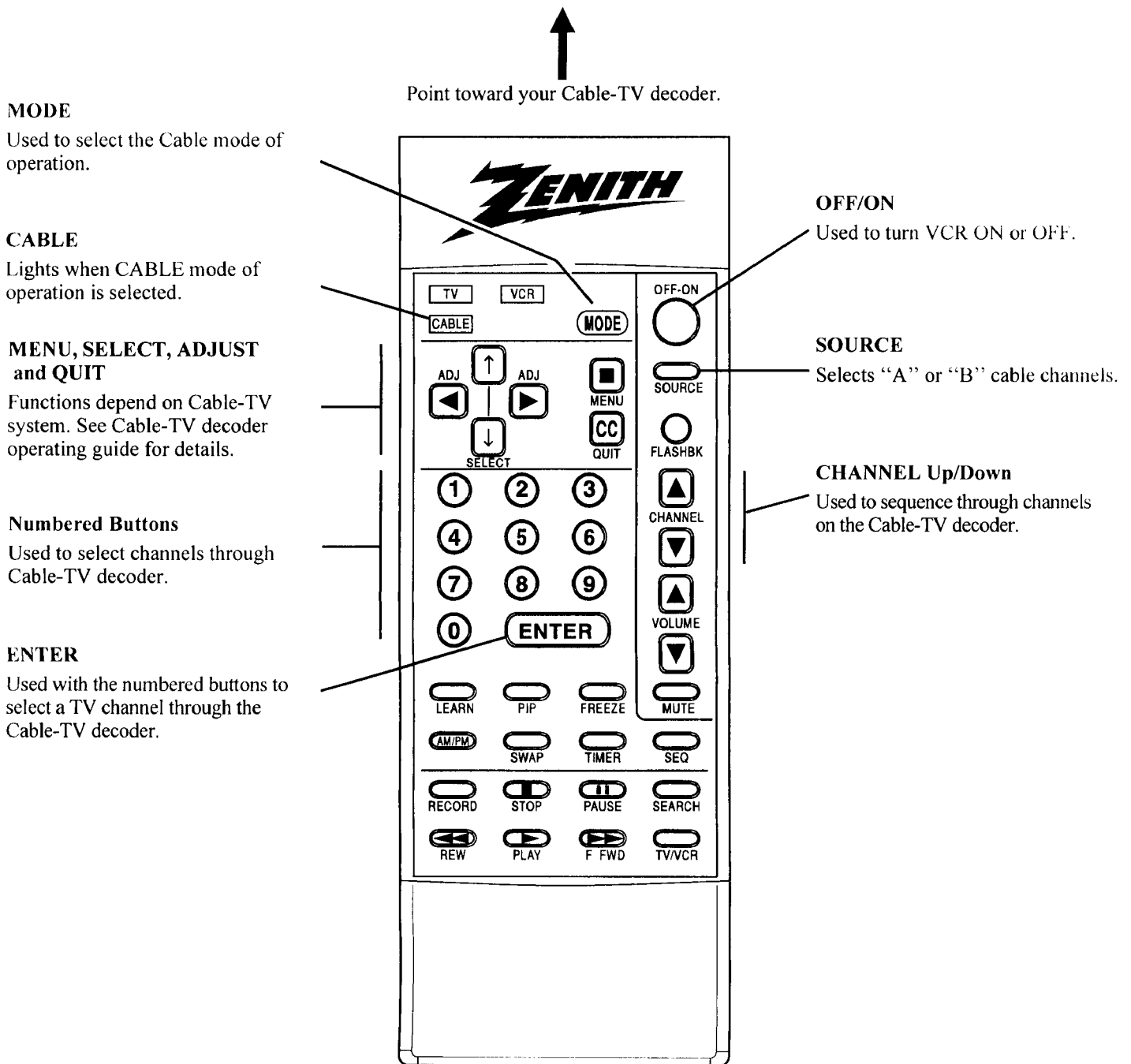

REMOTE CONTROL MODEL MBR3430

PREPARATION FOR USE

Batteries are provided with this remote, but you must install them before using the remote.

INSTALLING BATTERIES

When the effective operating range of your remote becomes noticeably shorter, replace the batteries with two high-quality, alkaline, size AAA batteries.

Zenith is not responsible for damage caused by battery leakage.

After installing new batteries, the remote control will set itself to Zenith brand codes, as follows: TV=101, VCR=201 and CABLE=301.

If you are going to operate equipment that uses different codes, the remote must be reprogrammed for those codes.

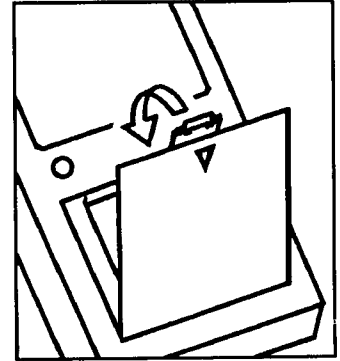
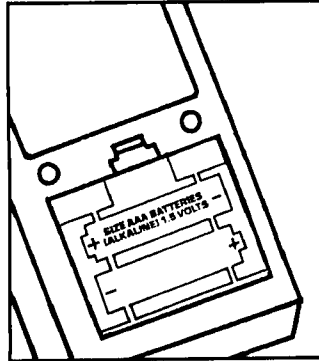
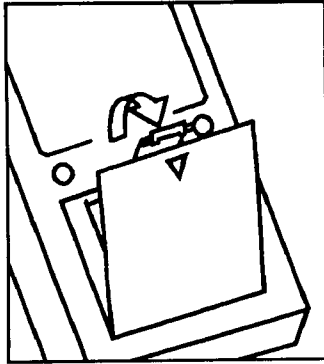

AUTO FIND MODE

Use Auto Find to automatically find the brand code needed to operate your equipment.

NOTE: If no button is pressed for 60 seconds or more during Auto Find, the remote will automatically exit Auto Find without storing any brand codes. (LEDs will flash 3 times upon exiting.)

1. Turn on the equipment you wish the remote to operate.
2. Press and hold LEARN until mode indicator lights (about 4 seconds).
3. Use MODE to select the mode you wish to program (TV, VCR or CABLE).
4. Enter "00" then press ENTER within 2 seconds. All four mode indicator lights will turn ON and then OFF, leaving the mode indicator light for the active mode ON.
5. Point remote towards the equipment.
6. Press and release OFF/ON on the remote about once every second, until the equipment turns OFF. **Press ENTER before pressing any other buttons.**

If you press OFF/ON again before pressing ENTER Auto Find will have to be repeated.

7. Try other buttons to see if they operate the equipment. If they do not, you may wish to reenter Auto Find and try to find another code. The remote will begin with codes starting from where it left off prior to exiting Auto Find.

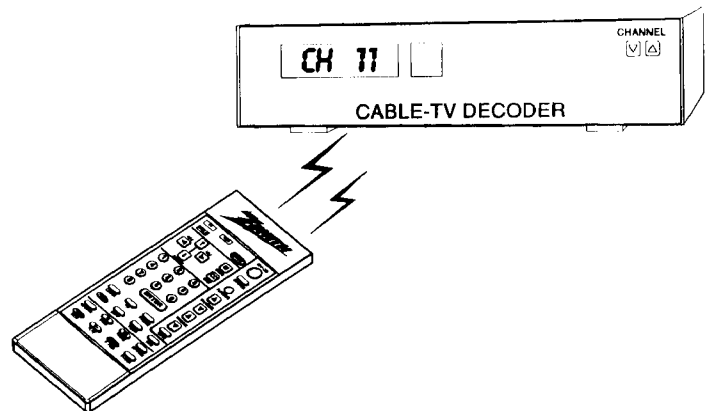

8. Repeat Auto Find for each piece of equipment you want your remote to operate. **NOTE:** Only one brand code can be programmed in each of the four modes.

If no brand code has been entered after searching through all brand codes in any mode, the remote will flash all four mode indicator lights in a chasing manner. Wait 60 seconds or press ENTER or LEARN to return to normal operation.

REMOTE CONTROL MODEL MBR3430

PROGRAMMING BRAND CODES

Introduction

Before using your new remote control, it must be programmed to recognize the brands of equipment it will be used to operate. If you are using a Zenith VHS VCR or a Zenith cable-TV decoder, the remote has already been programmed for you.

Find the code that corresponds to each brand and type of equipment you are going to operate. Refer to Tables 1, 2 and 3.

For example, if you were programming the remote for use with a Zenith TV, you would look for "Zenith" in "Table 1", and find code "101."

Write the brand codes for your equipment on the following lines.

TV CODE: _____

CABLE CODE: _____

VCR CODE: _____

1. Press MODE repeatedly to select the desired TV, VCR or CABLE operating mode for the remote.
2. Press LEARN for about 5 seconds until the MODE indicator lights for the selected TV, VCR or CABLE mode of operation.
3. Enter the proper brand code number for the equipment to be controlled.
4. Press LEARN. All three mode indicators should light briefly, then turn off to indicate the brand code has been programmed.
5. If all three mode indicators fail to light briefly, an error has occurred. Repeat Steps 1-4 to try again.
6. Repeat steps 1-4 to program the remote for the other equipment you are using.

NOTE: CABLE mode can be programmed to operate a second TV or second VCR, if desired.

When batteries are removed: It will be necessary to reprogram the proper VCR and cable-TV decoder codes.

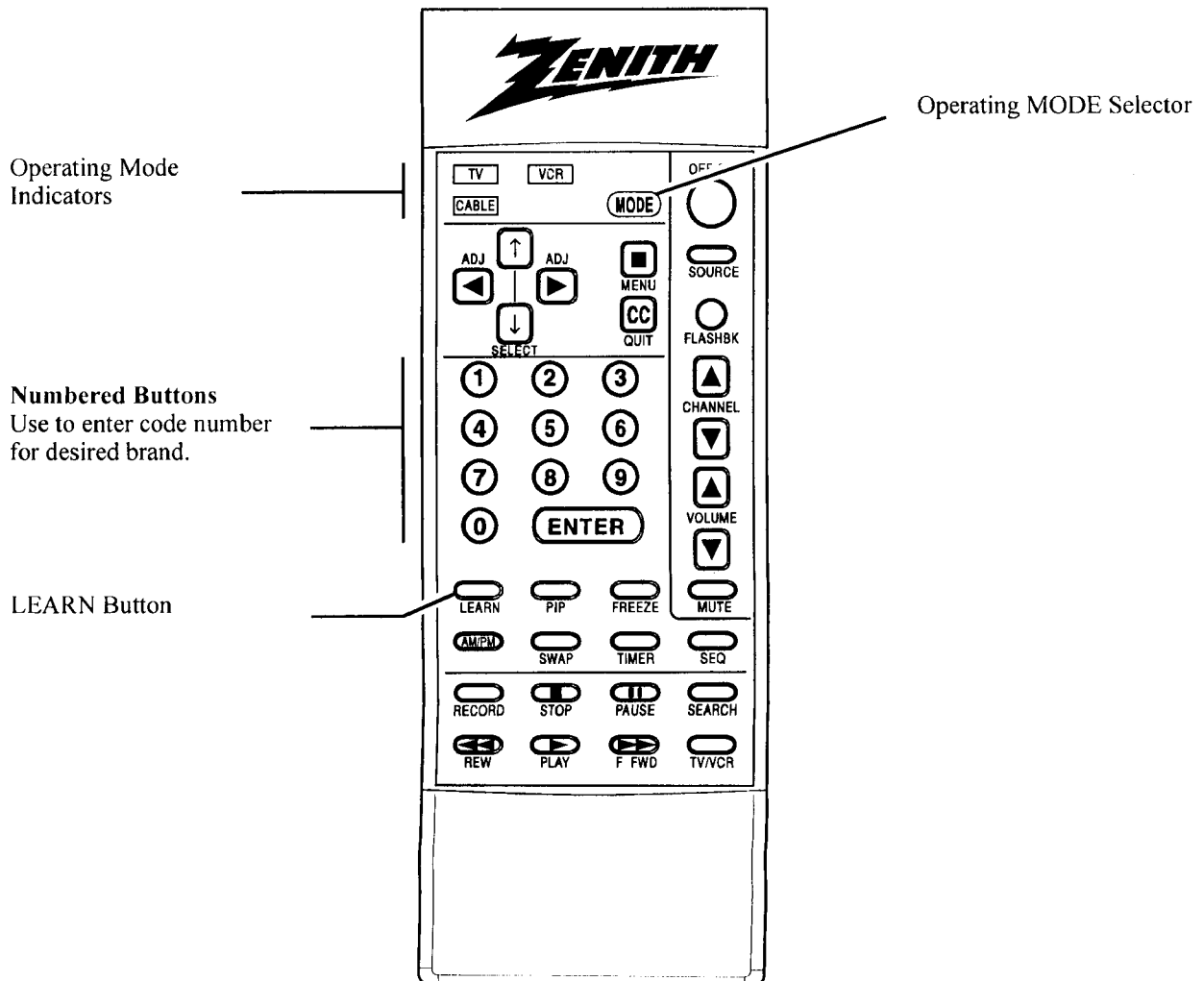

REMOTE CONTROL MODEL MBR3430

TV, VCR AND CABLE-TV OPERATING CODES

Table 1. TV Codes by Brand

TV Brand Name	Code	TV Brand Name	Code
Admiral	116	Montgomery Ward	119
Admiral	121	Montgomery Ward	121
Akai	104	Montgomery Ward	130
Amark	103	NEC	104
AOC	104	NEC	119
Bell & Howell	121	Panasonic	106
Centurion	119	Panasonic	107
Coronado	103	Philco	103
Curtis Mathes	116	Philco	104
Curtis Mathes	119	Philco	112
Curtis Mathes	121	Philco	113
Daytron	119	Philips	112
Emerson	103	Philips	113
Emerson	104	Pioneer	135
Emerson	123	Portland	103
Emerson	124	Quasar	106
Emerson	131	Quasar	107
Emerson	136	Realistic	105
Fisher	109	Realistic	123
Fisher	118	Realistic	124
General Electric	106	RCA	104
General Electric	107	RCA	116
General Electric	114	RCA	126
General Electric	116	Sampo	119
Goldstar	103	Samsung	103
Goldstar	104	Samsung	119
Goldstar	119	Samsung	134
Hitachi	102	Sanyo	108
Hitachi	103	Sanyo	109
Hitachi	129	Sanyo	118
JVC	125	Scott	119
JVC	132	Sears	103
J.C. Penney	104	Sears	108
J.C. Penney	110	Sears	109
J.C. Penney	114	Sears	110
J.C. Penney	117	Sears	111
J.C. Penney	119	Sears	118
KMC	103	Sears	134
KTV	103	Sharp	103
KTV	104	Sharp	105
Lodgenet	121	Sharp	122
Logik	121	Sharp	133
LXI	133	Sharp	137
LXI	137	Sony	115
Magnavox	103	Sylvania	112
Magnavox	112	Sylvania	113
Magnavox	113	Sylvania	117
Magnavox	119	Sylvania	119
Magnavox	127	Sylvania	127
Magnavox	128	Sylvania	128
Majestic	121	Tatung	106
Marantz	104	Teknika	103
Marantz	120	Teknika	112
Memorex	121	Teknika	121
MGA/Mitsubishi	104	Teknika	124
MGA/Mitsubishi	119	Telerent	103
MGA/Mitsubishi	120	Telerent	121
MGA/Mitsubishi	130	Toshiba	110
Montgomery Ward	103	Toshiba	111
Montgomery Ward	104	Toshiba	134
Montgomery Ward	105	Yorx	119
Montgomery Ward	113	Zenith	101
Montgomery Ward	114		

Table 2. VCR Codes by Brand

VCR Brand Name	Code	VCR Brand Name	Code
Akai	223	Pentax	215
Audio Dynamics	202	Philco	214
Audio Dynamics	218	Philips	214
Broksonic	221	Philips	227
Canon	214	Pioneer	210
Citizen	209	Pioneer	215
Craig	212	Pioneer Laser Disk	228
Curtis Mathes	214	Quasar	214
Curtis Mathes	216	RCA	215
DBX	202	RCA	216
DBX	218	RCA	220
Emerson	203	RCA	227
Emerson	221	Realistic	206
Emerson	223	Realistic	208
Emerson	226	Realistic	212
Emerson	233	Realistic	214
Emerson	235	Realistic	231
Fisher	211	Samsung	220
Fisher	212	Samsung	230
Fisher	213	Sanyo	206
Funai	231	Sanyo	212
General Electric	214	Scott	204
General Electric	216	Scott	205
General Electric	220	Scott	233
Goldstar	209	Sears	206
Hitachi	215	Sears	209
Instant Replay	214	Sears	211
Instant Replay	227	Sears	212
JVC	202	Sears	215
JVC	225	Sharp	208
J.C. Penney	214	Sony VHS	232
J.C. Penney	218	Sony Video 8	217
J.C. Penney	227	Sylvania	207
Kenwood	202	Sylvania	214
Magnavox	207	Sylvania	227
Magnavox	214	Symphonic	231
Marantz	207	Tashiko	209
Marantz	218	Tatung	202
Marta	209	Teac	202
Memorex	212	Teac	231
Memorex	214	Teknika	234
Memorex	231	Toshiba	205
MGA/Mitsubishi	204	Toshiba	215
MGA/Mitsubishi	222	Vector Research	204
Montgomery Ward	208	Vector Research	218
Montgomery Ward	214	Yamaha	202
Montgomery Ward	219	Yamaha	218
NEC	202	Zenith VHS	201
NEC	218	Zenith VHS	225
Panasonic	214	Zenith VHS	229

Table 3. Cable Decoder Codes by Brand

Cable Decoder Brand Name	Code	Cable Decoder Brand Name	Code
Drake Satellite	312	Pioneer	315
Drake Satellite	330	Regency	329
Gemini	305	Samsung	335
Gemini	331	Scientific Atlanta	316
General Instrument	305	Scientific Atlanta	323
General Instrument	306	Scientific Atlanta	336
Hamlin	302	Sprucer	
Hamlin	303	(Panasonic)	313
Jerrold	304	Standard	
Jerrold	307	Components	335
Jerrold	308	STS Satellite	324
Jerrold	309	Telecaption 4000	325
Jerrold	310	Tocom	317
Kale Vision	335	Tocom VIP	318
Macom	314	Toshiba	322
Macom	321	Toshiba Satellite	319
Macom Satellite	322	Zenith	301
Magnavox	334	Zenith	322
NSC	335	Zenith AV3000	327
Oak	311	Zenith Satellite	312
Oak	332	Zenith Satellite	330
Panasonic	313	Zenith Satellite	328
Panasonic	320	Zenith Laser Disk	326
Paragon (Zenith)	333		

QUICK REFERENCE TO ON-SCREEN MENUS

AVAILABLE MENUS

Your TV is icon and menu operated. That is, an icon is selected at the top of the TV screen and a menu of adjustment options appears.



AUTO PROGRAM
 CH. ADD/DEL
 CH. LABELS
 TUNING BAND
 AUTO TUNING
 SOURCE ID
 CLOCK SET
 CAPTIONS
 PROJO SETUP

Unhighlighted

Highlighted
 Menu for highlighted icon appears at left of TV screen.

SUMMARY OF MENU ITEMS



ANT/CABLE 1
ANT/CABLE 2
VIDEO 1
VIDEO 2
S-VIDEO 1
VIDEO 3 *
S-VIDEO 2 *

ANT/CABLE 1 or 2 : Either of these sources may be used for input from an antenna or a cable-TV line.

VIDEO 1 or 2 : Either of these sources may be used for input from a VCR.

S-VIDEO 1 : Use this source if a Super-VHS VCR is connected to your TV.

VIDEO 3 : Use this source if a camcorder is connected to your TV.

S-VIDEO 2 : Use this source if a second Super-VHS VCR is connected to your TV.

* Some models only.

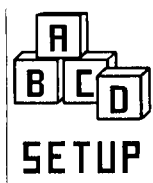

AUTO PROGRAM
 CH. ADD/DEL
 CH. LABELS
 TUNING BAND
 AUTO TUNING
 SOURCE ID
 CLOCK SET
 CAPTIONS
 PROJO SETUP

AUTO PROGRAM: Finds all available channels and stores them in the memory of the TV for use with CHANNEL Up/Down.

CH. ADD/DEL: Changes the list of active channels stored in memory so that only your favorite channels are selected when using CHANNEL Up/Down.

CH. LABELS: Adds a channel label or name to the channel/time display. For example, ABC may appear when this network channel is tuned.

TUNING BAND: Determines the operation of the channel selector inside the TV.

AUTO TUNING: Lets your TV compensate for variations in broadcast and cable-TV frequencies.

SOURCE ID: Lets you assign a relevant name to each input source.

CLOCK SET: Sets the TV's internal clock.

CAPTIONS: Displays closed captions (CC) or informational text when available.

PROJO SETUP: Adjusts the dynamic color convergence of the TV picture.

QUICK REFERENCE TO ON-SCREEN MENUS

SUMMARY OF MENU ITEMS



BASS
TREBLE
BALANCE
AUDIO
SEQ
SURROUND

BASS: Adjusts the BASS (low-frequency) level.

TREBLE: Adjusts the TREBLE (high-frequency) level.

BALANCE: Adjusts the BALANCE of sound between the left and right speakers for stereophonic programs.

AUDIO MODE: Allows for receiving a Second Audio Program (SAP), such as a program broadcast with two audio portions (typically two languages), or lets you select stereophonic (STEREO) or monaural (MONO) speaker operation.

SEQ: Turns on an enhanced stereo mode.

SURROUND: Adjusts Surround Sound volume when used with separately supplied Surround Sound speakers.

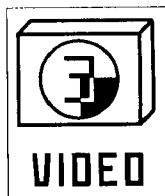

CONTRAST
BRIGHTNESS
COLOR
TINT
SHARPNESS
COLOR TEMP
VIDEO FILTER
AUTO FLESH
PICTURE PREF

CONTRAST: Adjusts the overall contrast and color level of the picture.

BRIGHTNESS: Adjusts the brightness level of black areas in the picture.

COLOR: Adjusts the intensity of the colors in the picture.

TINT: Adjusts the color of the flesh tones.

SHARPNESS: Adjusts the clarity of the edges of objects for the clearest possible picture.

COLOR TEMP: Changes the "color temperature" or picture white balance between cooler natural whites and warmer (red) colors.

VIDEO FILTER: Reduces video "noise" or interference in dark picture areas resulting in clearer overall pictures.

AUTO FLESH: Automatically maintains natural skin tones under changing scene and video source conditions.

PICTURE PREF: Lets you decide if you want to use your own CUSTOM video settings, the factory PRESET video settings, or the THEATER video settings for optimum viewing in low-light conditions.

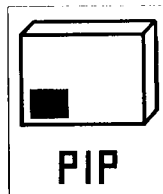

CH. GUIDE *
CH. REVIEW *
PIP SOURCE
PIP COLOR
PIP TINT
PIP SIZE

CH. GUIDE: Provides a visual review of all channels in the channel scan memory for the currently selected ANT/CABLE source.

CH. REVIEW: Provides a visual review of the last three (3) channels tuned on the TV.

PIP SOURCE: Lets you select the equipment that supplies the picture to the PIP inset.

PIP COLOR: Adjusts the intensity of the colors in the PIP inset.

PIP TINT: Adjusts the color of the flesh tones.

PIP SIZE: Lets you choose between seeing a larger or smaller PIP inset.

* Some models only.

QUICK REFERENCE TO ON-SCREEN MENUS

MENU OPERATION EXAMPLE

Press MENU repeatedly until the desired icon is highlighted and its menu is showing. This example shows choosing the SETUP MENU.

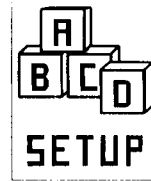
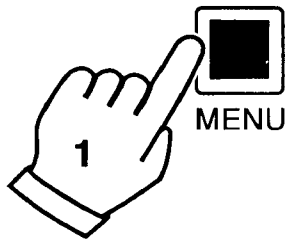

AUTO PROGRAM
CH. ADD/DEL
CH. LABELS
TUNING BAND
AUTO TUNING
SOURCE ID
CLOCK SET
CAPTIONS
PROJO SETUP

Press SELECT (SEL) Up/Down repeatedly until the desired option/feature is highlighted. This example shows choosing TUNING BAND.

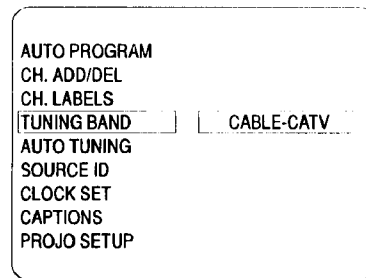
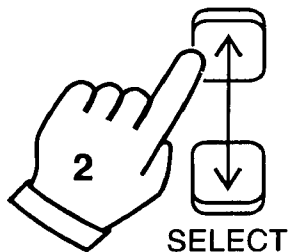

Press ADJUST (ADJ) Left/Right to adjust the option. This example shows the choices you have for TUNING BAND.

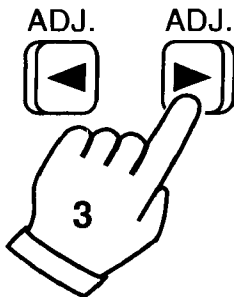

Tuning Band options are:

BROADCAST
CABLE-CATV
CABLE-HRC
CABLE-ICC

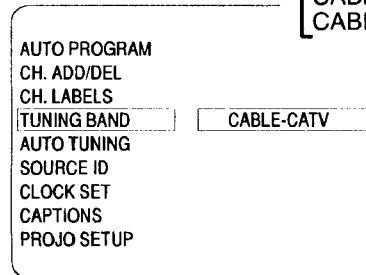

Press ENTER (ENT) or wait a few seconds and the TV will return automatically to normal operation.

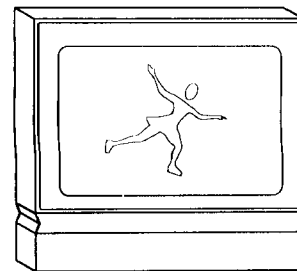
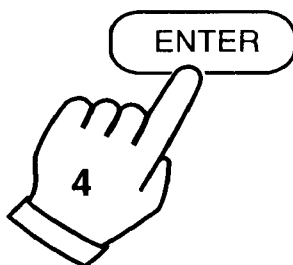

SOURCE MENU

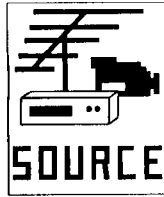

- ANT/CABLE 1
- ANT/CABLE 2
- VIDEO 1
- VIDEO 2
- S-VIDEO 1
- VIDEO 3 * Some models only
- S-VIDEO 2 *

Source Menu

SOURCE SELECTION

Purpose

The viewing "source" refers to the equipment that supplies the picture and sound to your TV. You select the viewing source by using the SOURCE MENU.

To Access the SOURCE MENU

1. Press SOURCE on the remote control to view the Menu icons with SOURCE already selected and its menu showing.
2. Press SOURCE repeatedly until the source you want is highlighted.
3. Press ENTER to return to normal viewing.

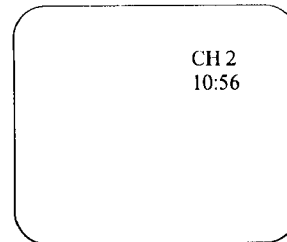

Channel/Time Display
For Antenna or Cable
Source

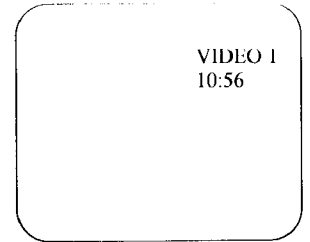

Channel/Time Display
For Video or S-Video
Source

SOURCE IDENTIFICATION

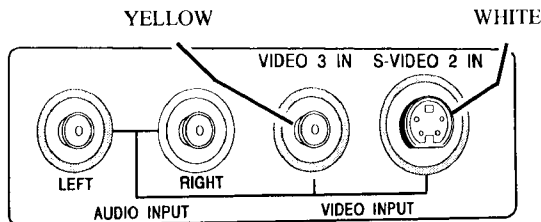

Auxiliary A/V Jacks

Selecting VIDEO 3 : Routes the auxiliary video source (such as a camcorder or VCR) to the TV for viewing. The video source must be connected to the corresponding VIDEO 3 jacks.

Selecting S-VIDEO 2: Routes the auxiliary Super-VHS VCR source to the TV for viewing. The Super-VHS VCR must be connected to the corresponding S-VIDEO 2 jacks.

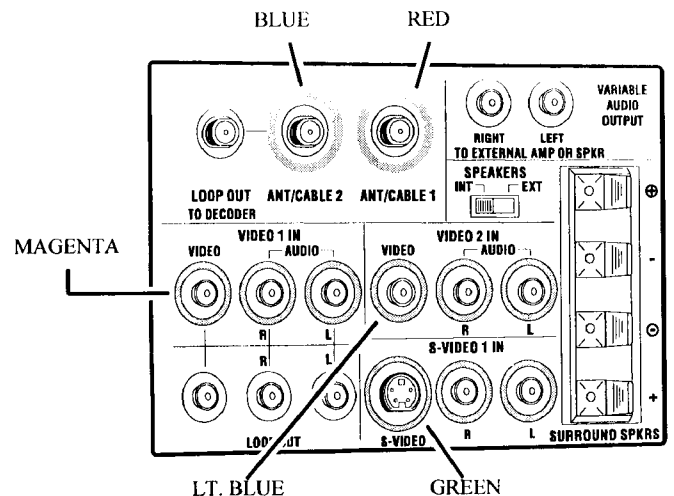

Connection Center on Back of TV

Selecting ANT/CABLE 1 or 2 : Routes the ANTENNA or cable-TV source to the TV for viewing. You see program material from whichever signal source is connected to the ANT/CABLE 1 or 2 jack.

Selecting VIDEO 1 or 2 : Routes the video source (such as a VCR or a Video Disc player) to the TV for viewing. The video source must be connected to the corresponding VIDEO 1/2 jacks.

Selecting S-VIDEO 1 : Routes the auxiliary Super-VHS VCR Source to the TV for viewing. The Super-VHS VCR must be connected to the corresponding input jacks.

SETUP MENU

To Access SETUP Menu

Refer to the "Using On-Screen Menus" section for details.

Before Using SETUP Menu

Connect and turn ON all external equipment, such as cable TV decoder, VCR, etc. before using any item on the SETUP Menu.

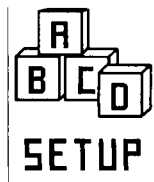

AUTO PROGRAM

CH. ADD/DEL
CH. LABELS
TUNING BAND
AUTO TUNING
SOURCE ID
CLOCK SET
CAPTIONS
PROJO SETUP

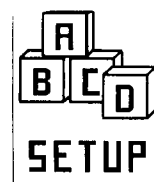

SOURCE ID
CLOCK SET
CAPTIONS
PROJO SETUP

Main Setup Menu

Setup Menu for Video and S-Video Sources

AUTO PROGRAM

Purpose

Finds all available channels and stores them in the memory of the TV for use by CHANNEL (CH) Up/Down.

Use AUTO PROGRAM only when you first install your TV, or when you permanently change the connections to the TV. For example, when you replace the antenna with a cable-TV system.

NOTE: AUTO PROGRAM can only be used with ANT/CABLE 1 or 2 Source selection.

To Use AUTO PROGRAM

1. Press ADJUST (ADJ) Left/Right to start Auto Program.
2. Use AUTO PROGRAM independently for each ANTENNA or CABLE signal source connected to your TV. Select one source by using the SOURCE MENU (ANT/CABLE 1 or 2) and use AUTO PROGRAM. When completed, select the other source and use AUTO PROGRAM again.

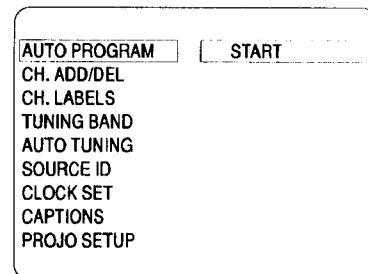

Selecting Auto Program

When Some Channels Are Not Found

AUTO PROGRAM finds only active channels and stores them in the favorite channel memory. You can add channels to those stored in memory by using CH. ADD/DEL.

CH. (Channel) ADD/DEL

Purpose

Lets you add channels to and remove channels from the channel scan. In this way you can customize the channels that are accessed through CHANNEL (CH) Up/Down.

NOTE: CH. ADD/DEL can only be used with ANT/CABLE 1 or 2 Source selection.

To Add a Channel to Scan Sequence

1. Press ADJUST (ADJ) Left/Right to view the channel add/delete screen.
2. Use the number buttons on the remote to enter the channel or use ADJUST (ADJ) Left/Right and SELECT Up/Down to move the highlight to the channel you wish to add.
3. Add the channel by pressing SOURCE until the display shows ADDED.

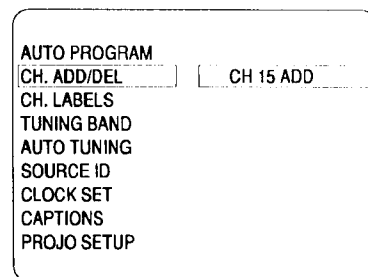

Selecting Ch. Add/Del

To Delete a Channel from Scan Sequence

1. Press ADJUST (ADJ) Left/Right to view the channel add/delete screen.
2. Use the number buttons on the remote to enter the channel or use ADJUST (ADJ) Left/Right and SELECT Up/Down to move the highlight to the channel you wish to delete.
3. Delete the channel by pressing SOURCE until the display shows DELETED.

(continued on next page)

SETUP MENU

Available channels for currently selected source.

Available channels are:

BROADCAST Band —
VHF 2 to 13, UHF 14 to 69

CATV, HRC and ICC Bands —
1 to 125

Use ADJUST Down to move highlight to higher numbers.

1 2 3 4 5 6
7 8 9 10 11 12
13 14 15 16 17 18
19 20 21 22 23 24
25 26 27 28 29 30
31 32 33 34 35 36
37 38 39 40 41 42
43 44 45 46 47 48
49 50 51 52 53 54
55 56 57 58 59 60
61 62 63 64 65 66
67 68 69 70 71 72
73 74 75 76 77 78
79 80 81 82 83 84
85 86 87 88 89 90

PRESS SOURCE TO CHANGE

ADDED

CH 15

Live view of currently selected channel.

Instructions
Channel Status: Added to or Deleted from channel scan.
Currently selected channel.

Channel Add/Delete Screen

CH. (Channel) LABELS

Purpose

Assigns a network label or “name” to the selected channels. If you choose the label “ABC” for channel 15, “ABC” appears in the Channel/Time display when channel 15 is selected for viewing.

NOTE: CH. LABELS can only be used with ANT/CABLE 1 or 2 Source selection.

A&E	ABC	ACTS	ADC	AMC	BET
BRAV	CA	CBC	CBN	CBS	CMTV
CNBC	CNN	COM	CSPN	CTN	CTV
DIS	DISC	E!	ENC	ESPN	ET
EWTN	FAM	FNN	FOX	GALA	HBO
HN	HSE	HSN	IC	INSP	LIFE
MAX	MEU	MMT	MTV	NBC	NICK
NOS	PBS	PLAY	PTL	QVC	RDS
REQ	SC	SCFI	SHOW	SIN	TBS
TBN	TELE	TLC	TMC	TNN	TNT
TRAV	TSN	TVA	TWN	USA	VC
VCR	VH1	VISN	VJN	WGN	WTBS
WWOR	YTV	---	---	---	---

Available Channel Labels

To Use CH. LABELS

1. Press ADJUST (ADJ) Left/Right to view the channel label screen.
2. Use ADJUST (ADJ) Left/Right and SELECT Up/Down to move the highlight to the LABEL you wish to assign to the current channel.
3. To label another channel, use CHANNEL Up/ Down, or the number keys on the remote control to select the channel number and repeat step 2.
4. To remove an assigned channel label, select the four dashes.

AUTO PROGRAM
CH. ADD/DEL
CH. LABELS CH 2 ABC
TUNING BAND
AUTO TUNING
SOURCE ID
CLOCK SET
CAPTIONS
PROJO SETUP

Selecting Ch. Labels

Available channel labels.

--- A&E ABC ACTS ADC
AMC BET BRAV CA CBC
CBN CBS CMTV CNBC CNN
COM CSPN CTN CTV DIS
DISC E! ENC ESPN ET
EWTN FAM FNN FOX GALA
HBO HN HSE HSN IC
INSP LIFE MAX MEU MMT
MTV NBC NICK NOS PBS
PLAY PTL QVC RDS REQ
SC SCFI SHOW SIN TBS
TBN TELE TLC TMC TNN
TNT TRAV TSN TVA TWN
USA VC VCR VH1 VISN
VJN WGN WTBS WWOR YTV

LABEL FOR

CH 15

Live view of currently selected channel.

Currently selected channel.

Channel Label Screen

SETUP MENU

TUNING BAND

Purpose

Allows for setting the TV channel selector (tuner) to match your antenna or cable-TV system.

If you are having difficulty tuning channels, the TUNING BAND may have to be set manually to match your viewing needs.

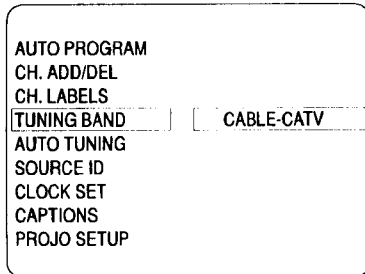

Selecting Tuning Band

NOTE: TUNING BAND can only be used with ANT/CABLE 1 or 2 Source selection.

To Use TUNING BAND

Press ADJUST (ADJ) Left/Right to select the tuning band that gives you the most channels:

- BROADCAST — is used for standard “over-the-air” broadcasts.
- CABLE — CATV is used for most standard cable-TV (CATV) systems.
- CABLE — HRC is used for cable-TV systems that use HRC (Harmonically Related Carrier).
- CABLE — ICC is used for cable-TV systems using ICC (Incremental Coherent Carrier).

Available Channels per Band

The channels that are available in the broadcast and cable tuning bands are shown below:

BROADCAST Band — VHF 2 to 13, UHF 14 to 69

CATV, HRC and ICC Bands — 1 to 125

AUTO TUNING

Purpose

Lets your TV compensate for variations in broadcast and cable-TV frequencies.

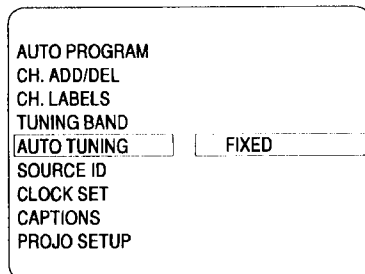

Selecting Auto Tuning

If you are having difficulty tuning channels, the AUTO TUNING may have to be set manually to match your viewing needs.

NOTE: AUTO TUNING can only be used with ANT/CABLE 1 or 2 Source selection.

To Use AUTO TUNING

Press ADJUST (ADJ) Left/Right to select the mode of operation that gives you the most channels:

- FIXED is used to receive “over-the-air” TV stations, and with many cable-TV systems.
- SEARCH is used only when the TV must search to find the frequency being received, such as when used with certain VCRs and video game controllers.

SOURCE ID

Purpose

Assigns a descriptive “name” to the input sources. For example, the VIDEO 1 source may be named VCR. “VCR” now appears in the source menu as a reminder that your VCR is connected to VIDEO 1 input jacks.

To Use SOURCE ID

1. Press ADJUST (ADJ) Left/Right to view the SOURCE ID screen.
2. Use SELECT Up/Down to select a SOURCE.
3. Use ADJUST (ADJ) Left/Right to select the desired name for the source.

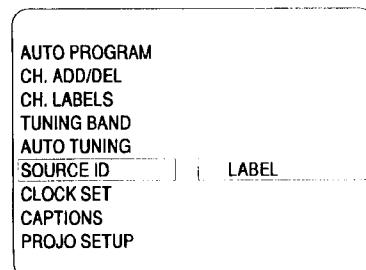

Selecting Source ID

(continued on next page)

SETUP MENU

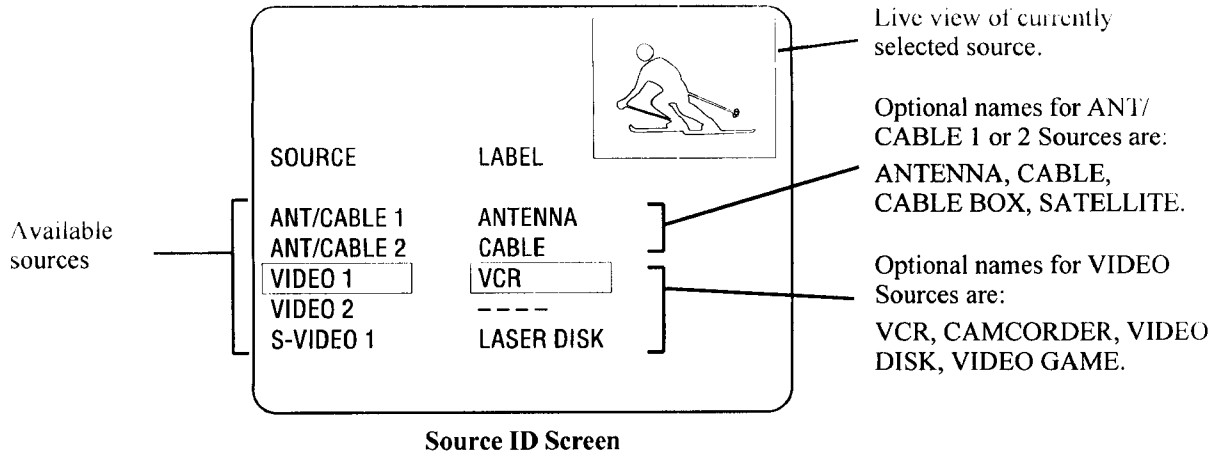

CLOCK SET

Purpose

Sets the clock in the TV to the correct time.

To Use CLOCK SET from Remote Control

To Use CLOCK SET from Control Panel

Use ADJUST (ADJ) Left/Right to set the time. Press ENTER (ENT) to start the clock.

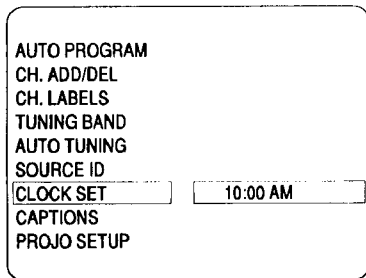

Selecting Clock Set

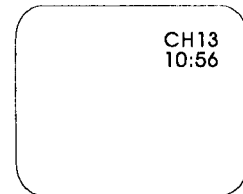

Channel/Time Display

Use the numbered buttons on the remote control to enter the current time. Press ENTER (ENT) to start the clock. Press TIMER to select AM or PM.

CAPTIONS

Purpose

Displays closed captions (CC) or informational text when available on the selected channel.

To Use CAPTIONS

Press ADJUST (ADJ) Left/Right to select desired mode of operation. Five different selections can be made: OFF, CAPTION 1, CAPTION 2, TEXT 1 or TEXT 2.

At the time of this writing, very little appears in any selection except CAPTION 1. Therefore you should choose CAPTION 1 and leave it in that selection unless you know there is something available in one of the other options. Once you make a selection, that selection is remembered until you change it.

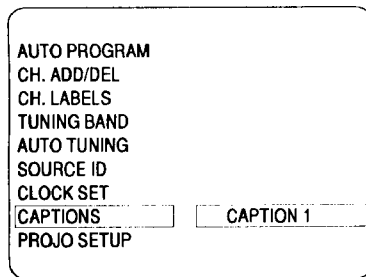

Selecting Captions



Typical Captions Display

Captions may be shown anywhere on the screen.

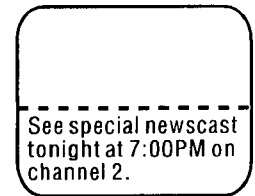

Typical Text Display

Fixed size text window. May be all black when no information is shown.

SETUP MENU

PROJO SETUP

Purpose

Lets you verify and adjust, if needed, the dynamic color convergence of the TV picture.

If you move your TV from its original location, or if after time, you notice color “fringes” around objects in the picture, you may want to realign the colors by adjusting the convergence as described in the following steps.

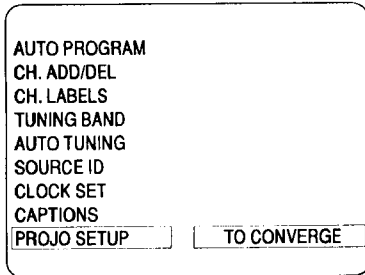

Selecting Projo Setup

To Use PROJO SETUP

1. Press ADJUST (ADJ) Left/Right to view the convergence lines.
If the display appears as four intersecting lines, all white in color, no adjustment is necessary.
If there are more than four lines, each a different color, you must adjust the convergence.
2. Use SOURCE key to select the Red reference color.
3. Use the SELECT and ADJUST arrow keys (Up, Down, Left and Right) to adjust the Red lines until they are on top of the Green lines.
4. Use SOURCE key to select the Blue reference color.
5. Use the SELECT and ADJUST arrow keys (Up, Down, Left and Right) to adjust the Blue lines until they are on top of the other lines. All lines should now be white.

PRESS SOURCE TO SELECT COLOR
PRESS ARROW KEYS TO CONVERGE

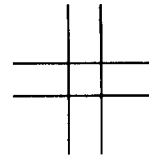

Correct Convergence

PRESS SOURCE TO SELECT COLOR
PRESS ARROW KEYS TO CONVERGE

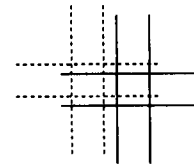

Incorrect Convergence

AUDIO MENU



BASS
TREBLE
BALANCE
AUDIO
SEQ
SURROUND

BASS	Adjusts the BASS (low-frequency) level.
TREBLE	Adjusts the TREBLE (high-frequency) level.
BALANCE	Adjusts the balance of sound between the left and right speakers for stereo programs.
AUDIO (AUDIO mode options are not available while using a VIDEO or S-VIDEO source. The audio received from these sources are assumed to be stereo.)	Allows you to select STEREO, MONO or 2ND AUDIO/SAP speaker operation. STEREO: Directs the sound to the left and right speakers as supplied by the program source (broadcast TV, VCR, etc.) MONO: Directs the same sound to both left and right speakers even if the source being received is in stereo. 2ND AUDIO/SAP: Directs the sound for the Second Audio Program to both the left and right speakers. SAP sound is always monaural. If the SAP signal ends, the audio defaults to either stereo or mono depending on the audio being received.
SEQ (Spatial Equalization)	Improves tonal balance and increases apparent stereo separation to produce a spacious and more tonal sound. SEQ is only available if a stereo signal is being received and STEREO is either selected using the AUDIO option or selected by default.
SURROUND	Adjusts the level of Surround Sound provided to the optional surround sound speakers. Surround Sound is only available if a surround encoded stereo signal is being received and STEREO is either selected using the AUDIO option or selected by default.

To Access AUDIO MENU

Refer to the "Quick Reference to On-Screen Menus" section for details.

NOTE: All adjustments on the AUDIO MENU are optional. You do not have to use these features in order to use your TV.

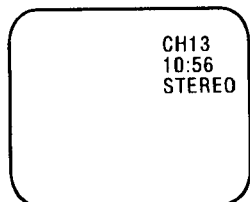

Audio Mode Shown in Channel/Time Display

STEREO is selected and a stereo signal is being received. You will hear stereo sound.

To Adjust BASS, TREBLE, BALANCE and SURROUND

Press ADJUST (ADJ) Left/Right until the most pleasing sound is heard.

To Use AUDIO Mode Options

Press ADJUST (ADJ) Left/Right to select desired option.

We recommend that you use the STEREO option. The TV will switch automatically between the STEREO and MONO modes dependent on the signal being received.

If you prefer SAP, use the 2ND AUDIO/SAP option. On those stations which broadcast two audio portions, you will hear the SAP (usually a second language). When the SAP broadcast ends, the TV switches automatically between STEREO and MONO modes. The TV switches back to 2ND AUDIO/SAP when the SAP broadcast resumes.

VIDEO MENU

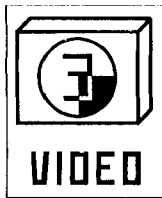

- CONTRAST
- BRIGHTNESS
- COLOR
- TINT
- SHARPNESS
- COLOR TEMP
- VIDEO FILTER
- AUTO FLESH
- PICTURE PREF

CONTRAST	Adjusts the overall contrast and color level of the picture.
BRIGHTNESS	Adjusts the brightness level of black areas in the picture.
COLOR	Adjusts the intensity of the colors in the picture.
TINT	Adjusts the color of the flesh tones, where G is Green and R is Red.
SHARPNESS	Adjusts the clarity of the edges of objects for the clearest picture quality.
COLOR TEMP	Changes the “color temperature” or picture white balance between cooler natural whites and warmer (red) colors.
VIDEO FILTER	Reduces video “noise” or interference in dark picture areas resulting in clearer overall pictures.
AUTO FLESH	Automatically maintains natural skin tones under changing scene and video source conditions.
PICTURE PREF. (Preference)	Lets you decide if you want to use your own CUSTOM video settings, the factory PRESET video settings, or the factory preset THEATER video settings for low light conditions.

To Access VIDEO Menu

Refer to the “Using On-Screen Menus” section for details.

Optional Adjustments

All adjustments on the VIDEO MENUS are optional. You do not have to use these features in order to use your TV.

To Use Video Settings

1. Select video option to be adjusted.
2. Press ADJUST (ADJ) Left/Right until the most pleasing picture is seen.

To Use PICTURE PREF. (Preference)

Press ADJUST (ADJ) Left/Right to select status.

If either the PRESET or THEATER setting is selected, any adjustment made to the VIDEO Menu options automatically changes the PICTURE PREF. setting to custom, and saves your current video settings in the CUSTOM mode.

PIP MENU

To Access PIP Menu

Refer to the "Using On-Screen Menus" section for details.

NOTE: Selecting the PIP Menu does not "activate" PIP. However, a PIP inset will appear during menu operation to show the effect of any setting changes.

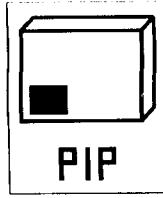

CH. GUIDE *
CH. REVIEW *
PIP SOURCE
PIP COLOR
PIP TINT
PIP SIZE

Some models only

CH. (Channel) GUIDE

Purpose

Provides a visual review of all channels in the channel scan memory for the currently selected ANT/CABLE source.

To Use CH. GUIDE

1. Press ADJUST (ADJ) Left/Right to start Ch. Guide.
2. The TV will show small PIP-like views of all channels in the channel scan from the lowest channel number to the highest.
3. Tune to a desired channel by pressing ENTER (ENT) while the picture in the PIP-like inset is active, or enter the channel number using the number keys on the remote.
4. Press MENU to return to the PIP Menu.

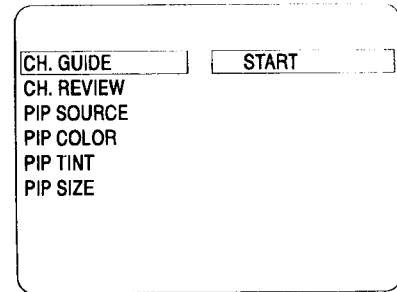

Selecting Ch. Guide

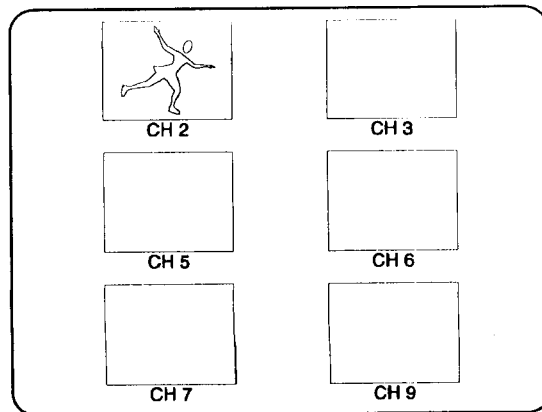

Ch. Guide Screen

PIP MENU

CH. (Channel) REVIEW

Purpose

Provides a visual review of the last three (3) channels tuned on the TV.

To Use Ch. Review

1. Press ADJUST (ADJ) Left/Right to start Ch. Review.
2. The TV will show small PIP-like views of the last three channels that were tuned.
3. Tune to a desired channel by pressing ENTER (ENT) while the picture in the PIP-like inset is active, or enter the channel number using the number keys on the remote.
4. Press MENU to return to the PIP Menu.

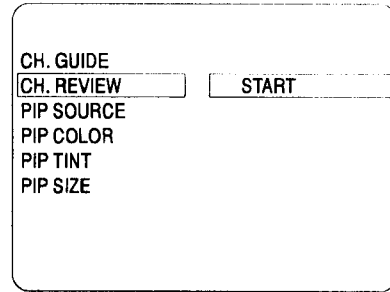

Selecting Ch. Review

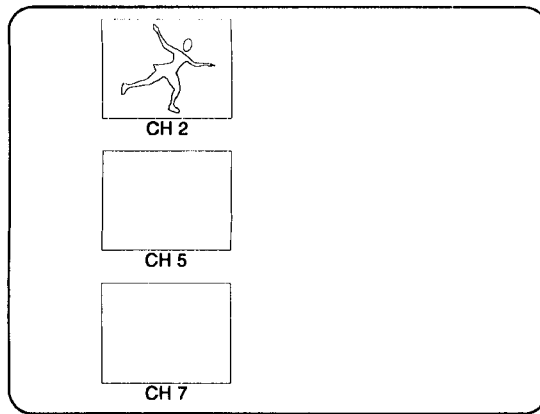

Ch. Review Screen

PIP SOURCE

Purpose

Lets you select the equipment that supplies the picture to the PIP inset.

To Use PIP SOURCE

Press ADJUST (ADJ) Left/Right to toggle through your source options.

NOTE: If you “named” your sources (see SOURCE ID in the SETUP MENU section), these names will appear when toggling through the PIP SOURCE options.

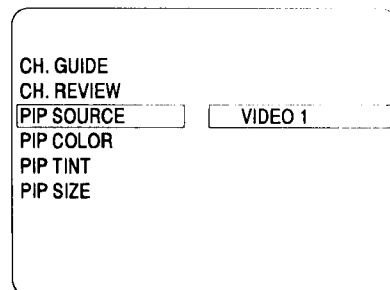

Selecting PIP Source

PIP MENU

PIP COLOR

Purpose

Adjusts the intensity of the colors in the PIP inset.

To Use PIP COLOR

Press ADJUST (ADJ) Left/Right to decrease or increase the intensity of colors in the PIP inset.

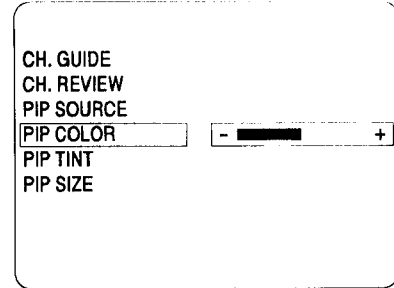

Selecting PIP Color

PIP TINT

Purpose

Adjusts the color of the flesh tones.

To Use PIP TINT

If flesh tones are too red or purple, press ADJUST (ADJ) Left until you achieve the desired flesh tone.

If flesh tones are too green or have a greenish TINT, press ADJUST (ADJ) Right until you achieve the desired flesh tone.

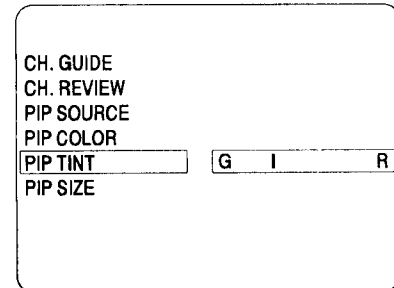

Selecting PIP Tint

PIP SIZE

Purpose

Lets you choose between seeing a larger or smaller PIP inset.

To Use PIP SIZE

Press ADJUST (ADJ) Left/Right to select either SMALLER or LARGER.

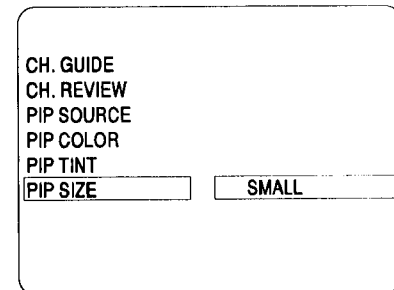

Selecting PIP Size

PIP OPERATION AND CONNECTIONS

Option 2: Antenna or Direct Cable Connection Loop Out

This illustration shows the basic connection of your TV to a stereo VCR. Using this connection, you are capable of the following operation:

- You may select ANT/CABLE 2 for main picture source to view channels tuned by the TV's channel selector. Simultaneously, you may select VIDEO 1 for PIP source to view — in the PIP inset — a tape playing in the VCR or ANT/CABLE 1 to view a different channel tuned by the VCR's channel selector. (VCR's TV/VCR button must be set to TV and TV must be tuned to channel 3 or 4.)

- Sources may also be swapped: VIDEO 1 may be the main picture and ANT/CABLE 1 the PIP inset; or ANT/CABLE 2 may be the main picture and ANT/CABLE 1 the PIP inset.

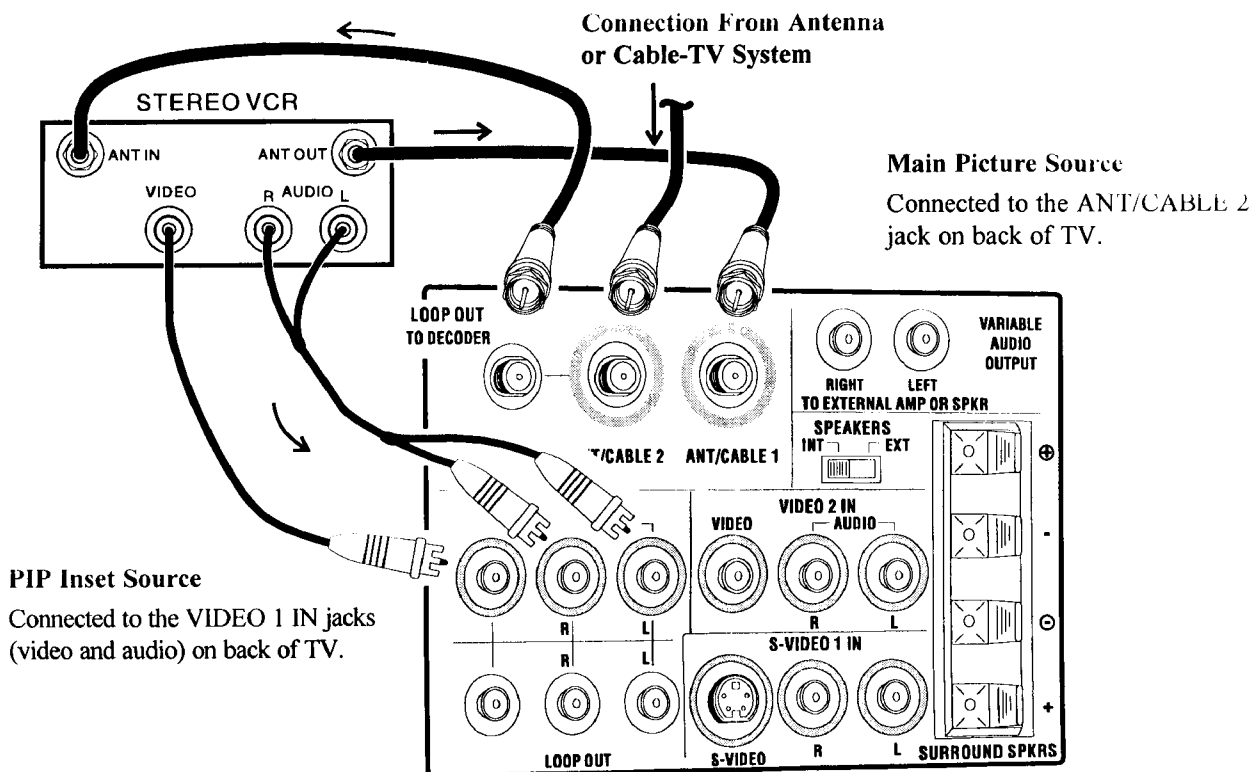

Option 2: Antenna or Direct Cable Connection Loop Out

PIP OPERATION AND CONNECTIONS

To Select Main Picture Source

The source for the main picture can be either ANT/CABLE 1 or 2 connections, or any of the VIDEO connections. The following example selects ANT/CABLE 1 for normal television viewing, which is the most common setup.

1. Select TV mode of operation for the remote control.
2. Press SOURCE on the remote control repeatedly until ANT/CABLE 1 is selected.



ANT/CABLE 1
ANT/CABLE 2
VIDEO 1
VIDEO 2
S-VIDEO 1
VIDEO 3
S-VIDEO 2

To Select PIP Source

The PIP inset source can be either ANT/CABLE 1 or 2 connections, or any of the VIDEO connections. The following example selects VIDEO 1 for the PIP source, which is the most common setup.

1. Select TV mode of operation for the remote control.
2. Press MENU on the remote until the PIP Menu is selected.

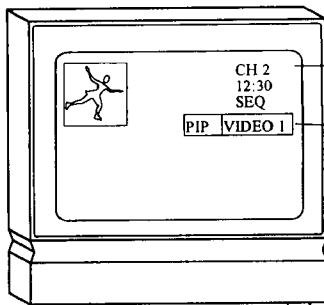

Source of main picture
Source of PIP

3. Use SELECT Up/Down to choose PIP SOURCE then press SOURCE repeatedly to select VIDEO 1.

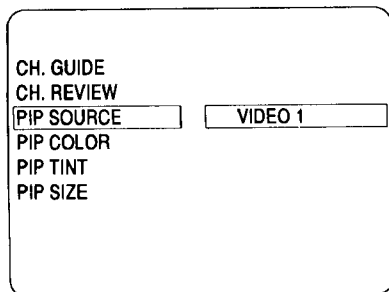

4. Press ENTER to remove menus from the screen.
5. Press PIP on the remote to view the PIP inset.
6. Use the VCR to change the channel in the PIP inset, or to view a tape in the PIP inset.
7. Use ADJUST Left/Right and SELECT Up/Down to position the PIP inset anywhere on the TV screen.

PIP FUNCTIONS

PIP

Press PIP to display the PIP inset. Press PIP again to remove inset.

Moving The Pip Inset Location

Use four-way arrows (ADJ/SELECT) to move PIP inset to the desired location on the TV screen.

Swap

Press SWAP to swap the main picture with the PIP inset. Press SWAP again to return to the original display.

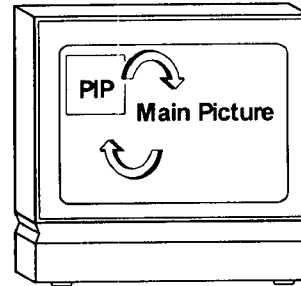

Swap switches the Video from the Main Picture to the PIP inset and the PIP inset to the Main Picture

PIP Size

Select PIP Size in the PIP Menu to choose between seeing a large or small PIP inset.

Freeze

Press FREEZE to freeze motion of the picture shown in the PIP inset. Press FREEZE again to return to a live PIP inset.

When the PIP inset is not currently displayed, pressing FREEZE provides an instant PIP freeze-frame of the program you are watching. Press PIP again to return to normal TV viewing. This function can be used without a second source to retain a phone number or freeze a football play.

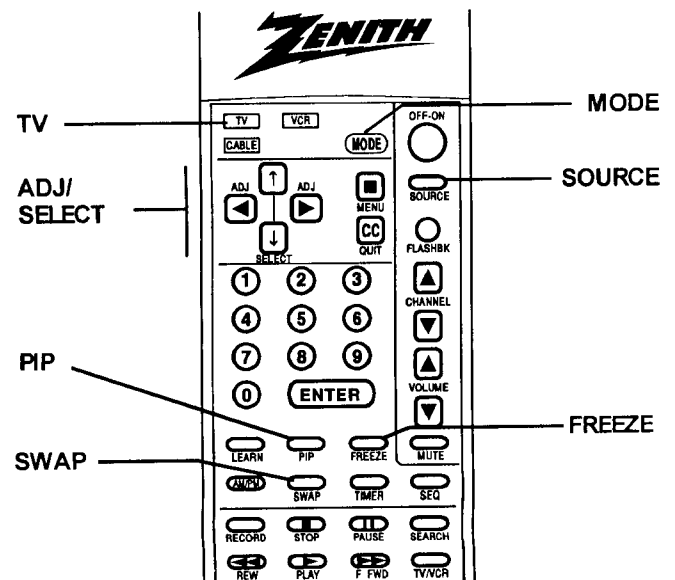

Typical Remote

Your remote may differ from unit shown.

MAINTENANCE AND TROUBLESHOOTING

CARING FOR YOUR PROJECTION TV

Your projection TV will look better, have a longer life and perform better if you care for it properly.



First check to see that the TV is off. For added safety, disconnect AC power to your TV.

NOTE: If you disconnect AC power to your TV for an extended time period, you will have to reset the clock.

Picture Screen Cleaning

Use a soft cloth moistened with warm water and rub lightly in the soiled areas of the screen. **DO NOT USE A TISSUE OR PAPER TOWEL, AS THESE MAY DAMAGE SURFACE.** Wipe only in the vertical (up/down) direction (along the grooves). If there is a dirt buildup, a mild solution of warm water and Ivory dishwashing detergent may be used. Use dry soft cloth to dry the screen. Care should be taken to avoid scratches or damage to the screen surface.

NOTE — The TV screen is easily damaged. Avoid accidental contact with the screen.

EXTENDED ABSENCE

Before an extended absence (such as a vacation) you may want to disconnect AC power to your TV. This will protect the projection TV from possible damage from lightning or power line surges. If you have an outdoor antenna, you may also want to disconnect the antenna from the wall plate connection center

NOTE: If you disconnect AC power to your TV for an extended time period, you will have to reset the clock.

PICTURE INTERFERENCE

Your picture may be affected by interference caused by one or a number of factors. These include:

Nearby Automobile Ignition, Electrical Appliances, etc.

Which causes a speckled, streaked picture. This is most noticeable in weak signal areas.

Snow in Picture Caused by insufficient signal. Usually caused by the TV being located too far from the TV station or by an improper antenna installation.

Ghosts or Reflections Caused by signals being reflected from surrounding buildings, water tanks, or other high structures.

Radio Signal Police, amateur or CB radio transmitters may cause interference.

These interference problems can often be corrected through the use of a better antenna, signal amplifiers, or various filter devices. See your TV dealer for additional information, and accessories available for your projection TV.

MAINTENANCE AND TROUBLESHOOTING

BEFORE CALLING FOR SERVICE

Check these items and see if you can correct the trouble by changing the adjustment of a control or the setting of a switch.

By making these simple checks before calling for service, you may save time and money.

Problem	Try This
Picture OK. Poor sound.	Re-orient antenna. Try another channel — possible station trouble. Check for local interference. Check AUTO TUNING and TUNING BAND options.
Sound OK. Poor picture.	Re-orient antenna. Try another channel — possible station trouble. Adjust VIDEO Menu options with PICTURE PREF. in CUSTOM mode.
No picture or sound.	Is TV on? Is there power in wall outlet? Is TV plugged in? Is antenna hooked up? Is cable hooked up? Is cable operational? Check auxiliary audio/video equipment. Check channel selection. Check TUNING BAND and AUTO TUNING Menu options.
Picture blurred, ghost in picture, or distorted.	Check antenna or cable hook up for broken wires or loose connection. Try another channel — possible station trouble. Check for local interference.
No color, or poor color.	Try another channel — possible black and white program. Check antenna or cable hook up for broken wires or loose connection. Adjust VIDEO Menu options with PICTURE PREF. in the CUSTOM mode. Is it a color program?
No sound.	VOLUME (VOL) setting may be too low. Check MUTE button operation on remote control, if provided. Is Speaker EXT/INT switch in EXT position?
Cannot select certain channels.	Channels may be skipped in CH. ADD/DEL Menu option. Check TUNING BAND and AUTO TUNING options.
Remote control does not work.	Are batteries okay? Is TV turned ON? Is TV plugged in?
No closed captions.	Are captions available? Is CAPTION 1 or 2 selected by using the CAPTIONS option on the SETUP Menu.
Black or blue box covers 1/2 of screen.	Is text information available? Is TEXT 1 or 2 selected by using the CAPTIONS option on the SETUP Menu?
No picture or sound when VCR source is selected.	Is VCR hooked up properly? Are wires connected to VCR-VIDEO 1/2 jacks on connection center?
No sound or weak stereo sound when using a stereo VCR.	Check AUDIO mode? Is it STEREO? Was stereo present before selecting VIDEO 1/2 or S-VIDEO Source?
PIP is black when using VCR for PIP source.	Is VCR hooked up properly? Are wires connected to the VIDEO 1/2 input jacks on connection center? Is VCR selected for PIP source?
PIP lacks contrast when using VCR for PIP source.	Is VCR hooked up properly? Are wires connected to the VIDEO 1/2 input jacks on connection center?
PIP inset frame is snowy when using TV tuner for PIP and VCR for main picture.	Is TV/VCR switch on VCR in the TV position?

Always request that your technician use only genuine Zenith exact replacement parts for continued quality and safety performance. Keep your Zenith **ALL** Zenith.

NOTE: If your TV fails to respond to any other menu selection, you must reset the TV. Simply disconnect the AC power. Wait a few minutes, then reconnect the AC power.

YOUR ZENITH WARRANTY

Consumer Protection Plan for Zenith Projection TV

Welcome into the Zenith family! We believe that you will be pleased with your new Zenith Projection TV. Please read this Consumer Protection Plan carefully. It is a "ONE YEAR FULL WARRANTY," plus a limited second year picture tube warranty, as defined under federal law. This warranty gives you specific legal rights, and you may also have other rights that vary from state to state within the U.S.A.

Zenith's Responsibility

Service Labor and Parts — During a period of one year from effective warranty date, Zenith will supply new or re-manufactured replacement picture tubes or other parts, and will pay for service labor by a Zenith distributor or distributor-approved Zenith service center, when such parts or service labor are needed to repair the product as a result of manufacturing defects. Further, Zenith will supply a new or re-manufactured replacement for any picture tube which fails during the second year after effective warranty date because of a manufacturing defect. Replacement parts are warranted for the remaining portion of the original warranty period. The above service labor warranty applies only in the U.S.A.

On-Site Service — Warranty service is provided when the Projection TV is installed.

Not Covered — This warranty covers manufacturing defects and does not cover installation, adjustment of customer controls in the home, installation or repair of home antenna systems, cable converters or cable company-supplied equipment; it also does not cover damage due to misuse, abuse, negligence, acts of God or other causes beyond the control of Zenith. Any alteration of the product after manufacture voids this warranty in its entirety.

Owner's Responsibility

Effective Warranty Date — Warranty begins on the date of original consumer installation. For your convenience, keep the dealers dated bill of sale or delivery ticket as evidence of the purchase date.

Operating Guide — Read your Operating Guide carefully so that you will understand the operation of your set and how to adjust the customer controls.

Antenna — Reception problems caused by inadequate home antennas or faulty antenna connections are the owner's responsibility.

Important: Product Registration — Please fill out and mail your Owner Registration Card. It is imperative that Zenith know how to reach you promptly if we should discover a safety problem that could affect you.

Warranty Service — For warranty service information, contact your Zenith dealer preferably, or any distributor-approved Zenith service center. Parts and service labor that are Zenith's responsibility (see above) will be provided without charge. Other service is at the owner's expense. If you have any problem in obtaining satisfactory warranty service, write:

Zenith Electronics Corporation

Customer Service Department

1900 N. Austin Avenue

Chicago, Illinois 60639-5079

Telephone: (312) 745-5152

Mon-Fri, 8:00 a.m. - 4:30 p.m. Central Time

NOTE: Before you ask for Warranty service, check the Operating Guide section entitled, "MAINTENANCE AND TROUBLESHOOTING." It may be possible to avoid a service call.

ZENTH ELECTRONICS CORPORATION
1000 MILWAUKEE AVENUE
GLENVIEW, ILLINOIS 60025

Part No. 206-2738
Printed in U.S.A.
EP-EDCBAO
