



 Advanced Video Imaging

**Direct View Color TV
MTS Stereo Audio
Picture-In-Picture
Surround Sound**

*Return the Product
Registration Card,
and your TV
could be
FREE!*

**OPERATING GUIDE & WARRANTY
for models ...**

SR2745, SR2786, SR2789,
SR3247, SR3289, SR3547
SR3589

ZENITH ELECTRONICS CORPORATION
1000 MILWAUKEE AVENUE
GLENVIEW, ILLINOIS 60025

Part No. 206-2918-01
Printed in U.S.A.
EP-EDCBA

WATCH US.



WARNING

RISK OF ELECTRIC SHOCK
DO NOT OPEN



WARNING: TO REDUCE THE RISK OF ELECTRIC SHOCK DO NOT REMOVE COVER (OR BACK). NO USER SERVICEABLE PARTS INSIDE. REFER TO QUALIFIED SERVICE PERSONNEL.

TO PREVENT FIRE OR SHOCK HAZARDS, DO NOT EXPOSE THIS PRODUCT TO RAIN OR MOISTURE.



The lightning flash with arrowhead symbol, within an equilateral triangle, is intended to alert the user to the presence of uninsulated "dangerous voltage" within the product's enclosure that may be of sufficient magnitude to constitute a risk of electric shock to persons.



The exclamation point within an equilateral triangle is intended to alert the user to the presence of important operating and maintenance (servicing) instructions in the literature accompanying the appliance.

Safety Tips

Refer to the "Safety Tips" booklet that came with your product for important safety considerations.

Note to Cable TV System Installer

This reminder is provided to call the cable TV system installer's attention to Article 820-40 of the NEC that provides guidelines for proper grounding and, in particular, specifies that the cable ground shall be connected to the grounding system of the building, as close to the point of the cable entry as practical.

Power-Cord Polarization

This product is equipped with a polarized alternating-current line plug (a plug having one blade wider than the other.) This plug will fit into the power outlet only one way. This is a safety feature. If you are unable to insert the plug fully into the outlet, try reversing the plug. If the plug should still fail to fit, contact your electrician to replace your obsolete outlet. Do not defeat the safety purpose of the polarized plug.

CAUTION

To prevent electric shock, match wide blade of plug to wide slot, fully insert.

ATTENTION

Pour éviter les chocs électriques, introduire la lame la plus large de la fiche dans la borne correspondante de la prise et pousser jusqu'au fond.

CONTENTS

Part 1. Connections and Basic Operations

INTRODUCTION	
Welcome	ii
Installation Considerations	ii
Methods of Operation	iii
Model/Features Chart	iii

STANDARD CONNECTIONS FOR YOUR TV

Connection Center, Cable, VCR, S-Video, Accessory Jacks, Speakers, Audio Amplifier, and Connections For Using PIP	1-1
-------------------------------------------------------------------------------------------------------------------------	-----

FIRST TIME YOU OPERATE YOUR TV

Control Panel, Battery Installation, Power, Source, Auto Program, Clock, and Other Options	2-1
--------------------------------------------------------------------------------------------------	-----

PIP OPERATION

Introduction, Selecting Main Picture and PIP Inset Source, PIP Functions, Operation With Various Configurations	3-1
-----------------------------------------------------------------------------------------------------------------------	-----

Part 2. Universal Remote Control and Menus

UNIVERSAL REMOTE CONTROL

Battery Installation, Operating Mode, TV Operations, StarSight Operations, Operational Modes, Programming, Special Features, Auto Find, and Brand Codes	3-1
---------------------------------------------------------------------------------------------------------------------------------------------------------------	-----

QUICK REFERENCE TO MENUS

Available Menus, and Basic Operation	4-1
--------------------------------------------	-----

SOURCE MENU

Menu Operation, Source Selection, and Source Identification	5-1
-------------------------------------------------------------------	-----

SETUP MENU

Auto Program, Ch. Add/Del, Ch. Labels, Source ID, Clock Set, Timer Setup, Parental Ctl, Caption/Text, Background, and StarSight	6-1
---------------------------------------------------------------------------------------------------------------------------------------	-----

AUDIO MENU

Bass, Treble, Balance, Audio, SEQ, Surround and Null	7-1
------------------------------------------------------------	-----

VIDEO MENU

Contrast, Brightness, Color, Tint, Sharpness, Color Temp, Video Filter, Auto Flesh, and Picture Pref	8-1
------------------------------------------------------------------------------------------------------------	-----

PIP MENU

Ch. Guide, Ch. Review, PIP Color, PIP Tint, and PIP Size	9-1
----------------------------------------------------------------	-----

Part 3. Z-Trak Remote Control and Menus

Z-TRAK REMOTE CONTROL

Battery Installation, Operating Mode, Basic Operations and Auto Find	11-1
----------------------------------------------------------------------------	------

QUICK REFERENCE TO MENUS

Available Menus, Accessing the Menu, Channel Icons and Volume Control	12-1
-----------------------------------------------------------------------------	------

TV OPTIONS MENU

Timer, Captions, Z-Trak, PIP, Freeze and Move PIP	13-1
---------------------------------------------------------	------

SOURCE MENU

Menu Operation, Source Selection, and Source Identification	14-1
-------------------------------------------------------------------	------

SETUP MENU

Auto Program, Ch. Add/Del, Ch. Labels, Source ID, Clock Set, Timer Setup, Parental Ctl, Caption/Text, Background, and StarSight	15-1
---------------------------------------------------------------------------------------------------------------------------------------	------

AUDIO MENU

Bass, Treble, Balance, Audio, SEQ, Surround, and Null	16-1
-------------------------------------------------------------	------

VIDEO MENU

Contrast, Brightness, Color, Tint, Sharpness, Color Temp, Video Filter, Auto Flesh, and Picture Pref	17-1
------------------------------------------------------------------------------------------------------------	------

PIP MENU

Ch. Guide, Ch. Review, PIP Color, PIP Tint, and PIP Size	18-1
----------------------------------------------------------------	------

Part 4. Maintenance, Accessories, and Warranty

MAINTENANCE AND TROUBLESHOOTING

Caring, Extended Absence, Interference, Before Calling for Service	19-1
--------------------------------------------------------------------------	------

Replacement Product Registration Card

Accessories for Your TV

Your Zenith Warranty

How to use this operating guide

Standard TV installation and operation is given in this portion of the operating guide. Follow the procedures given if you will not be using StarSight®.



Refer to the StarSight® portion of this operating guide for StarSight® installation and operation.

INTRODUCTION

WELCOME

Welcome into the family of Zenith Color Television owners. This guide provides instructions on how to operate your new TV. It is supplemented by a booklet containing Safety Tips. We urge you to read these publications carefully so that you will receive full enjoyment from your new Zenith TV for many years to come.

Your new TV has been designed and built to give you the very best in quality, features and performance. There are thousands of Zenith authorized service centers throughout the U.S., Canada and Mexico who can attend promptly and effectively to ordinary service needs.

If you should have an unusual performance or service problem that cannot be satisfactorily resolved by your Zenith dealer or Zenith authorized service center, contact us at:

Zenith Electronics Corporation
Customer Service Department
1000 Milwaukee Avenue
Glenview, IL 60025
Telephone: (708) 391-8752
Mon-Fri, 8:00 a.m. - 4:30 p.m. Central Time

Send the model number, serial number, and date of purchase or original installation, with a full explanation of the problem and the service history. We will welcome the opportunity to look into your specific question or problem and to be of assistance in resolving it promptly.

The model and serial numbers of your new TV are located on the back of the TV cabinet. For your future convenience and protection, we suggest that you record these numbers here:

Model No. _____

Serial No. _____



Manufactured under license from Dolby Laboratories Licensing Corporation. "Dolby" and the double-D symbol are trademarks of Dolby Laboratories Licensing Corporation.

INSTALLATION CONSIDERATIONS

Before you install your TV...



Ventilation — Proper ventilation keeps your TV running cool. Air circulates through perforations in the back and bottom of the cabinet. Do not block these vents or you will shorten the life of your TV.



Power Source — Your TV is designed to operate on normal household current, 120 volt 60 Hertz AC. Do not attempt to operate it on DC current.



Power Cord — Your power cord has a polarized plug as required by Underwriters' Laboratories. It has one regular blade and one wide blade and fits only one way into a standard electrical outlet. If the blades will not enter either way, your outlet is very old and non-standard. A new outlet should be installed by a qualified electrician.



Safe Operation — Your TV is manufactured and tested with your safety in mind. However, unusual stress caused by dropping or mishandling, exposure to flood, fire, rain or moisture, or accidental spilling of liquids into the TV, can result in potential electrical shock or fire hazards. If this happens, have your TV checked by a service technician before using it again.

Please read and observe each safety point in the "Safety Tips" folder when installing and using your TV.

VIDEO GAMES AND OTHER FIXED

PATTERN DISPLAY CAUTION — If you use your TV for video games, teletext or other fixed displays, avoid setting the BRIGHTNESS control for an excessively bright picture. A bright, fixed pattern, if used for long periods of time, can result in a permanent imprint on the TV picture tube. You can reduce this possibility by alternating the use of the fixed pattern display with normal TV picture viewing, by turning down the CONTRAST control for sustained fixed pattern use, and by turning off the fixed pattern display when not in use.

PLUGGING IN YOUR TV — Be sure to plug your TV into an "unswitched" AC power source. The "switched" AC outlets found on some video equipment will not continue supplying power to the TV once the equipment is turned off. If the power to the TV is interrupted, you will have to reset the clock in the TV to the current time.

INTRODUCTION

METHODS OF OPERATION

Your TV is a very sophisticated appliance. Optional features, video picture adjustments and audio sound adjustments are performed through on-screen menus and displays. Self explanatory ICONS are used throughout. Most features can be selected and adjusted from the comfort of your favorite chair by using either of the infrared remote controls.

Either of two remote controls can be used to operate the TV. Use the multi-brand programmable remote if you have different brands and types of equipment in your video system which you need to control remotely. Use the Z-Trak programmable remote if you feel comfortable using track-ball access similar to that provided by the familiar computer mouse device. Many features can be selected and adjusted by using the control panel provided on the TV.

StarSight provides an electronic programming guide which is updated with new scheduling information automatically on a periodic basis. StarSight allows you to rapidly scan through the programming guide to find a program for viewing or recording. Programs can be searched and selected by category if desired.

Method of Operation	Standard TV	StarSight
• Control Panel on TV.	YES	NO
• Universal Remote Control	YES	YES
• Z-Trak Remote Control	YES	YES

FEATURES PROVIDED WITH YOUR TV

This operating guide describes a family of TV models. Not all models have all of the features described in this guide. Different control panels may be used from model to model. Most models include the following features:

FEATURE	MODEL	SR2745, SR3247	SR2786, SR2789, SR3289, SR3589	SR3547
• StarSight Electronic Program Guide		Y	Y	Y
• StarSight Demonstration		Y	Y	Y
• On-Screen Menus Accessed By Remote or TV Controls		Y	Y	Y
• Universal Programmable Remote Control		Y	Y	Y
• Z-Trak Programmable Remote Control		Y	Y	Y
• Picture-In-Picture		Y	Y	Y
• 181 Channel Tuning (STD/ HRC/ ICC Band Selected Automatically)		Y	Y	Y
• Automatic Channel Programming		Y	Y	Y
• Favorite Channel Add/Delete		Y	Y	Y
• Channel Labels (ABC, TNT, etc.) for Easy Channel Identification		Y	Y	Y
• Multiple Input Sources		Y	Y	Y
• Source Identification (VCR, Cable, etc.)		Y	Y	Y
• Antenna/Cable and Loop Out Jacks		Y	Y	Y
• Audio/Video (A/V) Jacks		Y	Y	Y
• Super-VHS A/V Input Jacks		Y	Y	Y
• Front Mounted A/V Jacks		N	N	Y
• Surround Sound System		Premium	Standard	Dolby
• MTS Stereo with SEQ (Spatial Equalization)		Y	Y	Y
• Surround Sound Speaker Terminals		Y	Y	Y
• Variable Audio Output Jacks		Y	Y	Y
• Surround Sound Speakers		Optional	Optional	Optional
• Sleep Timer and On/Off Timer		Y	Y	Y
• Closed Caption and Text Modes		Y	Y	Y
• Parental Control		Y	Y	Y

STANDARD CONNECTIONS FOR YOUR TV

CONNECTION CENTER

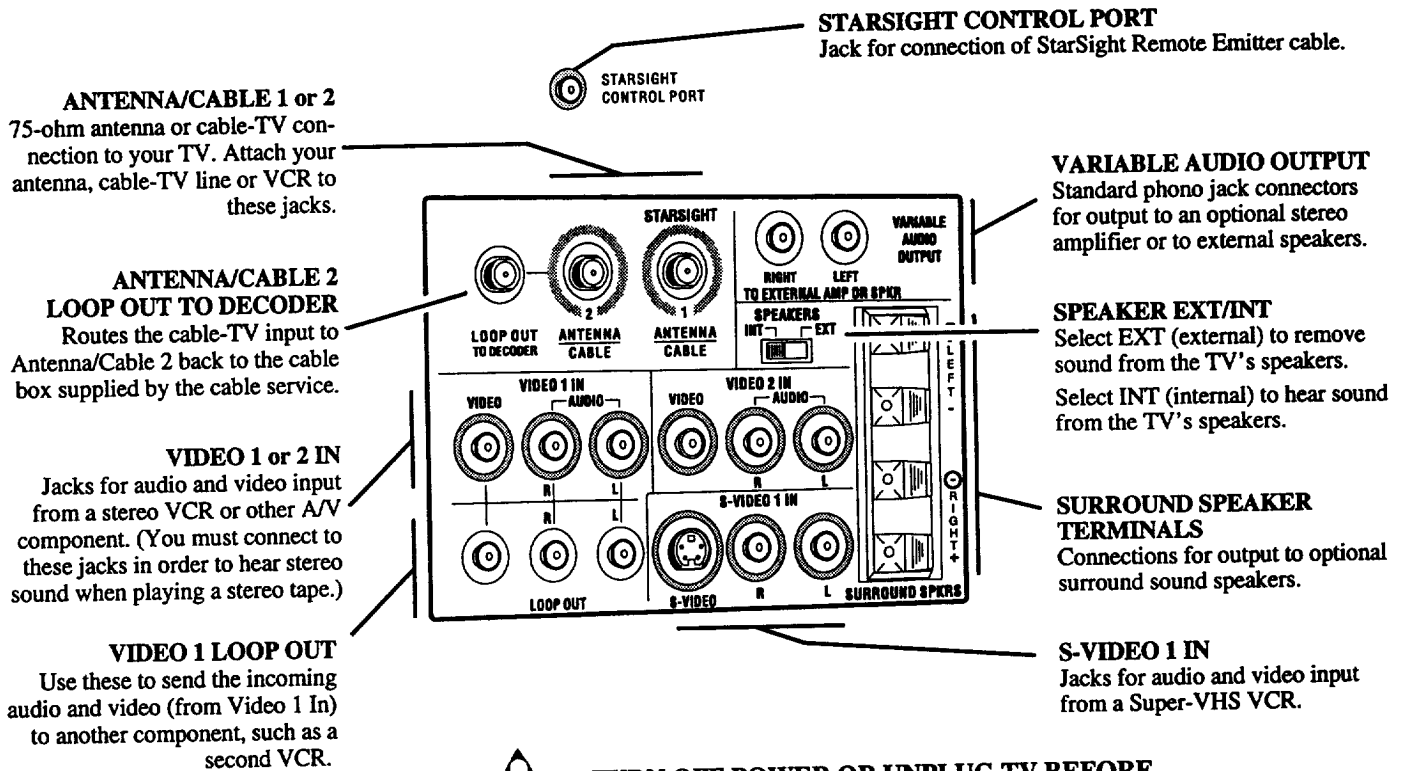

TURN OFF POWER OR UNPLUG TV BEFORE MAKING ANY CONNECTION.

OTHER JACKS ON TV (Some Models)

S-VIDEO 2 IN
Jacks for audio and video input from a second Super-VHS VCR.

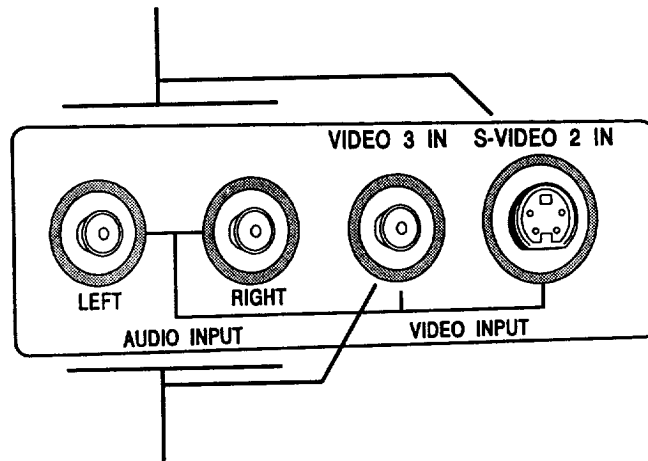

VIDEO 3 IN
Jacks for audio and video input from a third stereo VCR or other A/V component.

STANDARD CONNECTIONS FOR YOUR TV

BASIC CONNECTION TO TV WITHOUT VCR

If a VCR will not be connected to your TV, you have three basic connection options, as shown.

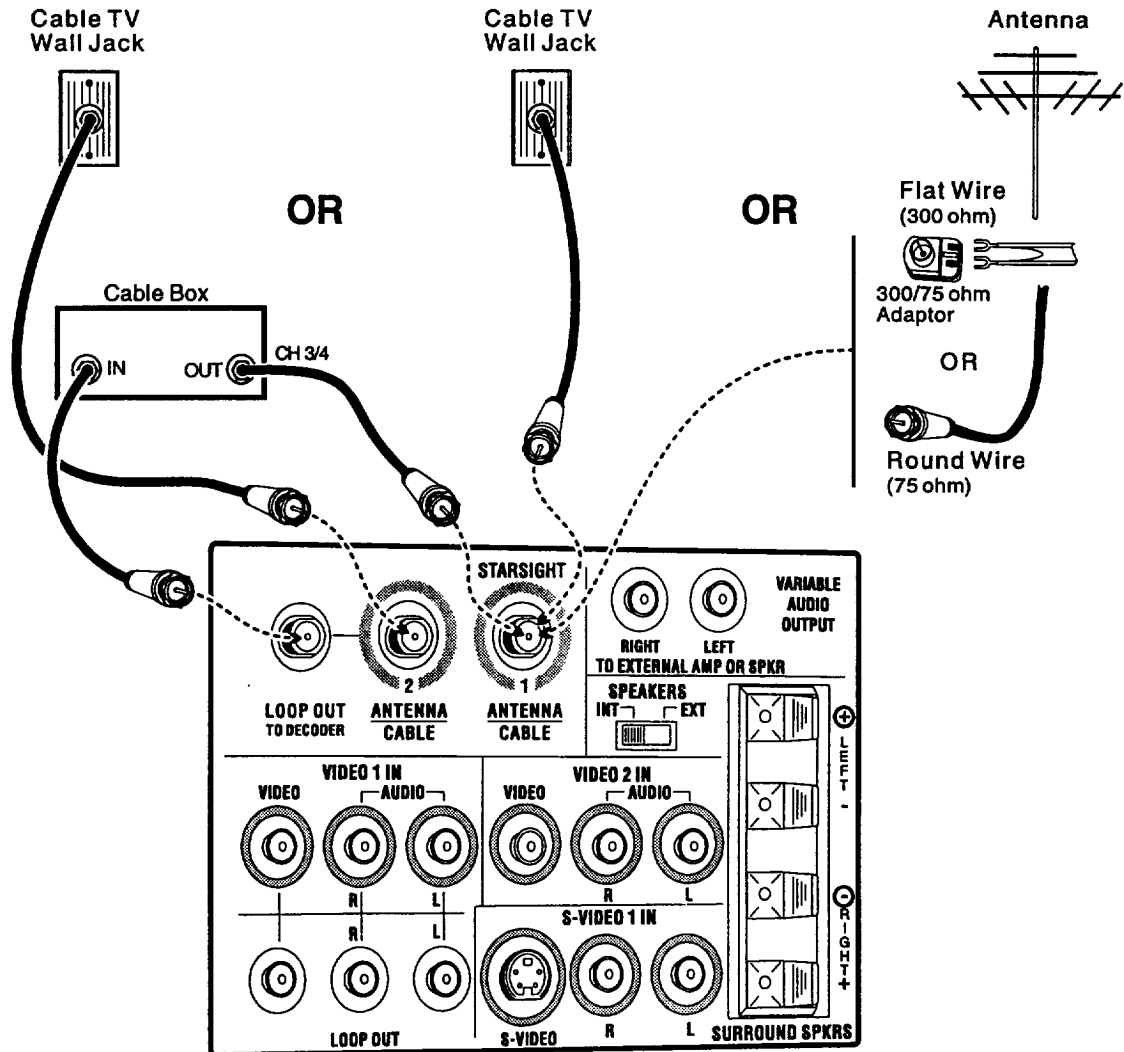

OPERATING YOUR TV	
With Cable Box	Without Cable Box
<ul style="list-style-type: none"> • Select Ant/Cable 1 in Source Menu. • Tune TV to cable box output channel (usually channel 3 or 4). • Use cable box to select channels for viewing. 	<ul style="list-style-type: none"> • Select Ant/Cable 1 in Source Menu. • Use TV to select channels for viewing.

STANDARD CONNECTIONS FOR YOUR TV

BASIC CONNECTION TO TV WITH VCR

If you are connecting a VCR to your TV, you have three basic connection options, as shown.

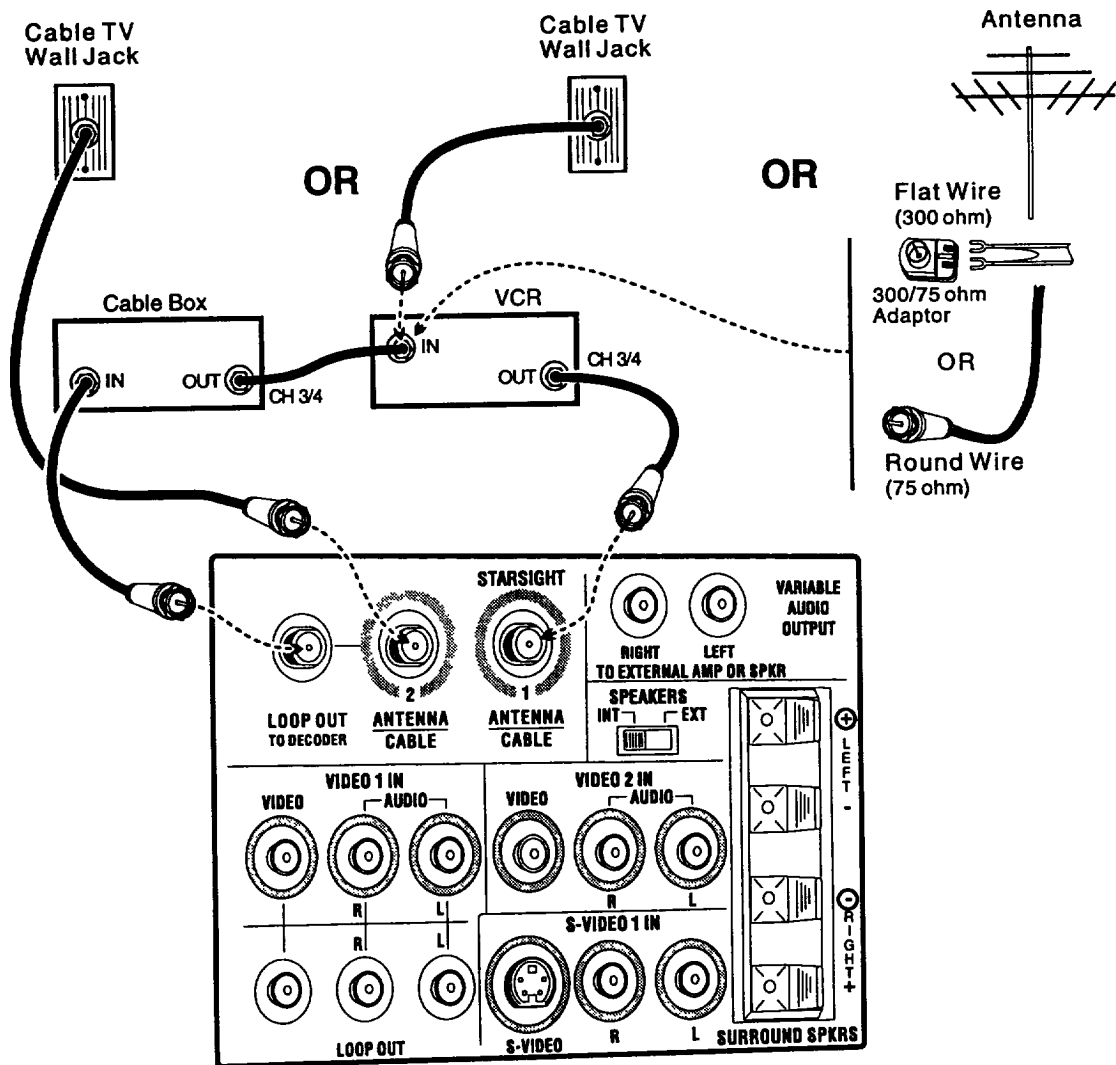

OPERATING YOUR TV

VCR's TV/VCR* Switch Setting	With Cable Box	Without Cable Box
TV	<ul style="list-style-type: none"> Select Antenna/Cable 1 in Source Menu. Tune TV to cable box output channel (usually channel 3 or 4). Use the cable box to select channels for viewing. 	<ul style="list-style-type: none"> Select Antenna/Cable 1 in Source Menu. Use TV to select channels for viewing.
VCR	<ul style="list-style-type: none"> Select Antenna/Cable 1 in Source Menu. Tune VCR to cable box output channel (usually channel 3 or 4). Tune TV to VCR output channel (usually channel 3 or 4). Use the cable box to select channels for viewing. 	<ul style="list-style-type: none"> Select Antenna/Cable 1 in Source Menu. Tune TV to VCR output channel (usually channel 3 or 4). Use VCR to select channels for viewing.

* May be labeled TV/Video.

STANDARD CONNECTIONS FOR YOUR TV

ADDITIONAL CONNECTIONS FOR STEREO VCR

If you have a stereo VCR, or other stereo audio/video (A/V) component, you must make these additional connections shown below in order to hear stereo sound from the component.

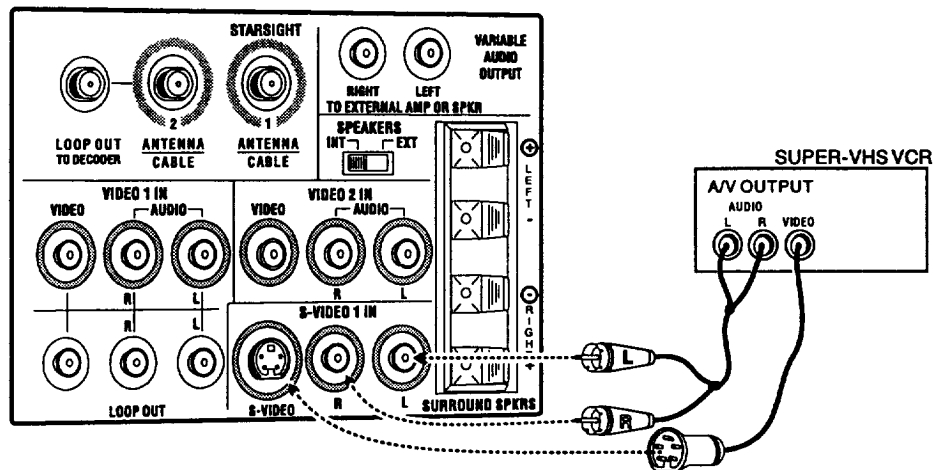
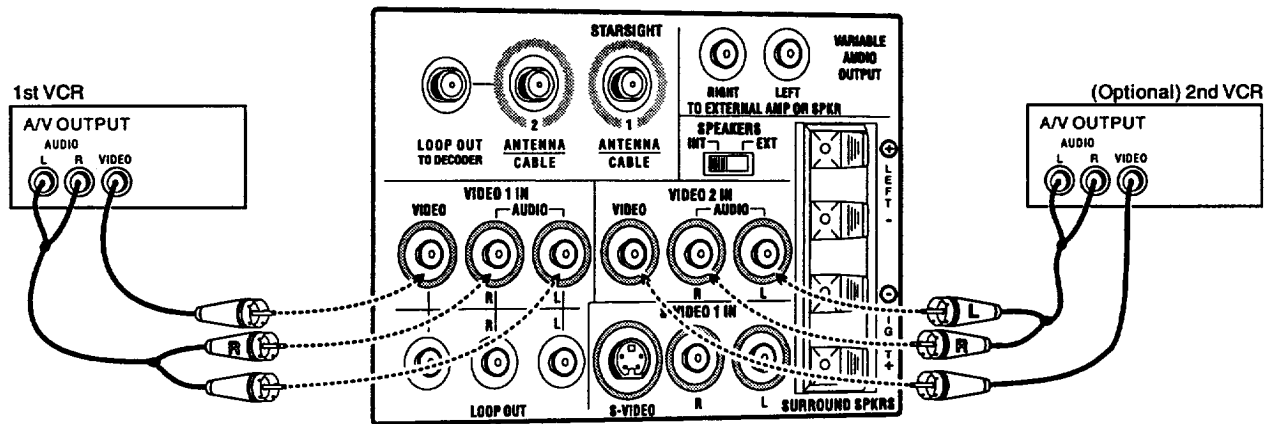

OPERATING YOUR TV USING A/V JACKS

- Select Video 1* from the Source Menu.
- Use VCR (or other component) to select channels for viewing. or,
- Watch a tape playing in the VCR.

* Select the Source in the **Source Menu** that corresponds to jacks to which the A/V component is connected.

STANDARD CONNECTIONS FOR YOUR TV

AUDIO/VIDEO (A/V) CONNECTIONS FOR OPTIONAL VIDEO EQUIPMENT

Connections to VIDEO 3 IN or S-VIDEO 2 IN jacks. (Some TV models only.)

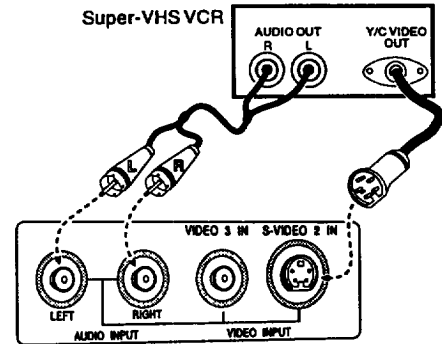
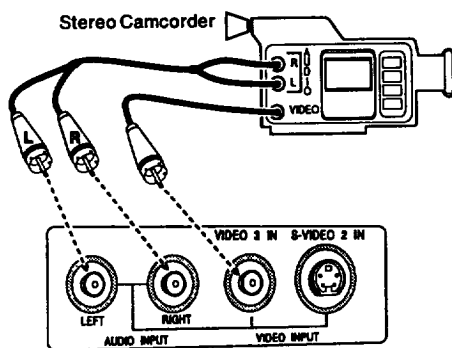

OPTIONAL AUDIO AMPLIFIER/SURROUND SOUND CONNECTIONS TO TV

If you wish to listen to the TV audio through an external amplifier or stereo system, or listen to surround sound audio, make the connections to the TV shown in the illustration below.



TURN OFF POWER OR UNPLUG TV BEFORE MAKING ANY CONNECTION.

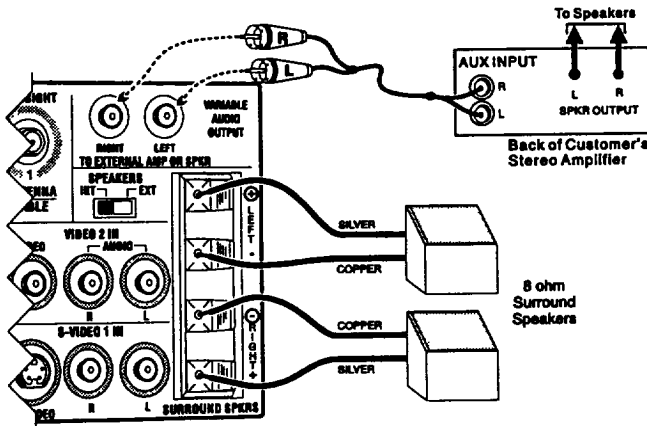

Amplifier and Dual Surround Speaker Connections

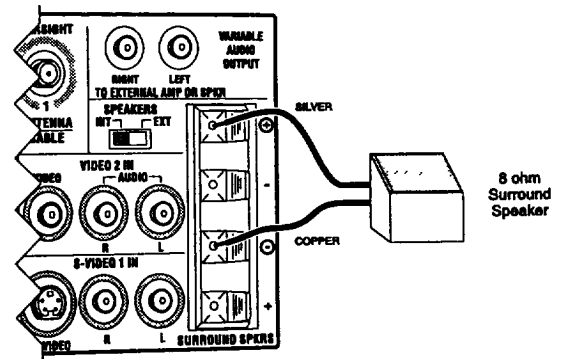

Single Surround Speaker Connection

DIFFERENT WAYS TO LISTEN TO YOUR TV

TV Speakers On	TV Speakers Off	Surround Sound
<ul style="list-style-type: none"> • SPEAKER EXT/INT switch in the INT (internal) position — TV speakers are ON. Sound is heard from both the TV's speakers and the external amplifier's speakers. • Use TV's volume control to raise and lower the level of sound being heard from both sets of speakers. 	<ul style="list-style-type: none"> • SPEAKER EXT/INT switch in the EXT (external) position — TV speakers are OFF. Sound is only heard from the speakers connected to the external amplifier. • Use TV's volume control to raise and lower the level of sound being heard from the amplifier's speakers. 	<ul style="list-style-type: none"> • Connect surround sound speakers as shown. The level of surround sound will vary, depending on the program being viewed. Note that not all programs have surround sound audio. • The SURROUND SPKR terminals are always active. The SPEAKERS EXT/INT switch does not affect the operation of surround sound speakers. • If you want to connect only one surround speaker to your TV, connect the speaker wires to the terminals adjacent to the positive (+) and negative (-) symbols that are circled.

STANDARD CONNECTIONS FOR YOUR TV

CONNECTIONS FOR USING PIP

The illustrations that follow show the most common connections for using Picture-In-Picture (PIP). For further information on the actual use of PIP, refer to the "PIP OPERATION" section of this operating guide.

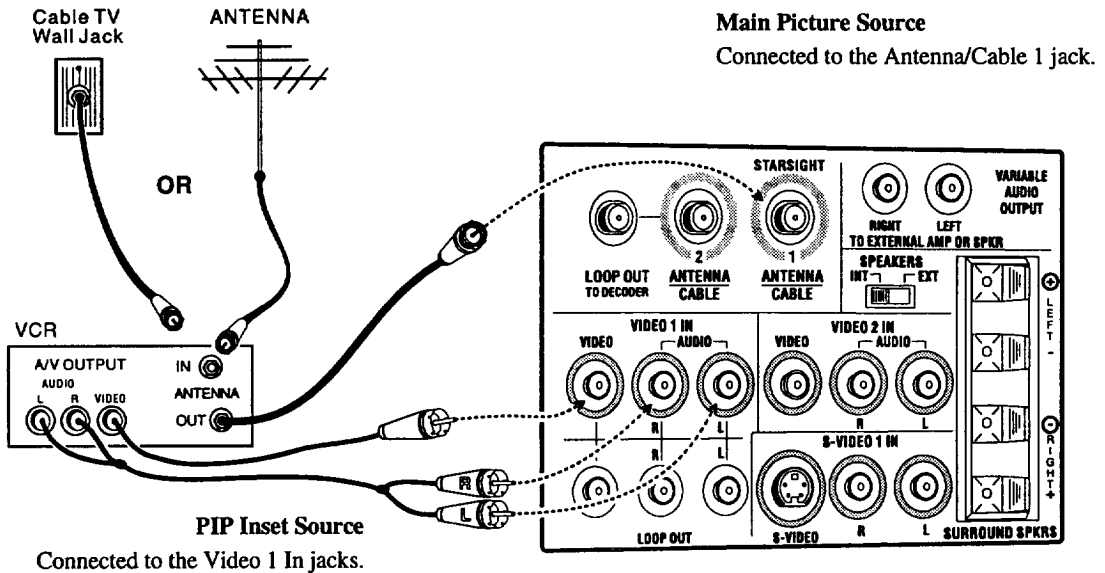

Option 1: Antenna or Direct Cable Connection To VCR.
(Cables are not supplied with television.)

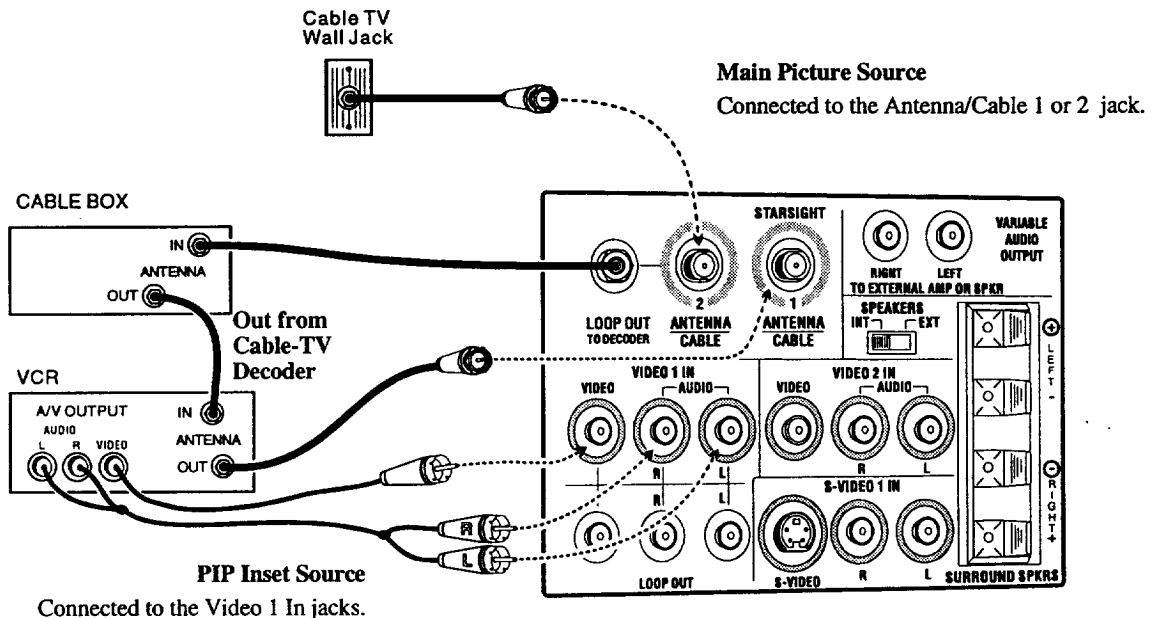

Option 2: Cable-TV Decoder Connection via Loop Out To VCR.
(Cables are not supplied with television.)

THE FIRST TIME YOU OPERATE YOUR TV

TYPICAL CONTROL PANEL

The control panel on your TV may differ from the one shown but its operation is the same.

ENTER (ENT)

Press to see the Channel/Time display, or to remove any on-screen display or menu.

SELECT (SEL)

Press during on-screen menu operations to select a menu option.

VOLUME (VOL) Up/Down

Press to increase or decrease the sound level.

OFF-ON

Press to turn TV power ON or OFF.

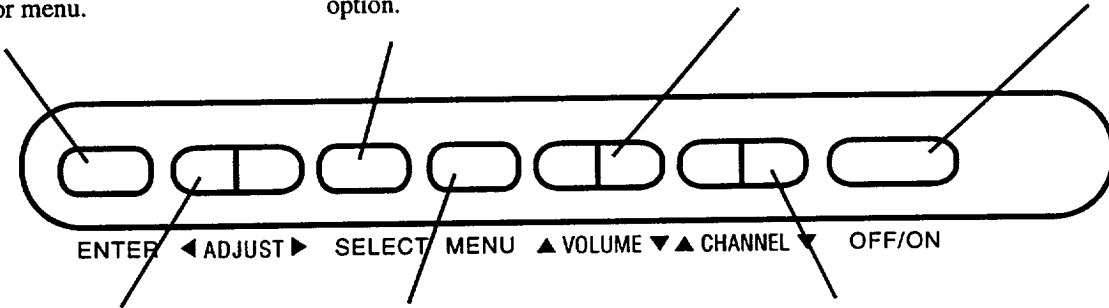

ADJUST (ADJ) Left/Right

Press during on-screen menu operation to see information/status display for selected option. Press again to adjust the selected menu option.

MENU

Press once to see a menu. Press repeatedly to sequence through the available menus.

CHANNEL (CH) Up/Down

Press to select channels higher or lower than the current channel. To add or delete channels stored in the scanning sequence, see CH. ADD/DEL option.

Remote Window
Point the remote control towards this window to operate the TV.

STEP 1. INSTALL THE BATTERIES INTO THE REMOTE CONTROL

Batteries are provided but they must be installed before using the remote controls. When a remote no longer functions normally, or when it loses memory, replace the batteries with two high-quality, alkaline batteries. Match plus with plus (+ with +), minus with minus (- with -), as shown in the battery compartment.

Unless your equipment responds to the factory preset codes, you will need to reprogram the remote controls with the codes of your particular equipment each time you replace batteries.

NOTES:

- Do not place heavy objects on top of the remote control keys. Prolonged unintentional operation of the remote shortens battery life.
- Remove the batteries if the remote control will not be used for a month or more. **THE MANUFACTURER IS NOT RESPONSIBLE FOR DAMAGE CAUSED BY BATTERY LEAKAGE.**

Universal Remote

(Uses 2 size AAA batteries.)

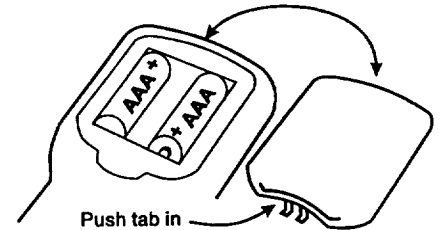

Z-Trak Remote

(Uses 2 size AA batteries.)

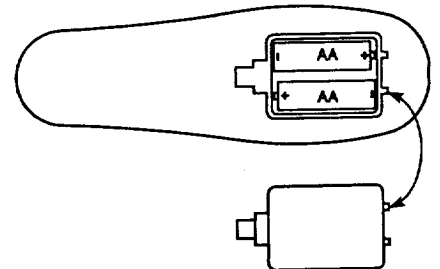

STEP 2. CONNECT THE POWER

1. Plug your TV into an unswitched AC power source.
2. Turn the TV on by pressing OFF-ON.

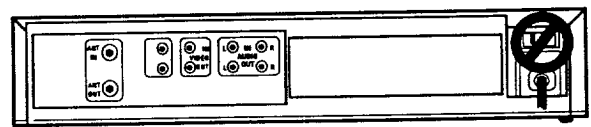

Do not plug TV into switched outlet on a VCR or cable-TV decoder

THE FIRST TIME YOU OPERATE YOUR TV

STEP 3. SELECT YOUR MAIN SOURCE & PIP SOURCE

A TV source refers to the equipment connected to the TV that supplies the picture and sound to your TV. You select the viewing source by using the Source Menu.

Main Source	PIP Source
<ul style="list-style-type: none"> Press SOURCE on your remote to view the Source Menu. Press SOURCE repeatedly to select the source which corresponds to the jack on the TV connection panel that is receiving the input signal. Press QUIT to remove the menu. 	<ul style="list-style-type: none"> Press SOURCE on your remote to view the Source Menu. Press the Left or Right key to select PIP Source column. Press SOURCE repeatedly to select the source which corresponds to the jack that is receiving the PIP input signal. Press QUIT to remove the menu.

Main Source	PIP Source
Ant/Cable 1	Ant/Cable 1
Ant/Cable 2	Video 1
Video 1	Video 2
Video 2	S-Video 1
S-Video 1	Video 3
Video 3	S-Video 2
S-Video 2	

◀▶ Main/PIP ↑↓ To Select Source

Source Menu with Main Source set to Ant/Cable 1 and PIP Source set to Video 1. Connections must be made to the corresponding jacks on the connection panel.

STEP 4. USE AUTO PROGRAM

Auto Program finds all available channels on the currently selected source and stores them in the memory of the TV.

To start the Auto Program procedure, press the Left or Right arrow key. Follow the instructions on the TV.

Auto Program
Ch. Add/Del
Ch. Labels
Source ID
Clock Set
Timer Setup
Parental Ctl
Caption/Text
Background
StarSight

Press ◀▶ To Program

Setup Menu with Auto Program Highlighted

- 1 Press ↑↓ to select either OFF AIR ANTENNA or CABLE TV.
- 2 Press ← → to begin channel search.
- 3 Wait a few seconds for the TV screen to clear.

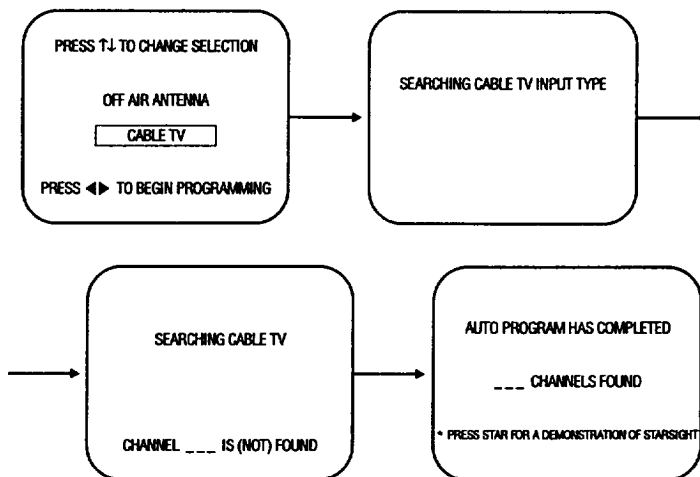

* Message appears only if TV has not been authorized for StarSight.

STEP 5. SET THE CLOCK

Set The Clock
<ul style="list-style-type: none"> Press MENU on your remote until the SETUP icon is selected and the Setup Menu is displayed. Press the Up or Down arrow key to select Clock Set. Use the numbered buttons on the universal remote control to enter the correct time. Press TIMER to select AM or PM. or Press the Left or Right arrow keys to advance the clock. Press QUIT to remove the menu.

STEP 6. USE OTHER OPTIONS

You may want to consider using the following options:

- Delete undesirable channels or add additional channels: Refer to the **Ch. (Channel) Add/Del** option for details.
- Apply "labels" to your available channels: Refer to the **Ch. (Channel) Labels** option for details.
- Label the input sources with descriptive names, such as "VCR." Refer to the **Source ID** option for details.
- Adjust options in the **Audio** and **Video Menus**.

PIP OPERATION

INTRODUCTION

Your TV must be connected to two separate sources in order to view a different picture in the PIP inset from that which is showing in the main picture area of the TV. One source (such as an antenna) must be connected to the ANT/ CABLE 1 or 2 jack. The other source (such as a VCR) must be connected to one set of the Video or Super Video jacks.

If you have not already selected the input sources for your main TV picture and the PIP inset, refer to the instructions below. Make sure you select those sources that correspond to the jacks on the TV connection panel that are receiving the input signals.

Main Source	PIP Source
Ant/Cable 1	Ant/Cable 1
Ant/Cable 2	
Video 1	Video 1
Video 2	Video 2
S-Video 1	S-Video 1
Video 3	Video 3
S-Video 2	S-Video 2

◀▶ Main/PIP ↑↓ To Select Source

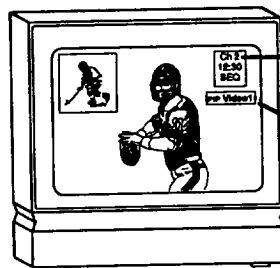

Source of main picture shows here

Source of PIP picture shows here

SELECTING MAIN PICTURE AND PIP INSET SOURCES

SELECT MAIN SOURCE		SELECT PIP SOURCE *	
Universal Remote	Z-Trak Remote	Universal Remote	Z-Trak Remote
<ul style="list-style-type: none"> • Make sure remote is in TV mode. • Press SOURCE on your remote to view the Source Menu. • Press SOURCE repeatedly to select the source which corresponds to the jack on the TV connection panel that is receiving the input signal. • Press QUIT to remove the menu. 	<ul style="list-style-type: none"> • Make sure remote is in TV mode. • Point and press on the SOURCE icon (at the top of the screen). • Point and press on the Main Source which corresponds to the jack on the TV connection panel that is receiving the input signal. • Move the pointer off the menu and press the Trackball to remove the menu. 	<ul style="list-style-type: none"> • Make sure remote is in TV mode. • Press SOURCE on your remote to view the Source Menu. • Press the Left or Right key to select PIP Source column. • Press SOURCE repeatedly to select the source which corresponds to the jack that is receiving the PIP input signal. • Press QUIT to remove the menu. 	<ul style="list-style-type: none"> • Make sure remote is in TV mode. • Point and press on the SOURCE icon (at the top of the screen). • Point and press on the PIP Source which corresponds to the jack on the TV connection panel that is receiving the input signal. • Move the pointer off the menu and press the Trackball to remove the menu.

* A PIP inset appears while the Source icon is selected to show the effect of choosing a PIP source.

PICTURE-IN-PICTURE FUNCTIONS

While using the various PIP functions, refer to the illustration below and the instructions on the following pages. Note that the operation of these functions differ, depending on which remote control you are using.

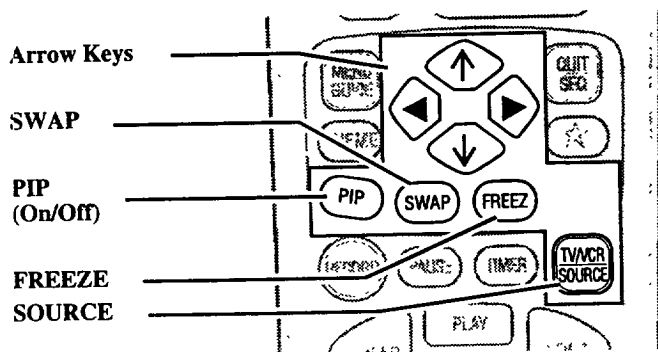

PIP Functions, Universal Remote Control

Select these options with the Z-Trak remote to perform the PIP functions described on the following page.

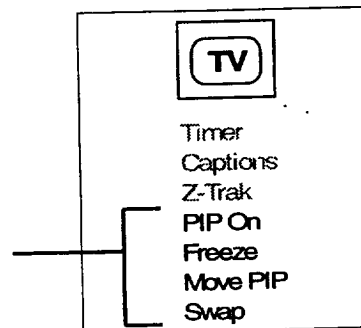

PIP Functions, Z-Trak Remote Control

continued on next page

PIP OPERATION

PIP Functions using Universal Remote	PIP Functions using Z-Trak Remote
<ul style="list-style-type: none"> • PIP On/Off: Press the PIP key to display the PIP inset. Press it again to remove the PIP inset. • SWAP: Press the SWAP key to swap the main picture with the PIP inset. Press SWAP again to return to the original display. • FREEZE: Press FREEZ to freeze motion of the picture shown in the PIP inset. Press FREEZ again to return to a live PIP inset. • PIP Size: Select PIP Size in the PIP Menu to choose between seeing a small or large PIP inset. • Moving the PIP Inset: Use the Left/Right and Up/Down arrow keys to move the PIP inset to the desired location of the TV screen. 	<ul style="list-style-type: none"> • PIP On/Off: Move pointer to left of TV screen and press on PIP On to display the PIP inset. Move the PIP inset to the desired location on the screen and press the trackball to set it in place. Press on PIP Off to remove the PIP inset. • SWAP: Move pointer to left of TV screen and press on Swap to swap the main picture with the PIP inset. Press on Swap again to return to the original display. • FREEZE: Move pointer to left of TV screen and press on Freeze to freeze motion of the picture shown in the PIP inset. Press on Freeze again to return to a live PIP inset. • PIP Size: Select PIP Size in the PIP Menu to choose between seeing a small or large PIP inset. • Moving the PIP Inset: Move pointer to left of TV screen and press on Move PIP and move the PIP inset to desired location on the screen. Press the trackball to set the inset in place.

OPERATION WITH ANTENNA OR DIRECT CABLE

This illustration shows the basic connection of your TV to a VCR. With your equipment setup in this manner, your television has the following PIP capabilities:

- Simultaneously view a video tape playing in the VCR and a channel selected by the TV's tuner.
- Simultaneously view two different channels; one selected by the TV's tuner and another using the VCR's tuner.
- Swap the main picture and the PIP inset.

PIP VIEWING OPTIONS	
Viewing Two Different Channels	Viewing a Video Tape and a TV Channel
<ul style="list-style-type: none"> • Set VCR's TV/VCR* switch to TV. • Select Ant/Cable 1 as the Main Source in the Source Menu . • Select Video 1 as the PIP Source in the Source Menu . • Select a channel with the TV's channel selector. • Turn on PIP. • Select a PIP channel using the VCR's channel selector. 	<ul style="list-style-type: none"> • Set VCR's TV/VCR* switch to TV. • Select Ant/Cable 1 as the Main Source in the Source Menu . • Select Video 1 as the PIP Source in the Source Menu . • Select a channel with the TV's channel selector. • Turn on PIP. • Play a tape in the VCR and view it in the PIP inset.
* May be labeled TV/Video.	

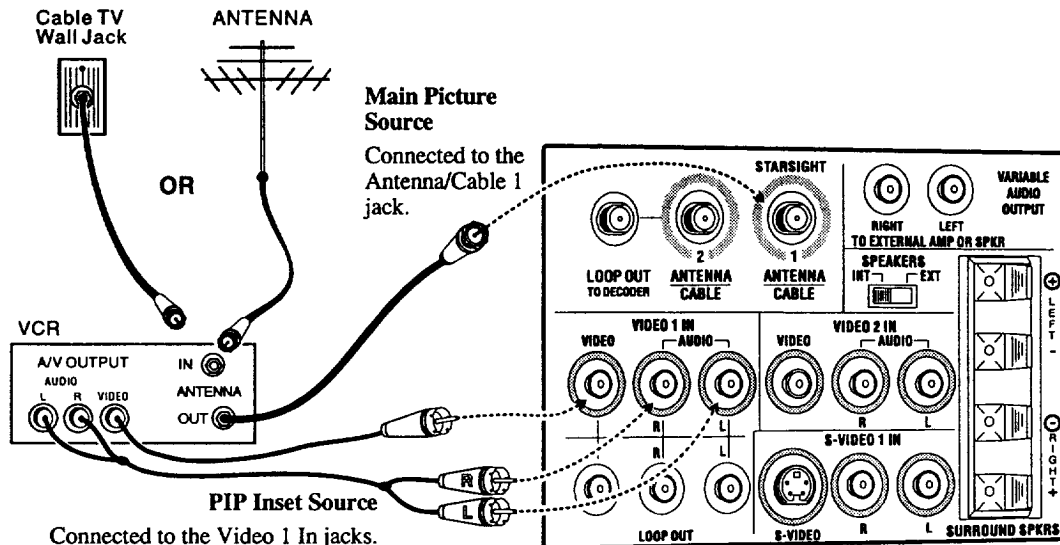

Option 1: Antenna or Direct Cable Connection To VCR.
(Cables are not supplied with television.)

PIP OPERATION

OPERATION WITH CABLE DECODER

With your equipment setup in this manner, your television has the following PIP capabilities:

- Simultaneously view a video tape playing in the VCR and a basic cable channel selected by the TV's tuner.
- Simultaneously view two different cable channels; one cable channel selected by the TV's tuner and another cable channel selected by the cable box.
- Swap the main picture and the PIP inset.

NOTE:

- The cable channels you can view depends on the service you have purchased from your cable company.

PIP VIEWING OPTIONS	
Viewing Two Different Cable Channels	Viewing a Video Tape and a Cable Channel
<ul style="list-style-type: none"> • Select Ant/Cable 2 as the Main Source in the Source Menu . • Select Video 1 as the PIP Source in the Source Menu . • Select a channel with the TV's channel selector. • Turn on PIP inset. • Select a PIP channel using the tuner in the Cable Box. 	<ul style="list-style-type: none"> • Select Ant/Cable 2 as the Main Source in the Source Menu . • Select Video 1 as the PIP Source in the Source Menu . • Select a channel with the TV's channel selector. • Turn on PIP inset. • Play a tape in the VCR and view it in the PIP inset.

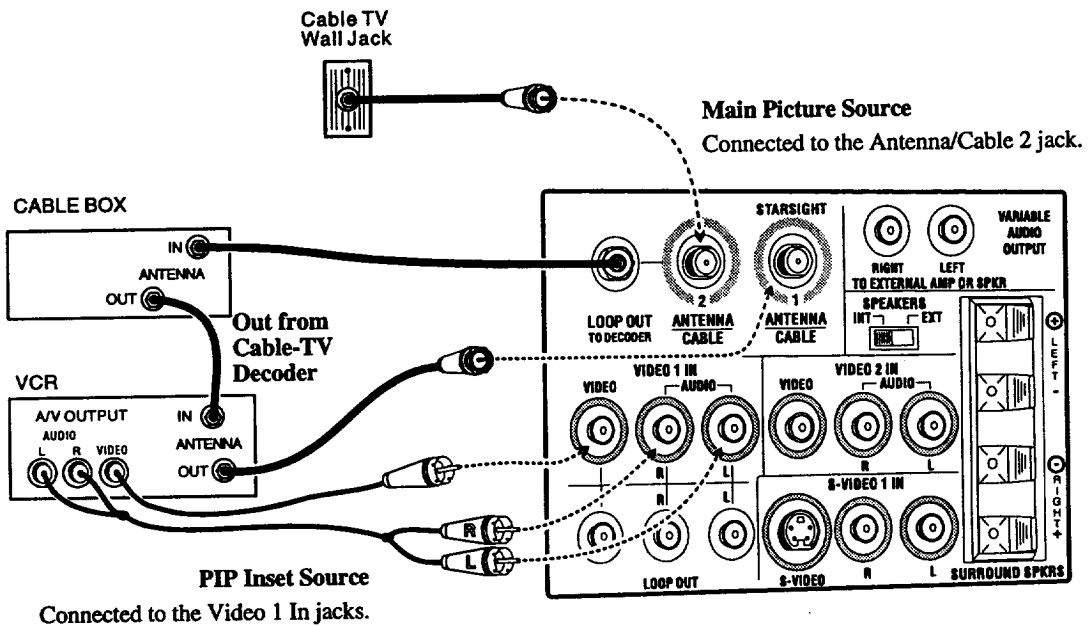

Option 2: Cable-TV Decoder Connection via Loop Out To VCR.
(Cables are not supplied with television.)

UNIVERSAL REMOTE CONTROL

INTRODUCTION

This universal remote control operates the common features of most, but not all, models and brands of IR (infrared) controlled TVs, VCRs, cable converters, video disc players, and audio equipment. The remote may provide functions that are not available on your equipment, e.g., menu operations. Some functions of your particular equipment may not be controlled by this remote. In such cases, use the original remote control for your equipment.

BATTERY INSTALLATION

Batteries are provided, but must be installed before using the remote control. When it no longer functions normally, or when it loses memory, replace the batteries with two high-quality, alkaline, size AAA batteries. Match plus with plus (+ with +), minus with minus (- with -) in the battery compartment.

Unless your equipment responds to the factory preset codes, i.e., 101 for TV, 201 for VCR, 353 for CABLE, and 401 for AUX., you will need to reprogram the remote with the codes of your particular equipment after you replace batteries.

NOTES:

- Do not place heavy objects on top of the remote control keys. Prolonged unintentional operation of the remote shortens battery life.
- Remove the batteries if the remote control will not be used for a month or more. **THE MANUFACTURER IS NOT RESPONSIBLE FOR DAMAGE CAUSED BY BATTERY LEAKAGE.**

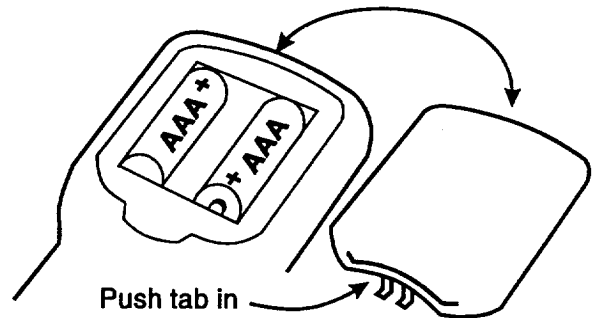

CHOOSING OPERATING MODE

To control your TV, VCR, cable box, or auxiliary equipment with this remote, you must first choose the mode of operation. Press the desired mode key for TV, VCR, CABLE or AUX. Pressing the ★ (Star) key will put the remote into StarSight mode. Press TV to return to TV mode. Some keys on the remote will always operate a particular product function. For example, VOLUME controls the TV sound level, and PLAY controls the VCR play function.

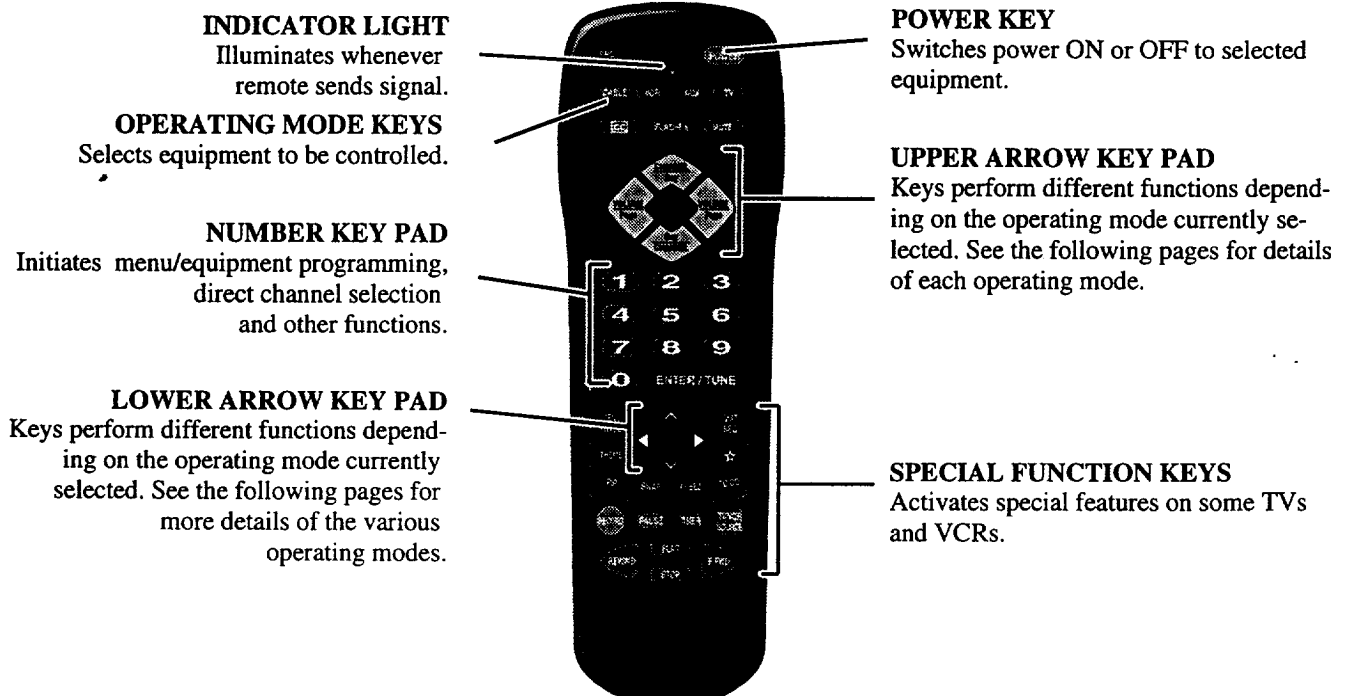

UNIVERSAL REMOTE CONTROL

TV OPERATIONS

These descriptions apply to functions and operations of your TV. First, press the TV button on the remote control to select the TV mode of operation.

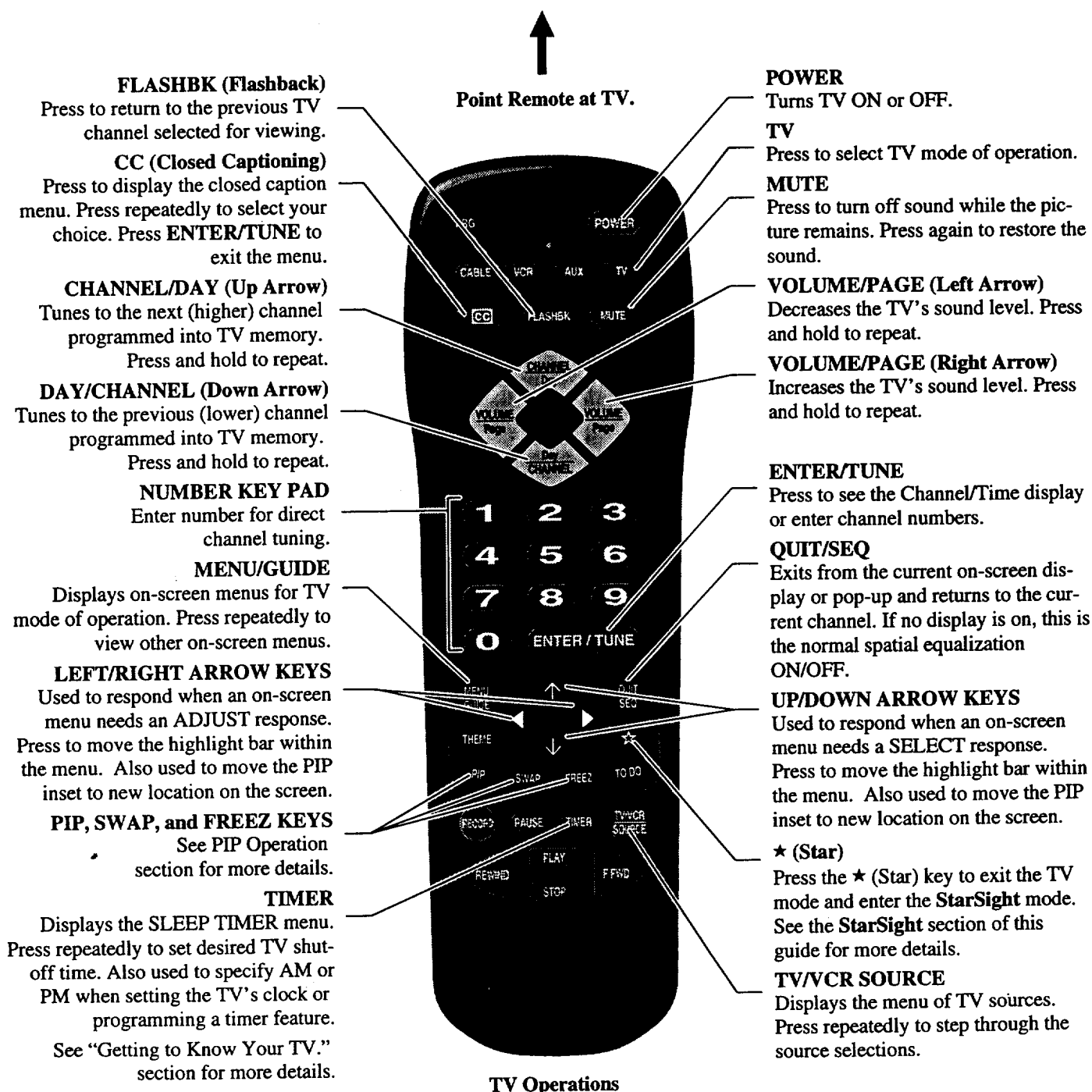

NOTE:

- Keys dedicated to VCR functions may be used to operate your VCR while the remote is in TV mode.

UNIVERSAL REMOTE CONTROL

OPERATIONAL MODES FOR FACTORY PRESET CODES

Push-button or Key Label	TV Mode Code 101	StarSight Mode accessed with ★	VCR Mode Code 201	Cable Mode Code 353	AUX Mode Code 401
POWER	TV Power On/Off	Star Power On/Off	VCR Power On/Off	Cable Power On/Off	AUX TV/Disc
CABLE	Selects Cable Mode	Selects Cable Mode	Selects Cable Mode	Selects Cable Mode	Selects Cable Mode
VCR	Selects VCR Mode	Selects VCR Mode	Selects VCR Mode	Selects VCR Mode	Selects VCR Mode
AUX	Selects AUX Mode	Selects AUX Mode	Selects AUX Mode	Selects AUX Mode	Selects AUX Mode
TV	Selects TV Mode	Selects TV Mode	Selects TV Mode	Selects TV Mode	Selects TV Mode
CC	TV Closed Captions	TV Closed Captions	VCR AM/PM	CABLE FC (Favorite Ch.)	AUX Audio
FLASHBK	TV Flashback	StarSight Flashback	VCR Flashback	CABLE Flashback	AUX Frame/Time
MUTE	TV Mute	StarSight Mute	TV Mute	TV Mute (See Note 1)	TV Mute
CHANNEL/DAY UP	TV Channel Up	StarSight CH/Day Up	VCR Channel Up	CABLE Channel Up	AUX Skip >>
CHANNEL/DAY DN	TV Channel Dn	StarSight CH/Day Dn	VCR Channel Dn	CABLE Channel Dn	AUX Skip <<
VOLUME/PAGE UP	TV Volume Up	StarSight Vol/Page Up	TV Volume Up	TV Volume Up (See Note 1)	TV Volume Up
VOLUME/PAGE DN	TV Volume Dn	StarSight Vol/Page Dn	TV Volume Dn	TV Volume Dn (See Note 1)	TV Volume Dn
1	TV Digit 1	StarSight Digit 1	VCR Digit 1	CABLE Digit 1	AUX Digit 1
2	TV Digit 2	StarSight Digit 2	VCR Digit 2	CABLE Digit 2	AUX Digit 2
3	TV Digit 3	StarSight Digit 3	VCR Digit 3	CABLE Digit 3	AUX Digit 3
4	TV Digit 4	StarSight Digit 4	VCR Digit 4	CABLE Digit 4	AUX Digit 4
5	TV Digit 5	StarSight Digit 5	VCR Digit 5	CABLE Digit 5	AUX Digit 5
6	TV Digit 6	StarSight Digit 6	VCR Digit 6	CABLE Digit 6	AUX Digit 6
7	TV Digit 7	StarSight Digit 7	VCR Digit 7	CABLE Digit 7	AUX Digit 7
8	TV Digit 8	StarSight Digit 8	VCR Digit 8	CABLE Digit 8	AUX Digit 8
9	TV Digit 9	StarSight Digit 9	VCR Digit 9	CABLE Digit 9	AUX Digit 9
0	TV Digit 0	StarSight Digit 0	VCR Digit 0	CABLE Digit 0	AUX Digit 0
ENTER/TUNE	TV Enter	StarSight Enter/Tune	VCR Enter	CABLE Enter	AUX Display
MENU/GUIDE	TV Menu	StarSight Guides	VCR Menu	CABLE Menu	AUX Program
THEME	(No Function)	StarSight Theme	(No Function)	(No Function)	(No Function)
UP ARROW	TV Select Up	StarSight Select Up	VCR Select Up	CABLE Up Arrow	AUX Part
DOWN ARROW	TV Select Dn	StarSight Select Dn	VCR Select Dn	CABLE Down Arrow	AUX Random
LEFT ARROW	TV Adjust Left	StarSight Adjust Left	VCR Adjust Left	CABLE Left Arrow	AUX x3 FAST <
RIGHT ARROW	TV Adjust Right	StarSight Adjust Right	VCR Adjust Right	CABLE Right Arrow	AUX x3 FAST >
QUIT/SEQ	TV SEQ Sound/Quit	StarSight Quit	VCR Quit	CABLE Quit	AUX Clear
★ (Star)	Enters StarSight Mode	Enters StarSight Mode	Enters StarSight Mode	Enters StarSight Mode	Enters StarSight Mode
PIP	TV PIP On/Off	StarSight PIP On/Off	VCR VCR+	CABLE Day Up	AUX Repeat-Side
SWAP	TV PIP Swap	TV PIP Swap	VCR Channel Map	CABLE Day Down	AUX Repeat-A-B
FREEZ	TV PIP Freeze	TV PIP Freeze	VCR Search	CABLE Pg Up/★	AUX Repeat-Chap
TO DO	(No Function)	StarSight To Do	VCR Memory	CABLE Pg Dn/#	AUX Memory
TIMER	TV Timer	TV Timer	VCR Timer	CABLE Timer	AUX Still ><
TV/VCR/SOURCE	TV Source	TV Source	VCR TV/VCR Tuner	CABLE Info	AUX TV/Disc
RECORD	VCR Record	StarSight VCR Record	VCR Record	CABLE Buy	AUX Edit
PAUSE	VCR Pause	VCR Pause	VCR Pause	CABLE Guide	AUX Pause
REWIND	VCR Rewind	VCR Rewind	VCR Rewind	VCR Rewind	AUX Scan <<
PLAY	VCR Play	VCR Play	VCR Play	VCR Play	AUX Play
STOP	VCR Stop	VCR Stop	VCR Stop	VCR Stop	AUX Stop/Eject
FFWD	VCR Fast Forward	VCR Fast Forward	VCR Fast Forward	VCR Fast Forward	AUX Scan >>

NOTES:

1. Can be overwritten with Cable Vol/ Mute when 399 is entered.

Reference: 124-205-05 and

µP 221-879-03

UNIVERSAL REMOTE CONTROL

PROGRAMMING YOUR REMOTE

If you are using Zenith products, the remote is programmed for the most commonly used codes. For other brands — or if your remote fails to control your Zenith products — you will have to program the remote.

Follow these steps for each product you are using:

1. Look up the three-digit code for your brand (such as Zenith) and type of equipment (such as VCR) in the code table on the following page.
2. Press and hold **PRG** with a small blunt object until the indicator lights (about three seconds).
3. Press **TV**, **VCR**, **CABLE**, or **AUX** to select the product you want your remote to control. (Use **CABLE** or **AUX**, to program your remote for a second TV or VCR or to program your remote for a video disc player or audio equipment.)

4. Key in the three-digit code for your equipment, then press **ENTER/TUNE**. The indicator light should flash, then turn off to indicate that the code was accepted. If the indicator stays on, repeat steps 3 and 4 or try using a different code.
5. Write the codes that operate your equipment on the label inside the battery compartment for future reference.

To erase all code programming and return to the factory preset codes, key in code **9-1-1** when programming the remote.

NOTES:

- The remote cannot be programmed while in the **StarSight** mode: Choose **TV**, **VCR**, **CABLE** or **AUX** mode before pressing **PRG**.
- If no key on your remote is pressed within 60 seconds, the programming process will stop, and you will have to start again.
- You may cancel programming at any time by pressing **PRG**.

SPECIAL FEATURES

AUX+1, AUX+2, AUX+3 Capability

Your remote can control up to seven electronic components. If you have programmed the remote for four components using the **TV**, **VCR**, **CABLE** and **AUX** keys, you may also program it for up to three additional components (**AUX+1**, **AUX+2**, **AUX+3**) by **holding** the **AUX** key and pressing the **1**, **2** or **3** key during programming. Once programmed, hold down the **AUX** key and press **1**, **2** or **3**, to access the additional **AUX +1**, **2** or **3** mode.

Cable Box Volume

You may use your remote to control cable box volume and muting if available on your equipment. First program your remote with the brand code for your cable device using the **CABLE** or **AUX** key. Then repeat the programming steps, again using the **CABLE** or **AUX** key, but key in code **3-9-9** instead of a brand code.

To restore TV volume/mute control to the **CABLE** or **AUX** mode, reprogram your cable code into that mode.

Amplifier Volume Override

You may use your remote to override your TV, VCR or video disk player's volume functions with your amplifier's volume and muting.

1. Program your amplifier code into the **CABLE** mode or one of the **AUX** modes.
2. Select the mode on your remote (**TV**, **VCR**, etc.) where you want the **amplifier** volume control function to appear. In other words, if you want to operate the volume and mute of your amplifier while the remote is in **TV** mode, press **TV** for this step.
3. Begin the programming steps as described in "Programming Your Remote" and enter code **4-9-9**, followed by **ENTER**.

The amplifier volume and mute features are now available in the current mode.

To restore normal volume and muting control to your TV, VCR, cable or laser disc player, reprogram the remote for these units into each mode (**TV**, **VCR**, etc.) to be restored.

NOTE:

- CD and tape devices will automatically select amplifier volume and mute.

UNIVERSAL REMOTE CONTROL

AUTO FIND OPTION

If you have tried all the codes listed for your brand and type of product in the code table, and none of those codes operate your equipment, you can use Auto Find to search for the code you need.

Follow these steps for each product you are using:

1. Turn the product ON and aim the remote toward it.
2. Press and hold **PRG** with a small blunt object until the indicator lights (about three seconds).
3. Press the mode key on the remote for the product you want to control: **TV**, **VCR**, **CABLE**, or **AUX**.
4. Key in code **0-0-0**, then press **ENTER** within two seconds. When the indicator light flashes three times and remains lit, Auto Find is active.

5. Press and hold **POWER**, then release it, repeating this action about once a second until the product turns OFF.
6. Press **ENTER** immediately to save the code. If your remote fails to operate the functions you use most often, you can re-enter Auto Find and search for a better code.

NOTES:

- The indicator light should flash OFF when you press **POWER** and back ON when you release it. If the indicator light stays on when you press **POWER**, Auto Find has tried all available codes. If you finish Auto Find and the product you want to control has not turned off, your remote cannot control that product.
- Pressing **PRG** at any time during the use of Auto Find will cancel Auto Find, and you will have to start again.

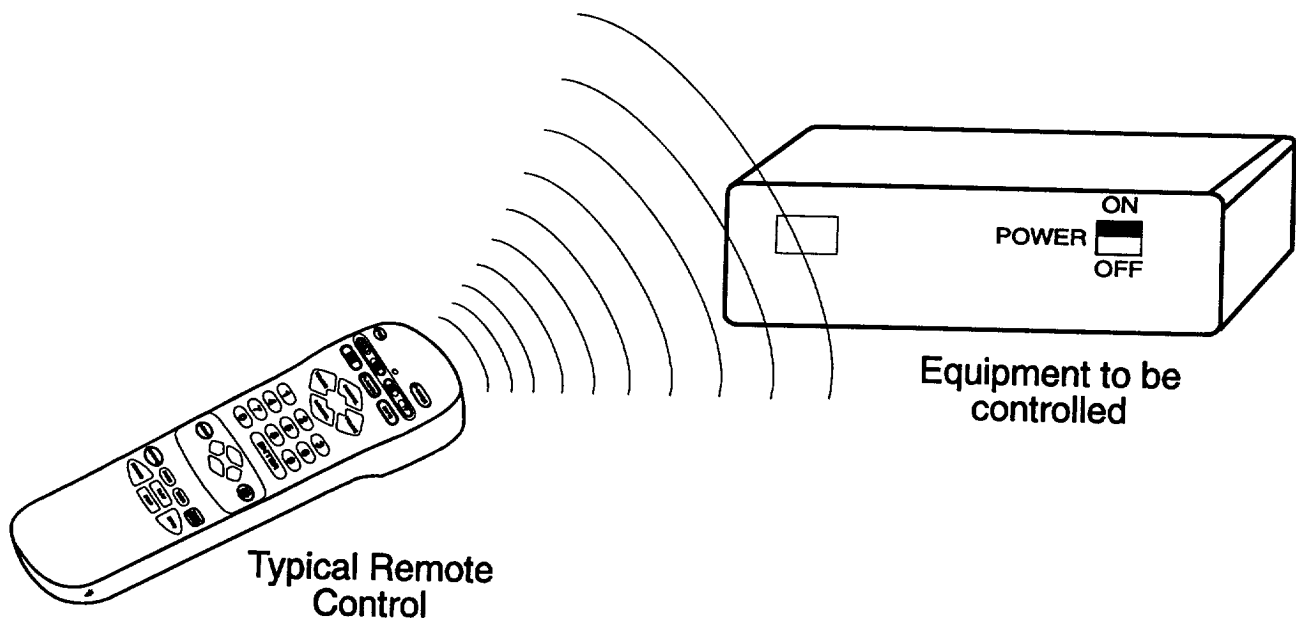

UNIVERSAL REMOTE CONTROL

OPERATING CODES BY BRAND NAME

TVS	
Admiral	116, 121, 130, 133
Adventura TV/VCR	154
Akai	104
Amark	103, 146
AOC	104
Bell & Howell	121
Broksonic	131, 136
Candle	139
Centurion	119
Citizen	121, 139
Contec	141
Coronado	103
Crown	103
Curtis Mathes	116, 119, 121
Daewoo	149, 159
Daewoo TV/VCR	148
Daytron	119
Elektra	121
Emerson	103, 104, 123, 124, 131, 136, 145
Emerson TV/VCR	158
Fisher	109, 118
Funai TV/VCR	154
General Electric	106, 107, 114, 116, 117, 161
Goldstar	103, 104, 119, 147
Goldstar TV/VCR	153
Hitachi	102, 103, 129, 163
J.C. Penney	104, 110, 114, 117, 119
JVC	125, 132, 164
KMC	103
KTV	103, 104, 138
Kurazai	121
Lodgenet	121
Logik	121
LXI	133, 137
Magnavox	103, 112, 113, 117, 119, 127, 128, 139, 165
Magnavox TV/VCR	173
Majestic	121
Marantz	104, 120, 155
Megatron	146
Memorex	121
MGA/ Mitsubishi	104, 119, 120, 130, 140, 155
Montgomery Ward	103, 104, 105, 113, 114, 119, 121, 130, 133
NEC	104, 119
Panasonic	106, 107, 160, 166
Panasonic TV/VCR	174
Philco	103, 104, 112, 113, 139
Philips	112, 113
Pioneer	135
Portland	103
ProScan	116, 157, 162, 167

Quasar	106, 107
RCA	104, 116, 126, 157, 161, 162, 167, 168
Realistic	105, 123, 124
Sampo	119
Samsung	103, 119, 134, 141
Sanyo	108, 109, 118
Scott	119, 124
Sears	103, 108, 109, 110, 111, 118, 134
Sharp	103, 105, 122, 133, 137, 156, 169
Signature 2000	103, 104, 105, 113, 114, 119, 121, 130, 133
Sony	115, 143, 151, 170
Soundesign	139
Sylvania	112, 113, 117, 119, 127, 128, 139
Symphonic TV/VCR	154
Tatung	106
Teknika	103, 112, 121, 124, 139
Telerent	103, 121
Toshiba	110, 111, 134, 171
XR1000	121
Yorx	119
Zenith	101, 149
Zenith TV/VCR	153, 154, 172

VCRS	
Admiral	208, 261
Adventura	231
Arwa	231
Akai	223, 238, 241
Audio Dynamics	202, 218
Bell & Howell	206, 247
Broksonic	221, 226, 250, 255
Canon	214
Citizen	209
Craig	212
Curtis Mathes	214, 259
Daewoo	244, 246, 248, 254
Daytron	236, 246
DBX	202, 218
Emerson	203, 221, 223, 226, 233, 235, 243, 250
Fisher	211, 212, 213, 247
Funai	231
General Electric	214, 216, 220
Goldstar	209
Go Video	256, 262, 263
Hitachi	215, 257
Instant Replay	214, 227
J.C. Penney	214, 215, 218, 227
JVC	202, 225, 258
Kenwood	202
Logik	239
LXI	209, 231

Magnavox	207, 214, 231
Marantz	207, 218
Marta	209
Memorex	206, 212, 214, 231
Mitsubishi	204, 222, 252
Montgomery Ward	208, 214, 216, 219, 231, 249
Multi Tech	239
NEC	202, 218
Orion	250
Panasonic	214, 251, 259
Pentax	215
Philco	207, 214
Philips	207, 214, 227
Pioneer	210, 215
Portland	246
Pro Scan	216, 260
Quasar	214, 259
RCA	215, 216, 220, 227, 240, 242, 260
Realistic	206, 208, 212, 214, 231
Samsung	220, 230
Sansui	239
Sanyo	206, 212, 247
Scott	204, 205, 233, 243
Sears	206, 209, 211, 212, 215
Sharp	208, 261
Shintom	239
Signature 2000	208, 214, 216, 219, 231, 249
Sony	217, 232, 237
Sylvania	207, 214, 227
Symphonic	231
Tashiko	209
Tatung	202
Teac	202, 231
Teknika	234
Toshiba	205, 215
XR1000	239
Vector Research	204, 218
Yamaha	202, 218
Zenith	201, 224, 225, 229, 237

CABLE/SATELLITE	
Allegro	358, 362
Allegro A/B Switch	361
Gemini	305, 331, 338
General Electric	367
General Instrument	305, 306
Hamlin	302, 303, 345, 365, 366
Jerrold	304, 307, 308, 309, 310, 318, 360, 363
Kale Vision	335
Macom	314, 321
Magnavox	334
NSC	335, 339, 368, 369, 370

Oak	311, 332, 342
Panasonic	313, 320
Paragon	333
Philips	347, 350, 352, 354, 355
Pioneer	315, 343
RCA DSS	373
Regency	329
Samsung	335
Scientific Atlanta	316, 323, 336, 364
Sprucer	313
Standard Comp	335
Texscan	339, 356, 371
Tocom	317, 318, 346
Unika	348, 362
United Satellite	344
Universal	358, 362
Vid Tech	340
Video Way	349
Viewstar	354, 355, 372
Zenith	301, 353
Zenith Satellite	312, 328, 330, 351

VIDEO DISK PLAYERS	
Pioneer	402, 403
Sanyo	401
Sony	404
Zenith	401

AUDIO CD PLAYERS	
Akai	409, 424
Crown	410
Denon	411
Fisher	412, 438
Goldstar	460
Harman/Kardon	413
JVC	415
Kenwood	412, 416, 417, 441
Magnavox	421, 422, 433, 434
Mitsubishi	423, 424
NAD	425, 426, 447
Nakamichi	427, 428
NEC	429
Onkyo	430
Panasonic	431, 432
Philips	421, 433, 434
Pioneer	431, 435
Quasar	432
Radio Shack	431, 436, 439, 440, 441
RCA	437
Sanyo	438, 439
Scott	440
Sharp	441, 442
Sony	443, 444, 445
Soundesign	461, 498, 501, 502

Teac	446
Technics	432, 459
Toshiba	447
Yamaha	448
Zenith	460, 461, 498, 501, 502

AUDIO TAPE DECKS	
Denon	455
Harman/Kardon	456
JVC	457
Kenwood	450
Onkyo	458
Philips DCC	454
Pioneer	451, 478
Sony	452
Technics	454, 497
Yamaha	453

AUDIO TUNERS AND AMPLIFIERS	
Denon	462, 463
Fisher	464
Goldstar	460
Harman/Kardon	465
JVC	466
Kenwood	468, 469
Marantz	472, 503
Onkyo	473
Philips	475, 476
Pioneer	477, 478, 479
Radio Shack	487, 488
Realistic	480
Sanyo	481
Scott	482
Sharp	483
Sherwood	487, 488
Sony	489, 490, 491, 492
Soundesign	461, 498, 501, 502
Teac	494, 495
Technics	497
Yamaha	496
Zenith	460, 461, 498, 501, 502

Ref: 124-205-05 and
µP 221-879-03

QUICK REFERENCE TO MENUS: UNIVERSAL REMOTE

AVAILABLE MENUS

Your TV is icon and menu operated. In other words, an icon is selected at the top of the TV screen and a menu of adjustment options appears.

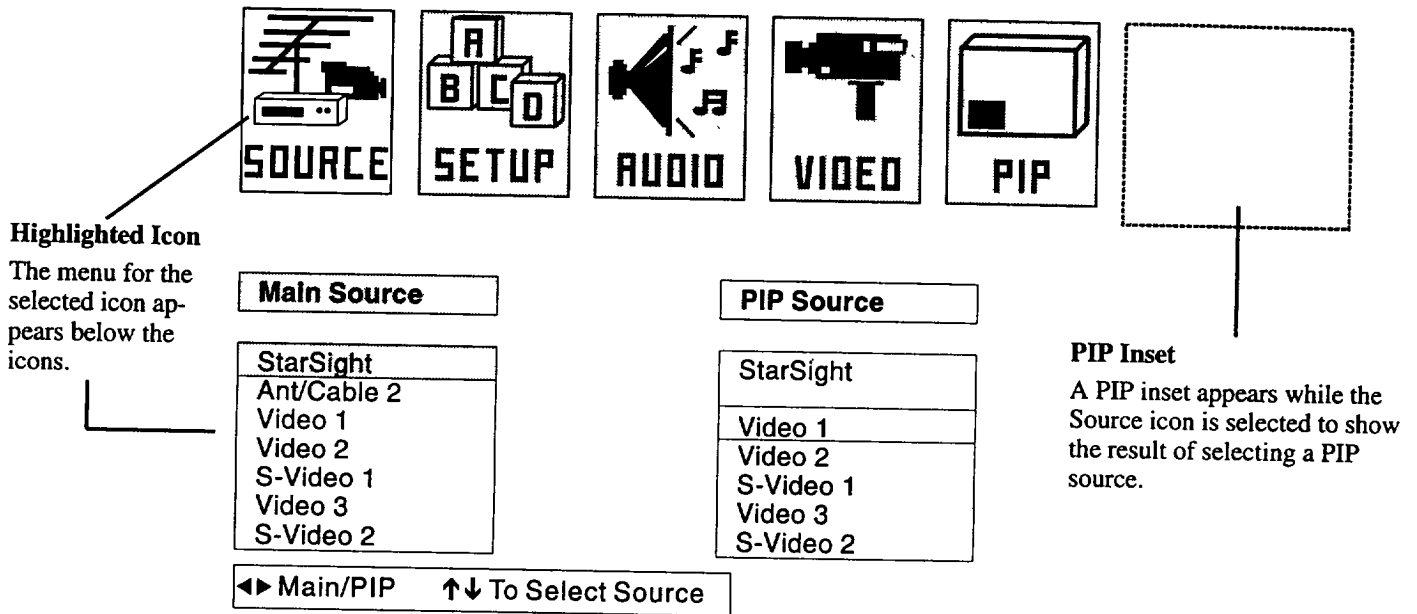

BASIC MENU OPERATION

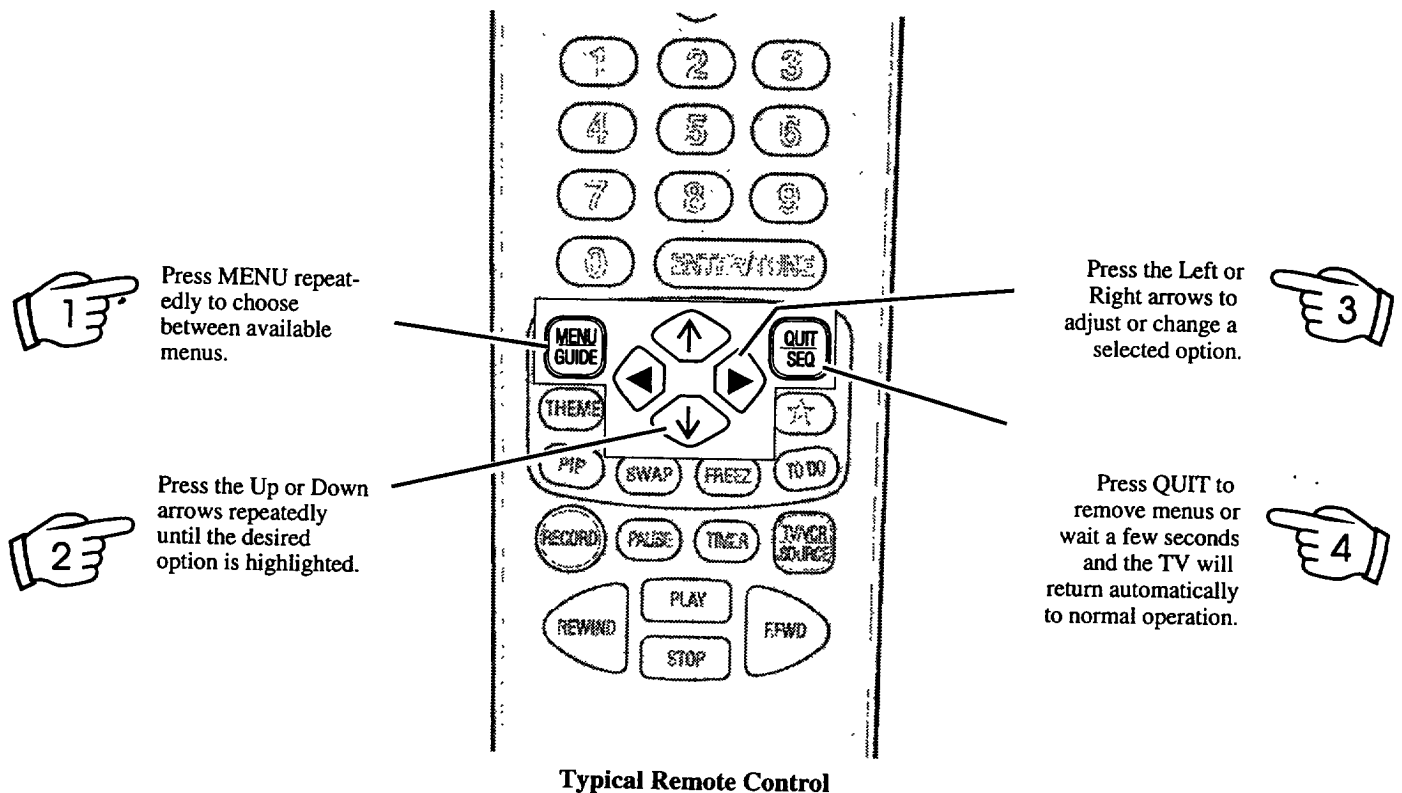

SOURCE MENU

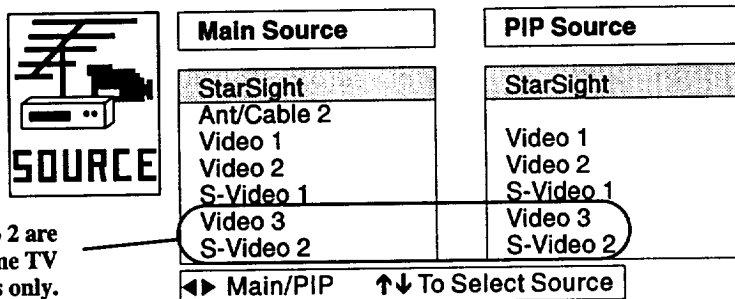

Video 3 and S-Video 2 are source options for some TV models only.

A PIP inset appears while the Source icon is selected to show the effect of choosing a PIP source.

If the PIP Source is changed, the PIP inset will remain on the screen after you exit from menu operations.

MENU OPERATION

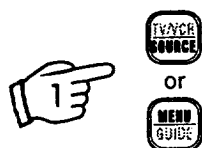

Press SOURCE for direct entry to the Source Menu, or press MENU repeatedly until the Source Menu is selected.



Press SOURCE repeatedly until the desired Source is selected.



Press the Left/Right keys to select either Main Source column or PIP Source column.



Press QUIT or wait a few seconds for the TV to return to normal operation.

SOURCE SELECTION

ANT/CABLE 1 or 2	Routes the antenna or cable-TV source to the TV for viewing. You see program material from whichever signal source is connected to the ANT/CABLE 1 or 2 jack. (If the signal is from a VCR or a cable box, tune the TV to either channel 3 or 4.)
VIDEO 1, 2 or 3	Routes the audio and video from an A/V source (such as a VCR or a video disc player) to the TV for viewing. The source must be connected to the corresponding VIDEO 1, 2 or 3 IN jacks.
S-VIDEO 1 or 2	Routes the audio and video from an auxiliary Super-VHS video source (such as a VCR or a video disc player) to the TV for viewing. The source must be connected to the corresponding S-VIDEO 1 or 2 IN jacks.

Refer to the "Standard Connections for Your TV" section to make the proper equipment connections to the TV. For information about PIP sources, refer to the "PIP Operation" section.

SOURCE IDENTIFICATION

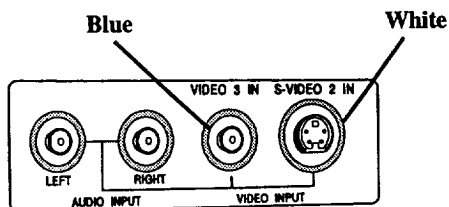

Auxiliary A/V Jacks (Some TV Models)

NOTE:

- The color of the Channel/Time display corresponds to the color rings around the connectors of the jack panels. For example, the Channel/Time display will be Red if you are watching a program on Ant/Cable 1 source.

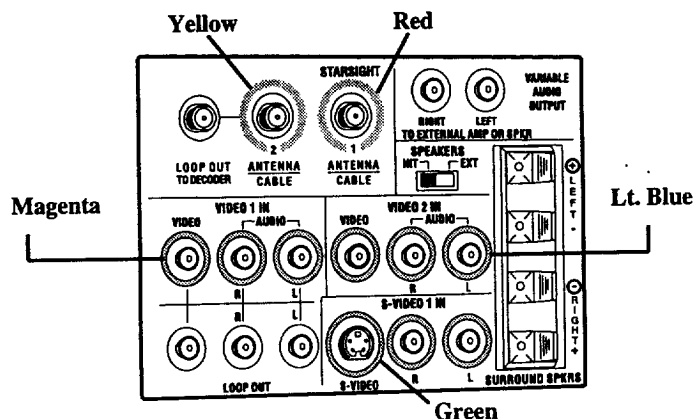

Connection Center on Back of TV

SETUP MENU

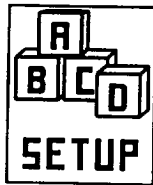

Auto Program
Ch. Add/Del
Ch. Labels
Source ID
Clock Set
Timer Setup
Parental Ctl
Caption/Text
Background
StarSight

Press ◀▶ To Program

Source ID
Clock Set
Timer Setup
Parental Ctl
Caption/Text
Background

Press ◀▶ To Label Sources

While Video or Super-Video Source is Chosen

MENU OPERATION



Press MENU repeatedly until the SETUP MENU is shown.



Press the Left/Right keys to adjust the selected option.



Press the Up/Down keys until the desired option is selected.



Press QUIT or wait a few seconds for the TV to return to normal operation.

Auto Program	Finds all active channels and stores them in the TV's memory for use by CHANNEL up/down. See "THE FIRST TIME YOU OPERATE YOUR TV" for more details.
Ch. (Channel) Add/Del	Edits the channels found by Auto Program to create your own personal list of favorite channels. See the information following this chart for more details.
Ch. (Channel) Labels	Assigns a network/station label, name or call letters to specified channels. For example, if you choose the label "ABC" for channel 9, then "ABC" will appear in the Channel/Time display whenever channel 9 is selected. See the information following this chart for more details.
Source ID	Assigns a descriptive "name" to the input sources. For example, the Video 1 source may be named VCR. "VCR" will now appear in the Source Menu as a reminder that your VCR is connected to the Video 1 input jacks.
Clock Set*	Sets the clock in the TV to the correct time. Press the Left/Right arrow keys to advance the 24-hour clock, or use numbered buttons on the remote to enter time. Press ENTER to start the clock.
Timer Setup	Sets the TV's Sleep Timer and On/Off Timer features. See the information following this chart for more details.
Parental Ctl. (Control)	Use this feature to block viewing of any undesirable channels or an entire input video source. See the information following this chart for more details.
Caption/Text	Displays closed captioning or informational text when available on the selected channel. Options are: OFF, CAPTION 1, CAPTION 2, CAPTION 3, CAPTION 4, TEXT 1, TEXT 2, TEXT 3, or TEXT 4. See the information following this chart for more details.
Background	Adds or removes a solid-color background behind the on-screen menus.
StarSight	Begins the StarSight setup procedure. Refer to the StarSight section of this guide for details.

continued on next page

SETUP MENU

USING CH. (CHANNEL) ADD/DEL

Add Channels to Scan	Delete Channels from Scan
<ul style="list-style-type: none"> Press the Up/Down keys to select Ch. Add/Delete. Press Left/Right keys to view the add/delete screen. Use the Left/Right and Up/Down keys to move selector to the channel being added. Add the channel by pressing SOURCE until the display shows Added. 	<ul style="list-style-type: none"> Press the Up/Down keys to select Ch. Add/Delete. Press Left/Right keys to view the add/delete screen. Use the Left/Right and Up/Down keys to move selector to the channel being deleted. Delete the channel by pressing SOURCE until the display shows Deleted.

NOTES:

- Ch. Add/Del can only be used with ANT/CABLE 1 or 2 Source.
- The audio of deleted channels is muted.

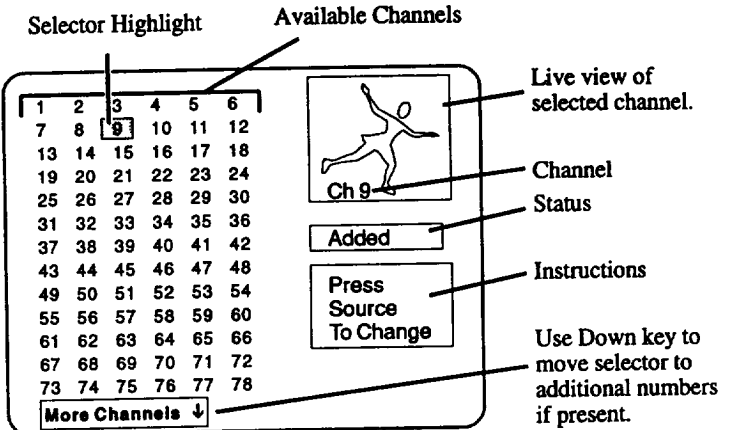

Available channels are:

Broadcast Band — VHF 2 to 13, UHF 14 to 83
Cable-TV Band — 1 to 139

USING CHANNEL LABELS

Assign Labels	Remove/Prevent Labels
<ul style="list-style-type: none"> Press the Up/Down keys to select Ch. Labels. Press Left/Right keys to view the Channel Label screen. Select a channel by pressing the CHANNEL Up/Down keys. Use the Left/Right and Up/Down keys to move selector to the desired label. 	<ul style="list-style-type: none"> Press the Up/Down keys to select Ch. Labels. Press Left/Right keys to view the Channel Label screen. Select a channel by pressing the CHANNEL Up/Down keys. Use the Left/Right and Up/Down keys to move selector to the four dashes or NONE.

NOTE:

- Ch. Labels can only be used with ANT/CABLE 1 or 2 Source.
- Selecting the four dashes (- - -) specifies that no channel label is assigned. Or, in addition to not assigning a label, **NONE** blocks the station or network labels that are transmitted by some television stations.

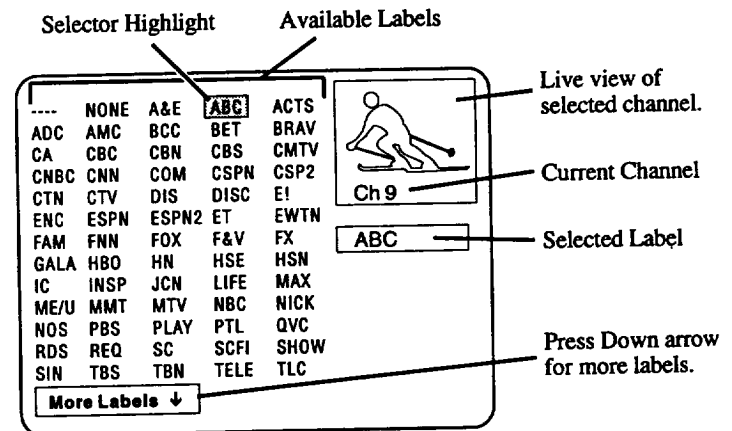

USING SOURCE ID

Assign Names To Your Sources
<ul style="list-style-type: none"> In the Setup Menu, press the Up/Down keys to select Source ID. Press the Left/Right keys to view the Source ID screen. Press the Up/Down keys to choose a Source. Press the Left/Right keys to Label the chosen Source.

VIDEO GAMES AND OTHER FIXED PATTERN DISPLAY CAUTION

If you use your TV for video games or other fixed displays, avoid setting the **BRIGHTNESS** control for an excessively bright picture. A bright, fixed pattern, if used for long periods of time, can result in a permanent imprint on the TV picture tube. You can reduce this possibility by alternating the use of the fixed pattern display with normal TV picture viewing, by turning down the **CONTRAST** control for sustained fixed pattern use, and by turning off the fixed pattern display when not in use.

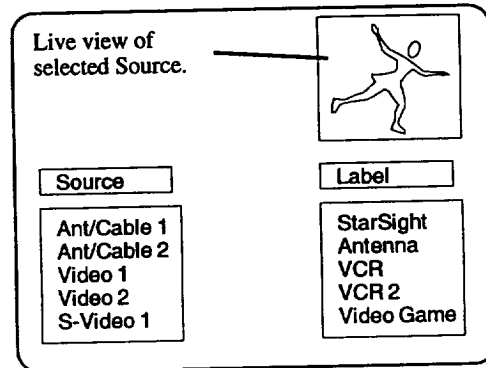

NOTE:

- Disabling a Source prevents it from appearing in the Source Menu.

Optional names for ANT/CABLE 1 or 2 Sources are:

---, Disabled, Antenna, Cable, Cable Box, Satellite, VCR, StarSight (Ant/ Cable 1 only).

Optional names for VIDEO Sources are:

---, Disabled, VCR, VCR2, Camcorder, Video Game, Laser Disc, Audio Only, Satellite (some models only).

SETUP MENU

TIMER SETUP: Sleep Timer

The Sleep Timer programs the TV to automatically turn itself off after a period from 15 minutes up to 4 hours.

From Setup Menu	Direct Access
<ul style="list-style-type: none"> • Make sure the TV's clock is set. • Press the Up/Down keys to select Timer Setup and view the Timer Menu. • Press the Up/Down keys to select Sleep Timer. • Use the Left/Right keys to set the period of time the TV will remain on. 	<ul style="list-style-type: none"> • With no menus showing on the TV, press TIMER on your remote to directly access the Sleep Timer. • Press TIMER repeatedly to set the period of time the TV will remain on.
<ul style="list-style-type: none"> • One minute before the TV turns off, the GOOD NIGHT display appears on the screen. At this time you have a choice of the following two actions. • Do nothing. The GOOD NIGHT display remains on the screen. The TV will turn off in one minute. • Delay the turn-off by resetting the timer with a new time period. 	

NOTES:

- To cancel the Sleep Timer, turn off the TV or press **TIMER** repeatedly until **OFF** is showing.
- As the Good Night display counts down the final 60 seconds, the audio and video of the TV also "dim" for a soft, discreet turn-off.

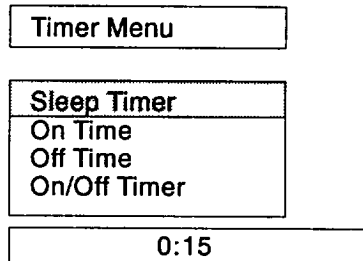

Timer Set to Turn TV OFF in 15 Minutes

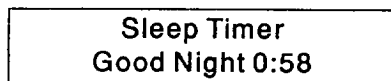

"Good Night" Display Appears 60 Seconds Before Shut-Off

TIMER SETUP: On/Off Timer

The On/Off Timer programs the TV to automatically turn itself on at a specific time then turn itself off at another time.

Set On/Off Timer
<ul style="list-style-type: none"> • Make sure the TV's clock is set. • Press the Up/Down keys to select Timer Setup • Press Up/Down keys to select On Time and use the numbered buttons on your remote to enter a time for the TV to turn itself ON. Press TIMER on the remote to select AM or PM. (You can also use the Left/Right keys to advance the time.) • Press Up/Down keys to select Off Time and use the numbered buttons on your remote to enter a time for the TV to turn itself OFF. Press TIMER on the remote to select AM or PM. (You can also use the Left/Right keys to advance the time.) • Press Up/Down keys to select On/Off Timer and use ADJUST on remote to turn timer ON (or OFF).

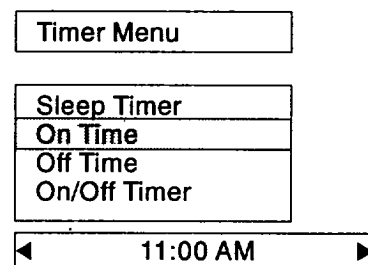

On/Off Timer Set to Turn TV ON at 11:00 am

NOTE:

- A time must be set for either On Time or Off Time in order to turn the timer ON.

SETUP MENU

USING PARENTAL CONTROL (PC)

Period of time PC will be active.

Blocks entire source.

Blocks individual channels for Ant/Cable 1 or 2 sources. (Does not appear if the entire Ant/Cable source is blocked by Block Source.)

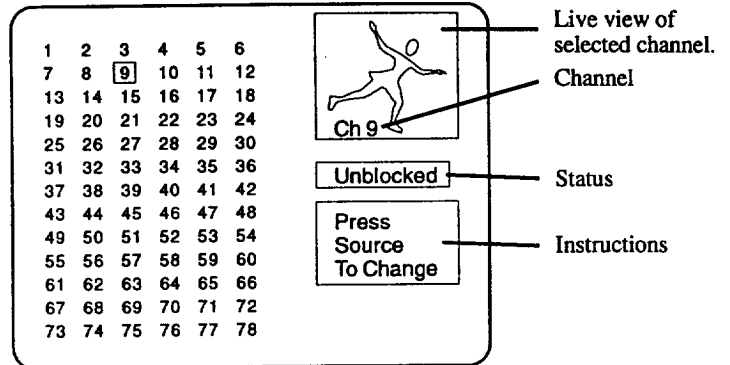
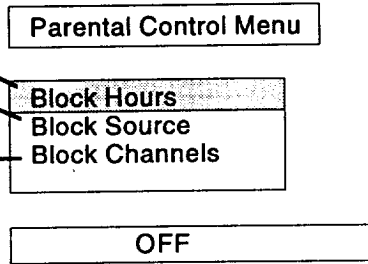

Block Entire Source	Block Individual Channels (Ant/Cable 1 or 2 Sources Only)	Re-enter PC While it is Activated
<ul style="list-style-type: none"> Press the Up/Down keys to select Parental Ctl and press the Left/Right keys to view the PC Menu. Select Block Hours and use Left/Right keys to set the length of time PC will be active: OFF, 12, 24, 48 or 72 hours. Select Block Source and use Left/Right keys to "Block" the current input source. To block other sources, press the SOURCE key and set them to "Block." Press ENTER to exit and enter any 4-digit "Parental Access Code" when prompted to do so. (You will be prompted to verify the number by entering it a second time.) 	<ul style="list-style-type: none"> Press the Up/Down keys to select Parental Ctl and press the Left/Right keys to view the PC Menu. Select Block Hours and use Left/Right keys to set the length of time PC will be active: OFF, 12, 24, 48 or 72 hours. DO NOTHING WITH BLOCK SOURCE. Select Block Channels. Use Left/Right and Up/Down keys to select a channel and press the SOURCE key to set it to "Block." Repeat this for each channel you want blocked. Press ENTER to exit and enter any 4-digit "Parental Access Code" when prompted to do so. (You will be prompted to verify the number by entering it a second time.) 	<ul style="list-style-type: none"> Press the Up/Down keys to select Parental Ctl and press the Left/Right keys to view the PC Menu. Enter your access code. Make your changes (block more channels, reset the time period, etc.). Press ENTER to exit. You will be prompted to change your access code. Either enter a new 4-digit code or do nothing to retain the current code.
<p>REMEMBER YOUR CODE! TO RE-ACCESS PARENTAL CONTROL WHILE IT IS ACTIVATED, YOU MUST ENTER THIS NUMBER. Otherwise, simply allow the specified period of time to elapse.</p>		

NOTE:

- Do not unplug the TV in an attempt to deactivate the Parental Control. This only resets Parental Control.

USING CAPTIONS

Activating Captions (With CC Button)	Activating Captions/Text (From Setup Menu)
<ul style="list-style-type: none"> Press CC button on remote. Press CC repeatedly to toggle through the five choices: Off, Caption 1, Caption 2, Caption 3 And Caption 4. 	<ul style="list-style-type: none"> Press the Up/Down keys to select Caption/Text. Press Left/Right keys to toggle through the nine choices: Off, Caption 1, Caption 2, Caption 3, Caption 4, Text 1, Text 2, Text 3, or Text 4.

NOTE:

- At present, very few TV programs or video tapes offer text captioning for any option other than **CAPTION 1**. Therefore, **CAPTION 1** is the only recommended choice, unless you know that a specific program is providing captioning using one of the other selections.

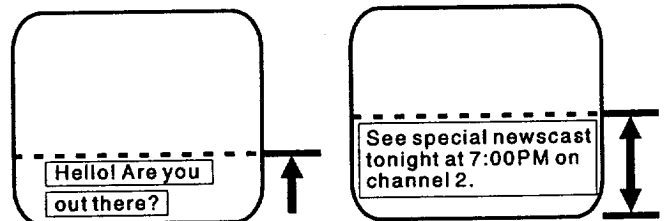

Typical Captions Display

Captions may be shown anywhere on the screen.

Typical Text Display

Fixed size text window fills lower half of screen.

AUDIO MENU

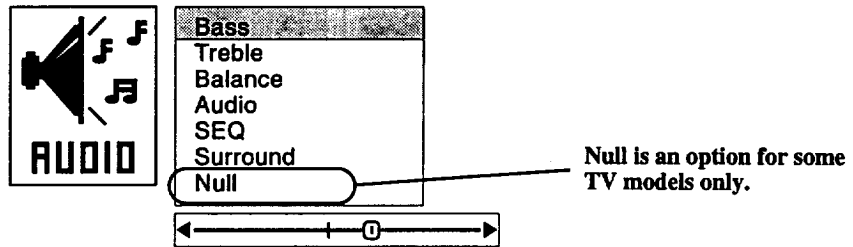

MENU OPERATION



Press MENU repeatedly until the AUDIO MENU is shown.



Press the Left/Right keys to adjust the selected option.



Press the Up/Down keys until the desired option is selected.



Press QUIT or wait a few seconds for the TV to return to normal operation.

Bass	Adjusts the BASS (low-frequency) level.
Treble	Adjusts the TREBLE (high-frequency) level.
Balance	Adjusts the balance of sound between the two speakers.
Audio (SAP is not an option for the video sources. Audio signals received from a video source are assumed to be monaural or stereo.)	<p>Allows you to select STEREO, MONO or 2ND AUDIO/SAP operation.</p> <p>STEREO: Directs the sound to the Left and Right speakers as supplied by the program. Stereo is the recommend choice: The TV switches automatically between the STEREO and MONO modes depending on the type of signal being received.</p> <p>MONO: Directs the same sound to both Left and Right speakers, even if the program being received is in stereo.</p> <p>2ND AUDIO/ SAP: Directs the sound for the Second Audio Program (second language) to both the Left and Right speakers. SAP sound is always monaural. If SAP is selected, you hear the SAP (usually a second language). When the SAP broadcast ends, the TV switches automatically (defaults) to the type of signal being received, STEREO or MONO. The TV switches back to 2ND AUDIO/SAP when the SAP broadcast resumes.</p>
SEQ (Spatial Equalization)	Produces a spacious and more tonal sound. SEQ is only available while a stereo signal is being received and processed by the TV.
Surround	Adjusts the level of Surround Sound provided to the optional surround sound speakers. Surround Sound is only available if a surround encoded stereo signal is being received and STEREO is either selected using the AUDIO option or selected by default.
Null	Used to Minimize front channel sound from coming through the surround speakers . To adjust the Null, while watching a Dolby Surround-encoded video tape, select Null and use the Left/Right keys to remove any dialogue that may be heard from the surround speakers.

NOTE:

- All adjustments on the Audio Menu are optional. You do not have to adjust these features in order to use your TV.

VIDEO MENU

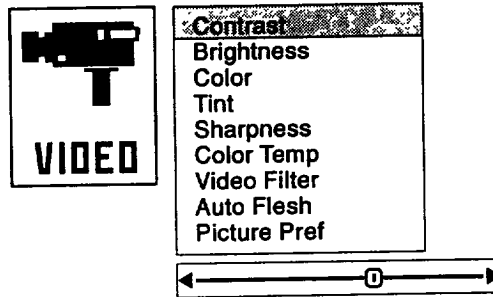

MENU OPERATION



Press MENU repeatedly until the VIDEO MENU is shown.



Press the Left/Right keys to adjust the selected option.

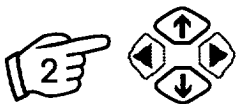

Press the Up/Down keys until the desired option is selected.



Press QUIT or wait a few seconds for the TV to return to normal operation.

Contrast	Adjusts the overall contrast and color level of the picture.
Brightness	Adjusts the brightness level of black areas in the picture.
Color	Adjusts the intensity of the colors in the picture.
Tint	Adjusts the color of the flesh tones to more Green or more Red.
Sharpness	Adjusts the definition of the object edges for best picture quality.
Color Temp (Temperature)	Changes the "color temperature" or picture white balance between cooler natural whites and warmer (red) colors.
Video Filter	Reduces video "noise" or interference in dark picture areas resulting in clearer overall pictures.
Auto Flesh	Automatically maintains natural skin tones under changing scene and video source conditions.
Picture Pref. (Preference)	Lets you decide if you want to use your own CUSTOM video settings, the factory PRESET video settings or the factory preset THEATER video settings. The THEATER settings are preset to provide optimum visual performance in low light "theater-like" conditions.

NOTES:

- All adjustments on the Video Menu are optional. It is not necessary to adjust these features in order to operate the TV.
- Any adjustments made to the Video Menu settings while Picture Pref. is in PRESET or THEATER mode will automatically store the current settings as the CUSTOM setting.

PIP MENU

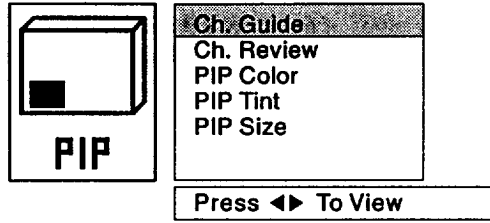

Selecting the PIP Menu does not “activate” PIP. However, a PIP inset will appear during menu operation to show the effect of any setting changes.

MENU OPERATION



Press MENU repeatedly until the PIP MENU is shown.



Press the Left/Right keys to adjust the selected option.



Press the Up/Down keys until the desired option is either high-lighted or selected.



Press QUIT or wait a few seconds for the TV to return to normal operation.

Ch. Guide	Provides a visual review of all channels in the channel scan memory for the currently selected ANT/CABLE source.
Ch. Review	Provides a visual review of the last three (3) channels tuned on the TV.
PIP Color	Adjusts the intensity of the colors in the PIP inset.
PIP Tint	Adjusts the color of the flesh tones in the PIP inset to more Green or more Red.
PIP Size	Adjusts the size of the PIP inset. Choose between small or large.

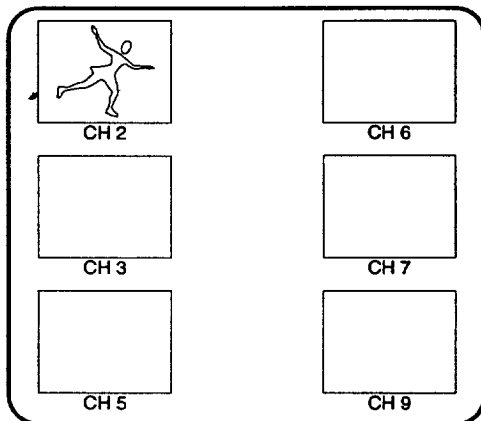

Ch. Guide Screen

Shows 3-second live displays of all channels saved in the channel scan sequence.

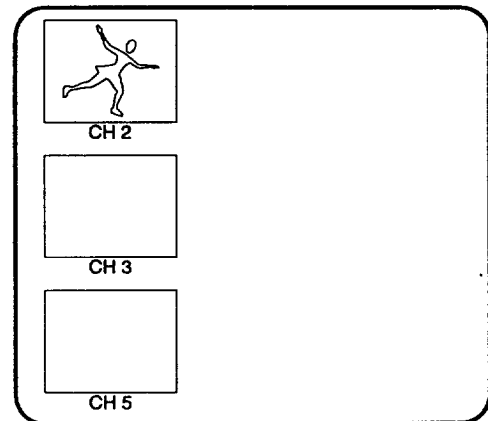

Ch. Review Screen

Shows 3-second live displays of the last 3 channels viewed on the TV.

REMOTE CONTROL Z-TRAK

INTRODUCTION

This multi-brand remote control operates the common features of most, but not all, models and brands of IR (infrared) controlled VCRs. Some functions of your particular equipment may not be controlled by this remote. In such cases, use the original remote control for your equipment.

BATTERY INSTALLATION

Batteries are provided, but must be installed before using the remote control. When it no longer functions normally, or if it loses memory, replace the batteries with two high-quality, alkaline, size AA batteries. Match plus with plus (+ with +), minus with minus (- with -) in the battery compartment.

Unless your equipment responds to the factory preset code, you will need to reprogram the remote after you replace the batteries.

NOTES:

- Do not place heavy objects on top of the remote control keys. Prolonged unintentional operation of the remote shortens battery life.
- Remove the batteries if the remote control will not be used for a month or more. **THE MANUFACTURER IS NOT RESPONSIBLE FOR DAMAGE CAUSED BY BATTERY LEAKAGE.**

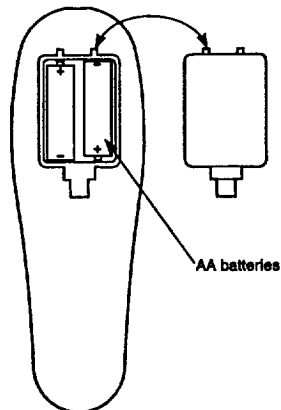

CHOOSING OPERATING MODE

To control your TV or VCR with this remote, you must first choose the mode of operation. Press the desired mode key for TV or VCR. Press TV to return to TV mode.

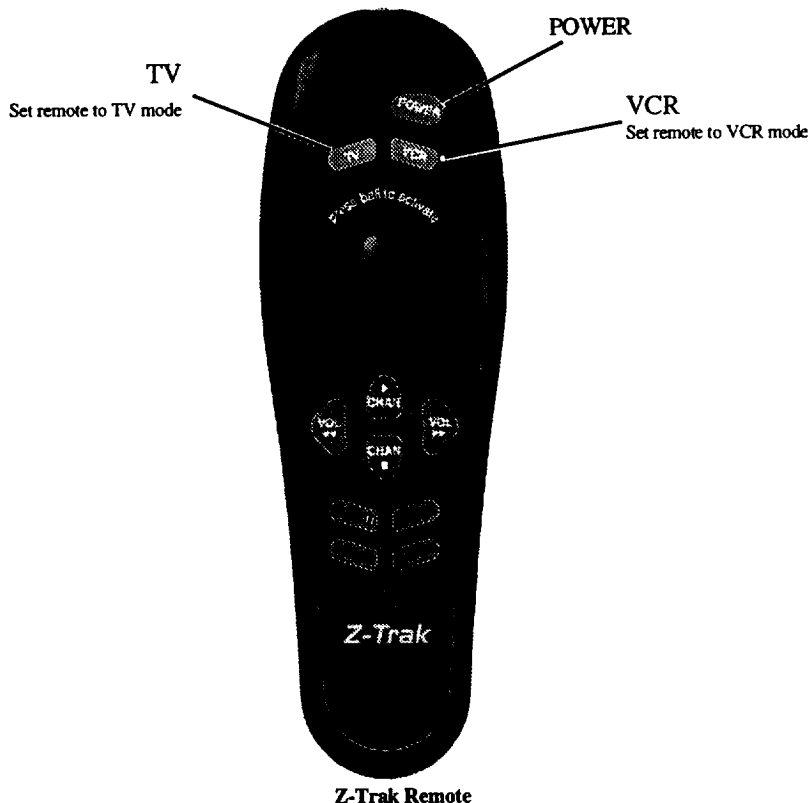

REMOTE CONTROL Z-TRAK

BASIC OPERATIONS

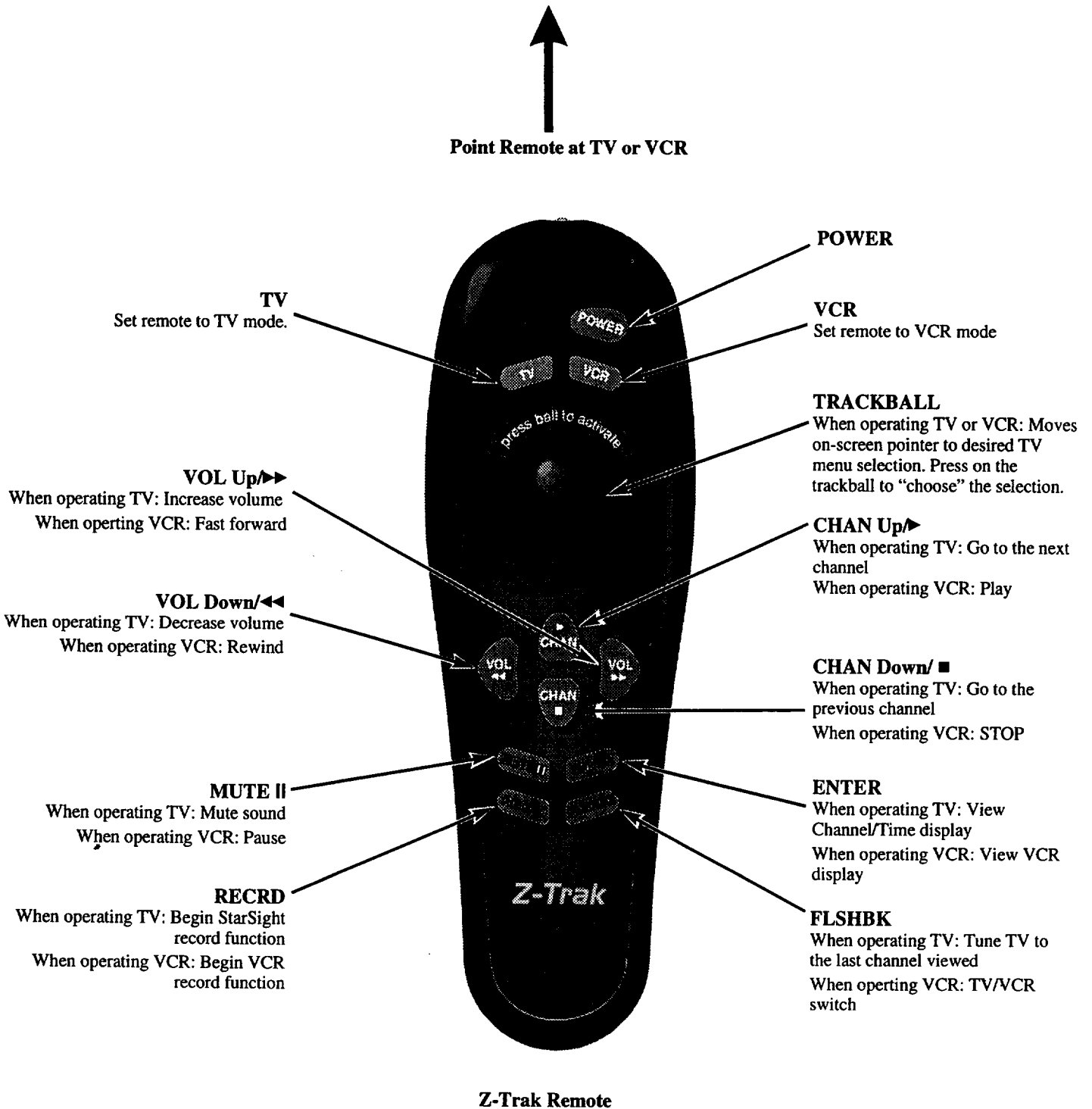

REMOTE CONTROL Z-TRAK

PROGRAMMING YOUR Z-TRAK REMOTE

Your Z-Trak remote is already programmed to work with most Zenith VCR's. If you have a non-Zenith VCR, or if your Zenith VCR does not respond to your Z-Trak remote, you will need to program your remote as follows:

1. Refer to the table of VCR Codes, in this section of the guide. Locate the 3-digit number which corresponds to your brand of VCR.
2. Make sure your TV is turned on.
3. While pointing the Z-Trak remote towards your Zenith TV, simultaneously hold the MUTE and ENTER keys until the TV displays a VCR "Setup" screen (about three seconds). The VCR key will also light upon entering the Programming mode.
4. Notice that the current VCR brand code (initially "201") is displayed on the TV screen. Roll the trackball up or down (or use CHAN Up/Down) to choose the 3-digit number of your VCR.
5. When the correct 3-digit number is displayed on the TV screen, use the POWER key to make sure that your VCR turns on and off properly. If it does not respond, refer to the VCR Codes table to select a different 3-digit number.
6. If your VCR turns on and off successfully, press the trackball (or ENTER) to save the current VCR brand code. The setup screen will disappear from the TV. Also, the VCR key will flash 3 times upon exiting the Programming mode. The remote will be in the VCR mode.

7. Now try other controls on your VCR, such as Play, Rewind, etc., to make sure that the correct VCR brand code number was selected. (If not, repeat steps 3 to 7.)
8. The MUTE key can be pressed at any time to cancel Programming mode. The original VCR brand code will remain unchanged.
NOTE: Only the VCR mode can be programmed.
9. The Z-Trak remote will exit Programming mode automatically after 60 seconds if no key press or trackball movement is detected.

AUTO FIND OPTION

If you have tried all 3-digit codes listed for your VCR manufacturer, and none of them operate your VCR, you will need to try "AutoFind" to see if a different code will operate your VCR:

1. Make sure your VCR is turned on.
2. Simultaneously hold the MUTE and ENTER keys until the VCR key lights up (about three seconds).

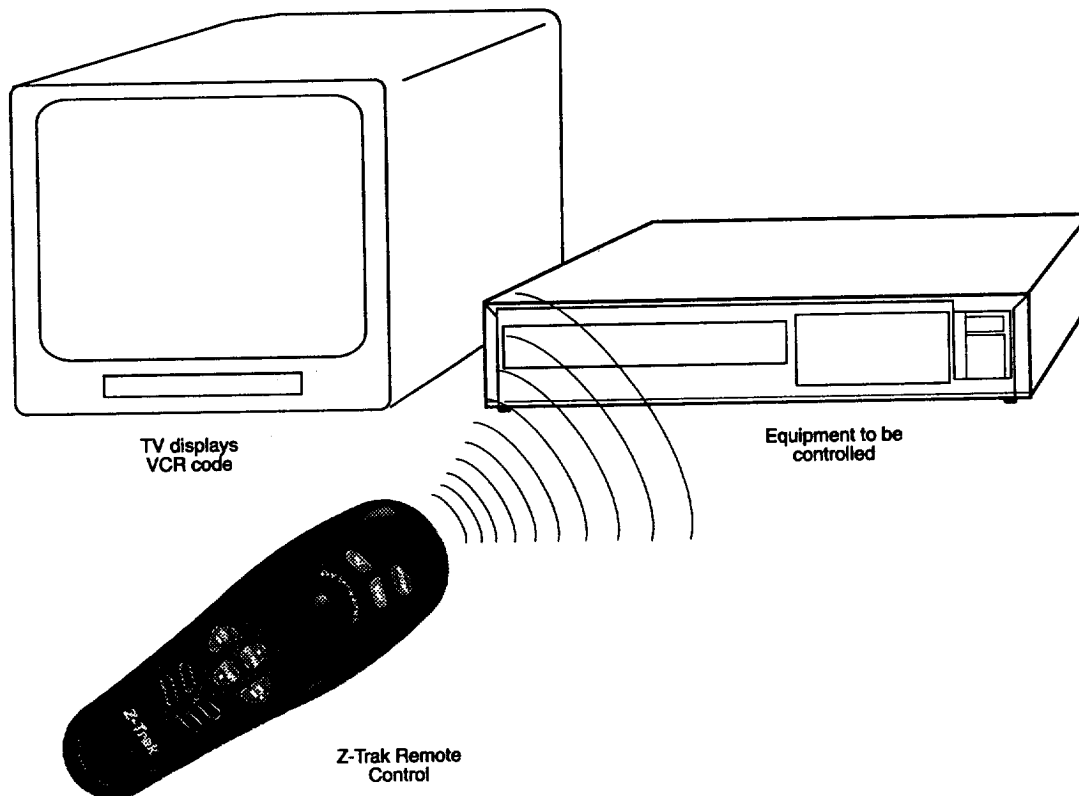

REMOTE CONTROL Z-TRAK

3. Point the Z-Trak remote towards your VCR. Press CHAN UP followed by POWER. If your VCR did not turn off, keep repeating CHAN UP followed by POWER until the VCR responds.
4. If your VCR turned off, press ENTER to save the code. The VCR button will flash three times after ENTER is pressed.
5. Now try other controls on your VCR, such as Play, Rewind, etc., to make sure that the correct VCR brand code number was selected. (If not, repeat steps 2 to 4.)
6. The MUTE key can be pressed at any time to cancel AutoFind mode. The original VCR brand code will remain unchanged.
7. The remote will exit AutoFind mode automatically after 60 seconds if no key press or trackball movement is detected.

NOTE:

- To view the code that was programmed, perform Steps 2 and 3 of "Programming Your Z-Trak Remote."

VCR CODES BY BRAND NAME

VCRS			
Admiral	208, 261	Montgomery Ward	208, 214, 216, 219, 231, 249
Adventura	231	Multi Tech	239
Aiwa	231	NEC	202, 218
Akai	223, 238, 241	Orion	250
Audio Dynamics	202, 218	Panasonic	214, 251, 259
Bell & Howell	206, 247	Pentax	215
Broksonic	221, 226, 250, 255	Philco	207, 214
Canon	214	Philips	207, 214, 227
Citizen	209	Pioneer	210, 215
Craig	212	Portland	246
Curtis Mathes	214, 259	Pro Scan	216, 260
Daewoo	244, 246, 248, 254	Quasar	214, 259
Daytron	236, 246	RCA	215, 216, 220, 227, 240, 242, 260
DBX	202, 218	Realistic	206, 208, 212, 214, 231
Emerson	203, 221, 223, 226, 233, 235, 243, 250	Samsung	220, 230
Fisher	211, 212, 213, 247	Sansui	239
Funai	231	Sanyo	206, 212, 247
General Electric	214, 216, 220	Scott	204, 205, 233, 243
Goldstar	209	Sears	206, 209, 211, 212, 215
Go Video	256, 262, 263	Sharp	208, 261
Hitachi	215, 257	Shintom	239
Instant Replay	214, 227	Signature 2000	208, 214, 216, 219, 231, 249
J.C. Penney	214, 215, 218, 227	Sony	217, 232, 237
JVC	202, 225, 258	Sylvania	207, 214, 227
Kenwood	202	Symphonic	231
Logik	239	Tashiko	209
LXI	209, 231	Tatung	202
Magnavox	207, 214, 231	Teac	202, 231
Marantz	207, 218	Teknika	234
Marta	209	Toshiba	205, 215
Memorex	206, 212, 214, 231	Vector Research	204, 218
Mitsubishi	204, 222, 252, 264	Yamaha	202, 218
		Zenith	201, 224, 225, 229, 237
		XR1000	239

CLEANING THE TRACKBALL

To keep the Z-Trak remote functioning properly, it is necessary to occasionally clean the TRACKBALL device. To do this:

1. Use a solution of mild dish washing detergent and water.
2. Moisten a clean soft cloth with the solution and lay the cloth flat on a table.
3. Turn the Z-Trak remote upside down and gently roll the TRACKBALL on the cloth.
4. Allow the remote to air-dry before using it again.

CAUTION:

- DO NOT USE ALCOHOL OR OTHER CLEANING FLUIDS TO CLEAN THE TRACKBALL AS THESE MAY DAMAGE THE REMOTE.

QUICK REFERENCE TO MENUS: Z-TRAK

AVAILABLE MENUS

Your TV is icon and menu operated. In other words, an icon is selected at the top of the TV screen and a menu of adjustment options appears.

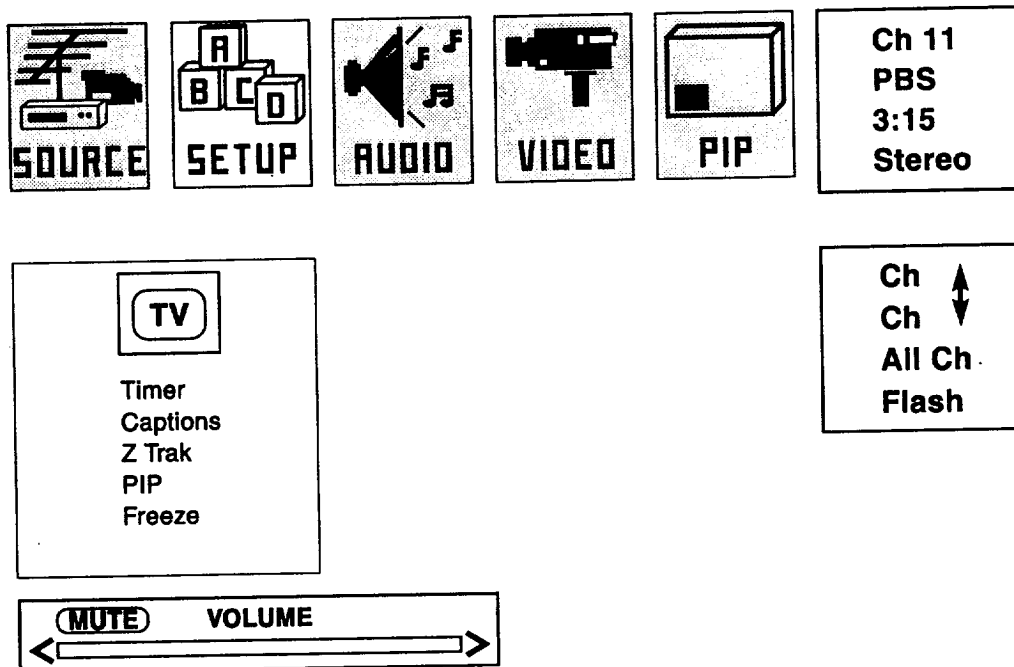

BASIC MENU OPERATION

1. Make sure that your Z-Trak remote is in the TV mode (rather than VCR mode), by pressing the TV button on the top.
2. Press the trackball. A small square, known as the *pointer*, appears in the middle of the screen. It should be *blue*, indicating TV mode. If you have StarSight, the pointer may be *red*, indicating StarSight mode. The next step tells you how to switch modes.
3. The pointer is moved by rolling the trackball up, down, left, and right. Move the pointer to the left edge of the screen. A column of TV options appears. The icon at the top indicates which mode is active — TV or StarSight (if connected). A TV icon represents TV mode; a circle with a star represents StarSight mode. You can switch between the two modes by locating the pointer on the icon and pressing the trackball. The icon switches and the pointer changes color.

Set the mode to TV (a blue pointer).

The various menus are not all visible on the screen simultaneously. Each menu appears when you move the pointer on top of it.

NOTE: Whenever the text reads "point to the option", it means "position the pointer on the option".

4. To make the pointer disappear, move it to the center of the screen and press the trackball.

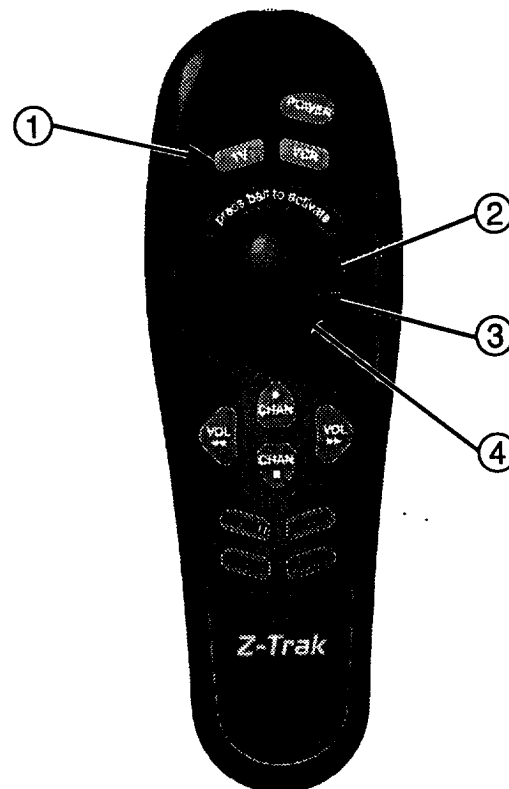

QUICK REFERENCE TO MENUS: Z-TRAK

CHANNEL ICONS

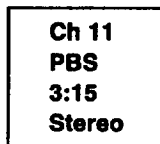

The Channel/Time display accompanies the Channel Icons Menu.

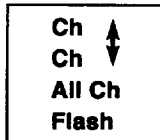

Chan ↑ and ↓	Channel up or down; equivalent to CHAN Up or Down on the remote. Point to the arrow and press.
All Ch	Gives you a complete listing of all channels on the screen. Channels currently stored in memory (via Auto Program) are shown in color. However, you can tune to any channel on the list. Point and press on a channel; the program on that channel is shown in the PIP, along with the channel label. To tune to that channel, press on it again.
Flash	Tunes the TV to the last channel viewed. The FLSHBK button on the Z-Trak remote performs the same function.

VOLUME CONTROL



1 Move the pointer to the bottom of the screen to view the Volume Control.



2 Point to the desired volume level on the slider bar, and press the trackball. The volume level automatically jumps to the new value. Or, press on the arrows to gradually raise or lower the volume.



3 Point and press on MUTE to turn the sound off completely.

You may also control volume and mute using the VOL Up/Down and MUTE buttons on the Z-Trak remote.

TV OPTIONS MENU

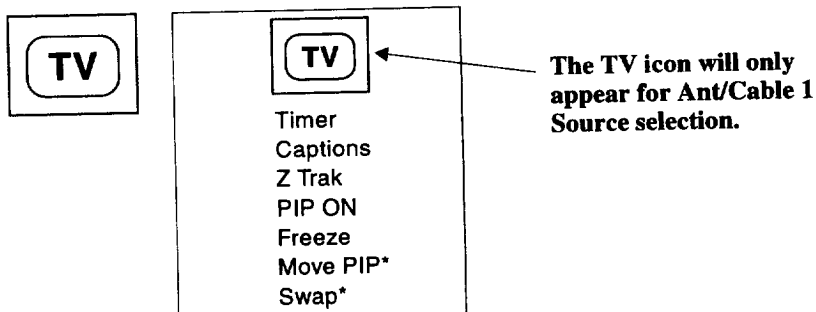

*Not always displayed.
See table below

MENU OPERATION



Move the pointer to the left of the screen to view the TV Options Menu.



Press the trackball to select the option. See the table below.



Point to the desired option. (Its status is shown at the bottom of the screen.)



Move pointer off the menu to remove it from view.

Timer	The sleep timer allows you to program the TV to automatically turn itself off after a period from 15 minutes up to 4 hours. To activate this feature and change the interval, press the trackball while pointing at Timer.
Captions	By pressing on this option, you can select Caption 1, Caption 2, Caption 3, Caption 4 or OFF.
Z-Trak	This determines how fast the pointer moves as you roll the trackball. By pressing on this option, you can set this response speed to Slow, Medium, or Fast, according to your preference.
PIP ON (or OFF)	This turns the PIP (Picture-In-Picture) on or off. When you first turn the PIP on, the options menu disappears and the pointer moves into the PIP. You can then move the PIP around the screen, using the trackball. Pressing the trackball then locks the PIP in place and removes the pointer.
Freeze	Pressing on this option “freezes” the action of the picture in the PIP inset. See PIP Operation section for details.
Move PIP	This option only appears when the PIP is on. Pressing on it causes the options list to disappear, and the pointer appears in the PIP. You can then move the PIP around the screen with the trackball. Pressing again locks the PIP in its new location and returns the TV to normal viewing.
Swap	This option only appears when the PIP is on and the PIP source is different from the main source. This option “swaps” the main picture with the picture in the PIP inset.

SOURCE MENU

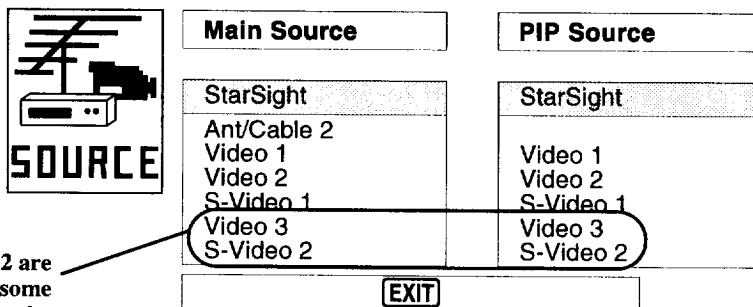

Video 3 and S-Video 2 are source options for some TV models only.

A PIP inset appears while the Source icon is selected to show the effect of choosing a PIP source.

If the PIP Source is changed, the PIP inset will remain on the screen after you exit from menu operations.

MENU OPERATION



Move the pointer to the top left of the screen and point to the SOURCE icon. Press the trackball.



Point to "EXIT" and press the trackball to remove the menu from view.



Point to the desired Main or PIP source. Press the trackball. Or, press repeatedly on **Main Source** or **PIP Source** to toggle through your source options

SOURCE SELECTION

ANT/CABLE 1 or 2	Routes the antenna or cable-TV source to the TV for viewing. You see program material from whichever signal source is connected to the ANT/CABLE 1 or 2 jack. (If the signal is from a VCR or a cable box, tune the TV to either channel 3 or 4.)
VIDEO 1, 2 or 3	Routes the audio and video from an A/V source (such as a VCR or a video disc player) to the TV for viewing. The source must be connected to the corresponding VIDEO 1, 2 or 3 IN jacks.
S-VIDEO 1 or 2	Routes the audio and video from an auxiliary Super-VHS video source (such as a VCR or a video disc player) to the TV for viewing. The source must be connected to the corresponding S-VIDEO 1 or 2 IN jacks.

Refer to the "Standard Connections for Your TV" section to make the proper equipment connections to the TV. For information about PIP sources, refer to the "PIP Operation" section.

SOURCE IDENTIFICATION

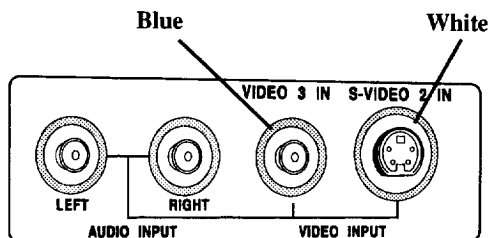

Auxiliary A/V Jacks (Some TV Models)

NOTE:

- The color of the Channel/Time display corresponds to the color rings around the connectors of the jack panels. For example, the Channel/Time display will be Red if you are watching a program on Ant/Cable 1 source.

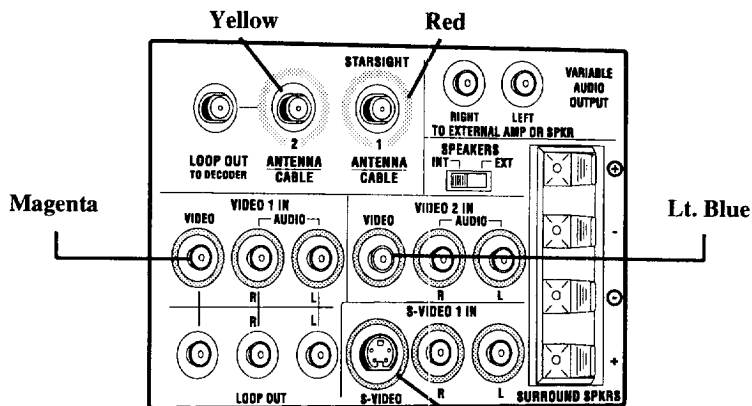

Connection Center on Back of TV

SETUP MENU

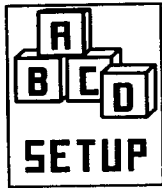

Auto Program
Ch. Add/Del
Ch. Labels
Source ID
Clock Set
Timer Setup
Parental Ctl
Caption/Text
Background
StarSight

Press To Program

Source ID
Clock Set
Timer Setup
Parental Ctl
Caption/Text
Background

Press To Label Sources

While Video or Super-Video Source is Chosen

MENU OPERATION



Move the pointer to the top left of the screen and point to the SETUP icon. Press the trackball.



Press on the option again to access it.



Point and press on the desired option to highlight it.



Point and press on EXIT or move the pointer off the menu and press the trackball to remove the menu from view.

Auto Program	Finds all active channels and stores them in the TV's memory for use by CHANNEL up/down. Follow the on-screen directions. Auto Program runs on the currently selected Ant/Cable source.
Ch. (Channel) Add/Del	Edits the channels found by Auto Program to create your own personal list of favorite channels. See the information following this chart for more details.
Ch. (Channel) Labels	Assigns a network/station label, name or call letters to specified channels. For example, if you choose the label "ABC" for channel 9, then "ABC" will appear in the Channel/Time display whenever channel 9 is selected. See the information following this chart for more details.
Source ID	Assigns a descriptive "name" to the input sources. For example, the Video 1 source may be named VCR. "VCR" will now appear in the Source Menu as a reminder that your VCR is connected to the Video 1 input jacks.
Clock Set	Sets the clock in the TV to the correct time. Point and press on the option to highlight it. In the status bar at the bottom, point and press on either the hours or minutes to adjust them. Point and press on AM or PM to toggle them. Move pointer away from menu to remove it from view.
Timer Setup	Sets the TV's SLEEP TIMER and ON/OFF TIMER features. See the information following this chart for more details.
Parental Ctl. (Control)	Use this feature to block viewing of any undesirable channels or an entire input video source. See the information following this chart for more details.
Caption/Text	Displays closed captioning or informational text when available on the selected channel. Options are: OFF, CAPTION 1, CAPTION 2, CAPTION 3, CAPTION 4, TEXT 1, TEXT 2, TEXT 3, or TEXT 4. See the information following this chart for more details.
Background	Adds or removes a solid-color background behind the on-screen menus. Highlight and press on the option, and then press to toggle the background on and off.
StarSight (Ant/Cable 1 Source selection only)	Begins the StarSight setup procedure. Refer to the StarSight section of this guide for details.

continued on next page

SETUP MENU

USING CHANNEL ADD/DEL

Add Channels to Scan	Delete Channels from Scan
<ul style="list-style-type: none"> Select Ch. Add/Del. Point to the desired channel. Press trackball until channel status shows Added. 	<ul style="list-style-type: none"> Select Ch. Add/Delete. Point to the desired channel. Press trackball until channel status shows Deleted.
Press on EXIT to tune to the channel pointed to by the highlight.	

NOTE:

- Ch. Add/Del can only be used with ANT/CABLE 1 or 2 Source selection.
- The Audio of deleted channels is muted.

Selector Highlight

Available Channels

Live view of selected channel.

Channel Status

Press here to access additional numbers if present.

Available channels are:

Broadcast Band — VHF 2 to 13, UHF 14 to 83

Cable-TV Band — 1 to 139

USING CHANNEL LABELS

Assign Labels	Remove/Prevent Labels
<ul style="list-style-type: none"> Select Ch. Labels. Select a channel by pointing and pressing Ch ↑ or ↓. Point and press on the desired label. Press on EXIT to return to normal viewing. 	<ul style="list-style-type: none"> Select Ch. Labels. Select a channel by pointing and pressing Ch ↑ or ↓. Point and press on the four dashes or NONE. Press on EXIT to return to normal viewing.

NOTE:

- Ch. Labels can only be used with ANT/CABLE 1 or 2 Source selection.
- Selecting the four dashes (----) specifies no channel label. Or, selecting NONE blocks the station or network labels that are transmitted by some television stations.

Selector Highlight

Available Labels

Live view of selected channel.

Current Channel

Selected Label

Channel Selector

Point and press on this box for more labels.

USING SOURCE ID

Assign Names To Your Sources
<ul style="list-style-type: none"> Select Source ID. Point to the desired "Source/Label" line and press to highlight it. Press repeatedly to scroll through the available labels. Press on EXIT to return to normal viewing.

VIDEO GAMES AND OTHER FIXED PATTERN DISPLAY CAUTION

If you use your TV for video games or other fixed displays, avoid setting the BRIGHTNESS control for an excessively bright picture. A bright, fixed pattern, if used for long periods of time, can result in a permanent imprint on the TV picture tube. You can reduce this possibility by alternating the use of the fixed pattern display with normal TV picture viewing, by turning down the CONTRAST control for sustained fixed pattern use, and by turning off the fixed pattern display when not in use.

Live view of selected Source.

Source

Label

Optional names for ANT/CABLE 1 or 2 Sources are:
 —, Disabled, Antenna, Cable, Cable Box, Satellite, VCR, StarSight (Ant/ Cable 1 only).

Optional names for VIDEO Sources are:
 —, Disabled, VCR, Camcorder, Video Game, Laser Disc, Audio Only, VCR2, Satellite. (Some models only.)

NOTE:

- Disabling a Source prevents it from appearing in the Source Menu.

SETUP MENU

TIMER SETUP: Sleep Timer

The Sleep Timer programs the TV to automatically turn itself off after a period from 15 minutes up to 4 hours.

From Setup Menu	Direct Access
<ul style="list-style-type: none"> • Make sure the TV's clock is set. • Select Timer Setup to view the Timer Menu. • Press on Sleep Timer repeatedly to set the period of time the TV will remain on. 	<ul style="list-style-type: none"> • Move pointer to left of screen to view the TV Option Menu. • Point and press on Timer repeatedly to set the period of time the TV will remain on. • Move pointer away from menu to remove it from view.
<ul style="list-style-type: none"> • One minute before the TV turns off, the GOOD NIGHT display appears on the screen. At this time you have a choice of the following two actions. • Do nothing. The GOOD NIGHT display remains on the screen. The TV will turn off in one minute. • Delay the turn-off by resetting the timer with a new time period. 	

Timer Menu

Sleep Timer
 On Time
 Off Time
 On/Off Timer

0:15

Timer Set to Turn TV OFF in 15 Minutes

Sleep Timer
 Good Night 0:58

"Good Night" Display Appears 60 Seconds Before Shut-Off

NOTE:

- To cancel the Sleep Timer, turn off the TV or return to the Timer feature and set it to OFF.
- As the Good Night display counts down the final 60 seconds, the audio and video of the TV also "dim" for a soft, discreet turn-off.

ON/OFF TIMER

The On/Off Timer programs the TV to automatically turn itself on at a specific time, then turn itself off at another time.

Set On/Off Timer
<ul style="list-style-type: none"> • Make sure clock is set to Timer Setup. • Select On Time. In the Status bar at the bottom, point and press on the hours and minutes to adjust them to the time you want the TV to turn itself ON. Point and press on AM (or PM) to toggle them. • Select Off Time. In the Status bar at the bottom, point and press on the hours and minutes to adjust them to the time you want the TV to turn itself OFF. Point and press on AM (or PM) to toggle them. Or, press on the arrows to move the time forward or backward. • Select ON/OFF Timer and press on it to turn the timer ON (or OFF).

Timer Menu

Sleep Timer
 On Time
 Off Time
 On/Off Timer

Point and press on these to adjust

11:00 AM

On/Off Timer Set to Turn TV ON at 11:00 am

NOTE:

- A time must be set for either On Time or Off Time in order to turn the timer ON.

SETUP MENU

USING PARENTAL CONTROL (PC)

Enter Parental Access Code: - - - -

<0><1><2><3><4><5><6><7><8><9>

Parental Control Menu

Block Hours
Block Source
Block Channels

OFF

Point and press on these digits to enter code.

Period of time PC will be active.
Blocks entire source.
Blocks individual channels for Ant/Cable 1 or 2 sources.

Live view of selected channel.
Channel
Status
EXIT

Block Entire Source	Block Individual Channels	Re-enter PC While it is Activated
<ul style="list-style-type: none"> Select Parental Ctl. Select Block Hours and press on the arrow to set the length of time PC will be active: OFF, 12, 24, 48, or 72 hours. Set Block Source. Move the pointer to the status bar at the bottom and press on "unblocked" to change it to "blocked." To block other sources, move the pointer to the left side of the status bar and press to select another source. Move the pointer back to the right side and press to show "blocked." Point and press on Exit and enter any 4-number access code by pressing on the individual numbers. You will be asked to verify the code by entering it again. 	<ul style="list-style-type: none"> Select Parental Ctl. Select Block Hours and press on the arrow to set the length of time PC will be active: OFF, 12, 24, 48, or 72 hours. DO NOTHING WITH BLOCK SOURCE. Select Block Channels. For each channel to be blocked, move the pointer to the number and press the trackball twice. Point and press on Exit twice and enter a 4-number access code by pressing on the individual numbers. 	<ul style="list-style-type: none"> Select Parental Ctl. Enter your access code when prompted to do so. Make your changes (block more channels, reset the time period, etc.) Point and press on Exit. You will be prompted to "change code if desired." Either enter a new 4-number code or do nothing to retain the current code.
<p>REMEMBER YOUR ACCESS CODE! TO RE-ACCESS PARENTAL CONTROL WHILE IT IS ACTIVATED, YOU MUST ENTER THIS NUMBER. Otherwise, simply allow the specified period of time to elapse.</p>		

NOTE:

- Do not unplug the TV in an attempt to deactivate the Parental Control. This only resets Parental Control.

USING CAPTIONS

Activating Captions
<ul style="list-style-type: none"> Highlight and press Caption/Text. Press the trackball repeatedly to toggle through the nine choices: Off, Caption 1, Caption 2, Caption 3, Caption 4, Text 1, Text 2, Text 3, or Text 4.

NOTE:

- At present, very few TV programs or video tapes offer text captioning for any option other than **CAPTION 1**. Therefore, **CAPTION 1** is the only recommended choice, unless you know that a specific program is providing captioning using one of the other selections.

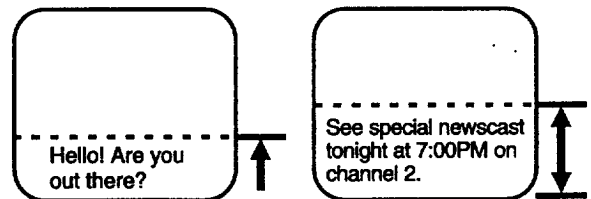

Typical Captions Display
Captions may be shown anywhere on the screen.

Typical Text Display
Fixed size text window fills lower half of screen.

AUDIO MENU

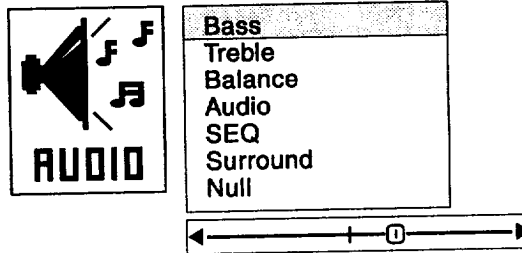

MENU OPERATION



Move the pointer to the top left of the screen and point to the AUDIO icon. Press the trackball.



Press on the option or on the slider bar to adjust the option.



Point and press on the desired option to highlight it.



Move the pointer off the menu and press the trackball to remove the menu from view.

Bass	Adjusts the BASS (low-frequency) level. Point and press on the arrows or slider bar.
Treble	Adjusts the TREBLE (high-frequency) level. Point and press on the arrows or slider bar.
Balance	Adjusts the balance of sound between the two speakers. Point and press on the arrows or slider bar.
Audio (SAP is not an option for the video sources. Audio signals received from a video source are assumed to be monaural or stereo.)	Allows you to select STEREO, MONO or 2ND AUDIO/SAP operation. After highlighting the option, press to toggle through the choices: STEREO: Directs the sound to the Left and Right speakers as supplied by the program. Stereo is the recommended choice: The TV switches automatically between the STEREO and MONO modes depending on the type of signal being received. MONO: Directs the same sound to both Left and Right speakers, even if the program being received is in stereo. 2ND AUDIO/SAP: Directs the sound for the Second Audio Program (second language) to both the Left and Right speakers. SAP sound is always monaural. If SAP is selected, you hear the SAP (usually a second language). When the SAP broadcast ends, the TV switches automatically (defaults) to the type of signal being received, STEREO or MONO. The TV switches back to 2ND AUDIO/SAP when the SAP broadcast resumes.
SEQ (Spatial Equalization)	Produces a spacious and more tonal sound. SEQ is only available while a stereo signal is being received and processed by the TV.
Surround	Adjusts the level of Surround Sound provided to the optional surround sound speakers. Surround Sound is only available if a surround encoded stereo signal is being received and STEREO is either selected using the AUDIO option or selected by default.
Null (Some Models Only)	Used to Minimize front channel sound from coming through the surround speakers. To adjust the Null, while watching a Dolby Surround-encoded video tape, select Null and use the Left/Right keys to remove any dialogue that may be heard from the surround speakers.

NOTE:

- All adjustments on the AUDIO MENU are optional. You do not have to adjust these features in order to use your TV.

VIDEO MENU

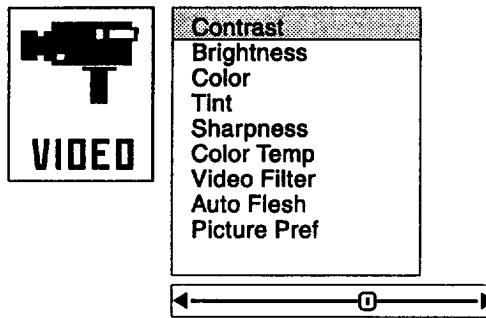

MENU OPERATION



Move the pointer to the top left of the screen and point to the VIDEO icon. Press the trackball.



Press on the option or on the slider bar to adjust the option.



Point and press on the desired option to highlight it.



Move the pointer off the menu and press the trackball to remove the menu from view.

Contrast	Adjusts the overall contrast and color level of the picture.
Brightness	Adjusts the brightness level of black areas in the picture.
Color	Adjusts the intensity of the colors in the picture.
Tint	Adjusts the color of the flesh tones to more Green or more Red.
Sharpness	Adjusts the clarity of the edges around objects for the clearest picture quality.
Color Temp (Temperature)	Changes the "color temperature" or picture white balance between cooler natural whites and warmer (red) colors.
Video Filter	Reduces video "noise" or interference in dark picture areas resulting in clearer overall pictures.
Auto Flesh	Automatically maintains natural skin tones under changing scene and video source conditions.
Picture Pref. (Preference)	Lets you decide if you want to use your own CUSTOM video settings, the factory PRESET video settings or the factory preset THEATER video settings. The THEATER settings are preset to provide optimum visual performance in low light "theater-like" conditions

NOTES:

- All adjustments on the Video Menu are optional. It is not necessary to adjust these features in order to operate the TV.
- Any adjustments made to the Video Menu settings while Picture Pref. is in PRESET or THEATER mode will automatically store the current settings as the CUSTOM setting.

PIP MENU

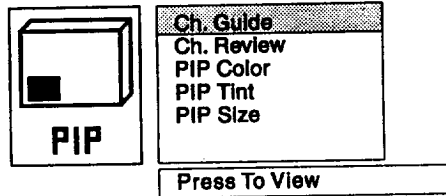

Selecting the PIP Menu does not “activate” PIP. However, a PIP inset will appear during menu operation to show the effect of any setting changes.

MENU OPERATION



Move the pointer to the top left of the screen and point to the PIP icon. Press the trackball.



Press on the option or on the slider bar to adjust the option.



Point and press the desired option to highlight it.



Move the pointer off the menu and press the trackball to remove the menu from view.

Ch. Guide	Provides a visual review of all channels in the channel scan memory for the currently selected ANT/CABLE source. Press on a PIP inset to tune to the channel shown in the inset.
Ch. Review	Provides a visual review of the last three (3) channels tuned on the TV. Press on a PIP inset to tune to the channel shown in the inset.
PIP Color	Adjusts the intensity of the colors in the PIP inset. Point and press on the arrows or slider bar.
PIP Tint	Adjusts the color of the flesh tones in the PIP inset to more Green or more Red. Point and press on the arrows or slider bar.
PIP Size	Adjusts the size of the PIP inset. Choose between small or large.

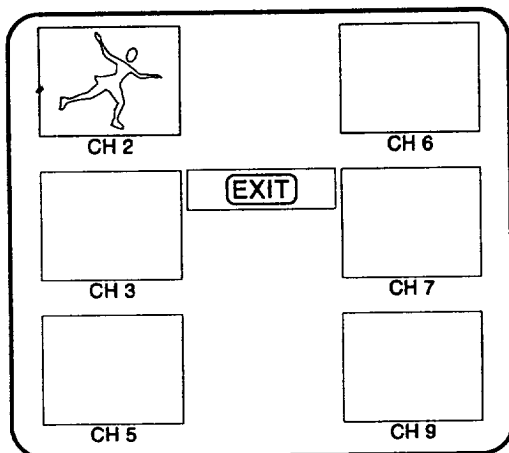

Ch. Guide Screen

Shows 3-second live displays of all channels saved in the channel scan sequence.

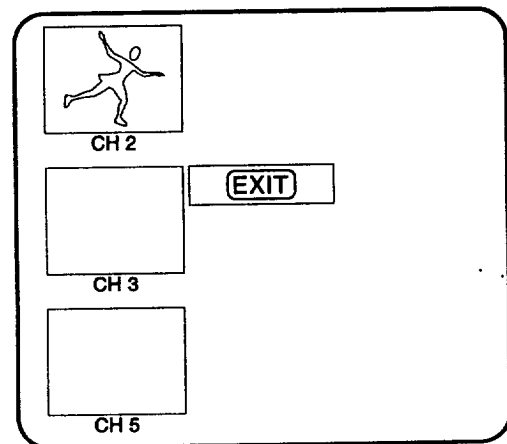

Ch. Review Screen

Shows 3-second live displays of the last 3 channels viewed on the TV.

MAINTENANCE AND TROUBLESHOOTING

CARING FOR YOUR TV

Your TV will look better, have a longer life and perform better if you care for it properly.



First check to see that the TV is off. For added safety, unplug the TV from the power outlet.

NOTE: If you unplug your TV, you will have to reset the clock to the current time.

Cabinet Care

Non-Wood Cabinet or Cabinet Components Moisten a soft cloth with a mild soap solution or Ivory dishwashing detergent. Wipe the surface with a damp cloth. Then rinse the cloth in clean water and wipe the surface again. Allow the TV to air-dry before turning it on.

Wood Cabinets or Cabinet Components Use any good furniture cleaner and polish. Regular care will help preserve the finish.

Picture Glass Cleaning

The picture tube face attracts dust particles and should be cleaned regularly. To clean the face, spray a small amount of glass cleaner on a cleaning cloth and wipe the picture tube glass face until clean. Repeat if necessary.

To delay new dust accumulation, wet a soft cloth in lukewarm water in which a little fabric softener or Ivory dishwashing detergent has been mixed. Wring the cloth almost dry. Wipe the glass face. Make sure no drops of moisture are squeezed onto the glass. Do not wipe the glass dry. Allow the glass to air-dry before you turn the TV on again.

EXTENDED ABSENCE

Before an extended absence (such as a vacation) you may want to unplug the power cord from the electrical wall outlet. This will protect the TV from possible damage from lightning or power line surges. If you have an outdoor antenna, you may also want to disconnect the antenna lead-in wires on the back of the TV.

NOTE: If you unplug your TV, you will have to reset the clock to the current time.

TV PICTURE INTERFERENCE

Your TV picture may be affected by interference caused by one or a number of factors. These include:

Speckled or Streaked Picture Can be caused by nearby automobile ignition, electrical appliances, etc. This is most noticeable in weak signal areas.

Snow in Picture Caused by insufficient signal. Usually caused by the TV being located too far from the TV station or by an improper antenna installation.

Ghosts or Reflections Caused by signals being reflected from surrounding buildings, water tanks, or other high structures.

Radio Signal Police, amateur or CB radio transmitters may cause interference.

These interference problems can often be corrected through the use of a better antenna, signal amplifiers, or various filter devices. See your TV dealer for additional information, and available TV accessories.

MAINTENANCE AND TROUBLESHOOTING

BEFORE CALLING FOR SERVICE

Check these items and see if you can correct the trouble by changing the adjustment of a control or the setting of a switch. By making these simple checks before calling for service, you may save time and money.

Problem	Try This
Picture OK. Poor sound.	Re-orient antenna. Try another channel — possible station trouble. Adjust AUDIO MENU options. Check for local interference. Is antenna/cable connection loose?
Sound OK. Poor picture.	Re-orient antenna. Try another channel — possible station trouble. Adjust VIDEO MENU options. Trouble with cable-TV system? Is antenna/cable connection loose?
No picture or sound.	Is TV on? Is there power in wall outlet? Is TV plugged in? Is antenna hooked up? Is cable hooked up? Trouble with cable-TV system? Check auxiliary audio/video equipment. Check channel selection. Is the channel blocked by PARENTAL CONTROL?
Picture blurred or distorted. Ghost in picture.	Check antenna or cable hook up for broken wires. Try another channel — possible station trouble. Check for local interference.
No color, or poor color.	Is it a color program? Check antenna or cable hook up for broken wires. Adjust VIDEO MENU options.
No sound.	VOLUME (VOL) setting may be too low. Check MUTE button operation on remote control. Is Speaker EXT/INT switch set to EXT?
Cannot select certain channels.	Channels may be skipped in CH. ADD/DEL option of SETUP MENU. Use AUTO PROGRAM a second time.
No closed captions	Are captions available? Is CAPTION 1, CAPTION 2, CAPTION 3, OR CAPTION 4 selected using the CAPTIONS option on the SETUP MENU?
Black or blue box covers half of screen.	Is text information available? Is TEXT 1, TEXT 2, TEXT 3 or TEXT 4 selected in the CAPTIONS option of the SETUP MENU.
No picture or sound when VIDEO 1 or VIDEO 2 source is selected.	Is audio/video source hooked up properly? Are all wires connected to VIDEO 1 IN or VIDEO 2 IN jacks on connection center?
No stereo sound or weak stereo sound when using a stereo VCR.	Check AUDIO mode. Was stereo sound present before selecting VIDEO 1 or VIDEO 2 source?
PIP inset frame is black or lacks contrast when selecting VIDEO 1 for PIP inset.	Adjust PIP COLOR AND CONTRAST settings in PIP MENU. Are all wires connected to VIDEO 1 IN jacks on connection center?
PIP inset frame is "snowy" when using ANT/CABLE 1 or 2 for PIP and VIDEO 1 for main picture.	Is TV/VCR switch on the VCR in the TV position?
No picture when using VIDEO 1 for PIP inset source and ANT/CABLE 1 or 2 for main picture.	Is TV/VCR switch on the VCR in the TV position?
Remote control does not work.	Are batteries okay? Is TV turned ON? Is remote in TV mode?

Always request that your technician use only genuine Zenith exact replacement parts for continued Quality and Safety performance. Keep your Zenith ALL Zenith.

NOTES:

- If your TV fails to respond to the PICTURE PREF. selection, or to any other menu selection, you must reset the TV. Simply disconnect the AC power cord from the power outlet. Wait a few minutes, then plug the TV back into the power outlet. You will have to reset the clock to the current time.
- Unplugging the TV does not deactivate the Parental Control.

REPLACEMENT PRODUCT REGISTRATION CARD

You could win a full refund on your new Zenith product.

Look for the Product Registration Card on your new video product.

Each month a drawing is held by Zenith from the completed Product Registration Cards received during the preceding month. Zenith will reimburse the winner for the full purchase price of the product purchased.

In order to participate, simply complete and return the Product Registration Card at once, even if you choose not to complete the information and interests portion of the questionnaire.

Product Card lost or misplaced?

The Product Registration Card furnished with your video product is pre-printed with its Model and Serial numbers. Please fill out the card and mail it at your earliest convenience. It is imperative that Zenith know how to reach you promptly if we discover a safety problem that would affect you. If the original card has been lost or misplaced, you may use the replacement card provided below. Either card will qualify you for the free drawing, but you are limited to only one entry in the drawing. Complete the card, place it in an envelope and mail it to:

Zenith Electronics Corporation
P. O. Box 173257
Denver, CO 80217-3257

Use the replacement Product Registration Card only if the original card has been misplaced or lost.

The odds of winning the free drawing described above, depend on the number of participants. Free drawing offer is void in Canada and other places where restricted or prohibited by law. Offer is void for Hotel/Motel and Institutional models. Rental models are not eligible.

PHOTOCOPY AND CUT ALONG DASHED LINE

Zenith Product Registration Card		H5Z01-01								
① Please Print Clearly or Type		② Area Code Telephone								
1. <input type="checkbox"/> Mr. 2. <input type="checkbox"/> Mrs. 3. <input type="checkbox"/> Ms. 4. <input type="checkbox"/> Miss		<input type="text"/> <input type="text"/> <input type="text"/> - <input type="text"/> <input type="text"/> <input type="text"/>								
First Name Initial Last Name										
<input type="text"/>										
Street		Apt. No.								
<input type="text"/>		<input type="text"/>								
City										
<input type="text"/>										
State	Zip Code	③ Date of Purchase								
<input type="text"/>	<input type="text"/> - <input type="text"/>	Mo. Day Yr.								
		<input type="text"/> <input type="text"/> <input type="text"/>								
MODEL NUMBER	<input type="text"/>									
Copy Numbers Here From Label on Set										
SERIAL NUMBER	<input type="text"/>									

← Please record the model number and serial number from the sticker on the back of your set.

BROKEN OR LOST REMOTE CONTROL?

Makes a great spare remote control too!



For an **Exact Replacement Remote Control** for your new Zenith Television, see your local Zenith Dealer or order direct by calling 1-800-255-6790. To assure the correct remote for your new Zenith, please have your television's model number ready!

ONLY \$39.95

OTHER FINE ACCESSORIES FOR YOUR VCR.

Wireless Speaker System:

- Wireless speakers receive sound from TV, VCR, or Stereo **through walls, floors, or outside.**
- Creates an instant home entertainment center!
- Speakers are easy to move--"no cord clutter." An attractive addition to any room.
- Works up to 150 feet! **Indoors and outdoors.**

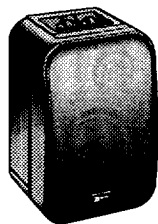

ZEN800
WIRELESS
SPEAKER SYSTEM
ONLY \$249.95

Wireless Headphone System:

- Wireless Headphones receive sound from TV, VCR or Stereo **through walls, floors or outside.**
- Allows freedom of activity while relaxing or working around your home.
- Listen to your stereo while others watch TV in the same room.
- Works up to 150 feet! **Indoors and outdoors.**



ZEN801
WIRELESS
HEADPHONE SYSTEM
ONLY \$119.95

Wireless Infrared Headphone System:

- Enjoy your favorite TV show in privacy without disturbing others in the same room.
- Completely cordless, simple to use.
- Rich, full sound--virtually interference free.
- Great for the hearing-impaired.
- Works with any TV, VCR, or audio device.



ALG2052
WIRELESS
STEREO HEADPHONES
ONLY \$69.95

PHOTOCOPY PAGE AND DETACH HERE

To order these fine accessories, please fill out this card and return a photocopy to:

Attn: Accessory Offers
Zenith Video Tech Corporation
1000 Milwaukee Avenue
Glenview, Illinois 60025-2493
or call **1-800-255-6790**

Check or money order
(Made payable to Zenith Video Tech Corp.)

Visa Mastercard

Account #

--	--	--	--	--	--	--	--	--	--	--	--	--	--	--	--	--	--

Expiration Date: _____ Signature: _____

IMPORTANT: PLEASE BE SURE TO COMPLETE THE INFORMATION BELOW.

TV Model Number _____ TV Serial Number _____ Mo. Day Yr.
(from sticker on back of unit) (from sticker on back of unit) (Approx. date of purchase.)

PLEASE ALLOW UP TO 3 WEEKS FOR DELIVERY. THANK YOU!

VCRACCS3
6/1/95

ITEM NUMBER	DESCRIPTION	QUANTITY	PRICE PER ITEM	TOTAL PRICE
Sales Tax: Please add your state sales tax if you live in one of the following states.			SUBTOTAL	
CA 7 3/4%, GA 4%, IL 8 3/4%, KS 4.9%, KY 6%, ME 8%, PA 8%, RI 7%, TX 7 3/4%, VA 4 1/2%, WA 8.2%.			STATE SALES TAX	
			SHIPPING & HANDLING	\$4.50
			TOTAL AMOUNT OF ORDER	

SHIP TO:

Telephone: () _____

Name: _____

Address: _____

Apt. # _____ City _____

State _____ Zip Code _____

NOTE: Orders can only be sent to customers within the United States.

YOUR ZENITH WARRANTY

Consumer Protection Plan for Zenith TV

Welcome into the Zenith family! We believe that you will be pleased with your new Zenith Color TV. Please read this Consumer Protection Plan carefully. It is a "LIMITED WARRANTY" as defined under Federal Law. This warranty gives you specific legal rights, and you may also have other rights that vary from state to state within the U.S.A.

Zenith's Responsibility

Service Labor — During a period of 90 days from effective warranty date, Zenith will pay for service labor by a Zenith authorized service center when needed as a result of manufacturing defects.

Parts — New or remanufactured replacements for factory-defective parts will be supplied by a Zenith authorized service center for one year from effective warranty date (color picture tube — two years). Such replacement parts are warranted for the remaining portion of the original warranty period.

Home Service — Warranty service for 19" diagonal (U.S.A.) or larger screen size models is provided in the home in most cases. (Some repairs may require the unit to be taken by the servicer to the repair facility and returned, at no additional charge.)

Not Covered — This warranty covers manufacturing defects and does not cover installation, adjustment of customer controls in the home, installation or repair of home antenna systems, cable converters or cable company-supplied equipment; it also does not cover damage due to misuse, abuse, negligence, acts of God or other causes beyond the control of Zenith. Any alteration of the product after manufacture voids this warranty in its entirety.

Owner's Responsibility

Effective Warranty Date — Warranty begins on the date of original consumer installation. For your convenience, keep the dealers dated bill of sale or delivery ticket as evidence of the purchase date.

Operating Guide — Read your Operating Guide carefully so that you will understand the operation of your set and how to adjust the customer controls.

Carry-In Service — Models under 19" diagonal (U.S.A.) screen size must be taken to a Zenith authorized service center for warranty service and must be picked up by the owner.

Antenna — Reception problems caused by inadequate home antennas or faulty antenna connections are the owner's responsibility.

Important: Product Registration — Please fill out and mail your Product Registration Card. It is imperative that Zenith know how to reach you promptly if we should discover a safety problem that could affect you.

Warranty Service — For warranty service information, contact any Zenith authorized service center. Parts and service labor that are Zenith's responsibility (see above) will be provided without charge. Other service is at the owner's expense. If you have any problem in obtaining satisfactory warranty service, call or write:

Zenith Electronics Corporation
Customer Service Department
1000 Milwaukee Avenue
Glenview, IL 60025
Telephone: (708) 391-8752
Mon-Fri, 8:00 a.m. - 4:30 p.m. Central Time

NOTE: Before you ask for Warranty service, check the Operating Guide section entitled, "MAINTENANCE AND TROUBLESHOOTING." It may be possible to avoid a service call.

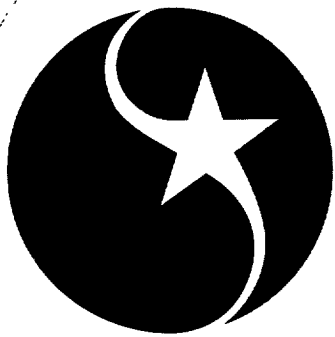

STAR
SIGHT®

Installing StarSight®

Testing StarSight

Using Universal Remote

Using Z-Trak Remote



STAR
SIGHT®

StarSight Telecast, Inc.
39650 Liberty Street
Fremont, CA 94538

Part No. 206-2918-01
Printed in U.S.A.
EP-EDCBA

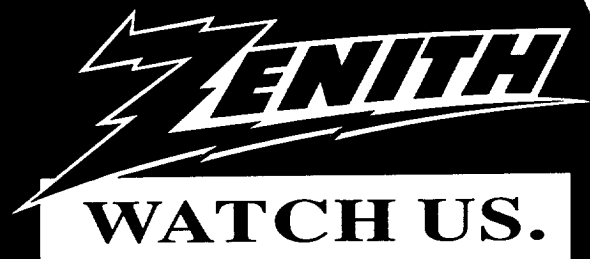



TO BE LICENSED TO USE THE STARSIGHT® SYSTEM AND STARSIGHT FEATURES OF THIS EQUIPMENT, YOU MUST BE REGISTERED WITH STARSIGHT OR AN AUTHORIZED REPRESENTATIVE. LICENSED UNDER U.S. PATENT NUMBERS 4,706,121 AND 5,151,789. USE RIGHTS RESERVED.

STARSIGHT IS NOT IN ANY WAY LIABLE FOR THE ACCURACY OF THE PROGRAM SCHEDULE INFORMATION PROVIDED BY THE STARSIGHT SYSTEM. IN NO EVENT SHALL STARSIGHT BE LIABLE FOR ANY AMOUNTS REPRESENTING LOSS OF PROFITS, OR INDIRECT, SPECIAL, OR CONSEQUENTIAL DAMAGES IN CONNECTION WITH THE PROVISION OR USE OF ANY INFORMATION, EQUIPMENT, OR SERVICE RELATING TO THE STARSIGHT SYSTEM.

© 1995 StarSight Telecast Inc.

StarSight is a trademark of StarSight Telecast.

StarSight is a subscription service.

This Operating Guide may not be duplicated, copied or transferred in any way without prior written permission of StarSight Telecast, Inc.

Patent Statement

The StarSight Guide system and its use are protected by one or more of the following U.S. patents: U.S. Patent No. 4,706,121, U.S. Patent No. 5,151,789; use rights reserved. For licensing and subscription information, call (800) 643-STAR.

Compliance Statement

This device complies with Part 15 of the FCC Rules. Operation is subject to the following two conditions: (1) this device may not cause harmful interference and (2) this device must accept any interference received, including interference that may cause undesired operation.

Trademark Statement

StarSight is a trademark of StarSight Telecast Inc.

**To Activate StarSight
Call (800) 643-STAR**

**For the
StarSight Help
Desk, Call
(800) 628-STAR**

**For Zenith
Customer
Support, Call
(312) 745-5152**

TABLE OF CONTENTS

INTRODUCTION	b	Selecting and de-selecting channels	B-13
Welcome	b	Changing the channel order	B-14
Cable Box and VCR Requirements	b	USING STARSIGHT WITH THE Z-TRAK REMOTE	C-1
INSTALLING STARSIGHT	A-1	Quick Reference Guide	C-1
STEP 1. Fill out the StarSight Checklist	A-1	Getting started with the Z-Trak remote	C-2
STEP 2. Hook-Up Equipment	A-2	Finding out more about what you're watching:	
STEP 3. Activate StarSight	A-6	Channel Pop-Ups	C-4
STEP 4. Checking Your StarSight Setup	A-7	What's on when you change channels: Grazing	C-5
PBS Stations	A-8	What's on without changing channels: Browsing	C-5
Cable Box Codes	A-10	Finding out what's on all channels: Grid Guide	C-6
VCR Codes	A-10	Choosing a program: Tuning from a Guide	C-7
USING STARSIGHT WITH THE UNIVERSAL REMOTE	B-1	Viewing what's on a specific channel: Channel Guide	C-8
Basic Operation	B-1	Choosing programs by category: Theme Guide	C-9
Finding out more about what you're watching: the STAR button	B-2	Recording what you're watching: Current Recording	C-10
What's on when you change channels: Grazing	B-3	Reviewing your schedule of individual recordings:	
What's on without changing channels: Browsing	B-4	Recordings List	C-11
Finding out what's on all channels: Grid Guide	B-5	Reviewing daily or weekly series recordings:	
Viewing what's on a single channel: Channel Guide	B-6	Series Recordings List	C-12
Choosing programs by category: Theme Guide	B-7	How to watch one channel while recording another: Watch and	
Recording what you're watching: Current Recording	B-8	Record	C-12
Scheduling a recording from StarSight guides: Future Recording	B-9	CHANGING YOUR EQUIPMENT SETUP	D-1
Reviewing your schedule of individual recordings:		What you should do when you get a new VCR	D-1
Recordings List	B-10	What you should do when you change your cable box or	
Reviewing daily or weekly series recordings:		service or when you move	D-2
Series Recordings List	B-11	TROUBLESHOOTING	E-1
How to watch one channel while recording another:		Before calling for service	E-1
Watch and record	B-12		

How to use this operating guide

StarSight installation and operation is given in this portion of the operating guide. Follow the procedures given if you are going to use StarSight.

 Refer to the TV portion of this operating guide for TV installation and operation without StarSight.

INTRODUCTION

Welcome

Welcome to StarSight, an innovative way to locate programs and manage the many channels that you receive. With StarSight, you can:

- See an instant description of what's on any channel.
- Select a program from a list that displays your favorite types of shows by theme (movies, sports, comedies, etc.).
- Get information about plots, casts, content ratings, and running times.
- Tune from an on-screen guide right to the program you selected.
- Program your VCR with the touch of one button.
- Re-arrange the order of your channels to put your favorites first.

Cable Box and VCR Requirements.

Be sure to read these requirements carefully. They contain important information you need to ensure that StarSight performs properly.

- A VCR is required for recording capability. To take full advantage of StarSight, your VCR must be controllable by a wireless infrared remote control. Otherwise, StarSight can still provide program information, but will not be able to automatically tune to or record a specific program on your VCR.
- If your VCR remote control does not have a number pad with at least 10 digits, StarSight will be unable to tune the VCR.
- If you have a Cable Box, it must be controllable by a wireless infrared remote control.
- Your Cable company should be able to provide a remote-controlled Cable Box, if you do not already have one.
- Your StarSight-equipped television is not designed to operate with, or control, a satellite dish. For information on StarSight products specifically designed for satellite systems, see your local satellite dealer.

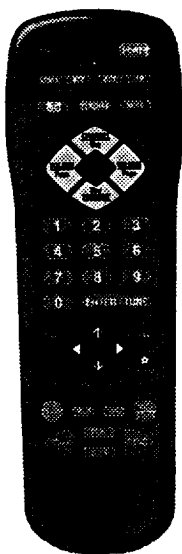

Universal Remote

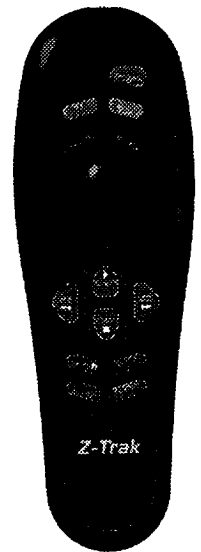
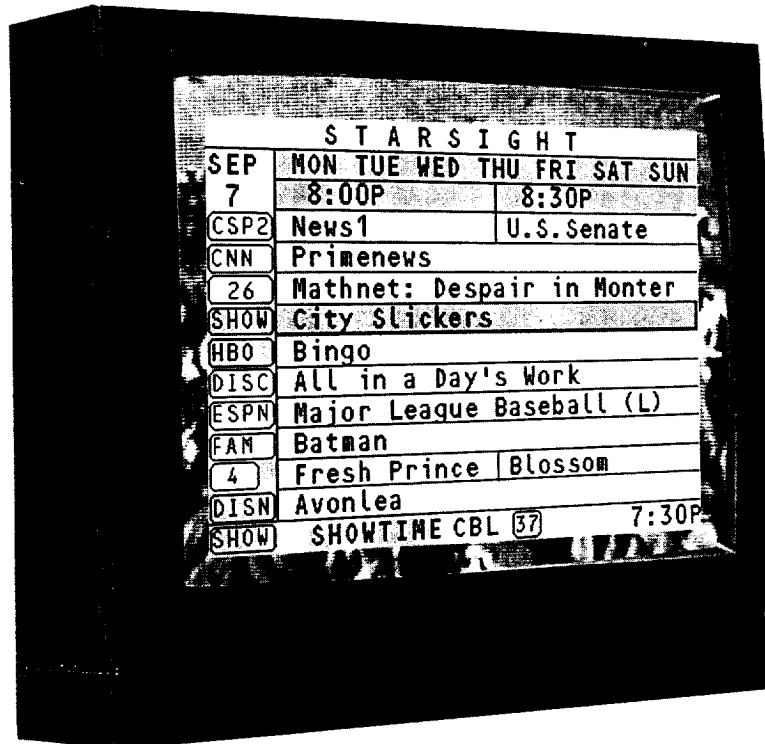

Z-Trak Remote

INSTALLING STARSIGHT

StarSight must be installed properly for you to enjoy all of its benefits. To ensure proper installation, follow the procedure in this section in the order they are presented.

STEP 1. Fill out the StarSight Checklist.

STARSIGHT CHECKLIST

Complete sections A and B, and keep this checklist close at hand during subscription.

A **PBS Station:** Consult the table of PBS Stations, located at the end of this section.

Find the PBS station that is closest to your city. (If you receive two or more stations, select the one with the clearest picture.) Write the PBS Station letters and channel number below.

PBS Station Letters: _____

PBS Station Channel Number: _____

For Cable Users Only: Check your Cable company's channel line-up or your local newspaper's TV listings to see if the PBS station in your area has a different channel number from the one you wrote down above.

If so, write your PBS station's Cable channel number here: _____

(You will use this channel number during the Setup process.)

B **Code Numbers:** Consult the table of Cable Box Codes and VCR Codes, located at the end of this section.

Find the code numbers that apply to your brands of Cable Box and VCR and write them below.

CABLE BOX

Code 1: _____ Code 2: _____ Code 3: _____

Code 4: _____ Code 5: _____ Code 6: _____

VCR

Code 1: _____ Code 2: _____ Code 3: _____ Code 4: _____

Code 5: _____ Code 6: _____ Code 7: _____ Code 8: _____

Now proceed to "Step 2. Hook-Up Equipment."

C **During Subscription...** StarSight will display on-screen your personal STAR number and I.D. number. When these numbers appear on your TV screen, write them here.

Star # _____

I.D. # _____

INSTALLING STARSIGHT

STEP 2. Hook-Up Equipment.

There are four possible choices for hooking up your equipment. Only one of these choices will apply to your particular equipment setup.

Turn to the appropriate Setup and follow the instructions, then proceed to "STEP 3. Activate StarSight."

If you have...	Turn to
TV Only	Setup 1
TV and Cable Box	Setup 2
TV and VCR	Setup 3
TV, VCR and Cable Box	Setup 4

Setup 1: TV Only

If you receive your television signal by antenna or basic Cable TV (no Cable Box):

1. Attach the cable coming out of the wall **A** to the "ANT/CABLE 1" jack on the back of your TV.
2. Plug your TV into a power outlet not controlled by a light switch and turn your TV on.
3. Proceed to "Step 3. Activate StarSight."

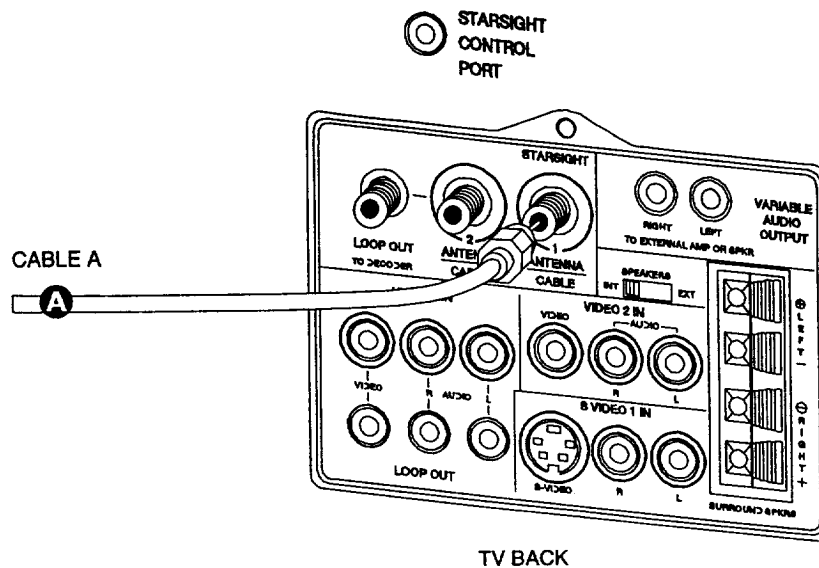

INSTALLING STARSIGHT

Setup 2: TV and Cable Box

NOTE: DO NOT UNPLUG YOUR CABLE BOX AT ANY TIME.

1. Turn off, but do not unplug, your Cable Box.
2. Attach the cable coming out of the wall **A** to your Cable Box's "Input" or "Cable In" jack.
3. Attach an RF cable **B** to your Cable Box's "Output" or "TV Set" jack, and the other end of this cable to the "ANT/CABLE 1" jack on the back of your TV.
4. Take the Remote Emitter — it's a wire with a plug at one end and two plastic bulbs at the other ends — and push the plug of the Remote Emitter wire into the "StarSight Control Port" on the back of the TV. Run the Remote Emitter wire **C** under the Cable Box and place either one of the plastic bulbs about two inches in front of the front panel of the Cable Box **D**. Make sure that the plastic bulb is facing the front panel of the Cable Box (see diagram below). Do not adhere the Remote Emitter at this time. After you have completed subscribing to StarSight, and you have confirmed the correct code that operates your Cable Box, you can peel off the backing of the sticker on the Remote Emitter and adhere it permanently.
5. Turn on your Cable Box.
6. Plug your TV into a power outlet not controlled by a light switch.

NOTE: DO NOT PLUG YOUR TV INTO THE BACK OF YOUR CABLE BOX.

7. Tune your Cable Box to the PBS channel listed on your StarSight Checklist.
8. Turn on your TV. Using the number pad on your Universal TV remote control, tune your TV to the channel that allows you to watch Cable TV, usually channel 3 or 4. If these channels don't show your Cable TV service, then try putting your TV on channel 2, 5, or 6.
9. Proceed to "Step 3. Activate StarSight."

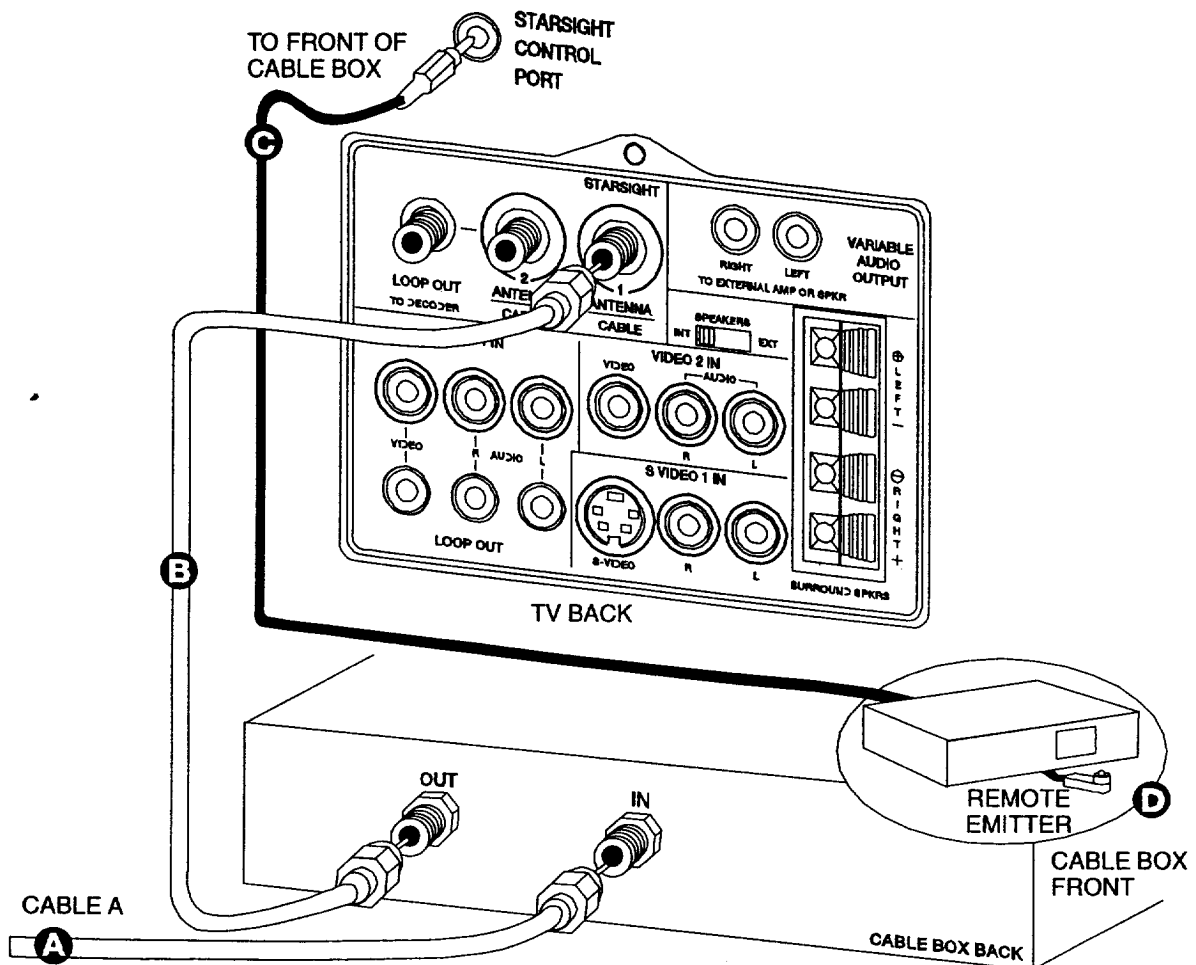

INSTALLING STARSIGHT

Setup 3: TV and VCR

1. Attach the cable coming out of the wall **A** to the "VHF In" (FROM ANTENNA) jack of your VCR.
2. Attach an RF cable **B** to your VCR's "VHF Out" (TO TV) jack, and the other end of this cable to the "ANT/CABLE 1" jack on the back of your TV.
3. Take the Remote Emitter — it's a wire with a plug at one end and two plastic bulbs at the other ends — and push the plug of the Remote Emitter wire **C** into the "StarSight Control Port" on the back of the TV. Run the Remote Emitter wire under the VCR and place either one of the plastic bulbs about two inches in front of the front panel of the VCR. Make sure that the plastic bulb is facing the front panel of the VCR **D**. Do not adhere the Remote Emitter at this time. After you have completed activating StarSight, and you have confirmed the correct code that operates your VCR you can peel off the backing of the sticker on the Remote Emitter and adhere it permanently.
4. Locate the section on the back of your TV labeled "Video 1 In." Attach the three Audio/Video cables to the "Video," "Audio R" and "Audio L" jacks and attach the other ends of the cables to the corresponding "Video Out," "Audio R Out" and "Audio L Out" jacks on the back of your VCR. This is necessary if...
 - You have a VCR without a front panel channel indicator that uses an on-screen display.
 - You have a stereo VCR and would like to take advantage of the stereo feature.
 - You would like to take advantage of PIP.
5. Plug your VCR into a power outlet and leave it off.
6. Plug your TV into a power outlet not controlled by a light switch and turn your TV on.
7. Proceed to "Step 3. Activate StarSight."

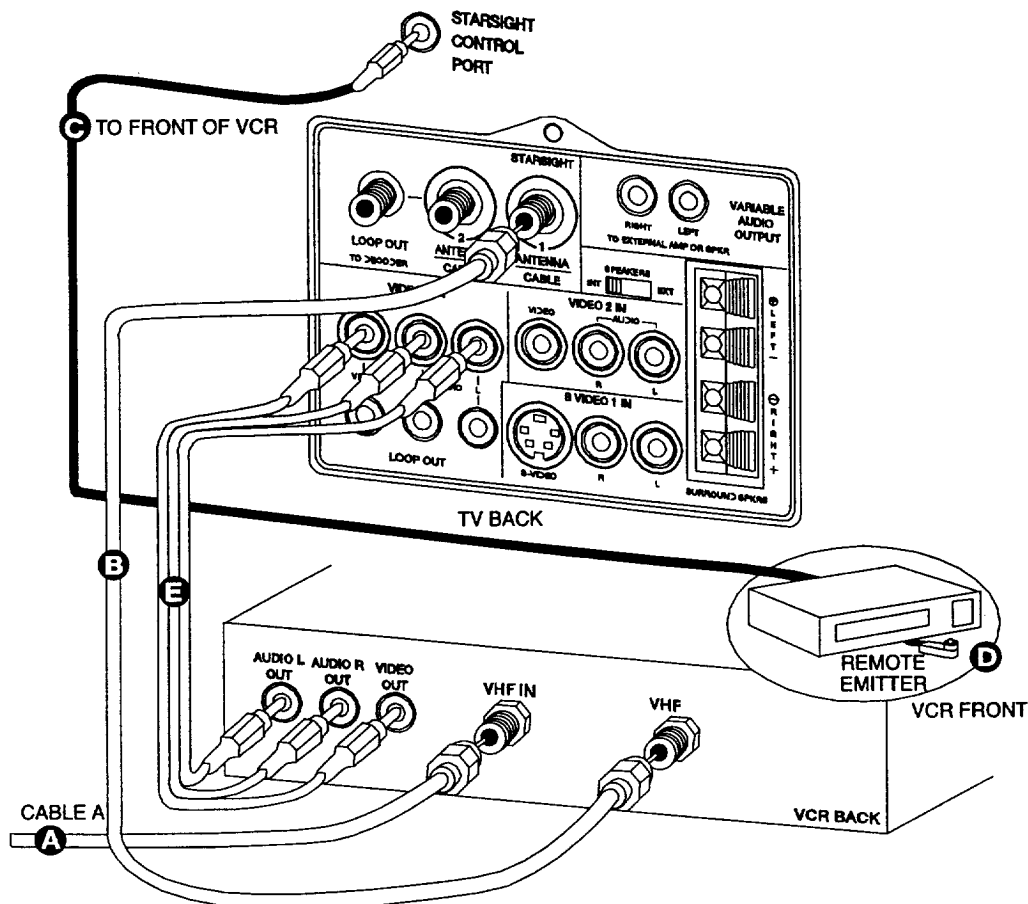

INSTALLING STARSIGHT

Setup 4: TV and VCR and Cable Box

NOTE: DO NOT UNPLUG YOUR CABLE BOX AT ANY TIME.

1. Turn off your Cable Box.
2. Attach the cable coming out of the wall **A** to the "ANT/CABLE 2" jack on the back of your TV.
3. Attach an RF cable **B** to your TV's "LOOP OUT TO DECODER" jack, and the other end of this cable to your Cable Box's "Input" or "Cable In" jack.
4. Attach an RF cable **C** to your Cable Box's "Output" or "TV Set" jack, and the other end of this cable to the "VHF In" (FROM ANTENNA) jack of your VCR.
5. Attach an RF cable **D** to your VCR's "VHF Out" (TO TV) jack, and the other end of this Cable to the "ANT/CABLE 1" jack on the back of your TV.
6. Take the Remote Emitter — it's a wire with a plug at one end and two plastic bulbs at the other ends — and push the plug of the Remote Emitter **E** wire into the "StarSight Control Port" on the back of the TV. Run one Remote Emitter wire under the VCR and place one of the plastic bulbs about two inches in front of the front panel of the VCR **F**. Make sure that the plastic bulb is facing the front panel of the VCR. Do the same for the Cable Box. Do not adhere the Remote Emitters at this time. After you have completed activating StarSight, and you have confirmed the correct codes that operate your VCR and Cable Box, you can peel off the backing of the stickers on the Remote Emitters and adhere them permanently.
7. Locate the section on the back of your TV labeled "Video 1 In." Attach the three Audio/Video cables to the "Video," "Audio R" and "Audio L" jacks and attach the other ends of the cables to the corresponding "Video Out," "Audio R Out" and "Audio L Out" jacks on the back of your VCR. This is necessary if...
 - You have a VCR without a front panel channel indicator that uses an on-screen display.
 - You have a stereo VCR and would like to take advantage of the stereo feature,
 - You would like to take advantage of PIP.

8. Plug your VCR into a power outlet and leave it off.
9. Turn on your Cable Box.
10. Plug your TV into a power outlet not controlled by a light switch.

NOTE: DO NOT PLUG YOUR TV INTO THE BACK OF YOUR CABLE BOX.

11. Tune your Cable Box to the PBS channel listed on your StarSight Checklist.
12. Turn on your TV. Using the number pad on your Universal TV remote control, tune your TV to the channel that allows you to watch Cable TV, usually channel 3 or 4. If these channels don't show your Cable TV service, then try putting your TV on channel 2, 5, or 6.
13. Proceed to Installation "Step 3. Activate StarSight."

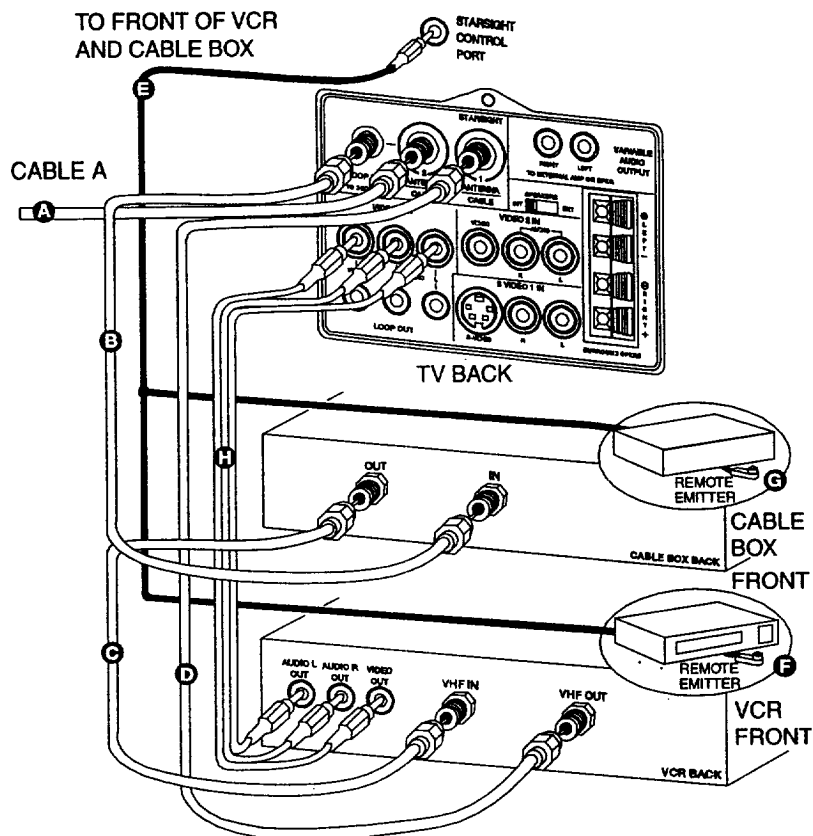

INSTALLING STARSIGHT

PBS Stations

City	Station	Channel	City	Station	Channel	City	Station	Channel
Alabama			Georgia			Louisiana		
Anniston	WCIQ	7	Albany	WABW	14	Alexandria	KLPA	25
Birmingham	WBIQ	10	Atlanta	WGTV	8	Baton Rouge	WLPB	27
Dothan	WGIQ	43	Augusta	WCES	20	El Dorado	KLTM	13
Decatur	WHIQ	25	Chatsworth	WCLP	18	Lafayette	KLPB	27
Huntsville	WHIQ	25	Columbus	WJSP	28	Lake Charles	KLTL	18
Mobile	WEIQ	42	Dawson	WACS	25	Monroe	KLTM	13
Montgomery	WAIQ	26	Macon	WDGO	15	New Orleans	WYES	12
Alaska			Savannah	WVAN	9	Shreveport	KLTS	24
Anchorage	KAKM	7	Waycross	WXGA	8	Maine		
Fairbanks	KUAC	9	Hawaii			Bangor	WMEB	12
Arizona			Honolulu	KHET	11	Calais	WMED	13
Phoenix	KAET	8	Waikiki	KMEB	10	Lewiston	WCBB	10
Tucson	KUAT	6	Idaho			Presque Isle	WMEM	10
California			Boise	KAID	4	Maryland		
Eureka	KEET	13	Idaho Falls	KISU	10	Annapolis	WMPT	22
Fresno	KVPT	18	Twin Falls	KITT	13	Baltimore	WMPB	67
Los Angeles	KCET	28	Illinois			Frederick	WFPT	62
Monterey	KTEH	54	Carbondale	WSIU	8	Hagerstown	WWPB	31
Sacramento	KVIE	6	Champaign	WILL	12	Oakland	WGPT	36
Salinas	KTEH	54	Chicago	WTTW	11	Salisbury	WCPB	28
San Diego	KPBS	15	Moline	WQPT	24	Massachusetts		
Santa Barbara	KCET	28	Peoria	WTVP	47	Boston	WGBH	2
San Francisco	KQED	9	Quincy	WQEC	27	Springfield	WGBY	57
San Jose	KQED	9	Rock Island	WQPT	24	Holyoke	WGBY	57
Stockton	KVIE	6	Springfield	WILL	12	Michigan		
Redding	KIXE	9	Indiana			Alpena	WCML	6
Visalia	KVPT	18	Elkhart	WNIT	34	Bad Axe	WUCX	35
Colorado			Evansville	WNIN	9	Bay City	WUCM	19
Colorado Springs	KTSC	8	Fort Wayne	WFWA	39	Detroit	WTVS	56
Denver	KRMA	6	Lafayette	WFYI	20	Flint	WFUM	28
Pueblo	KTSC	8	Indianapolis	WFYI	20	Grand Rapids	WGVU	35
Connecticut			South Bend	WNIT	34	Kalamazoo	WGVU	35
Bridgeport	WEDW	49	Vincennes	WVUT	22	Lansing	WGVK	52
Hartford	WEDH	24	Iowa			Marquette	WTKR	23
New Haven	WEDY	65	Ames	KDIN	11	Marquette	WNMU	13
Norwich	WEDN	53	Cedar Rapids	KIIN	12	Mount Pleasant	WCMU	14
Delaware			Council Bluffs	KBIN	32	Saginaw	WFUM	28
Seaford	WDPB	64	Davenport	KQCT	36	Traverse City	WCMW	21
Wilmington	WHYY	12	Des Moines	KDIN	11	Minnesota		
Dist. of Columbia			Fort Dodge	KTIN	21	Austin	KYIN	24
Washington, D.C.	WETA	26	Fort Dodge	KTIN	21	Duluth	WDSE	8
Florida			Iowa City	KIIN	12	La Crescent	WHLA	31
Daytona Beach	WMFE	24	Mason City	KYIN	24	Mason City	KYIN	24
Ft. Lauderdale	WPBT	2	Red Oak	KHIN	36	Minneapolis-		
Ft. Myers	WSFP	30	Sioux City	KSIN	27	St. Paul	KTCI	17
Gainesville	WUFT	5	Waterloo	KRIN	32	Superior	WDSE	8
Jacksonville	WJCT	7	Kansas			Mississippi		
Miami	WPBT	2	Hutchinson	KOOD	9	Biloxi	WMAH	19
Naples	WSFP	30	Lakin	KSWK	3	Bude	WMAU	17
Orlando	WMFE	24	Topeka	KTWU	11	Columbus	WMAB	2
Panama City	WFSG	56	Kentucky			Gulfport	WMAH	19
Pensacola	WSRE	23	Bowling Green	WKYU	24	Greenville	WMAO	23
Tampa	WEDU	3	Cape Girardeau	WSIU	8	Greenwood	WMAO	23
St. Petersburg	WEDU	3	Lexington	WKLE	46	Jackson	WMPN	29
Tallahassee	WFSU	11	Louisville	WKPC	15	Meridian	WMAW	14
Thomasville	WFSU	11	Paducah	WSIU	8	Oxford	WMAV	18
West Palm Beach	WXEL	42	Tri-Cities	WSBN	47			

(Continued on next page)

INSTALLING STARSIGHT

PBS Stations

City	Station	Channel	City	Station	Channel	City	Station	Channel
Missouri			Minot	KBME	3	Jackson	WLJT	11
Hannibal	WQEC	27	Williston	KSRE	6	Knoxville	WKOP	15
Joplin	KOZJ	26		KWSE	4	Memphis	WKNO	10
Kansas City	KCPT	19	Ohio			Nashville	WDCN	8
Springfield	KOZK	21	Akron	WVIZ	25	Texas		
St. Louis	KETC	9		WEAU	49	Amarillo	KACV	2
Montana			Cleveland	WVIZ	25	Austin	KLRU	18
Bozeman	KUSM	9	Cincinnati	WCET	48	Corpus Christi	KEDT	16
Butte	KUSM	9	Columbus	WOSU	34	Dallas	KERA	13
Nebraska			Dayton	WPTD	16	El Paso	KCOS	13
Bassett	KMNE	7	Lima	WBGU	27	Ft. Worth	KERA	13
Hastings	KUON	12	Portsmouth	WPBO	42	Harlingen	KMBH	60
	KHNE	29	Steubenville	WOUC	44	Houston	KUHT	8
Lexington	KLNE	3	Toledo	WGTE	30	Lubbock	KTXT	5
Lincoln	KUON	12	Youngstown	WNEO	45	Odessa Midland	KOCV	36
Merriman	KRNE	12	Oklahoma			San Antonio	KLRN	9
Norfolk	KXNE	19	Cheyenne	KWET	12	Temple	KNCT	46
North Platte	KPNE	9	Eufaula	KOET	3	Waco	KNCT	46
Omaha	KYNE	26	Oklahoma City	KETA	13	Utah		
Scottsbluff	KTNE	13	Tulsa	KOED	11	Salt Lake City	KUED	7
Nevada			Oregon			Vermont		
Las Vegas	KL VX	10	Bend	KOAB	3	Burlington	WC FE	57
Reno	KNPB	5	Eugene	KEPB	28	Virginia		
New Hampshire			Klamath Falls	KFTS	22	Arlington	WETA	26
Durham	WENH	11	Medford	KSYS	8	Charlottesville	WHTJ	41
	WNET	13	Portland	KOPB	10	Harrisonburg	WVPT	51
Keene	WEKW	52	Pennsylvania			Lynchburg	WBRA	15
Littleton	WLED	49	Altoona	WPSX	3	Norfolk	WHRO	15
New Jersey			Erie	WQLN	54	Norton	WSBN	47
N. New Jersey	WNET	13	Harrisburg	WITP	33	Petersburg	WCVE	23
S. New Jersey	WHYY	12	Johnstown	WPSX	3	Portsmouth	WHRO	15
New Mexico			Lancaster	WITF	33	Richmond	WCVE	23
Albuquerque	KNME	5	Philadelphia	WHYY	12	Roanoke	WBRA	15
Santa Fe	KNME	5	Pittsburgh	WQED	13	Washington		
New York			Scranton	WVIA	44	Seattle	KCTS	9
Albany-			Wilkes-Barre	WVIA	44	Spokane	KSPS	7
Schenectady	WMHT	17	Rhode Island			Tacoma	KCTS	9
Binghamton	WSKG	46	New Bedford	WSBE	36	Yakima	KYVE	47
Buffalo	WNED	17	Providence	WSBE	36	West Virginia		
New York	WNET	13	South Carolina			Beckley	WSWP	9
Norwood	WNPI	18	Allendale	WEBA	14	Bluefield	WSWP	9
Plattsburgh	WCFE	57	Beaufort	WJWJ	16	Charleston	WPBY	33
Rochester	WXXI	21	Charleston	WITV	7	Clarkburg	WNPB	24
Syracuse	WCNY	24	Columbia	WRLK	35	Huntington	WPBY	33
Watertown	WNPE	16	Conway	WHMC	23	Parkersburg	WOUB	20
North Carolina			Florence	WJPM	33	Weston	WNPB	24
Asheville	WUNF	33	Greenville	WNTV	29	Wheeling	WOUC	44
Charlotte	WUNG	58	Greenwood	WNEH	38	Wisconsin		
Columbia	WUND	2	Huntington	WPBY	33	Appleton	WPNE	38
Greenville	WUNK	25	Rock Hill	WNSC	30	Eau Clair	WHLA	31
Greensboro	WUNL	26	Spartanburg	WRET	49	Green Bay	WPNE	38
Jacksonville	WUNM	19	Sumter	WRJA	27	La Crosse	WHLA	31
Linville	WUNE	17	South Dakota			Madison	WHA	21
Raleigh-Durham	WUNC	4	Aberdeen	KDSD	16	Menomonie	WHWC	28
Roanoke Rapids	WUNP	36	Brookings	KESD	8	Milwaukee	WMVS	10
Wilmington	WUNJ	39	Eagle Butte	KPSD	13	Park Falls	WLEF	36
North Dakota			Lowry	KQSD	11	Rhineland	WHRM	20
Bismarck	KBME	3	Martin	KZSD	8	Wassau	WHRM	20
Drakinson	KDSE	9	Pierre	KTSD	10	Wyoming		
Ellendale	KJRE	19	Rapid City	KBHE	9	Cheyenne	KTNE	13
Fargo	KFME	13	Vermillion	KUSD	2	Evanston	KUED	7
Grand Forks	KGFE	2	Tennessee					
			Chattanooga	WTCT	45			

INSTALLING STARSIGHT

Cable Box Codes

Cable Box Brand	Code	Cable Box Brand	Code	Cable Box Brand	Code
Allegro	62	Northcoast	75	Standard Components	35
GE	67	NSC	35, 39, 68, 69, 70	Texscan	39, 56, 71
Gemini	05, 31, 38	Oak	11, 32, 42	Tocom	17, 18, 46
General Instrument	04, 05, 06, 07, 08, 09, 10, 18, 60	Panasonic	13, 20	Unika	48, 62
Hamlin	02, 45, 65, 66	Philips	47, 50, 52, 54, 55	Universal	58, 62
Jerrol	04, 07, 08, 09, 10, 18, 60	Pioneer	15, 43	Video Way	49
Kale Vision	35	Regency	29	Vid Tech	40
Macom	21	Samsung	35	Viewstar	54, 55, 72
Magnavox	34	Scientific Atlanta	16, 23, 36, 64	Zenith	01
		Signal	76	Zenith HT-2000	19
		Sprucer	13		

VCR Codes

VCR Brand	Code	VCR Brand	Code	VCR Brand	Code
Admiral	08, 61	Jerrol	18	Samsung	20
Adventura	31	JVC	02, 25, 58	Sansui	39
Aiwa	31	Kenwood	02	Sanyo	06, 12, 47
Akai	23, 38, 41	Logik	39	Scott	04, 05, 33, 43
Audio Dynamics	02, 18	LXI	09, 31	Sears	06, 09, 11, 12, 15
Bell & Howell	06, 47	Magnavox	07, 14, 31	Sharp	08, 61
Broksonic	21, 26, 50, 55	Marantz	07, 18	Shintom	39
Canon	14	Marta	09	Signature 2000	08, 14, 16, 31, 49
Citizen	09	Memorex	06, 12, 14, 31	Sony Video8	17
Craig	12	Mitsubishi	04, 22	Sony VHS	32
Curtis Mathes	14, 59	Montgomery Ward	08, 14, 16, 31, 49	Sony	32, 37
Daewoo	46, 48, 54	Multi Tech	39	Sony Beta	37
Daytron	46	NEC	02, 18	Sylvania	07, 14, 27
DBX	02, 18	Orion	50	Symphonic	31
Emerson	03, 21, 23, 26, 33, 35, 43, 50	Panasonic	14, 51, 59	Tashiko	09
Fisher	11, 12, 13, 47	Pentax	15	Tatung	02
Funai	31	Philco	07, 14	Teac	02, 31
General Electric	14, 16, 20	Philips	07, 14, 27	Teknika	09, 34
Go Video	56, 62, 63	Pioneer	10, 15	Toshiba	05, 15
Goldstar	01, 09	Portland	46	Vector Research	04, 18
Hitachi	15, 57	Proscan	16, 60	Yamaha	02, 18
Instant Replay	14, 27	Quasar	14, 59	Zenith	00
JC Penney	14, 15, 18, 27	RCA	15, 16, 20, 27, 60	Zenith VHS	01, 24, 25
		Realistic	06, 08, 12, 14, 31	Zenith Beta	37

USING STARSIGHT WITH THE UNIVERSAL REMOTE

Basic Operation

This section of the guide discusses the use of StarSight with the Universal Remote. The following illustration shows the Universal Remote and its controls.

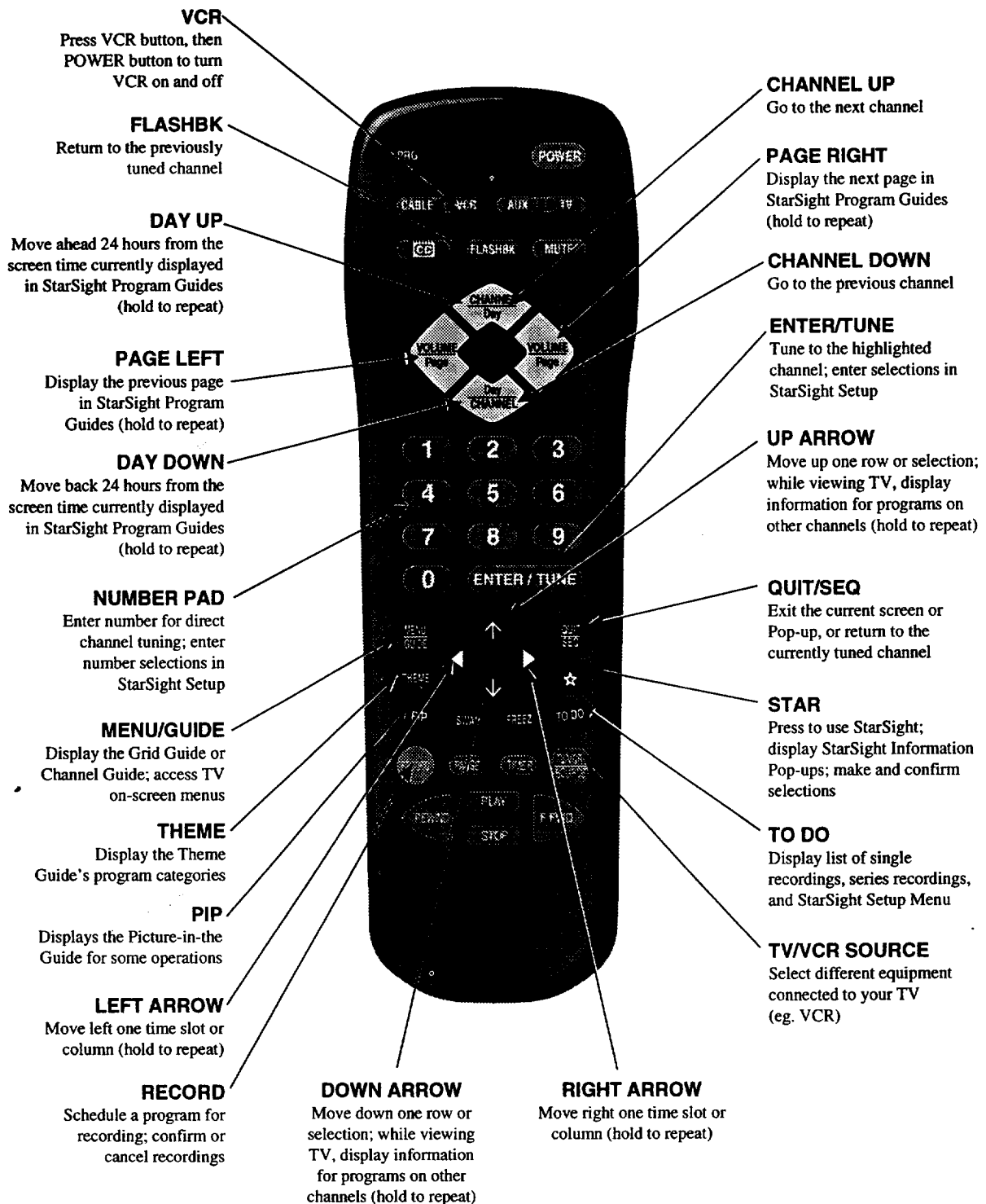

USING STARSIGHT WITH THE UNIVERSAL REMOTE

Finding out more about what you're watching: the STAR button

1. Press the STAR button. You'll see the program title and time remaining "Pop up" for five seconds.

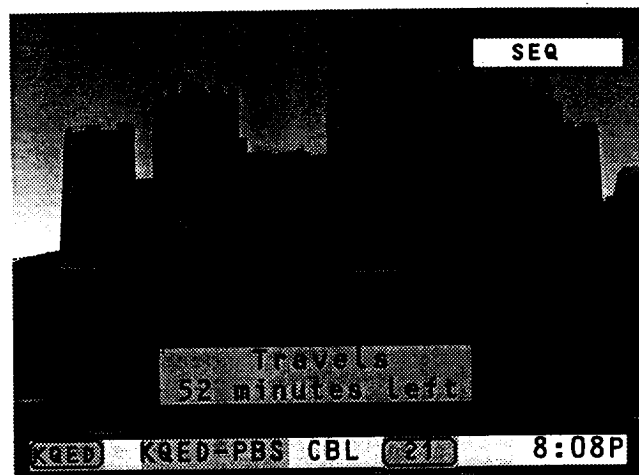

2. Press STAR again. The Pop-up changes to provide more detailed information. (It goes away in 30 seconds.) Or...

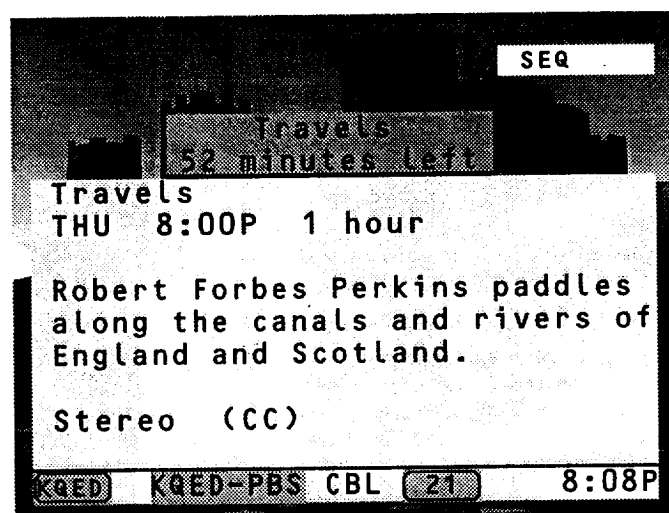

3. Press STAR again to resume watching TV.

YOU SHOULD ALSO KNOW...

- If at any time you find you cannot activate the StarSight functions, just press the STAR button.

USING STARSIGHT WITH THE UNIVERSAL REMOTE

What's on when you change channels: Grazing

1. Press CHANNEL/Day Up or Down to change channels. The Pop-up for the new program automatically displays and then disappears in five seconds.
2. Press STAR while the Pop-up is displayed to get even more information on the program.

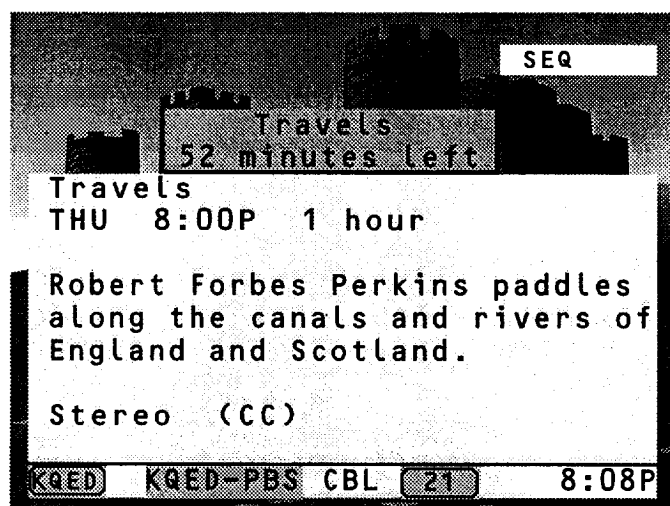
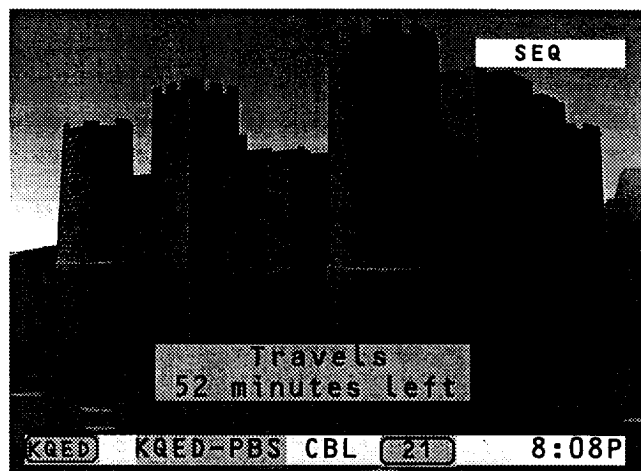

3. Press STAR again to resume watching TV.

YOU SHOULD ALSO KNOW...

- If you press STAR twice and then change channels, you will get full program descriptions while you are channel surfing. (Does not apply to Cable Box Setups.)

USING STARSIGHT WITH THE UNIVERSAL REMOTE

What's on without changing channels: Browsing

1. Press ↑ or ↓ to see what's on other channels. Notice that you will continue to see your presently tuned program, but will get a Pop-up for a program on a different channel.
2. Press ↑ or ↓ as many times as you'd like (or hold to repeat) to see Pop-ups for different programs.
3. Press STAR while the Pop-up is displayed to get even more information on the program.
4. Press STAR again. The Pop-up disappears.

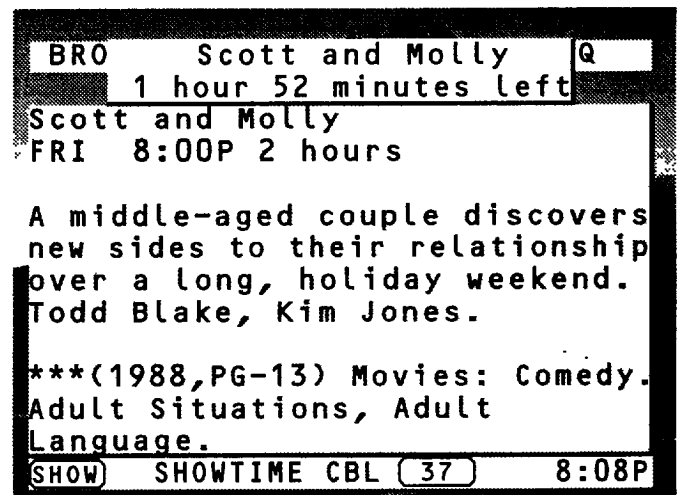
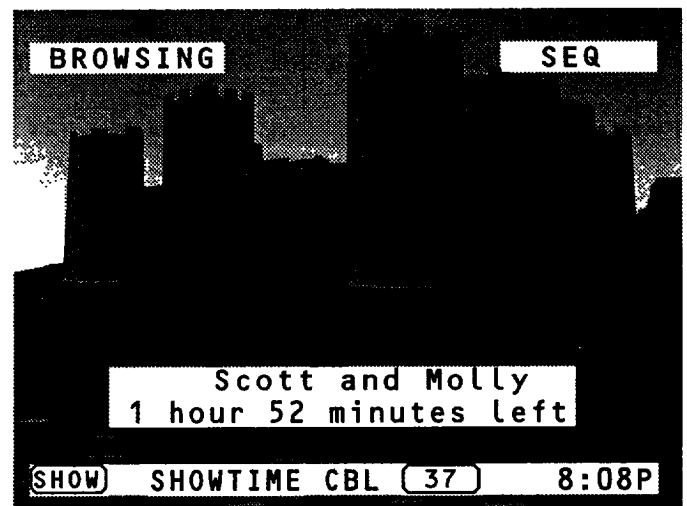
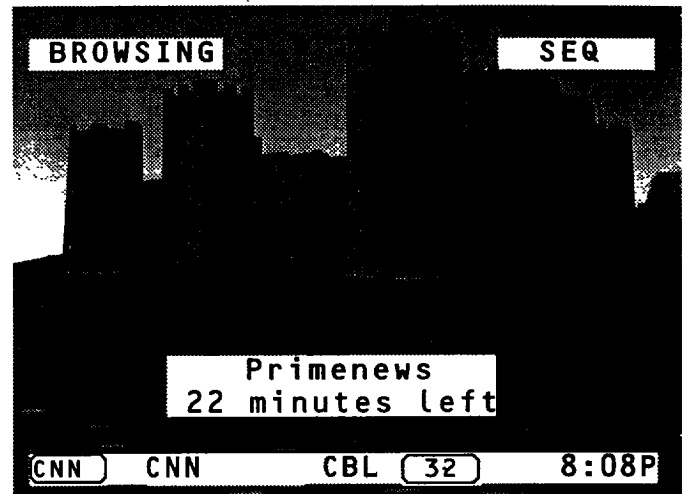

YOU SHOULD ALSO KNOW...

- Press ENTER/TUNE to go directly to the program in the Pop-up.
- If the PIP window is displayed, press the STAR button and then press ↑ or ↓ to browse channels.
- The program title Pop-up appears in yellow for the currently tuned program.

USING STARSIGHT WITH THE UNIVERSAL REMOTE

Finding out what's on all channels: Grid Guide

Using the StarSight Grid Guide to see:

- what's on right now
 - what's on for the next seven days
 - what the programs are about
1. Press MENU/GUIDE to see a full listing of all programs. (Remember: If the Grid Guide doesn't appear, you may not be in StarSight mode. Just press STAR.)
 2. Press ◀, ▶, ↑, or ↓ to move the highlight bar around the Grid Guide.
 3. Press STAR any time to get information about the highlighted show.
 4. Press PIP to view the currently highlighted show.
 5. Press ENTER/TUNE to tune to any currently highlighted show.
 6. Press QUIT/SEQ to resume watching TV.

S T A R S I G H T

SEP	MON						
7							
CSP2	U.S. Senate Coverage						
CNN	Larry King Live!						
26	Math ... Who Needs It?						
SHOW	Scott and Molly						
HBO	Bingo						Home Alone
DISC	All In A Day's Work						
ESPN	Major League Baseball (L)						
FAM	Batman						
4	In the Best of Times						
DISN	Casablanca						
REQ	The Prince of Tides						
26	WETA-PBS CBL	(26)					9:00P

S T A R S I G H T

SEP	MON	TUE	WED	THU	FRI	SAT	SUN
7							
CSP2	U.S. Senate Coverage						
CNN	Larry King Live!						
26	Math ... Who Needs It?						
SHOW	Scott and Molly						
	Math ... Who Needs It?						
	MON 9:00P 1 hour						
A large number of people with exciting jobs use math every day in their work.							
Education (CC)							
26	WETA-PBS CBL	(26)					9:00P

S T A R S I G H T

SEP	MON	TUE	WED	THU	FRI	SAT	SUN
7							
CSP2	U.S. Senate Coverage						
CNN	Larry King Live!						
26	Architects of India						
SHOW	Scott and Molly						
HBO	Bingo						
DISC	All in a Day's Work						
ESPN	Major League Ba						
FAM	Batman						
4	Fresh Prince						
DISN	Avonlea						
REQ	The Prince of						
26	WETA-PBS CBL	(26)					9:00P



YOU SHOULD ALSO KNOW...

- Press numbers followed by ◀ or ▶ to move to a specific time in the guide.
- Press RECORD to record any highlighted show.
- Press VOLUME/Page Left or Right to see additional channel listings.
- Press CHANNEL/Day Up or Down to see different days for the same time.
- If you have a cable box, the PIP window will only show your presently tuned channel.

USING STARSIGHT WITH THE UNIVERSAL REMOTE

Viewing what's on a single channel: Channel Guide

Do you have a favorite channel? Showtime? Nickelodeon?

Whatever it is, StarSight can show you a channel's schedule for an entire week.

1. Press MENU/GUIDE to see the Grid Guide.
2. Press ↑ or ↓ to move the highlight bar to the channel you want to know about.
3. Press MENU/GUIDE again to see the Channel Guide for the channel you highlighted.
4. Press VOLUME/Page Right to see more programs on the same channel.
5. Press ENTER/TUNE to tune to a current program.
6. Press QUIT/SEQ to resume watching TV.

YOU SHOULD ALSO KNOW...

- Press STAR to learn more about a program.
- Press CHANNEL/Day Up or CHANNEL/Day Down to see the Channel Guide for other channels.
- Press MENU/GUIDE to go back and forth between the Channel Guide and Grid Guide.
- Press RECORD to record any highlighted show.

S T A R S I G H T	
SEP	MON
7	
CSP2	News 1 U.S. Senate
CNN	PrimeneWS
26	Mathnet: Despair in Monterey
SHOW	Scott and Molly
HBO	Bingo
DISC	All in a Day's Work
ESPN	Major league Baseball (L)
FAM	Batman
4	Fresh Prince Blossom
DISN	Avonlea
REQ	The Prince of Tides
CNN	CNN CBL 6 7:25P

WHAT'S NEXT ON CNN	
MON SEP 7	
7:00P	Moneyline
7:30P	Crossfire
8:00P	PrimeneWS
9:00P	Larry King Live!
10:00P	World News
11:00P	Sports Tonight
11:30P	Moneyline
12:00A	Newsnight
12:30A	Inside Politics '92
1:00A	Showbiz Today
1:30A	Newsnight Update
2:00A	Worldwide Update
CNN	CNN CBL 6 7:25P

USING STARSIGHT WITH THE UNIVERSAL REMOTE

Choosing programs by category: Theme Guide

What's your favorite kind of program?

Sports? Movies? Comedies? StarSight gives you a selection of categories to help you pick your favorite shows for the coming week.

1. Press THEME to see the StarSight Themes menu.
2. Press ↑ or ↓ to highlight a Theme.

3. Press STAR to see the categories for that Theme.
4. Press ↑ or ↓ to highlight a category.

5. Press STAR to see the shows for that category. Press VOLUME/Page Right to see additional show listings.
6. Press ENTER/TUNE to tune to a current program.
7. Press QUIT/SEQ repeatedly to resume watching TV.

YOU SHOULD ALSO KNOW...

- Press STAR to learn more about a program.
- Press MENU/GUIDE to go directly to the Grid Guide from any Theme Guide.
- Press RECORD to record any highlighted show.

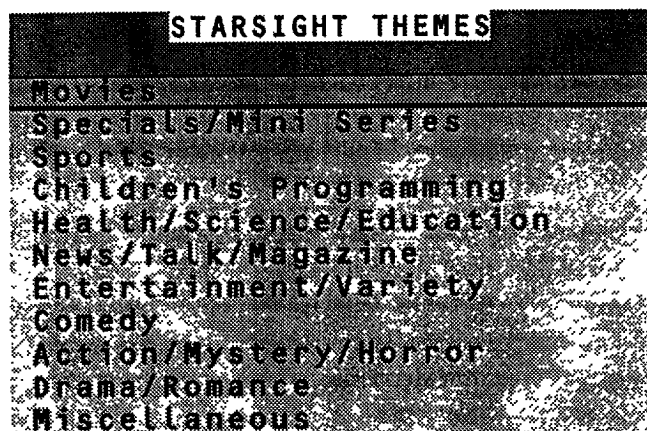

CSP2 CSPAN2 CBL 27 7:41P

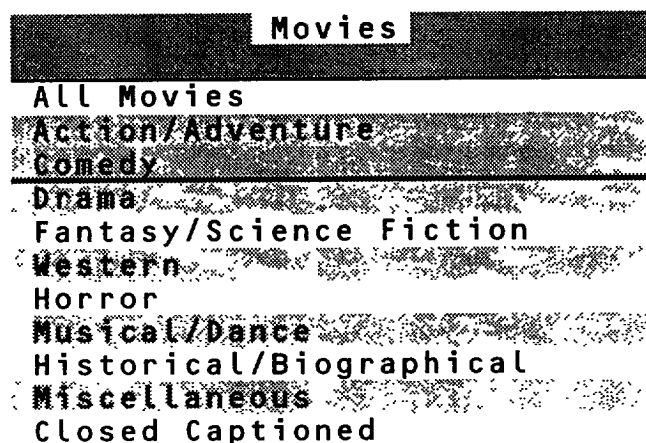

CSP2 CSPAN2 CBL 27 7:41P

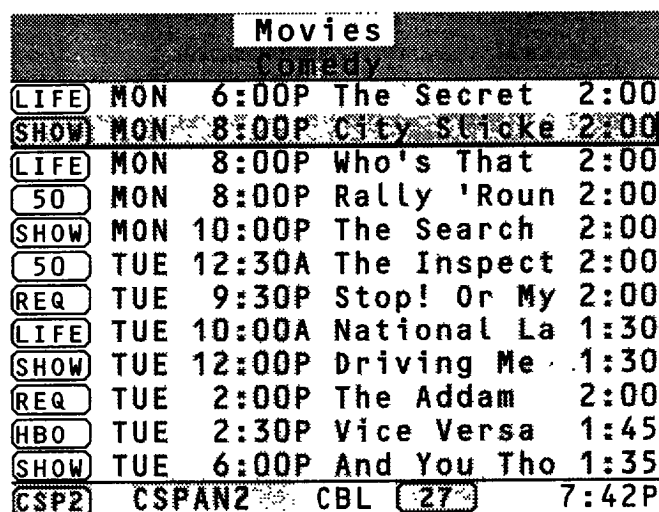

CSP2 CSPAN2 CBL 27 7:42P

USING STARSIGHT WITH THE UNIVERSAL REMOTE

Recording what you're watching: Current Recording

IMPORTANT: Your VCR must be turned off when you're not using it.

Also, be sure you have inserted a blank videotape in the VCR.

1. Press RECORD to see a Recording Pop-up. Notice that the yellow highlight bar is on "ONCE."
- If you're recording an event that might run over (for example, a baseball game), press ► on the Recording Pop-up to extend the end time of the recording in 5 minute increments.

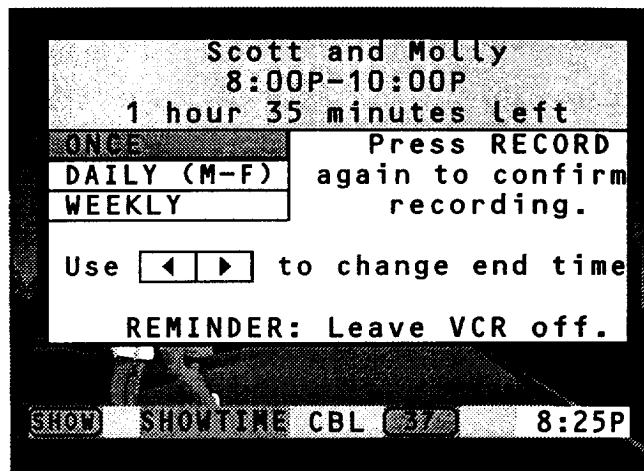

2. Press RECORD again to confirm your recording. StarSight will turn on your VCR and begin recording in a few seconds.

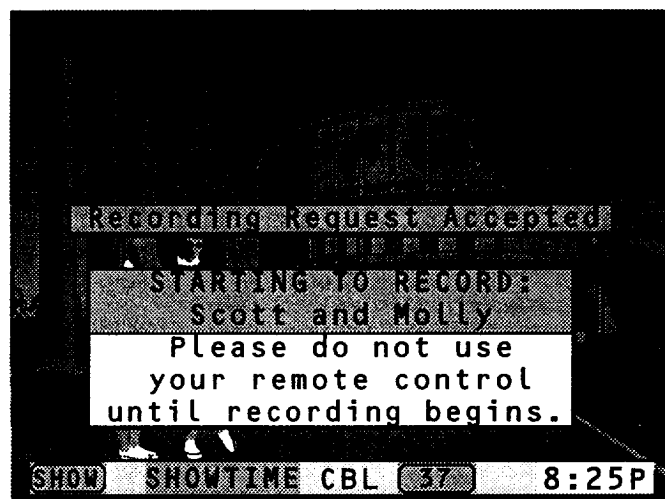

3. To cancel a recording in progress, press RECORD again and then press STAR to confirm.

YOU SHOULD ALSO KNOW...

- To turn your VCR on and off with the remote control, press the VCR button, followed by the POWER button. (See "Programming Your Remote" in the TV section of this guide.)
- Do not press VCR buttons while a StarSight recording is in progress.
- "ONCE" records the current program only, "DAILY" records the same program every day (M-F), and "WEEKLY" records it once a week.

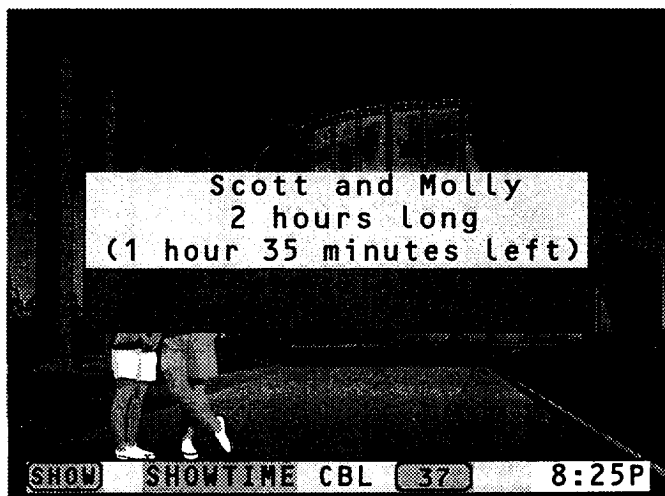

USING STARSIGHT WITH THE UNIVERSAL REMOTE

Scheduling a recording from StarSight guides: Future Recording

IMPORTANT: Your VCR must be turned off when you're not using it.

Also, be sure you have inserted a blank videotape in the VCR.

1. Press MENU/GUIDE to see the Grid Guide.
2. Press ◀, ▶, ↑, or ↓ to highlight a current or future program.
3. Press RECORD to see a Recording Pop-up for the selected program.
4. Press ↑ or ↓ to select ONCE, DAILY or WEEKLY.
5. Press RECORD again to confirm your recording. Just before your scheduled recording, StarSight turns on your VCR and begins recording.

6. To cancel a selected recording, highlight the program on the Grid Guide (it will be shown in red), press RECORD and then press STAR to confirm.

You can schedule recordings or cancel them from the Grid Guide, Channel Guide or Theme Guide.

YOU SHOULD ALSO KNOW...

- Selecting ONCE records the selected program.
- Selecting DAILY records a program every day (M-F).
- Selecting WEEKLY records a program once a week.
- You can extend the end time of a recording in 5 minute increments by pressing ▶ on the Recording Pop-up.
- For more information on recording, see "YOU SHOULD ALSO KNOW... Recording what you're watching: Current Recording."

S T A R S I G H T	
SEP	MON TUE WED THU FRI SAT SUN
7	8:00P
CSP2	U.S. Senate Coverage
CNN	Primenevs Larry King
26	Mathnet: Desp Math ... Who
SHOW	Scott and Molly
HBO	Bingo
DISC	All In A Day's Work
ESPN	Major League Baseball (L)
FAM	Batman
4	Blossom In the Best
DISN	Avonlea Casablanca
REQ	The Prince of Tides
CNN	CNN CBL 6 8:00P

S T A R S I G H T	
SEP	MON TUE WED THU FRI SAT SUN
7	8:30P 9:00P
CSP2	U.S. Senate Coverage
CNN	Primenevs Larry King
Larry King Live! 9:00P-10:00P	
ONCE	Press RECORD again to confirm recording
DAILY (M-F)	
WEEKLY	
Use ◀ ▶ to change end time	
REMINDER: Leave VCR off.	
CNN	CNN CBL 6 8:00P

S T A R S I G H T	
SEP	MON TUE WED THU FRI SAT SUN
7	8:30P
CSP2	U.S. Senate Coverage
CNN	Primenevs Larry King
26	Recording Request Accepted
SHOW	Scott and Molly
HBO	Bingo
DISC	All In A Day's Work
ESPN	Major League Baseball (L)
FAM	Batman
4	Blossom In the Best
DISN	Avonlea Casablanca
REQ	The Prince of Tides
CNN	CNN CBL 6 8:00P

USING STARSIGHT WITH THE UNIVERSAL REMOTE

Reviewing your schedule of individual recordings: Recordings List

StarSight keeps track of up to 25 scheduled recordings, including the four most recently completed.

1. Press TO DO to review your scheduled recordings.

RECORDINGS				
9	MON	10:00P	Northern Ex	
DISN	MON	11:00P	Gaslight	2:00
CNN	TUE	1:00A	Showbiz Tod	:30
DISN	TUE	4:00A	Casablanca	2:00
ESPN	TUE	6:30A	Getting Fit	:30
ESPN	WED	6:30A	Getting Fit	:30
5	WED	8:00P	Beverly Hil	1:00
ESPN	THU	6:30A	Getting Fit	:30
ESPN	FRI	6:30A	Getting Fit	:30
SHOW SHOWTIME CBL 37 10:05P				

2. Press ↑ or ↓ to highlight a recording.

RECORDINGS				
9	MON	10:00P	Northern Ex	:05
DISN	MON	11:00P	Gaslight	2:00
CNN	TUE	1:00A	Showbiz Tod	:30
DISN	TUE	4:00A	Casablanca	2:00
ESPN	TUE	6:30A	Getting Fit	:30
ESPN	WED	6:30A	Getting Fit	:30
5	WED	8:00P	Beverly Hil	1:00
ESPN	THU	6:30A	Getting Fit	:30
ESPN	FRI	6:30A	Getting Fit	:30
SHOW	FRI	8:00P	Scott and M	2:00
SHOW SHOWTIME CBL 37 10:05P				

3. Press STAR to see information about the program.

4. Press QUIT/SEQ to resume watching TV.

RECORDINGS				
Scott and Molly				
FRI 8:00P 2 hours				
A middle-aged couple discovers new sides to their relationship over a long, holiday weekend. Todd Blake, Kim Jones.				
*** (1988, PG-13) Movies: Comedy. Adult Situations, Adult Language.				
SHOW SHOWTIME CBL 37 10:05P				

YOU SHOULD ALSO KNOW...

- To cancel a recording, simply highlight the program and press RECORD, then STAR.
- If you see a question mark symbol on a scheduled recording, press MENU/GUIDE to see why there is a recording mismatch.
- Pressing ↑ repeatedly displays the last four completed recordings.

Programs with a white background are scheduled to be recorded; those with a gray background have already been recorded.

USING STARSIGHT WITH THE UNIVERSAL REMOTE

Reviewing daily or weekly series recordings: Series Recordings List

StarSight keeps track of up to five daily or weekly series recordings.

1. Press TO DO to review your scheduled recordings.

RECORDINGS

9	MON	10:00P	Northern Ex	2:00
DISN	MON	11:00P	Gaslight	2:00
CNN	TUE	1:00A	Showbiz Tod	:30
DISN	TUE	4:00A	Casablanca	2:00
ESPN	TUE	6:30A	Getting Fit	:30
ESPN	WED	6:30A	Getting Fit	:30
5	WED	8:00P	Beverly Hil	1:00
ESPN	THU	6:30A	Getting Fit	:30
ESPN	FRI	6:30A	Getting Fit	:30

2. Press TO DO again to see the Series Recordings list.

SHOW SHOWTIME CBL 37 10:05P

SERIES TO BE RECORDED

9	WK MON	10:00P	Northern	1:00
5	WK WED	8:00P	Beverly	1:00
ESPN	MTWThF	6:30A	Getting	:30

3. Press QUIT/SEQ to resume watching TV.

SHOW SHOWTIME CBL 37 10:07P

YOU SHOULD ALSO KNOW...

- To cancel a Series Recording, simply highlight the Series and press RECORD, then STAR. This also automatically cancels all individual recordings within that Series.

USING STARSIGHT WITH THE UNIVERSAL REMOTE

How to watch one channel while recording another: Watch and Record

if you have a Cable Box:

1. After recording begins, press TV/VCR SOURCE. You will see the TV SOURCE menu highlighted.

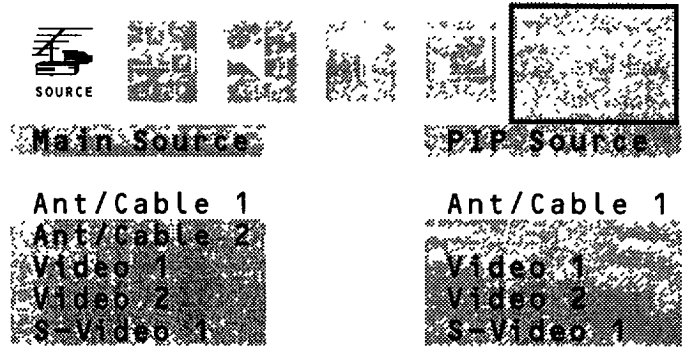

2. Press ↓ to highlight “Ant/Cable 2,” then press QUIT/SEQ. You can now watch any unscrambled channel.
3. Use CHANNEL/Day Up or Down to watch other channels. (Note: you will not be able to use StarSight functions while on the ANT/CABLE 2 source.)
4. To resume normal viewing once recording has been completed (and to resume using StarSight) press TV/VCR SOURCE to see the source menu. Then press ↑ to highlight “Ant/ Cable 1.” Press QUIT/SEQ.

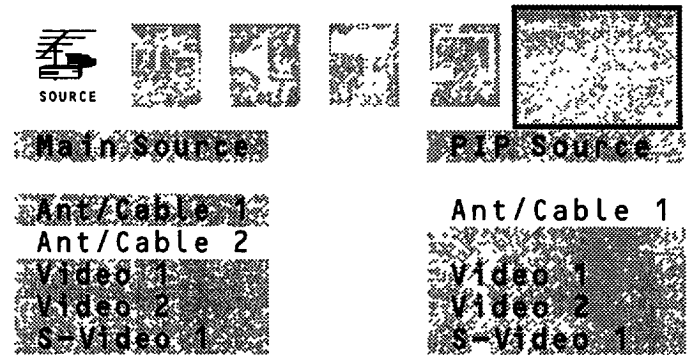

If you DO NOT have a Cable Box:

1. While you're recording a program, simply press CHANNEL/Day Up or Down to watch a different program.
2. For more information about the SOURCE menu, refer to the TV portion of this guide.

USING STARSIGHT WITH THE UNIVERSAL REMOTE

Selecting and deselecting channels

StarSight allows you to remove channels that you rarely or never watch. When a channel is removed, it will no longer appear in StarSight Guides, nor will it appear when you flip through channels. To increase the amount of information for individual programs that you watch, you should deselect channels that you seldom or never watch.

1. Press TO DO until you see the StarSight Setup menu. "Select Guide Channels" will be highlighted.

2. Press STAR to display your channel lineup.
3. Press ◀, ▶, ↑, or ↓ to highlight the channel you want to remove, and press STAR. The background color will change, indicating that the channel is deselected.

The PIP window shows a view of the highlighted channel.

4. If you change your mind, just highlight the channel again and press STAR. The background will return to green, and the channel will once again be selected.

NOTE: If you later add back a channel, you must wait 4-12 hours to collect program information for that channel. That channel now displays at the top of your channel list in the guides.

5. Press QUIT/SEQ twice to resume watching TV.

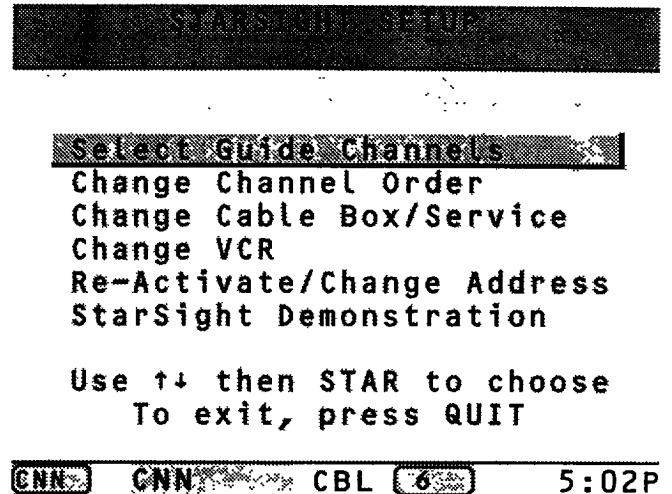

USING STARSIGHT WITH THE UNIVERSAL REMOTE

Changing the channel order

You can list your channels on the Grid Guide in any order you want. Your channels will also be in this order as you switch from channel to channel.

1. Press TO DO until you see the StarSight Setup menu.
2. Press ↓ to highlight "Change Channel Order," and press STAR to display your list of channels.
3. Press ◀, ▶, ↑, or ↓ to highlight the channel you want to move, and press STAR. The channel will move slightly to the left.

4. Press ◀, ▶, ↑, or ↓ to move the highlighted channel to the new location and press STAR to insert the channel in its new position.
5. Press QUIT/SEQ twice to resume watching TV.

YOU SHOULD ALSO KNOW...

- To reset your channels to the original order, press ↑ to highlight the RESET box at the top of the Change Channel Order screen and press STAR.
- To maximize show descriptions, you should place your most frequently-watched channels at the beginning of your list.

Select Guide Channels
~~Change Channel Order~~
 Change Cable Box/Service
 Change VCR
 Re-Activate/Change Address
 StarSight Demonstration

Use ↑ then STAR to choose
 To exit, press QUIT

CNN CNN CBL 6 5:02P

CHANGE CHANNEL ORDER
 Press STAR to place Channel
 RESET

5	NICK	MAX
MEU	TBS	
4	20	CNBC
AMC		TNN
CNN	22	SHOW
7	USA	REQ
HBO		DISN
9	26	REQ2
TNT	CSP2	
ESPN	2	DISC
MTV	BET	VH1

CHANGE CHANNEL ORDER
 Press STAR to move Channel
 RESET

AMC	NICK	MAX
MEU	TBS	
4	20	CNBC
5	TWC	TNN
CNN	22	SHOW
7	USA	REQ
HBO		DISN
9	26	REQ2
TNT	CSP2	
ESPN	2	DISC
MTV	BET	VH1

USING STARSIGHT WITH THE Z-TRAK REMOTE

Quick Reference Guide

This section of the guide discusses the use of StarSight with the Z-Trak trackball remote. Operation with the Z-Trak is different than with conventional remote controls. There are far fewer buttons, because the trackball is used to move an on-screen pointer through various menus. The following illustration shows the Z-Trak and its controls.

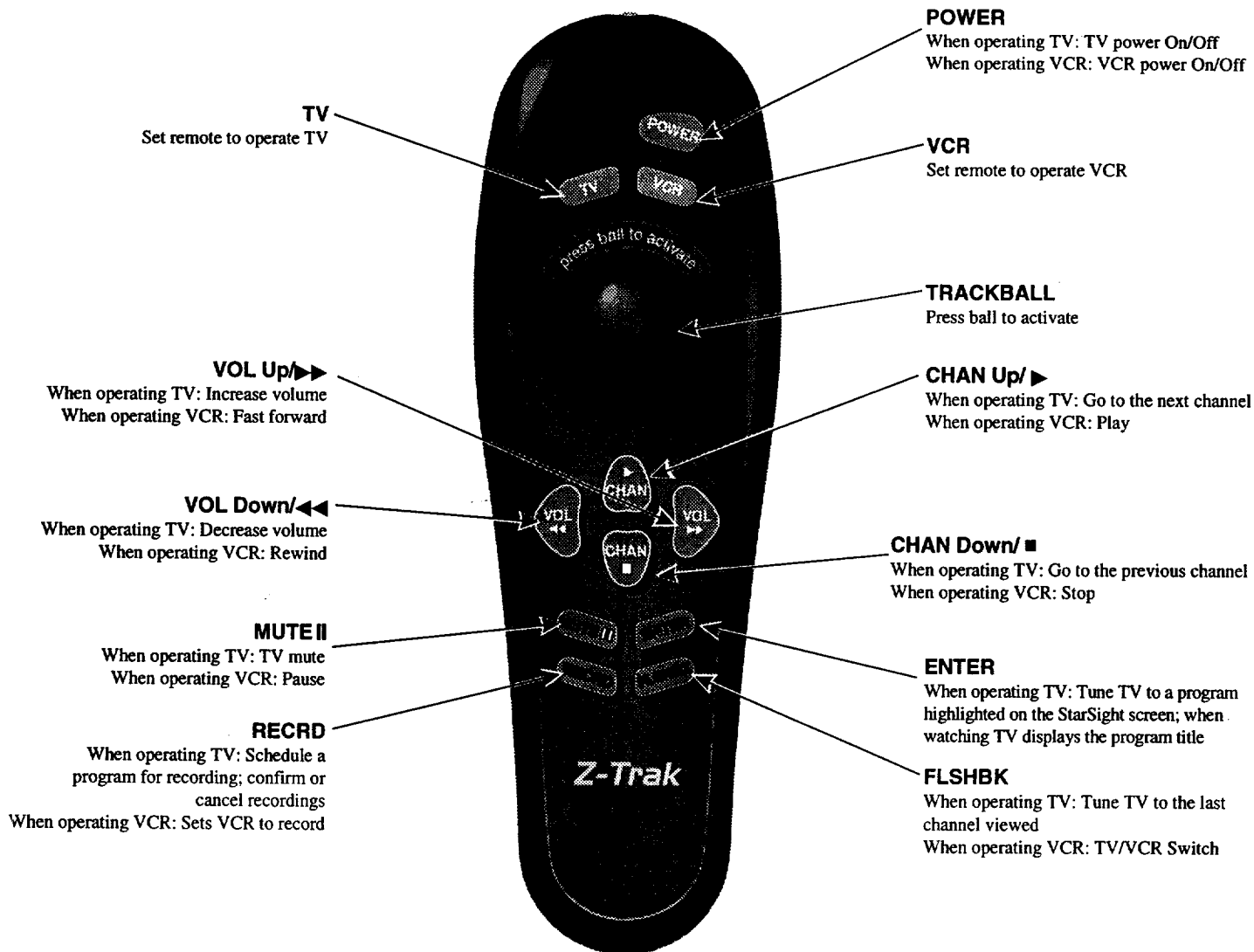

In the following sections, you will be exploring the various screen menus available in StarSight. As you do so, keep in mind the following guidelines (quite literally, "rules of thumb") for Z-Trak operation:

- To display the pointer, press the trackball.
- To highlight an option or make a selection, point to the desired option and press the trackball.
- To close a StarSight screen, point to the QUIT icon and press the trackball.
- To tune a channel, point to a channel icon and press the trackball. You can also simply highlight a program and press the ENTER button to tune that program.

- Many StarSight program guides have more than one screen full (one "page") of information. You can point to the "P↑" or "P↓" icons and press the trackball to flip through the pages. You can also move more slowly by moving the pointer to the top, bottom, or side edges of the screen and continuing to roll the ball in that direction.

Be sure that the pointer is *red*, indicating that you are in StarSight mode. If the pointer is blue, move the pointer to the left side of the TV screen, point to the TV icon and press the trackball.

USING STARSIGHT WITH THE Z-TRAK REMOTE

Getting started with the Z-Trak remote

1. Press the TV button on the top of the remote. This sets the remote's buttons for TV control, rather than VCR control.
2. Press the trackball. The pointer, a small square, appears in the middle of the screen.
3. You can move the pointer by rolling the trackball up, down, left, and right. Point to the left edge of the screen, a column of TV options appears. The icon at the top indicates which mode is active — StarSight or TV. A circle with a star, the StarSight logo, represents StarSight mode; a TV icon represents TV mode. You can switch between the two modes by locating the pointer on the StarSight or TV icon and pressing the trackball. The icon switches, and the pointer changes color. A *red* pointer indicates that you are in StarSight mode. A *blue* pointer indicates TV mode.

Set the mode to StarSight.

4. As you move the pointer around the screen, you will discover various menus. These menus are not visible on the screen simultaneously. Each Menu appears when you move the pointer on top of it. There are 2 different sets of menus—one for the StarSight mode and one for the TV mode. This section discusses the StarSight options. For information on the TV menus, see the TV portion of this guide.
5. Move the pointer to the top of the screen. At the top you'll see your StarSight icons:

SOURCE: When you press on this option, a selection screen appears which allows you to specify the video/audio source for your TV and the PIP. Simply point to the desired source and press. To return to normal TV viewing, point and press on "EXIT". For more information see the TV portion of the guide.

TO DO: When you press on this option, a list of scheduled recordings and series recordings appears.

THEME: When you press on this option, a list of theme categories appears.

GUIDE: When you press on this option, the Grid Guide and Channel Guide appear.

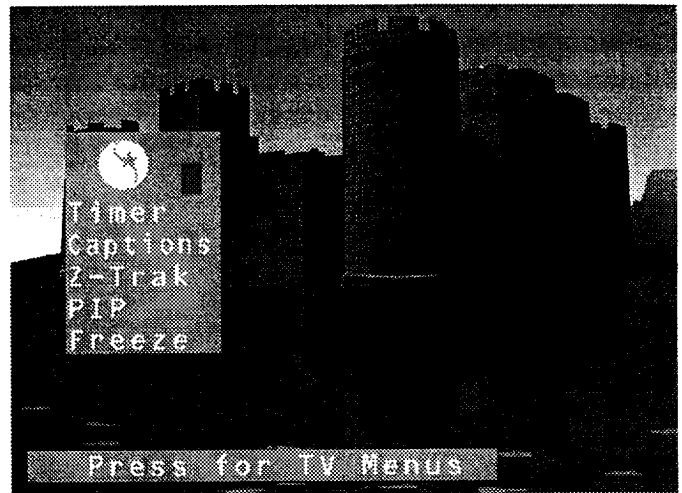

Continued on next page

USING STARSIGHT WITH THE Z-TRAK REMOTE

6. Move the pointer to the right of the screen. The channel icons appear:

All Chan: Gives you a complete listing of all channels. Point to a channel icon and press the trackball to tune. Or, point to the number pad and press the trackball to tune by channel number.

Tune: When browsing (see below), you can tune immediately to the show being described in the Pop-up, by pointing to "Tune" and pressing the trackball.

Browse ↑ and ↓: Allows you to get information about shows on different channels without actually changing to those channels. Place the pointer on or near an arrow and press the trackball.

Chan ↑ and ↓: Allows you to change channels up or down. Place the pointer on or near an arrow and press the trackball.

Info: Displays additional program information. Move the pointer to "Info" and press the trackball.

7. Move the pointer to the bottom of the screen. The volume control appears. To adjust the volume, point to the desired volume level on the slider bar and press the trackball. Point to "MUTE" and press the trackball to turn the sound off completely.
8. Move the pointer toward the middle of the screen to make the menu disappear.
9. Press the trackball to make the pointer disappear.

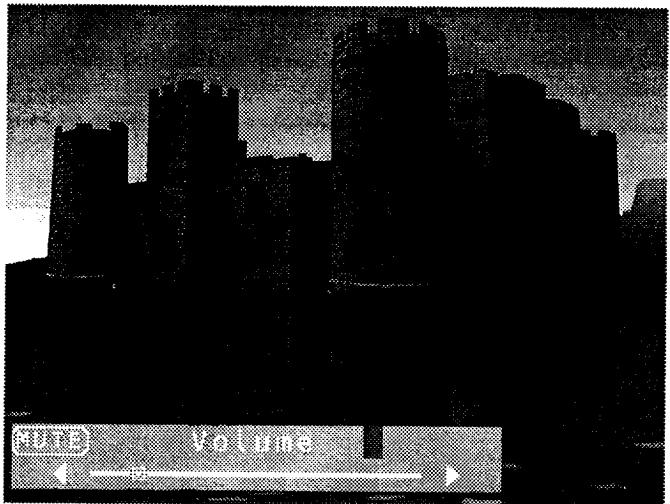
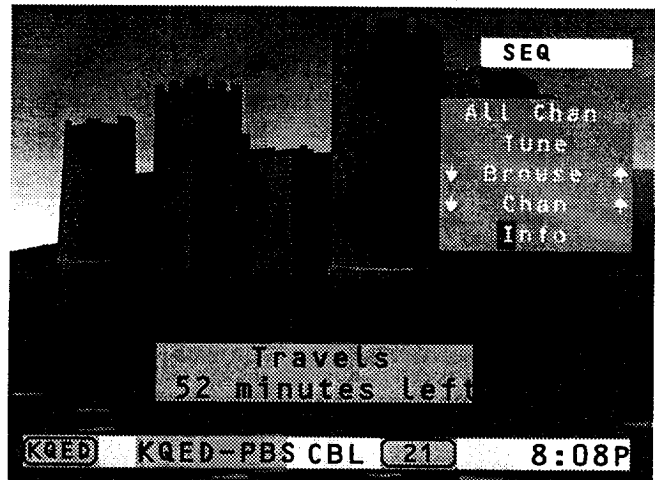

CHANGING YOUR EQUIPMENT SETUP

What you should do when you change your cable box or service or when you move

NOTE: THIS PROCEDURE REQUIRES THE USE OF THE UNIVERSAL REMOTE.

If you are changing your cable box, find the code(s) for your brand of new Cable Box on the "Cable Box Code" chart and write the code(s) here. _____

1. Press TO DO until you see the StarSight Setup menu.

2. Press the ↓ to highlight "Change Cable Box/Service."

or

Press the ↓ to highlight "Re-Activate/Change Address."

3. Press STAR.

4. Follow the on-screen instructions.

STARSTIGHT SETUP

Select Guide Channels |
Change Channel Order
Change Cable Box/Service
Change VCR
Re-Activate/Change Address
StarSight Demonstration

Use ↑↓ then STAR to choose
To exit, press QUIT

CNN CNN CBL 6 5:02P

STARSTIGHT SETUP

Select Guide Channels
Change Channel Order
Change Cable Box/Service |
Change VCR
Re-Activate/Change Address
StarSight Demonstration

Use ↑↓ then STAR to choose
To exit, press QUIT

CNN CNN CBL 6 5:02P

Before you proceed...

1. Please complete the StarSight Checklist in your Installation Guide.
2. Make sure you connect your TV to any other equipment according to the diagrams in your StarSight Installation Guide.
To continue, press ENTER.
To exit, press QUIT.

01

TROUBLESHOOTING

Before calling for service...

1. LEAVE YOUR CABLE BOX ON AT ALL TIMES.
2. LEAVE YOUR VCR OFF WHENEVER YOU ARE NOT WATCHING A VIDEOTAPE.
3. DO NOT PLUG YOUR TV INTO THE POWER PLUG ON THE BACK OF YOUR CABLE BOX.

Installation Problems

Problem	Try this
StarSight is not controlling my cable box and VCR.	Make sure the Remote Emitter is plugged into the Starsight Control Port on the back of your TV.
	Check the placement of your Remote Emitter(s)—the bulbs should be facing and a few inches in front of the front panel of your VCR and Cable Box.
	Make sure you have completed the equipment test with the proper code for your brand of equipment. See “Cable Box Codes” and “VCR Codes” charts.
My VCR turns off and on, but won't change channels.	If you have a Cable Box, your VCR does not need to change channels. (The Cable Box will change channels.)
	Try additional VCR codes until you pass the VCR tuning test. See “VCR Codes” chart. To test the code see “Changing Your Equipment Setup”.
	Your VCR must be capable of direct tuning, i.e. your VCR's original remote control must have a 10 digit number pad.
No Picture - “snow.”	Check the connections between your TV, VCR and/or Cable Box.
	Run “Auto Program” for your TV's “Ant/Cable 1” source. If your Setup is #4, then you should also Auto Program your “Ant/Cable 2” source. (See the TV portion of the guide.)
I do not get any channels above 13.	If you have a Cable Box, tune your TV to channel 3, or to the cable box output channel.
	Run “Auto Program” for your TV's “Ant/Cable 1” source. If your Setup is #4, then you should also Auto Program your “Ant/Cable 2” source. (See the TV portion of the guide.)
My TV turned off during Cable Box testing.	Make sure your TV is not plugged into the back of the Cable Box or into a power outlet that is controlled by a light switch. NOTE: LEAVE YOUR CABLE BOX ON AT ALL TIMES.
I can't make StarSight appear using the Universal remote control.	Press STAR to get your remote control to operate StarSight.
	Press TV/VCR Source and select “Ant/Cable 1” or StarSight if named.
	If you press a button on the remote control and its red light does not appear, then you need to change your remote control's batteries.
	Make sure you have activated StarSight! (See Installation Step 3, “Activate StarSight”.)
I can't make StarSight appear using the Z-Trak remote control.	Check that the on-screen pointer is <i>red</i> , indicating StarSight mode.
	If the pointer is <i>blue</i> , move it to the TV options menu on the left side of the screen. Point and press on the TV icon. The pointer will turn red and the StarSight logo will appear indicating StarSight mode.

Refer to the next page for Operation Problems.

TROUBLESHOOTING

Operation Problems

Problem	Try this
I've registered for StarSight but don't have any program data yet.	<ol style="list-style-type: none"> 1. Make sure your TV is turned off or tuned to PBS in order to receive information. It may take anywhere from 4-12 hours to initially get the full 7 days of information. For best results wait overnight. Check the PBS channel for good picture. 2. If you have a cable box, make sure the cable box automatically tunes to the PBS channel when TV is turned off.
The background color for the date and time are red.	Your TV lost power momentarily. StarSight will correct the time and date when your TV is turned off for a few minutes.
There are some blank spots in StarSight's guides.	StarSight may not have received all the program information. Your TV will collect program information whenever the TV is turned off.
StarSight's list of channels does not match those that appear on my TV.	Call the StarSight Help Desk at 1-800-628-STAR, or fax corrections directly to 1 (800) 229-9640.
The entire show did not record.	Make sure you have enough tape to record the whole program. StarSight records programs based upon the scheduled start and stop times. If a program may run overtime, you should extend the end time of your recording. (See the section "Current Recording" or "Future Recording".)
I have a Cable Box, and want to watch one program while recording another.	While a recording is in progress, change your source to "ANT/CABLE 2" to watch a different non-scrambled program.
I canceled the recordings of all episodes of a series, but new episodes for that same series are still being recorded.	You must cancel the whole series from the Series to be Recorded list. See the section "Series Recordings List".
A red question mark appears on a program title in the Recordings list.	The program information in the Recordings list does not match the program information in the Grid Guide. Position the highlight bar on the question mark and press MENU/GUIDE to see the program that will be recorded. If you don't want to record this program, press record to cancel the recording.
I can't control my VCR with my remote control.	You need to program your remote control for your particular brand of VCR. (See the sections on Remote Controls in the TV portion of this guide.)
I can't see the videotape when playing back on the VCR.	<ol style="list-style-type: none"> 1. Check the connections between your TV and VCR. 2. Make sure your TV is on channel 3 or 4. 3. If you still do not have a picture, try a different videotape that you know has a good picture.
The program wasn't recorded.	<ol style="list-style-type: none"> 1. YOUR VCR MUST BE LEFT OFF WHENEVER YOU ARE NOT WATCHING A VIDEOTAPE. Otherwise, a recording will not take place. Make sure you have a videotape with tape remaining. 2. Check the placement of your Remote Emitter. Has it fallen out of place? 3. Make sure you are confirming the recordings when you schedule a program for recording. 4. Check your Recordings List to see if you actually did schedule a recording for that specific program. 5. For a current recording, make sure you don't press any buttons until the recording has begun. 6. If you have changed your VCR, you will probably need to change the VCR code.
My picture turns to "snow" when recording begins.	To watch TV while recording, wait until recording has begun, then set the "TV/VCR" switch on your VCR to "TV." Or, on your Universal remote control, press the "VCR" button and then the "TV/VCR Source" button. (So the VCR is in "TV" mode.)
StarSight keeps playing a demonstration, and I want to stop it.	If you are running a Quick StarSight Demo, press any key. If you are running a Continuous Retail Demo (recommended for retailers only), wait for the message "To cancel this demonstration, press any button now," and press any button on the remote.

Refer to the previous page for Installation Problems.