

Operating Guide | Warranty

Model Numbers | C32V23, C36V23, C34W23 | Digital TVs

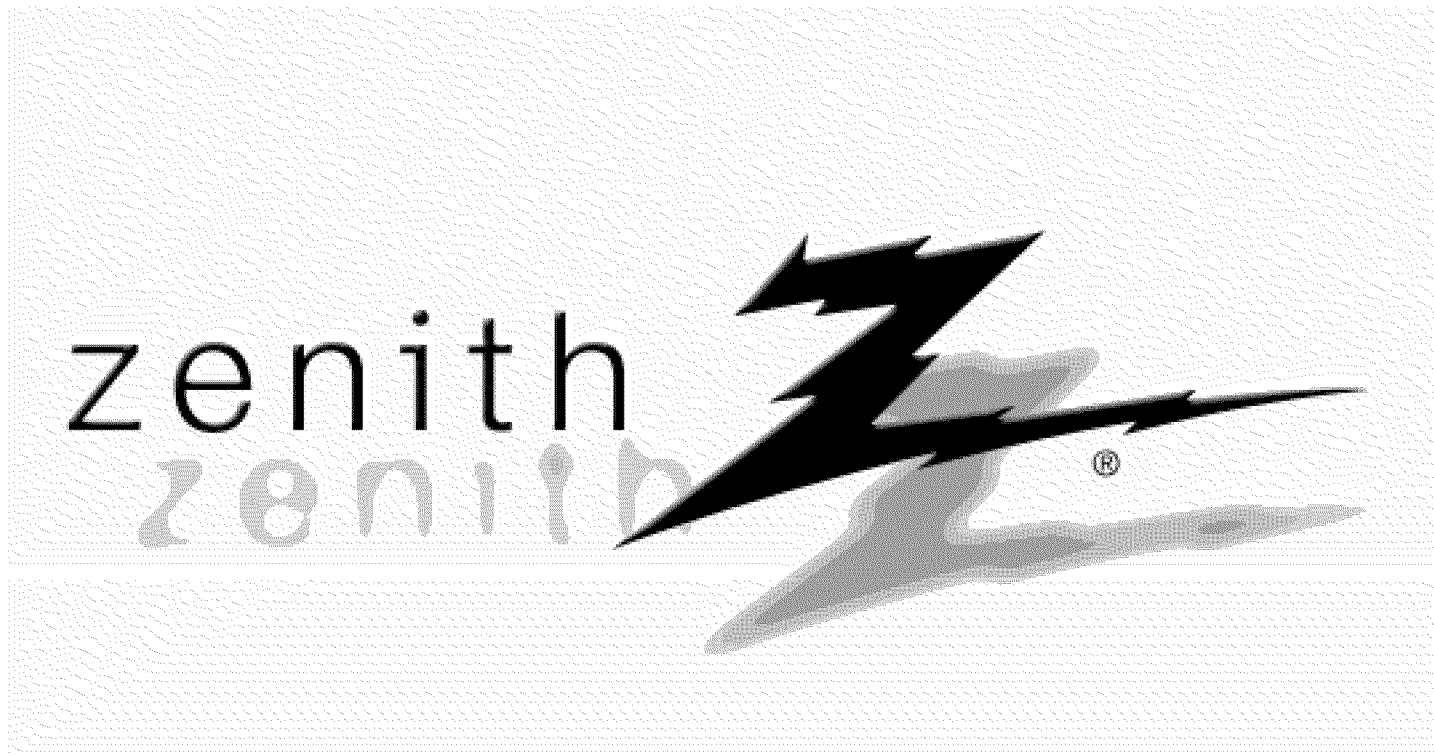

RECORD YOUR MODEL NUMBER

The model and serial number of your Entertainment Machine™ are located on the back of the TV cabinet. For your future convenience, we suggest that you record these numbers here:

Model No. _____
Serial No. _____



WARNING:

TO REDUCE THE RISK OF ELECTRIC SHOCK DO NOT REMOVE COVER (OR BACK). NO USER SERVICEABLE PARTS INSIDE. REFER SERVICING TO QUALIFIED SERVICE PERSONNEL.



The lightning flash with arrowhead symbol, within an equilateral triangle, is intended to alert the user to the presence of uninsulated “dangerous voltage” within the product’s enclosure that may be of sufficient magnitude to constitute a risk of electric shock to persons.



The exclamation point within an equilateral triangle is intended to alert the user to the presence of important operating and maintenance (servicing) instructions in the literature accompanying the appliance.

WARNING:

TO PREVENT FIRE OR SHOCK HAZARDS, DO NOT EXPOSE THIS PRODUCT TO RAIN OR MOISTURE.

POWER CORD POLARIZATION:

CAUTION: TO PREVENT ELECTRIC SHOCK, MATCH WIDE BLADE OF PLUG TO WIDE SLOT, FULLY INSERT.

ATTENTION: POUR ÉVITER LES CHOCS ÉLECTRIQUES, INTRODUIRE LA LAME LA PLUS LARGE DE LA FICHE DANS LA BORNE CORRESPONDANTE DE LA PRISE ET POUSSER JUSQU’AU FOND.

NOTE TO CABLE/TV INSTALLER:

This reminder is provided to call the cable TV system installer’s attention to Article 820-40 of the National Electric Code (U.S.A.). The code provides guidelines for proper grounding and, in particular, specifies that the cable ground shall be connected to the grounding system of the building, as close to the point of the cable entry as practical.

REGULATORY INFORMATION:

This equipment has been tested and found to comply with the limits for a Class B digital device, pursuant to Part 15 of the FCC Rules. These limits are designed to provide reasonable protection against harmful interference when the equipment is operated in a residential installation. This equipment generates, uses and can radiate radio frequency energy and, if not installed and used in accordance with the instruction manual, may cause harmful interference to radio communications. However, there is no guarantee that interference will not occur in a particular installation. If this equipment does cause harmful interference to radio or television reception, which can be determined by turning the equipment off and on, the user is encouraged to try to correct the interference by one or more of the following measures:

- Reorient or relocate the receiving antenna.
- Increase the separation between the equipment and receiver.
- Connect the equipment into an outlet on a circuit different from that to which the receiver is connected.
- Consult the dealer or an experienced radio/TV technician for help.

CAUTION:

Do not attempt to modify this product in any way without written authorization from Zenith Electronics Corporation. Unauthorized modification could void the user’s authority to operate this product.

COMPLIANCE:

The responsible party for this product’s compliance is:
Zenith Electronics Corporation, 2000 Millbrook Drive, Lincolnshire, IL 60069, USA • Phone: 1-847-941-8000.

IMPORTANT SAFETY INSTRUCTIONS

Important safeguards for you and your new product

Your product has been manufactured and tested with your safety in mind. However, improper use can result in potential electrical shock or fire hazards. To avoid defeating the safeguards that have been built into your new product, please read and observe the following safety points when installing and using your new product, and save them for future reference.

Observing the simple precautions discussed in this operating guide can help you get many years of enjoyment and safe operation that are built into your new product.

This product complies with all applicable U.S. Federal safety requirements, and those of the Canadian Standards Association.

1. Read Instructions

All the safety and operating instructions should be read before the product is operated.

2. Follow Instructions

All operating and use instructions should be followed.

3. Retain Instructions

The safety and operating instructions should be retained for future reference.

4. Heed Warnings

All warnings on the product and in the operating instructions should be adhered to.

5. Cleaning

Unplug this product from the wall outlet before cleaning. Do not use liquid cleaners or aerosol cleaners. Use a damp cloth for cleaning.

6. Water and Moisture

Do not use this product near water for example, near a bath tub, wash bowl, kitchen sink, or laundry tub, in a wet basement, or near a swimming pool.

7. Accessories, Carts, and Stands

Do not place this product on a slippery or tilted surface, or on an unstable cart, stand, tripod, bracket, or table. The product may slide or fall, causing serious injury to a child or adult, and serious damage to the product. Use only with a cart, stand, tripod, bracket, or table recommended by the manufacturer, or sold with the product. Any mounting of the product should follow the manufacturer's instructions, and should use a mounting accessory recommended by the manufacturer.

8. Transporting Product

A product and cart combination should be moved with care. Quick stops, excessive force, and uneven surfaces may cause the product and cart combination to overturn.



PORTABLE CART WARNING

9. Attachments

Do not use attachments not recommended by the product manufacturer as they may cause hazards.

10. Ventilation

Slots and openings in the cabinet are provided for ventilation and to ensure reliable operation of the product and to protect it from overheating, and these openings must not be blocked or covered. The openings should never be blocked by placing the product on a bed, sofa, rug, or other similar surface. This product should not be placed in a built-in installation such as a bookcase or rack unless proper ventilation is provided or the manufacturer's instructions have been adhered to.

11. Power Sources

This product should be operated only from the type of power source indicated on the marking label. If you are not sure of the type of power supply to your home, consult your product dealer or local power company. For products intended to operate from battery power, or other sources, refer to the operating instructions.

12. Power Cord Polarization

This product is equipped with a polarized alternating - current power plug (a plug having one blade wider than the other). This plug will fit into the power outlet only one way. This is a safety feature. If you are unable to insert the plug fully into the outlet, try reversing the plug. If the plug should still fail to fit, contact your electrician to replace your obsolete outlet. Do not defeat the safety purpose of the polarized plug.

13. Power Cord Protection

Power-supply cords should be routed so that they are not likely to be walked on or pinched by items placed upon or against them, paying particular attention to cords at plugs, convenience receptacles, and the point where they exit from the product.

(Continued on next page)

IMPORTANT SAFETY INSTRUCTIONS

(Continued from previous page)

14. Outdoor Antenna Grounding

If an outside antenna or cable system is connected to the product, be sure the antenna or cable system is grounded so as to provide some protection against voltage surges and built-up static charges. Article 810 of the National Electrical Code (U.S.A.), ANSI/ NFPA 70 provides information with regard to proper grounding of the mast and supporting structure, grounding of the lead-in wire to an antenna discharge unit, size of grounding conductors, location of antenna-discharge unit, connection to grounding electrodes, and requirements for the grounding electrode.

Example of Grounding According to National Electrical Code Instructions

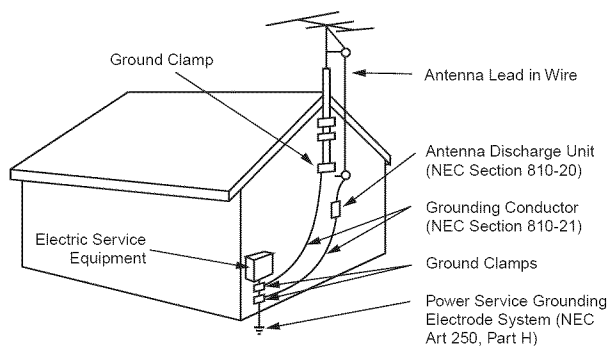

NEC - National Electrical Code

15. Lightning

For added protection for this product (receiver) during a lightning storm, or when it is left unattended and unused for long periods of time, unplug it from the wall outlet and disconnect the antenna or cable system. This will prevent damage to the product due to lightning and power-line surges.

16. Power Lines

An outside antenna system should not be located in the vicinity of overhead power lines or other electric light or power circuits, or where it can fall into such power lines or circuits. When installing an outside antenna system, extreme care should be taken to keep from touching such power lines or circuits as contact with them might be fatal.

17. Overloading

Do not overload wall outlets and extension cords as this can result in a risk of fire or electric shock.

18. Object and Liquid Entry

Never push objects of any kind into this product through openings as they may touch dangerous voltage points or

short-out parts that could result in a fire or electric shock. Never spill liquid of any kind on the product.

19. Servicing

Do not attempt to service this product yourself as opening or removing covers may expose you to dangerous voltage or other hazards. Refer all servicing to qualified service personnel.

20. Damage Requiring Service

Unplug this product from the wall outlet and refer servicing to qualified service personnel under the following conditions:

- If the power-supply cord or plug is damaged.
- If liquid has been spilled, or objects have fallen into the product.
- If the product has been exposed to rain or water.
- If the product does not operate normally by following the operating instructions. Adjust only those controls that are covered by the operating instructions as an improper adjustment of other controls may result in damage and will often require extensive work by a qualified technician to restore the product to its normal operation.
- If the product has been dropped or the cabinet has been damaged.
- If the product exhibits a distinct change in performance.

21. Replacement Parts

When replacement parts are required, be sure the service technician has used replacement parts specified by the manufacturer or have the same characteristics as the original part. Unauthorized substitutions may result in fire, electric shock, or other hazards.

22. Safety Check

Upon completion of any service or repairs to this product, ask the service technician to perform safety checks to determine that the product is in proper operating condition.

23. Wall or Ceiling Mounting

The product should be mounted to a wall or ceiling only as recommended by the manufacturer. The product may slide or fall, causing serious injury to a child or adult, and serious damage to the product.

24. Heat

The product should be situated away from heat sources such as radiators, heat registers, stoves, or other products (including amplifiers) that produce heat.

Table of Contents

Refer to the information below to hook up external equipment and set up the features on your TV. As a aid to installing and setting up your TV, see the Setup Checklist on the next page...

Step 1. Hook up external equipment and antenna or cable service wires to the TV. Install batteries in the remote control. After all connections have been made, plug your TV into standard household power, see pages 7 thru 17.

Step 2. Go to page 18 to use EZ Scan. (Search for and memorize all the channels available in your area.)

Step 3. Set up all other TV options see pages listed below.

Safety Warnings	2
Important Safety Information	3 - 4
Table of Contents	5

Step 1. Hook Up TV

Setup Checklist (what you need to do to get the TV working)	6
Connection Panel Jacks Overview	7

Equipment Connection Options

Antenna, Install batteries in remote	8
Cable Service, Install batteries in remote	9
Antenna with VCR, Install batteries in remote control	10
Cable Service with VCR, Install batteries in remote control	11
S-VHS VCR, Install batteries in remote control	12
DVD Component Video Hook up	13
High-Definition Hook up	14
Audio/Video Signal Output	15
Digital Audio Output	16
Front Panel Controls/Inputs	17

Step 2. Reception Setup and Channel Search

EZ Scan, Select: Antenna, DTV, or Cable service and let the channel search memorize channels in your area	18
Remote Control Key Functions in TV mode	19
On-Screen Menu Operation with Remote	20
Source Selection Options	21
On-Screen Menus/Displays Overview	22 - 23
Other Functions and On-Screen Displays	24

Step 3. Customize the TV's Features

Setup Menu (Start with page 18, EZ Scan)

Channel Edit	25
DTV Signal	26
Tilt	27
Channel Labels	28
Input Source	29

Video Menu

EZ Picture: (Custom, Normal, Digital Preset, Night Time, Movie,

Weak Signal, Video Game, Sports), Contrast, Brightness, Color, Tint, Sharpness, Color Temp, Z-View

Audio Menu

Audio Mode: (Mono, Stereo, SAP), EZ SoundRite, EZ Sound: (Custom, Normal, Stadium, News, Music, Theater) Balance, Treble, Bass, Speakers, Front Surround.

Time Menu

Clock	32
Off Timer	33
On Timer	33
Sleep Timer	34

Special Menu

Aspect Ratio	35
Analog Caption	36
Language	37
EZ Demo (On-screen menus/displays overview)	38

Lock (Parental Control Menu)

39 - 40 - 41
Restricts viewer programming.

Remote Control Programming

Set up remote to operate other devices	42
Mode Sound Switch Setup	43
Verify Mode's 3-Digit Code	44
AutoSearch	45
Programming Product Brand Codes	46 - 47
Remote Modes Key Functions	48
Maintenance	49
Troubleshooting	50 - 51 - 52
Glossary	53
Notes	54 - 55
Zenith Warranty	Back Cover

Note: Design and specifications are subject to change without prior notice.

Dolby Digital®

Manufactured under license from Dolby Laboratories.

"Dolby" and the double-D symbol are trademarks of Dolby Laboratories.

Confidential Unpublished Works. ©1992 - 1997 Dolby Laboratories, Inc. All rights reserved.

Setup and Operation Checklist

(See page 5 for available connection and operational setup options.)

1. Unpack TV and all accessories.
2. Connect your TV to input sources: antenna and all video source equipment.
See pages 7 - 14.
3. Connect TV output to all external video and audio equipment
see pages 7, 15, 16.
4. Install batteries in remote control.
See any page 8 through 14.
5. Plug TV and source equipment into power outlets.
See pages 8 through 14.
6. Turn TV on.
See pages 17 (Front Panel) and 19 (Remote Control).
7. Choose on screen menu language.
See page 37. (English is selected.)
8. Use EZ Scan* to search for all channels in your area.
See page 18.
9. Turn video source equipment on.
10. Select viewing source for TV.
See pages 21 and 29
11. Fine-tune source image and sound to personal preference or as required by source.
See pages 30, 31, and 35.
12. Additional features Setup
See Table of Contents.

***EZ Scan/Channel Search Notes -Available Channels/Active Channels/DTV Channels**

EZ Scan finds channels which have a signal present and are actively being broadcast. Some broadcasters do not provide or send or broadcast a signal continuously. As a result, some DTV channels may not be found with EZ Scan. If you know that there is a DTV channel that was not found by EZ Scan, run EZ Scan again; when the DTV channel is actually sending out a program.

"Source" Connection Panel Overview

Use this page for reference to connect: High Definition equipment, Standard Definition equipment, DVD Player, and VHS equipment.

To hook up source equipment, see below and also refer to the Table of Contents on page 5; shows pages to go to for equipment hookup options. Also, see the front connections panel source's hookup options on page 17.

After you have finished hooking up your source equipment, go to page 18 and use EZ Scan to search for and find all the available channels in your area.

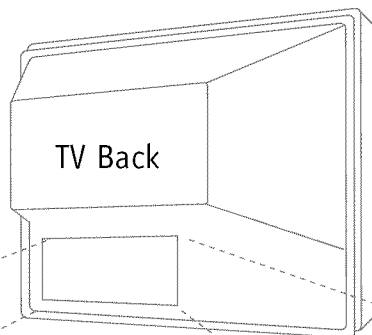

ANTENNA/CABLE 1
ANTENNA 2
Use Antenna/Cable 1 to hookup an antenna or cable system.
See pages 8, 9, 10, 11, 12.

To hookup both digital and analog sources, use ANTENNA/CABLE 1 and ANTENNA 2.
Refer to EZ Scan on page 18, to see digital and analog hookup options.

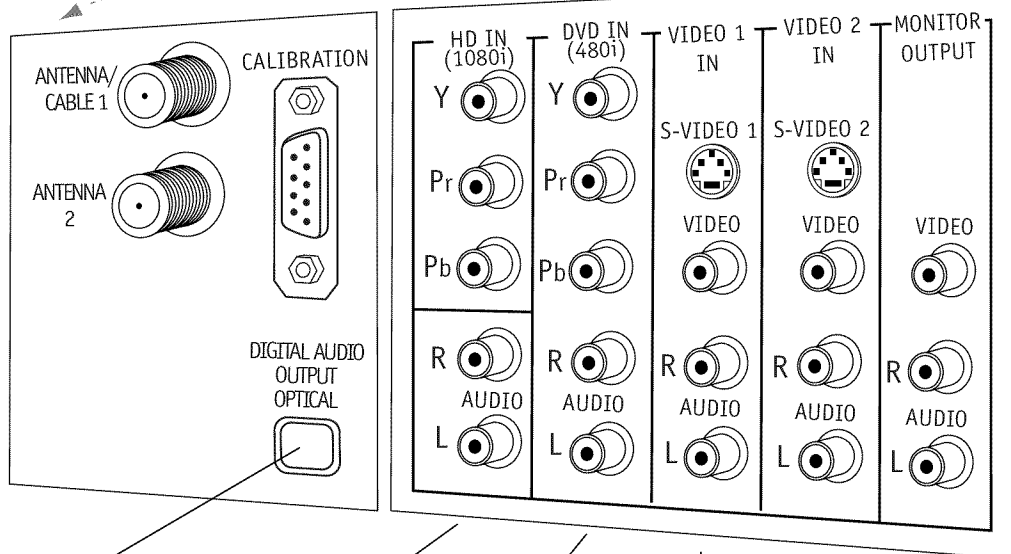

DIGITAL AUDIO OPTICAL OUTPUT
Connects to external audio equipment like a stereo system.
See page 16.

HD IN 1080i
Connect high-definition component video equipment here.
-EDTV Set top Box, 1080i
-HDTV Set top Box, 1080i
See page 14.

DVD IN 480i
Connect standard component video equipment or DVD player here.
-DVD Player, 480i
-SDTV Set top Box, 480i
See page 13.

VIDEO 1 IN VIDEO 2 IN
Connect your Audio/Video or S-Video equipment to these jacks.
See pages 10, 11, 12.

VIDEO / R - L AUDIO OUT
Use these output jacks to connect external audio/video equipment.
See page 15.

Important Antenna/Cable-Digital/Analog Connections Note:

If you use both digital and analog equipment to receive your TV channels, use both Antenna/Cable 1 and Antenna 2 jacks. Refer to EZ Scan on page 18, to see digital and analog hookup options.

Hook Up an Off-Air Antenna

Connect an off-air antenna

- 1** Locate the Antenna/Cable 1 jack on the back of your TV.
- 2** Connect the antenna wire that runs from the wall directly to this jack, according to one of the diagrams to the right.
- 3** Remove the back of the remote and put in two "AAA" batteries.

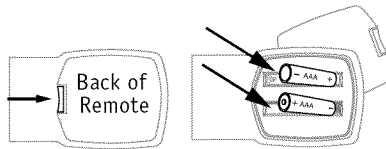

- 4** Plug in your TV. Your TV is designed to operate on standard household current, 120-volt 60 Hertz AC. Do not plug it into an outlet controlled by a switch. Do not attempt to operate it on DC power.

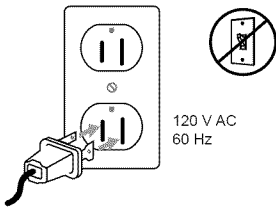

If you have a 75 ohm RF cable, then you don't need any adapters!



A 300 to 75 ohm adapter is not included with the TV.

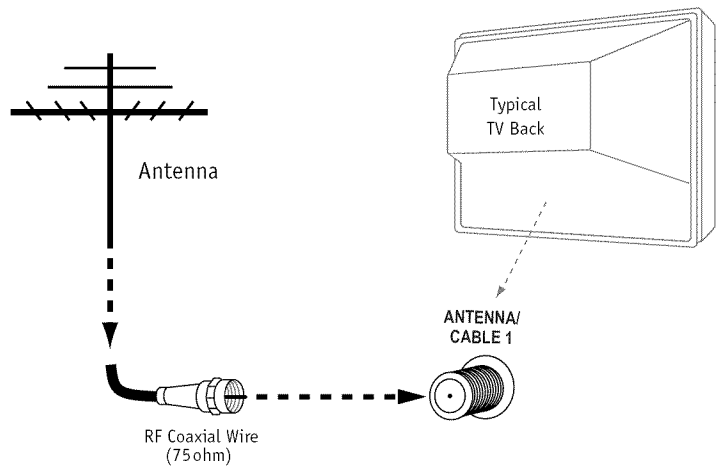
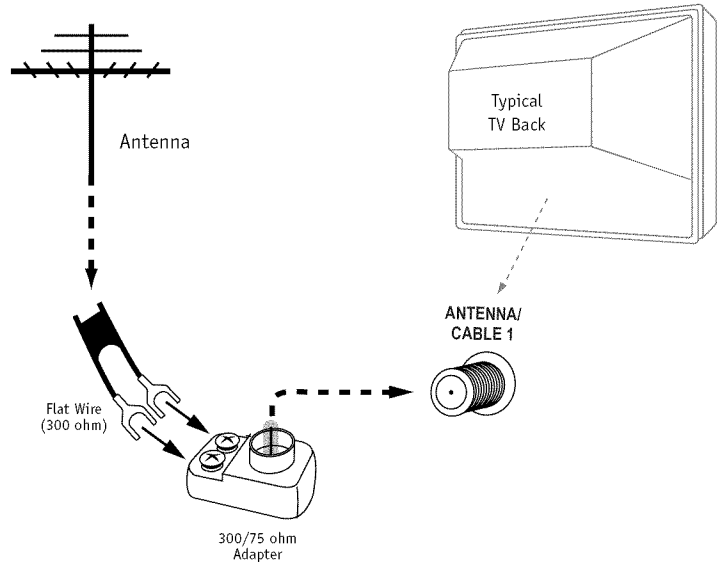

Mini glossary

- 75 OHM RF CABLE** The wire that comes from an off-air antenna or cable service provider. Each end looks like a hex shaped nut with a wire sticking through the middle, and it screws onto the threaded antenna/cable jack on the back of your TV.
- 300 TO 75 OHM ADAPTER** A small device that connects a two-wire 300 ohm antenna to a 75 ohm RF jack. They are usually about an inch long with two screws on one end and a round opening with a wire sticking out on the other end.

Hook Up Cable Service (CATV)

Connect cable service to your Entertainment Machine

- 1 Locate the Antenna/Cable jack on the back of the TV.
- 2 Connect the cable service wire that runs from the wall or cable box directly to this jack, according to one of the diagrams to the right.
- 3 Remove the back of the remote and put in two "AAA" batteries.

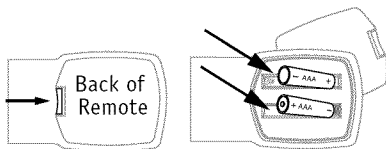

- 4 Plug in your TV. Your TV is designed to operate on standard household current, 120-volt 60 Hertz AC. Do not plug it into an outlet controlled by a switch. Do not attempt to operate it on DC power.

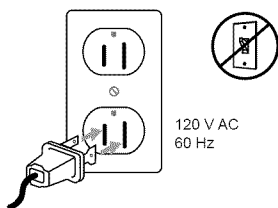

If you're using a cable box, leave the TV on channel 3 or 4 and use your cable box to change channels.



If you're using a cable box, EZ Scan might only find the channel your cable service is on (usually channel 3 or 4). Don't worry, that's all you need!

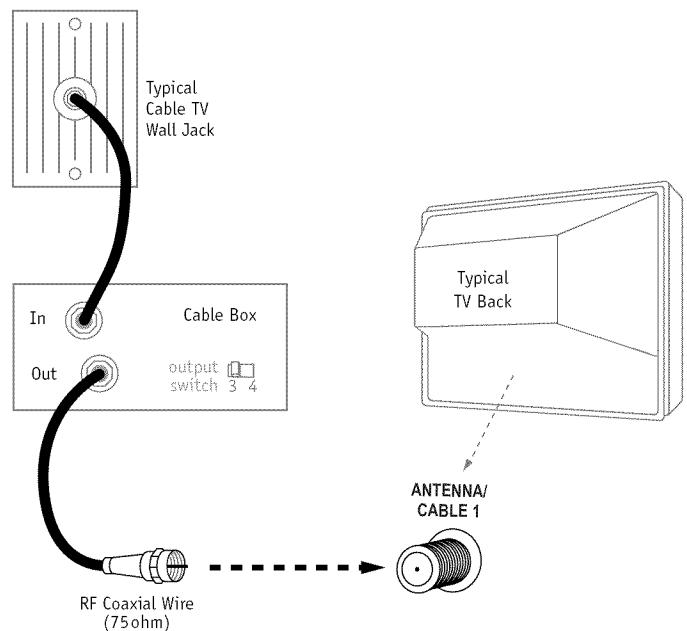
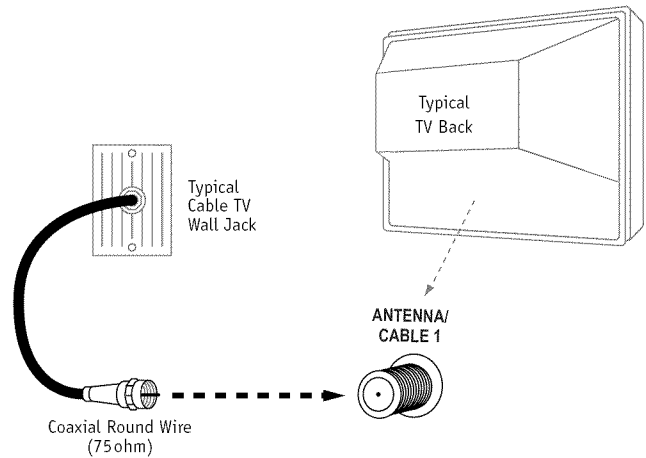

Hook Up a VCR

Connect a VCR to your TV

- 1** Locate the Antenna In jack on the back of the VCR.
- 2** Connect the wire that runs from the antenna, according to the diagram to the right. Make any other connections as necessary.
- 3** Remove the back of the remote and put in two "AAA" batteries.

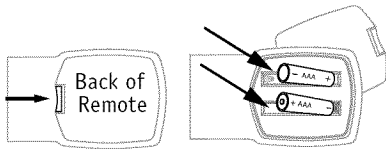

- 4** Plug in your TV. Your TV is designed to operate on standard household current, 120-volt 60 Hertz AC. Do not plug it into an outlet controlled by a switch. Do not attempt to operate it on DC power.

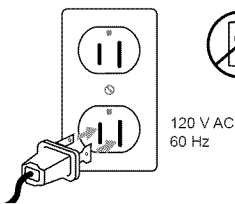

 No adapters or A/V cables are included with the TV. See your Zenith dealer to purchase any adapters or cables.

 Without A/V cables, most VCRs will not play videocassettes in stereo sound.

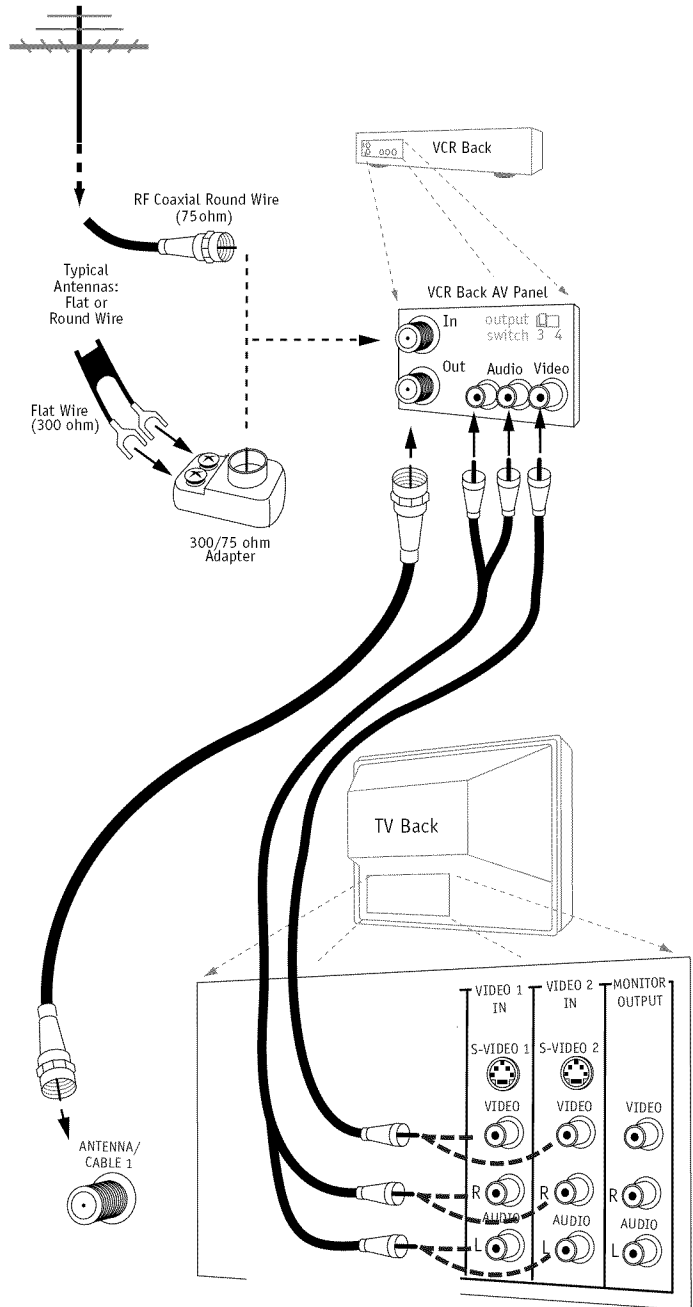

Connect your VCR to the Video 1 or Video 2 set of input jacks

Hook Up Cable Service (CATV) and VCR

Connect Cable service and a VCR to the TV

- 1** Locate the Antenna/Cable In jack on the back of the VCR.
- 2** Connect the cable service wire that runs from the wall, according to one of the diagrams to the right. Make any other connections necessary for your setup.
- 3** Remove the back of the remote and put in two "AAA" batteries.

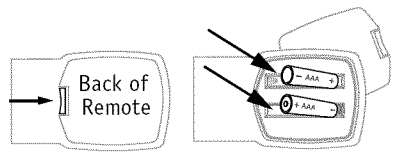

- 4** Plug in your TV. Your TV is designed to operate on standard household current, 120-volt 60 Hertz AC. Do not plug it into an outlet controlled by a switch. Do not attempt to operate it on DC power.

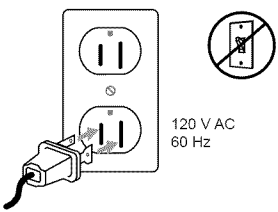

 Tune both the VCR and the television to channel 3 or 4 (cable box output channel) and use the cable box to change channels.

 No A/V cables are included with your TV. Without A/V cable hookups, most VCRs will not play videocassettes in stereo sound.

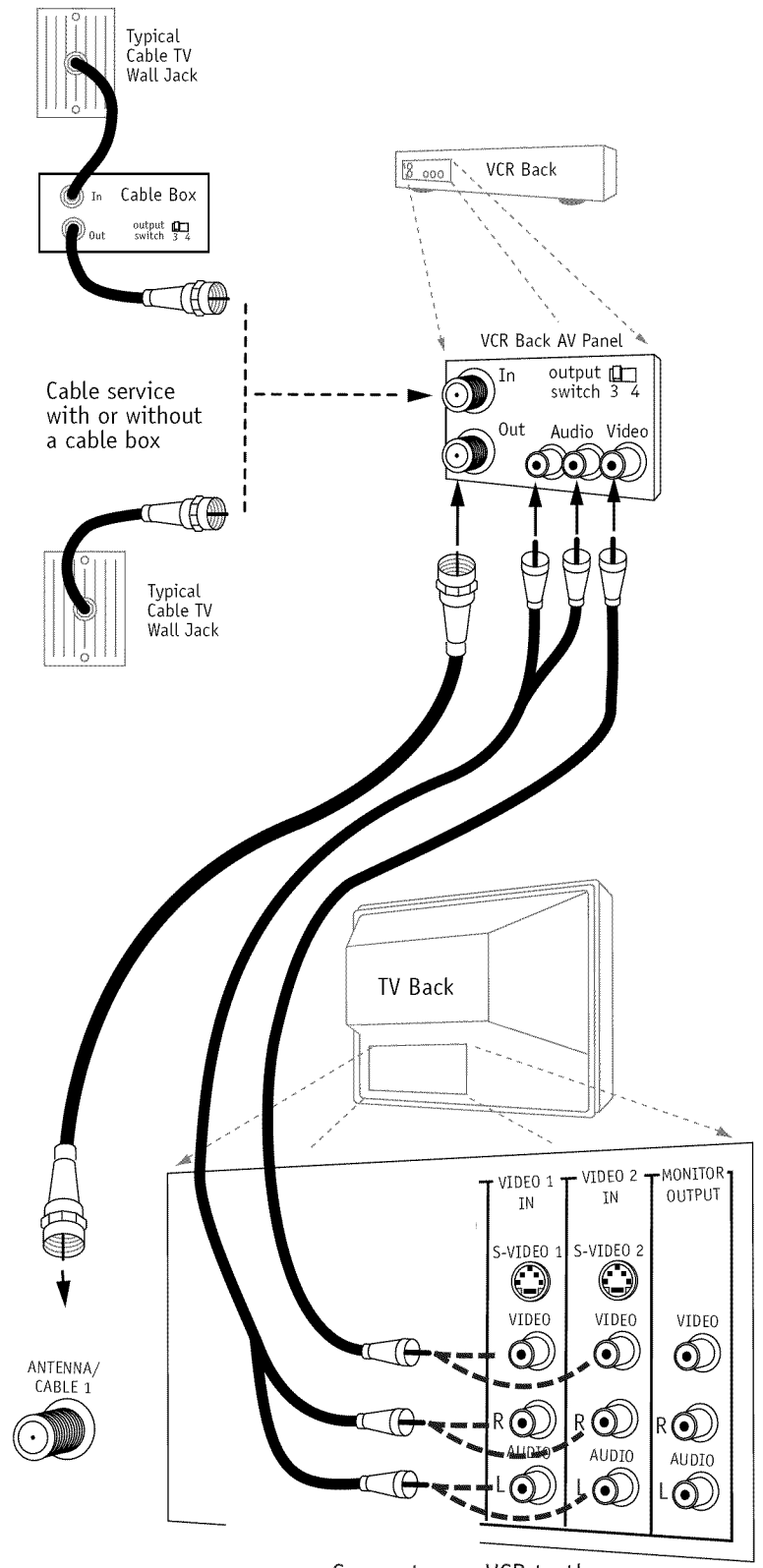

Connect your VCR to the Video 1 or Video 2 set of input jacks

Hook Up S-VHS VCR

Your Zenith TV may be connected to a Super-VHS VCR through the S-Video Input located on the front or rear source connection panels on your TV

1 Hook up your S-VHS VCR to your Zenith TV according to the diagram shown at the right.

2 Remove the back of the remote and put in two "AAA" batteries.

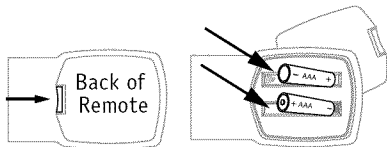

3 Plug in your TV. Your TV is designed to operate on standard household current, 120-volt 60 Hertz AC. Do not plug it into an outlet controlled by a switch. Do not attempt to operate it on DC power.

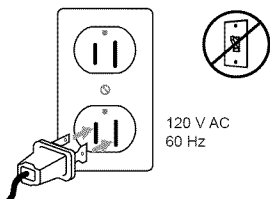

4 On the remote, press SOURCE repeatedly until "Video1 or Video2" is displayed. Or use the Source menu to choose the Video1 or Video2 input the equipment is connected to.

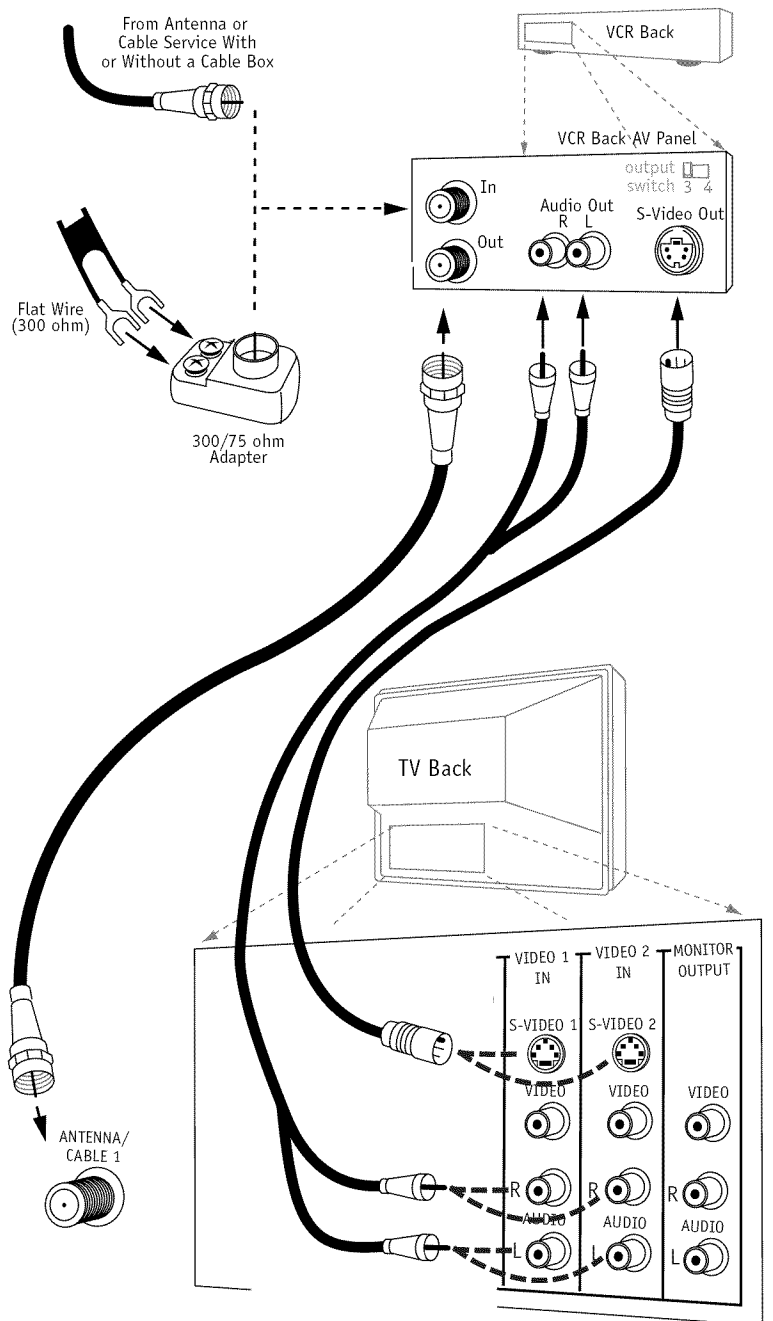

Connect your S-Video VCR to the S-Video 1 or S-Video 2 set of input jacks

Hook Up Component Video Equipment



The DVD IN Input jacks will only accept an interlaced signal. Switch your DVD player or set-top box to interlaced.

Connecting component video DVD equipment

DVD IN (480 Interlaced only)

Connect standard component video equipment or a DVD player here.

DVD Player, 480i

SDTV Set top Box, 480i

1 Make the connections as indicated. (Appearance of components may vary from those in the illustrations.)

2 Remove the back of the remote and put in two "AAA" batteries.

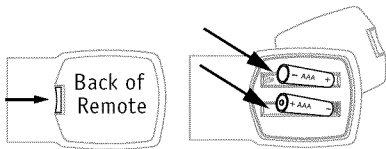

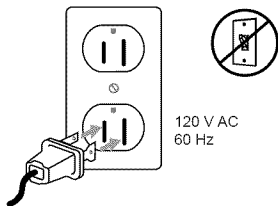

3 Plug in your TV. Your TV is designed to operate on standard household current, 120-volt 60 Hertz AC. Do not plug it into an outlet controlled by a switch. Do not attempt to operate it on DC power.



4 Press POWER to turn TV on.

5 On the remote, press SOURCE repeatedly until "DVD IN" is displayed. Or use the Source menu to choose DVD IN.

 Component video jacks are sometimes labeled with Cr, Cb, or Pb, Pr. In this case, connect B to B and the R to R. The "Y" jack is usually labeled "Y", connect Y to Y.

 DVD IN input does not accept progressive (480p/720p) or interlaced (1080i) video formats.

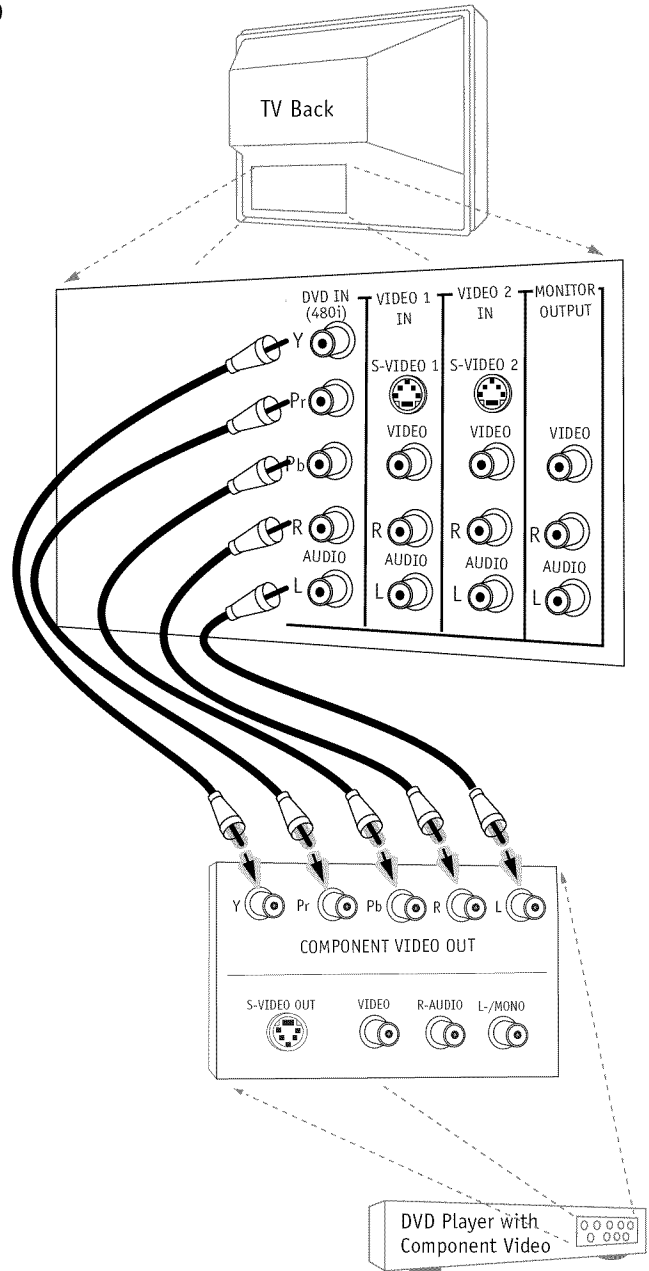

Hook Up HD Equipment



The HD IN Input jacks will only accept a 1080i interlaced signal. Switch your set-top box to interlaced.

Connecting high-definition equipment

HD IN (1080i Interlaced only)

Connect high-definition component video equipment here.

HDTV Set top Box, 1080i

1 Make the HD connections as indicated. (Appearance of components may vary from those in the illustrations.)

2 Remove the back of the remote and put in two "AAA" batteries.

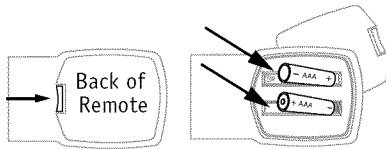

3 Plug in your TV. Your TV is designed to operate on standard household current, 120-volt 60 Hertz AC. Do not plug it into an outlet controlled by a switch. Do not attempt to operate it on DC power.

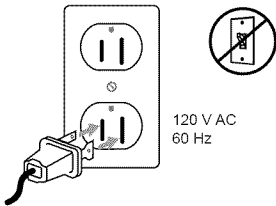

4 Press POWER to turn TV on.

5 On the remote, press SOURCE repeatedly until "HD-In" is displayed. Or use the Source menu to choose HD-In.



HD IN input does not accept progressive (480p/720p) or interlaced (480i) video formats.

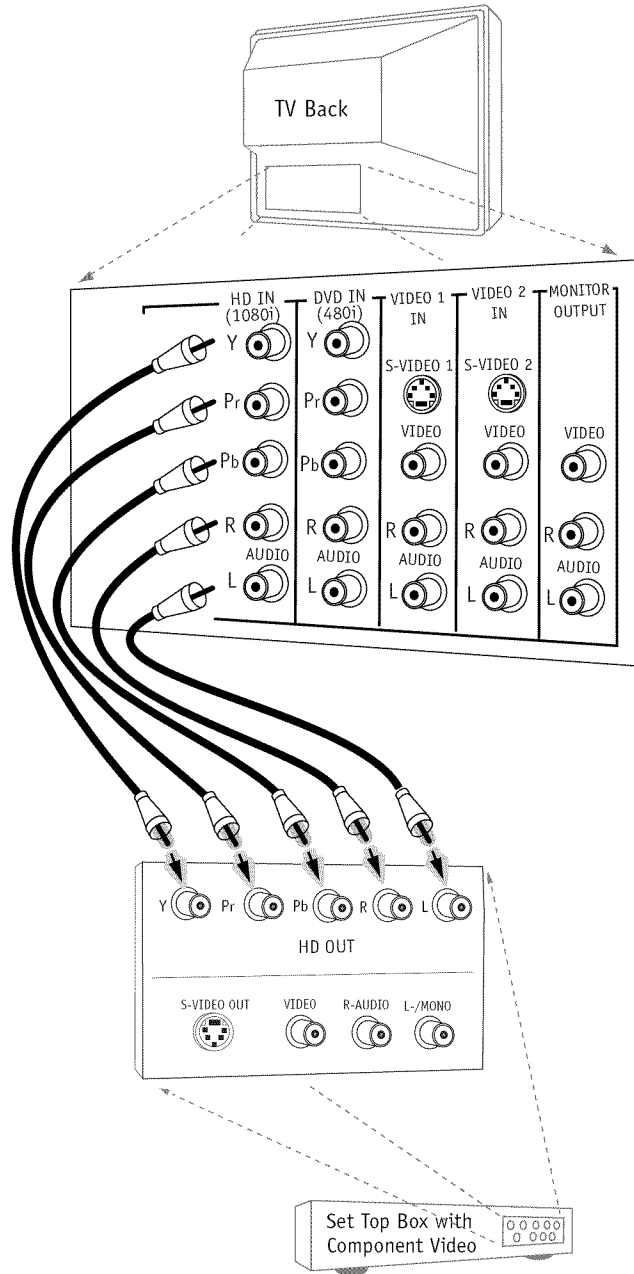

Audio/Video Signal Output

Output to Audio/Video devices

Make the Audio/Video Output connections as indicated. (Appearance of devices may vary from those in the illustrations.)

1

Video Output

Use the Video Out jack to connect to an external video device.

2

Audio Output

Use the Left and Right Audio Out jacks to connect an external amplifier and speakers. (Refer to the Audio Menu on page 31 for instructions on how to turn the TV's internal speakers off and on.)

3

Select Audio/Video Input on the external device to see the image and hear the sound from the TV.



If you are watching a *DIGITAL CHANNEL* or the source connected to the *HD-IN* or *DVD-IN* jacks, *MONITOR OUTPUT* is not available.

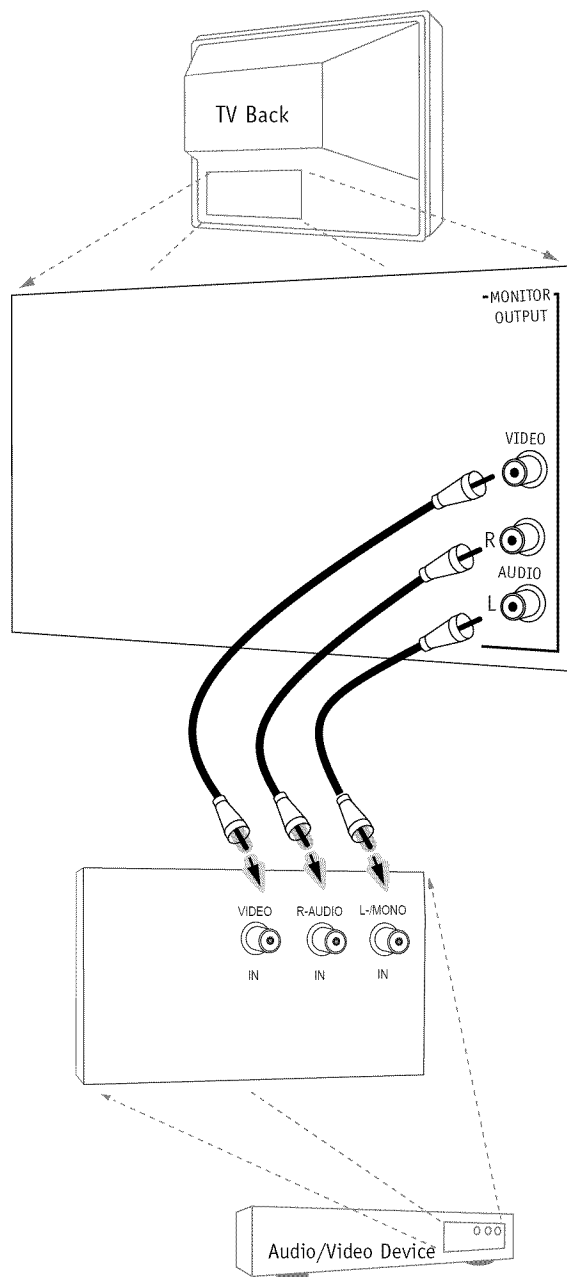

Digital Audio Output

Send the TV's audio out to external audio equipment (stereo system) via the Digital Audio Optical Output port

- 1** Connect one end of an optical cable to the TV Digital Audio Optical Output port.
- 2** Connect the other end of the optical cable to the digital audio optical input on the audio equipment.
- 3** See the external audio equipment instruction manual for operation.



Caution: Do not look into the optical output port. Looking at the laser beam may damage your vision.

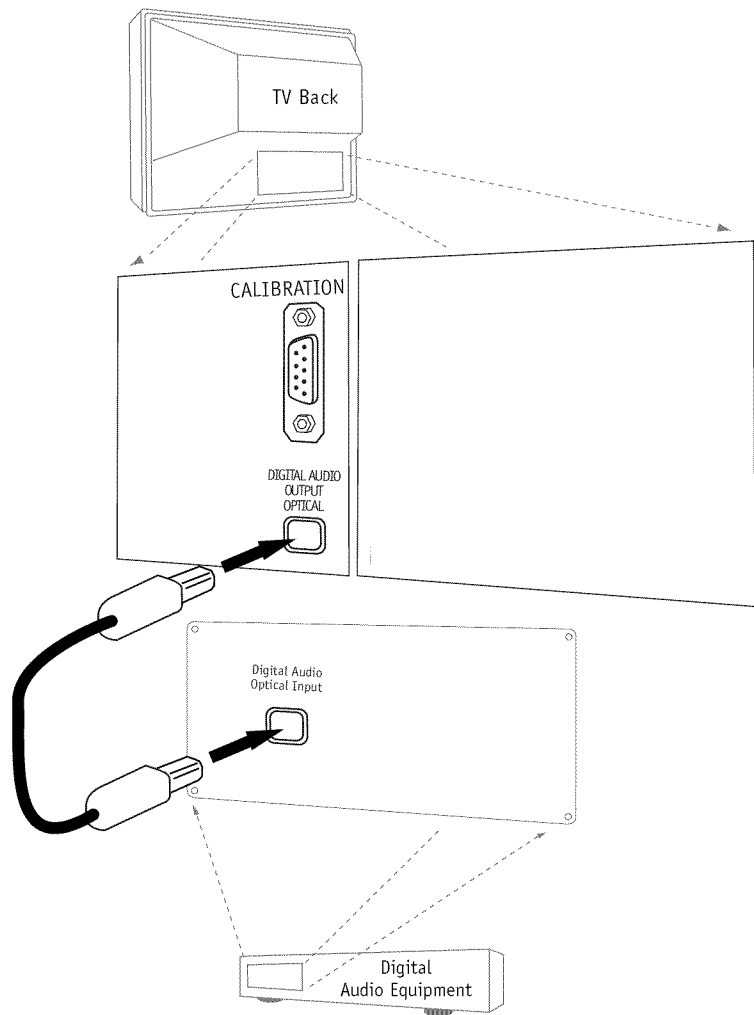

Front-Side Panel Controls/Inputs

Using the front/side panel to operate the TV's basic features and to make temporary connections

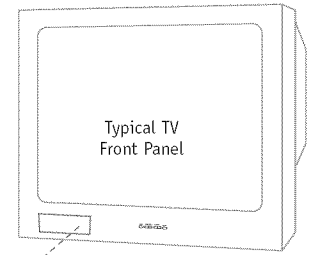

Menu Operation

- 1** Press MENU to place menus on screen.
- 2** Use Channel Up/Down to select menu option.
- 3** Use Volume Left/Right to adjust menu option.
- 4** Use MENU to remove menus from screen.

TV Operation

- 1** Press POWER to turn TV on and off.
- 2** Use the CHANNEL Up/Down buttons to select the next higher/lower channel number
- 3** Use the VOLUME Left/Right buttons to adjust the sound level quieter or louder to your preference.

Temporary Connections

- 1** Connect your video equipment like a Camcorder to the Front Video input jacks.
- 2** On the remote control, use Source to choose Front Video, or use the Source menu to choose the Front Video input source.



S-video / Video
Connects the video signals from external equipment.

Left/Right Audio
Used for stereo sound from external equipment.

C34W23 Side Control Panel

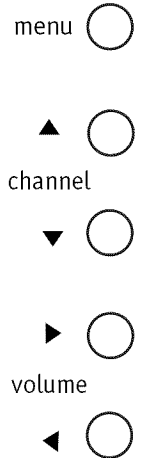

C32V23/C36V23 Front Control Panel

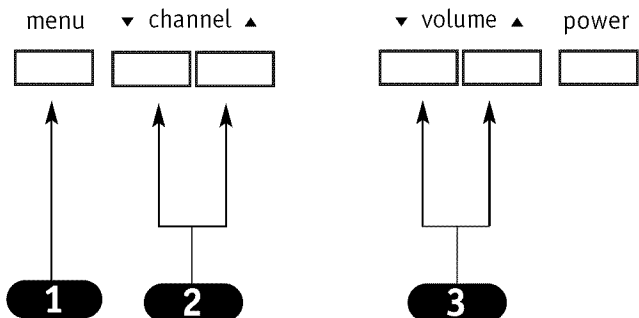

Typical Front Panel Controls
Note: Side controls operate the same as the front controls shown above.

EZ Scan (Channel Search)

Use EZ Scan to automatically find active channels and store them in the TV's memory

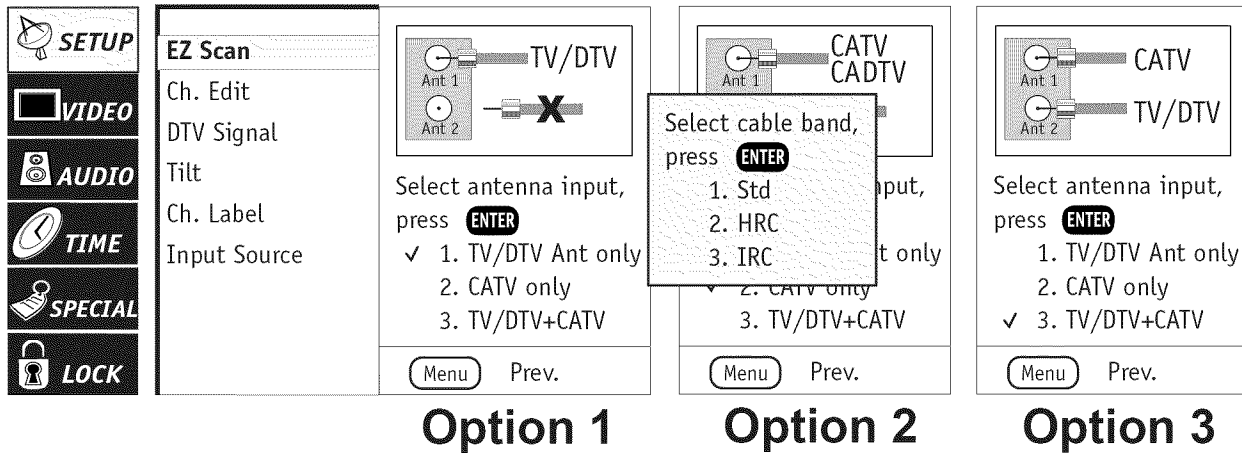

- 1** Press MENU, (if not selected, use the Up/Down arrow to choose Setup Menu,) then press ENTER or the right arrow button.
- 2** Using the Up or Down arrow on the remote control, select EZ Scan on your screen, then press ENTER or the right arrow button.
- 3** Using the Up or Down arrow, select option 1, 2, or 3. (Based on your connection(s) to Antenna/Cable 1-2.)
- 4** Press ENTER to begin the channel search.
Note: Allow EZ Scan to complete the channel search cycle for TV, CABLE*, DTV, etc.
- 5** When the channel search is complete, press MENU repeatedly until all menus are removed, or press QUIT.



EZ Scan finds active channels being received by the TV tuner.



Cable will not work unless you subscribe to a cable service.



Run EZ Scan again after any Antenna/Cable connection changes.

Mini glossary

- TV The antenna device receiving the program signal sent over-the-air.
 DTV Digital TV programming sent over-the-air.
 CATV Your EZ Scan selection, if you subscribe to a cable service.
 CADTV Your EZ Scan selection, if you subscribe to a digital cable service.

*Cable Service Band Note: Select Std=Standard, HRC=HRC Band, or IRC=IRC Band.

For further band information, contact your cable service provider.

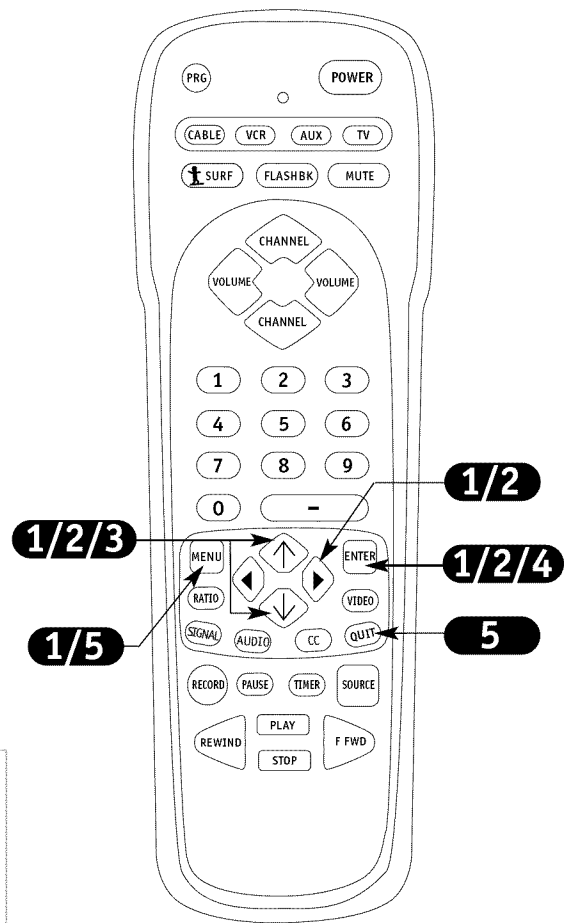

TV Mode Remote Key Functions

Note: Pressing TV puts remote into TV operating mode

A quick list of the keys on your remote and what they do in TV mode, see page 48 for remote key functions in all programmable modes...

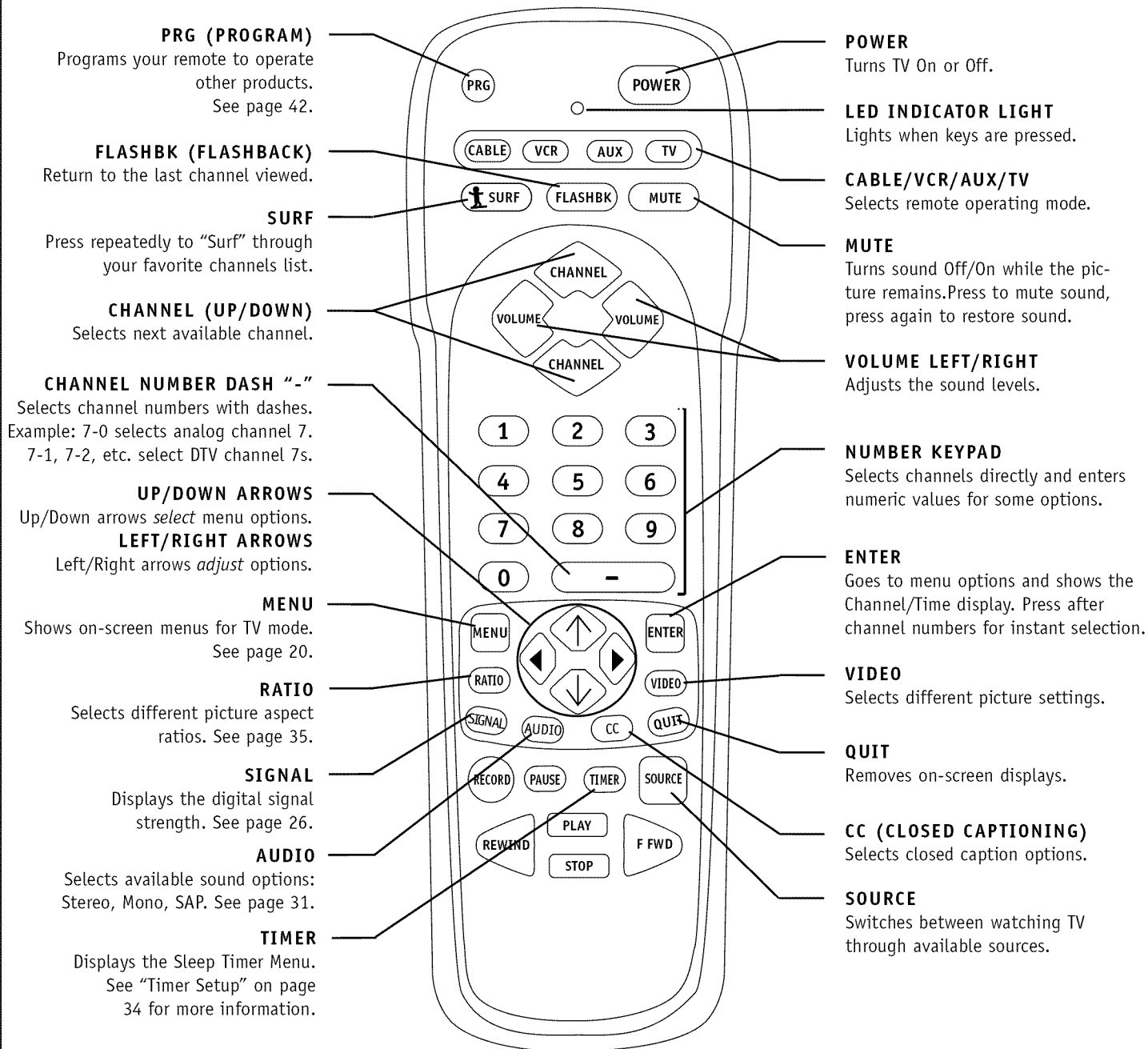

Keys dedicated to VCR functions will still operate your VCR while the remote is in TV mode.

remote control part number
MBR4286
 (P124-00240)

On-Screen Menu Operation

Use the remote to access the on-screen menus

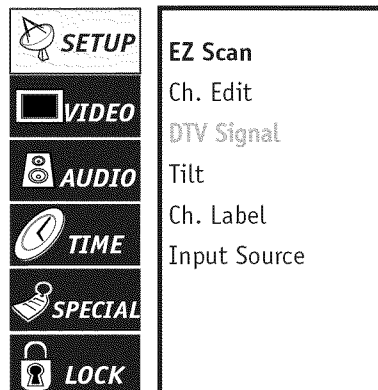

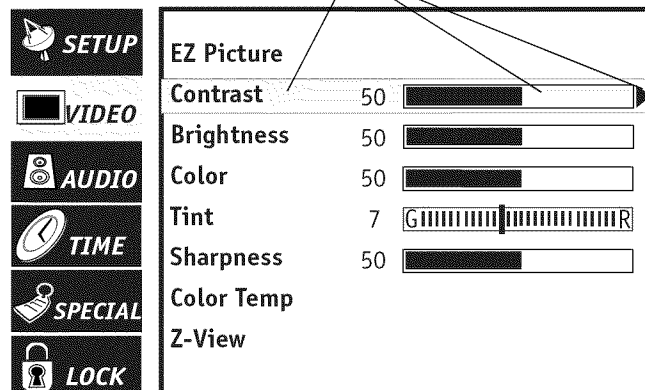

Main TV Features Menu



Video Menu

- 1** Press MENU on the remote control. Use the Up or Down directional arrow to "select" or highlight the name of one of the six main menus on your screen like the VIDEO menu, then press ENTER.
- 2** Use the Up or Down directional arrow to highlight an option like the CONTRAST adjustment bar, then press the Right arrow. You can select other menu options like COLOR TEMP using the UP or DOWN directional arrows.
- 3** Once the option is selected, in this case CONTRAST, use the RIGHT or LEFT directional arrow to adjust the setting; the larger the number the more contrast, the lower the number, the less contrast in the picture. Note: Some menu options use a checkmark to indicate setting, see page 22.
- 4** You can adjust the other menu options using the above procedure or if you are done adjusting the menu option settings:
 - a. Press MENU repeatedly to go back to the main menu.
 - b. Press QUIT to remove the menus from the TV screen.

 Additional instructions are usually included on the bottom of the menu indicating which remote keys to use to move to the right, move to the left, or return to the previous menu, etc.

 Use the number keypad to enter numerical values when required.

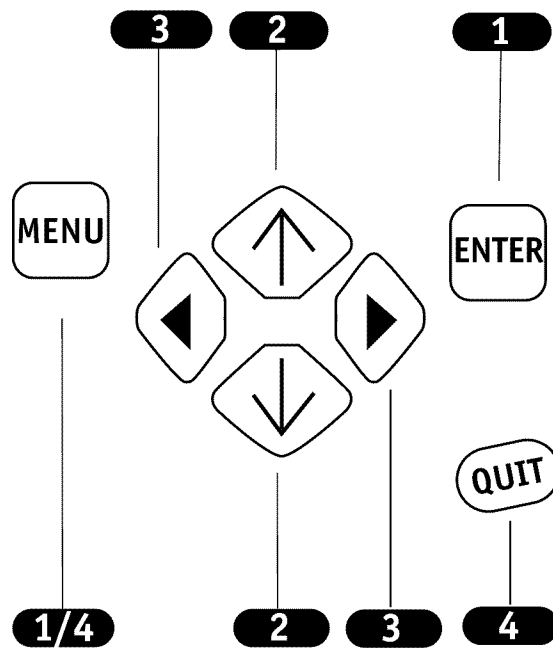

Mini glossary

MENU	On-screen displays used to set up and operate TV features.
ENTER	Action key used to make changes on the menus.
UP/DOWN	Menu UP or DOWN directional arrows used to "select" or highlight and choose menu options.
LEFT/RIGHT	Menu LEFT or RIGHT directional arrows used to "adjust" some menu settings.
QUIT	Exits menus and removes on-screen displays.

Input Source Selection Options

Choose the connected source you want to see and hear on your TV

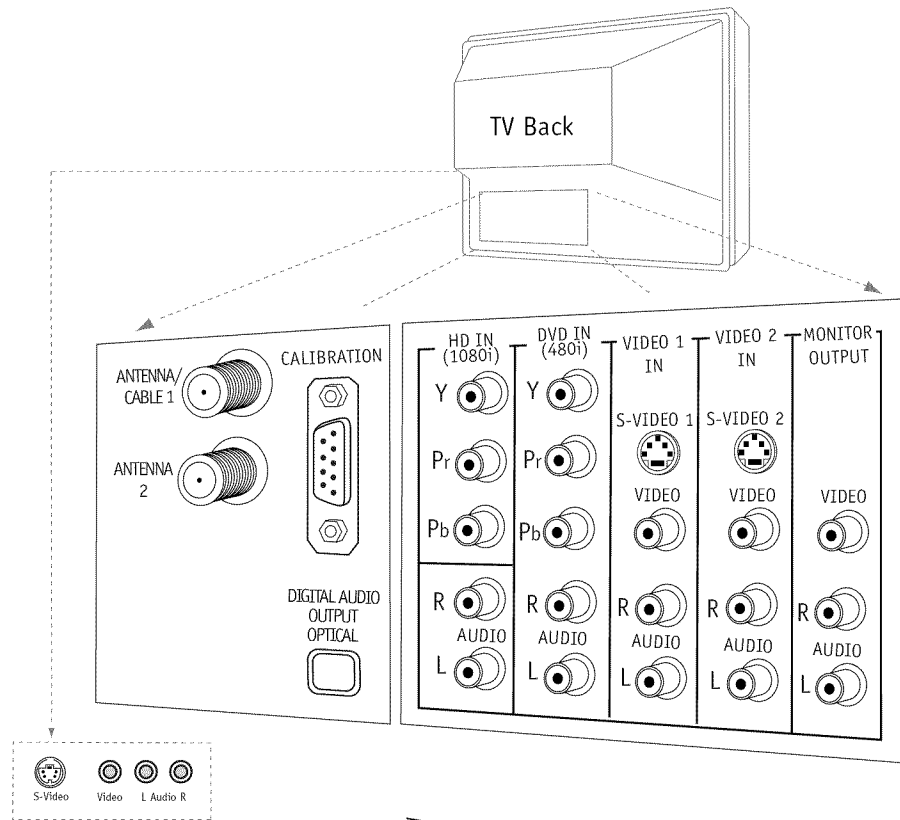

1 Press SOURCE repeatedly to choose from the available input viewing sources.

Analog: Antenna/Cable1 -2 on TV back near Jackpack, Over-the-Air Antenna or Cable service signal source.

Video 1 In: on TV back Jackpack, Set of Composite Audio/Video Input jacks. S-Video Input jack use with Video 1 Audio Input jacks.

Video 2 In: on TV back Jackpack, Set of Composite Audio/Video Input jacks. S-Video Input jack use with Video 2 Audio Input jacks.

F Video In: on TV front Jackpack, Set of Composite Audio/Video Input jacks.

F S-Video In: on TV front Jackpack, S-Video Input jack use with front Audio Input jacks.

DVD IN: on TV back Jackpack, 480i, Set of Component Audio/Video Input jacks.

HD In: on TV back Jackpack, Set of component Audio/Video Input jacks at 1080i.

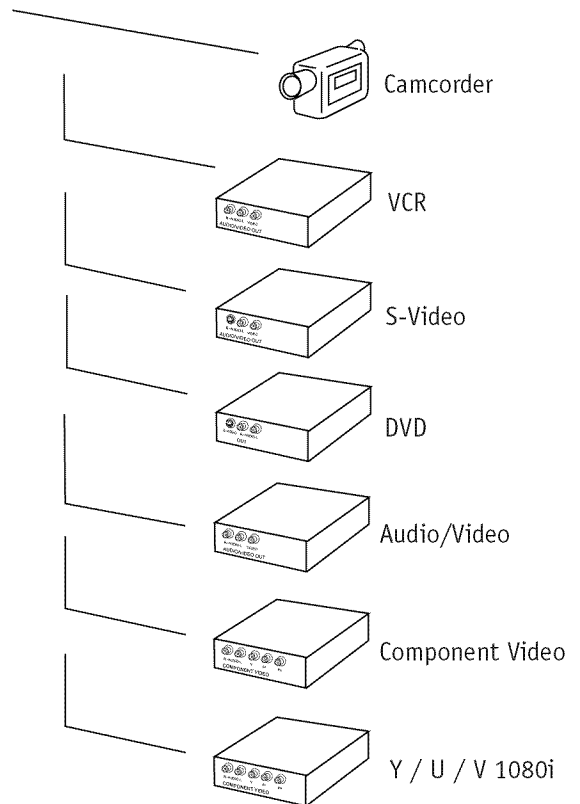

Typical Viewing Sources



The source equipment you intend to view should be turned on.

On-Screen Menu Overview

Descriptions of the menus and displays

Using MENU, the Up/Down arrows, and the ENTER key and the other keys indicated on the remote, the user can access the menus and displays described below.

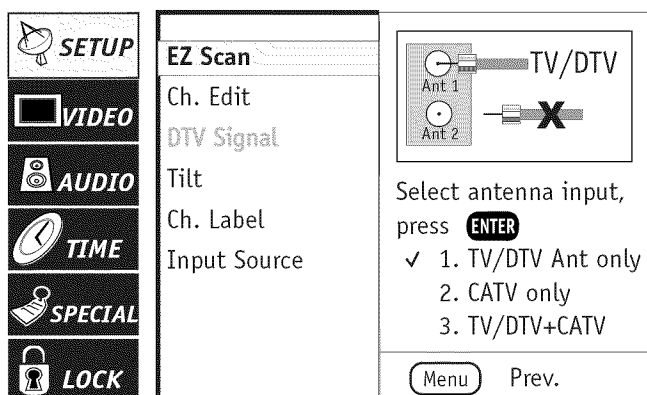

ON-SCREEN MENUS

SETUP pages 18/25 - 29
Sets the TV up and adjusts the basic features.

EZ Scan page 18
Automatically finds and stores all available channels in your viewing area; tune in those channels using Channel Up/Down.

Ch. Edit page 25
Choose which channels will appear when using Channel Up/Down. Adds favorite channels to Surf channel list.

DTV Signal page 26
Shows the strength of the DTV signal being received.

Tilt page 27
If needed, adjusts the picture by tilting it to fit screen.

Ch. Label page 28
Choose a network symbol to identify the channel.

Input Source page 29
Chooses the input source for the picture and sound.

VIDEO page 30
Adjusts the picture appearance to your preference. Your options are:
EZ Picture, Contrast, Brightness, Color, Tint, Sharpness, Color Temperature, Z-View.

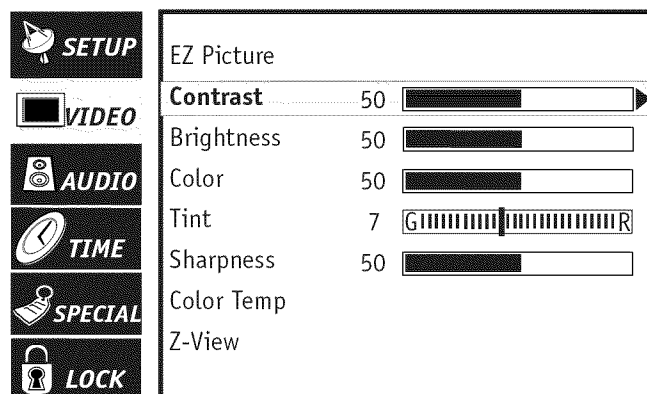

AUDIO page 31
Customizes the sound to suit your room and taste. Your options are:
Audio Mode, EZ Soundrite, EZ Sound, Balance, Treble, Bass, Speakers, Front Surround.

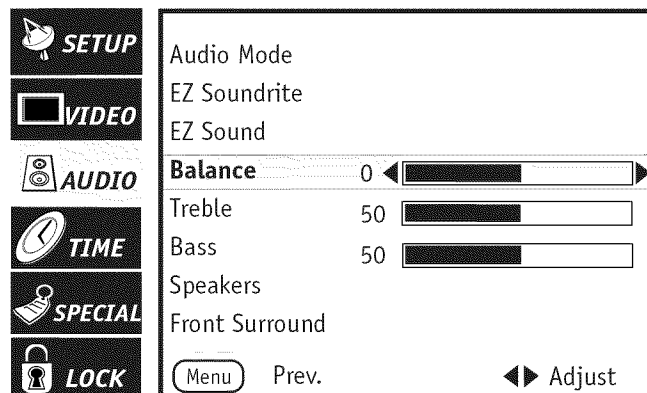

On-Screen Menus/Displays Overview

TIME pages 32 - 34

Sets the TV's internal clock and TV turn on/off functions.

Clock page 32

Sets the current time on the TV.

Off Timer page 33

Sets the time the TV will turn off automatically each day.

On Timer page 33

Sets the time the TV will turn on automatically each day.

Sleep Timer page 34

Sets a time that the TV will automatically turn itself off, one time.

SPECIAL pages 35 - 38

Goes beyond basics and customizes your TV's features. Your options are:

Aspect Ratio page 35

Chooses the correct picture format for the video source.

Analog Caption page 36

Chooses a captioning or text option.

Language page 37

Chooses the language you want the on-screen menus to appear in: English, Spanish, French.

EZ Demo page 38

On/Off. Demonstrates the on-screen menus that control the TV's setup and operational features.

LOCK SYSTEM pages 39 - 40 - 41

Allows parents to block programming based on the program's content rating, A/V source, or block channel(s).

OTHER ON-SCREEN DISPLAYS (See pages indicated.)

- Mute 24
- Volume Display 24
- Channel/Time 23
- Sleep Timer 24
- Captions/Text 23

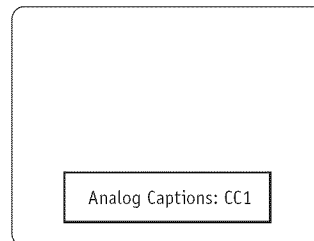
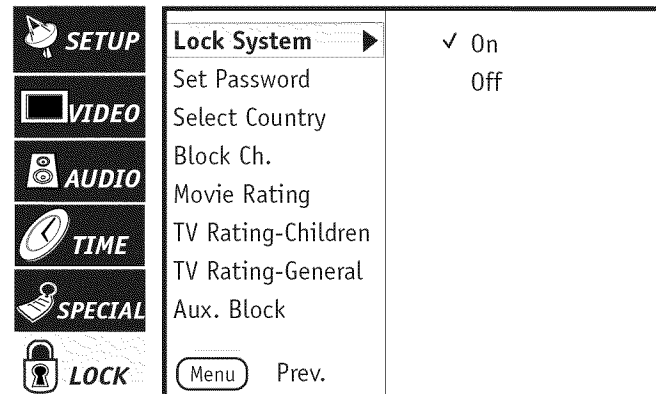
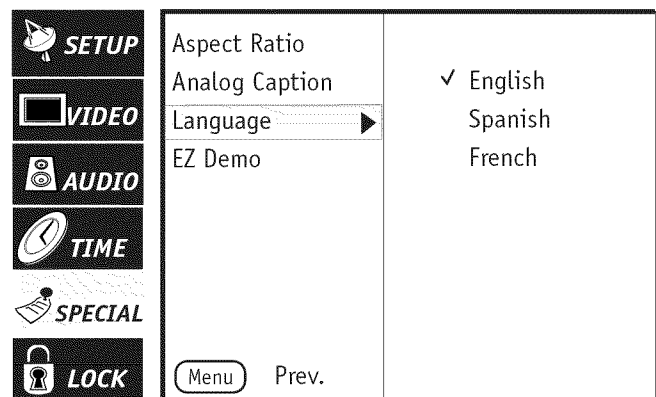
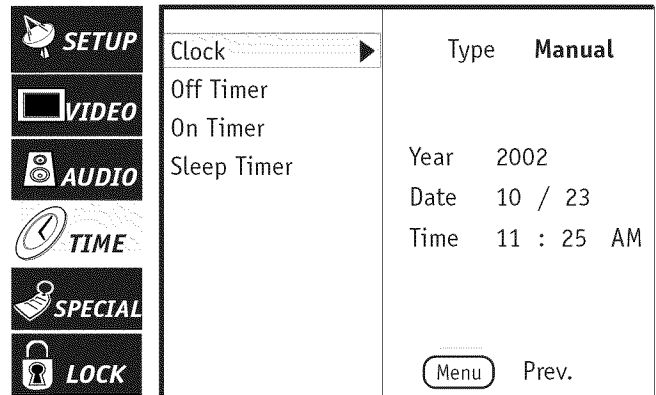

Closed Captions menu display

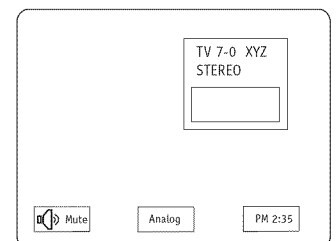

Channel/Time Display

Other Functions & On-Screen Displays

On-screen displays reveal the current status of your Entertainment Machine

A Mute Display

Press MUTE to remove the sound.
Press MUTE again to restore the sound.

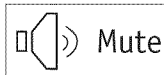

B Volume Display

Press the VOLUME +/- key on the remote control to see the sound level status display.

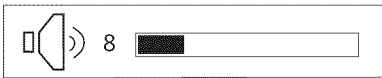

C Channel/Time Display

Press ENTER on the remote control to view the Channel/Time/incoming audio signal, and channel label display.



D Remove On-Screen Displays and Menus Instantly

Press QUIT to remove displays and menus and return to TV viewing, or wait a few moments and the displays and menus will automatically disappear from the screen.

E Sleep Timer Display

Sleep Timer Status Display.

Sleep Time: Off



"Surf" Channels are typically your favorite channels that you tune to and watch frequently.

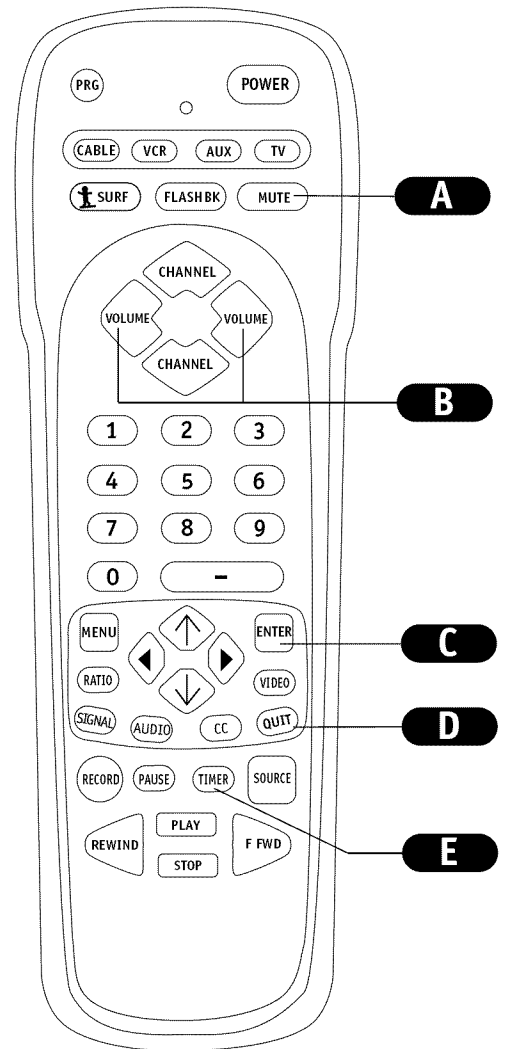

Channel Edit Add/Delete/Surf Setup

Customize your channel selection list: Add Channels, Delete channels you don't watch, Create a favorite channels list to "Surf" - - press SURF repeatedly to scroll your Surf channels

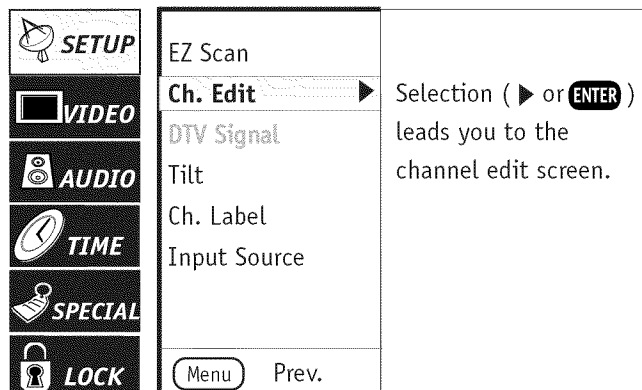

- 1** Press MENU, use the Up/Down arrow to select the SETUP menu, then press ENTER or the right arrow.
- 2** Use the Up/Down arrow to highlight the Ch. Edit option, then press ENTER or the right arrow.
- 3** Use the Up/Down/Left/Right arrows to highlight and select a channel. (Use Channel Up/Down to show next channel group.)
- 4** Press ENTER repeatedly to ADD to or, DELETE the channel from the channel scan. To add the selected channel to the Surf list, press SURF. To go to the next group of channels use CHANNEL Page Up/Page Down.
- 5** Use MENU to go back to the SETUP menu. Press QUIT to remove menu when finished or go to another channel to edit and repeat from Step 3.



If you've deleted a channel, it isn't gone for good. Just select it using the NUMBER keypad on the remote, or add it later.

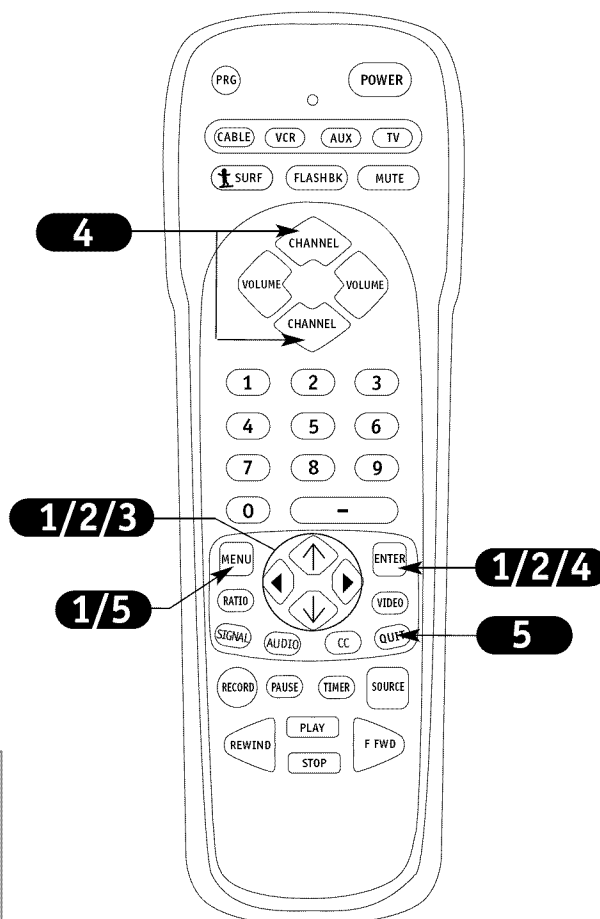

Mini glossary

- ADD** Include a new channel to the channel list that you scroll through using Channel Up/Down.
- DELETE** Remove a channel that you don't watch from the channel list that you scroll through using Channel Up/Down.
- SURF** Adds a favorite channel to the Surf channel list. Press SURF repeatedly, channels you specified as Surf channels will be the only ones to appear. Use Channel Up/Down to return to and scroll the normal channels list.

DTV Input Signal Menu

Go to the DTV Signal option to see the strength of the DTV signal being received

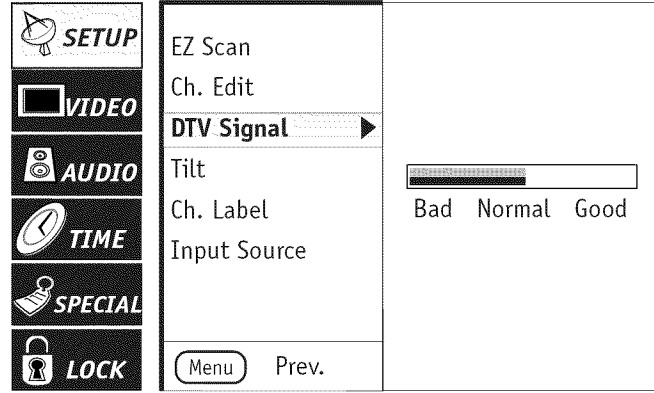
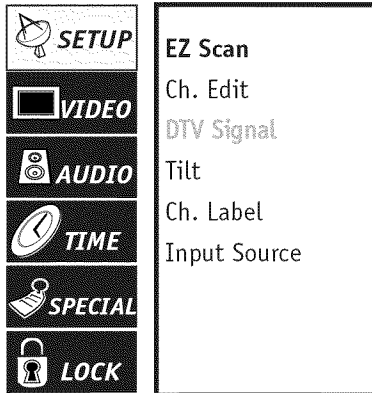

- 1** Press MENU to show the menus on-screen.
- 2** Use the Up/Down arrow to select the SETUP MENU, then press ENTER.
- 3** Use the Up/Down arrow to select the **DTV Signal** option. (Use MENU to go backward as needed.)
- 4** View the on-screen signal strength monitor to see the quality of the signal being received.
- 5** Press QUIT to remove menus and return to TV viewing.



DTV Signal option is only accessible on the Setup menu if the source is DTV.



Press SIGNAL on the remote control to show signal strength.

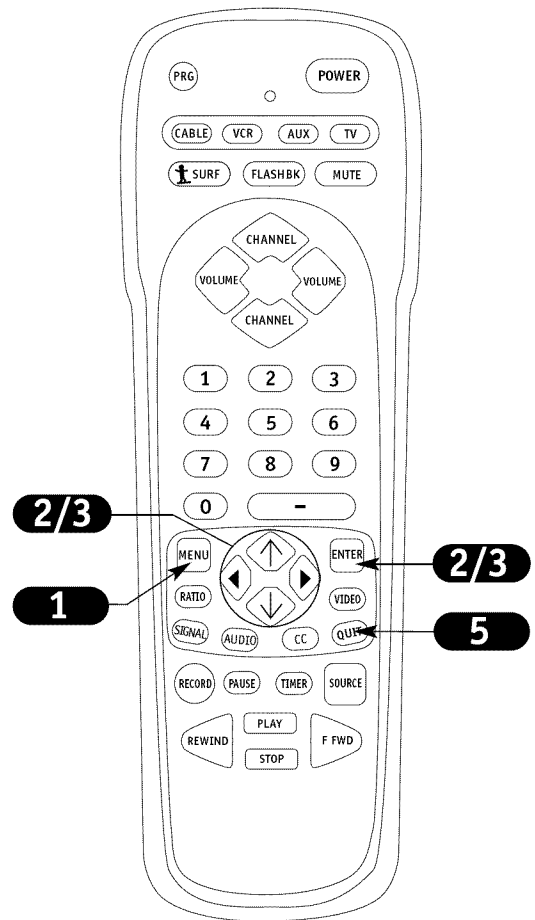

Tilt Menu

Use the **Tilt** option to correct the picture angle, if necessary

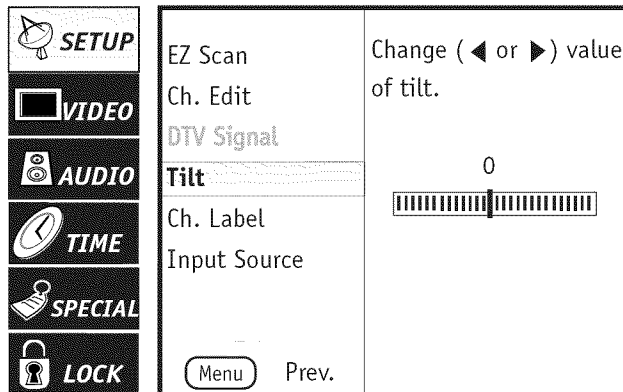
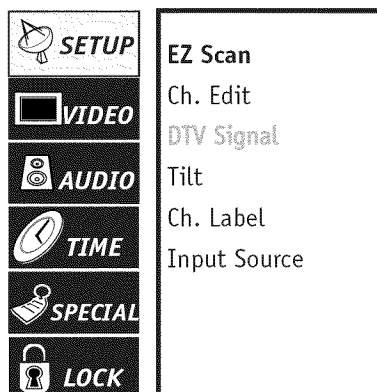

- 1** Press MENU to show the menus on-screen.
- 2** Use the Up/Down arrow to select the **SETUP** MENU, then press ENTER or the right arrow button.
- 3** Use the Up/Down arrow to select the **Tilt** option.
- 4** Use the Left/Right arrow to adjust the **Tilt** of the picture image to your preference.
- 5** Press QUIT to remove menus and return to TV viewing.



The tilt angle you set will be retained in the TV's memory. When the TV is turned on, the tilt angle last set will be used.

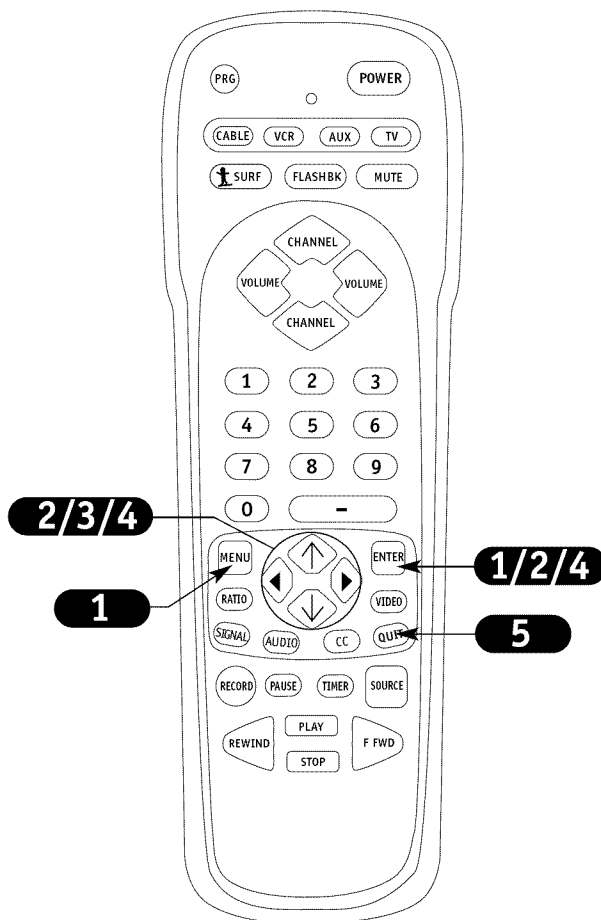

Channel Label Menu

Label the channels with their logos for easier identification when tuning

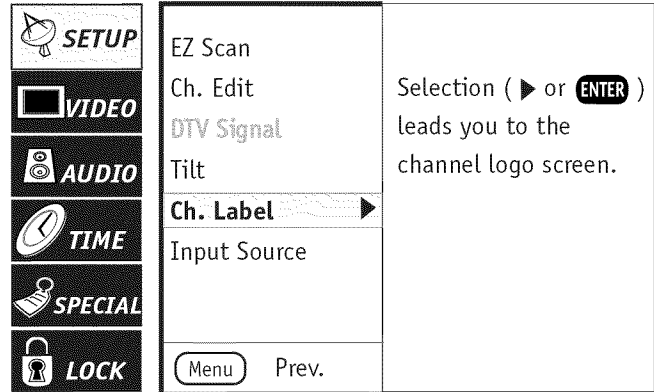
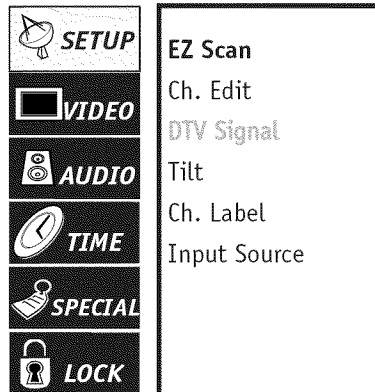

Selection (▶ or ENTER) leads you to the channel logo screen.

- 1** Press MENU, use the Up/Down arrow to select the SETUP menu, then press the right arrow or ENTER.
- 2** Use the Up/Down arrow to select the Ch. Label option on your screen, then press the right arrow or ENTER.
- 3** Tune to the channel you want to label with a logo, using the Channel Up/Down arrows.
- 4** Use the Up/Down/Left/Right arrows to select a logo for the channel, then press ENTER. The logo appears above the channel picture on the menu.
- 5** Tune to another channel to continue labeling or press QUIT to remove menu and to return to TV viewing.

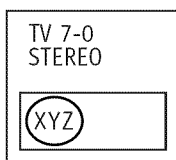

When you press ENTER, the label you have chosen will appear in the channel/time display.



When you scroll through the channels, any label set for a channel will appear in the channel/time display.

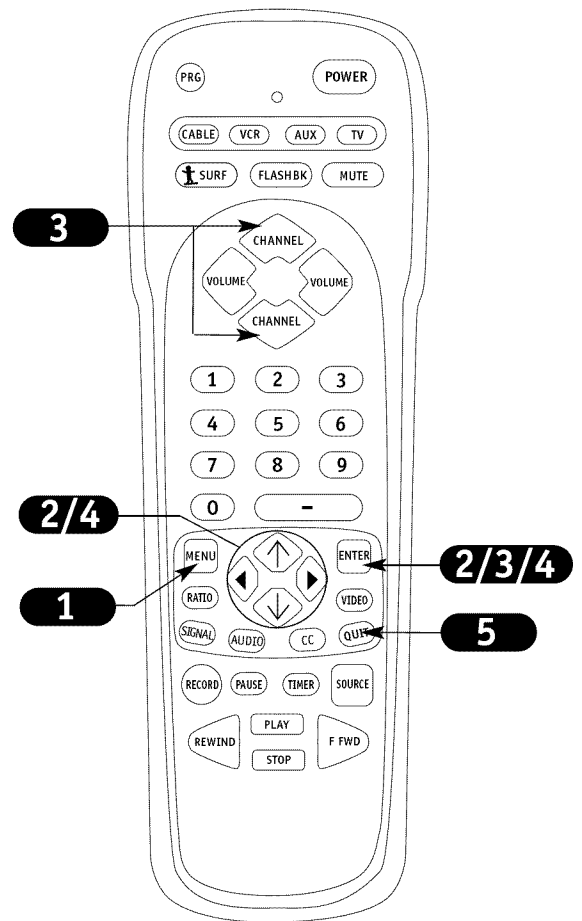

Selecting Input Sources

Choose the picture and sound you want to see and hear for the main screen

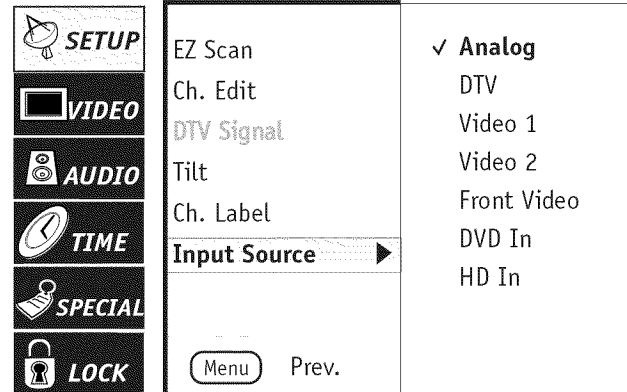
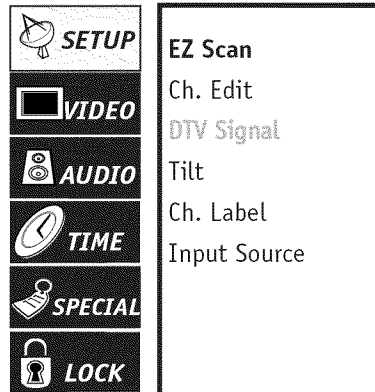

A

Using SOURCE to Choose Viewing Sources

Press SOURCE repeatedly to scroll through the available sources: Analog, DTV, Video 1, Video 2, F Video, DVD, and HD.

1

Selecting Input Source using the Setup Menu

Press MENU to show the menus on-screen.

2

Use the Up/Down arrow to select the SETUP MENU option, then press ENTER.

3

Use the Up/Down arrow to select the Input Source option, then press ENTER. (Use MENU to go backward as needed.)

4

Use the Up/Down arrow to move the checkmark and select Analog, or one of the other available sources.

5

After you have selected a viewing source, press QUIT to remove the menu and return to TV viewing.



If S-Video sources are connected, they will appear on the Source menu as Video 1, 2 etc.



Be sure to use the Video menu to change the Aspect Ratio as needed when using sources which have different picture proportions for the main screen.

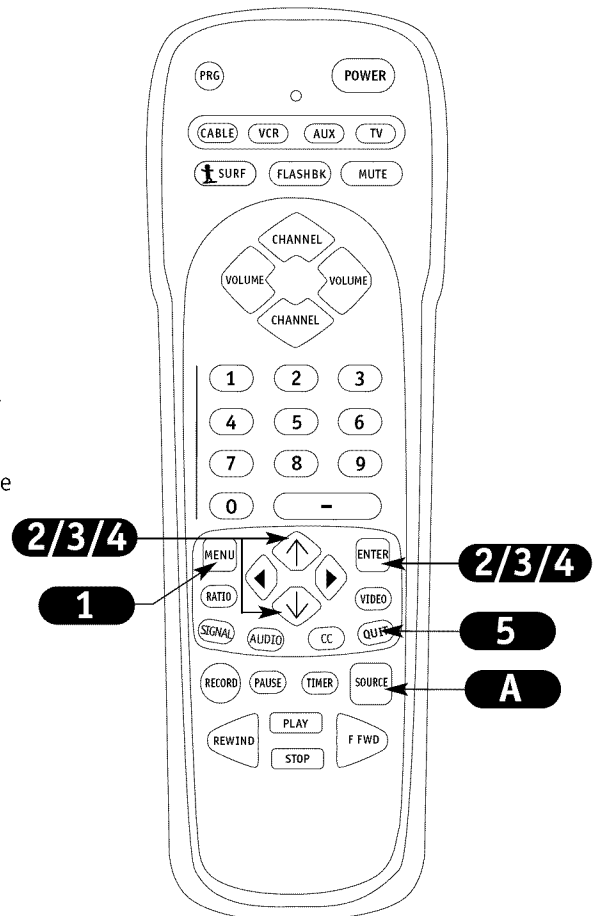

Video Menu

Use the Video menu to customize the picture appearance

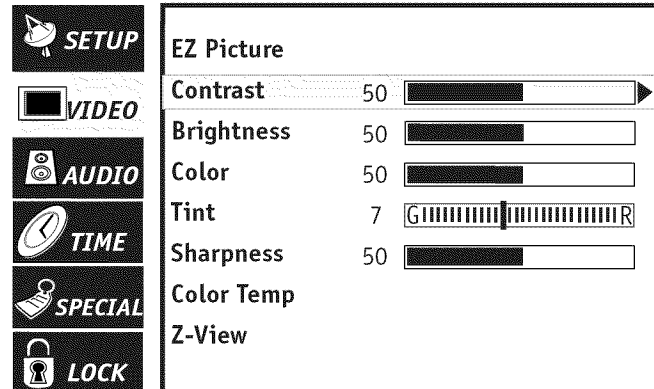
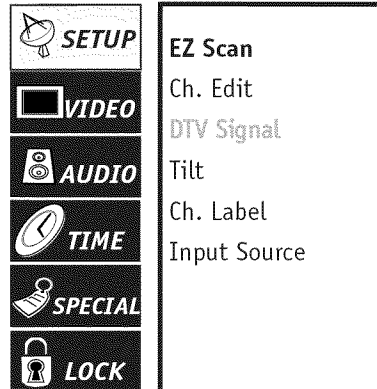

- 1** Press MENU, use the Up/Down arrow to select the Video menu, then press ENTER or the Right arrow.
- 2** Using the Up/Down arrow on the remote control, choose Contrast (or another menu option on your screen), then press the Right arrow twice.
- 3** Using the Left/Right arrow, change the Contrast level to your preference. Use the Up/Down arrow to select other adjustment bars like Brightness, Color, Tint, and Sharpness.
- 4** Press QUIT, to return to TV viewing, or press MENU and repeat from step two to set the other menu options. Your options are:

- **EZ Picture:** Choose either Custom, Normal, Digital Preset, Night Time, Movie, Weak Signal, Video Game, or Sports. Custom: Allows you to adjust the picture the way you want. Normal: Resets all the options to their preset values. Other options adjust the picture to the source's image.
- **Contrast:** Adjusts the level of difference between white and black in the TV picture. The more contrast, the brighter the picture appears.
- **Brightness:** Increases or decreases amount of white in the TV picture.
- **Color:** Adjusts levels of all colors in the TV picture.
- **Tint:** Adjusts the relative amounts of red and green colors in your picture.
- **Sharpness:** Raises or lowers the definition of the picture. The lower the level, the softer the image will appear.
- **Color Temp:** Adjusts levels of all colors in the TV picture; Cool or Warm.
- **Z-View:** On, automatically adjusts the picture display for optimum quality: on or off.



Choose the **NORMAL** option in **EZ Picture** to quickly reset the Video Menu options to their original pre-set values, or use your own settings with **CUSTOM**.

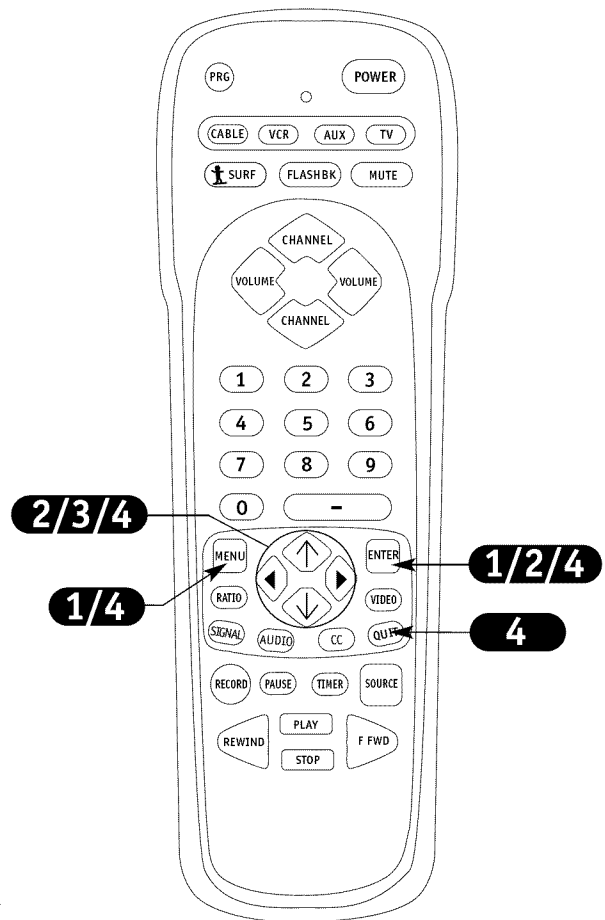

Audio Menu

Adjust the sound to your preference and set up the audio features

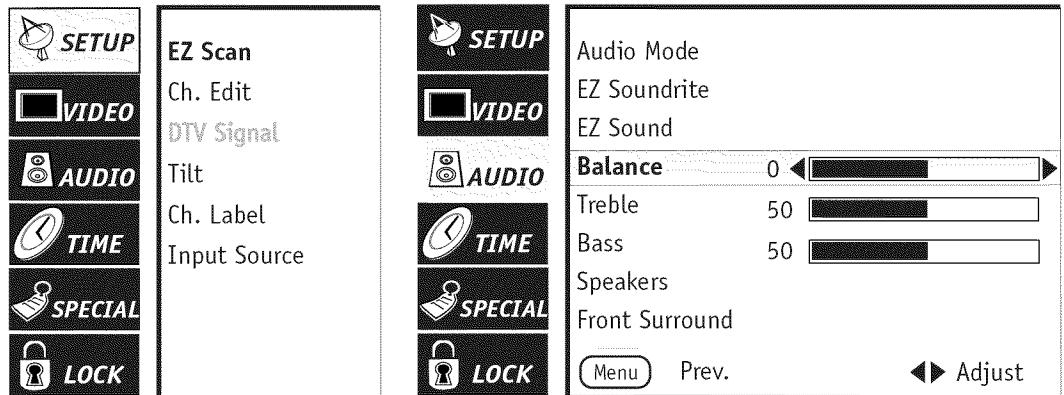

- 1** Press MENU, use the Up/Down arrow to select the Audio menu, then press ENTER or the Right arrow button.
- 2** Using the Up/Down arrow on the remote control, highlight the audio option you want to adjust, then press the Right arrow.
- 3** Using the Left/Right arrow, change the Audio option level to your preference.
- 4** Press QUIT, to return to TV viewing, or press MENU and repeat from step two to set the other menu options. Your options are:
 - **Audio Mode:** Choose from Stereo sound, Mono sound, or 2nd Audio/SAP.
 - **EZ SoundRite:** Turns the uniform volume level on or off.
 - **EZ Sound:** Use one of the five factory audio presets: Normal, Stadium, News, Music, Theater, or your own "Custom" settings.
 - **Balance:** Allows you to put the sound more to the left or right channel.
 - **Treble:** Increases/decreases higher-end sounds.
 - **Bass:** Increases/decreases lower-end sounds.
 - **Speakers:** Turns the TV speakers on or off.
 - **Front Surround:** Turns front surround sound on or off.



Not all programming is broadcast in stereo sound or has 2nd Audio SAP.

Mini glossary

STEREO SOUND	Stereo (stereophonic) sound refers to audio that's divided into right and left sides.
MONO SOUND	Mono (monaural) sound is one channel of sound. For more than one speaker, all the speakers play the same audio.
2nd Audio/SAP	Second audio program provided by some broadcasters; usually a different language.
Front Surround	Front Surround is a stereo effect.

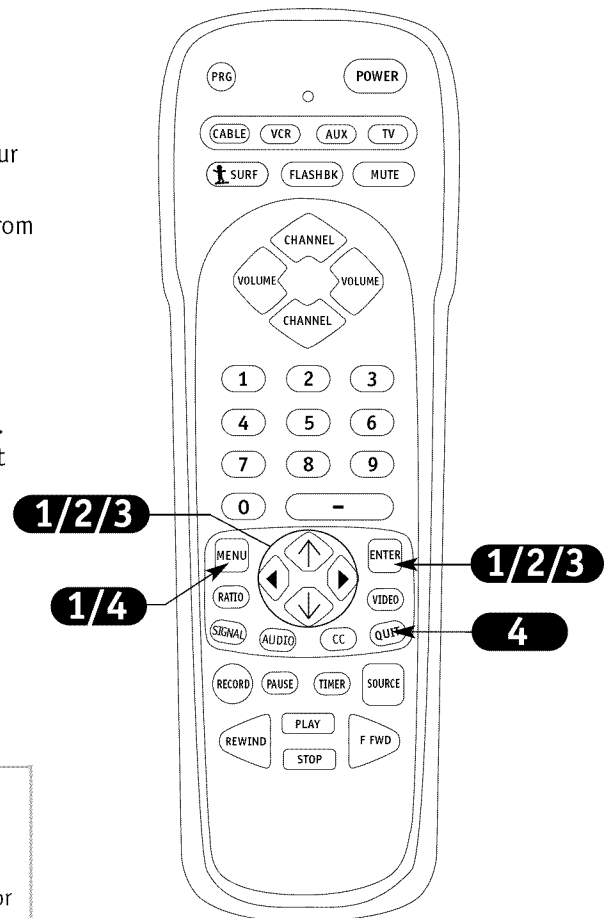

Set the Clock

Set the clock yourself or have the TV do it for you

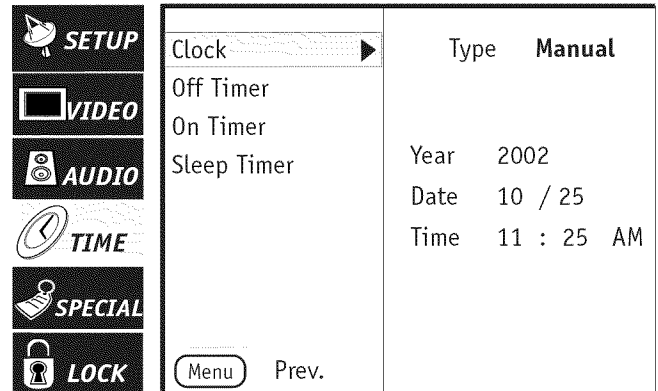
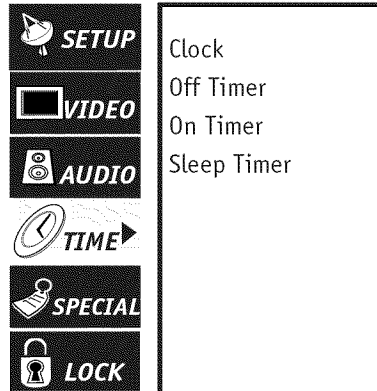

1 In the Time menu with the Clock option highlighted, press ENTER or the right arrow to go to the Clock Menu.

2 Use the Left/Right arrows to move through the menu and the Up/Down arrows to set the clock as indicated on the menu.

Clock Menu Options

Manual Mode

User sets the Clock options.

- **Year:** Set the current year.
- **Date:** Set the Month and Date.
- **Time:** Set the Hours, Minutes, and AM or PM.

Auto Mode

TV sets the clock, but the user can enter the menu and set the appropriate info:

- **PBS Channel:** Set the channel number of your PBS station to receive time from PBS signal.
- **Time Zone:** Set your time zone: Auto, Eastern, Central, Mountain, Pacific., Alaska, Hawaii, New F land, Atlantic.
- **Daylight Savings:** Turn Off or On.

3 Press QUIT to return to TV viewing, or press MENU to return to the previous menu.



The On/Off timers will not work until the Clock on your television has been set.



You need to set the current time manually the first time the TV is connected to power. This will activate the clock.

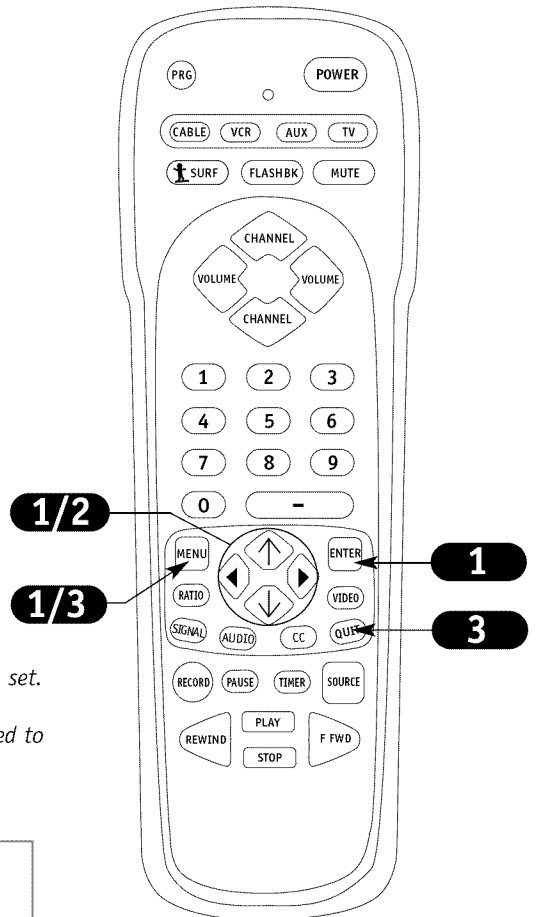

Mini glossary

- TIME** A four-number figure broken down into hours and minutes; first two numbers are hours, last two numbers are minutes.
- HOURS** First two numbers entered when setting the clock.
- MINUTES** Second two numbers entered when setting the clock.

On/Off Timer Menus

Use the On/Off Timers to turn the TV on and off each day at the on and off specified times

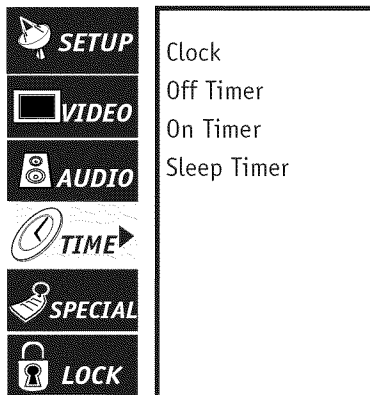

1 With the Time menu selected, use the Up/Down arrows to choose the Off Timer option, then press ENTER or the Right arrow button.

2 Use the Left/Right arrows to move through the menu and the Up/Down arrows to set the Off Timer options, as indicated on the menu.

1 With the Time menu selected, use the Up/Down arrows to choose the On Timer option, then press ENTER or the Right arrow button.

2 Use the Left/Right arrows to move through the menu and the Up/Down arrows to set the On Timer options, as indicated on the menu. Set the TV turn on time, channel, and volume level.

3 Press QUIT to return to TV viewing, or press MENU to return to the previous menu.

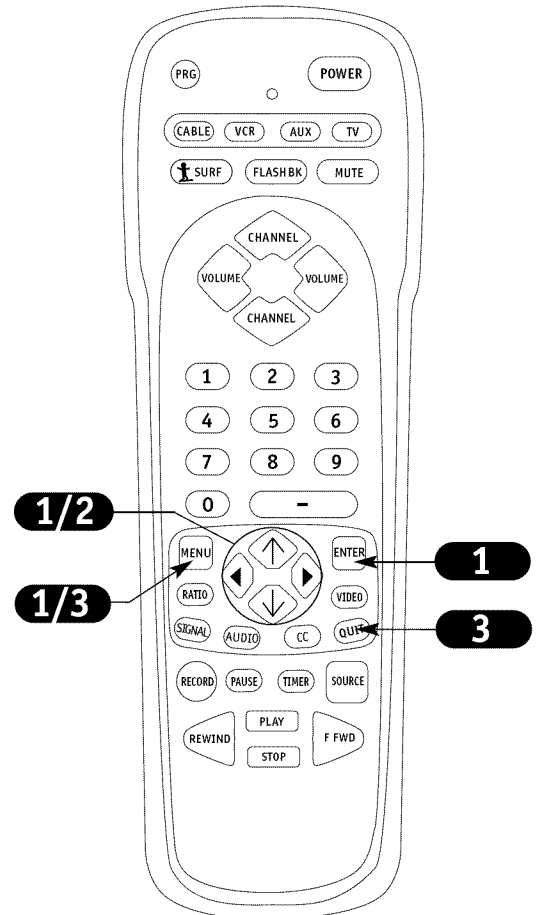

Sleep Timer Menu

Set the Sleep Timer to automatically turn the TV off, after the pre-set time has expired

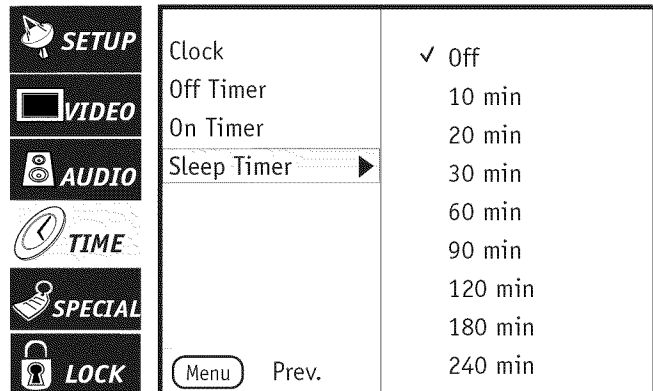
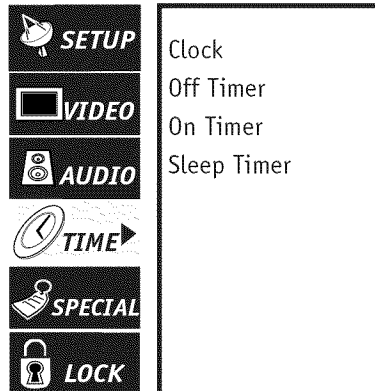

Sleep Timer

- A** Use the TIMER button to choose a preset time from 10 minutes to 4 hours for the TV to automatically turn itself off.

Using the Sleep Timer Menu

Selecting Sleep Timer Menu

- 1** With the Time menu selected, use the Up/Down arrows to choose the Sleep Timer option, then press ENTER or the right arrow button.
- 2** Use the Up/Down arrows to select a preset TV turn-off time from the preset options listed, press ENTER.
- 3** Press QUIT to remove the menu and return to TV viewing.

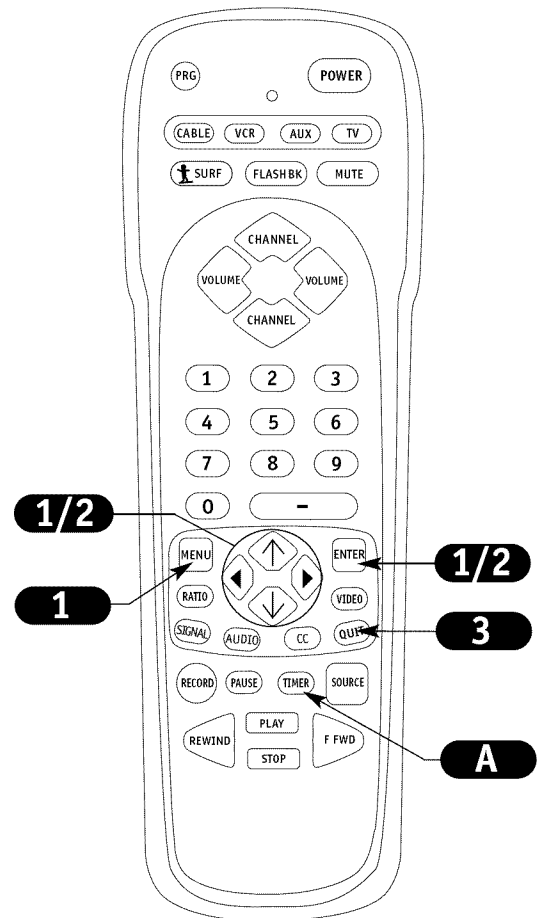

Aspect Ratio Menu

Change the picture aspect ratio to the format required by the selected source

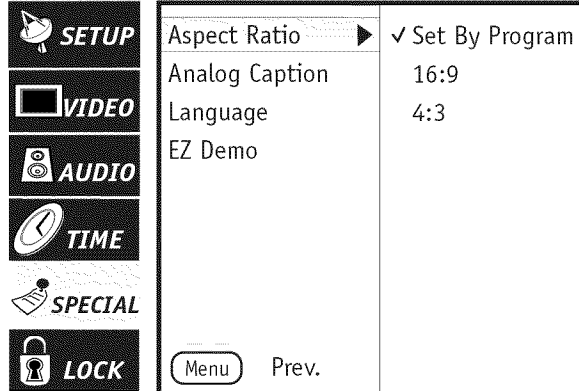
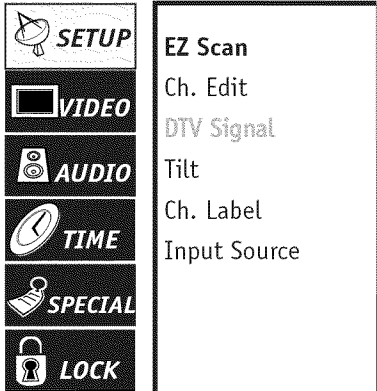

A

Direct Entry Method: RATIO Key
Press RATIO repeatedly to select available aspect ratios for viewing source.

1

Using the Special Menu Option Method
With the Special menu selected, press ENTER or the Right arrow button.

2

Use the Up/Down arrow to select the Aspect Ratio option, then press ENTER or the Right arrow button.

3

Using the Up/Down arrow, choose the correct Aspect Ratio on the menu, then press ENTER.
Your options are:

- **Set By Program:** Selects the proper picture proportion to match the source's image; 16:9, 4:3.
- **16:9:** Selects the proper picture proportion to match the 16:9 source's image.
- **4:3:** Selects the proper picture proportion to match the 4:3 source's image.

4

Press QUIT, to return to TV viewing.



If the Aspect Ratio option is not selectable on the menu, then the picture source is correct and no other options are available.



For Model No. C34W23, Aspect Ratio will be Normal, Wide, or Zoom. As a result, Set by Program, 16:9, and 4:3 are not available.

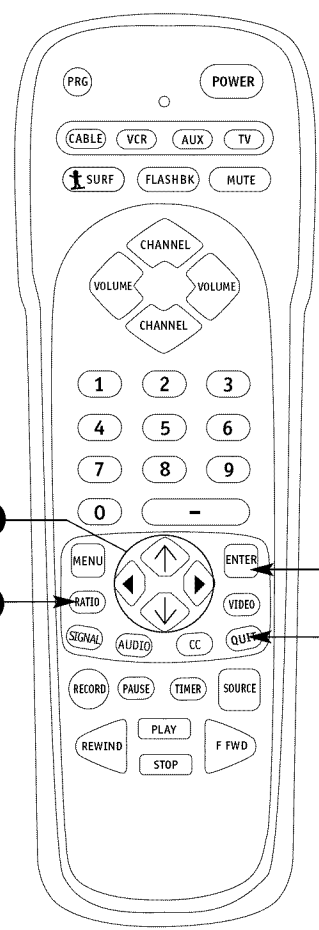

Mini glossary

- 4:3 Standard 4 x 3 almost square-like picture proportion used for most TV formats.
- 16:9 Wider than normal picture format used for HD sources that produce more movie theater-like images.

Analog Caption Menu

Choose a Closed Captions or Text option or turn the feature off

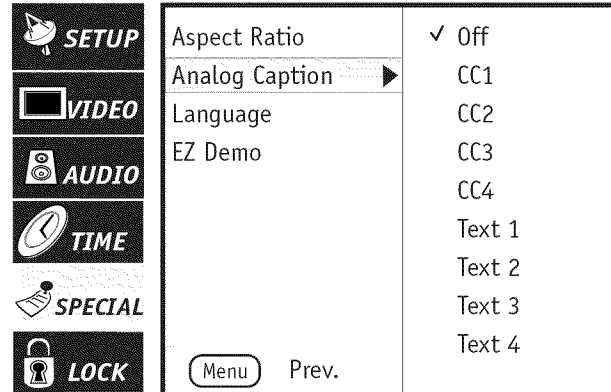
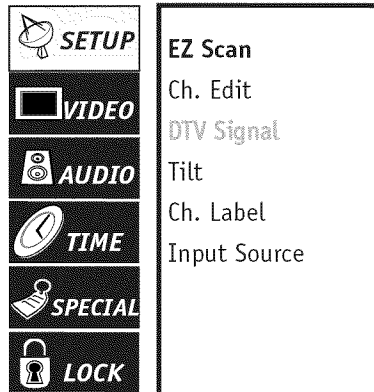

Analog Caption (Caption/Text) allows your TV to receive various closed caption and text options if provided by broadcasters. Availability and functionality of Caption/Text is determined only by the broadcaster and may not be available on a given program. Standard captions are usually on Caption1, standard text is usually on Text 1.

- 1** Press MENU, use the Up/Down arrow to select the Special menu, then press ENTER or the Right arrow button.
- 2** Use the Up/Down arrow to choose Analog Caption, then press ENTER or the Right arrow button.
- 3** Use the Up/Down arrow to select an option from the Analog Caption menu (Caption/Text): Off, Caption 1, Caption 3, Caption 4, Text 1, Text 2, Text 3, or Text 4; so that the option will appear when the TV is tuned to a program that has Closed Captions or Text.
- 4** Press QUIT to remove menu and return to TV viewing.



Standard closed captioning is available using the Caption 1 option.



Not all programming has closed captioning or text available; even though Captions 1, 2, 3, 4, and Text 1, 2, 3, 4 are available to broadcasters.

Mini glossary

CAPTIONS The term for the words that scroll across the bottom of the TV screen; usually the audio portion of the program provided for the hearing impaired.

TEXT The term for the words that appear in a large black frame and almost cover the entire screen; usually messages provided by the broadcaster.

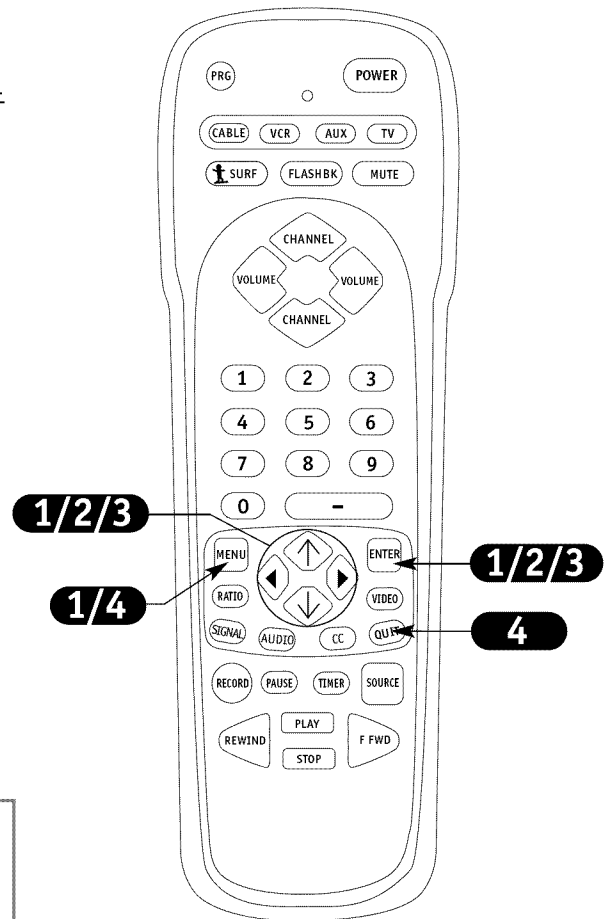

Language Menu

Choose the language you want the on-screen menus to appear in

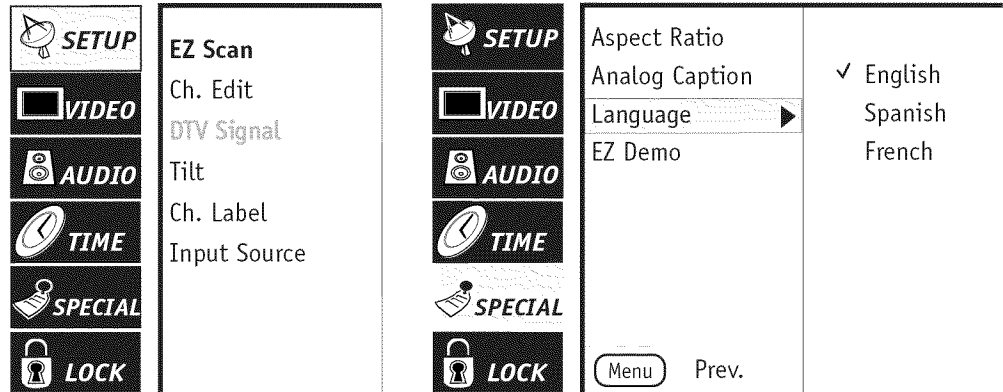

- 1** Press MENU, use the Up/Down arrow to select the Special menu, then press ENTER or the Right arrow button.
- 2** Use the Up/Down arrow to select the Menu Language option on your screen, then press ENTER or the Right arrow button.
- 3** Use the Up/Down arrow to choose any of the following options: English, Spanish, or French, then press ENTER.
- 4** Press QUIT to remove menu and to return to TV viewing.

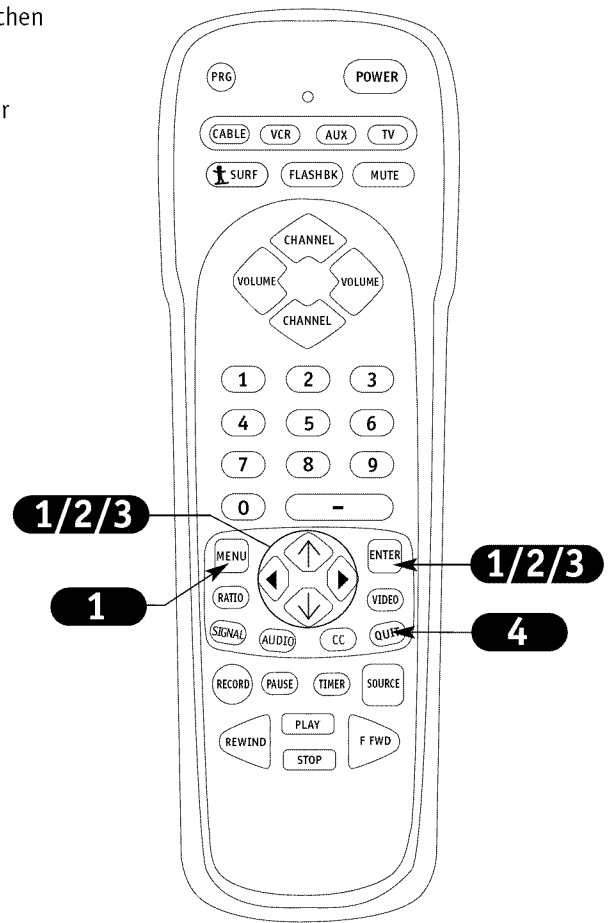

EZ Demo Menu

Your TV can display the menus available

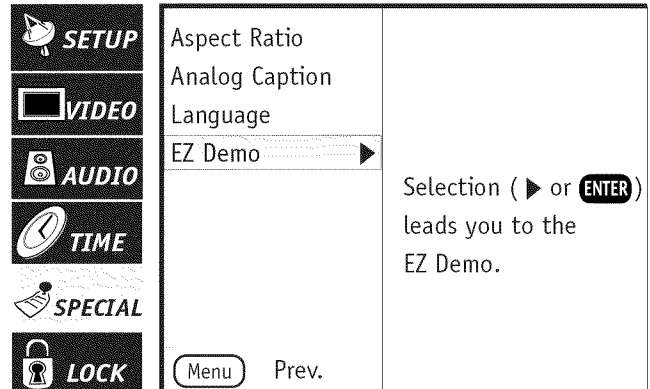
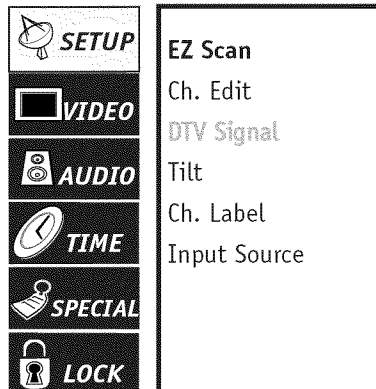

Selection (▶ or **ENTER**) leads you to the EZ Demo.

- 1** Press MENU and use Up/Down arrow to select the SPECIAL menu, then press ENTER or the Right arrow button.
- 2** Use the Up/Down arrow to select the EZ DEMO option.
- 3** When you press ENTER or the Right arrow button, EZ Demo will start and continue to run.
- 4** Press QUIT to stop EZ Demo, remove menu and return to TV viewing.

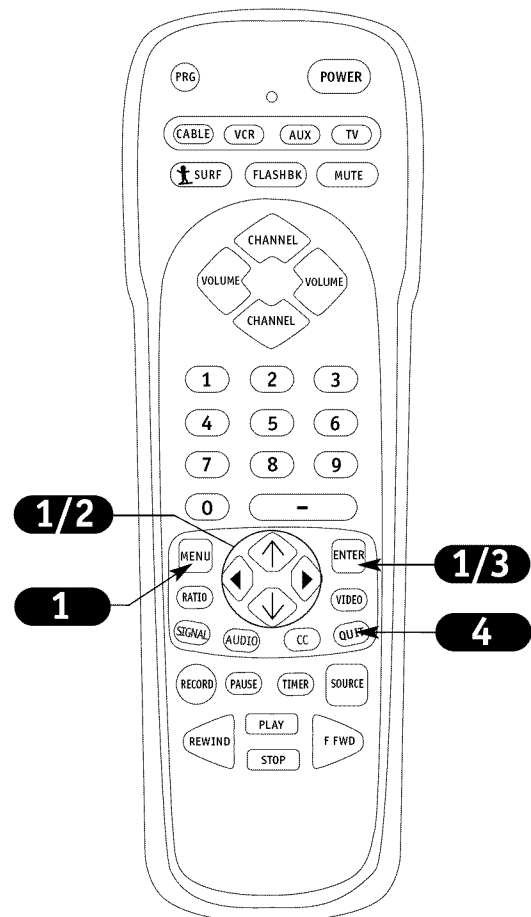

Mini glossary

EZ DEMO Feature provides an automatic demonstration of the on-screen menus available on your TV.
View and learn what features are available to you as EZ Demo cycles through the on-screen menus.

If used, this optional feature can “block” undesirable programming from appearing on the TV.

Note: Lock, is also known and referred to in the text as Parental Control. To block specific source inputs, use the AUX. Block options. Lock options are available by country: USA and Canada. Lock options are also available with TV Ratings for English and TV Ratings for French. Block individual channels if desired.

Lock/Parental Control offers the user a wide variety of options and settings that restrict or “block” the programming that can appear on the TV. Parental control allows the user the capability of defining which program rating they consider acceptable, to the younger or more sensitive viewer. It can be preset and turned either on or off by the user who specifies the secret 4-number code, the password. General audience and children viewer blocks should both be programmed into the TV’s memory. Viewer ratings are specified for both TV and the motion picture industry; both rating systems should be used, for complete coverage. The ratings are based mainly on children’s ages.

Overview

To insure complete coverage for all TV programs, (movies and regular TV shows) choose a rating for MPAA, from the selections AND choose ratings from the TV Parental Guidelines Rating System, using the Age Block option for General Audiences, and for Children. In addition to those, you may wish to add additional restrictions from viewing certain channels. See the Lock menu, and submenus example on the following pages.

Things to Consider before Setting Up Lock (Parental Control)

- Determine which rating you consider acceptable to the viewer. (For example, if you choose TV-PG, all more restrictive ratings will be automatically blocked; the viewer will not be able to see: TV-PG, TV-14, or TV-MA rated programming.)
- Do you want to block the auxiliary video sources? (Blocks the signal sent by the equipment, such as a VCR, connected to the TV Audio/Video input jacks; in the Aux. Block option.) Or leave unblocked, but choose allowable ratings.
- In the TV Rating-General option, block program “Content” based on individual parameters such as: Age, Dialog, Language, Sex, Violence, or in the TV Rating-Children option: Fantasy Violence.
- Select a secret password; in the Set Password option. Use the number keys on the remote. Don’t forget the password, it is the only way you can access the Lock menu and change rating selections, or turn Lock off.
- Do you want Lock to be active all the time? If not, you can turn it on or off; with the Lock On/Off option.



You can set different Parental Control viewing restrictions for general audiences and for children - - both can be active at the same time.



Even if you choose to leave the Aux source inputs unblocked, the ratings you specify will automatically restrict the programming that appears from the video sources.



Simply specifying one content block such as Sex, will not automatically block another content in the programs from appearing.



You cannot disable Lock by disconnecting the TV from power. Lock will automatically reset if power is disconnected.

Lock Menu

After you have read the preceding page, follow instructions below to set up and activate Lock

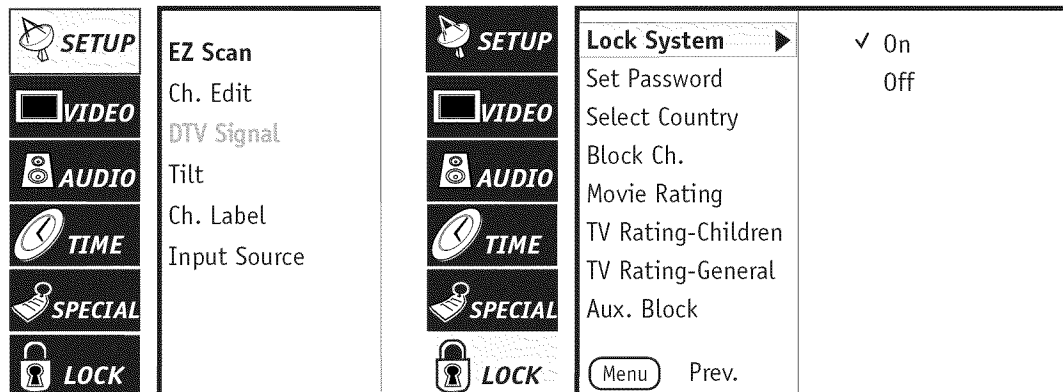

Lock Menu Typical Setup Requirements

As shown above, with the Lock System turned on:

- Set the initial 4-digit password "0-0-0-0" with the number keypad. After setting the password and confirming it, use the Up/Down arrow to highlight an option like TV Rating-General, then press ENTER or the Right arrow.

Navigating Within the Lock Menu

Use the Up/Down/Left/Right arrows to select and adjust or set the rating for an option. For "Language" for example, use the "TV-PG" setting. (See the Mini Glossary, Ratings Charts on this and the next page for rating definitions.) Use MENU to return to the previous menu.

Activating Your Blocking Scheme

After you have selected and adjusted the Lock menu options to your preference:

- Set the Lock System option to either On or Off.

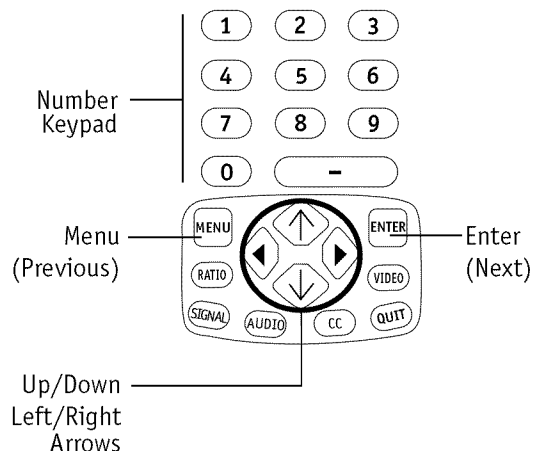

Mini glossary

MOTION PICTURE ASSOCIATION OF AMERICA (MPAA) RATING SYSTEM

G	General Audiences	Content not offensive to most viewers.
PG	Parental Guidance Suggested	Content is such that parents may not want their children to view the program.
PG-13	Parental Guidance Suggested	Program is inappropriate for preteens, with a greater degree of offensive material than a PG rated program.
R	Restricted viewing	Not for children under age 17. Strong elements of sex and/or violence.
NC-17	Restricted Viewing	Not for children under age 17 under any circumstances. Strong sexual content.
X	Hard Core Films	Same as NC-17 rating.

Note: Zenith Electronics Corporation is not liable for any program content that appears when using this rating system; as always, user discretion is advised.

Lock System Menu Structure

Lock System menus with various restriction options are shown below

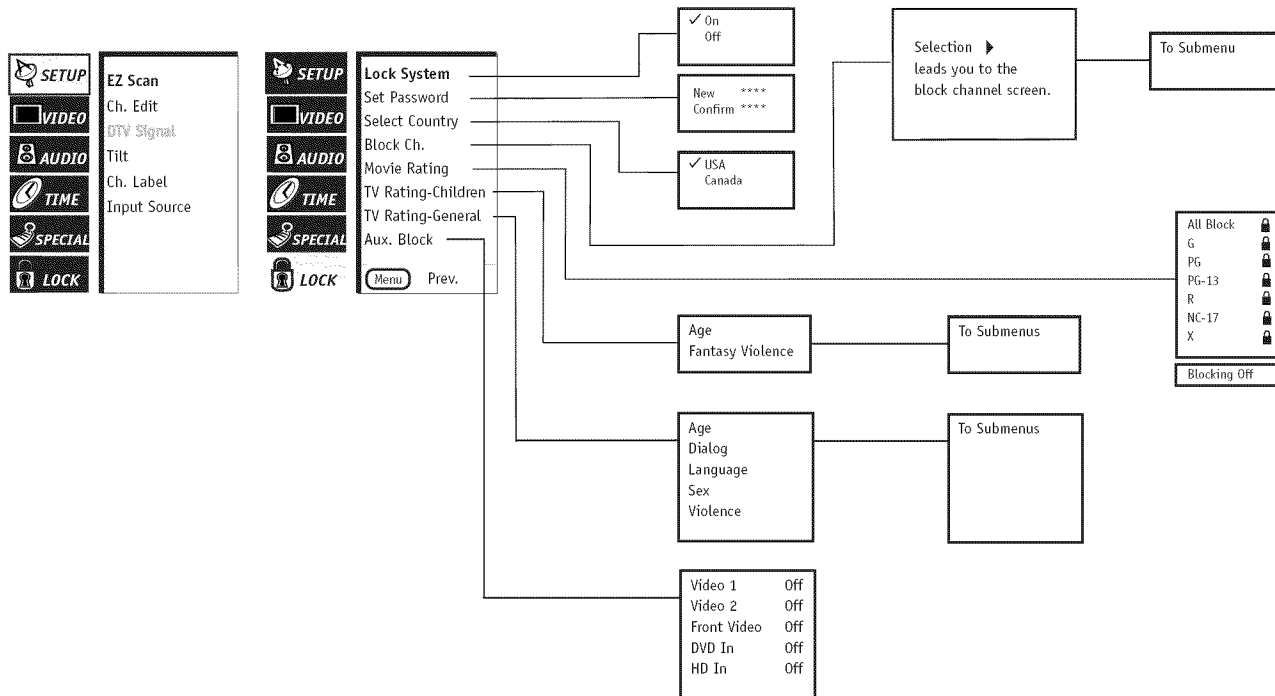

Mini glossary

TV PARENTAL GUIDELINE RATING SYSTEM

TV-G	General Audience	Considered suitable for all audiences; children may watch unattended.
TV-PG	Parental Guidance Suggested	Unsuitable for younger children, may contain: Suggestive Dialog, Bad Language, Sex, and Violence Scenes.
TV-14	Parents Strongly Cautioned	Unsuitable for children under 14, may contain: Strong Dialog, Bad Language, Sex, and Violence Scenes.
TV-MA	Mature Audience Only	Adults only, may contain: Strong Dialog, Bad Language, Sex, and Violence Scenes.

CHILDREN'S CLASSIFICATIONS

TV-Y	Children	Considered suitable for all children under 7 years old.
TV-Y7	Children 7 and over	Considered suitable for children over 7, may contain Fantasy Violence Scenes.

Programming the Remote

Set up your remote to operate other brand name devices

- 1** Turn on the device you want to program.
- 2** On the chart on page 46/47, find the type of device you're programming, and then find the brand name. Write down the three-number code(s).
- 3** Press and hold PRG. It's recessed so it doesn't get pushed accidentally. Use a small, blunt object. When the indicator light turns on, you can release PRG.
- 4** Push the button name with the type of device you're programming: VCR, CABLE, AUX, TV.
- 5** Using the NUMBER keypad, enter the three-number code you found on page 46/47.
- 6** Press ENTER to save the code. (The indicator light will flash 2 times, then turn off to indicate the code is valid.)
- 7** Point the remote at the device and push POWER. It should turn off. If not, try the other codes listed and continue from step three.
Note: To reset remote to factory settings, enter 9-1-1, in Step 5.



Programming your Zenith remote may allow you to use one remote to operate up to 4 different devices, if all modes are programmed.



Once the device turns off, try the other functions. If they do not operate, try another code. Or, see page 45.



Not all devices will operate with your Zenith remote control.

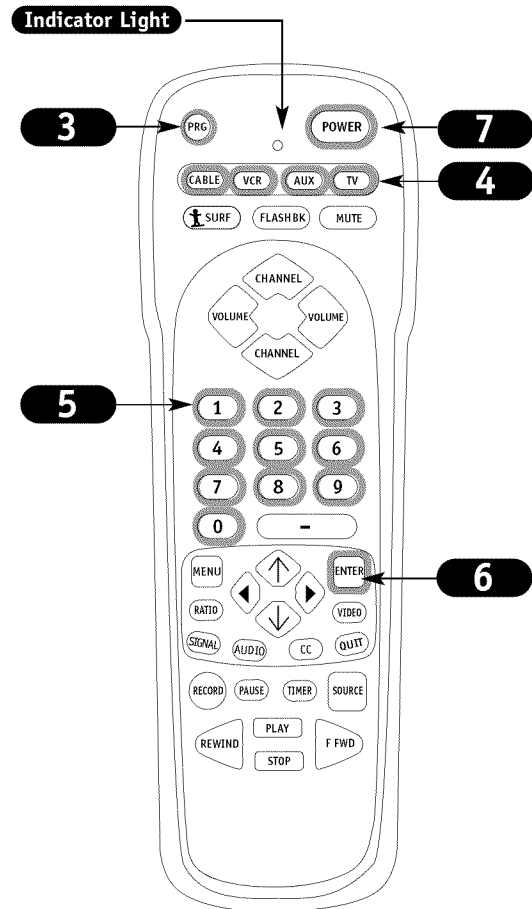

Mode / Product Compatibility			
TV	VCR	CATV	AUX
TVs	VCRs DVDs	Cable Boxes, Satellite Receivers	All products on pp 46 - 47

Mini glossary

PROGRAMMING	Procedure to set up remote to operate other equipment.
PRG	Programming mode button.
DEVICE	Infra-red remote controllable electronic accessory devices.

Mode Sound Switch Setup

This feature is typically used to set up the remote to control the sound from an external audio system, or cable box, without changing modes

Note: Check to make sure the remote operates the device you want to hear. If not, see the remote programming page.

1 With a small blunt object, press and hold PRG until the LED indicator light turns on (about 3 seconds), then release PRG.

2 Press the mode button of the device you want to hear: CABLE, VCR, AUX, TV.

3 Press the Vol+ button, the LED will blink.

4 Press the button of the mode you want the volume to be controlled by: CABLE, VCR, AUX, TV.

5 Press ENTER to save the code (The indicator light will flash 2 times and then turn off).

For example: If you want the VCR mode to control the volume of the AUX mode (audio system), press VCR in Step 2 and press AUX in Step 4. Then, when you press volume in VCR mode, the device programmed for the AUX mode will respond.

Default Mode Volume Control Setups

Mode	Sound controlling mode
TV	TV (Controls TV volume.)
VCR	TV (Controls TV volume.)
AUX	AUX (Controls AUX Volume.)
CABLE	CABLE (Controls Cable Volume.)



If you can't find the code for your amplifier, use the Auto Search feature described on page 45.

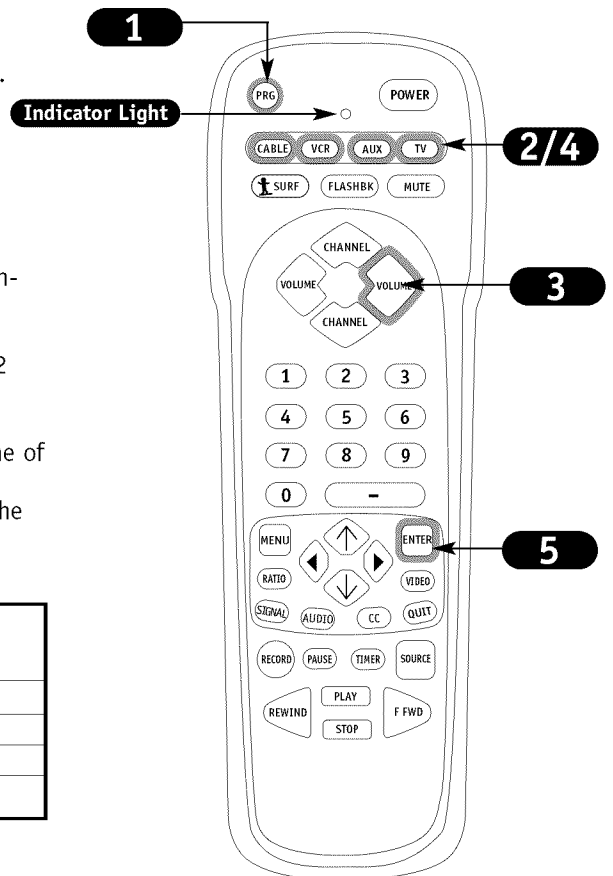

Mini glossary

AMPLIFIER	Audio device which sends sound to speakers, like an Audio Tuner, Receiver, or Amplifier. See Audio Tuners/Amp list on page 47.
CABLE BOX VOLUME	Some cable boxes have volume controls.
AUX	Auxiliary equipment.

Verify 3-Digit Code Stored in Mode

Use the following method described below to find the code number stored in memory for each remote operating mode: TV, VCR, CABLE, and AUX

1 With a small blunt object, press and hold PRG for about three seconds. When the light turns on, release PRG.

2 Press the mode button you want the 3-number code for, then press the TIMER button.

The LED will blink the number of times to indicate the number of the first digit. There will be a 1 second pause during which the LED light will be off, then the LED will blink the number of times for the second digit of the code, and so on. For example:

- One blink, no LED light for 1 second.
- Three blinks, no LED light for 1 second.
- Eight blinks.

This is the example for code: 1-3-8.

Note: Ten blinks indicate code number "0".



Programming your Zenith remote may allow you to use one remote to work up to 4 different devices, if all modes are programmed.



Not all devices will work with your Zenith remote control.

Mode / Product Compatibility			
TV	VCR	CATV	AUX
TVs	VCRs DVDs	Cable Boxes, Satellite Receivers	All products on pp 46 - 47

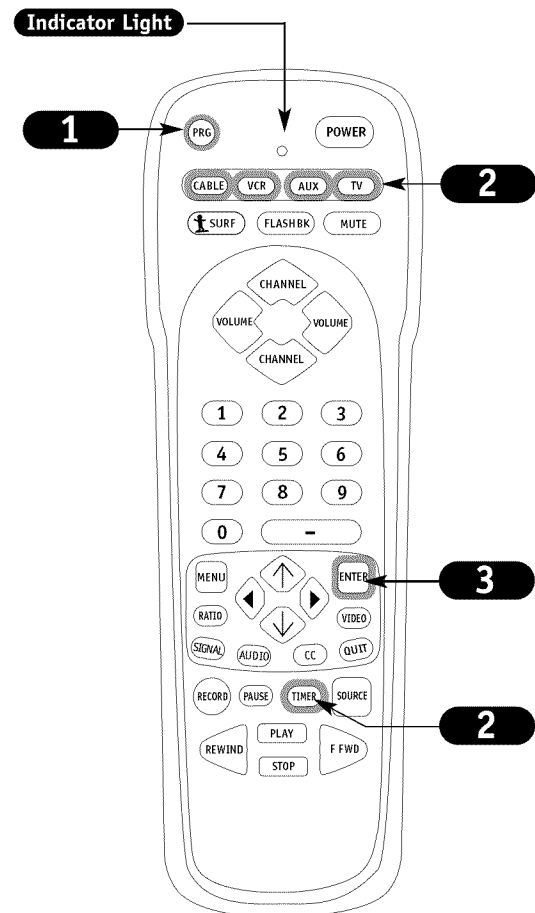

Mini glossary

PROGRAMMING	Procedure to set up remote to operate other equipment.
PRG	Programming mode key.
DEVICE CODE	Code to control infra-red remote controllable electronic devices: TVs, VCRs, Cable Boxes, etc.

Brand Code Auto Search

Use Auto Search to try all available brand codes to determine if your multi-brand remote control can operate the device

1 Turn on the device you want to program the remote to operate.

2 With a small blunt object, press and hold PRG until the indicator light turns on (about 3 seconds), then release PRG.

3 Press the button for the device you are trying to program: CABLE, VCR, AUX, or TV.

4 Press and hold the CH+ or CH- button. When the device turns off, release the CH+ or CH- button. (During this procedure the remote sends out a series of power on/off codes.)

5 To check the code, aim the remote at the device and press the POWER button to turn the device on and off. Try other buttons on the remote to operate other functions to determine if they are also functional.

6 Push ENTER to save the code (The indicator light will flash 2 times and then turn off).

7 Press POWER to turn the device back on.



You can quickly get out of Auto Search by pressing PRG or not pressing any button for 20 seconds.



The Zenith remote may not be able to operate the device. If so, use the device's original remote control.

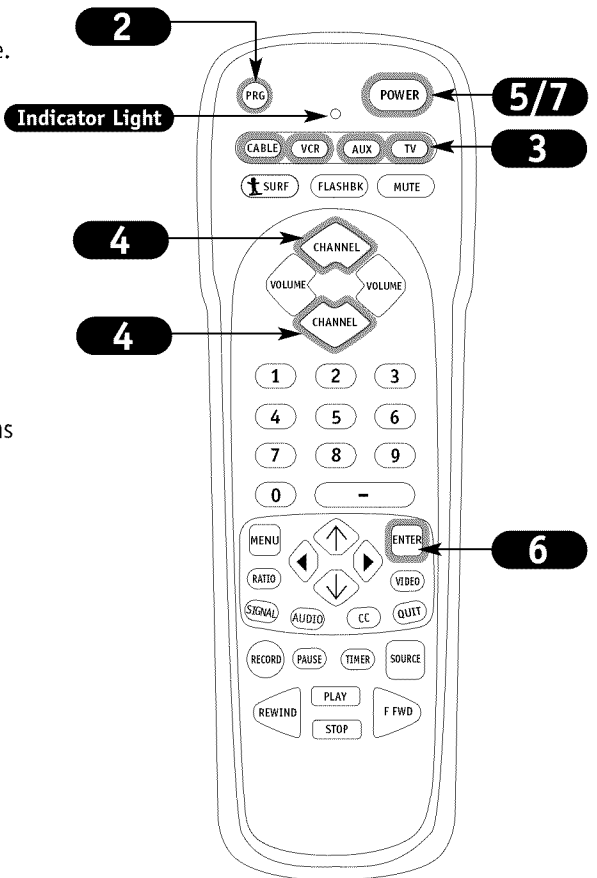

Mini glossary

Auto Search Another way of finding a brand code for controlling auxiliary equipment such as a VCR, DVD player, etc. that is not available through the regular remote brand code programming method.

Programming Codes

Other Manufacturers Brand Names and Programming Codes

TVS

A MARK	112 143		056 073 074 091 116	NAD	015 025		029 081 143 170 175
ADMIRAL	072 081 161		130 144 155 160 161	NEC	006 007 016 019 024	SIEMENS	088
AKAI	006 146	GOLDSTAR	004 102 106 110 112	NIKEI	040 056 130 132 134	SIGNATURE	072
AMPRO	073 167		113 116 119 122 127	ONKING	043	SONY	041 070 079 085 126
AMSTRAD	052		137 143	ONWA	043		139 147 185
ANAM	043 054 056 080 104	HALL MARK	004 116	OPTONICA	019 081	SOUNDESIGN	003 004 028 043 116
	108 112 115 118 121	HITACHI	004 006 009 010 011	PADIO SHACK	004	SPECTRICON	112
	131		012 023 041 075 143	PANASONIC	034 056 080 092 164	SSS	004 043
AOC	004 006 058 112		158 163 166	PHILCO	003 004 006 024 043	SUPRE MACY	002
BLAUPUNKT	088	INFINITY	164		056 059 060 063 064	SYLVANIA	003 004 006 044 059
CANDLE	002 003 004 006	INKEL	129	PHILIPS	127 143 164		060 063 064 116 127
CAPEHART	058	JBL	164		003 004 005 006 038	TANDY	081
CETRONIC	043	JCPENNY	004 006 008 009 024		059 070 093 143 160	TATUNG	056 062
CITIZEN	002 003 004 006 043		030 065 101 143 156	PIONEER	164	TECHNICS	034 080 084
	101 103 143	JENSEN	160		006 018 023 025 027	TECHWOOD	004
CLASSIC	043	JVC	013		116 135 176	TEKNIKA	002 003 004 006 024
CONCERTO	004	KEC	034 038 070 083 145	PORTLAND	004 143		028 031 043 072 077
CONTEC	039 043 050 051	KENWOOD	043	PROSCAN	144 160 161 165 167		101 103 143
CORONADO	143	KLOSS	006 070	PROTON	004 058 116 131 143	TELEFUNKEN	037 046 086 087
CRAIG	043 054	KMC	002 059	QUASAR	171 173	TELERENT	072
CROWN	043 143	KTV	006 043 143 154	RADIO SHACK	034 056 092	TERA	172
CURTIS		LG	255		019 043 047 116 127	TMK	004 116
MATHES	004 006 101 116 143	LODGENET	072	RCA	143	TOSHIBA	007 015 030 040 051
CXC	043	LOGIK	072		004 006 023 024 056		062 101 138
DAEWOO	004 016 017 043 044	LUXMAN	004		065 074 144 152 156	TOTEVISION	143
	055 071 076 103 107	LXI	007 015 052 081 160	REALISTIC	160 161 165	UNIVERSAL	008 009
	111 114 117 120 123	MAGNAVOX	164 166		007 019 043 047	VIDEO	
	125 127 128 136 143		003 004 006 022 059	ROCTEC	186	CONCEPTS	146
DAYTRON	004 116 143		060 061 063 064 127	RUNCO	168 169	VIDIKRON	174
DYNASTY	043	MARANTZ	143 160 164	SAMPO	004 006 058 116	VIDTECH	004 116
DYNATECH	062	MATSUI	006 077 164	SAMSUNG	004 050 089 101 105	WARDS	004 008 009 019 028
ELECTROHOME	024 077 143	MEMOREX	164		113 116 127 133 137		060 061 063 064 072
EMERSON	004 005 006 028 043	METZ	004 007 072 116	SANYO	143 160		074 116 143 164
	047 048 050 051 096	MGA	004 006 024 028 042		007 020 021 033 039	YAMAHA	004 006
	116 143 151 153 154		049 077 116	SCOTT	053 057 082 166	YORK	004 116
	155	MINERVA	088		004 028 043 048 116	YUPITERU	043
FISHER	007 057	MITSUBISHI	004 006 024 028 040	SEARS	143	ZENITH	001 072 073 095 103
FUNAI	028 043		042 109 116 124 146		004 007 015 028 030		157
FUTURETECH	043	MTC	004 006 062 101	SHARP	057 082 094 101 116	ZONDA	112
GE	004 006 008 009 034				143 160		

VCRs

AIWA	034	HARMAN KARDON	012 045	NEC	012 023 039 043 048		073 081 101
AKAI	016 043 046 124 125	HITACHI	004 018 026 034 043	NORDMENDE	043	SHARP	031 054 149
	146		063 137 150	OPTONICA	053 054	SHINTOM	024
AMPRO	072	INSTANT REPLAY	031 033	PANASONIC	066 070 074 083 133	SONY	003 009 031 052 056
ANAM	031 033 103	JCL	031 033		140 145		057 058 076 077 078
AUDIO		JCPENNY	012 013 015 033 040	PENTAX	013 020 031 033 063	SOUNDESIGN	149
DYNAMICS	012 023 039 043		066 101	PHILCO	031 034 067	STS	034
BROKSONIC	035 037 129	JENSEN	043	PHILLIPS	031 033 034 054 067	SYLVANIA	013
CANON	028 031 033	JVC	012 031 033 043 048		071 101		031 033 034 059 067
CAPEHART	108		050 055 060 130 150	PILOT	101	SYMPHONIC	034
CRAIG	003 040 135	KENWOOD	152	PIONEER	013 021 048	TANDY	010 034
CURTIS			048	PORTLAND	108	TATUNG	039 043
MATHES	031 033 041	LG	154	PULSAR	072	TEAC	034 039 043
DAEWOO	005 007 010 064 065	LLOYD	034	QUARTZ	011 014	TECHNICS	031 033 070
	108 110 111 112 116	LXI	003 009 013 014 017	QUASAR	033 066 075 145	TEKNIKA	019 031 033 034 101
	117 119	MAGIN	034 101 106	RCA	041 062 063 107 109	THOMAS	034
DAYTRON	108	MAGINAVOX	040		140 144 145 147	TMK	006
DBX	012 023 039 043		031 033 034 041 067	REALISTIC	003 008 010 014 031	TOSHIBA	008 013 042 047 059
DYNATECH	034 053		068		033 034 040 053 054		082 112 131
ELECTROHOME	059	MARANTZ	012 031 033 067 069		101	TOTEVISION	040 101
EMERSON	006 017 025 027 029	MARTA	101	RICO	058	UNITECH	040
	031 034 035 036 037	MATSUI	027 030	RUNCO	148	VECTOR RESEARCH	012
	046 101 129 131 138	MEI	031 033	SALORA	014	VICTOR	048
	153	MEMOREX	003 010 014 031 033	SAMSUNG	032 040 102 104 105	VIDEO	
FISHER	003 008 009 010		034 053 072 101 102		107 109 112 113 115	CONCEPTS	012 034 046
FUNAI	034		134 139		120 122 125	VIDEOSONIC	040
GE	031 033 063 072 107	MGA	045 046 059	SANSUI	022 043 048 135	WARDS	003 013 017 024 031
	109 144 147	MINOLTA	013 020	SANYO	003 007 010 014 102		033 034 040 053 054
GO VIDEO	132 136	MITSUBISHI	013 020 045 046 049		134		131
GOLDSTAR	012 013 020 101 106		051 059 061 151	SCOTT	017 037 112 129 131	YAMAHA	012 034 039 043
	114 123	MTC	034 040	SEARS	003 008 009 010 013	ZENITH	001 034 048 056 058
		MULTITECH	024 034		014 017 020 031 042		072 080 101

VCR/DVDs

APEX DIGITAL 222
 DENON 220 214
 GE 205 206
 GOLDSTAR 210 216 225
 HARMAN KARDON 227

JVC 212
 LG 201 210 216 225
 MAGNAVOX 213
 MARANTZ 224
 MITSUBISHI 202
 NAD 223
 ONKYO 208 217

PANASONIC 203 209
 PHILIPS 213
 PIONEER 204 226
 PROCEED 221
 PROSCAN 205 206
 RCA 205 206
 SAMSUNG 211 215

SONY 207
 THOMPSON 205 206
 TOSHIBA 219 208
 YAMAHA 209 218
 ZENITH 210 216 225

Cable Boxes

ABC 003 004 039 042 046
 052 053
 ANTRONIK 014
 ARCHER 005 007 014 024
 CABLE STAR 026
 CENTURION 092
 CENTURY 007
 CITIZEN 007
 COLOUR VOICE 065 090
 COMBANO 080 081
 COMTRONICS 019 030
 DIAMOND 023
 EAGLE 020 030 040
 EASTERN 057 062 066
 ELECTRICORD 032
 GE 072

GEMINI 008 022 025 054
 GI 052 074
 GOLDEN CHANNEL 030
 HAMLIN 049 050 055
 HITACHI 052 055
 HOSPITALITY 070 077
 JERROLD 002 003 004 008 009
 010 052 069 074
 LG 058 101
 M-NET 037
 MACOM 033
 MAGNAVOX 010 012 064 079
 MEMOREX 001
 MOVIE TIME 028 032
 NSC 015 028 038 071 073
 OAK 016 031 037 053
 PANASONIC 044 047
 PARAGON 001

PHILIPS 006 012 013 020 065
 085 090
 PIONEER 034 051 052 063 076
 POST NEWS WEEK 016
 PRUCER 059
 PTS 011 048 071 072 073
 074
 PULSAR 001
 RCA 047
 REGAL 049 050
 REGENCY 057
 REMBRANT 025
 RK 091
 SAMSUNG 030 061 068 083
 SCIENTIFIC ATLANTA 003 011 041
 042 043 045 046
 SHERITECH 022
 SIGNAL 030

SIGNATURE 052
 SL MARX 030
 SPRUCER 047 078
 STARCOM 002 004 008 009
 STARGATE 008 030
 SYLVANIA 067
 TADIRAN 030
 TANDY 017
 TEXSCAN 029 067
 TOCOM 039 040 056
 TOSHIBA 001
 UNIKA 007 014 024
 UNITED CABLE 004 053
 UNIVERSAL 005 007 014 024 026
 027 032 035
 VIEWSTAR 012 015 018 086 087
 088 089
 ZENITH 001 021 060 093

Cable Satellite

ALPHASTAR DSR 233
 AMPLICA 160
 BIRDVIEW 161 236 239
 BSR 163
 CAPETRONICS 163
 CHANNEL MASTER 123 124 125
 128 146 165
 CHAPARRAL 118 119 122 187
 CITOH 164
 CURTIS MATHES 160 228
 DRAKE 115 116 117 120
 121 162 222 226
 183
 DX ANTENNA 134 156 166 186
 ECHOSTAR 148 150 167 168
 203 204 205 206
 207 208 209 210

232
 ELECTRO HOME 199
 EUROPLUS 224
 FUJITSU 127 131 132 137
 243 244
 GENERAL INSTRUMENT 113 114 126
 139 141 169 211
 HITACHI 144 177
 HOUSTON TRACKER 143 147 149
 161 167 214
 HUGHES 178
 HYTEK 163
 JANIEL 170 241
 JERROLD 171
 KATHREIN 218
 LEGEND 167
 LG 249
 LUTRON 242
 LUXOR 172 223

MACOM 120 169 173 174
 175
 MEMOREX 167
 NEXTWAVE 138 234 235
 NORSAT 179 180
 PACE SKY SATELLITE 219
 PANASONIC 170 202
 PANSAT 231
 PERSONAL CABLE 227
 PHILIPS 181
 PICO 215
 PRESIDENT 129 212
 PRIMESTAR 140 220 221
 PROSAT 182
 RCA 176 216
 REALISTIC 153 184
 SAMSUNG 233
 SATELLITE
 SERVICE CO 138 145 157 167

195
 SCIENTIFIC
 ATLANTA 142 248
 SONY 213
 STARCAST 151
 SUPER GUIDE 130 234 235
 TEECOM 133 136 185 197
 198 200 217 240
 247
 TOSHIBA 112 237
 UNIDEN 126 135 152 153
 154 155 158 159
 188 189 190 196
 211
 UNIDEN 245 246
 VIEWSTAR 225
 WINEGARD 238 229
 ZENITH 111 191 192 193
 194 201 230

AUX Audio

GOLDSTAR 005
 HITACH 010
 JVC 006 039 049 050
 KENWOOD 001 013 029 031
 044

LUXMAN 017
 MARANTZ 002 021 028 030
 032 035
 NAD 014
 NAKAMICHI 051 052
 ONKYO 008 009 025 040
 041

OPTIMUS 011 013 022
 PANASONIC 003 015 036 046
 PIONEER 007 016 020 023
 024 026 033 037
 047
 QUASAR 003 036
 RCA 004

SHARP 013 029 043 045
 SHERWOOD 012 019
 SONY 027 034 038 048
 053
 SOUNDESIGN 018
 TOSHIBA 042
 VICTOR 006 039

Audio CD Players

ADC 104
 AIWA 149 178 189 202
 212
 AKAI 134 165 200
 DENON 101 190 221 222
 223
 EMERSON 133 136 152 166
 175
 FISHER 113 122 138 140
 168
 GE 209
 HITACHI 133 166
 JVC 117 196 227 228
 KENWOOD 105 110 113 118

144 154 155 198
 200 216 217
 LUXMAN 108 123 153 173
 MAGNAVOX 127 135 172 179
 180
 MARANTZ 129 135 141 159
 224 225 226
 MCS 111 147 156 169
 MITSUBISHI 120 179 229 230
 231
 ONKYO 125 126 130 131
 213 215 232
 OPTIMUS 100 107 110 124
 139 140 145 146
 162 163 164 165

170
 PANASONIC 106 151 176 184
 203 219 233
 PHILIPS 127 135 195 199
 237
 PIONEER 107 124 167 171
 179 187 191 205
 206 207
 QUASAR 106 176
 RADIO SHACK 186 188
 RCA 114 133 157 166
 114
 SANYO 121 140 158 168
 SEARS 147
 SHARP 110 141 150 181

200 204 210 150
 217
 SHERWOOD 102 115 116 128
 141 193
 SONY 100 142 168 174
 182 183 192 208
 234 235 236
 TECHNICS 106 148 151 176
 184 203 214 218
 TEAC 103 112 132 141
 160 161 132 177
 185 161 197 201
 YAMAHA 109 119 137 143
 194 211

Remote Key Functions By Mode

Key functions list for your remote control

KEY NAME	TV Mode Zenith Code 101	VCR Mode Zenith Code 201	Cable Mode Zenith Code 353	AUX Mode (DVD) Zenith Code 960
POWER	TV On/Off	VCR On/Off	Cable Box On/Off	AUX TV/DISC
CABLE	Selects Cable	Selects Cable	Selects Cable	Selects Cable
VCR	Selects VCR	Selects VCR	Selects VCR	Selects VCR
AUX	Selects Aux	Selects AUX	Selects Aux	Selects AUX
TV	Selects TV	Selects TV	Selects TV	Selects TV
SURF	Surf On/Off	VCR SP/EP	CABLE FC Fav Ch	AUX Audio
FLASHBK	TV Flashback	VCR Flashback	Cable Flashback	AUX Return
MUTE	TV Mute	TV Mute	TV Mute	TV Mute
CHANNEL UP	TV Channel Up	VCR Channel Up	Cable Channel Up	AUX Skip >>
CHANNEL DOWN	TV Channel Down	VCR Channel Down	Cable Channel Down	AUX Skip <<
VOLUME (RIGHT)	TV Volume Louder	TV Volume Louder	TV Volume Louder	TV Volume Louder
VOLUME (LEFT)	TV Volume Quieter	TV Volume Quieter	TV Volume Quieter	TV Volume Quieter
1	TV Digit 1	VCR Digit 1	Cable Digit 1	AUX Digit 1
2	TV Digit 2	VCR Digit 2	Cable Digit 2	AUX Digit 2
3	TV Digit 3	VCR Digit 3	Cable Digit 3	AUX Digit 3
4	TV Digit 4	VCR Digit 4	Cable Digit 4	AUX Digit 4
5	TV Digit 5	VCR Digit 5	Cable Digit 5	AUX Digit 5
6	TV Digit 6	VCR Digit 6	Cable Digit 6	AUX Digit 6
7	TV Digit 7	VCR Digit 7	Cable Digit 7	AUX Digit 7
8	TV Digit 8	VCR Digit 8	Cable Digit 8	AUX Digit 8
9	TV Digit 9	VCR Digit 9	Cable Digit 9	AUX Digit 9
0	TV Digit 0	VCR Digit 0	Cable Digit 0	AUX Digit 0
ENTER	TV Enter	VCR Enter	Cable Enter	Aux Display
MENU	TV Menu	VCR Menu	Cable Menu	AUX Menu
UP ARROW	TV Select Up	VCR Select Up	Cable Up Arrow	AUX Up Arrow
DOWN ARROW	TV Select Down	VCR Select Down	Cable Down Arrow	AUX Down Arrow
LEFT ARROW	TV Adjust Left	VCR Adjust Left	Cable Left Arrow	AUX Title
RIGHT ARROW	TV Adjust Right	VCR Adjust Right	Cable Right Arrow	AUX Subtitle
QUIT	TV Menu Quit	VCR Quit	Cable Quit	AUX Resume
RATIO	TV Aspect Ratio DsplyMde	No Function	No Function	AUX Zoom
VIDEO	TV Z-Video Selection	No Function	No Function	AUX Clear
SIGNAL	TV Signal Strength	VCR VCR+	Cable Day Up	AUX Marker
AUDIO	TV Audio Selection	VCR Eject	Cable Day Down	AUX Marker Search
DASH	TV Dash “-”	VCR CM Skip	Cable Pg Up	AUX Repeat-Chap
CC	TV Closed Captions	VCR Memory	Cable Pg Down	AUX Memory
TIMER	TV Timer	VCR Timer	Cable Timer	AUX Program
SOURCE	TV Sources	TV Tuner or VCR Tuner	Cable Info	AUX Open/Close
RECORD	VCR Record	VCR Record	Cable Buy	AUX Angle
PAUSE	VCR Pause	VCR Pause	Cable Guide	AUX Pause
REWIND	VCR Rewind	VCR Rewind	VCR Rewind	AUX Scan <<
PLAY	VCR Play	VCR Play	VCR Play	AUX Play
STOP	VCR Stop	VCR Stop	VCR Stop	AUX Stop/Eject
F FWD	VCR Fast Forward	VCR Fast Forward	VCR Fast Forward	AUX Scan >>

MBR4286 P124-00240 2/12



Some of the functions shown above may not be available on your equipment.

Routine TV cabinet and screen cleaning

Careful and regular cleaning can extend the the useful service life of the TV. Be sure to turn the power off and pull out the plug before you begin any cleaning.

Screen Cleaning

1. Here's a great way to keep the dust off the screen for a while. Wet a soft cloth in a mixture of lukewarm water and a little fabric softener or dish washing detergent. Wring the cloth until it's almost dry, and then use it to wipe the screen.
2. Make sure the excess water is off the screen, and then let it air-dry before turning the TV on.

Cabinet Cleaning

1. Use a soft cloth with a mild soap solution to wipe the cabinet. (Don't use any harsh, industrial strength variety of cleaner.)
2. Rinse the cloth and wipe the cabinet again.
3. Let the cabinet air-dry before turning the TV on.

Wood Cabinet

Use a quality wood cleaner and polish. This will protect the TV from dirt and dust, as well as keep the cabinet looking new.

Extended Absence

If you leave your TV dormant (Off) for a long time (such as a vacation), it's a good idea to unplug the power cord to protect against possible damage from lightning or power surges. If you use an off-air antenna, you may also want to disconnect it from the back of your TV before leaving.



If you unplug the TV, you may have to reset the clock using the Clock Set menu described earlier. See page 32.

Troubleshooting

Some quick and easy tips to resolving problems

Symptoms	Possible Cause(s)	Possible Solution(s)	See page(s)
Power			
No Power.	<ul style="list-style-type: none"> • AC Power Cord not connected. • Local power failure? 	<ul style="list-style-type: none"> -Connect power cord. Try a different household outlet. -Contact power company for information. 	8 - 14
No Source image.	<ul style="list-style-type: none"> • Source turned off. • Source not selected. 	<ul style="list-style-type: none"> -Turn Source equipment on. -Use SOURCE to choose desired picture and sound source. 	19 19
Picture Reception			
Poor or no picture.	<ul style="list-style-type: none"> • TV station problems. • Video menu not adjusted properly. 	<ul style="list-style-type: none"> -Try a different channel. -Check Video menu option settings. 	17/19 30
Local interference.	<ul style="list-style-type: none"> • Check for disturbing source. • Appliance too close to TV. 	<p><i>The following may cause image problems or distortion: Electrical appliances, powerful lights, cars, trucks; computers or portable phones; medical equipment; VCR too close to TV, etc.</i></p> <ul style="list-style-type: none"> -If possible increase the distance between your Entertainment Machine and the offending appliance. Or shut one of them off. 	
Poor or no color.	<ul style="list-style-type: none"> • Sub-standard broadcast. • Sub-standard cable signal. 	<ul style="list-style-type: none"> -Try a different channel. -Notify cable company of reception problem. 	17/19
Picture wobbles or drifts.	<ul style="list-style-type: none"> • CATV wire not connected or loose. • Local interference. • Scrambled CATV channel. 	<ul style="list-style-type: none"> -Make or tighten connection. -Try different channel. Turn off interfering appliance. -Tune to unscrambled channel. 	9/11 17/19 17/19
No CATV reception.	<ul style="list-style-type: none"> • Wrong cable band. • Cable wire not connected. • Cable service interrupted. • Antenna set, not Cable (CATV). 	<ul style="list-style-type: none"> -Try Std, HRC, IRC or contact cable company for cable band. -Connect cable service wire to Ant 1. -Contact cable service. -Select Cable in EZ Scan menu. 	18 18/9/11 18
Images in picture distorted.	<ul style="list-style-type: none"> • Wrong aspect ratio. 	<ul style="list-style-type: none"> -Use RATIO to change picture proportion. 	19/35
Poor or no sound.	<ul style="list-style-type: none"> • Audio muted. • Broadcast problem. 	<ul style="list-style-type: none"> -Press MUTE or VOL (Volume) + key to increase sound level. -Tune to a different channel. 	19 17/19
TV turns On.	<ul style="list-style-type: none"> • On-Timer turned TV On. 	<ul style="list-style-type: none"> -Cancel On-Timer and/or turn TV off. 	33
TV turns Off.	<ul style="list-style-type: none"> • Sleep Timer turned TV Off. • Off-Timer turned TV off. 	<ul style="list-style-type: none"> -Turn TV back on. -Cancel Off-Timer and /or turn TV off. 	34 33
No Closed Captions or Text.	<ul style="list-style-type: none"> • Not available on show. • Not turned on. 	<ul style="list-style-type: none"> -Check local TV listings to see if available on broadcast. -Relocate over-the-air antenna. -Try a different channel with Closed Captions or Text. -Pick a Closed Caption or Text option and turn Captions on. 	17/19 36
Lock (Parental Control) Problems			
Block appears on screen.	<ul style="list-style-type: none"> • Viewing is restricted by Lock. • Don't know password. 	<ul style="list-style-type: none"> -Key-in password and turn Lock On/Off (Restrictions) off. Set individual restriction options in Lock menu to Off. -Set Lock On/Off option to Off in Lock menu. -Tune to channel without Lock "Content" restrictions. 	39/40/41 17/19

Some quick and easy tips to resolving problems

Symptoms	Possible Cause(s)	Possible Solution(s)	Page(s)
Using Remote Control			
Remote does not work.	• Wrong mode selected.	-Press correct mode key to change mode (TV for TV operation.)	19
	• Not aimed at remote sensor.	-Point remote at Front Control Panel.	17
	• Remote too far from TV or too much light in room.	-Move remote closer to TV or darken room.	
	• IR path to TV interrupted.	-Remove obstructions.	
	• Weak batteries.	-Replace batteries.	8
	• Wrong battery polarity.	-Check that "+" and "-" match in battery compartment.	8
Remote does not operate accessory product.	• Product Mode not programmed. • Product not IR controlled.	-Program for other equipment: VCR, AUX, etc. -Remote only controls IR equipment.	42-48
Menu Operation			
Menu options can't be changed or selected.	• Software lock-up.	-Unplug power cord for 5 minutes to unlock software. (Reset clock if necessary.)	8
Timers do not work.	• Clock not set.	-Set clock.	32
Clock is set, or sets itself, to Wrong Time			
Clock time is wrong.	• Wrong Time Zone.	-Reset to your time zone.	32
	• Daylight Savings Time wrong.	-If not observed in your area, set to Off.	32
	• Time does not set automatically.	-Set clock manually, or try tuning to PBS station.	32
	• Auto Mode doesn't work.	-Set PBS station on Clock menu.	32
	• Auto Clock doesn't work.	-Turn Auto Clock option "Off" in menu, set clock manually.	32
Picture Viewing Problems			
Image looks wrong.	• Wrong Aspect Ratio.	-Use correct aspect ratio for source's image.	35
Snowy or Poor Picture	• Wrong Ant. connection/location.	-Move antenna, check connection/location. -Check cable input.	
	• TV/VCR button set wrong.	-Set TV/VCR button on your VCR correctly.	10/11
	• Wrong tuning mode.	-Are you in TV or cable tuning mode, and should be in the other?	
	• Wrong output channels selected.	-Make sure output channels tuned on all A/V equipment are on the same channel (3 or 4).	10/11
	• Loose connection.	-Check that all connections are tight.	
Picture has a big black box on it, but the sound is O.K.	• Caption/Text mode turned on.	-The CC (closed caption) option may be in Text 1, 2, 3, or 4 mode. -Select CC 1, or OFF in the Caption/Text menu.	36
No picture.	• AC power not plugged in?	-Plug AC power cord in.	8
	• AC power outlet doesn't work.	-Check that your AC power outlet works. (Test it by plugging in something else or try another outlet.)	
	• Menu options set wrong.	-Make sure brightness controls are set properly.	30
	• Broadcast problem.	-Try another channel.	17/19

Troubleshooting (Continued)

Symptoms	Possible Cause(s)	Possible Solution(s)	Page(s)
----------	-------------------	----------------------	---------

Sound/Audio Problems

Normal picture but no sound.	<ul style="list-style-type: none">• Check volume levels.• Try another channel.• A/V cables incorrectly connected.• Audio Out cables installed wrong.• Speakers turned off.• No SAP signal.	<ul style="list-style-type: none">-Make sure the TV sound is not muted.-The problem may be the broadcast, not your TV.-Install the Audio cables correctly.-Install external amplifier cables correctly.-Turn speakers on in the Audio menu.-If the Audio Mode is set to SAP, the channel may not have an SAP program.	19 17/19
------------------------------	---	--	-------------

HD/DVD Problems

Picture looks wrong.	<ul style="list-style-type: none">• Wrong Aspect Ratio.	<ul style="list-style-type: none">-Use correct aspect ratio for source's image.	35
No picture or sound.	<ul style="list-style-type: none">• Wrong source selected on TV.• Source equipment turned off.• Tape or Disk not playing.• Wires incorrectly connected.	<ul style="list-style-type: none">-Select correct source equipment.-Turn source equipment on.-Press "PLAY" on source equipment.-Install wires correctly on TV and equipment.	19 8 - 14
No HD-IN sound.	<ul style="list-style-type: none">• Audio cables not connected to HD-In R-L Audio.	<ul style="list-style-type: none">-Connect audio cables to HD-In R-L Audio.	14
A distorted, dark double image appears on the screen.	<ul style="list-style-type: none">• A progressive source is connected to the HD IN/DVD IN jacks.	<ul style="list-style-type: none">-Switch your DVD player or set-top box to interlaced.	13/14

Digital Audio Optical Problems

No sound.	<ul style="list-style-type: none">• Wrong sound source selected on audio equipment.• No audio optical connections.	<ul style="list-style-type: none">-Select TV input source on audio equipment.-Connect audio optical cable to TV and audio equipment.	16
-----------	---	---	----

A list of definitions for some of the words found in this guide

75 OHM RF CABLE	The wire that comes from an off-air antenna or cable service provider. The end looks like a hex-shaped nut with a wire sticking through the middle. It screws onto the threaded jack on the back of the TV.
300 TO 75 OHM ADAPTER	A small device that connects a two-wire 300 ohm antenna to a 75 ohm RF jack. They are usually about an inch long with two screws on one end and a round opening with a wire sticking out on the other end.
A/V CABLES	Audio/Video cables. Three cables bunched together—right audio (red), left audio (white), and video (yellow). A/V cables are used for stereo playback of videocassettes and for higher quality picture and sound from other A/V devices.
A/V DEVICE	Any device that produces video or sound (VCR, DVD, cable box, or television).
ADDED	Lets you add new channels to channel scan list that you'll scroll through.
AMPLIFIER	An electronic device that amplifies sound from a television, CD player, VCR, DVD or other A/V equipment.
ANALOG	Standard channel broadcast format. Usually identified as UHF and VHF.
ANTENNA	The physical receiver of television signals sent over the air. A large metal piece of equipment does not always have to be visible for your home to be using an antenna.
DELETED	Lets you remove channels from the channel scan list that you'll scroll through.
DTV	Digital TV. Digital channels are usually identified with dash "-" numbers: 9-1, 9-2, etc. if active.
EZ SCAN	Channel search; automatically finds the active channels available in your area.
INPUT	Refers to the jack that receives a signal from a TV, VCR or other A/V device.
JACK	An input or output connection on the back of a TV, VCR, or other A/V device.
MONO SOUND	Mono (monaural) sound is one channel of sound. With more than one speaker, all the speakers play the same audio.
OUTPUT	Refers to the jack that sends a signal out of a VCR, DVD, or other A/V device.
2ND AUDIO PROGRAMMING/SAP	Second Audio Programming (SAP) is another, separate, audio channel available with some programming. Choosing SAP often refers to listening to audio in another language, such as Spanish or French.
SIGNAL	Picture and sound traveling through a cable, or over the air, to your television screen.
STEREO SOUND	Stereo (Stereophonic) sound refers to audio that's divided into right and left sides.
TUNER	Device that picks up the signal and turns it into picture and sound.

Zenith TV Models: C32V23•C36V23•C34W23 Warranty



Zenith will repair or replace your product, at Zenith's option, if it proves to be defective in material or workmanship under normal use, during the warranty period listed below from the date of original consumer purchase. **This warranty is available only to the original, end user purchaser of the product and effective only when used in the United States, excluding U.S. Territories. Zenith is not responsible for deinstallation or reinstallation of unit.**

WARRANTY PERIOD:		HOW SERVICE IS HANDLED:
Labor:	90 Days from date of purchase.	In-Home service: Please retain your bill of sale for proof of warranty. Please call 1-877-9Zenith (1-877-993-6484) to locate your nearest Zenith Authorized Service Center. Repair parts or a replacement may be new or remanufactured. Please see below for further information.
Parts:	One Year from the date of purchase. Picture tube two years.	

THIS WARRANTY IS IN LIEU OF ANY OTHER WARRANTY, EXPRESSED OR IMPLIED, INCLUDING WITHOUT LIMITATION, ANY WARRANTY OF MERCHANTABILITY OR FITNESS FOR A PARTICULAR PURPOSE. TO THE EXTENT ANY IMPLIED WARRANTY IS REQUIRED BY LAW, IT IS LIMITED IN DURATION TO THE EXPRESSED WARRANTY PERIOD ABOVE. ZENITH WILL NOT BE LIABLE FOR ANY INCIDENTAL, CONSEQUENTIAL, INDIRECT, SPECIAL OR PUNITIVE DAMAGES OF ANY NATURE, EVEN IF ADVISED OF THE POSSIBILITY OF SUCH DAMAGES, INCLUDING WITHOUT LIMITATION LOST PROFITS, LOST OR CORRUPTED PROGRAMMING OR DATA, OR ANY OTHER DAMAGE WHETHER BASED IN CONTRACT, TORT OR OTHERWISE. Some states do not allow the exclusion or limitation of incidental or consequential damages or limitations on how long an implied warranty lasts, so the above exclusion or limitation may not apply to you. This warranty gives you specific legal rights and you may also have other rights that vary from state to state.

THIS LIMITED WARRANTY DOES NOT APPLY:

- To damages or operating problems that result from shipping, installation, adjustment of user controls, calibration, maintenance or failure to maintain, or separate system components.
- To damages or operating problems that result from normal wear and tear, misuse, abuse, operation outside environmental specifications or contrary to the requirements and precautions in the Operating Guide, accident, lightning strikes or other natural causes, modification or alteration, incorrect electrical current or voltage, signal reception or input, computer software, or institutional or commercial use.

Therefore, you pay for the cost of repair or replacement under these circumstances.

CUSTOMER ASSISTANCE NUMBERS:

To prove warranty coverage:

Retain your dated sales receipt to prove date of purchase. Legible copy of your sales receipt must be submitted at the time warranty service is provided.

To obtain where-to-buy, nearest Authorized Service Center, product assistance or customer assistance:

Call 1-877-9Zenith (1-877-993-6484) (Mon. - Fri. 7:00 AM to 8:00 PM and Sat. 8:00 AM to 5:00 PM CT)
Please select the appropriate option from the menu.