

User Manual

UHF RFID Integrated Machine

Version: 1.0

Date: September 2017

1. Product Summarize

U1000E, U1000F, U2000E, U2000F is a new generation of RFID UHF series products for our company's independent research and development of the long distance RFID Integrated Machine in the parking lot and access control system.

The product uses the industry's most cost-effective UHF card reader chip, and the part of swing card adopts the module integrated design, making the product to meet the technical requirements of the parking lot and access control system. Meanwhile, the utility model has the advantages of stable reading performance, good consistency, low working current and temperature, long service life, and small external influence, and the product adopts the waterproof outer shell design.

The product is also a fully meet the CE, FCC technology requirements of the product, and to obtain CE, FCC and other security certification.

2. UHF RFID Integrated Machine

I Overview:



Dimension
250mm*250mm*70mm (U1000E,
U1000F)
445mm*445mm*70mm (U2000E,
U2000F)

I Lateral View and Interface:

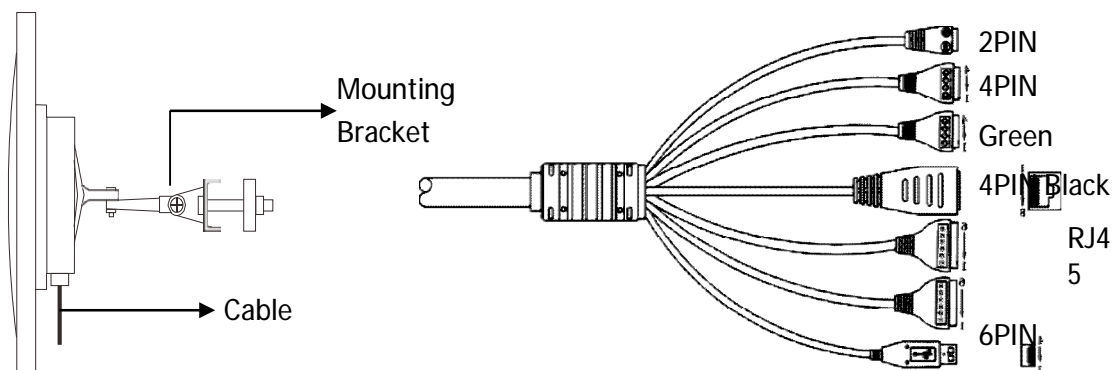

Cable Definition:

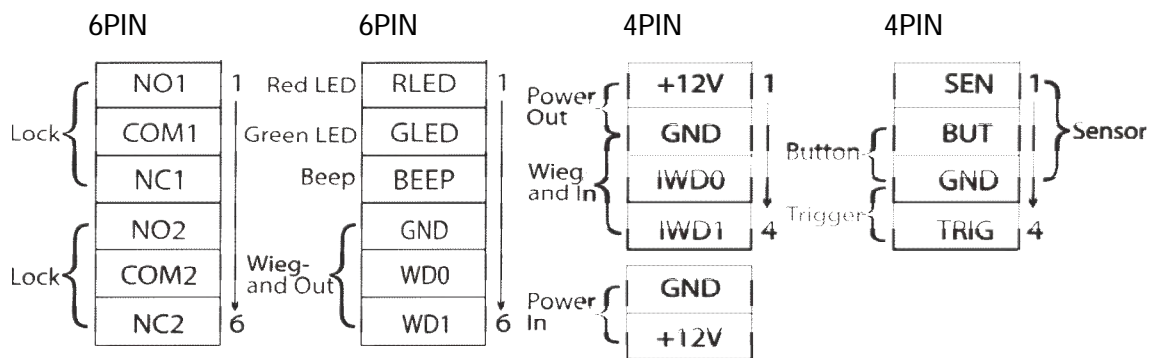

3. Parameters Specifications

Model	U1000E, U1000F	U2000E, U2000F
Logo&Color	ZKTeco logo, black (standard)/White logo, white(optional)	
Card Capacity	5000 cards	
Log Capacity	30,000 Transactions	
Reading Distance	0-6m(Stable is 0-5meters)	0-12m(Stable is 0-10meters)
Communication	TCP/IP ,USB,Wiegand26/34	
Access Control Interface	3rd Party Electric Lock, Door Sensor, Exit Button, Alarm	
Wiegand Signal	Wiegand input & output	
Working Frequency	F:902Mhz-928MHz; E:865MHz-868MHz	
Support Card	Tag1,Tag2,Tag3,Tag4,DF01Card,DF02 Card	
UHF Interface Protocol	EPC global UHFClass1Gen2/ISO18000-6c	
Antenna Gain	6dBi	6dBi
Maximum power consumption	<2W(RF output 26dBm,single tags)	
Ingress Protection Rate	IP 66	
Supporting Software	ZKAccess3.5;ZKBiosecurity3.0	
Working Voltage	DC 9V-12V	
Working Current	150mA (always reading)	
Working Temperature	-20°C--+60°C	
Working Humidity	<95% (25°C)	
Dimension	250mm*250mm*70mm(±5)	445mm*445mm*70mm(±5)

4. Safety Precautions

- 1) The integrated machine working voltage ranges from DC9V to DC16V, it is recommended to use DC12V /3A power supply.
- 2) Please wire according to the cable definition.

5. Modifying Setting via Demo

- 1) USB Connection

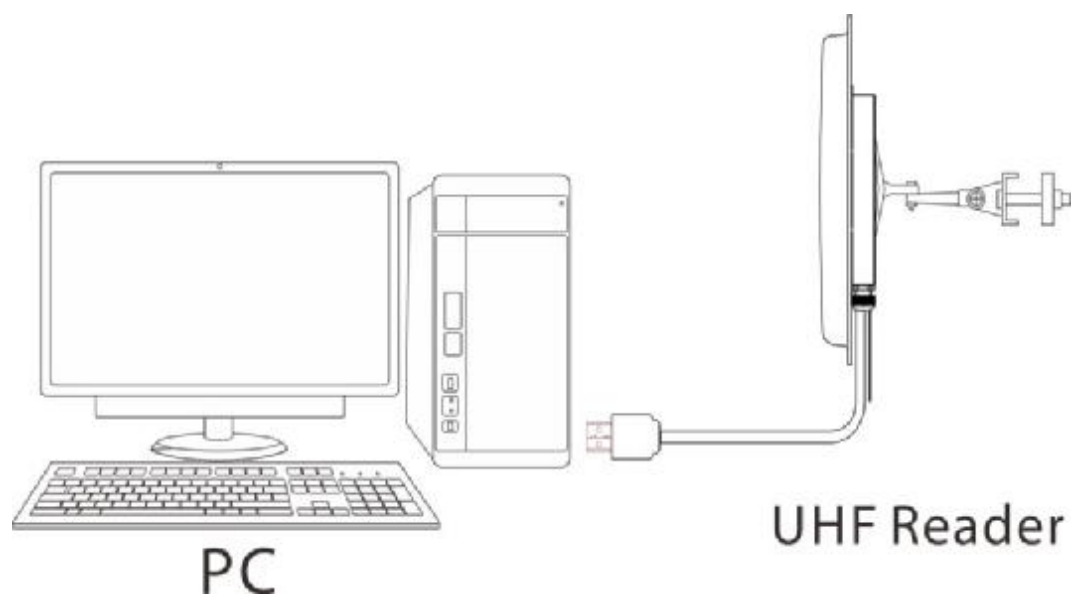

- 2) Software Introduction

Our company provides Demo, used to set the working parameters of the integrated machine. Demo interface as shown below:

The default configuration of the integrated machine is as follows:

Work Mode	Always Read
Read Tag Interval Time	0s (Default)
Wiegand Out Setting	wiegand 26; Forward Output; 9th Start Byte(Default);
Wiegand Interval Time	2s (Default)
Working Frequency	902MHz ~928MHz (American Standard); 865MHz ~ 868MHz (European standard)

Demo Using Instructions:

- Ø Connect the USB port of the integrated machine to the USB port of the computer.
- Ø The power adapter is recommended to use the DC12V/3A specification. Power supply to the integrated machine and the buzzer sounds once.
- Ø In the computer to open Demo, click 'Connect', on the right side of the middle will show 'Connect Successful' , and machine and demo connectionsuccess.
- Ø Wiegand Interval Time: Sets the time interval between adjacent wiegand data.
- Ø Reader Indicate: Set whether the buzzer rings when the machine is on the electricity and brush the card.
- Ø Work Mode: Set the working mode of the machine, and including always read mode, trigger mode. Under trigger mode, time of reading card can be set when it is triggered once.
- Ø Wiegand Setting: Set the machine's wiegand output format.

- Ø Setting Wiegand Out Bytes: Sets the forward or reverse output of the machine's Wiegand Data, and start output from the first few bytes.
- Ø Read Tag Interval Time: Set the machine to read the card interval. Read card interval is the time when from the card is read within the scope of the card to the card is left out of the scope of the card to read the second time card.

6. Access to Software

RJ45 Connection

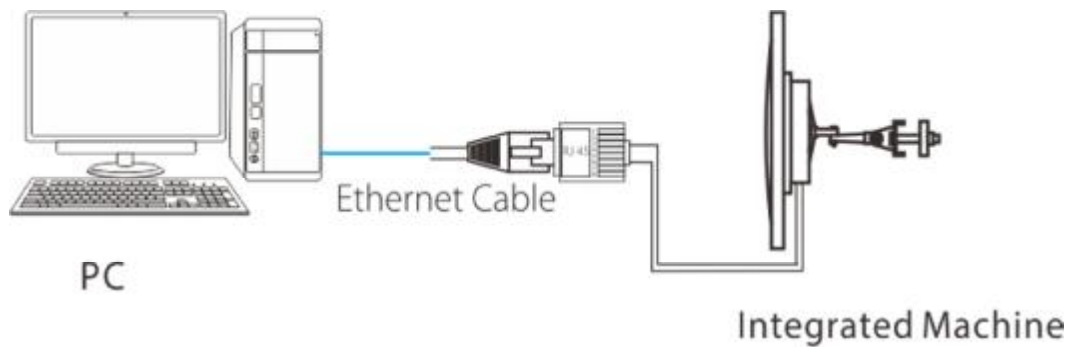

Connect the RJ45 port of the integrated machine to the Ethernet port of the computer. The machine supports access to ZKAccess 3.5.3 build 0009 and ZKBioSecurity 3.0.5.0 software.

6.1. Access to ZKAccess

1) Add Device:

- Ø Search the integrated machine

Click [Device] > [Search Panels], click [Start Search] to search the integrated machine by TCP/IP.

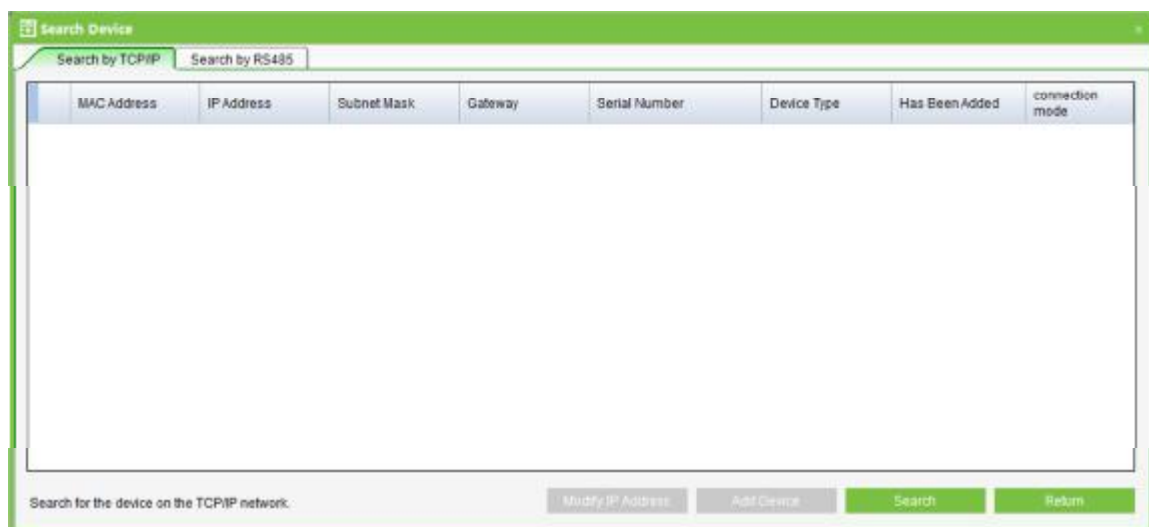

Ø Add Device

After searching, select the integrated machine and click [Add Device], and a dialog box will open. Enter self-defined device name, device type set to Standalone Device and click [OK] to complete device adding.

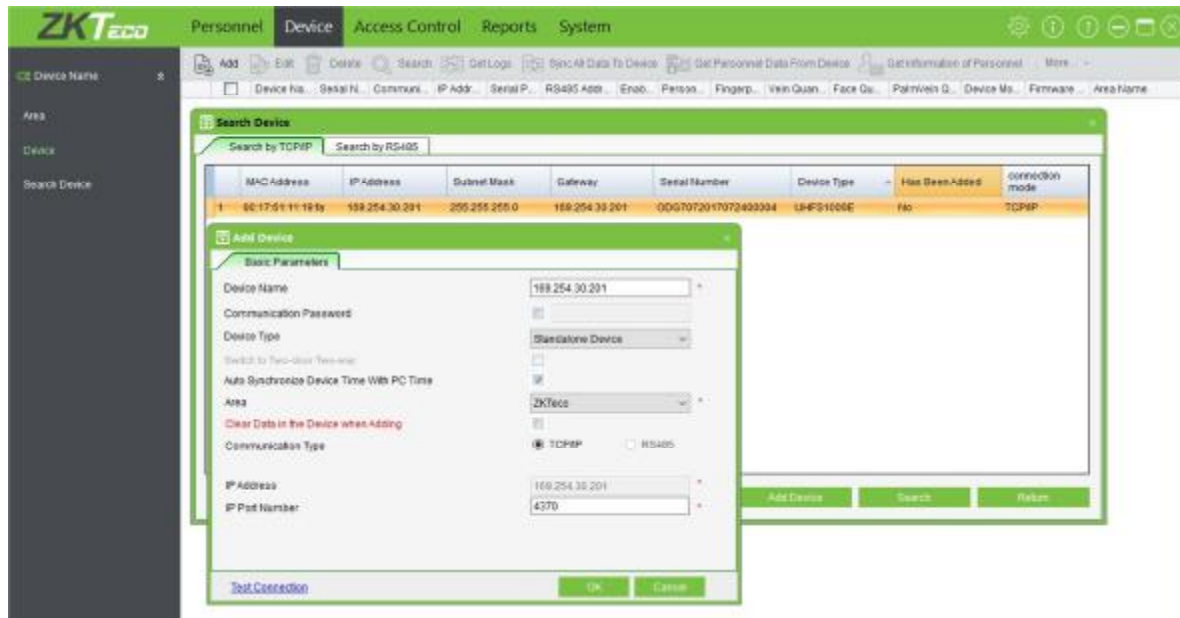

Note: The default IP address of the integrated machine may conflict with the IP of a device on the Internet. You can modify its IP address: Click [Modify IP Address] behind the device and a dialog box will open. Enter the new IP address and other parameters (Note: Must configure the gateway and IP address in the same network segment).

2) Register the UHF tag

Connect the UHF Card Issuer to a computer; click the Personnel Profile tab to register the UHF tag, as shown in the figure below:

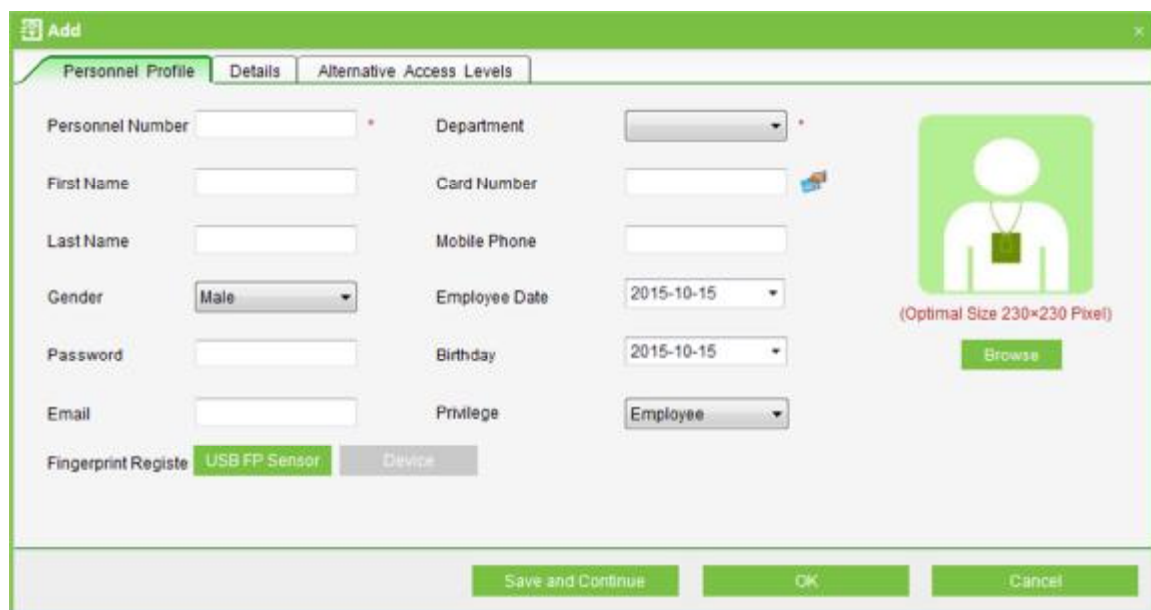

3) Set Access Control Parameters

The Access Control Parameters include time zones, holidays, door settings, access levels, anti-passback, personnel group, multi-card opening and so on. For more details about how to set the access control parameters, please see the software user manual.

4) Sync All Data to Device

Select device, click [Synchronize All Data] and click [OK] to complete synchronization. The system will synchronize the data to the device, including door information, access control levels (personnel information, access control time zones), anti-pass back settings, interlock settings, linkage settings, first-card normal open settings, multi-card normal open settings and so on.

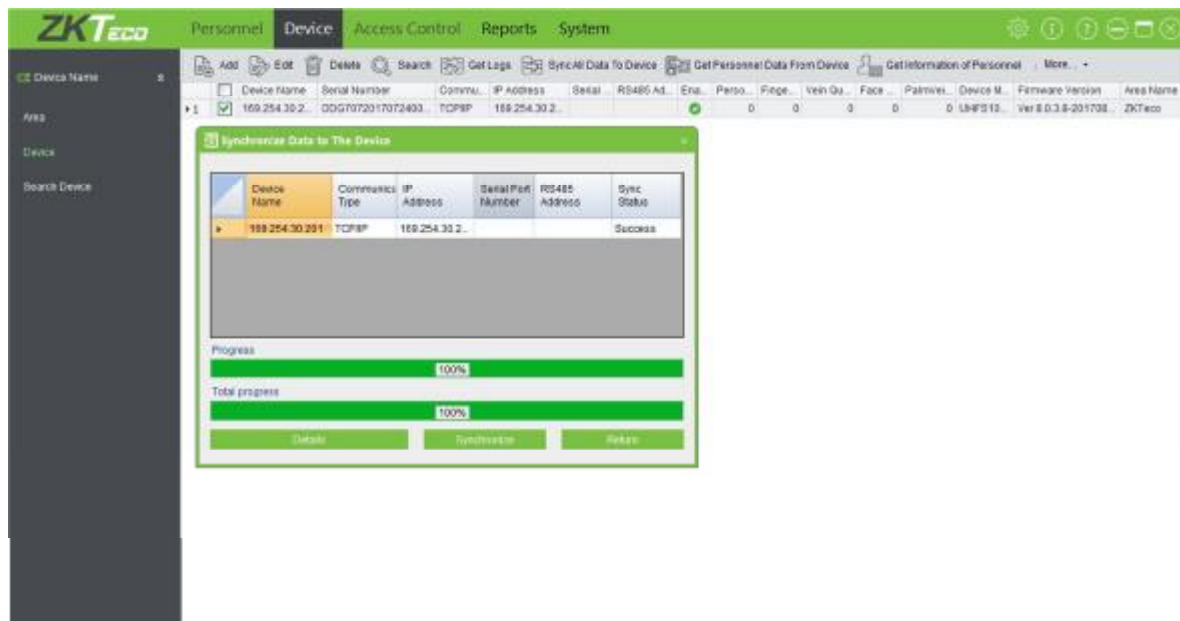

5) Real-time Monitoring

Monitor the statuses and real-time events of doors under the access control panels in the system in real-time, including normal events and exceptional events (including alarm events).

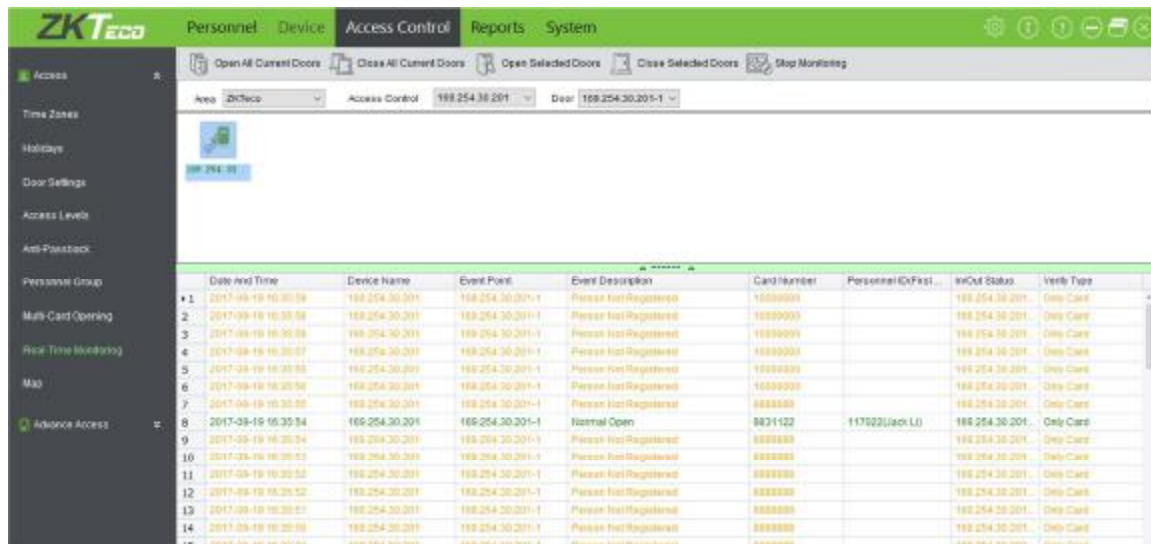

6.2. Access to ZKBioSecurity

The procedure to access to ZKBioSecurity is basically the same as [6.1. Access to ZKAccess](#); for more details, please see the software user manual.

7. Solution

1) Long Distance Access Control Management

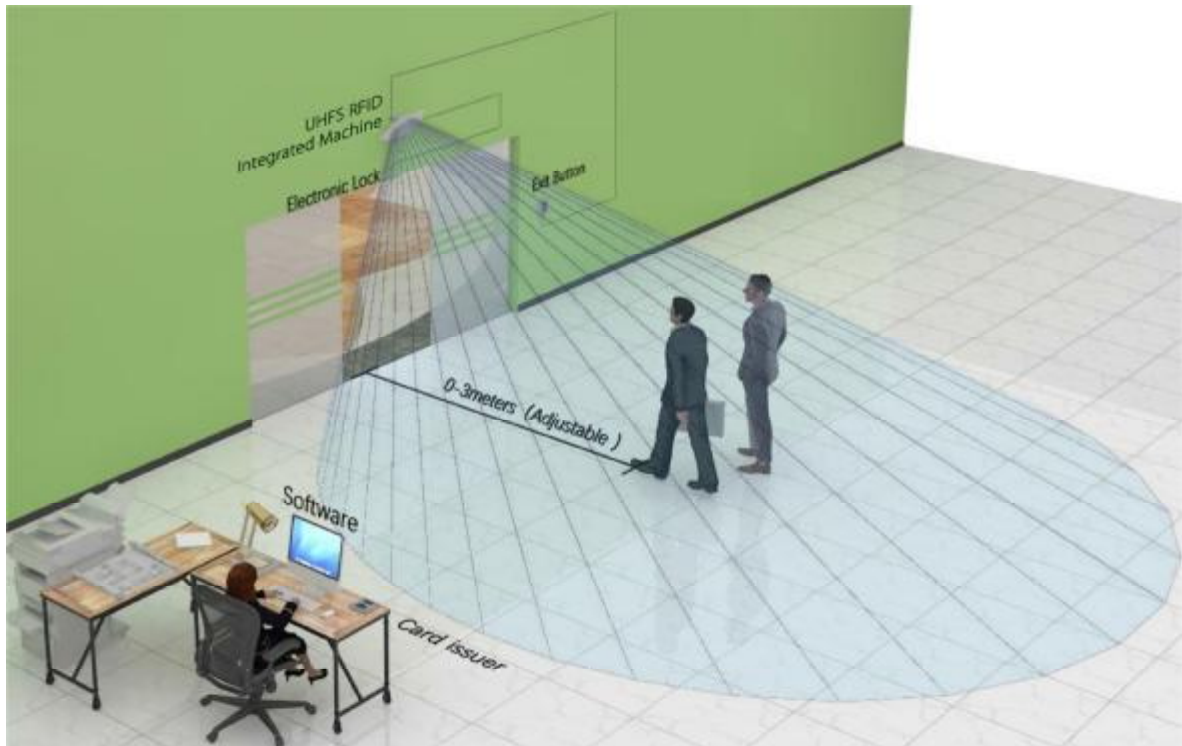

Compared with the traditional access control close proximity recognition mode, long distance access control gets rid of the passive recognition of the shackles, really realize the "Hand Free" model. Remote sensing, automatic reading card, automatic identification, will greatly improve the convenience of personnel access.

The long distance access control system consists of U1000 series integrated machine, UHF tag1, tag2 or DF cards, UR10Rseries card issuer, electronic lock and door.

2) The Long Distance Fixed Vehicle Access Management for Parking Lots

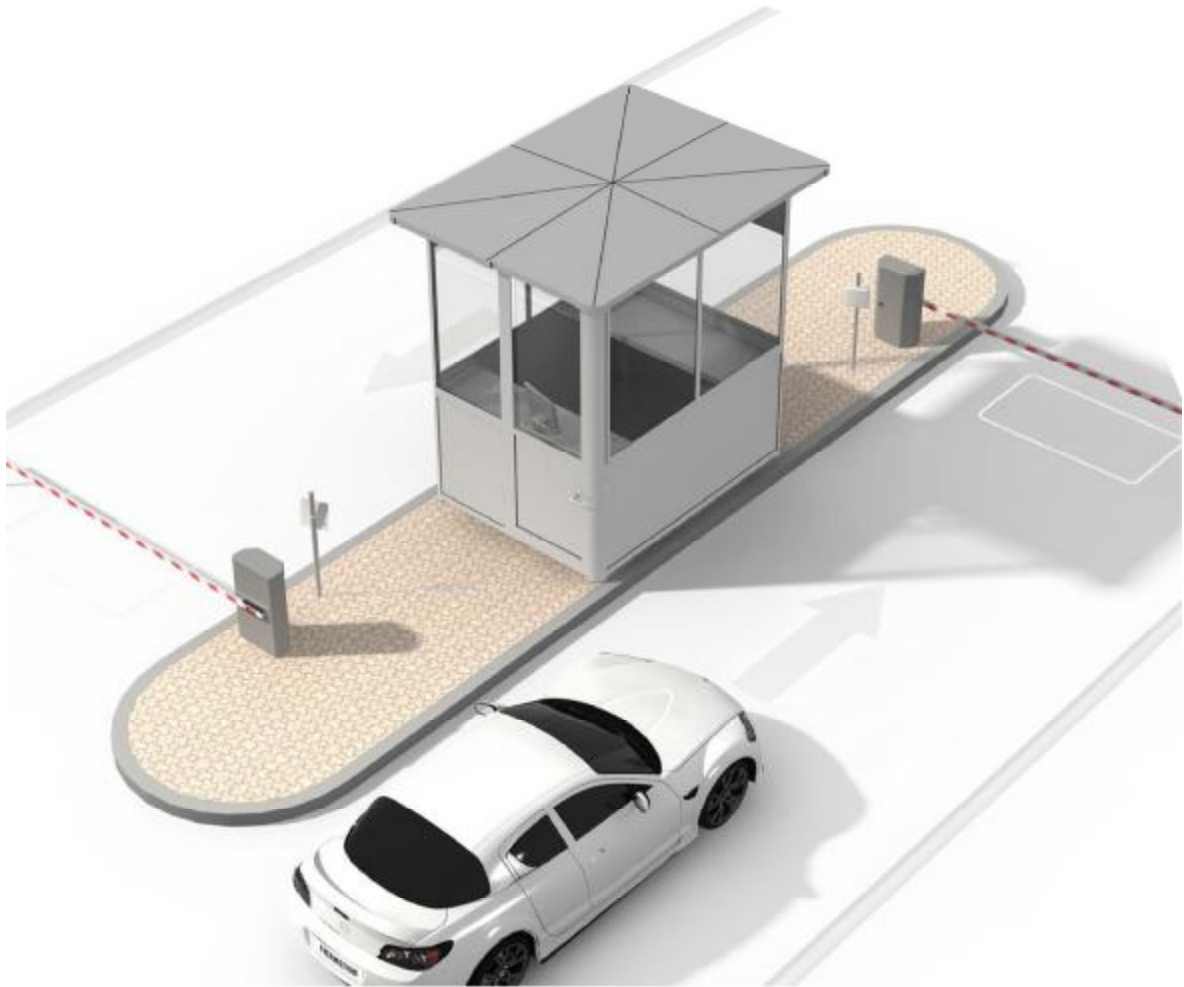

This solution provide user with a non-stop, no card, quick access to parking lots experience. The system consists of U2000 series integrated machine, UHF tag3 (installed on the upper or lower edges of the license plate) or tag4 (pasted on the interior windshield of car), and parking barrier.

When the car pulls up the range of the U2000 integrated machine, the authorized tag mounted on car will be identified, then reading information is transmitted to the integrated machine, after identification correctly, integrated machine outputs an "open" signal to the barrier, then the gate is open. At last, the car can easily have access to parking lots.

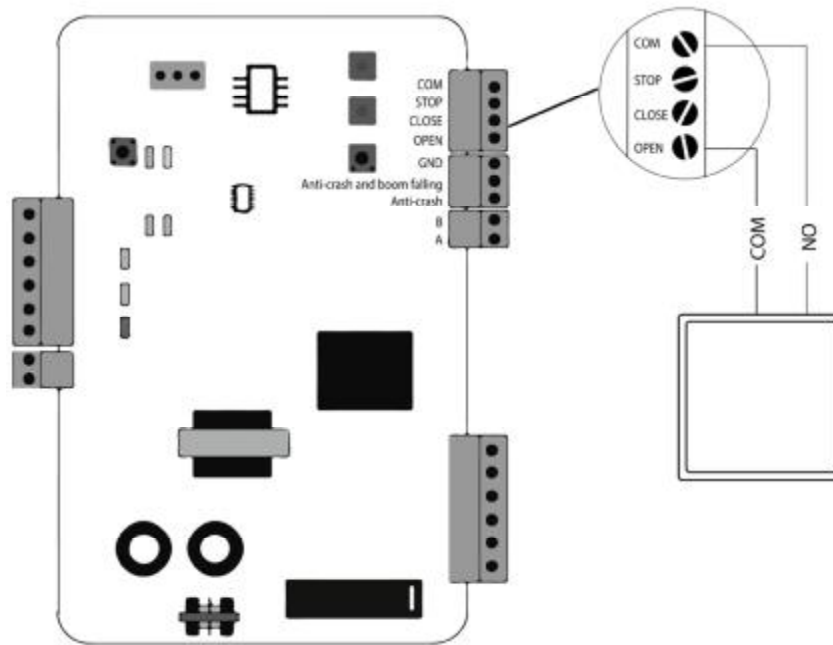

U2000 integrated machine connect with parking barrier

8. Note

- Ø The integrated machine cannot be installed in a high-voltage environment, for example, high tension wires and high-voltage transformers.
- Ø The integrated machine cannot be installed near strong magnetic field.
- Ø If the integrated machine is installed at a T-junction or a 90° corner or in other unfavorable environment, the integrated machine may fail to read the card due to the overlarge reading angle. You can install an additional integrated machine at the corner to solve the problem.
- Ø For such terrains as slopes, adjust where the integrated machine faces, turning it downwards within the effective range of card reading.
- Ø Remote card reading by the UHF integrated machine is affected by the protective film (explosion-proof film) on car windows to some extent.
- Ø Remote card reading by the UHF integrated machine is affected on rainy, snowy or windy days to some extent.

Warning: Changes or modifications to this unit not expressly approved by the party responsible for compliance could void the user's authority to operate the equipment.

Note: This equipment has been tested and found to comply with the limits for a Class B digital device, pursuant to Part 15 of the FCC Rules.

These limits are designed to provide reasonable protection against harmful interference in a residential installation. This equipment generates, uses and can radiate radio frequency energy and, if not installed and used in accordance with the instructions, may cause harmful interference to radio communications. However, there is no guarantee that interference will not occur in a particular installation. If this equipment does cause harmful interference to radio or television reception, which can be determined by turning the equipment off and on, the user is encouraged to try to correct the interference by one or more of the following measures:

- * Reorient or relocate the receiving antenna
- * Increase the separation between the equipment and receiver
- * Connect the equipment into an outlet on a circuit different from that to which the receiver is connected
- * Consult the dealer or an experienced radio/TV technician for help

"This equipment complies with FCC RF radiation exposure limits set forth for an uncontrolled environment.

This equipment should be installed and operated with a minimum distance of 20 centimeters between the radiator and your body."