



ZXSDR R8881 S4200 Quick Installation Guide_R4.0_EN

Contents

ZXSDR R8881 S4200 Quick Installation Guide_R4.0_EN	1
1 Overview	3
1.1 Physical Specifications.....	3
1.2 Space Requirements.....	4
1.2.1 Recommended Installation Space.....	4
1.2.2 Minimum Installation Space.....	5
1.3 Mounting Manners	6
2 Installation Tools	7
3 ZXSDR R8881 S4200 Installing	9
3.1 Wall-mounting	9
3.2 Installing 1-2 ZXSDR R8881 S4200 on the pole	11
3.3 Installing the ODCPD1	15
4 Cable Connection	18
4.1 ZXSDR R8881 S4200 Ports	18
4.2 Connecting Cables of ZXSDR R8881 S4200 (DC Power Supply).....	20
4.2.1 Overview	20
4.2.2 Connecting the Grounding Wire	21
4.2.3 Connecting the RF jumpers	22
4.2.4 Connecting the Optical Fiber.....	23
4.2.5 Connecting the AISG Cable.....	24
4.2.6 Connecting the MON Cable.....	25
4.2.7 Connecting the Frequency Spreading Cable	25
4.2.8 Making and Installing a Power Cable	26
4.2.9 Connecting Cables of ODCPD1	29
4.3 Selecting Positions for Grounding Clips.....	31
4.3.1 Grounding Clips for Antenna Feeders	31
4.3.2 Grounding Clips for Power Cables.....	32
5 Installation Check	33

1 Overview

1.1 Physical Specifications



Item	Specifications
Dimensions (Height * Width * Depth)	215 mm (D) x 320 mm (W) x 370 mm (H)
Weight	18 kg
Rated Input Voltage	DC: -48 V (-62 V - -37 V)
Operating Temperature	-30°C to 50°C
Operating Humidity	5% - 100%
Storage Temperature	-60 °C - +70 °C
Storage Humidity	5% - 100%

1.2 Space Requirements

1.2.1 Recommended Installation Space

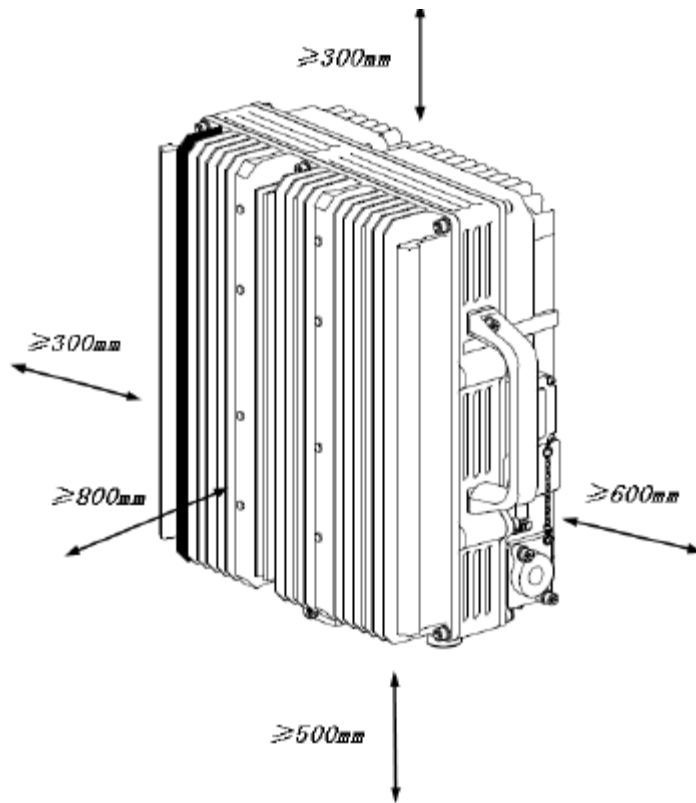

1.2.2 Minimum Installation Space

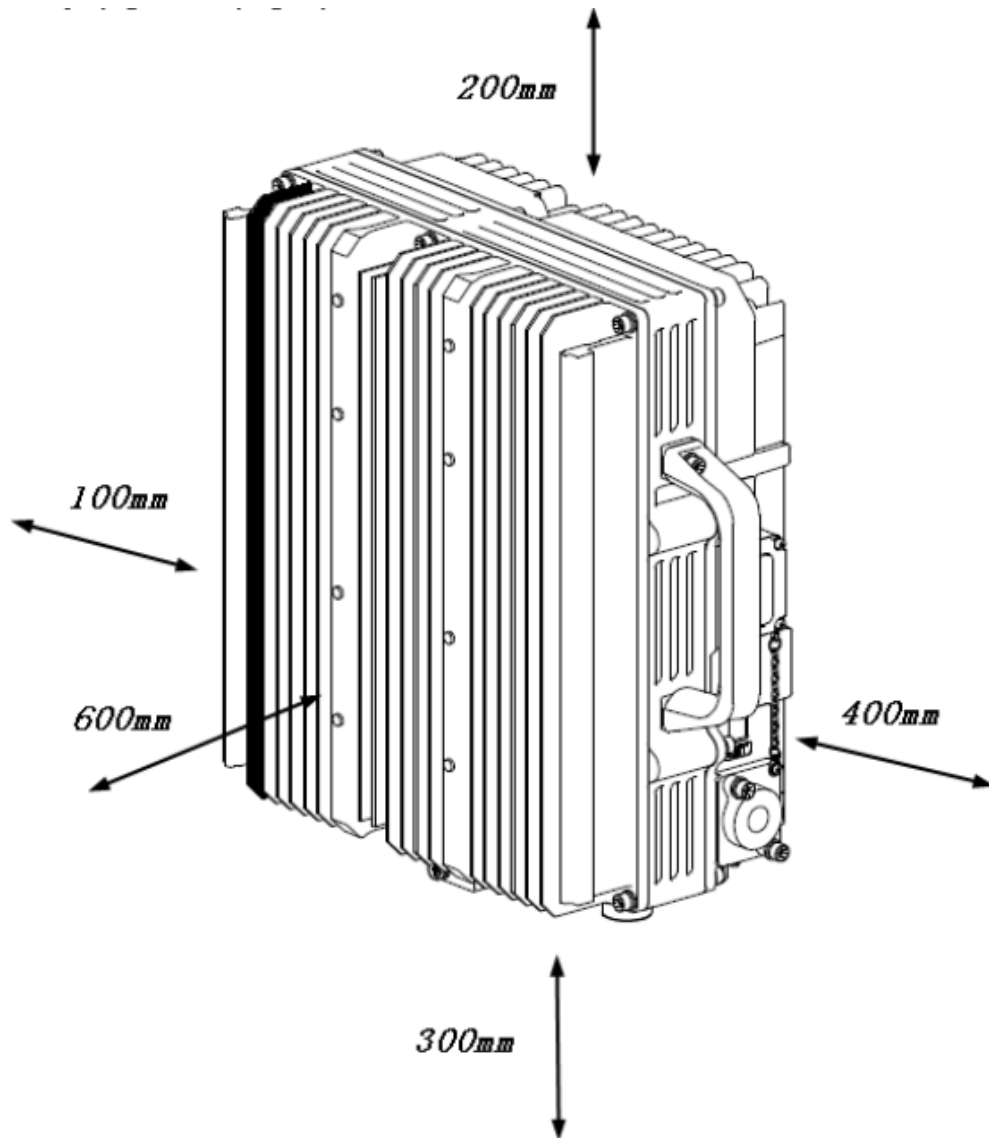

1.3 Mounting Manners



Wall-mounting



Pole-mounting

2 Installation Tools



Electrical punch drill



Earth resistance tester



Vacuum cleaner



Multimeter



Coaxial cable stripper



Power Strip



Screwdriver



Hex key wrench



Hydraulic Crimper



Wrench



Cutter



Claw hammer



Pliers



Steel tape



Spirit Level



Crimper



Safety helmet



Slip-proof glove



Hacksaw



Ladder

3 ZXSDR R8881 S4200 Installing

3.1 Wall-mounting

In most cases, two expansion bolts are enough to fasten the mounting bracket, which should pass through the upper two screw holes on the face of the bracket. However, if the ZXSDR R8881 S4200 is installed along a high-speed railway, in a tunnel or an earthquake-prone zone, four expansion bolts are required.

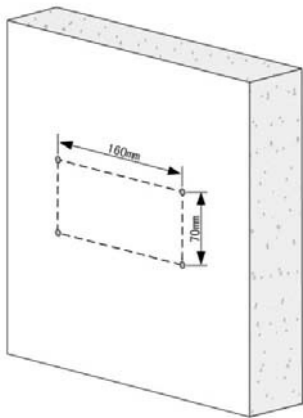

1. Use an electrical punch drill to drill 2 or 4 holes on a wall. And then fix the attachments of the expansion bolts into the holes. Use a vacuum cleaner to clean the dust while you are drilling holes
2. Place the mounting bracket on the wall. Then use two M10x100 expansion bolts to pass through the upper two screw holes on the bracket and screw up the bolts to fasten the bracket on the wall, In placing the bracket, ensure the arrow on the bracket points upward.



3. Use four M6 hexagon socket head bolts, each with a spring washer and a flat washer on, to fix the RRU support on the back of a ZXSDR R8881 S4200. 4. Remove the screw in the middle of the mounting bracket.



support into the grooves of the mounting bracket.



6. Rein in Step RRU.

3.2 Installing 1-2 ZXSDR R8881 S4200 on the pole

Note:

1. The diameter of the pole ranges from 60mm to 120 mm. If the diameter is no more than 90 mm, a pad (as shown in the left figure) should be used in tightening the bolt; otherwise, the pad is not necessary.
2. The width of the angle steel should range from 60 mm to 100 mm; and the width of the channel steel should range from 63 mm to 100 mm.

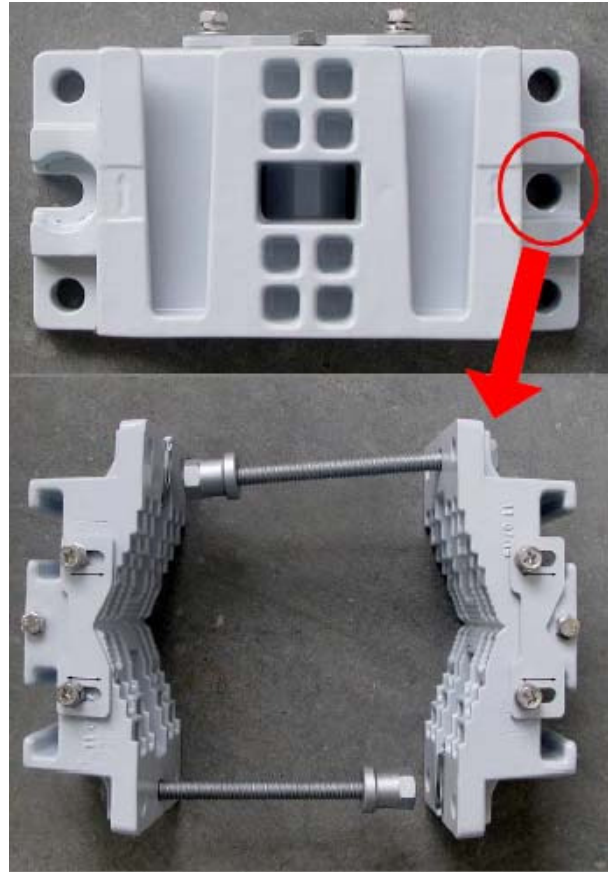

1. Put a fixed bolt through the installation holes (in the middle) of each mounting bracket.



2. Place the two mounting brackets on a pole in a back-to-back manner and put the fixed bolts into the bolt grooves on the opposite brackets.



Pole Diameter > 90 mm

Pole Diameter \leq 90 mm

3. Tighten the bolts to fix the mounting brackets on the pole.

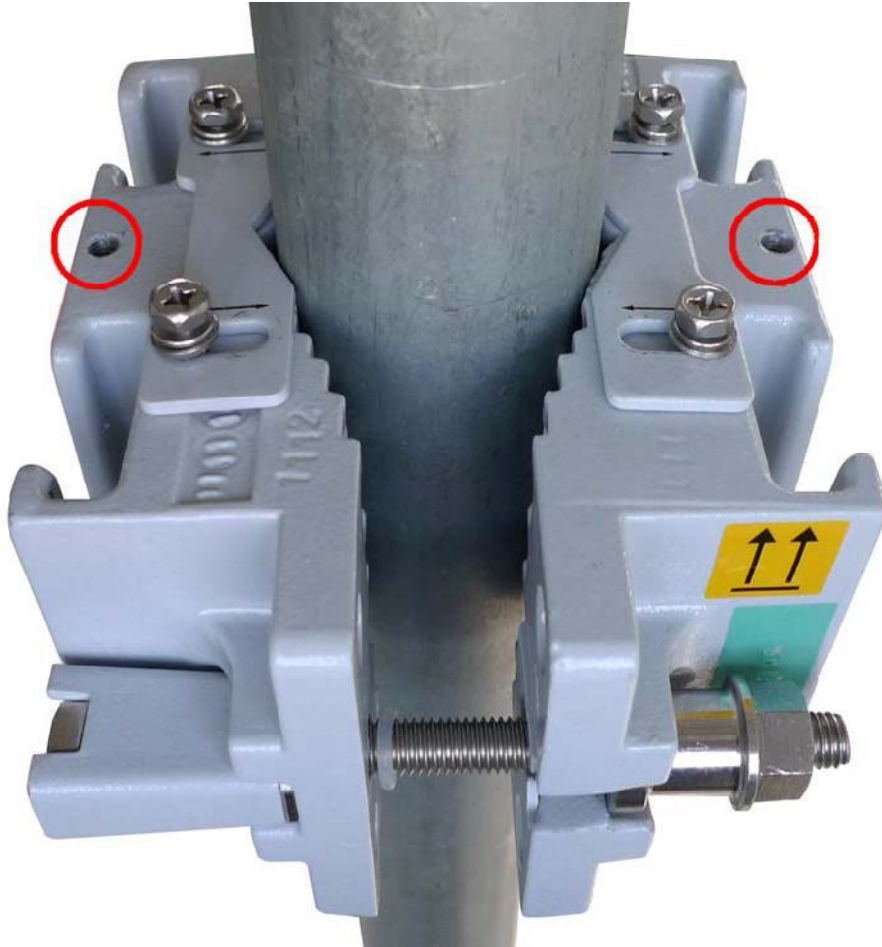

4. Remove the screw in the middle of each mounting bracket.



5. Fit the hangers of the RRU support into the grooves of the mounting bracket.



6. Reinstall the screw that is removed in Step 4 and tighten it to fasten the RRU.



7. This installation method is applicable to the installation of one or two ZXSDR R8881 S4200s.

3.3 Installing the ODCPD1

When a 16mm² power cable is used, the ODCPD1 is required.



1. Use four screws to fasten a mounting frame in the front of the device.



2. Use two screws to fasten the ODCPD1 on the mounting frame.



3. If two devices are installed in parallel, the ODCPD1s should be installed in this way: one is in the front and the other is at the back of devices respectively.

4 Cable Connection

4.1 ZXSDR R8881 S4200 Ports

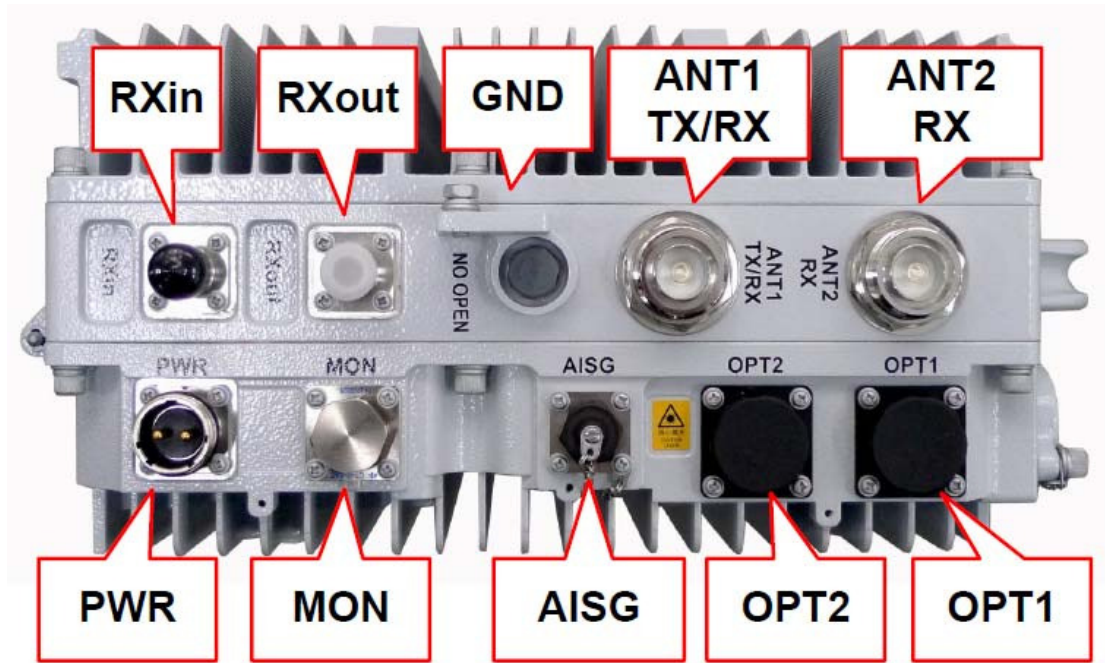

Label	Interface	Connector Type	Purpose
PWR	-48V DC Power Input Port	2-pin round connector (male)	Provides -48 V DC power supply
MON	Monitoring Port	8-pin round connector (male)	Used to monitor the dry contact devices
AISG	AISG Device Port	8-pin square connector (female)	Provides AISG connection for an electric tilt antenna
GND	Grounding Port	M6 grounding screw	Provides grounding connection
OPT1	Optical signal / electric signal interface. It includes a pair of transmitting and receiving channels	LC optical port (IEC 874)	Provides physical connection for the signals between the RRU and the BBU
OPT2			
Rxin	Signal input port for diversity reception	N type connector	Transmits RF signals
Rxout	Signal output port for main reception		
ANT2 RX	Diversity RF signal port	DIN type connector	Transmits RF signals
ANT1 TX/ RX	Main RF signal port		

4.2 Connecting Cables of ZXSDR R8881 S4200 (DC Power Supply)

4.2.1 Overview

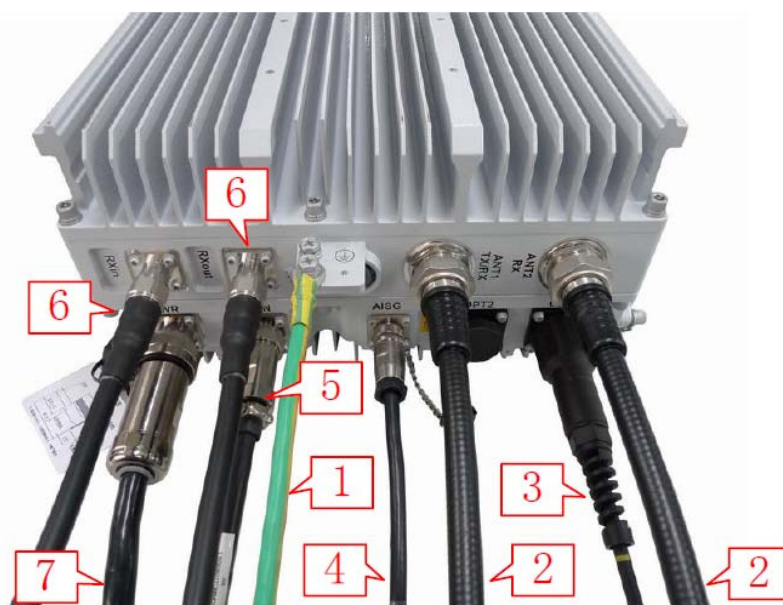

SN	Cable Name	Connection	
		End A	End B
1	Grounding wire	Outdoor grounding busbar	ZXSDR R8881 S4200 GND port
2	Main feeder	Feeder port of the antenna	ZXSDR R8881 S4200 ANT port
3	Optical fiber connecting to BBU	TX RX port on the BPL board of the BBU	ZXSDR R8881 S4200 OPT1 port
4	AISG cable	AISG port of the electric tilt antenna	ZXSDR R8881 S4200 AISG port
5	MON cable	The monitored device	ZXSDR R8881 S4200 MON port
6	Frequency spreading cable	RXout port of local R8881	Rxin port of remote ZXSDR R8881 S4200
7	power input cable	DC output port of the power supply device	ZXSDR R8881 S4200 PWR port

IMPORTANCE:

The power port of a DC-type ZXSDR R8881 S4200 is a two-core round connector (with pins). The DC power cable that is made at the site for the DC-type ZXSDR R8881 S4200

must be connected to the correct port on a DC power supply device otherwise, the ZXSDR R8881 S4200 may be damaged.



4.2.2 Connecting the Grounding Wire

1. Connect one end of the grounding wire to the GND port at the bottom of the ZXSDR R8881 S4200.
2. Connect the other end of the grounding wire to the nearest outdoor grounding busbar.
Note: When you connect cables, you should connect the grounding wire first and the power cable last. And when you disconnect cables, you should disconnect the power cable first and the grounding wire last.



3. If the ODCPD1 is used, use one grounding wire to connect the GND port of ZXSDR R8881 S4200 to the grounding point of the ODCPD1, and then use another grounding wire to connect the grounding point of the ODCPD1/PIMAC to the nearest outdoor grounding busbar.



4.2.3 Connecting the RF jumpers

Connect two feeders to the ANT1 and ANT2 ports of the ZXSDR R8881 S4200 respectively.

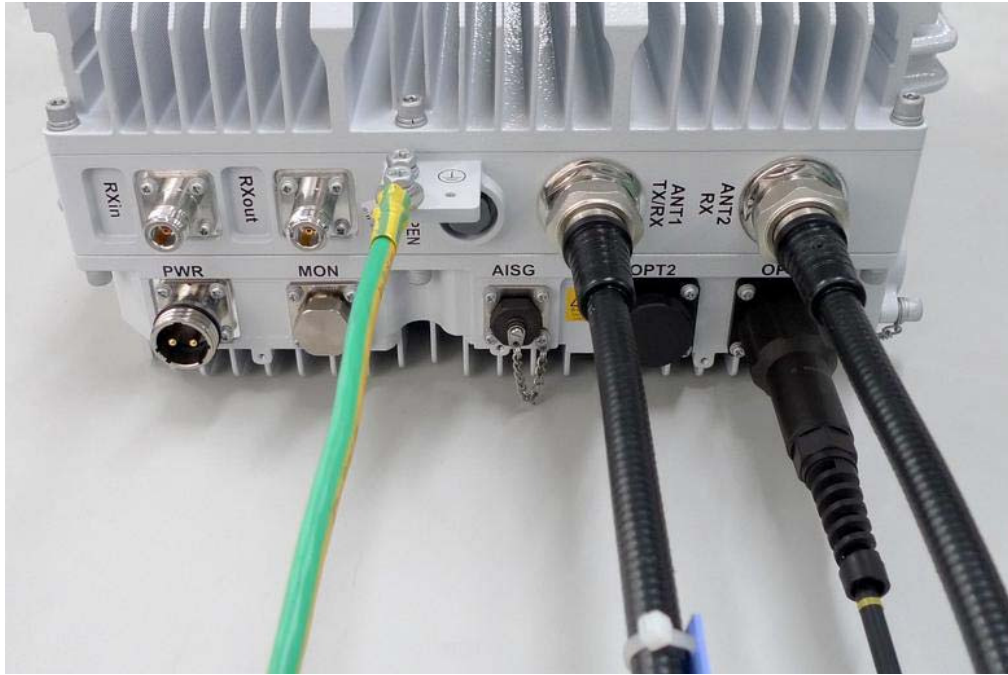

4.2.4 Connecting the Optical Fiber



1. Remove the protection cap from the optical fiber. Then, detach the outer protection cover.



2. Remove two white covers.



3. Insert the optical fiber into the OPT1 port until it locks into place with a click sound.



4. Insert the transparent sleeve into the OPT1 port fully.

5. Fasten the outer protection cover of the fiber until the yellow mark is exposed.



6. The optical fiber is thus connected to the OPT1 port of ZXSDR R8881 S4200.

7. In case of cascading, connect the optical fiber to the OPT2 port of the upper-level ZXSDR R8881 S4200 and the OPT1 port of the lower-level ZXSDR R8881 S4200.

4.2.5 Connecting the AISG Cable

Connect the AISG cable to the AISG port of the ZXSDR R8881 S4200.



4.2.6 Connecting the MON Cable

Connect the MON cable to the MON port of the ZXSDR R8881 S4200.



4.2.7 Connecting the Frequency Spreading Cable

In the case of frequency spreading, use a frequency spreading cable to connect the RXout port of the local R8881 to the RXin port of the remote ZXSDR R8881 S4200.

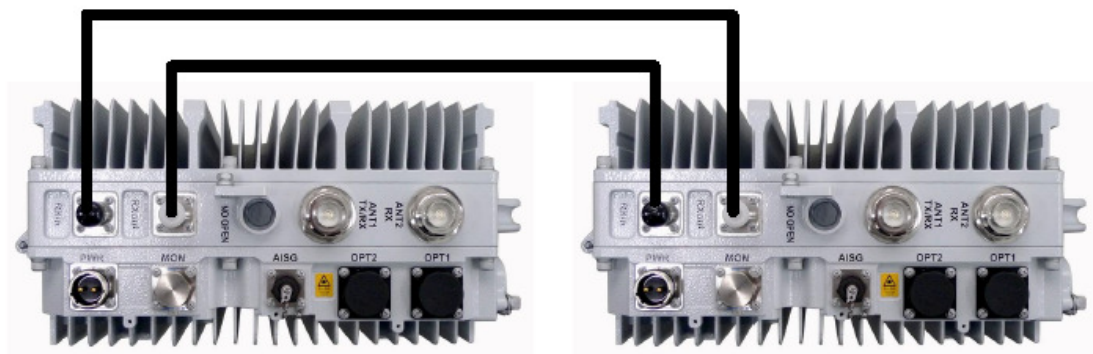

4.2.8 Making and Installing a Power Cable

1. Remove the bottom cover and the shell from a power connector.



2. Let a power cable pass through the bottom cover and the shell.



Note: If the 2x10 mm² cable is used, the rubber ring inside the connector shell should be removed. If the 2x4 mm² or 2x6 mm² cable is used, the rubber ring should be kept.

3. Loosen the four screws that hold the positive and negative wires and one screw that holds the shielding wire on the connector head.





4. Follow the instructions on the connector drawing to process the cable.

5. Insert the positive and negative wires to the correct holes of the power connector (The blue wire is negative and the black wire is positive).

6. Insert the shielding wire of the cable to the shielding wire hole.

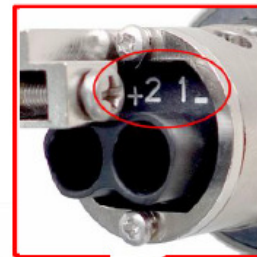
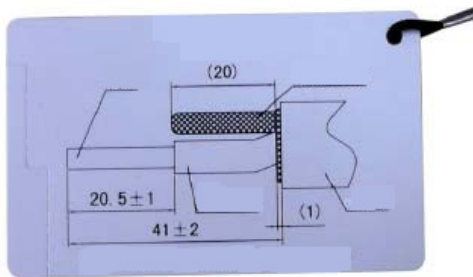

7. Tighten the four screws for positive and negative wires of the power cable. You should tighten the two screws that are close to the connector head first, and then the other two screws.

8. Tighten the screw for the shielding wire.

Note: After the five screws are all tightened, the cable should not be loosened under a pulling force of 2 Kg.



9. Use a wrench to hold the connector protection cover, and another to tighten the shell. The torque to tighten the shell should not be less than $1.2 \text{ N} \cdot \text{m}$.

10. Use a wrench to hold the connector shell, and another to tighten the bottom cover. The torque to tighten the cover should not be less than $1.2 \text{ N} \cdot \text{m}$.



11. After the power connector is made, you must test it with a multimeter. The connector should meet the following requirements:

- The holes are not short-circuited.
- The connector shell and the hole are not short-circuited.
- The shielding layer of the cable is conductive to the metal shell of the connector.
- The wire of the cable is conductive to the corresponding hole of the connector.

12. Take off the protection cover of the cable connector. Align the lock pins to the opening of the PWR port of the ZXSDR R8881 S4200, and insert the connector in position. Tighten the nut of the connector.



4.2.9 Connecting Cables of ODCPD1

1. Use a grounding wire to connect the grounding terminal of the ODCPD1 and the nearest outdoor grounding busbar.
Note: You can use any one of the two grounding terminals of ODCPD1.

2. Screw off the six screws on the cover of ODCPD1 to remove the cover.



3. Process the 16mm² power cable and ZXSDR R8881 S4200 power cable according to the drawings inside the ODCPD1 cover.

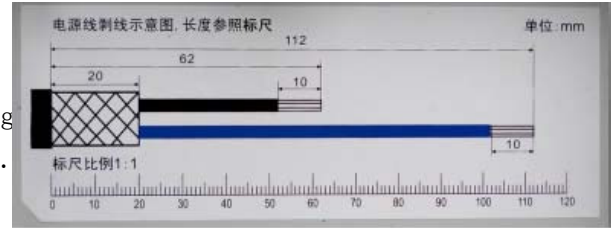

4. Crimp four lugs onto the ends of power wires.
5. Fix the power cables with the clamps on the ODCPD1. The 16mm² power cable should be on the right, and the ZXSDR R8881 S4200 power cable on the left.
6. Use screws to fasten the black wires on the -48VGND terminal.
7. Use screws to fasten the blue wires on the -48V terminal.
8. Fasten the cover of ODCPD1 with 6 screws.

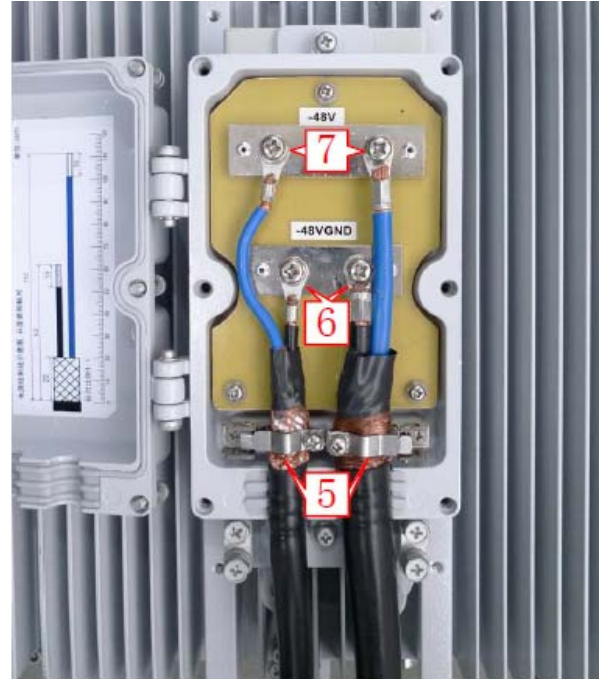

4.3 Selecting Positions for Grounding Clips

4.3.1 Grounding Clips for Antenna Feeders

1. When the RRU is installed close to the antenna,
 - 1.1 Grounding is not required if the feeder or jumper is less than 5 m.
 - 1.2 You should ground the feeder on the RRU side if the feeder is greater than 5 m but less than 20 m.
2. When the RRU is installed outdoors and far away from the antenna (greater than 20 m, and main feeder is used),
 - 2.1 You should ground the feeder on the RRU side.
 - 2.2 You should ground the feeder on the antenna side.
 - 2.3 If the feeder is laid on an iron tower, you should ground the feeder before it leaves the tower. If the distance from the tower to the RRU is less than 10 m, grounding is not required for the feeder before it leaves the tower. If the length of the feeder on the tower is greater than 60 m, you should ground the feeder at the middle position of the tower.
3. When the RRU is installed indoors,

3.1 You should ground the feeder at the very position before it goes through the feeder window of the equipment room.

3.2 You should ground the feeder on the antenna side.

3.3 If the feeder is laid on an iron tower, you should ground the feeder before it leaves the tower. If the distance from the tower to the feeder window is less than 10 m, grounding is not required for the feeder before it leaves the tower. If the length of the feeder on the tower is greater than 60 m, you should ground the feeder at the middle position of the tower.

4.3.2 Grounding Clips for Power Cables

1. Outdoor shielded DC power cables must be grounded near the feeder window of the equipment room, and the grounding clips must be connected to an outdoor grounding busbar. If the cable is grounded after it enters the equipment room through the feeder window, the cable where a grounding clip is applied must be wrapped with two layers of insulating tape. If the cable is grounded before it goes through the feeder window, the position of a cable where a grounding clip is applied must be processed with the “1-3-3” water-proof measure, that is, one-layer insulating adhesive tape, three-layer waterproof adhesive tape, and three-layer ultraviolet-proof adhesive tape.

2. Outdoor shielded DC power cables must be grounded before they enter an outdoor cabinet, and the grounding clips must be connected to an outdoor grounding busbar. The position of a cable where a grounding clip is applied must be processed with the “1-3-3” water-proof measure, that is, one-layer insulating adhesive tape, three-layer waterproof adhesive tape, and three-layer ultraviolet-proof adhesive tape.

5 Installation Check

SN	Checking Items	Result
1	The protection grounding wires of the equipment are properly installed to the nearest copper grounding busbar.	<input checked="" type="checkbox"/> Pass <input type="checkbox"/> Fail
2	Before connecting protection grounding wires, rust or dust should be removed from the surface of the grounding terminal to ensure reliable connections.	<input checked="" type="checkbox"/> Pass <input type="checkbox"/> Fail
3	The naked wires and the copper lugs of power cables or grounding wires should be covered with a tube or wrapped with insulating tape. The size of the copper lug should match the cable.	<input checked="" type="checkbox"/> Pass <input type="checkbox"/> Fail
4	The power cable should be connected correctly in terms of polarity. The power cables and grounding wires should be correctly and firmly connected. When the copper lug of a cable is connected to a terminal, flat washer and spring washer should be used and the spring washer should be pressed flat.	<input checked="" type="checkbox"/> Pass <input type="checkbox"/> Fail
5	The extra part of the grounding wires or power cables should be smoothly cut off rather than coiled. A whole cable segment with good insulating layer should be used. Do not join two or more cables.	<input checked="" type="checkbox"/> Pass <input type="checkbox"/> Fail
6	All cables (power cables, signal cables and pigtails) should be bound and laid by classification, with a minimum parallel distance of 5 cm.	<input checked="" type="checkbox"/> Pass <input type="checkbox"/> Fail
7	The bending radius of a cable should meet the requirements.	<input checked="" type="checkbox"/> Pass <input type="checkbox"/> Fail
8	The connectors of all cables should be properly and firmly connected. No DIN or N type of connector is connected in a staggered way.	<input checked="" type="checkbox"/> Pass <input type="checkbox"/> Fail
9	The black and white ties should not mix up. The white ties are used indoors, and its end should be smoothly cut off; while the black ties are used outdoors and 3 mm to 5 mm should be reserved at the end.	<input checked="" type="checkbox"/> Pass <input type="checkbox"/> Fail
10	All cable labels should face the same direction. The formats of cable labels should meet the corresponding requirements. If the customer provides special requirements, the formats should be consistent with those specified in the documentation provided by the customer.	<input checked="" type="checkbox"/> Pass <input type="checkbox"/> Fail

Antenna kit/Cable Specifications

Item	Description	Specification
1/2、 7/8 feeder	Frequency band range -MHz	410-425 MHz
	Joint Model	SL16 or uesr Specified
	Antenna Type/ Pattern:	Omnidirectional antenna
	Antenna's Gain	7.8 dBi
Cable Specifications	Feeder	1/2、 7/8 feeder

Environmental Specifications

IP level

The protection level is IP65.

Grounding Requirements

CBN ground resistance: $\leq 1 \Omega$; BTS ground resistance: $\leq 5 \Omega$.

Noise Specifications

Noise level in the operating environment: ≤ 65 dBA.

Reliability Specifications

The Mean Time Between Failures (MTBF): $> 450,000$ hours.

Availability: $> 99.9997\%$.

Radiation Exposure Statement(CE):

To comply with RF exposure requirements, the minimum safe distance is 3.454m required between the radiator and your body

FCC Radiation Exposure Statement:

Any Changes or modifications not expressly approved by the party responsible for compliance could void the user's authority to operate the equipment.

This device complies with part 15 of the FCC Rules. Operation is subject to the following two conditions: (1) This device may not cause harmful interference, and (2) this device must accept any interference received, including interference that may cause undesired operation.

Note: This equipment has been tested and found to comply with the limits for a Class A digital device, pursuant to part 15 of the FCC Rules. These limits are designed to provide reasonable protection against harmful interference when the equipment is operated in a commercial environment. This equipment generates uses and can radiate radio frequency energy and, if not installed and used in accordance with the instruction manual, may cause harmful interference to radio communications. Operation of this equipment in a residential area is likely to cause harmful interference in which case the user will be required to correct the interference at his own expense.

Warning

This equipment complies with FCC radiation exposure limits set forth for an uncontrolled environment.

This equipment should be installed and operated with minimum distance 3 m between the radiator & your body.