

# CAPTR II User Guide

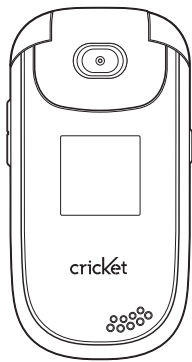

cricket

# Table of contents

<b>Safety</b> .....	<b>4</b>
About your device .....	4
<b>Before using your phone</b> .....	<b>6</b>
Handset description .....	6
Battery usage .....	7
Battery charging .....	7
Battery handling information .....	8
<b>Basic operation</b> .....	<b>9</b>
Turning the phone on/off .....	9
Accessing the menu .....	9
Using MyHomeScreen .....	10
Accessing the menu map .....	10
Basic functions .....	11
Making a call through the contact list .....	13
During a call .....	14
<b>Memory function</b> .....	<b>15</b>
Storing a phone number .....	15
Entering letters, numbers & symbols .....	15
<b>Recent calls</b> .....	<b>16</b>
All calls .....	16
Missed calls .....	16
Incoming calls .....	17

Outgoing calls .....	17
Call timers .....	17
<b>Messages</b> .....	<b>18</b>
Send text message .....	18
Send picture message .....	18
Inbox .....	19
Outbox .....	19
Drafts .....	20
Voicemail .....	20
Template .....	20
Settings .....	21
Erase messages .....	22
<b>Contacts</b> .....	<b>22</b>
MyBackup .....	22
Find .....	22
Add new entry .....	23
Speed dials .....	23
Group .....	24
Service number .....	24
My phone number .....	25
<b>Multimedia</b> .....	<b>25</b>
Camera .....	25
My images .....	26
My sounds .....	26
Camera settings .....	27
<b>Browser</b> .....	<b>27</b>
Browser menu .....	27

<b>Games &amp; Apps</b> .....	<b>27</b>
<b>Tools</b> .....	<b>28</b>
Bluetooth .....	28
Schedule .....	30
Alarm .....	31
World time .....	32
Memo pad .....	32
Calculator .....	33
Tip calculator .....	33
Stop watch .....	33
Unit converter .....	34
<b>Voice service</b> .....	<b>34</b>
Voice command .....	34
V.Cmd settings .....	35
Voice memo .....	35
<b>Settings</b> .....	<b>36</b>
Display .....	36
Sounds .....	38
Call .....	39
Security .....	40
System .....	43
Memory info .....	43
Phone info .....	44
<b>Care and maintenance</b> .....	<b>45</b>
<b>Warranty</b> .....	<b>46</b>
One (1) year limited warranty (U.S.) .....	46

<b>Additional safety information</b> .....	<b>52</b>
Small children .....	52
Operating environment .....	52
Medical devices .....	53
Vehicles .....	55
Potentially explosive environments .....	56
Emergency calls .....	56
Certification information (SAR) ..	57
Safety information for fixed wireless terminals potentially explosive atmospheres .....	58
Interference to medical devices .....	58
Exposure to RF energy .....	59
Body-worn operation .....	59
FCC compliance information .....	59
U.S.A. U.S.Federal communications commission radio frequency interference statement .....	59
FCC hearing-aid compatibility (HAC) regulations for wireless devices .....	60

# Safety

Read these simple guidelines. Not following them may be dangerous or illegal. Read the complete user guide for further information.

## Power on safely

Do not power on the device when and where prohibited or when it may cause interference or danger.

## Road safety comes first

Obey all local laws. Always keep your hands free to operate the vehicle while driving. Your first consideration while driving should be road safety.

## Interference

All wireless devices may be susceptible to interference, which could affect performance.

## Turn device off in restricted areas

Follow all warnings. Turn device off in aircraft, near medical equipment, fuel, chemicals, or blasting areas.

## Qualified service

Only qualified personnel may install or repair this product.

## Accessories and batteries

Use only approved accessories. Do not connect incompatible products.

## Water-resistance

Your device is not water-resistant. Keep it dry.

## About your device

The wireless device described in this guide is approved for use on the CDMA 800, 1700, 1900 and 2100 MHz networks. Contact your service provider for more information about networks.

When using the features in this device, obey all laws and respect local customs, privacy and legitimate rights of others, including copyrights.

Copyright protection may prevent some images, music, and other content from being copied, modified, or transferred.

Warning: To use any features in this device, other than the alarm clock, the device must be powered. Do not power the device on when wireless device use may cause interference or danger.

Remember to make back-up copies or keep a written record of all important information stored in your device.

When connecting to any other device, read its user guide for detailed safety instructions. Do not connect incompatible products.

# Before using your phone

## Handset description

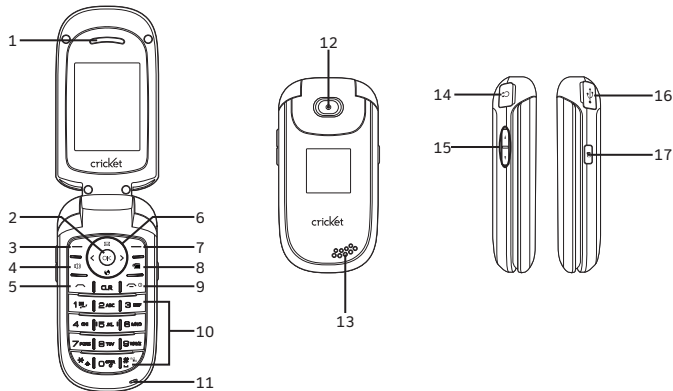

- 1. Earpiece
- 2. OK key
- 3. Menu key
- 4. Speakerphone key
- 5. Send key
- 6. Navigation key
- 7. Contacts menu
- 8. Schedule key
- 9. End key
- 10. Numeric keypad
- 11. Microphone
- 12. Camera lens

- 13. Speaker
- 14. Headset port
- 15. Side volume keys
- 16. Charger port
- 17. Camera key

## Battery usage

### Battery installation

1. Remove the battery cover from the unit.
2. Slide the battery into the slot located at the bottom of the unit and press until you hear the "Click".



### Battery removal

1. To remove the battery, push down on the top of the battery while inserting your finger into the slot and pulling up from the back of the battery and slide it out.
2. Align the cover tabs with the slots at the top of the device and slide the battery cover back onto the unit.



**note** If the battery is not correctly placed in the compartment, the handset will not turn on and/or the battery may detach during use.

## Battery charging

### Power connection

1. Plug the AC Charger into a standard outlet.
2. Plug the other end of the AC Charger into the charging port on your phone. The battery must be installed in the device to charge properly.

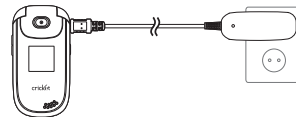

### **note**

- When you charge the battery with the phone powered off, you will see a charging status screen. You cannot operate the phone until it is powered on.

- The battery is not charged at the time of purchase.
- Fully charge the battery before use.
- It is more efficient to charge the battery with the handset is powered off.
- Battery operating time gradually decreases over time.
- If the battery fails to perform normally, you may need to replace the battery.

## Battery handling information

### Do's

- Only use the battery and charger approved by the manufacturer.
- Only use the battery for its original purpose.
- Try to keep batteries in a temperature between 41°F (5°C ) and 95°F (35°C).
- If the battery is stored in temperatures above or below the recommended range, give it time to warm up or cool down before using.
- Completely drain the battery before

recharging. It may take one to four days to completely drain.

- Store the discharged battery in a cool, dark, and dry place.
- Purchase a new battery when its operating time gradually decreases after fully charging.
- Properly dispose of the battery according to local laws.

### Don'ts

- Do not attempt to disassemble the battery – it is a sealed unit with no serviceable parts.
- Do not short circuit the battery by carrying it in your pocket or purse with other metallic objects such as coins, clips and pens. This may critically damage the battery.
- Do not leave the battery in hot or cold temperatures. Otherwise, it could significantly reduce the capacity and lifetime of the battery.
- Do not dispose of the battery into a fire.

# Basic operation

## Turning the phone on/off

### Turning the phone on

1. Press the END Key until the Cricket logo appears and the tone sounds.

#### **note**

- If “Password” appears on the display enter your 4-digit password to unlock your phone.
- The default password is the last 4 digits of your phone number.

### Turning the phone off

1. Press and hold the END Key until the Cricket logo appears.

#### **note**

- Immediately recharge or replace the battery when the warning “Please recharge battery soon” appears on the display.
- Turn the phone off before removing or replacing the battery. If the phone is on, unsaved data may be lost.

## Accessing the menu

Your phone can be customized via the menu. Each function can be accessed by scrolling with the Navigation Key or by pressing the number that corresponds with the menu item.

1. To access the menu in the idle mode, press the Left Soft Key **Menu**.
2. Press the Navigation Key up, down, left or right to choose the menu item, then press the OK Key. Press the Navigation Key up or down to scroll through the submenus for each menu item.
3. To return to the previous page, press the Clear Key. To exit the current menu and return to the idle mode, press the END Key.
4. Press the OK Key to enter ODP Menu. To scroll thru the widgets, press the right or left Navigation Key.

### **note**

- Navigation Key up : Messages
- Navigation Key down : Browser
- Navigation Key left : To scroll through the Widgets Menu.
- Navigation Key right : To scroll through the Widgets Menu.

## **Using MyHomeScreen (widgets)**

The MyHomeScreen menu (located at the bottom of the Idle screen) provides quick access to features like Weather, Weblinks, News, Mocospace, Horoscope, Personalize, My Account, Storefront and keeps them organized and always accessible.

1. To access the menu in the idle mode, press the Navigation Key right or left to scroll through the Menu or press the OK Key and then press the Navigation Key right or left to scroll thru the menu options.
2. To scroll through the Widget sub options, press the Navigation Key up or down. Press the OK Key to select an option.

3. To exit the Widget sub menu and return to the idle mode, press the END Key. To exit a Widget, press the CLR or END Key.

### **note**

- The default Widget Menu items - Personalize, My Account and Storefront - cannot be changed, deleted, or moved.

## **Accessing the menu map**

### **1. Recent Calls**

1. All Calls
2. Missed Calls
3. Incoming Calls
4. Outgoing Calls
5. Call Timers

### **2. Messages**

1. Send Text Msg.
2. Send Pic Msg.
3. Inbox
4. Outbox
5. Drafts
6. Voicemail
7. Template
8. Settings
9. Erase Messages

### **3. Contacts**

1. Find
2. Add New Entry
3. Speed Dials
4. Group
5. Service Number
6. My Phone Number

### **4. Multimedia**

1. Camera
2. My Images
3. My Sounds
4. Camera Settings

### **5. Browser**

### **6. Games & Apps**

### **7. Tools**

1. Bluetooth
2. Schedule
3. Alarm
4. World Time
5. Memo Pad
6. Calculator
7. Tip Calculator
8. Stop Watch
9. Unit Converter

### **8. Voice Service**

1. Voice Command
2. V.Cmd Settings
3. Voice Memo

### **9. Settings**

1. Display
2. Sounds
3. Call
4. Security
5. System
6. Memory Info
7. Phone Info

## **Basic functions**

### **Making a call**

1. Enter a phone number.

**note** To modify the phone number you have entered :

- To erase one digit at a time press the Clear Key.
  - To erase the entire number, press and hold the Clear Key.
2. Press the SEND Key.

### **note**

- If “CALL FAILED” appears on the

display or the line is busy, press the SEND Key or the END Key.

- If you activate the “AUTO RETRY” function, the phone will automatically retry for the number until you select the End Key.
- If “Please enter lock code” appears on the display enter your 4-digit password to unlock your phone.
- Your default password is the last 4 digits of your phone number.

3. To end a call, press the END Key.

### **Call answer**

1. When your phone rings or vibrates, press the SEND Key or open the flip, to answer the incoming call. (Depending on your phone's settings, you may also answer incoming calls by pressing any key. See page 40 for details.)

**note** To reject incoming calls, press the Right Soft Key **Reject**.

2. To end a call, press the END Key or close the phone.

## Wait/pause feature

Pauses are used for automated systems (i.e., Voicemail, calling cards). Insert a pause after a phone number then enter another group of numbers. The second set of numbers is dialed automatically after the pause. This feature is useful for dialing systems that require a code.

1. To insert a wait/pause, enter a phone number then press the Right Soft Key **Options**. Select either a Type 'P' ("P" appears) or a Type 'T' ("T" appears).

### **note**

- Type "P": A hard pause stops the calling sequence until further input from you.
  - Type "T": A two second pause stops the calling sequence for two seconds and then automatically sends the remaining digits.
2. Press the SEND Key to dial or Left Soft Key **Save** to save the number.

## 3-way calling

With 3-Way Calling, you can talk to two people at the same time.

1. Enter a number you wish to call then press the SEND Key.
2. Once you have established the connection, enter the second number you wish to call then press the SEND Key.
3. When you're connected to the second party, press the SEND Key again to begin your 3-Way call.

**note** 3-way calling is a system dependent feature. Please contact your service provider for details.

## Caller ID function

Identifies caller by displaying their phone number. If the caller's name and number are already stored in your phone book, their name will appear. This is a system dependent feature. Please contact your service provider for details.

## Call waiting function

Notifies you of an incoming call when you are already on a call by sounding a beep tone and displaying the caller's phone number.

1. To answer another call while on the phone, press the SEND Key. This places the first call on hold. To switch back to the first caller, press the SEND Key again.

**note** Call Waiting is a system dependent feature. Please contact your service provider for details.

## Adjusting volume

1. During a call, press Side Volume Key up or down to adjust the earpiece volume.

## Making a call through the contact list

### One-touch/two-touch dialing

Ideal for frequently dialed numbers, this feature allows entries in your contact list to be dialed via the

keypad with only one or two key presses. In order for One-Touch/Two-Touch Dialing to properly work, it must be enabled.

### One-touch dialing

2-9: Press and hold the corresponding memory number for more than 1 second.

### Two-touch dialing

10-99: Press and the first digit and second digits of the memory number short and long respectively.

### **note**

- If no phone number is stored in the location entered, "Speed dial is empty" will appear on the screen.
- If One Touch Dial is set to Off: Enter the speed dial location number then press the SEND Key.
- Location 1 is reserved for voicemail. Location 2-99 are unassigned. To assign a speed dial location, please see page 23.

## During a call

1. Press the Left Soft Key **Mute**.

- **Mute (Unmute)** : If you press Mute during a call, the person you are speaking with cannot hear you or any sounds from your side of the conversation. However, you can still hear them.

### note

- To deactivate, press the Left Soft Key **Unmute**.
  - The phone will automatically unmute in Emergency Call or Callback Mode.
2. Press the Right Soft Key **Options**.
- **Voice Memo** : To record a voice memo during a call.
  - **Call History** : To select a phone number from your Recent Calls List during a call.
  - **Contacts** : To view a phone number from your Contact list during a call.
  - **Messaging** : To send a text message (SMS) during a call.

- **Bluetooth** : When user is calling with CAPTR II mobile phone, user can select Bluetooth in order to call with Bluetooth headset.

## Making an emergency call

The 911 feature puts the phone in the Emergency Call Mode when you dial the preprogrammed emergency number, 911. It also operates in Lock Mode and outside the service area.

### 911 in lock mode

The 911 call service is available even in Lock Mode.

1. Enter "911", then press the SEND Key.
2. The call connects.
3. When the call ends, the phone returns to Lock Mode.

### 911 using any available system

1. Enter "911", then press the SEND Key.
2. The call connects.

3. The phone maintains the Emergency Mode and the phone can receive an incoming call from any available system. However, it cannot make a call while still in Emergency Callback Mode.

# Memory function

## Storing a phone number

The phone book stores up to 500 entries.

1. Enter phone number then press the Left Soft Key **Save**.
2. Select "New Entry" or "Existing Entry".
3. If "Existing entry" is selected, your contact list is displayed. Choose the entry to add the number, then press the Left Soft Key **Done**. Select the type of Phone you are adding from the icon list, then press the Left Soft Key **Select**. Press the Left Soft Key **Save**. Press the Navigation Key up or down to

select primary phone number, then press the Left Soft Key **Select** to save contact.

If "New entry" is selected, the New entry icon list appears. Press the Navigation Key up or down to choose the type of Phone you are adding. Press the Left Soft Key **Select** to select. Enter a name. To change the input mode, press the Right Soft Key **Options**. Press the Navigation Key down to enter information in other fields for the contact. Fields include "Name", "Phone number", "Email address", "URL", "Group", "Ring Tone", "Msg Alert", "Photo", "Secret", "Memo".

4. To store the entry in your contact list, press the Left Soft Key **Save**. "Saved." will be displayed.

## Entering letters, numbers & symbols

The input mode will automatically be activated when it is necessary to enter letters and numbers.



There are 5 available modes: T9Word, Abc, ABC, 123 and Symbols. The input mode indicator appears on the lower portion of the display when letters and numbers are entered. To select the desired input mode, press the Right Soft Key **Options**, then choose from the list on screen.

- Standard input mode : Use the digit keys to enter letters, numbers and characters.
- T9 input mode : T9 mode incorporates a built-in-dictionary to determine a word based on the entered characters. A word can be entered more quickly by pressing each key once per character.
- Number mode : Allows you to enter numbers.
- Symbol mode : Allows you to enter symbols.

## Recent calls

### All calls

1. Press the Left Soft Key **Menu** > **Recent Calls** > **All Calls**.  
If the number is already stored in your contact list, only the name appears. If the number is not stored, the number appears.
2. To view details, press the OK Key.

**note** After the 240<sup>th</sup> missed, incoming or outgoing calls, the oldest call will automatically be erased from the history.

### Missed calls

1. Press the Left Soft Key **Menu** > **Recent Calls** > **Missed Calls**. If the number is already stored in your contact list, only the name appears. If the number is not stored, the phone number appears.
2. To view missed call details, press the OK Key.

**note** After 80 missed calls, the oldest call will be automatically erased from the history.

### Incoming calls

1. Press the Left Soft Key **Menu** > **Recent Calls** > **Incoming Calls**.  
If the number is already stored in your contact list, only the name appears. If the number is not stored, the number appears.
2. To view incoming call details, press the OK Key.

**note** After 80 incoming calls, the oldest call will automatically be erased from the history.

### Outgoing calls

1. Press the Left Soft Key **Menu** > **Recent Calls** > **Outgoing Calls**.  
If the number is already stored in your contact list, only the name appears. If the number is not stored, the number appears.

2. To view outgoing call details, press the OK Key.

**note** After 80 outgoing calls, the oldest call will automatically be erased from the history.

### Call timers

Checks the usage time and manages your calls within the limit you set. The 11 timers include (Last Call, Outgoing Calls, Incoming Calls, Home Calls, Roam Calls, All Calls, Lifetime Calls, Transmitted KB, Received KB, Total KB, Lifetime Data Counter, Last Reset):

1. Press the OK Key **Menu** > **Recent Calls** > **Call Timers**.
2. To reset all timers, press the Right Soft Key **Reset All**. "Reset All?" will be displayed. Select "Yes" and press the OK Key.

# Messages

## Send text message

To send a new text message:

1. Press the Left Soft Key **Menu** > **Messages** > **Send Text Msg.**
2. Under “Send To”, input the phone number. Press the Left Soft Key **Next**.
  - Press the Right Soft Key **Options**. (Recent Calls, Contacts, Group Lists, Entry Mode)
3. Under “Enter Msg.”, input your message.
  - Press the Right Soft Key **Options**. (Preset Msgs., Entry Mode, Save as Draft, Save as Preset, Add to Contacts, Delivery, Cancel Msg.)
4. To send the message, press the Left Soft Key **Send**.

## Send picture message

To send a new picture message:

1. Press the Left Soft Key **Menu** > **Messages** > **Send Pic Msg.**
2. Under “Send To”, input the phone number. Press the Left Soft Key **Next**.
  - Press the Right Soft Key **Options**. (Add CC, Add BCC, Contacts, Recent Calls, Group Lists, Entry Mode)
3. Under “Subject”, enter your subject text. Press the Left Soft Key **OK**.
4. Under “Text”, input your message, then press the Left Soft Key **OK**.
5. Under “Image”, press the OK Key to select the picture you want to send. Press the Left Soft Key **Select**. You can only send one picture file per message.
6. Under “Sound”, then press the OK Key. Select the sound and press the Left Soft Key **Select**. You can only send one sound file per message.
7. Under “vCard”, you can only insert/remove one name card. Press the

OK Key, then Select the name card or the contact. Press the Left Soft Key **Done**.

8. Under “Priority”, select “Normal” or “Urgent” by pressing the Navigation Key Left or Right.
9. Under “Delivery ack”, select “Off” or “On” by pressing the Navigation Key Left or Right.
  - Press the Right Soft Key **Options**. (Add To, Add CC, Add BCC, Preview, Save As Draft, Save As Template, Cancel Msg.)
10. To send the picture message, press the Left Soft Key **Send**.

## Inbox

The Inbox manages received text/picture messages. To access:

1. Press the Left Soft Key **Menu** > **Messages** > **Inbox**.
2. To delete a message, press the Left Soft Key **Erase**, then select “Yes” and press the OK Key. To delete all messages, press the

Right Soft Key **Erase All**, then select “Yes” and press the OK Key.

3. Select a message, then press the OK Key. The message is displayed. Press the Left Soft Key **Reply**, to send the reply message.

## Outbox

Manages sent messages.

1. Press the Left Soft Key **Menu** > **Messages** > **Outbox**.
2. To delete all messages, press the Right Soft Key **Erase All**, then select “Yes” and press the OK Key.
3. Select a message, then press the OK Key. The message is displayed. Press the Left Soft Key **Reply**, to send the reply message.
  - Press the Right Soft Key **Options**. (Forward, Add to Contacts, Erase, Resend, Information)

## Drafts

Draft Folder contains any draft messages. If message composition is interrupted by a voice call or other interrupting event, the text of the current composition is automatically saved in the drafts folder.

1. Press the Left Soft Key **Menu** > **Messages** > **Drafts**.
2. Select a message then press the OK Key. Edit the message.
3. Under "Send To", input the phone number. Press the Left Soft Key **Next**.
4. To send the message, press the Left Soft Key **Send**.

## Voicemail

Voicemail allows callers to leave voice messages in your voice mailbox, and lets you review, play, and delete your voice messages any time you are in your Carrier's network coverage area.

## Call voicemail

1. Press the Left Soft Key **Menu** > **Messages** > **Voicemail** > **Call Voicemail**.

To quickly access voicemail, press and hold the 1 key. Follow voice prompts.

## Details

View last voicemail information.

1. Press the Left Soft Key **Menu** > **Messages** > **Voicemail** > **Details**.

## Clear notification

Delete the voicemail icon.

1. Press the Left Soft Key **Menu** > **Messages** > **Voicemail** > **Clear Notification**.

## Template

### Compose a template message

1. Press the Left Soft Key **Menu** > **Messages** > **Send Pic Msg..**
2. Compose an MMS message. (Insert a picture and so on.)

3. Press the Right Soft Key **Options**.
4. Select "7. Save as Template" and press the OK Key.

### Create an MMS from template

1. Press the Left Soft Key **Menu** > **Messages** > **Template**.
2. Select a template from list.
3. Input the phone number or Email.
4. Modify the contents (optional).
5. Send an MMS message.

## Settings

1. Press the Left Soft Key **Menu** > **Messages** > **Settings**.
  - Notification : To set a notification. Select "Msg. & Icon" or "Icon Only".
  - Auto Save : To automatically save a message after sending, select "Auto Save", "Prompt" or "Do Not Save".
  - Auto Erase : Automatically erases Inbox messages when new messages arrive. Select

"On" or "Off". Oldest message erased from Inbox automatically when Inbox is full.

- Auto View : To set Auto View. Select "On" or "Off".
- Entry Mode : To change the text input mode. Select "T9Word", "Abc", "ABC" or "123".
- Callback # : Allows you to input a specific callback number. Callback numbers are used in text messaging so the other party knows how to get back to you. Select "None", "MDN" or "Custom".
- Voicemail # : To set your voicemail number. Enter the desired voicemail access number. (Default setting is \*99)
- Signature : To create a signature that can be automatically inserted at the end of a text message. Select "None" or "Custom" then press the Left Soft Key **Set** to save the setting. If you select "Custom", the signature input screen appears.

- Preset Msgs. : The preset messages are displayed.
- Alert Time : To set Alert Time, Select “Once”, or “Every 1 Minute”.
- Prompt Download : To set Prompt Download. Select “Auto” or “Manual”.

### Erase messages

To erase all messages stored in your Inbox, Outbox, Drafts or Template folders.

1. Press the Left Soft Key **Menu** > **Messages** > **Erase Messages**.

- Inbox : To erase all Inbox messages.
- Outbox : To erase all Outbox messages.
- Drafts : To erase all Drafts messages.
- Template : To erase all Template messages.
- All Messages : To erase messages.

2. “Erase All?” will be displayed. Select “1. Yes” and press the OK

Key.

3. A confirmation message appears.

## Contacts

### MyBackup

MyBackup application will backup your contact list, perform regular updates and download contacts. Please contact your Service Provider for details including associated service costs.

### Find

Retrieves an entry by name and calls the primary number by simply pressing the SEND Key. You can review all the entries stored in your contacts list or quickly find an entry by entering a name or its character string.

1. Press the Left Soft Key **Menu** > **Contacts** > **Find**.
2. The list of names in your contacts is displayed alphabetically.

3. Enter a name or its character string or scroll through the list by pressing the Navigation Key up or down.

**note** MyBackup, which is the first item at **Find**, can backup and restore your Contacts to and from the server. Selecting MyBackup will launch this preloaded application at Games & Apps.

### Add new entry

To add a new entry:

1. Press the Left Soft Key **Menu** > **Contacts** > **Add New Entry**.
2. Fill in the fields as they are selected. Press the Navigation Key up or down to select a field.
  - Phone book fields : Name , Phone number (Mobile, Office, Home, Pager, Other), Email address, URL, Group (No Group, Family, Friends, Work), Ring Tone, Msg Alert, Photo, Secret, Memo

**note** See page 15 for more detailed

information about storing a number.

### Speed dials

In idle mode, calls can be placed to numbers stored in speed dial by pressing & holding the location number on the key pad. For a 2-digit location number, press the first number, then press and hold the second number.

**note** Speed Dial must be activated.

1. Press the Left Soft Key **Menu** > **Contacts** > **Speed Dials**.
2. To assign a phone number to a speed dial location, select the speed dial location, then press the Left Soft Key **Assign**.

**note**

- “empty” appears if the location is available.
  - Location 1 is reserved for voicemail.
3. Scroll to the contact in the list.
  4. If more than one number exists for the contact, press the Navigation Key left or right to select the phone

number for the speed dial location. The numbers will be displayed above the contact list.

5. Press the Left Soft Key **Done** to set the speed dial location.
  - Press the Right Soft Key **Options**. (Send Msg., Prepend, Erase)

**note** “Prepend” option is to allow you to add additional number prior to the phone number you want to call from Contacts when dialing. You can prepend the international dialing number, area code or calling card number before the phone number you try to call.

## Group

Allows you to classify phone entries into groups. Existing groups include No Group, Family, Friends, Work.

### Add new group

1. Press the Left Soft Key **Menu** > **Contacts** > **Group**.
2. Press the Left Soft Key **Add** to add a new group name.

24 Contacts

3. Input a new group name.
4. To save it, press the Left Soft Key **Save**.

- Press the Right Soft Key **Options**. (Ring Tone, Add Member, Rename, Remove Member, Remove All, Erase)

### Change group name

1. Press the Left Soft Key **Menu** > **Contacts** > **Group**.
2. Select an existing group name. Only groups you created can be renamed.
3. Press the Right Soft Key **Options**, then scroll to “Rename”, press the OK Key.
4. Input a new group name.
5. Press the Left Soft Key **Save** to save the setting.

### Service number

Your Contacts list is preprogrammed with contact numbers for various services.

1. Press the Left Soft Key **Menu** > **Contacts** > **Service Number**.
2. Select the number (Info “411” / Cust. Svc. “611” / Cust. Care “\*611” / \*PAY “\*729”) then press the OK Key.
3. Press the SEND Key to call.

### My phone number

Displays your phone number.

1. Press the Left Soft Key **Menu** > **Contacts** > **My Phone Number**.
2. Your phone number will be displayed.

## Multimedia

### Camera

#### Take picture

1. Press the Left Soft Key **Menu** > **Multimedia** > **Camera**, or press the Side Camera Key.
2. Point the camera lens at your subject. You can check the picture framing through the display screen.

3. Pressing the Right Soft Key **Options**, you can choose from the following:

- Resolution : 640 x 480, 320 x 240, 160 x 120, Wallpaper
- Self timer : Off, 2 Seconds, 5 Seconds, 10 Seconds
- Mirror : Vertical, Horizontal
- Quality : Fine, Normal, Economy
- Image effect : Normal, Antique, Bluish, Greenish, Reddish, Gray, Negative
- Fun frame : Off, Image 1, Image 2, Image 3, Image 4, Image 5, Image 6, Image 7, Image 8, Image 9
- Settings : Reset Settings, Help

**note** To view captured images, press the Left Soft Key **Gallery**.

4. Press the Side Camera Key or press the OK Key to take the picture.
5. Picture will be saved press the Left Soft Key **Save**.

## My images

In my Images you can view all the images you have taken.

1. Press the Left Soft Key **Menu** > **Multimedia** > **My Images**.
2. Press the Navigation Key up, down, left or right to select your desired images, then press the Right Soft Key **Options**.
3. Select one of the following options:
  - Take a Pic. : Take a new picture.
  - Get New : To get new wallpapers and/or screensavers.

**note** Additional charges apply for downloads.

- Assign : Assigns image as wallpaper to a contact, main display or front display. (Contacts, Main LCD, Front LCD)
- Edit Title : Rename the selected picture.
- Icon/List : Select Icon style or List style.
- Lock/Unlock : Select to lock or unlock the selected picture.

- Erase : To erase the pictures in your phone.
- Erase Multi Select : To erase multiple images.
- Erase All : To erase all the pictures in your phone.
- Image Info : Displays information about the selected image.

4. To send, press the Left Soft Key **Send**.

**note** See page 18 for more detailed information about send picture message.

## My sounds

This menu displays the list of downloaded ringtones.

1. Press the Left Soft Key **Menu** > **Multimedia** > **My Sounds**.
2. Scroll through the downloaded ringtones to display the ringtone you want.

## Camera settings

To configure camera settings.

1. Press the Left Soft Key **Menu** > **Multimedia** > **Camera Settings**.
  - Auto Save : To set Auto Save. Select “On” or “Off”, then press the Left Soft Key **Set** to save the setting.
  - Shutter Sounds : To set Shutter Sounds. Select “Off”, “Shutter 1”, “Shutter 2” or “Shutter 3”, then press the Left Soft Key **Set** to save the setting.

## Browser

To access the browser:

1. Press the Left Soft Key **Menu** > **Browser**.

### Browser menu

- Home : When the “Home” item is selected from the Browser Menu, the phone displays the homepage.
- Go To URL : Allows you to manually enter the URL address of a WAP

site. After entering an address, press the OK Key to go there directly.

- Search : Takes user to Search page.
- Mark Page : To save the page as a bookmark. Press the OK Key to save current website address.
- Forward : When the “Forward” item is selected from the Browser Menu, the phone displays the next page in the history. This is only available if the user has navigated backward in the history.
- Reload : Selecting the “Reload” item from the Browser Menu refreshes the current page.

## Games & Apps

To access Games & Apps (note: charges apply to download games and applications):

1. Press the Left Soft Key **Menu** > **Games & Apps**.
2. You will see myStuff. If you want to download games or etc., press the

Navigation Key Left.

3. Select from “Browse catalog” and press the OK Key. The server will launch. Browse through the catalog and press the OK Key to select an application and price plan. Then follow the prompts to download the application. Repeat this process for each additional application.
4. To exit “Games & Apps”, press the END Key.

## Tools

### Bluetooth

Using Bluetooth wireless, you can connect the phone wirelessly to other Bluetooth devices, talk hands-free or control the phone remotely. Bluetooth technology allows free wireless connections between compatible Bluetooth-compliant devices within a range of up to 30 feet. Since the devices communicate

using radio waves, they do not need to be in line of sight to each other.

### Bluetooth ON/OFF

To toggle Bluetooth® power On/Off.

1. Press the Left Soft Key **Menu** > **Tools** > **Bluetooth** > **Settings**.
2. Under “Set”, then select “Off” or “On” by pressing the Navigation Key Left or Right.
3. Press the Left Soft Key **Save**.

### New device

Pairing is the process that allows the handset to locate, establish and register a 1-to-1 connection with the target device.

1. Press the Left Soft Key **Menu** > **Tools** > **Bluetooth** > **My Devices**.
2. Press the Right Soft Key **Options**.
3. Select “1. Add New” and press the OK Key.
4. “Bluetooth is disabled. Enable?” will be displayed. Select “1. Yes” and press the OK Key.

5. The handset will automatically enable Bluetooth functionality and search for nearby Bluetooth devices.
6. Device found will appear in the “New Device” list. Press the Navigation Key up or down to select a device, press the Left Soft Key **Pair**.
7. The handset will prompt you for the password. Consult the Bluetooth® accessory (sold separately) instructions for the appropriate password (typically “0000”—4 zeroes). Enter the password, then press the OK Key.
8. Once connected, you can see the Bluetooth device name in the My Device list. If the phone is connected with Bluetooth device, then Bluetooth icon will be appear at the top of the LCD screen.

### note

- In the My Device list, to disconnect, press “Drop”. To reconnect, press the OK Key again.

- When an audio device is connected, you can select another device and the connection is automatically transferred from that audio device to the other one.
- If multiple devices are displayed, select the device you want to connect.

### Settings

To change Bluetooth settings:

1. Press the Left Soft Key **Menu** > **Tools** > **Bluetooth** > **Settings**.
  - Set : To toggle Bluetooth® power On/Off.
  - Visibility : Select Shown to All or Hidden.
  - Name : To edit the Bluetooth® name of your phone
2. Press the Left Soft Key **Save**.

### Support service

To view brief descriptions of the Services supported by the phone:

1. Press the Left Soft Key **Menu** > **Tools** > **Bluetooth** > **Support**

## Service.

2. Press the Navigation Key up or down to select one of the following Services, then press the OK Key. (Headset/Hands Free/Object Push/File Transfer)

## Information

Displays the bluetooth information (Name, Address):

1. Press the Left Soft Key **Menu** > **Tools** > **Bluetooth** > **Information**.
2. View information. To return to the previous page, press the Right Soft Key **Close**.

## Send an image or a sound via Bluetooth

1. Press the Left Soft Key **Menu** > **Multimedia** > Select a folder where the file exists, **My Images** or **My Sounds**.
2. Select a file you desire to send and press the Left Soft Key **Send**.
3. Select **Via Bluetooth**.

4. Select a target Bluetooth device to send.
5. Press the OK Key.

## Schedule

Sets an event and reminds you of that event.

### Add new event

1. Press the Left Soft Key **Menu** > **Tools** > **Schedule**.
2. Press the Navigation Key to choose a date in the calendar, then press the Left Soft Key **Add**.
3. The "Add New" screen will be displayed.
  - Title : Enter the event name.
  - Start date : You can edit the start date for the event.
  - Start time : Enter the start time. Press the Right Soft Key for **am** or **pm**.
  - End date : You can edit the end date for the event.
  - End time : Enter the end time. Press the Right Soft Key for **am**

or **pm**.

- Contents : Enter any notes for the event.
  - Notice : Enter when the alert should sound for the event (On time, Before 10min, Before 20min, Before 1 hour, Before one day).
  - Snooze field, set the snooze time (5 min, 10 min, 15 min, 20 min).
  - Ring Type : Press the OK Key to select a ringer for the event. Press the Left Soft Key **Set** when the ringer is selected.
4. Press the Left Soft Key **Save** to save the event or the Clear Key to return to the calendar.
  5. The date of the event will be marked on your calendar.

### View added events

1. Press the Left Soft Key **Menu** > **Tools** > **Schedule**.
2. Scroll to a date in the calendar and press the OK Key to view the event for that day.

3. Press the OK Key **View** to see the details for the event.
  - Press the Right Soft Key **Options**. (Add New, Go to Date, Erase, Erase All)Press the Left Soft Key **Edit** to edit the event, then press the Left Soft Key **Save** to save the event.

### note

- Schedule/Calendar - To quickly access your schedule/calendar, press the Calendar Key. To scroll thru the schedule/calendar, press the right, left, up or down Navigation Key to a specific date. Press the OK Key to select that date and entry events.

## Alarm

1. Press the Left Soft Key **Menu** > **Tools** > **Alarm**.
2. Select Alarm #1, 2 or 3 to set a new alarm. To edit an existing alarm, select the alarm name. Press the OK Key.



3. To save an alarm setting press the Left Soft Key **Save**.

- Set: Press the Navigation Key left or right to select alarm “On” or “Off”.
- Time: Use the keypad to set a time for the alarm and the Right Soft Key to select **am** or **pm**.
- Repeat: Press the Navigation Key left or right to select “Daily”, “Once”, “Mon to Fri” or “Sat to Sun”.
- Snooze: Press the Navigation Key left or right to select “5 min”, “10 min”, “15 min” or “20 min”.
- Ring Type: Press the OK Key to select a ringtone for the alarm sound.

### World time

1. Press the Left Soft Key **Menu** > **Tools** > **World Time**.
2. The world map appears with the city, date and time. Press the Navigation Key left or right to select another city.

- DST: Press the Left Soft Key **DST**, specifies whether the current time of the selected place is adjusted to Daylight Savings Time.
- Dual: Press the Right Soft Key **Dual** to set dual time. To display, Dual Clock feature must be turned on. See page 36.

### Memo pad

Your phone includes an internal memo pad that can be used to compose and store reminders and memos.

#### Add new memo

To compose a memo:

1. Press the Left Soft Key **Menu** > **Tools** > **Memo Pad**.
2. To add a new memo, press the Left Soft Key **Add**. Input a new text memo.
3. To save memo, press the Left Soft Key **Save**.

### View memo

To view a saved memo:

1. Press the Left Soft Key **Menu** > **Tools** > **Memo Pad**.
2. The Memo pad list of memos is displayed in the order they were saved. To add a new memo, press the Left Soft Key **Add**.
  - Highlight a memo and press the Right Soft Key **Options**. (Erase, Erase All)
3. To view a memo, highlight it and press the OK Key. Press the Right Soft Key **Erase** to erase the memo or press the Left Soft Key **Edit** to edit the text, then press the Left Soft Key **Save** to save the changes.

### Calculator

To access the calculator:

1. Press the Left Soft Key **Menu** > **Tools** > **Calculator**.
2. To reset, press the Clear Key or press the Right Soft Key **Clear**.

### Tip calculator

To access the Tip calculator:

1. Press the Left Soft Key **Menu** > **Tools** > **Tip Calculator**.
2. Enter the amount of your “Bill”.
  - Press the Left Soft Key **Point(.)** to enter a decimal point.
3. Enter the percentage “Rate”.
4. Enter the “# of people”. Press the OK Key to calculate the result.
  - Press the Right Soft Key **Erase**.

### Stop watch

To access the Stop watch:

1. Press the Left Soft Key **Menu** > **Tools** > **Stop Watch**.
2. Press the Left Soft Key **Start** to start the stopwatch.
3. Press the Left Soft Key **Lap** to save Lap time and start counting another. Up to 20 laps can be saved.
4. Press the Right Soft Key **Stop** to stop the stopwatch.

5. Press the Right Soft Key **Reset** to reset the stopwatch.

## Unit converter

To access the Unit converter:

1. Press the Left Soft Key **Menu** > **Tools** > **Unit Converter**.
2. Select the desired type of measurement, and then press the Down Key. (Length, Weight, Volume, Area, Temperature, Speed)

# Voice service

## Voice command

To use Voice Command:

1. Press the Left Soft Key **Menu** > **Voice Service** > **Voice Command**.
  - Call <Name or #> : Use the Call command to voice dial a name from your Contact list or a phone number. When dialing a number, pronounce each digit, but do not

pause noticeably between the digits.

- Lookup <Name> : Use the Lookup command to retrieve and display information for any name stored in your Contact list.
- Check <Item> : The Check command lets you check status information for your phone. You can say “Check” or “Check Status” to see and hear all status information.
- Press the Left Soft Key **Tutorial**. Voice Commands menu information appears. To return to the previous page, press the Left Soft Key **Skip**.
- Press the Right Soft Key **Settings**. (Confirmation, Adaptation, Audio Modes, About)

### note

- Voice Commands – To use the voice command, press and hold the Speaker Key for 3 seconds. To exit Voice Command, press END Key.
- Speaker Phone – To use the

speaker phone, press and release the Speaker Key. The Speaker phone icon is displayed in indicator area. To exit speaker mode, press and release the Speaker Key.

## V.Cmd settings

1. Press the Left Soft Key **Menu** > **Voice Service** > **V.Cmd settings**.
  - Confirmation : You can control when the system asks you to confirm a name or number. You can adapt the system to your voice for optimal recognition accuracy. During adaptation, the system will prompt you to speak a series of short phrases. If you need to erase adaptation data and set the system back to the factory default, select Reset Voice.
  - Adaptation : You can adapt the system to your voice for optimal recognition accuracy. During adaptation, the system will prompt you to speak a series

of short phrases. If you need to erase adaptation data and set the system back to the factory default, select Reset Voice.

- Audio Modes : You can control the level of audio guidance provided by the system. In prompt mode (the default), the system prompts for required information. In readout mode, the system prompts for required information and reads out the contents of the screen. In expert mode, audio guidance is provided by beeps only.
- About : It's shown a Vsuite information.

## Voice memo

Voice Memo allows you to record a reminder message that can be up to 4 minutes.

1. Press the Left Soft Key **Menu** > **Voice Service** > **Voice Memo**.
2. To record a voice memo, press the Left Soft Key **Record**.

3. To start recording, press the OK Key **Record**. To stop recording, press the OK Key **Stop** button and to save your voice memo, press the OK Key **Save** button one more time.
4. To play voice memo, select the voice tag you want to play then press the OK Key.
  - Press the Left Soft Key **Options**. (Rename, Erase, Erase all, Information)

## Settings

### Display

#### Menu style

To select how the Menu appears on your phone:

1. Press the Left Soft Key **Menu** > **Settings** > **Display** > **Menu Style**.
2. Select “2D Icon”, “3D Icon” or “List”.

3. Press the Left Soft Key **Set** to save the setting.

#### Wallpaper

1. Press the Left Soft Key **Menu** > **Settings** > **Display** > **Wallpaper**.
2. Select “Main Display” or “Front Display”.
3. Select “Preset Images” or “My Images”.
4. Press the Navigation Key up or down to scroll through the images.
5. Press the Right Soft Key **View** to view the image full screen. Press the Left Soft Key **Set** to save the image as your wallpaper.

#### Clock format

1. Press the Left Soft Key **Menu** > **Settings** > **Display** > **Clock Format**.
2. Select “Main Display” or “Front Display”.
  - Main Display : “Digital Clock”, “Dual Clock” or “Calendar”
  - Front Display : “Digital Clock”,

“Analog Clock” or “None”

3. Press the Left Soft Key **Set** to save the setting.

#### Incoming calls

1. Press the Left Soft Key **Menu** > **Settings** > **Display** > **Incoming Calls**.
2. Select “Main Display” or “Front Display”.
3. Select “Preset Images”, or “My Images”.
4. Press the Navigation Key up or down to scroll through the images.
5. Press the Right Soft Key **View** to view the image full screen. Press the Left Soft Key **Set** to save the image as your images.

#### Banner

1. Press the Left Soft Key **Menu** > **Settings** > **Display** > **Banner**.
2. Select “On” or “Off”.

**note** The edit banner, turn Banner on, then enter desired text.

3. Press the Left Soft Key **Set** to save the setting.

#### Backlight

1. Press the Left Soft Key **Menu** > **Settings** > **Display** > **Backlight**.
2. Select “Main Display”, “Keypad” or “Charger”.
  - Main Display : 7 Sec, 15 Sec, 30 Sec, Always On, Always Off
  - Keypad : 7 Sec, 15 Sec, 30 Sec, Always On, Always Off
  - Charger : 7 Sec, 15 Sec, 30 Sec, Always On, Always Off
3. Press the Left Soft Key **Set** to save the setting.

#### Contrast

1. Press the Left Soft Key **Menu** > **Settings** > **Display** > **Contrast**.
2. Move Navigation Key left or right to select the setting.
3. Press the Left Soft Key **Set** to save the setting.

## Brightness

1. Press the Left Soft Key **Menu** > **Settings** > **Display** > **Brightness**.
2. Move the Navigation Key left or right to select the setting.
3. Press the Left Soft Key **Set** to save the setting.

## Sounds

### Ring Tone

1. Press the Left Soft Key **Menu** > **Settings** > **Sounds** > **Ring Tone**.
2. Select "Voice Calls", "Messages" or "Voicemail".
  - Preset Sounds: Select ringtone.
  - My Sounds: Select download Ringer.
3. Press the Left Soft Key **Set** to save the setting.
4. Press the Right Soft Key **Play** to play the ringtone, then Press the Left Soft Key **Set** to save the ringtone.

## Volume

1. Press the Left Soft Key **Menu** > **Settings** > **Sounds** > **Volume**.
  - Voice Calls : To adjust voice calls volume.
  - Speakerphone : To adjust Speakerphone volume.
  - Earpiece : To adjust earpiece volume.
  - Headset : To adjust headset volume.
  - Messages : To adjust message volume.
  - Alarms & Schedule : To adjust alarms & schedule volume.
  - Key Tone : To adjust key tone volume.
2. Select a setting by pressing the Navigation Key left or right.
3. Press the Left Soft Key **Set** to save the setting.

## Alerts

1. Press the Left Soft Key **Menu** > **Settings** > **Sounds** > **Alerts**.

- Minute Beep : Sounds an alert every minute during a call.
  - Roaming : Sounds an alert when leaving a service area and entering a roaming service area.
  - Call Connect : Notifies you that a call has been successfully placed.
  - Power On/Off : To set phone to sound a tone when the phone is powered on/off.
2. Select "On" or "Off".
  3. Press the Left Soft Key **Set** to save the setting.

## Tone length

1. Press the Left Soft Key **Menu** > **Settings** > **Sounds** > **Tone Length**.
2. Select "Short" or "Long".
3. Press the Left Soft Key **Set** to save the setting.

## Call

### Contacts match

This function will match your abbreviated dialed number with an entry from your phone's contact list. After dialing 4 numbers, the phone will display contacts with the same sequence of numbers. Use the up/down Navigation Key to scroll to the desired contact.

1. Press the Left Soft Key **Menu** > **Settings** > **Call** > **Contacts Match**.
2. Select "On" or "Off".
3. Press the Left Soft Key **Set** to save the setting.

### Quick search

To set the quick search:

1. Press the Left Soft Key **Menu** > **Settings** > **Call** > **Quick Search**.
2. Select "On" or "Off".
3. Press the Left Soft Key **Set** to save the setting.

## Call answer

To select an answer mode:

1. Press the Left Soft Key **Menu** > **Settings** > **Call** > **Call Answer**.
2. Select “Send Key”, “Any Key” or “Folder Open”.
3. Press the Left Soft Key **Set** to save the setting.

## Auto retry

Automatically redials a call up to 5 times after a set time interval.

1. Press the Left Soft Key **Menu** > **Settings** > **Call** > **Auto Retry**.
2. Select “On” or “Off”.
3. Press the Left Soft Key **Set** to save the setting.

## TTY mode

Your phone is able to operate with a TTY (Teletypewriter) device in digital modes. This feature is system dependent and may not be available in all areas.

1. Press the Left Soft Key **Menu** > **Settings** > **Call** > **TTY Mode**.
2. Read the message, then press the Left Soft Key **Next**.
3. Select “TTY Full”, “TTY + Talk”, “TTY + Hear” or “TTY Off”.
4. Press the Left Soft Key **Set** to save the setting.

## Security

Prevents unauthorized use of your phone. The following settings can be restricted:

### Phone lock

Prevents the phone from being used without entering the password first.

1. Press the Left Soft Key **Menu** > **Settings** > **Security** > Enter your password. > **Phone Lock**.

**note** The default Lock code is the last 4 digits of your phone number.

2. Select “Lock Now”, “Unlock” or “On Power Up”.

3. Press the Left Soft Key **Set** to save the setting.

### Change lock code

Changes your 4-digit password.

1. Press the Left Soft Key **Menu** > **Settings** > **Security** > Enter your password. > **Change Lock Code**.

**note** The default Lock code is the last 4 digits of your phone number.

2. Enter your lock code.
3. “Create your new lock code” screen appears. Enter your new lock code.
4. “Re-enter your new lock code” screen appears. Enter your new lock code again.

### Special number

This feature allows you to set 3 phone numbers that can be called even when the phone is locked.

1. Press the Left Soft Key **Menu** > **Settings** > **Security** > Enter your password. > **Special Number**.

**note** The default Lock code is the last 4 digits of your phone number.

2. Select a location(1. 911, 2. \*911, 3. #911) and press the Left Soft Key **Edit**. Enter the phone number and press the Left Soft Key **Save** to save it to that location.
3. Press the Right Soft Key **Erase** to erase the Special Number. Select “1. Yes” and press the OK Key.

## Restriction

You can restrict incoming or outgoing calls, and international calls. When calls are restricted, calls still may be possible to the official emergency number programmed into your device.

1. Press the Left Soft Key **Menu** > **Settings** > **Security** > Enter your password. > **Restriction**.

**note** The default Lock code is the last 4 digits of your phone number.

2. Select “Allow All”, “Restrict All”, “Phonebook Allow”, “Phonebook

Restrict”, “Speed Dials 1~10 Allow” or “Speed Dials 1~50 Allow”, then press the Left Soft Key **Set** to save the setting.

## Erase

To erase all data in your phone:

1. Press the Left Soft Key **Menu** > **Settings** > **Security** > Enter your password. > **Erase**.

**note** The default Lock code is the last 4 digits of your phone number.

2. Select “Contacts”, “Messages”, “Voice Memos” or “Download Contents”, then press the OK Key.
3. “Erase All?” will be displayed. Select “1. Yes” and press the OK Key.
4. “Are you sure?” will be displayed. Select “1. Yes” and press the OK Key.

## Reset phone

All saved contents and preference setting will be reset to factory defaults.

42 Settings

1. Press the Left Soft Key **Menu** > **Settings** > **Security** > Enter your password. > **Reset Phone**.

**note** The default Lock code is the last 4 digits of your phone number.

2. “Reset phone?” will be displayed. Select “1. Yes” and press the OK Key.
3. “Are you sure?” will be displayed. Select “1. Yes” and press the OK Key.

## Erase all entries

All saved contents and preference settings will be reset to factory defaults.

1. Press the Left Soft Key **Menu** > **Settings** > **Security** > Enter your password. > **Erase All Entries**.

**note** The default Lock code is the last 4 digits of your phone number.

2. “Erase All Entries?” will be displayed. Select “1. Yes” and press the OK Key.
3. “Are you sure?” will be displayed.

Select “1. Yes” and press the OK Key.

## System

### Language

To change the language function:

1. Press the Left Soft Key **Menu** > **Settings** > **System** > **Language**.
2. Select “English” or “Spanish”.
3. Press the Left Soft Key **Set** to save the setting.

### Airplane mode

Airplane Mode deactivates the wireless connectivity of your phone but allows you to continue using non-network functions like the Calendar and games.

1. Press the Left Soft Key **Menu** > **Settings** > **System** > **Airplane Mode**.
2. Select “On”, “Off”.
3. Press the Left Soft Key **Set** to save the setting.

**note** You cannot make or receive calls or text messages when Airplane Mode is On.

## Location

To set the location function:

1. Press the Left Soft Key **Menu** > **Settings** > **System** > **Location**.
2. Select “Location On” or “E911 Only”.
3. Press the Left Soft Key **Set** to save the setting.

## System select

To set the location function:

1. Press the Left Soft Key **Menu** > **Settings** > **System** > **System Select**.
2. Select “Home Only” or “Automatic”.
3. Press the Left Soft Key **Set** to save the setting.

## Memory info

Displays the information of your Memory:

## User memory

1. Press the Left Soft Key **Menu** > **Settings** > **Memory Info** > **User Memory**.
2. My Images, My Sounds, MMS or Game&Apps is displayed.
3. To return to the previous page, press the Right Soft Key **Close**.

## Base memory

1. Press the Left Soft Key **Menu** > **Settings** > **Memory Info** > **Base Memory**.
2. Contacts, Messages, Tools or Recent Calls memory is displayed.
3. To return to the previous page, press the Right Soft Key **Close**.

## Phone info

Displays the information of your phone:

### My phone number

Displays your MDN and MIN.

1. Press the Left Soft Key **Menu** > **Settings** > **Phone Info** > **My Phone Number**.
2. The “MDN” and “MIN” will be displayed along with your service provider’s name.
3. To return to the previous page, press the Right Soft Key **Close** or OK Key.

## Version

Displays the S/W Version, H/W Version, PRL Version, Browser Name, Browser Version, Brew Version, PRI, ERI:

1. Press the Left Soft Key **Menu** > **Settings** > **Phone Info** > **Version**.
2. The S/W Version, H/W Version, PRL Version, Browser Name, Browser Version, Brew Version, PRI, ERI information is displayed.
3. To return to the previous page, press the Right Soft Key **Close** or OK Key.

## MEID/pESN

Displays your MEID(Dec), MEID(Hex), pESN(Dec), pESN(Hex).

1. Press the Left Soft Key **Menu** > **Settings** > **Phone Info** > **MEID/pESN**.
2. To return to the previous page, press the Right Soft Key **Close** or OK Key.

## Icon glossary

Displays the icons.

1. Press the Left Soft Key **Menu** > **Settings** > **Phone Info** > **Icon Glossary**.
2. Your phone’s indicator icons are displayed.
3. Press the OK Key, your phone’s indicator icons information are displayed.

# Care and maintenance

Your device is a product of superior design and craftsmanship and should be treated with care. The following suggestions will help you protect your warranty coverage.

- Keep the device dry. Precipitation, humidity, and all types of liquids or moisture can contain minerals that will corrode electronic circuits. If your device does get wet, remove the battery, and allow the device to dry completely before replacing it.
- Do not use or store the device in dusty, dirty areas. Its moving parts and electronic components can be damaged.
- Do not store the device in hot areas. High temperatures can shorten the life of electronic devices, damage batteries, and warp or melt certain plastics.
- Do not store the device in cold areas. When the device returns to

- its normal temperature, moisture can form inside the device and damage electronic circuit boards.
- Do not attempt to open the device other than as instructed in this guide.
- Do not drop, knock, or shake the device. Rough handling can break internal circuit boards and fine mechanics.
- Do not use harsh chemicals, cleaning solvents, or strong detergents to clean the device.
- Do not paint the device. Paint can clog the moving parts and prevent proper operation.
- Use only the supplied or an approved replacement antenna. Unauthorized antennas, modifications, or attachments could damage the device and may violate regulations governing radio devices.
- Use chargers indoors.
- Always create a backup of data you want to keep, such as contacts and calendar notes.

- To reset the device from time to time for optimum performance, power off the device and remove the battery.

These suggestions apply equally to your device, battery, charger, or any accessory. If the device is not working properly, take it to the nearest authorized service facility for service.

## Warranty

### **One (1) year limited warranty (U.S.)**

For products purchased from Cricket or its authorized dealers Cricket warrants that this device (“Product”) is free from defects in material and workmanship that result in Product failure during normal usage, according to the following terms and conditions (the “Limited Warranty”):

1. This Limited Warranty for the Product extends for one (1) year beginning on the date of the purchase of the Product.

2. The Limited Warranty extends only to the original purchaser (“Consumer”) of the Product and is not assignable or transferable to any subsequent purchaser/ end-user.
3. The Limited Warranty extends only to Consumers who purchase the Product from Cricket or its authorized dealers.
4. During the Limited Warranty period, Cricket will repair or replace, at Cricket’s sole option, any defective parts, or any parts that will not properly operate for their intended use with new or refurbished replacement items if such repair or replacement is needed because of product malfunction or failure during normal usage. the Limited Warranty does not cover defects in appearance, cosmetic, decorative or structural items, including framing, and any non-operative parts. Cricket’s limit of liability under the Limited Warranty shall

- be the actual cash value of the Product at the time the Consumer returns the Product for repair, determined by the price paid by the Consumer for the Product less a reasonable amount for usage. Cricket shall not be liable for any other losses or damages. these remedies are the Consumer’s exclusive remedies for breach of the Limited Warranty.
5. Upon request from Cricket, the Consumer must prove the date of the original purchase of the Product by a dated bill of sale or dated itemized receipt.
6. The Consumer shall bear the cost of shipping the Product to Cricket. Cricket shall bear the cost of shipping the Product back to the Consumer after the completion of service under this Limited Warranty.
7. The Consumer shall have no coverage or benefits under this Limited Warranty if any of the following conditions are applicable:



- a. the Product has been subjected to abnormal use, abnormal conditions, improper storage, exposure to moisture or dampness, unauthorized modifications, unauthorized connections, unauthorized repair, misuse, neglect, abuse, accident, alteration, improper installation, or other acts which are not the fault of Cricket, including damage caused by shipping.
  - b. the Product has been damaged from external causes such as collision with an object, or from fire, flooding, sand, dirt, windstorm, lightning, earthquake or damage from exposure to weather conditions, an act of God, or battery leakage, theft, blown fuse, or improper use of any electrical source, damage caused by computer or internet viruses, bugs, worms, trojan Horses, cancelbots or damage caused by the connection to other products (including but not limited to hardware and software) not recommended for interconnection by Cricket.
  - c. the Product serial number plate or the enhancement data code has been removed, defaced or altered.
  - d. the defect or damage was caused by the defective function of the cellular system or by inadequate signal reception by the external antenna, or viruses or other software problems introduced into the Product.
8. Cricket does not warrant uninterrupted or error-free operation of the Product. If a problem develops during the Limited Warranty period, the Consumer shall take the following step-by-step procedure:
- a. The Consumer shall return the Product to the place of purchase for repair or replacement processing.
  - b. The Consumer shall include a return address, daytime phone number and/ or fax number, complete description of the problem, proof of purchase and service agreement (if applicable). Expenses related to removing the Product from an installation are not covered under this Limited Warranty.
  - c. The Consumer will be billed for any parts or labor charges not covered by this Limited Warranty. the Consumer will be responsible for any expenses related to reinstallation of the Product.
  - d. Cricket will repair the Product under the Limited Warranty within 30 days after receipt of the Product. If Cricket cannot perform repairs covered under this Limited Warranty within 30 days, or after a reasonable number of attempts to repair the same defect, Cricket at its option, will provide a replacement Product or refund the purchase price of the Product less a reasonable amount for usage.
- e. If the Product is returned during the Limited Warranty period, but the problem with the Product is not covered under the terms and conditions of this Limited Warranty, the Consumer will be notified and given an estimate of the charges the Consumer must pay to have the Product repaired, with all shipping charges billed to the Consumer. If the estimate is refused, the Product will be returned freight collect. If the Product is returned after the expiration of the Limited Warranty period, Cricket's normal service policies shall apply and the Consumer will be responsible for all shipping charges.
9. You (the Consumer) understand that the Product may consist of refurbished equipment that contains used components, some of which have been reprocessed. the used components comply with Product performance and reliability

specifications.

10. Disclaimer of Warranty. EXCEPT AS SET FORTH IN THIS EXPRESS LIMITED WARRANTY, CONSUMER TAKES THE PRODUCT "AS IS", AND CRICKET MAKES NO WARRANTY OR REPRESENTATION AND THEREAFTER NO CONDITIONS, EXPRESS OR IMPLIED, STATUTORY OR OTHERWISE, OF ANY KIND WHATSOEVER WITH RESPECT TO THE PRODUCT, INCLUDING BUT NOT LIMITED TO ANY IMPLIED WARRANTY OF MERCHANTABILITY, OR FITNESS FOR A PARTICULAR PURPOSE OR USE; WARRANTIES OF TITLE OR NON-INFRINGEMENT; DESIGN, CONDITION, QUALITY, OR PERFORMANCE OF THE PRODUCT; THE WORKMANSHIP OF THE PRODUCT OR THE COMPONENTS CONTAINED THEREIN; OR COMPLIANT OF THE PRODUCT WITH THE REQUIREMENTS OF ANY LAW,

RULE, SPECIFICATION OR CONTRACT PERTAINING THERETO.

11. CRICKET SHALL NOT BE LIABLE FOR SPECIAL, INCIDENTAL, PUNITIVE OR CONSEQUENTIAL DAMAGES, INCLUDING BUT NOT LIMITED TO LOSS OF ANTICIPATED BENEFITS OR PROFITS, LOSS OF SAVINGS OR REVENUE, LOSS OF DATA, PUNITIVE DAMAGES, LOSS OF USE OF THE PRODUCT OR ANY ASSOCIATED EQUIPMENT, COST OF CAPITAL, COST OF ANY SUBSTITUTE EQUIPMENT OR FACILITIES, DOWNTIME, THE CLAIMS OF ANY THIRD PARTIES, INCLUDING CUSTOMERS, AND INJURY TO PROPERTY, RESULTING FROM THE PURCHASE OR USE OF THE PRODUCT OR ARISING FROM BREACH OF THE WARRANTY, BREACH OF CONTRACT, NEGLIGENCE, STRICT TORT, OR ANY OTHER LEGAL OR

EQUITABLE THEORY, EVEN IF CRICKET KNEW OF THE LIKELIHOOD OF SUCH DAMAGES. CRICKET SHALL NOT BE LIABLE FOR DELAY IN RENDERING SERVICE UNDER THE LIMITED WARRANTY, OR LOSS OF USE DURING THE PERIOD THAT THE PRODUCT IS BEING REPAIRED. NOTHING CONTAINED IN THE INSTRUCTION MANUAL SHALL BE CONSTRUED TO CREATE AN EXPRESS WARRANTY OF ANY KIND WHATSOEVER WITH RESPECT TO THE PRODUCT. ALL IMPLIED WARRANTIES AND CONDITIONS THAT MAY ARISE BY OPERATION OF LAW, INCLUDING IF APPLICABLE THE IMPLIED WARRANTIES OF MERCHANTABILITY AND FITNESS FOR A PARTICULAR PURPOSE, ARE HEREBY LIMITED TO THE SAME DURATION OF TIME AS THE EXPRESS WRITTEN WARRANTY STATED HEREIN.

12. Some states do not allow limitation of how long an implied warranty lasts, so the one (1) year warranty limitation may not apply to you (the Consumer). Some states do not allow the exclusion or limitation of incidental and consequential damages, so certain of the above limitations or exclusions may not apply to you (the Consumer). this Limited Warranty gives the Consumer specific legal rights and the Consumer may also have other rights which vary from state to state.

13. Cricket neither assumes nor authorizes any authorized service center or any other person or entity to assume for it any other obligation or liability beyond that which is expressly provided for in this Limited Warranty including the provider or seller of any extended warranty or service agreement.

14. This is the entire warranty between Cricket and the

Consumer, and supersedes all prior and contemporaneous agreements or understandings, oral or written, relating to the Product, and no representation, promise or condition not contained herein shall modify these terms. The agents, employees, distributors, and dealers of Cricket are not authorized to make modifications to this Limited Warranty, or make additional warranties binding on Cricket. Accordingly, additional statements such as dealer advertising or presentation, whether oral or written, do not constitute warranties by Cricket and should not be relied upon.

15. This Limited Warranty allocates the risk of failure of the Product between the Consumer and Cricket. The allocation is recognized by the Consumer and is reflected in the purchase price.
16. IF ANY PORTION OF THIS LIMITED WARRANTY IS HELD

ILLEGAL OR UNENFORCEABLE BY REASON OF ANY LAW, SUCH PARTIAL ILLEGALITY OR UNENFORCEABILITY SHALL NOT AFFECT THE ENFORCEABILITY FOR THE REMAINDER OF THIS LIMITED WARRANTY WHICH PURCHASER ACKNOWLEDGES IS AND WILL ALWAYS BE CONSTRUED TO BE LIMITED BY ITS TERMS OR AS LIMITED AS THE LAW PERMITS.

## Additional safety information

### Small children

Your device and its enhancements may contain small parts. Keep them out of the reach of small children.

### Operating environment

This device meets RF exposure guidelines when used either in the normal use position against the ear or when positioned at least 2.2

centimeters (7/8 inches) away from the body. When a carry case, belt clip, or holder is used for body-worn operation, it should not contain metal and should position the device the above-stated distance from your body.

To transmit data files or messages, this device requires a quality connection to the network. In some cases, transmission of data files or messages may be delayed until such a connection is available. Ensure the above separation distance instructions are followed until the transmission is completed.

Parts of the device are magnetic. Metallic materials may be attracted to the device. Do not place credit cards or other magnetic storage media near the device, because information stored on them may be erased.

### Medical devices

Operation of any radio transmitting equipment, including wireless devices, may interfere with the

functionality of inadequately protected medical devices. Consult a physician or the manufacturer of the medical device to determine if they are adequately shielded from external RF energy or if you have any questions. Switch off your device in health care facilities when any regulations posted in these areas instruct you to do so. Hospitals or health care facilities may be using equipment that could be sensitive to external RF energy.

### Implanted medical devices

Manufacturers of medical devices recommend that a minimum separation of 15.3 centimeters (6 inches) should be maintained between a wireless device and an implanted medical device, such as a pacemaker or implanted cardioverter defibrillator, to avoid potential interference with the medical device. Persons who have such devices should:

- Always keep the wireless device more than 15.3 centimeters (6 inches) from the medical device when the wireless device is turned on.
- Not carry the wireless device in a breast pocket.
- Hold the wireless device to the ear opposite the medical device to minimize the potential for interference.
- Turn the wireless device off immediately if there is any reason to suspect that interference is taking place.
- Read and follow the directions from the manufacturer of their implanted medical device.

If have any questions about using your wireless device with an implanted medical device, consult your health care provider.

### Hearing aids

Some digital wireless devices may interfere with some hearing aids. If interference occurs, consult your service provider.

### Hearing aid compatibility

Your mobile device model complies with FCC rules governing hearing aid compatibility. These rules require an M3 microphone or higher value. The M-value, shown on the device box, refers to lower radio frequency (RF) emissions. A higher M-value generally indicates that a device model has a lower RF emissions level, which may improve the likelihood that the device will operate with certain hearing aids. Some hearing aids are more immune than others to interference. Please consult your hearing health professional to determine the M-rating of your hearing aid and whether your hearing aid will work with this device.

This device includes a setting for direct connection to telecoil equipped hearing aids. When both the telecoil hearing aid (T switch) and the phone telecoil are activated, using the device with the aided ear will provide a direct connection for audio through your hearing aid. The quality of sound depends on the type of hearing aid used. You should test the device with the telecoil setting activated to determine whether your audio performance improves. Using the telecoil hearing-aid setting consumes additional battery power. More information on accessibility can be found at.

### Vehicles

RF signals may affect improperly installed or inadequately shielded electronic systems in motor vehicles such as electronic fuel injection systems, electronic antiskid (antilock) braking systems, electronic speed control systems, and air bag systems. For more information, check with the

manufacturer, or its representative, of your vehicle or any equipment that has been added.

Only qualified personnel should service the device or install the device in a vehicle. Faulty installation or service may be dangerous and may invalidate any warranty that may apply to the device. Check regularly that all wireless device equipment in your vehicle is mounted and operating properly. Do not store or carry flammable liquids, gases, or explosive materials in the same compartment as the device, its parts, or enhancements. For vehicles equipped with an air bag, remember that air bags inflate with great force. Do not place objects, including installed or portable wireless equipment in the area over the air bag or in the air bag deployment area.

If in-vehicle wireless equipment is improperly installed and the air bag inflates, serious injury could result.

Using your device while flying in aircraft is prohibited. Switch off your device before boarding an aircraft. The use of wireless teledevices in an aircraft may be dangerous to the operation of the aircraft, disrupt the wireless telephone network, and may be illegal.

### **Potentially explosive environments**

Switch off your device when in any area with a potentially explosive atmosphere, and obey all signs and instructions. Potentially explosive atmospheres include areas where you would normally be advised to turn off your vehicle engine. Sparks in such areas could cause an explosion or fire resulting in bodily injury or even death. Switch off the device at refueling points such as near gas pumps at service stations. Observe restrictions on the use of radio equipment in fuel depots, storage, and distribution areas; chemical plants; or where blasting operations are in progress. Areas

with a potentially explosive atmosphere are often, but not always, clearly marked. They include below deck on boats, chemical transfer or storage facilities and areas where the air contains chemicals or particles such as grain, dust, or metal powders. You should check with the manufacturers of vehicles using liquefied petroleum gas (such as propane or butane) to determine if this device can be safely used in their vicinity.

### **Emergency calls**

Important: This device operates using radio signals, wireless networks, landline networks, and user-programmed functions. Connections in all conditions cannot be guaranteed. You should never rely solely on any wireless device for essential communications like medical emergencies.

### **To make an emergency call:**

1. If the device is not on, switch it on. Check for adequate signal strength. Depending on your device, you may also need to complete the following:
  - Remove certain call restrictions you have activated in your device.
2. Press the END Key as many times as needed to clear the display and ready the device for calls.
3. Enter the official emergency number for your present location. Emergency numbers vary by location.
4. Press the SEND Key.

When making an emergency call, give all the necessary information as accurately as possible. Your wireless device may be the only means of communication at the scene of an accident. Do not end the call until given permission to do so.

### **Certification information (SAR)**

This mobile device meets guidelines for exposure to radio waves.

Your mobile device is a radio transmitter and receiver. It is designed not to exceed the limits for exposure to radio waves recommended by international guidelines. These guidelines were developed by the independent scientific organization ICNIRP and include safety margins designed to assure the protection of all persons, regardless of age and health.

The exposure guidelines for mobile devices employ a unit of measurement known as the Specific Absorption Rate or SAR. The SAR limit stated in the ICNIRP guidelines is 1.6 watts/kilogram (W/kg) averaged over 1 grams of tissue. Tests for SAR are conducted using standard operating positions with the device transmitting at its highest certified power level in all tested frequency bands. The actual SAR level of an

operating device can be below the maximum value because the device is designed to use only the power required to reach the network. That amount changes depending on a number of factors such as how close you are to a network base station.

Use of device accessories and enhancements may result in different SAR values. SAR values may vary depending on national reporting and testing requirements and the network band. Additional SAR information may be provided under product information at.

Your mobile device is also designed to meet the requirements for exposure to radio waves established by the Federal Communications Commission (USA) and Industry Canada. These requirements set a SAR limit of 1.6 W/kg averaged over one gram of tissue. The highest SAR value reported under this standard during product certification for use at the ear is 0.833W/Kg and when

properly worn on the body is 0.304W/Kg.

### **SAFETY INFORMATION FOR FIXED WIRELESS TERMINALS POTENTIALLY EXPLOSIVE ATMOSPHERES**

Turn your phone OFF when in any area with a potentially explosive atmosphere and obey all signs and instructions. Sparks in such areas could cause an explosion or fire resulting in bodily injury or even death.

### **INTERFERENCE TO MEDICAL DIVICES**

Certain electronic equipment may be shielded against RF signal from you wireless phone. (pacemakers, Hearing Aids, and so on) Turn your phone OFF in health care facilities when any regulations posted in these areas instruct you to do so. RF signals may affect improperly installed or inadequately shielded electronic system in motor vehicles.

### **EXPOSURE TO RF ENERGY**

Use only the supplied or an approved replacement antenna. Do not touch the antenna unnecessarily when the phone is in use. Do not move the antenna close to, or touching any exposed part of the body when making a call.

### **BODY-WORN OPERATION**

This device was tested for typical body-worn operations with the back of the phone kept 2.0 cm from the body. To maintain compliance with FCC RF exposure requirements, use only belt-clips, holsters or similar accessories that maintain 2.0 cm separation distance between the user's body and the back of the phone, including the antenna. The use of belt-clips, holsters and similar accessories should not contain metallic components in its assembly. The use of accessories that do not satisfy these requirements may not comply with FCC RF exposure requirements, and should be

avoided.

For more information about RF exposure, please visit the FCC website at [www.fcc.gov](http://www.fcc.gov).

### **FCC compliance information**

This device complies with Part 15 of FCC Rules. Operation is subject to the following two conditions:

- (1) This device may not cause harmful interference, and
- (2) This device must accept any interference received.

Including interference that may cause undesired operation.

### **U.S.A.**

### **U.S.FEDERAL COMMUNICATIONS COMMISSION RADIO FREQUENCY INTERFERENCE STATEMENT**

### **INFORMATION TO THE USER**

**note** This equipment has been tested and found to comply with the limits for a Class B digital device pursuant to Part 15 of the FCC Rules. These limits are designed to provide

reasonable protection against harmful Interference in a residential installation. This equipment generates, uses, and can radiate radio frequency energy and, if Not installed and used in accordance with the instructions, may cause harmful Interference to radio communications. However, there is no guarantee that interference will not occur in a particular Installation. If this equipment does cause harmful interference to radio or television reception, which can be determined by turning the equipment off and on, the user is encouraged to try to correct the interference by one or more of the following measures:

- \*- Reorient or relocate the receiving antenna. Increase the separation between the equipment and receiver.
- \*- Connect the equipment into an outlet of a circuit different from that to which the receiver is connected.
- \*- Consult the dealer or an

experienced radio/TV technician for assistance.

Changes or modification not expressly approved by the party responsible for Compliance could void the user's authority to operate the equipment. Connecting of peripherals requires the use of grounded shielded signal cables.

#### **FCC hearing-aid compatibility (HAC) regulations for wireless devices**

On July 10, 2003, the U.S. Federal Communications Commission (FCC) Report and Order in WT Docket 01-309 modified the exception of wireless phones under the Hearing Aid Compatibility Act of 1988 (HAC Act) to require digital wireless phones be compatible with hearing-aids. The intent of the HAC Act is to ensure reasonable access to telecommunications services for persons with hearing disabilities. While some wireless phones are used near some hearing devices

(hearing aids and cochlear implants), users may detect a buzzing, humming, or whining noise. Some hearing devices are more immune than others to this interference noise, and phones also vary in the amount of interference they generate. The wireless telephone industry has developed a rating system for wireless phones, to assist hearing device users find phones that may be compatible with their hearing devices. Not all phones have been rated. Phones that are rated have the rating on their box or a label located on the box. The ratings are not guarantees. Results will vary depending on the user's hearing device and hearing loss. If your hearing device happens to be vulnerable to interference, you may not be able to use a rated phone successfully. Trying out the phone with your hearing device is the best way to evaluate it for your personal needs.

**M-Ratings:** Phones rated M3 or M4 meet FCC requirements and are likely to generate less



interference to hearing devices than phones that are not labeled. M4 is the better/higher of the two ratings. Hearing devices may also be rated. Your hearing device manufacturer or hearing health professional may help you find this rating. Higher ratings mean that the hearing device is relatively immune to interference noise. The hearing aid and wireless phone rating values are then added together. A sum of 5 is considered acceptable for normal use. A sum of 6 is considered for best use. In the above example, if a hearing aid meets the M2 level rating and the wireless phone meets the M3 level rating, the sum of the two values equal M5. This should provide the hearing aid user with "normal usage" while using their hearing aid with the particular wireless phone.

“Normal usage” in this context is defined as a signal quality that is acceptable for normal operation. The M mark is intended to be synonymous with the U mark. The T mark is intended to be synonymous with the UT mark. The M and T marks are recommended by the Alliance for Telecommunications Industries Solutions (ATIS). The U and UT marks are referenced in Section 20.19 of the FCC Rules. The HAC rating and measurement procedure are described in the American National Standards Institute (ANSI) C63.19 standard.