

UserGuide

MF279

WCDMA/LTE CPE

Welcome to AT&T

Thank you for purchasing the WCDMA/LTE CPE (Model: MF279). To get the most from your new device, check out our videos and interactive tutorials at att.com/homebasesupport.

Contents

UserGuide	1
Getting Started.....	5
<i>In the Box</i>	5
<i>Getting to Know Your Device</i>	5
<i>Indicators</i>	6
<i>How It Works</i>	7
<i>Device Installation</i>	7
Before You Begin	7
<i>Voicemail</i>	13
Setup	13
Message Waiting	13
Retrieving Messages	13
Remote Retrieval.....	13
<i>Transferring a Phone Number</i>	14
<i>AT&T Home Base Manager</i>	14
Using Your Device	15
<i>Calling</i>	15
Making Calls.....	15
Three-Way Calling	15
Call Waiting	15
Call Forwarding	16
Call Log.....	16
<i>Internet Access</i>	16
Connect Other Devices	16
Changing Wi-Fi Network Name and Password	17
Important Messages	17
Managing Connected Devices	17
Parental Control.....	17
<i>Checking Your Voice and Data Usage</i>	18
<i>Helpful Tips</i>	19
Home Answering Machines.....	19
Adjusting Volume	19
Powering On/Off.....	19
TTY Support.....	20
Important Information	20
<i>E911 Service</i>	20
<i>Power Outages</i>	20
<i>Back-up Battery</i>	20
<i>Device Compatibility</i>	21
<i>In-Home Wiring</i>	21
Frequently Asked Questions	21
Troubleshooting.....	23

<i>General</i>	23
<i>Phone</i>	24
<i>Internet</i>	25
Device Configuration	27
<i>Wi-Fi Settings</i>	27
Basic	27
Connections	28
Security	28
WPS	29
<i>Network</i>	29
Connections	30
<i>Firewall</i>	30
MAC/IP/Port Filtering	30
Port Forwarding	31
DMZ	31
<i>Advanced</i>	32
Administrator	32
Router	32
Call Blocking	34
Backup/Restore	34
Specifications	34
Safety Instructions	34
FCC Regulations	35
RF Exposure Information	35
CTIA	36
Warranty	36
<i>How to Get Warranty Service</i>	37
<i>Other Warranty Programs</i>	37

Getting Started

In the Box

The package contains the following items:

- MF279
- Power Cord
- Phone Cable (Optional)
- Back-up Battery
- Get Started Guide
- User Guide (This Guide)



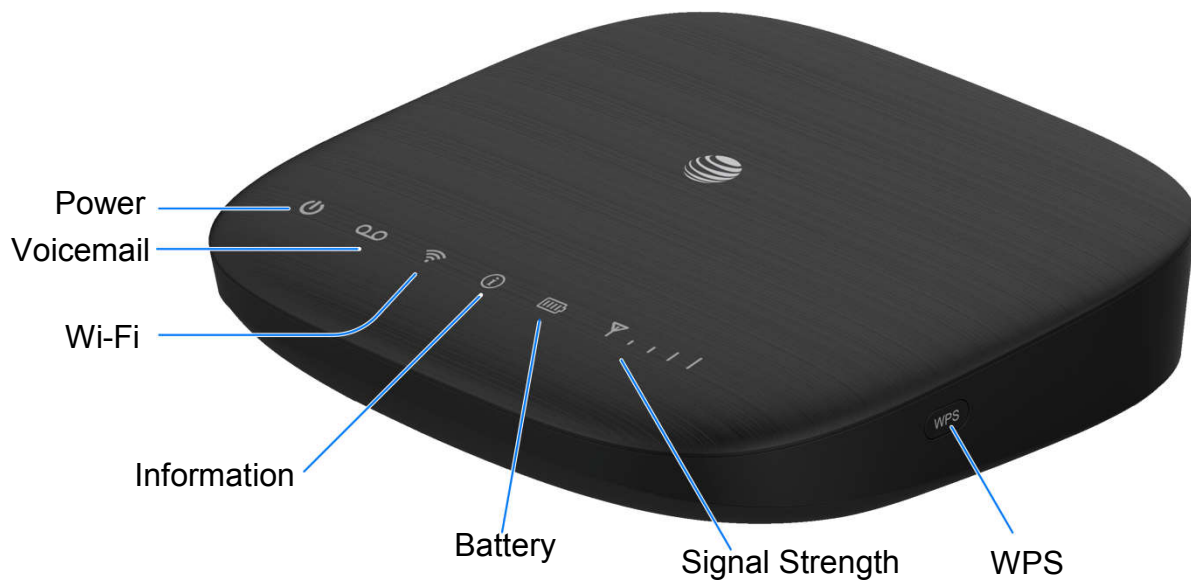

Getting to Know Your Device

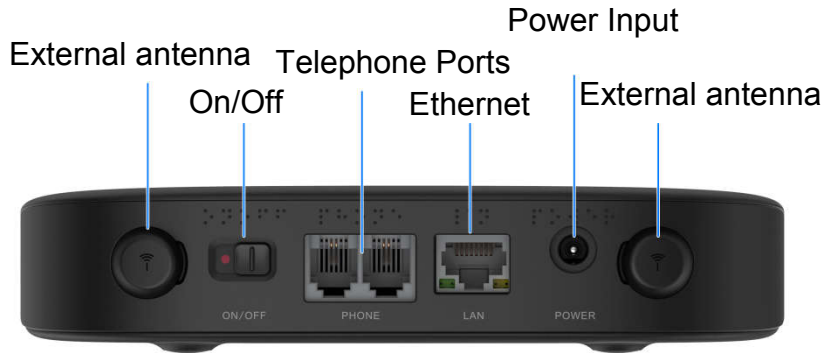
*Allows WPS-enabled devices to be connected via Wi-Fi without typing a Wi-Fi password. For detailed instructions, please refer to page 17.





Indicators

Indicator	State	Description
Power 	Green steady	On AC power
	Green blinking	On battery power
	Off	No power
Voicemail 	Green blinking	New voicemail waiting
	Off	No new voicemail
Wi-Fi 	Green steady	Wi-Fi on, no data transferring
	Green flickering	Data transferring
	Off	Wi-Fi off
Information 	Green blinking	Check the MF279 Web UI — New messages
	Off	No unread messages
Battery 	Green steady	More than 50% battery power
	Yellow steady	20%-50% battery power
	Red blinking	Less than 20% battery power
	Off	Battery needs to be installed or replaced

Signal Strength 	Blue steady	Strong signal 3G/4G/HSPA+(antenna and 1,2,3,4bars)
	Green steady	Strong signal LTE(antenna and 1,2,3,4bars)
	Red steady	No service, limited service, or searching for signal (antenna with RED and 0 bar)
	Red blinking	SIM checking, SIM error or other abnormal (antenna with RED and 0 bar . Blinking period: 2s)

How It Works

The AT&T Home Base uses the AT&T cellular network to provide phone service to your cordless or corded home phone(s) and Internet access to your computer and Wi-Fi enabled devices. Place it anywhere in your home where you have a strong wireless signal. It does not require the use of a home phone wall jack like traditional home phone service.

The AT&T Home Base provides many calling services, such as voicemail, Caller Number ID, Call Waiting, Call Forwarding, and Three-way Calling for your home phone(s). It also includes a back-up battery in case of a power outage.

Device Installation

Before You Begin

The AT&T Home Base works exclusively with the AT&T cellular network and DOES NOT use your home phone wall jacks.

Your device should be located:

- Where you have a strong signal from a cell tower, typically near a window or outside wall. Signal strength may vary in different parts of your home.
- Near an electrical wall outlet.
- In the general area where you'll be using your home phone, computer, or Wi-Fi enabled devices.

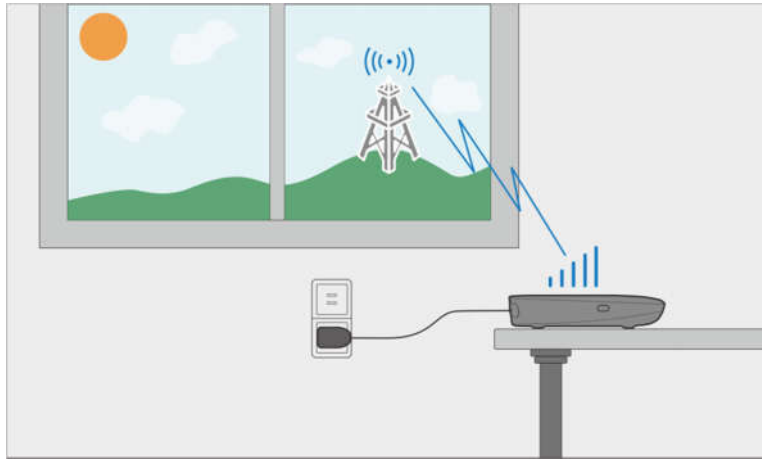

Select which phone and computer/Wi-Fi enabled device you will use with the AT&T Home Base:

- A cordless phone system with multiple handsets should be used to place phones throughout your home.
- If using an existing phone, unplug it from the wall jack.
- For Internet access, you may connect up to 20 devices via Wi-Fi and one via Ethernet simultaneously.

STEP 1: Set Up Your Device

Ⓐ Install the Back-up Battery and the nano-SIM Card(Optional)

1. Remove the bottom of the device by pushing the entire cover in the direction of the arrow.

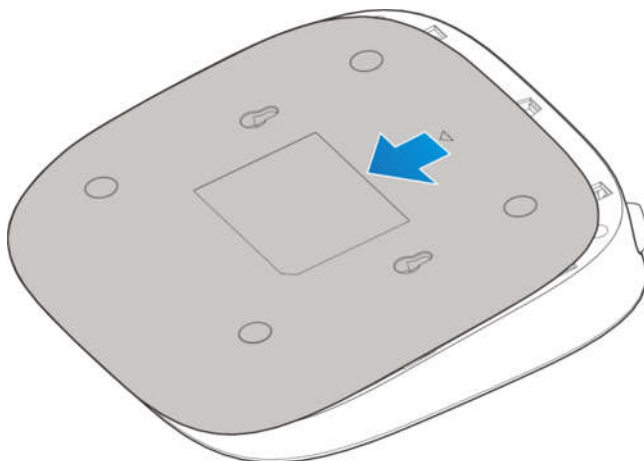

2. Install the nano-SIM card (Optional).

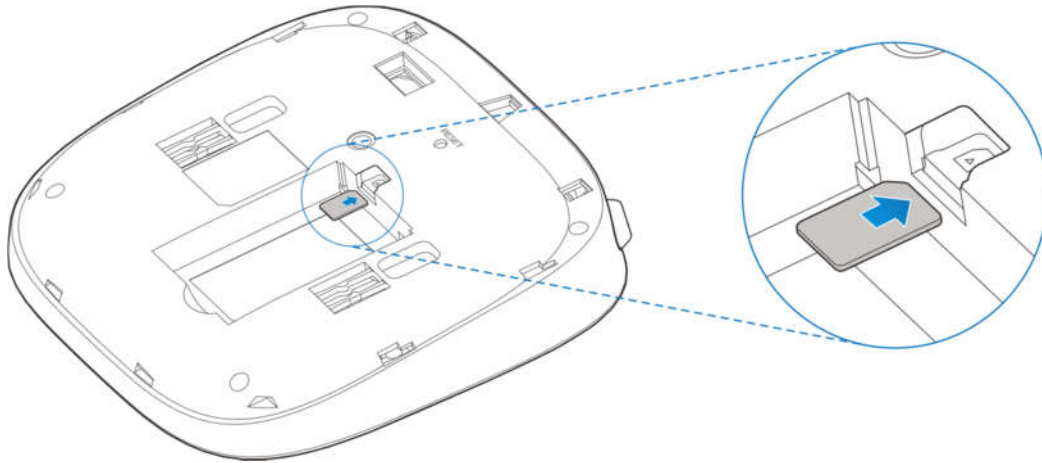

⚠ WARNING!

- Your device only supports a nano-SIM card.
- To avoid damaging the device, please only use the card that is provided by AT&T and ensure that the nano-SIM card contacts are facing up when inserting it into the nano-SIM slot.

2. Insert the back-up battery.

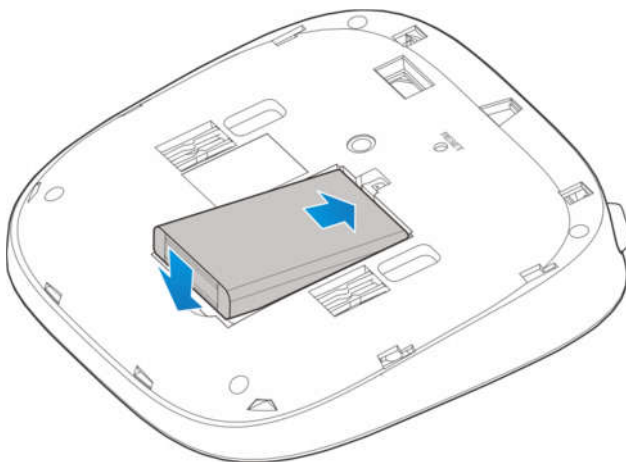

3. Replace the cover.

NOTES:

- The back-up battery is intended for backup purposes only and may take approximately eighteen (18) hours to fully charge.
- Charge time may be impacted by environmental factors and the back-up battery will stop charging when the ambient temperature is outside of the temperature range allowed for charging (0°C - 45°F).

ⓑ Turn on Your Device

1. Plug the power cord into an electrical wall outlet.
2. Connect the other end of the power cord into the Power Input port on the back of your AT&T Home Base.
3. Slide the **ON/OFF** button to the **ON** position and you'll see the power light stays steady green.

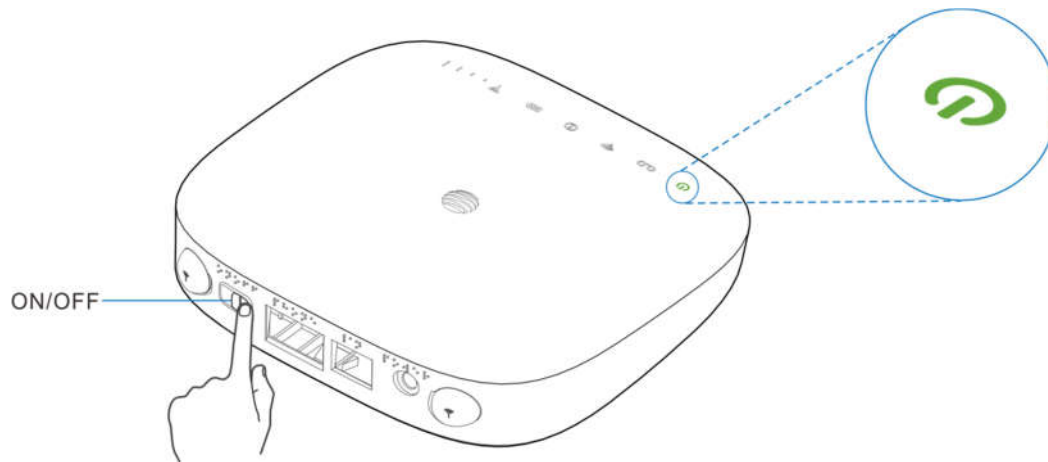

© Check the Wireless Signal

Wait a few seconds for the signal strength light to turn on, while your device connects to the cellular network.

Confirm signal strength light is blue for optimal performance. Green indicates a moderate signal and may be sufficient.

NOTE: If you do not see a blue/green light, you may want to choose another location in your home, such as near a window or outside wall.

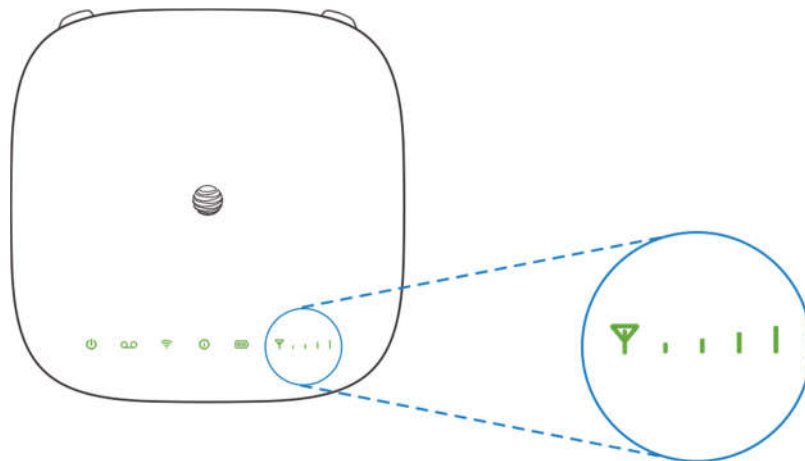

STEP 2: Connect Your Phone

Ⓐ Unplug your Phone from the Wall Jack

The AT&T Home Base is not used with your home phone wall jack.

NOTE: If you have a cordless phone, keep it plugged into a power outlet.

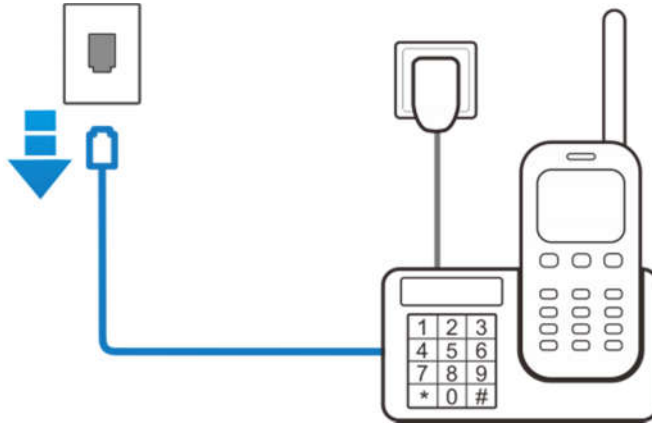

Ⓑ Connect your Phone to the Device

Plug your phone into the "Phone 1" port on the AT&T Home Base, using your existing phone cable or the included phone cable.

NOTE: Do not plug the AT&T Home Base or your phones into your wall jacks.

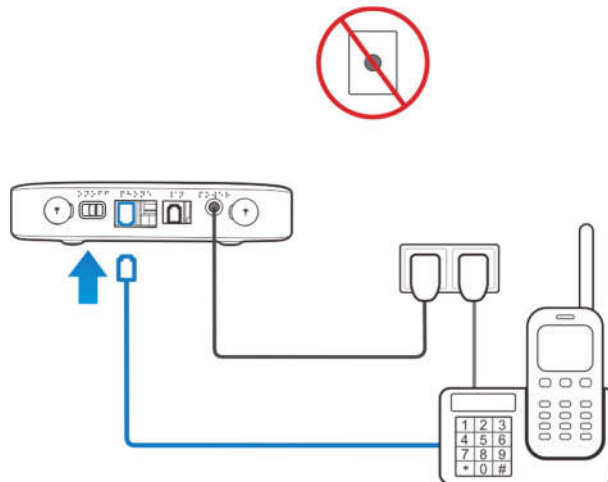

Ⓒ Place a Test Call

Place a test call from your connected home phone. Make sure to dial the 10-digit phone number, including area code.

For best results, place the cordless phone base at least 12 inches from the AT&T Home Base.

Important Phone Tips

- Voicemail is included with your service. Dial "1" to set up and access. If you choose to use an answering machine instead, set it to fewer than four (4) rings.
- To place phones throughout your home, use a cordless phone system with multiple handsets. Wall jacks are not used with the AT&T Home Base.
- The "Phone 2" port can be used to connect an additional phone or standalone answering machine. It uses the same phone number as the "Phone 1" port.

- Your AT&T Home Base does not support incoming/outgoing fax service or home alarm systems.
- Your AT&T Home Base does not support rotary or pulse-dialing phones.

Details on using voicemail and transferring a landline phone number can be found on pages 11-12.

STEP 3: Connect to the Internet

(A) *Select Your Internet Connection*

To Connect via Wi-Fi:

1. Open the Wi-Fi network manager on your computer or Wi-Fi enabled device.
2. Find and select the AT&T Home Base Wi-Fi network name (SSID) (e.g., ATT-WI-XXXX, ATT-WI-XXXX-GUEST).

To Connect via Ethernet:

Use an Ethernet cable (not included) to connect your computer or other device to the Ethernet port on the back of your AT&T Home Base. Go to **att.net** (or your favorite website) to confirm your Internet connection. Skip Steps 3B and 3C.

To connect via WPS, see page 17.

(B) *Enter Wi-Fi Network Password*

When prompted, enter the Wi-Fi password found on the bottom of the AT&T Home Base.

(C) *Confirm Internet Connection*

Go to **att.net** (or your favorite website) to confirm your Internet connection.

When your device is transmitting to and from the Internet, the Wi-Fi light will flicker green.

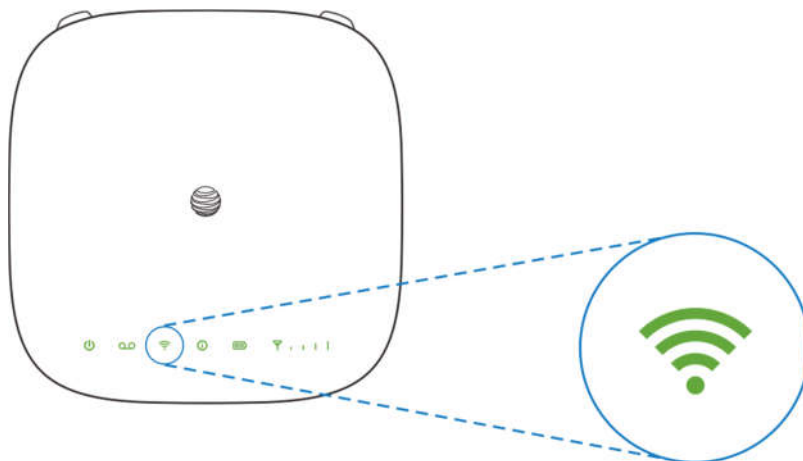

Important Internet Tips

- To check your data usage or manage your account, go to **att.com/myatt**.

- To customize your device settings, view important messages about your AT&T service plan, and check your data usage, use the **AT&T Home Base Manager**. On any device connected to the AT&T Home Base, enter **<http://att.wirelessinternet>** directly into your browser address field and use "attadmin" as your login.
- To setup a free AT&T email account, go to **att.net/signup** and select **Start Now**.

Voicemail

Your AT&T Home Base comes with standard wireless voicemail. Follow the steps below to setup and use your voicemail.

Setup

Dial **1** on any home phone connected to the AT&T Home Base and wait four (4) seconds to connect to your AT&T wireless voicemail. Simply follow the voice prompts to complete setup. To enable remote voicemail retrieval and for added security be sure to create a password during setup.

For more help on setting up your AT&T voicemail, go to **att.com/voicemailsetup**.

Message Waiting

There are two indicators for a new message waiting: 1) the voicemail icon; and 2) an intermittent dial tone.

The voicemail icon **LD** on your AT&T Home Base blinks when a voicemail message is waiting. You will also hear an intermittent dial tone on any connected phone handset before placing a call.

Retrieving Messages

To retrieve voice messages, dial **1** on any home phone connected to the AT&T Home Base and wait four (4) seconds to connect to your AT&T wireless voicemail box. Simply follow the voice prompts to listen to and manage your messages. (Alternately, you may dial your 10-digit home phone number to access your voicemail box.)

Remote Retrieval

To retrieve voicemail messages from a phone not connected to the AT&T Home Base, dial the number associated with your AT&T Home Base service. When voicemail picks up, press *****. You will then be prompted to enter your password. Simply follow the prompts to listen to and manage your voicemail messages.

Transferring a Phone Number

Transferring a landline phone number to your AT&T Home Base can take about four (4) days. Outgoing calls can be made immediately using your AT&T Home Base, however incoming calls (including 911) will continue through your old service until the transfer is complete. Keep a phone connected to your wall jack or prior service to continue to receive incoming calls until the transfer is complete. To check the status of your transfer, visit att.com/port.

AT&T Home Base Manager

The AT&T Home Base Manager allows you to easily manage your AT&T Home Base. You can:

- Customize settings
- Change your Wi-Fi network name and password
- Check signal strength, data usage, and important messages from AT&T
- Get help and information

To access the AT&T Home Base Manager, first connect to your AT&T Home Base. In your browser address field, enter <http://att.wirelessinternet> and log in using "attadmin" (Note: You can customize the login that is used to access the AT&T Home Base Manager by going to **Settings > Advanced > Administrator**).

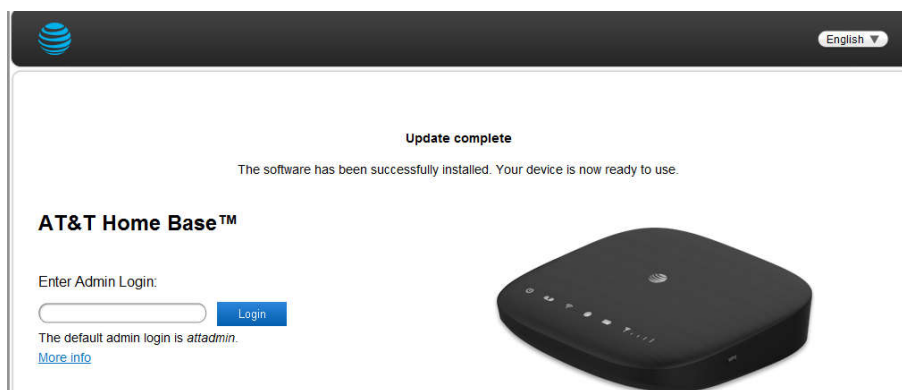

The AT&T Home Base Manager includes a navigation panel on the left side of the screen, which contains the following sections:

- **Home** -- displays general device information and help.
- **Connected Devices**-- view devices currently connected to your AT&T Home Base and block/unblock devices from connecting.
- **Data Used** -- check your billing month-to-date data usage and days remaining in your billing cycle.
- **Call Log** -- view incoming, outgoing, and missed calls placed to and from your AT&T Home Base.
- **Messages** -- view messages from AT&T about your service plan (See *Important Messages* on page 18).

- **Parental Control** -- Select a connected device to add to **Limited Device List**, you can also set the days and times to limit data access.
- **Settings** -- customize your device's Wi-Fi and security settings (See *Device Configuration* on page 28).
- **Run Device Diagnostics**-- Diagnosis the device basic status: network, Wi-Fi and firewall.
- **About Your Device** -- get details regarding current device status and information.
- **AT&T Software Update** -- view software updates that are delivered automatically over the AT&T cellular network.

Using Your Device

Calling

Making Calls

Using a phone connected to your AT&T Home Base, place and receive calls as you normally would. The AT&T Home Base supports both cordless and corded phone dialing methods.

Note: Make sure to dial the 10-digit phone number, including area code.

Three-Way Calling

While on an existing call, press the **Flash** (or **Phone/Talk**) key on your phone to put the first party on hold. When you hear a dial tone, dial the second party's number (wait up to four [4] seconds). When the second party answers, press the **Flash** (or **Phone/Talk**) key again to complete the three-way connection. If the second party does not answer, press the **Flash** (or **Phone/Talk**) key to end the connection and return to the first party.

Note: If your phone does not have a **Flash** (or **Phone/Talk**) key, use the off-hook mechanism supported by your phone instead.

Call Waiting

You will hear two tones if someone calls while you are already on a call.

To hold the current call and accept the waiting call, press the **Flash** (or **Phone/Talk**) key. You can press the **Flash** (or **Phone/Talk**) key anytime to switch back and forth between calls.

To clear the current call and accept the waiting call, enter "1" and press the **Flash** (or **Phone/Talk**) key.

To reject (User Busy) the waiting call, enter "0" and press the **Flash** (or **Phone/Talk**) key.

Notes:

- Your AT&T Home Base comes with standard three-way calling and call waiting. Operation of these features will vary depending on your home phone equipment.
- If your phone does not have a **Flash** (or **Phone/Talk**) key, then use the off-hook mechanism supported by your phone.

Call Forwarding

To forward all calls, dial:

1. ***21***
2. The 10-digit number to which you wish to forward your calls
3. **# key**

(Example: *21*1234567890# forwards your calls to the phone number 123-456-7890)

Please wait at least three (3) seconds and you hear a confirmation tone for the forwarding to complete before hanging up.

To un-forward calls, dial **#21#**, please wait at least three (3) seconds and you hear a confirmation tone for the un-forwarding to complete before hanging up.

Note: Applicable wireless minute plan rates apply to forwarded calls.

Call Log

You can view incoming and outgoing calls placed to and from your AT&T Home Base at att.com/myatt, or on the AT&T Home Base Manager. To view call details on the AT&T Home Base Manager, enter **http://att.wirelessinternet** directly into your browser address field on any device that is connected to your AT&T Home Base. Log in using "attadmin" (or your customized login) and go to **Call Log**.

Internet Access

Connect Other Devices

You can connect up to 20 Wi-Fi enabled devices simultaneously to your AT&T Home Base, including smartphones, tablets, laptops, etc.

1. Open the Wi-Fi network manager on your Wi-Fi enabled device.
2. Find and select the Wi-Fi network name (SSID) **ATT-WI-XXXX / ATT-WI-XXXX-GUEST**.

Note: Your device support 2.4G wireless network and 5G wireless network. You can connect to 10 Wi-Fi enabled devices in 2.4G network and connect to 10 Wi-Fi enabled devices in 5G network simultaneously.

3. When prompted, enter the Wi-Fi password found on the bottom of the AT&T Home Base.

Connect WPS devices

Wi-Fi Protected Setup (WPS) allows WPS-enabled devices to be connected to a Wi-Fi network without having to type a Wi-Fi password.

1. With the AT&T Home Base powered on, press and hold the WPS button for one (1) second.
2. Within two (2) minutes, press the WPS button on the wireless device you want to connect.
3. Your AT&T Home Base and the wireless device will communicate and establish the connection.

Connect via Ethernet

To connect via Ethernet, plug one end of your Ethernet cable into the Ethernet port on your computer and the other end into the Ethernet port on the back of the AT&T Home Base.

Changing Wi-Fi Network Name and Password

You can customize your AT&T Home Base Wi-Fi network name (SSID) and password using the AT&T Home Base Manager. On any device that is connected to the AT&T Home Base, enter **http://att.wirelessinternet** directly into your browser address field and log in using "attadmin" (or your customized login). Go to **Settings > Wi-Fi > Basic** to change your network name and **Settings > Wi-Fi > Security** to change your password.

Note: You will need to reconnect all Wi-Fi devices using the new information.

Important Messages

Your AT&T Home Base is able to receive important messages from AT&T regarding new software updates and your service plan. You are not able to respond or reply to these messages.

To view your messages, use any device that is connected to the AT&T Home Base and enter **http://att.wirelessinternet** directly into your browser address field. Log in using "attadmin" (or your customized login), and go to **Messages**.

Managing Connected Devices

You can view devices currently connected to your AT&T Home Base and block and unblock devices using the AT&T Home Base Manager. On any device that is connected to the AT&T Home Base, enter **http://att.wirelessinternet** directly into your browser address field. Log in using "attadmin" (or your customized login), and go to **Connected Devices**.

Parental Control

With Parental Control, you can block inappropriate and dangerous sites, restrict access by time, and at the same time protect every device on your home network against adware and phishing through one central point- your AT&T Home Base.

You can select a connected device add to Limited Device List. Select days and times to limit data access.

To the limited device list, use any device that is connected to the AT&T Home Base and enter **http://att.wirelessinternet** directly into your browser address field. Log in using "attadmin" (or your customized login), and go to **Parental Controls**.

Checking Your Voice and Data Usage

You can check your voice and data plan usage for your current billing cycle by either downloading the free **myAT&T™** app to your smartphone or tablet, or visiting **att.com/myatt** on your computer. To download the myAT&T app, go to your device's app store or go to **att.com/myattapp** from your smartphone or tablet. Data and messaging rates may apply.

You will need to log in to manage your account and review usage details.

If you don't already have a user ID and password, select [Create one now](#) (on a computer) or [Register](#) (on the myAT&T app).

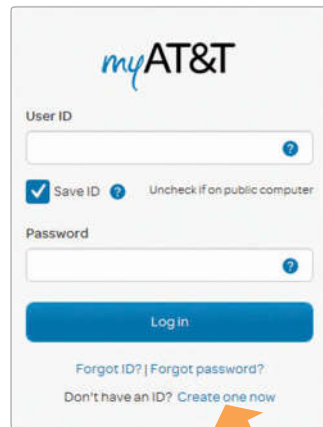

Then follow these steps:

- Enter your AT&T phone number or Account number and billing zip code.
- If prompted, enter additional verification information.
- If you receive a validation code, enter it.
- You may be prompted to indicate whether you are the account owner, meaning your name is on the bill. If you don't own the account, provide the account information to gain access.
- Create your **User ID** and **Password**.
- Agree to the **Terms & Conditions**.

You can view your voice and data usage once you have logged in to your account. You may need to select the tab for your wireless plan and **View all usage** to see the usage details for your AT&T Home Base phone number.

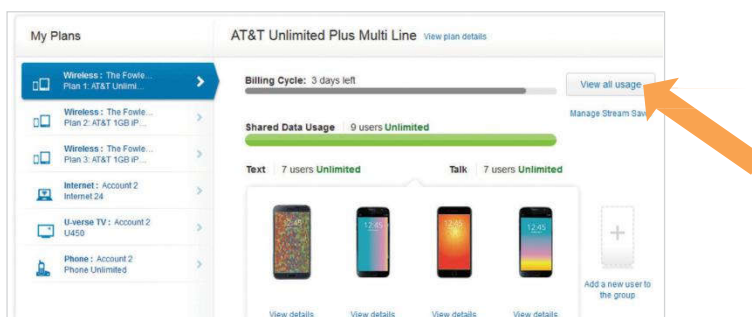

If you did not provide an email address for email notifications when you purchased your AT&T Home Base, you can do so at att.com/myatt. Once you have logged on to your account, go to Profile and enter a valid email address. You will receive email notifications when you are approaching your data plan limit or if you have exceeded your data plan limit. If you have a limited voice plan, you will also receive notifications as you are approaching your voice plan limit or if you have exceeded your voice plan limit. You can also use the AT&T Home Base Manager to check your data plan usage and view data usage notifications. On any device that is connected to your AT&T Home Base, enter <http://att.wirelessinternet> directly into your browser address field. Log in using "attadmin" (or your customized login). To check your data usage and the days remaining in your billing cycle, go to **Data Used**. To view data usage notifications, go to **Messages**. The "i" light on your AT&T Home Base will blink green when you have a new notification.

Note: Actual billed usage can be higher than the estimated data usage displayed in the usage meter.

Helpful Tips

Home Answering Machines

If you choose to use your home answering machine instead of the voicemail provided by your AT&T Home Base, you will need to set your answering machine to pick up calls before network voicemail, which is fewer than four (4) rings. If you have a standalone answering machine, you can connect it to the "Phone 2" port on the back of your AT&T Home Base.

Alternatively, you can call AT&T Customer Service at 1-800-331-0500 to turn off the network voicemail feature.

Adjusting Volume

Use your home phone's volume adjustment if available. Alternatively, the volume of the AT&T Home Base can be adjusted. Six volume levels are available (level 1 to level 6) with the default setting at level 3. While on a call, press ** to decrease volume or press ## to increase volume. Each time ** or ## is pressed, the volume level is decreased or increased one volume level. To exit Volume Setting Mode, press any other key or wait five (5) seconds.

Powering On/Off

The **ON/OFF** button is used to turn your AT&T Home Base on or off. When powered off, the AT&T Home Base will no longer send or receive calls, but it will continue to charge the back-up battery if still connected to the wall outlet.

To turn on your AT&T Home Base, slide the **ON/OFF** button to the **ON** position until the power light stays solid green, if connected to a power supply (it will blink green if on back-up battery). To turn off your

AT&T Home Base, slide the **ON/OFF** button to the **OFF** position until all the lights turn off.

TTY Support

TTY (Text Telephony) and TDD (Telecommunications Device for the Deaf) are supported by the AT&T Home Base. In order to use the TTY network, you must have a TTY-compatible phone and be in TTY mode. Note that most digital wireless devices are TTY-compatible.

Dial *983*889*n# to set the TTY mode.

- n = 0: TTY off mode. The standard voice speaking mode and listening mode. This is the default setting.
- n = 1: TTY full mode. Transmit and receive the TTY characters.
- n = 2: VCO mode. Receive TTY characters but transmit by speaking into the speaker.
- n = 3: HCO mode. Transmit TTY characters but receive by listening to the receiver.

Important Information

E911 Service

For emergency calls, you may have to provide your location address to the 911 operator.

Power Outages

The AT&T Home Base has a back-up battery in the event of a power outage with talk time of approximately 100 minutes and standby time of approximately 18 hours depending on environmental factors. In the event of a power outage (commercial power no longer being available), the AT&T Home Base will automatically begin using the back-up battery, provided there is sufficient battery charge left. If there is no battery charge at the time of the power outage, the device will not be operable.

To make calls using your back-up battery, you must plug a corded phone or landline phone into the "Phone 1" or "Phone 2" port on the AT&T Home Base.

The AT&T Home Base will disable Wi-Fi to conserve power while using the back-up battery when there are no devices connected. To re-enable Wi-Fi while using the back-up battery, slide the **ON/OFF** button to the **ON** position. Or, if power is available, plug the AT&T Home Base into an electrical wall outlet.

If you experience a power outage and your back-up battery is fully depleted, it will be necessary to restart your device when power is restored by sliding the **ON/OFF** button to the **ON** position until the power light stays solid green.

Back-up Battery

A new back-up battery should last for approximately 5 years, but the life of any back-up battery can be adversely affected by environmental conditions like moisture and heat. To get the longest service from

your back-up battery, do not place the AT&T Home Base in direct sunlight or in wet or extremely cold environments.

To test the condition of your back-up battery, make sure the AT&T Home Base is powered on. Unplug the AT&T Home Base from the wall power outlet. If the Power LED immediately starts blinking red, then the back-up battery may need to be replaced. If the AT&T Home Base does not remain on (no LEDs are lit) once unplugged from the wall power outlet, then the back-up battery needs to be replaced.

It is recommended that you test your back-up battery charge at least once per year and replace if necessary.

To order a replacement back-up battery and for cost and warranty information, visit **att.com** and search **Home Base battery**.

Device Compatibility

The AT&T Home Base is not compatible with wireless messaging services, home security systems, fax service, medical alert systems, medical monitoring systems, credit card machines, IP/PBX Phone systems, or dial-up Internet service. May not be compatible with your DVR/Satellite systems, please check with your provider. DSL customers should contact their provider before transferring a phone number to ensure uninterrupted DSL Internet service.

The AT&T Home Base cannot be used to make 500, 700, 900, 976, 0+ collect, operator-assisted, or dial-around calls (e.g. 1010-XXXX).

In-Home Wiring

Interconnecting to home telephone wiring is not necessary, but is possible; however, it is not recommended unless you possess sufficient knowledge of electrical systems. Use with home wiring requires the physical disconnection from other services, including the landline coming into your home. Use of a qualified licensed electrician is highly recommended. Improper installation may result in phone equipment damage or even a fire.

Frequently Asked Questions

What kind of phone do I need to work with the AT&T Home Base?

Most standard touch-tone phones may be used. Rotary phones are not supported. Cordless phone systems provide the most flexibility and allow you to easily place additional handsets throughout your home. Cordless phone systems still need to be plugged into a power outlet. A standard corded phone can be used if you just need one phone in your home.

During a power outage, a standard corded phone which doesn't require electrical power is needed.

How do I install my AT&T Home Base?

Refer to pages 8-14 of this guide for the most common installation methods. Other helpful information:

- Installation near a window or outside wall is strongly recommended to ensure the strongest possible

wireless signal in order to maximize voice/data performance.

- If the AT&T Home Base signal strength indicator does not display high signal strength (Blue) or voice/data performance is unacceptable, you may need to relocate the device to another part of the home with a stronger wireless signal.

Will my AT&T Home Base work in areas with no or low wireless signal strength?

A strong wireless signal (Blue) is recommended for optimal performance. A moderate signal (Green) may be sufficient. If you do not see a blue/green light, you may want to choose an alternate location.

Does the AT&T Home Base support both voice and data?

Yes, you can use your AT&T Home Base for both voice and data, as long as you subscribe to AT&T Wireless Home Phone and Wireless Home Internet plans for the Home Base.

Why don't I see the name of the caller on caller ID?

The AT&T Home Base, similar to other wireless devices, supports calling number identification. However, contact names stored on your cordless home phone may display for incoming calls.

Can I move my AT&T Home Base and use it in another location?

Yes, you can use your device anywhere in the U.S. where AT&T is authorized to provide wireless services. All you need is a power outlet and strong AT&T wireless signal.

When I dial a seven-digit number using the AT&T Home Base, I get a message that the number cannot be completed as dialed. Does the AT&T Home Base support seven-digit dialing?

The AT&T Home Base requires 10-digit dialing for domestic calls in most areas.

Can I make international calls with my AT&T Home Base?

Yes. To add international calling to your account, please call 611 from your connected phone, or 1-800-331-0500.

Can I use my AT&T Home Base internationally?

No. Use is limited to the United States, Puerto Rico, and U.S. Virgin Islands.

What is the warranty on the AT&T Home Base?

The AT&T Home Base has a 12-month limited warranty. For details, see page 37.

I can't make or receive calls with my AT&T Home Base. What should I do?

Please follow the troubleshooting steps in this User Guide. If further assistance is required, call 1-800-331-0500.

How many devices can I connect to my AT&T Home Base?

There are two phone ports to connect your phone or answering machine. For data, you can connect up to 20 devices via Wi-Fi simultaneously and one device via Ethernet.

How can I check my data speed?

You can check your data speed by visiting att.com/speedtest.

Will connecting additional devices affect my data speed?

Yes, active use of multiple devices will decrease your data speeds.

Can I change my Wi-Fi network name and password?

Yes, you can change your Wi-Fi network name and password using the AT&T Home Base Manager. From any connected device, enter **http://att.wirelessinternet** directly into your browser address field and log in using "attadmin" (or your customized login). Go to **Settings > Wi-Fi > Basic** to change your network name and **Settings > Wi-Fi > Security** to change your password.

How do I know how much data I've used?

To check your data plan usage for your current billing cycle, go to **att.com/myatt**. You can also view your data usage and the days remaining in your billing cycle using the AT&T Home Base Manager. From any connected device, enter **http://att.wirelessinternet** directly into your browser address field and log in using "attadmin" (or your customized login), and go to **Data Used**.

Once I've reached the maximum amount of data in my plan, can I continue to use my AT&T Home Base for data?

Yes, but overage charges will apply. To upgrade your data plan, visit **att.com/myatt**.

Troubleshooting

General

Problem	Possible Solution
None of the LEDs are illuminated	<ul style="list-style-type: none"> Make sure there is AC power to the AT&T Home Base. Do not connect to an AC outlet controlled by a wall switch. Slide the ON/OFF button to the ON position on the back of the AT&T Home Base until the Power light stays solid green.
Red signal strength indicator	<ul style="list-style-type: none"> Move your device to another area with sufficient network signal (Green or Blue Signal Strength light).
Blinking Red signal strength indicator	<ul style="list-style-type: none"> nano-SIM card is missing or not installed properly. <ol style="list-style-type: none"> Remove the bottom of the device and back-up battery. Locate the nano-SIM card slot and insert the nano-SIM card into the slot until secure. The nano-SIM card will click and lock in place when properly installed in the correct orientation. nano-SIM card may be invalid or damaged and need to be replaced. For a replacement nano-SIM card, take your AT&T Home Base to your local AT&T store. Or, call AT&T Customer Care at 1-800-331-0500.
nano-SIM Card doesn't work in my mobile device	The nano-SIM card provided with your AT&T Home Base is intended for use only in your specific AT&T Home Base and cannot be used in a mobile handset.

Phone

Problem	Possible Solution
No dial tone	<ul style="list-style-type: none"> • Make sure there is AC power to the AT&T Home Base. Do not connect to an AC outlet controlled by a wall switch. • Make sure your AT&T Home Base is powered on. Slide the ON/OFF button to the ON position until the Power light stays solid green. • Make sure your cordless phone has power and is connected properly to the AT&T Home Base. • Move the AT&T Home Base to an area with sufficient network signal (Blue or Green Signal Strength light).
Caller Number ID only	<ul style="list-style-type: none"> • Like all wireless services, only the calling number is displayed with Caller ID. • Your home phone may support the display of names stored in its contacts memory.
My answering machine won't pick up calls	<ul style="list-style-type: none"> • Set your answering machine settings to pick up calls before network voicemail, which is approximately four (4) rings. • Or, you can have network voicemail removed from your account by calling AT&T Customer Care. Dial 611 from your connected phone or 1-800-331-0500.
Poor voice quality	<ul style="list-style-type: none"> • Use the phone cable included with the AT&T Home Base. • Make sure all connections are firmly in place. • Move your AT&T Home Base to an area with sufficient network signal (Blue or Green Signal Strength light). • Increase the distance away from other electronic devices and the AT&T Home Base (including cordless base stations, Wi-Fi routers, and cell phones). • Move the AT&T Home Base near a window with a clear unobstructed view of the sky and remove any objects that may be obstructing the wireless signal. • Make sure the home phone that is connected to the AT&T Home Base is of good quality and in good working order. • Voice quality may degrade with a low battery charge. Connect to an AC power source to recharge when power is available.
Message Waiting indicator on my home phone doesn't light	<ul style="list-style-type: none"> • The AT&T Home Base does not support this functionality with your home phone. • The AT&T Home Base has a dedicated voicemail light that will blink when you have a new voice message; you will also hear an intermittent

	dial tone when you pick up your handset.
I hear an intermittent dial tone	<ul style="list-style-type: none"> You will hear an intermittent dial tone when you have a new voicemail message waiting. Dial 1 from your home phone that is connected to the AT&T Home Base to listen to your voice messages.
My phone doesn't ring when a call comes in	<ul style="list-style-type: none"> If you recently transferred your landline phone number, you will continue to receive incoming calls on your previous service until the transfer is complete. To check transfer status, visit att.com/port. Make sure your AT&T Home Base is NOT connected to your in-home phone wiring. Make sure your home phone is powered on and connected to the AT&T Home Base. Your AT&T Home Base number may be set to Call Forward. Dial #21# to un-forward calls.
I hear a constant low frequency tone (not dial tone) when I try to place a call	<ul style="list-style-type: none"> Hang up your home phone to restore dial tone.

Internet

Problem	Possible Solution
Can't access the Internet	<ul style="list-style-type: none"> Make sure your AT&T Home Base is powered on. Slide the ON/OFF button to the ON position until the Power light stays solid green. For Wi-Fi: Make sure your AT&T Home Base is located in the general area of your Wi-Fi enabled device(s). Check that your device is connected to the AT&T Home Base Wi-Fi network (e.g. ATT-WI-XXXX) and you are using the correct Wi-Fi Password. For Ethernet: Make sure the Ethernet cable is securely inserted into the Ethernet port on the back of the AT&T Home Base and your computer (or other device). Move the AT&T Home Base to an area with sufficient network signal (Green or Blue Signal Strength light). Make sure the Wi-Fi light is on. If not, restart your AT&T Home Base. Slide the ON/OFF button to the OFF position until all lights turn off. Then, Slide the ON/OFF button to the ON position until the power light stays solid green. Check the following on the AT&T Home Base Manager (http://att.wirelessinternet) Under Settings > Wi-Fi > Basic: "Wi-Fi Broadcast" is set to "On" Under Settings > Network > APN: Profile selection is set to "ATT Nextgenphone"

	<ul style="list-style-type: none"> • Under Settings > Firewall > Mac/IP/Port Filtering: Check that the IP and MAC address of your device are not blocked by the firewall.
Download or upload speeds are slow	<ul style="list-style-type: none"> • Check your speed at att.com/speedtest. • Check your signal strength light. If not green or blue, choose an alternate location. • Other connected devices may be transferring a large amount of data. To view and block other connected devices, go to the AT&T Home Base Manager (http://att.wirelessinternet) under Connected Devices. • A phone call in progress may slow down the data speed. • Check your wireless network connection using the AT&T Home Base Manager (http://att.wirelessinternet). 4G LTE offers the fastest data speeds and if available, the AT&T Home Base should be located in a covered area.
The AT&T Home Base Network does not appear in the wireless network list	<ul style="list-style-type: none"> • Make sure the AT&T Home Base is powered on. Power light should be solid green/blue if connected to a power outlet (or blinking green if on back-up battery). • Refresh the network list on the device you are trying to connect. • Restart your AT&T Home Base: Slide the ON/OFF button to the OFF position until all lights turn off. Then, Slide the ON/OFF button to the ON position until the power light stays solid green.
Can't connect to my AT&T Home Base	<ul style="list-style-type: none"> • Check that you are connecting to your AT&T Home Base Wi-Fi network name (SSID) (e.g. ATT-WI-XXXX). If connected via Ethernet, make sure the Ethernet cables are firmly attached. • Make sure you entered the correct Wi-Fi password found on the bottom of your device or your customized password, if you changed it.
Can't access the AT&T Home Base Manager	<ul style="list-style-type: none"> • Make sure you are trying to access on a device that is currently connected to your AT&T Home Base either via Wi-Fi or Ethernet connection. • Make sure you have entered the correct URL (http://att.wirelessinternet or http://192.168.0.1) directly into your browser address field on your connected device. • Make sure you have entered the correct login, either "attadmin" or your customized login. If you changed the login and forgot it, you will need to restore the device to the factory default settings. Remove the bottom cover of your device and using a ballpoint pen, press and hold the RESET button for five (5) seconds. You may then log in using the default login "attadmin."

Device Configuration

You can manage your AT&T Home Base settings using the AT&T Home Base Manager. To access, first connect to your AT&T Home Base and enter **http://att.wirelessinternet** directly into your browser address field. Log in using "attadmin"(or your customized login).

Wi-Fi Settings

You can manage your AT&T Home Base Wi-Fi Settings under **Settings > Wi-Fi**.

Basic

Wireless Networks ?

2.4GHz Main SSID

Network Mode	802.11 b/g/n
Network Name (SSID) *	<input type="text" value="ATT-WI-7195"/>
Broadcast Network Name (SSID)	<input checked="" type="radio"/> Enable <input type="radio"/> Disable
Frequency (Channel)	<input type="text" value="Automatic"/>

5GHz Main SSID

Network Mode	802.11 a/n/ac
Network Name (SSID) *	<input type="text" value="ATT-WI-7195"/>
Broadcast Network Name (SSID)	<input checked="" type="radio"/> Enable <input type="radio"/> Disable
Frequency (Channel)	<input type="text" value="Automatic"/>

Network Mode: Indicates which mode is active for connecting via Wi-Fi. The default is 802.11b/g/n Mixed Mode for 2.4G network, and 802.11 a/n/ac Mixed Mode for 5G network.

Network Name (SSID): Shows the Wi-Fi network name (SSID), which is broadcast by the device to allow Wi-Fi enabled devices to identify and connect to it. You can change the Network Name by typing the desired name directly into the text box.

Broadcast Network Name (SSID): If this setting is enabled, the AT&T Home Base appears in the list of available Wi-Fi networks on your Wi-Fi enabled devices. If disabled, the network will not appear.

Frequency (Channel): This should be left on Automatic unless you need to choose a particular channel

for your environment.

The image shows two sections of a web interface for configuring Wi-Fi settings. The top section is titled "2.4GHz Main and Guest Wi-Fi Max Devices". It states "A total of 10 devices can connect." Below this, there is a "Max Wi-Fi" dropdown menu set to "10". Underneath, there are two sub-sections: "Main Wi-Fi" with a plus sign icon and a value of "5", and "Guest Wi-Fi" with a plus sign icon and a value of "5". A blue "Apply" button is located to the right of these settings. The bottom section is titled "5GHz Main and Guest Wi-Fi Max Devices" and has an identical layout with a total of 10 devices, a "Max Wi-Fi" dropdown set to "10", and sub-sections for "Main Wi-Fi" (5) and "Guest Wi-Fi" (5), each with a plus sign icon and an "Apply" button.

Maximum Wi-Fi Devices: Specify how many devices can simultaneously connect to the AT&T Home Base.

Be sure to click "Apply" after you've made changes.

Connections

View devices that are currently connected to your AT&T Home Base and block and unblock devices from having access.

The following information is displayed for each connected device:

Device Name: If you have assigned a name to the connected device, the assigned name will appear. If the device name is unavailable, you will need to refer to the MAC Address to identify your device.

MAC Address: A unique network identifier for the connected device.

IP Address: IP address of the connected device.

Block a Device: Checking the "Block Access" box and clicking "Apply" disconnects the connected device and prevents it from re-connecting to the AT&T Home Base. The blocked device will then appear in the Blocked Wi-Fi devices list.

Blocked Wi-Fi Devices List: Lists any devices you have blocked from having access to your AT&T Home Base. Note that since these devices are not currently connected and are blocked from connecting, they do not have an IP address. Instead, they are identified by their MAC Address.

Unblock: Checking the "Unblock Access" box and clicking "Apply" unblocks a previously blocked device, freeing it to connect to the AT&T Home Base again. The unblocked device is deleted from the Blocked Wi-Fi devices list and will reappear in the Connected Devices list when it connects.

Security

Security settings will apply to all connected devices. If you change these settings, existing connected devices may lose their connection.

Security Policy ?

2.4GHz Main Security

Security Mode WPA-PSK/WPA2-PSK ▼

WPA (Wi-Fi Protected Access)

Wi-Fi Password (Network Key) * 78670177

Password Visibility On Off

*Note: After you click **Apply**, all connected Wi-Fi devices will need to reconnect.*

Apply

Security Mode: Select the desired Wi-Fi security option.

WPA-PSK/WPA2-PSK is the latest and most secure method and should be used if possible. **NO ENCRYPTION** allows other people to monitor your Wi-Fi traffic and use your data plan to access the Internet. If at all possible, its use should be avoided.

Wi-Fi Password (Network Key): If WPA-PSK/WPA2-PSK was selected in the Security Mode field, a Wi-Fi password is displayed. This password will need to be entered on any device needing to connect to the AT&T Home Base via Wi-Fi. You can change the Wi-Fi password by typing a new password directly into the text box.

Password Visibility: If this setting is enabled (On), the Wi-Fi password is readable on the screen. If disabled (Off), the password appears as

WPS

WPS, or Wi-Fi Protected Setup, is a standard that allows easy establishment of a secure wireless home network. This feature is set to Enable by default. If you change these settings, existing connected devices may lose their connection.

WPS: You may **Enable** or **Disable** WPS by selecting the desired option and clicking "Apply" When enabled, the following secondary options will appear:

WPS Mode: You may select either **PIN** or **PBC (Push-Button Connection)** by selecting the desired option and clicking "Apply".

PIN: If selected, you will need to specify a 4-digit or 8-digit PIN that other devices will require to connect via this method. Enter the desired PIN in the field, then click "Apply".

PBC: If selected, this will act in the same way as manually pushing the WPS button on the back of the AT&T Home Base. Within two (2) minutes, you will need to activate WPS on the device you wish to connect to the AT&T Home Base via a physical or virtual button in order to complete the connection process.

Note: Refer to your connecting device's documentation for specific information on how to complete the WPS process on the desired device.

Network

These settings affect the connection to the mobile (wide area) network or WAN.

Connections

The AT&T Home Base automatically selects the optimal mobile network.

The screenshot shows the 'Mobile Networks' settings page. At the top, there is a header 'Mobile Networks' with a help icon. Below it, a note states: 'Enable mobile data services such as email, web browsing and push notifications over the cellular network. Data charges may apply.' There are two toggle switches: 'Mobile Data' is currently turned 'On' (indicated by a blue dot), and 'Enhanced LTE Services' is currently turned 'Off' (indicated by a grey dot). Each toggle has an 'Apply' button to its right. Below the toggles, another note says: 'Enable HD Voice and advanced communication services where available.' Underneath, the 'Signal Strength' section is visible, showing 'Network Connection' as 'No Service' and 'Signal Strength' as a bar graph (partially obscured).

Mobile Data: You can set whether to enable or disable data access on your AT&T Home Base.

Enhanced Voice Services: Enables enhanced voice and communications over the cellular network (where available). Data charges may apply.

Signal Strength: Indicates the type of network connection the AT&T Home Base is currently using. There is also a Signal Strength value based on current conditions.

Firewall

A firewall protects your connected devices against malicious incoming traffic from the Internet. The firewall cannot be disabled, but the following settings are available.

MAC/IP/Port Filtering

You can **Enable** or **Disable** the MAC/IP/Port Filtering feature as needed to block certain Internet traffic. If this setting is enabled, you can then choose whether traffic is **Accepted** or **Dropped** by default by selecting the appropriate option from the Default Policy dropdown.

Default Policy:

Accepted: Internet traffic is allowed by default. Only traffic from the selected applications will be blocked from accessing the Internet. Traffic is identified by port numbers. Some applications are pre-defined. You can define additional applications by clicking the "Add Custom Application" button, but you need to know details of the traffic used and generated by the applications you wish to define. In particular, you need to know the port numbers and the protocol (TCP, UDP) used by outgoing traffic.

Dropped: Internet traffic is blocked by default. Only traffic from the selected pre-defined or custom applications are allowed to access the Internet.

Applications: Use these check boxes to deny or allow access to the Internet for each application, as an exception to the selected Default Policy of accepting or dropping Internet traffic.

Custom Applications: This feature allows you to define your own applications. Once defined, these applications can be enabled and disabled the same way as pre-defined applications. To define an application, you need to know the ports and protocol (TCP, UDP) used by the application for outgoing

traffic. To start, click the **Add Custom Application button**, then provide the following data:

MAC Address: A network identifier unique to each device's hardware.

Destination IP Address: The internal IP address where traffic will be filtered to.

Source IP Address: The source IP address that traffic will be filtered from.

Protocol: You can select from **None/TCP/UDP/ICMP** as the traffic type you would like to filter.

Destination Port Range: The range of ports that traffic will be filtered to. Enter the beginning and end of the port range for each application.

- For a single port, enter the port number in both fields.

- For a port range, enter the beginning of the range in the first field and the end of the range in the second field.

Source Port Range: The range of ports that traffic will be filtered from.

Action: Selecting **Drop** or **Accept** will determine if the rule will allow or block traffic based on the criteria specified.

Comment: Here you will need to add a name or description to the rule in order to click **Apply** to save and implement the rule.

Port Forwarding

Port Forwarding allows for specific external ports on the AT&T Home Base to be mapped to specific ports on a specific device on the internal network. You can have a maximum of 10 Port Forwarding/Virtual Server rules in the system.

You can **enable** or **disable** Port Forwarding to allow certain devices to act as virtual servers within the internal AT&T Home Base network.

If you select Enable, the Virtual Server Settings will appear:

IP Address: Enter the internal IP address (i.e. 192.168.1.101) that you would like traffic from a specific external port directed to internally.

Port Range: Enter the starting and ending port numbers that will be directed to the internal device.

Protocol: You may pick **TCP**, **UDP**, or **TCP+UDP** traffic types to be directed.

Comment: Enter a comment or label to be saved with this custom port forwarding rule.

Be sure to click "Apply" to confirm your configuration.

DMZ

The DMZ, or De-Militarized Zone, is a selected internal IP address of a device that allows full access and connectivity from outside traffic, through the firewall, to a specific internal device without being filtered or blocked by the AT&T Home Base.

DMZ Settings: You may choose to enable or disable the DMZ setting here. DMZ is set to Disable by default.

DMZ IP Address: Enter the internal IP address of the desired device that will be directly accessible from outside the firewall.

Advanced

Administrator

This page allows you to change the default login (attadmin) that is used to access the AT&T Home Base Manager.

Administrator Settings for AT&T Home Base Manager 

Current Login *	<input type="text"/>
New Login *	<input type="text"/>
Verify New Login *	<input type="text"/>
Login Visibility	<input checked="" type="radio"/> On <input type="radio"/> Off
Change Language	<input type="text" value="English"/>

Current Login: Enter the current login for the AT&T Home Base Manager in this field. The default login is "attadmin."

New Login: Enter the new login, using only letters, numbers, and standard punctuation symbols. The password must be at least four (4) characters long. The maximum length is 32 characters.

Verify New Login: Re-enter the new login in this field, then click "Apply."

Note: Once you change the default login, there is no way to retrieve the new login. You must reset the AT&T Home Base to its factory settings to restore the login to the default login "attadmin." Remove the bottom cover of your AT&T Home Base and using a ballpoint pen, press and hold the RESET button for five (5) seconds.

Login Visibility: If this setting is enabled (On), the Login is readable on the screen. If disabled (Off), the Login appears as •••.

Router

Router Settings 

IP Address *	<input type="text" value="192.168.0.1"/> (eg: 192.168.1.101)
Subnet Mask *	<input type="text" value="255.255.255.0"/>
MAC Address	00:88:88:88:88:88
DHCP Server	<input checked="" type="radio"/> Enable <input type="radio"/> Disable
DHCP IP Pool *	<input type="text" value="192.168.0.100"/> - <input type="text" value="192.168.0.200"/>
DHCP Lease Time *	<input type="text" value="24"/> hour(s)
UPnP Settings	<input type="radio"/> Enable <input checked="" type="radio"/> Disable

Note: You may need to reconnect to the wireless network after applying this change.

VPN Passthrough

VPN Passthrough	<input checked="" type="radio"/> Enable <input type="radio"/> Disable
-----------------	---

IP Address: The IP address for this device, as seen from the local network. This is set to a default value.

Subnet Mask: The default value 255.255.255.0 is standard for small (class "C") networks.

MAC Address: The MAC Address is a network identifier. This read-only field displays the MAC Address for the Wi-Fi interface on this device.

DHCP Server: This option is set to Enable by default. The DHCP server allocates an IP address to each Connected Device.

DHCP IP Pool: This is the IP address range used by the DHCP server. This indicates the range of IP addresses which may be allocated to connected devices.

DHCP Lease Time: This specifies the time period (in hours) for how long each device is assigned an internal IP address.

UPnP Settings: Universal Plug and Play (UPnP) is a set of networking protocols that permits networked devices to discover each other's presence on the network. The default value for this setting is Disable.

VPN Passthrough: This feature allows VPN client software on connected devices to connect through this device to remote VPN servers. Normally, this option should be set to Enabled.

MAC-IP Bind

MAC-IP Bind Switch Enable Disable

MAC Address * (e.g., 00:1E:90:FF:FF:FF)

IP Address * (e.g., 192.168.1.101)

Current Bind List

No.	MAC Address	IP Address
None		

MAC-IP Bind Switch: Select "Enable" to bind IP Address and MAC Address on your device.

MAC Address: The MAC Address is a network identifier. This read-only field displays the MAC Address for the Wi-Fi interface on this device.

IP Address: The IP address for this device, as seen from the local network. This is set to a default value.

Current Bind List: Lists any MAC-IP Bind you have bound.

Time/Date

Current Local Time: Displays the current date and time on the device.

Time Set Mode: Select from Manual Set Time or SNTP Auto Synchronization to determine how the AT&T Home Base determines local time.

Manual Set Time - Selecting this option will allow you to manually set the Month, Day, Year, Hour, Minute, and AM/PM parameters for your local time. Click "Apply" for changes to take effect.

SNTP Auto Synchronization - SNTP, or Simple Network Time Protocol, is used to allow synchronization of the date and time between your device and the system time on the network. You can pick up to three SNTP Servers you want your device to synchronize with, including specifying a server not listed by selecting "Other" from the dropdown and typing in the server address. You can also set the Time Zone and Daylight Saving Time status.

Call Blocking

You can input call blocking number and description, then click the 'Apply' button, and you will not receive phone calls from people on the call block list.

View Call Log Page: This is a link to **Call Log**, where you can view call log list.

Call Log list: Up to 30 phone number can be blocked in the list.

Backup/Restore

This screen provides the ability to export all your settings on this device. And also can import these settings to restore pre-settings by "Import Settings".

Export Settings: You can export configuration from device by clicking "Export".

Import Settings: You can select an exported file import to device. Select a file and click "Import".

Specifications

Dimensions (L×W×H)mm	160 (W) × 160(D) × 33 (H)
Weight	437.0g (including back-up battery)
Back-up Battery	3,000 mAh
Talk time	TBD
Standby time	TBD

Note: The value of the talk time or standby time varies with the actual environment.

Safety Instructions

- Some electronic devices may be susceptible to electromagnetic interference. Locate the router away from TV set, radio and other electronic equipment to avoid electromagnetic interference.
- The router may interfere with medical devices like hearing aids and pacemakers. Consult a physician or the manufacturer of the medical device before using the router.
- Please keep yourself at least eight (8) inches away from router.
- Do not use your router in dangerous environments such as oil terminals or chemical factories where there are explosive gases or explosive products being processed.
- Please use original accessories or accessories that are authorized by ZTE. Unauthorized accessories may affect the router performance, damage the router or cause danger to you.
- Do not attempt to dismantle the router. There are no user serviceable parts.
- Do not allow the router or accessories to come into contact with liquid or moisture at any time. Do not immerse the router in any liquid.
- Do not place objects on top of the router. This may lead to overheating of the device.

- The device must be placed in ventilated environment for use.
- Do not expose the router to direct sunlight or store it in hot areas. High temperature can shorten the life of electronic devices.
- Do not allow children to play with the router or charger.
- Keep the length of the cable between the router and the phone less than 11 yards.
- The router is for indoor use only. Do not use the router outside. Do not connect telephone extensions which run outside of the building. These can result in lightning damage to your unit.

FCC Regulations

This device complies with part 15 of the FCC Rules. Operation is subject to the following two conditions: (1) This device may not cause harmful interference, and (2) this device must accept any interference received, including interference that may cause undesired operation.

This device has been tested and found to comply with the limits for a Class B digital device, pursuant to Part 15 of the FCC Rules. These limits are designed to provide reasonable protection against harmful interference in a residential installation. This equipment generates, uses and can radiate radio frequency energy and, if not installed and used in accordance with the instructions, may cause harmful interference to radio communications. However, there is no guarantee that interference will not occur in a particular installation. If this equipment does cause harmful interference to radio or television reception, which can be determined by turning the equipment off and on, the user is encouraged to try to correct the interference by one or more of the following measures:

- Reorient or relocate the receiving antenna.
- Increase the separation between the equipment and receiver.
- Connect the equipment into an outlet on a circuit different from that to which the receiver is connected.
- Consult the dealer or an experienced radio/TV technician for help.

Changes or modifications not expressly approved by the party responsible for compliance could void the user's authority to operate the equipment.

RF Exposure Information

This device meets the government's requirements for exposure to radio waves.

This device is designed and manufactured not to exceed the emission limits for exposure to radio frequency (RF) energy set by the Federal Communications Commission of the U.S. Government.

This device complies with FCC radiation exposure limits set forth for an uncontrolled environment. In order to avoid the possibility of exceeding the FCC radio frequency exposure limits, human proximity to the antenna shall not be less than 20cm (8 inches) during normal operation.

CTIA

- Do not disassemble or open, crush, bend or deform, puncture or shred.
- Do not modify or remanufacture, attempt to insert foreign objects into the battery, immerse or expose to water or other liquids, expose to fire, explosion or other hazard.
- Only use the battery for the system for which it is specified.
- Only use the battery with a charging system that has been qualified with the system per CTIA Certification Requirements for Battery System Compliance to IEEE 1725. Use of an unqualified battery or charger may present a risk of fire, explosion, leakage, or other hazard.
- Do not short circuit a battery or allow metallic conductive objects to contact battery terminals.
- Replace the battery only with another battery that has been qualified with the system per this standard, IEEE-Std-1725. Use of an unqualified battery may present a risk of fire, explosion, leakage, or other hazard.
- Promptly dispose of used batteries in accordance with local regulations.
- Battery usage by children should be supervised.
- Avoid dropping the phone or battery. If the phone or battery is dropped, especially on a hard surface, and the user suspects damage, take it to a service center for inspection.
- Improper battery use may result in a fire, explosion, or other hazard.

For those host devices that utilize a USB port as a charging source, the host device's user manual shall include a statement that the phone shall only be connected to CTIA certified adapters, products that bear the USB-IF logo or products that have completed the USB-IF compliance program.

Warranty

ZTE offers you a limited warranty that the enclosed subscriber unit and its enclosed accessories will be free from defects in material and workmanship for a period that expires one (1) year from the date of sale of the Product to you, provided that you are the original end-user purchaser of the Product and provided that your purchase was made from a supplier authorized by the Seller. Transfer or resale of a Product will automatically terminate warranty coverage with respect to that Product. This limited warranty is not transferable to any third party, including but not limited to any subsequent purchaser or owner of the Product. This limited warranty is applicable only to end users in the United States.

This product or phone is warranted for 12 months from date of purchase.

For warranty service information, please call ZTE service number (877) 817-1759 (toll-free). The manufacturer's website, <http://www.zteusa.com>, is also available for assistance.

This warranty only applies if the product has been used in accordance with the manufacturer's instructions under normal use and with reasonable care.

What this warranty does not cover:

- a) Defects or damages resulting from the misuse of this product.

- b) Defects or damages from abnormal use, abnormal conditions, improper storage, exposure to moisture, dampness or corrosive environments, unauthorized modifications, unauthorized repair, neglect, rough handling, abuse, accident, alteration, improper installation, incorrect voltage application, food or liquid spoilage, acts of God.
- c) Normal wear and tear.
- d) If the Product has been opened, modified or repaired by anyone other than a warranty service center or if it is repaired using unauthorized spare parts.
- e) If the serial number or mobile accessory date code has been removed, erased, defaced, altered, or are illegible in any way subject to sole judgment of ZTE.

LIMITED WARRANTY

TO THE EXTENT PERMITTED BY APPLICABLE LAW, THIS LIMITED WARRANTY IS YOUR SOLE AND EXCLUSIVE REMEDY AGAINST ZTE AND ZTE'S SOLE AND EXCLUSIVE LIABILITY IN RESPECT OF DEFECTS IN PRODUCT. HOWEVER, THIS LIMITED WARRANTY SHALL NOT EXCLUDE NOR LIMIT ANY OF YOUR LEGAL (STATUTORY) RIGHTS UNDER THE APPLICABLE NATIONAL LAWS.

TO THE EXTENT PERMITTED BY APPLICABLE LAW ZTE DOES NOT ASSUME ANY LIABILITY FOR LOSS OF OR DAMAGE TO OR CORRUPTION OF DATA, FOR ANY LOSS OF PROFIT, LOSS OF USE OF PRODUCTS OR FUNCTIONALITY, LOSS OF BUSINESS, LOSS OF REVENUES OR LOSS OF ANTICIPATED PROFIT, INCREASED COSTS OR EXPENSES OR FOR ANY INDIRECT, OR SPECIAL OR CONSEQUENTIAL LOSS OR DAMAGE. TO THE EXTENT PERMITTED BY APPLICABLE LAW, ZTE'S LIABILITY SHALL BE LIMITED TO THE PURCHASE VALUE OF THE PRODUCT. THE ABOVE LIMITATIONS SHALL NOT APPLY TO DEATH OR PERSONAL INJURY CAUSED BY DEFECT OF PRODUCT IN MATERIAL, DESIGN, AND WORKMANSHIP.

How to Get Warranty Service

To obtain warranty service, please call (877) 817-1759. Please have the following information available when you send the device in for repair:

- A valid Proof of Purchase
- Return address
- Daytime phone number or fax number
- Model #
- IMEI # (Look for the 15-digit IMEI # behind the back-up battery of the device.)
- Complete description of the problem
- Transportation prepaid

Other Warranty Programs

You may have other warranty programs with your purchase, such as warranty exchange. If so, please refer to equipment package or the original point of sale.

AT&T Home Base™ ("Home Base") is a mobile device. It may be used in the U.S. with home phone equipment, computers, and other Wi-Fi compatible devices. For emergency calls, provide your location address to the 911

operator. Home Base has a back-up battery in the event of a power outage. However, a cordless phone connected to the Home Base will not operate (including 911) during a power outage. To use back-up battery power, you must plug a corded phone into the Home Base. Corded or other landline phone equipment and Internet capable devices (e.g. PCs, tablets) not provided with service. Provides voice and wireless data service. Not compatible with wireless messaging services, security systems, fax services, medical alert and monitoring systems, credit card machines, IP/PBX Phone systems, or dial-up Internet service. May not be compatible with DVR/Satellite systems; please check with your provider. DSL customers should contact their provider before transferring a phone number to ensure uninterrupted DSL Internet service. Home Base sold for use on the AT&T wireless network and cannot be activated on other carriers' wireless networks.

Service provided by AT&T Mobility. © 2017 AT&T Intellectual Property. All rights reserved. AT&T, the AT&T logo and all other AT&T marks contained herein are trademarks of AT&T Intellectual Property and/or AT&T affiliated companies. All other marks contained herein are the property of their respective owners.

Portions Copyright © 2017 ZTE CORPORATION.

All rights reserved.

No part of this publication may be excerpted, reproduced, translated or utilized in any form or by any means, electronic or mechanical, including photocopying and microfilm, without the prior written permission of ZTE Corporation.

The manual is published by ZTE Corporation. We reserve the right to make modifications on print errors or update specifications without prior notice.

Version No. : R1.0

Edition Time: 2017.7

Manual No. : XXXXXX