

## 4.5 Cabinet Installation

### 4.5.1 Installation Mode Instruction

According to different installation environments, there are three modes of R8860E GU198 installation:

- Pole-mount installation
- Wall-mount installation
- Gantry-mount installation
- Simplified-cabinet integrative Installation

### 4.5.2 Installation Methods and Accessories

There are two installation methods for R8860E GU198, as below:

- Pole mounted installation (Pole Mounting Kit): It is suggested that the diameter of installation pole should be 60 mm ~ 120 mm.
- Pole mounted installation (Universal Sheet-Metal Kit): It is suggested that the diameter of installation pole should be 60 mm ~ 114 mm.
- Wall mounted installation.



**Note:**

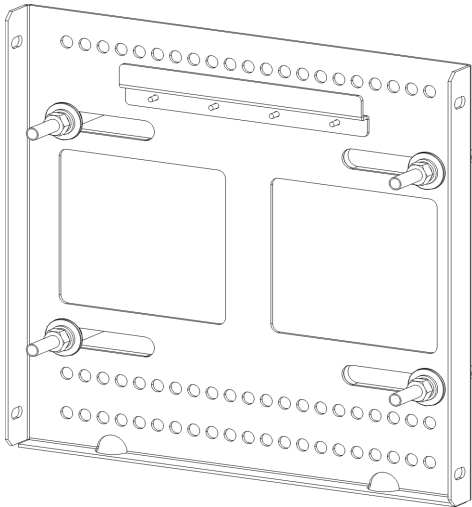
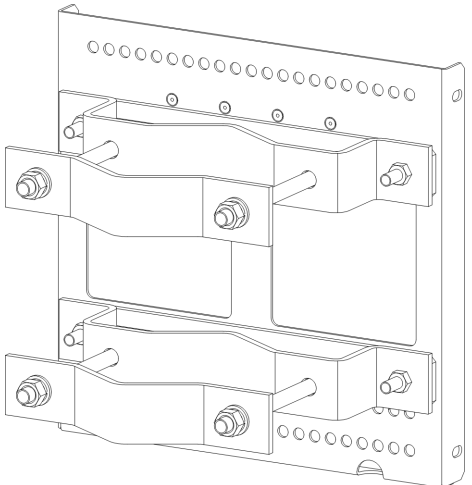
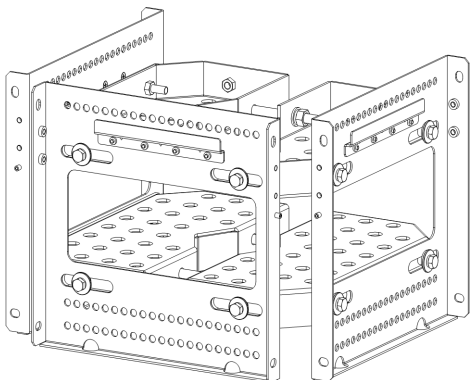
The universal sheet-metal kit also support channel iron and angle iron. The supported channel width is 50mm–100mm. The supported angle iron width is 63mm-80mm. (The installation method is similar to the pole installation.)

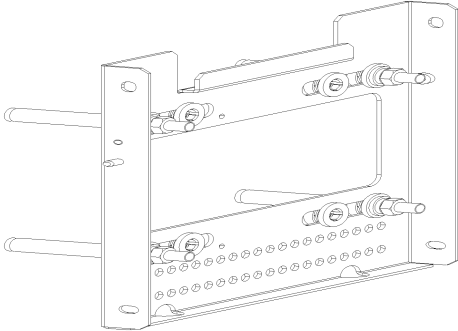
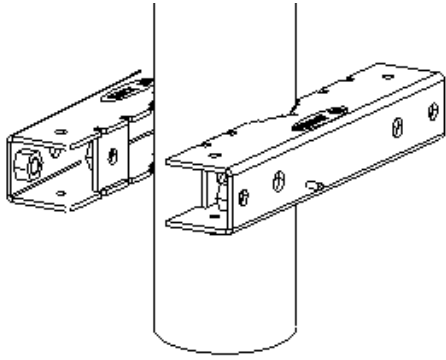
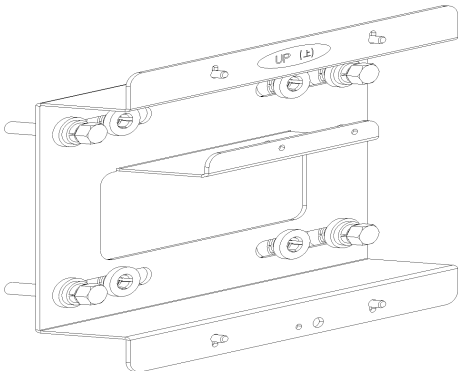
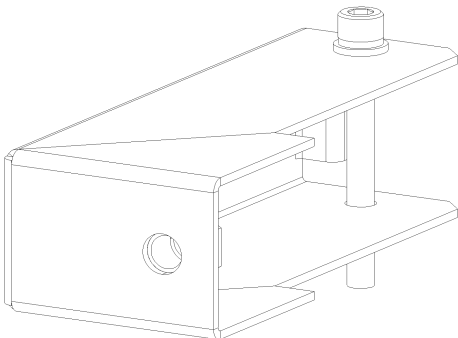
---

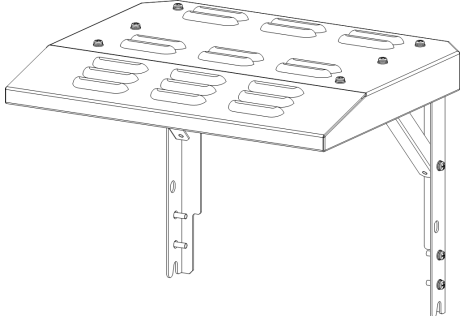
#### 4.5.2.1 Installation Accessories

The installation accessories of R8860E GU198 and their functions are shown in [Table 4-3](#).

**Table 4-3 INSTALLATION ACCESSORIES OF R8860E GU198 AND THEIR FUNCTIONS**

Name	Shape	Function
<p>Wall mounted installation assembly</p>		<p>Used by wall mounted and pole mounted installation (clamp assembly for pole mounted installation)</p>
<p>Clamp assembly for pole mounted installation</p>		<p>For the pole with 1 or 2 R8860E GU198 pole mounted installation</p>
<p>Mounting bracket assembly for pole mounted installation</p>		<p>For the pole with 3 R8860E GU198 pole mounted installation</p>

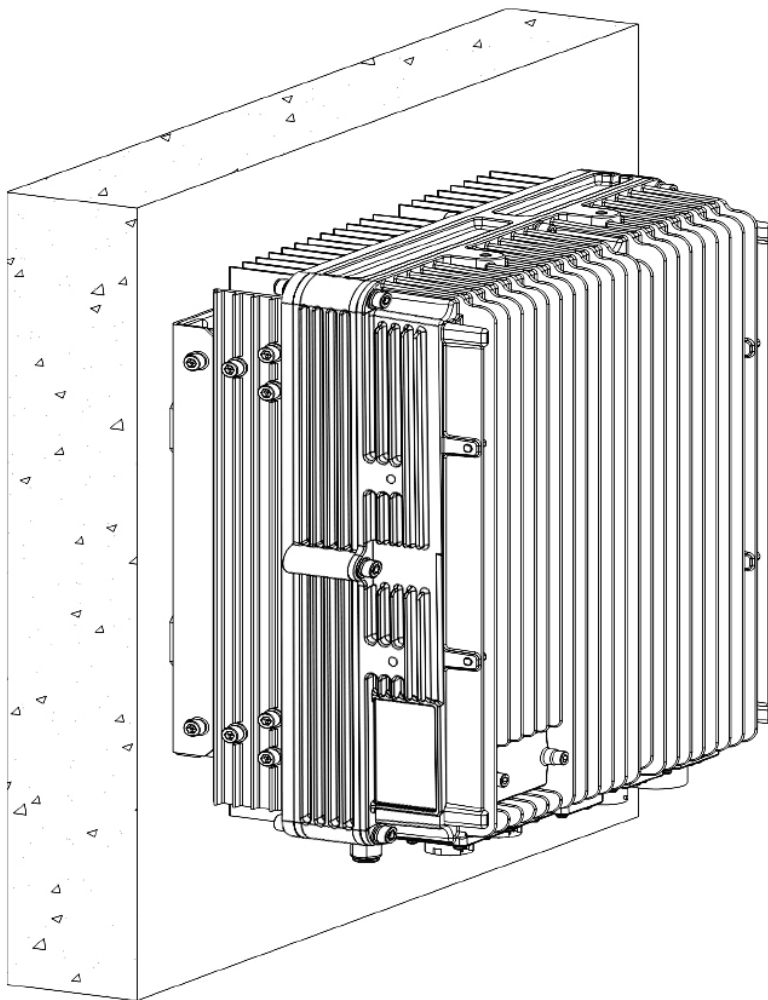
Name	Shape	Function
Mounting Base		Used by pole mounted installation of R8860E GU198
Mounting Piece		Used by fixing on the pole
Lightning pretector piece		Used by pole mounted installation of Lightning pretector box
Expansion piece		For the pole with the third R8860E GU198 pole mounted installation

Name	Shape	Function
Protection shade		To shield R8860E GU198 from direct sun light

### 4.5.2.2 Wall Mounted Installation

Fix the assembly for wall mounted installation on the wall, and then fix R8860E GU198 on the assembly with bolts, as shown in [Figure 4-7](#).

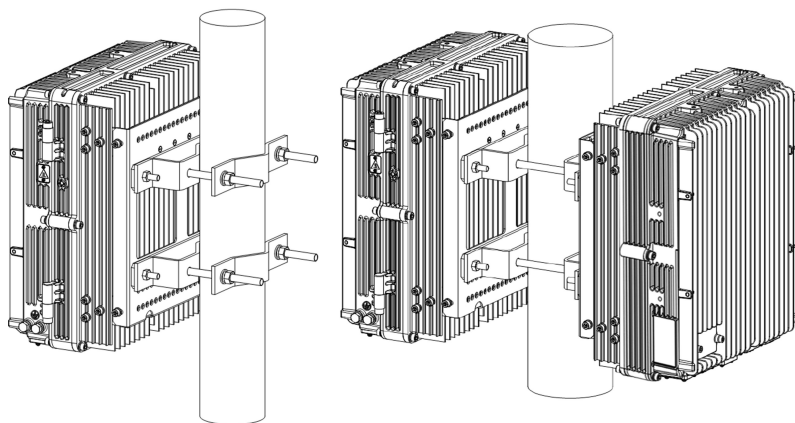
**Figure 4-7 WALL MOUNTED INSTALLATION FOR R8860E GU198**



### 4.5.2.3 Pole Mounted Installation (Pole Mounting Kit)

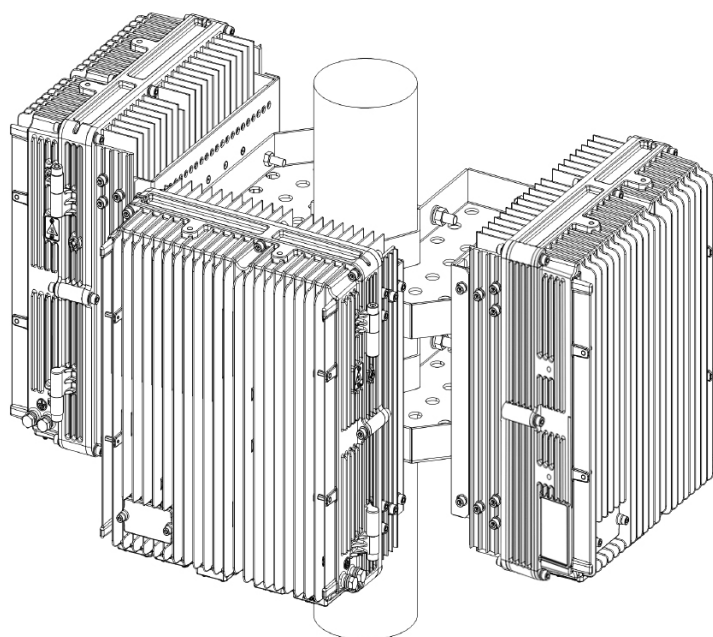
If there are only 1 or 2 R8860E GU198s, use the clamp assembly to fix it/them on the pole, as shown in [Figure 4-8](#).

**Figure 4-8 POLE MOUNTED INSTALLATION FOR 1 OR 2 R8860E GU198s**



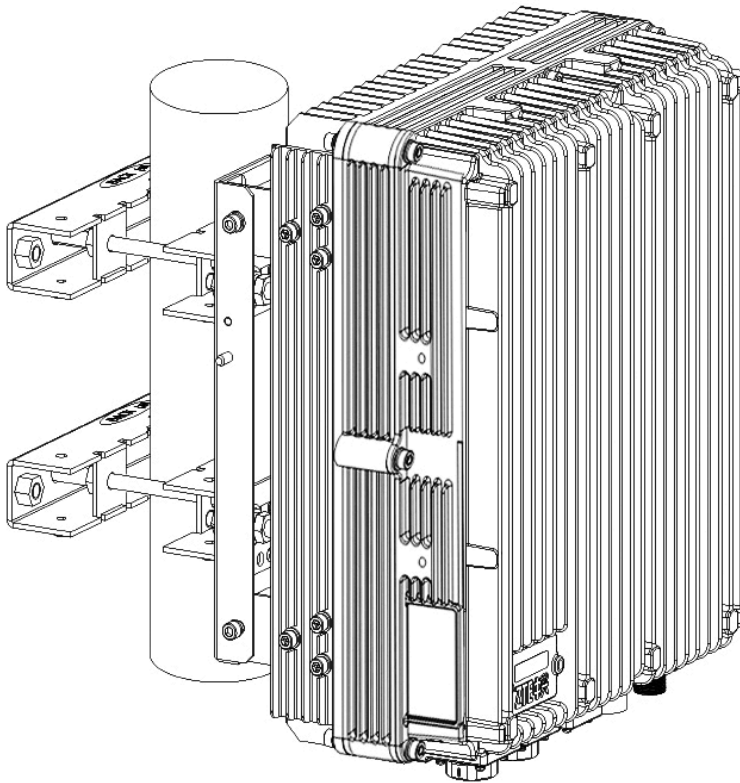
If there are 3 R8860E GU198s, use the mounting bracket assembly to fix them on the pole, as shown in [Figure 4-9](#).

**Figure 4-9 POLE MOUNTED INSTALLATION FOR 3 R8860E GU198s**

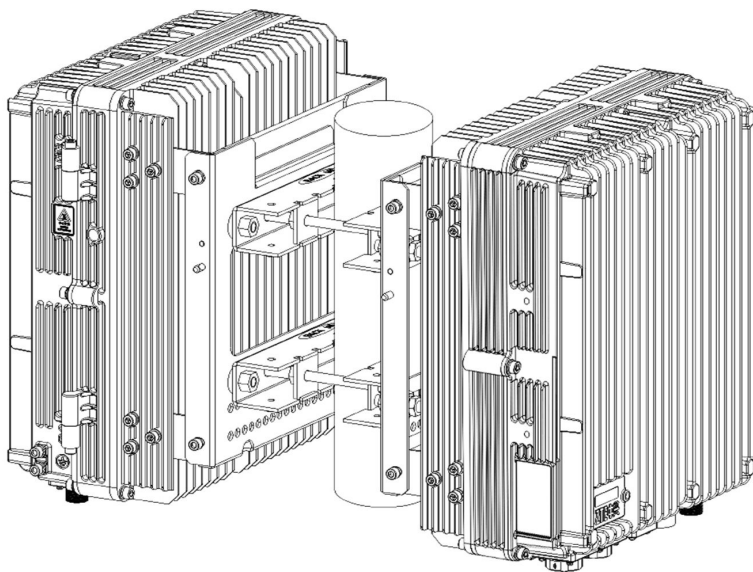


### 4.5.2.4 Pole Mounting (Universal Sheet-Metal Kit)

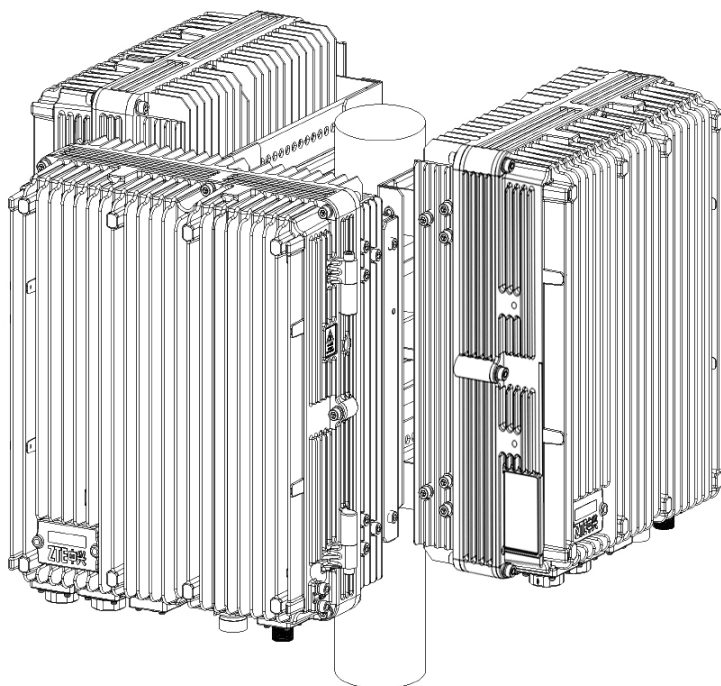
In the single R8860E GU198 solution the unit is fixed on the pole by an universal mounting kit, as shown in [Figure 4-10](#).

**Figure 4-10 The Single R8860E GU198 Mounting Solution**

In the double R8860E GU198 solution the unit is fixed on the pole by an universal mounting kit, as shown in [Figure 4-11](#).

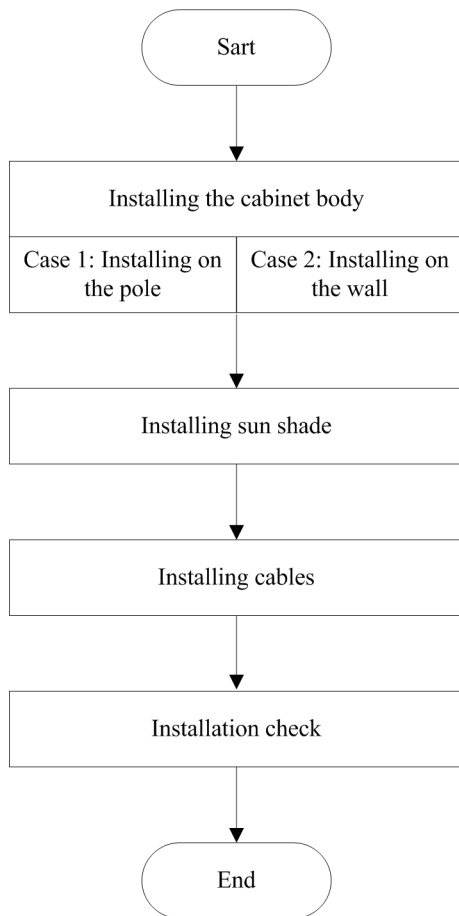
**Figure 4-11 The Double R8860E GU198 Mounting Solution**

In the triple R8860E GU198 solution the unit is fixed on the pole by an universal mounting kit, as shown in [Figure 4-12](#).

**Figure 4-12 The Triple R8860E GU198 Mounting Solution**

### 4.5.3 R8860E GU198 Installation

The installation of R8860E GU198 includes two parts, that is, main part installation and cable installation. The installation flow is shown in [Figure 4-13](#).

**Figure 4-13 R8860E GU198 INSTALLATION FLOW**

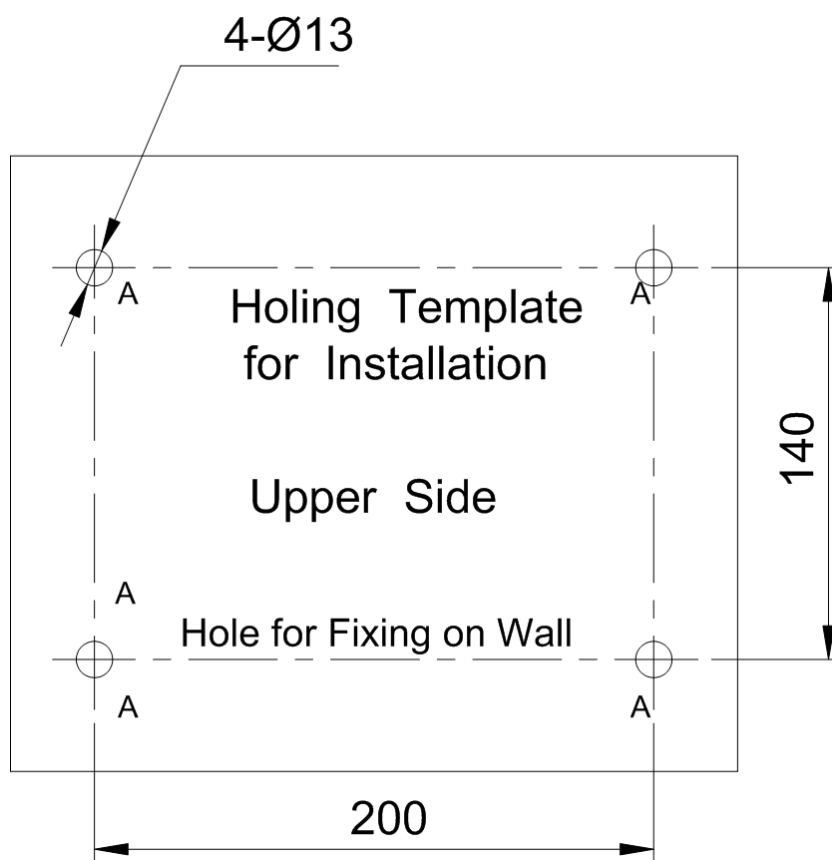
### 4.5.3.1 Wall Mounted Installation for R8860E GU198

#### Steps

1. Drill holes on the wall with holing template according to the R8860E GU198 installation position specified in the engineering design documents, and install the expansion bolts. The depth of the hole should be about 60 mm. The holing template is shown in [Figure 4-14](#).

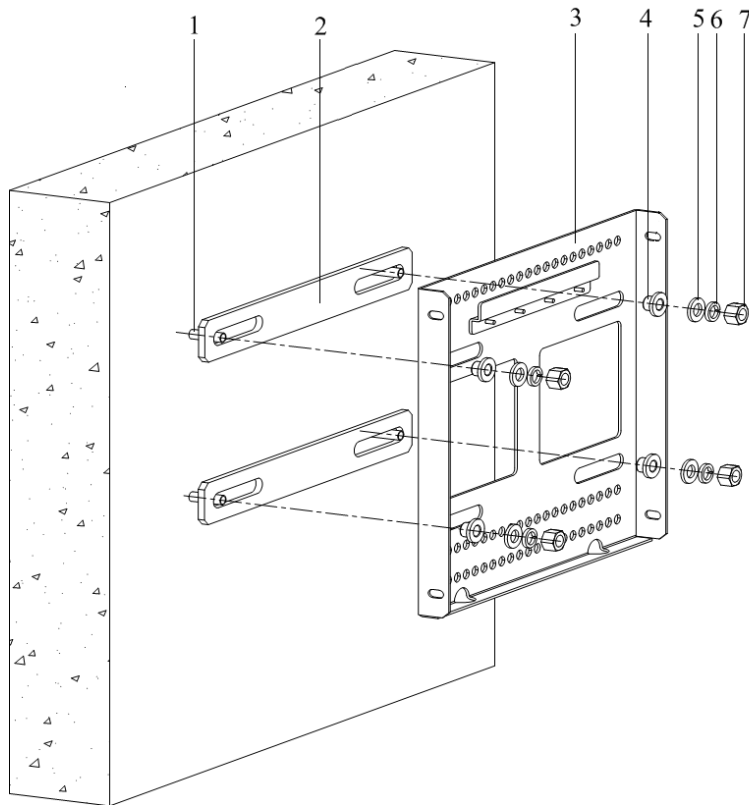


Figure 4-14 HOLING TEMPLATE



2. Assemble the wall mounted installation assembly, as shown in [Figure 4-15](#). Fix the assembly on the wall with bolts.

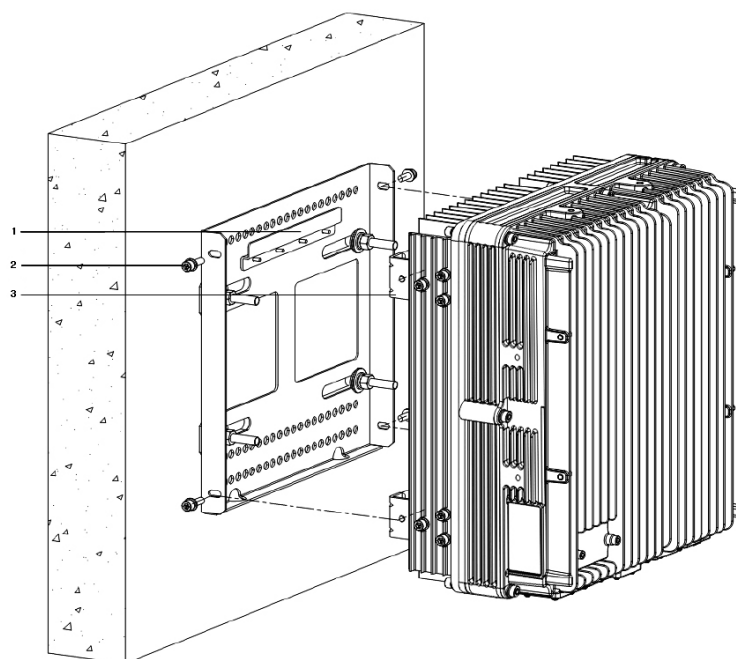
**Figure 4-15 ASSEMBLING WALL-MOUNTED INSTALLATION ASSEMBLY**



- |                        |                      |        |
|------------------------|----------------------|--------|
| 1. Expansion bolt      | 4. Insulation flange | 7. Nut |
| 2. Insulation plate    | 5. Flat washer       |        |
| 3. Wall-mounting plate | 6. Spring washer     |        |

3. Hang the R8860E GU198 cabinet on the wall mounted installation assembly (align it with the clamps), and fix the cabinet to the assembly with 2 M6 bolts, as shown in [Figure 4-16](#).

Figure 4-16 FIXING THE CABINET



1. Wall-mounting installation components clamp
2. Screw
3. Fixation board

– End of Steps –

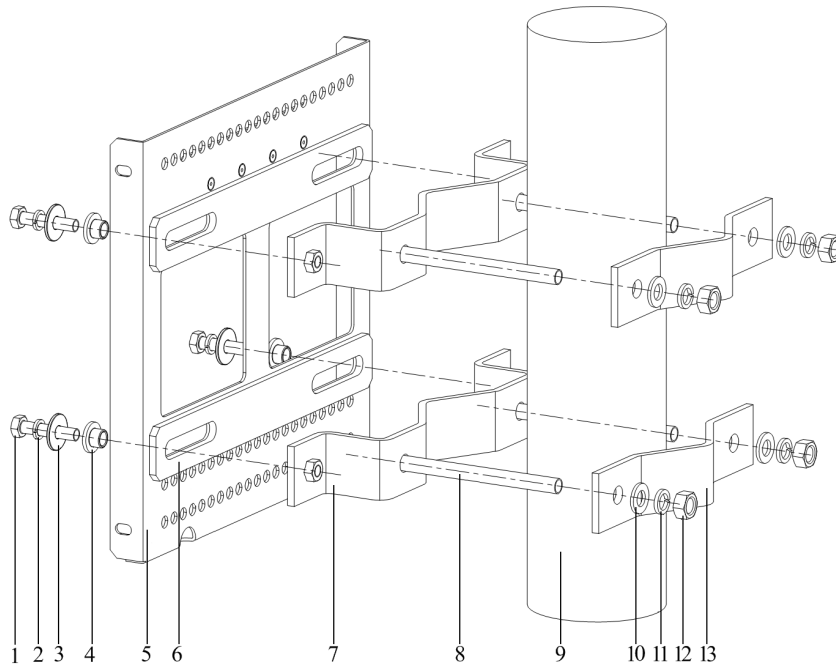
### 4.5.3.2 Pole Mounted Installation for R8860 Pole Mounting Kit

#### 4.5.3.2.1 Installing 1 R8860E GU198

##### Steps

1. Install 2 sets of clamp assemblies on the pole, and fasten them just a little. Adjust the distance between the pole clamp assemblies according to the screw holes and then fasten M8 bolts. Finally, fasten the screws on the pole clamp assemblies, as shown in [Figure 4-17](#).

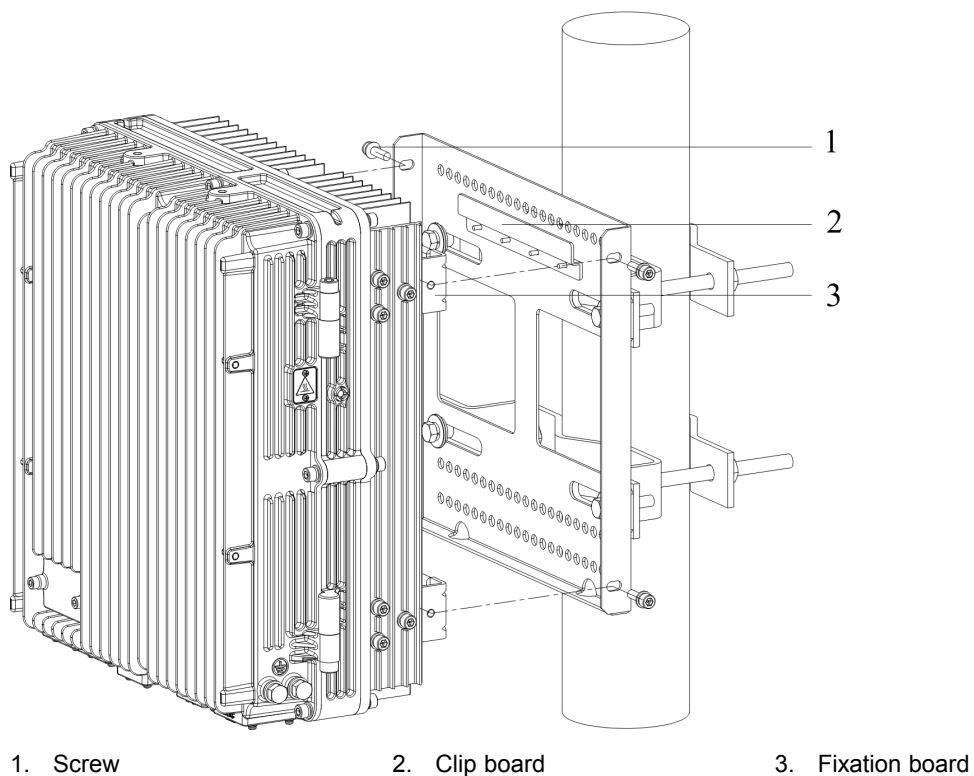
**Figure 4-17 INSTALLING CLAMP ASSEMBLY**



- |  |                     |              |
|--|---------------------|--------------|
| 1. M8 nut                                | 6. Insulation board | 12. Nut Hoop |
| 2. Spring washer                         | 7. Hoop             | 13. Hoop     |
| 3. Flat washer                           | 8. Bolt             |              |
| 4. Insulation flange                     | 9. Pole             |              |
| 5. Wall-mounting installation assemblies | 10. Plain washer    |              |
|  | 11. Spring washer   |              |

2. Hang the R8860E GU198 cabinet on the wall mounted installation assembly (align it with the clamps), and fix the cabinet to the assembly with 2 M6 bolts, as shown in [Figure 4-18](#).

Figure 4-18 FIXING THE CABINET

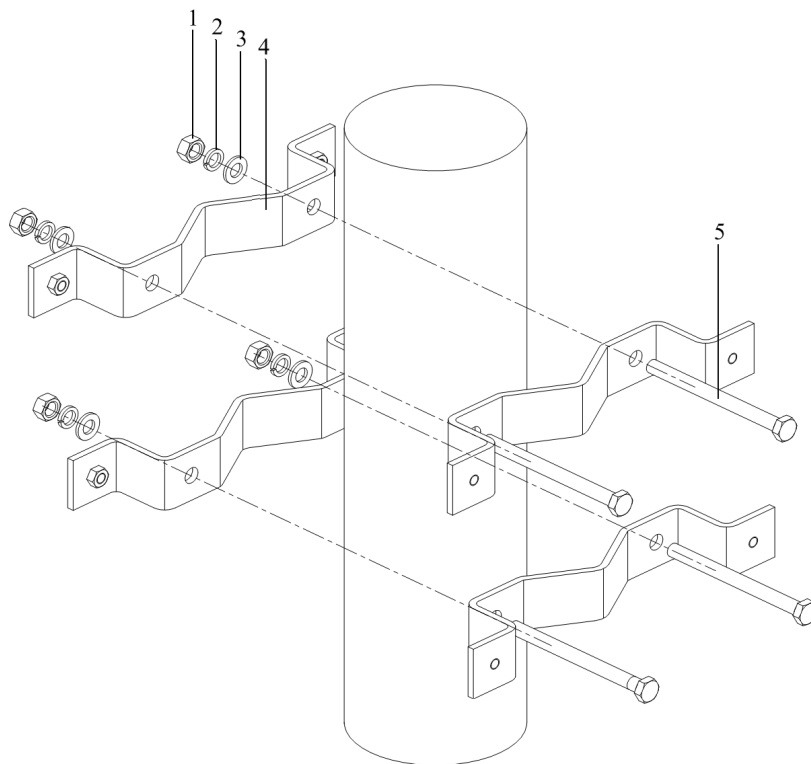


– End of Steps –

#### 4.5.3.2.2 Installing 2 R8860E GU198s

##### Steps

1. Install 4 sets of clamp assemblies on the pole, and fasten them just a little, as shown in [Figure 4-19](#).

**Figure 4-19 INSTALLING CLAMP ASSEMBLY**

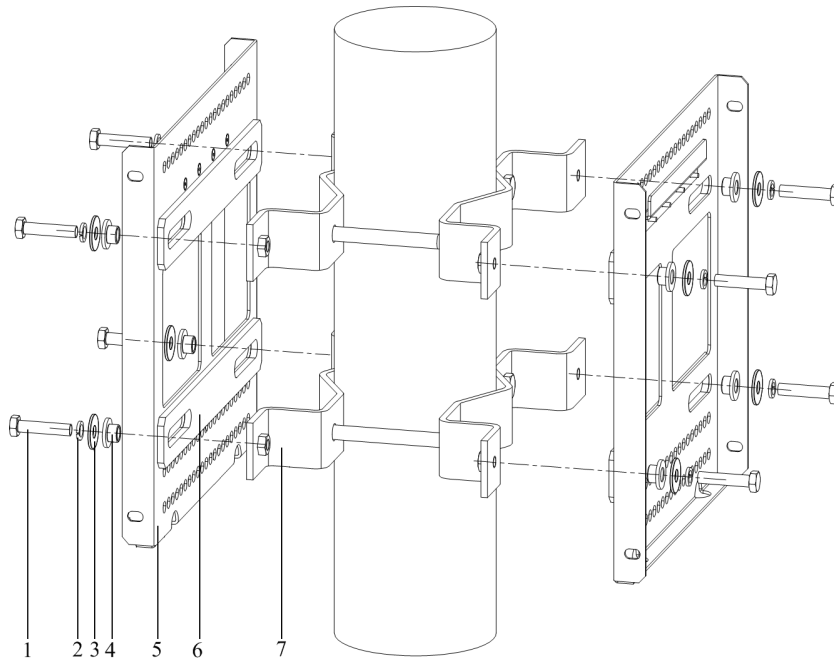
- |                  |                 |         |
|------------------|-----------------|---------|
| 1. Nut           | 3. Plain washer | 5. Bolt |
| 2. Spring washer | 4. Hoop         |         |

**Note:**

When installing 2 R8860E GU198s, decide the length of clamp assembly bolts according to the result of engineering survey. If the pole diameter is in the range 60 mm ~ 90 mm, use bolts with the length 80 mm. If the pole diameter is in the range 90 mm ~ 120 mm, use bolts with the length 130 mm.

- Assemble 2 sets of wall mounted installation assemblies and fasten the M8 bolts, as shown in [Figure 4-20](#). Fasten the bolts of the clamp assemblies.

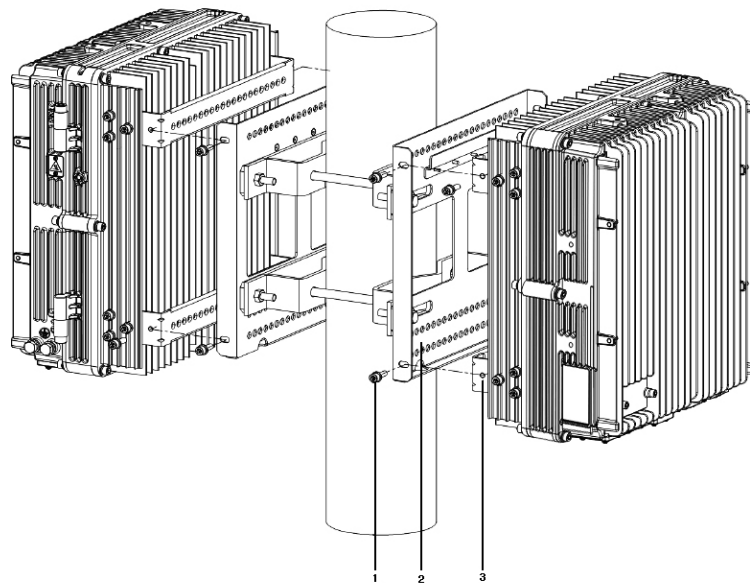
**Figure 4-20 ASSEMBLING WALL-MOUNTED INSTALLATION ASSEMBLY**



- |                  |  |                      |
|------------------|--|----------------------|
| 1. Bolt          | 4. Insulation flange                     | 6. Insulation washer |
| 2. Spring washer | 5. Wall-mounting installation assemblies | 7. Hoop              |
| 3. Plain washer  |  |                      |

3. Hang the R8860E GU198 cabinet on the wall mounted installation assembly (align it with the clamps), and fix the cabinet to the assembly with 2 M6 bolts, as shown in [Figure 4-21](#).

**Figure 4-21 FIXING THE CABINET**



- |          |  |
|----------|--|
| 1. Screw | 2. Wall-mounting installation assemblies |
|----------|--|

3. Fixation board

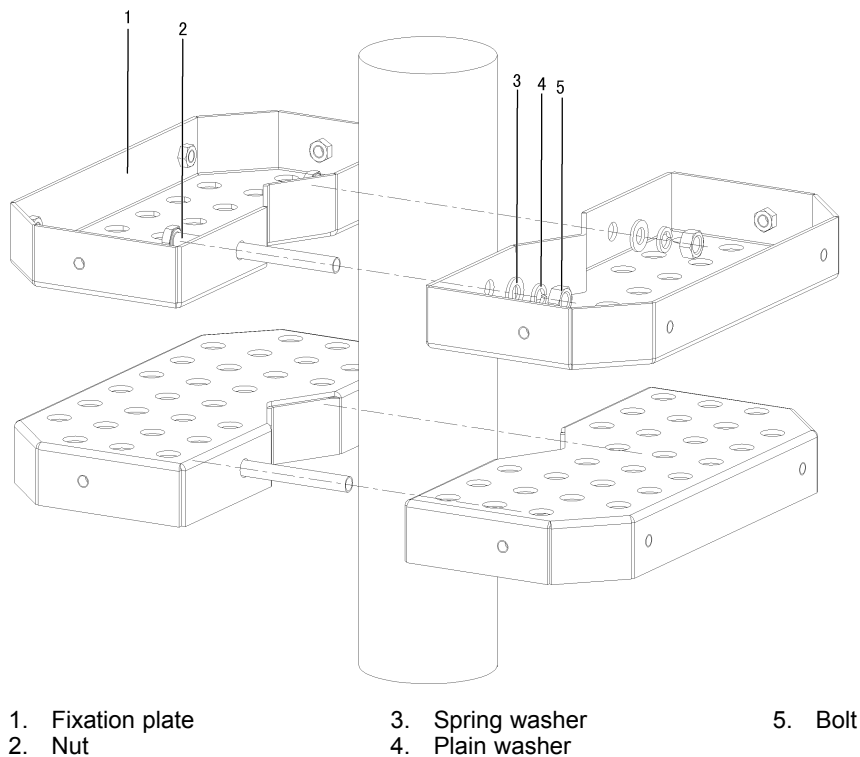
– End of Steps –

#### 4.5.3.2.3 Installing 3 R8860E GU198s

##### Steps

1. Install 4 sets of mounting bracket assemblies on the pole, back to back, and fasten them just a little, as shown in [Figure 4-22](#).

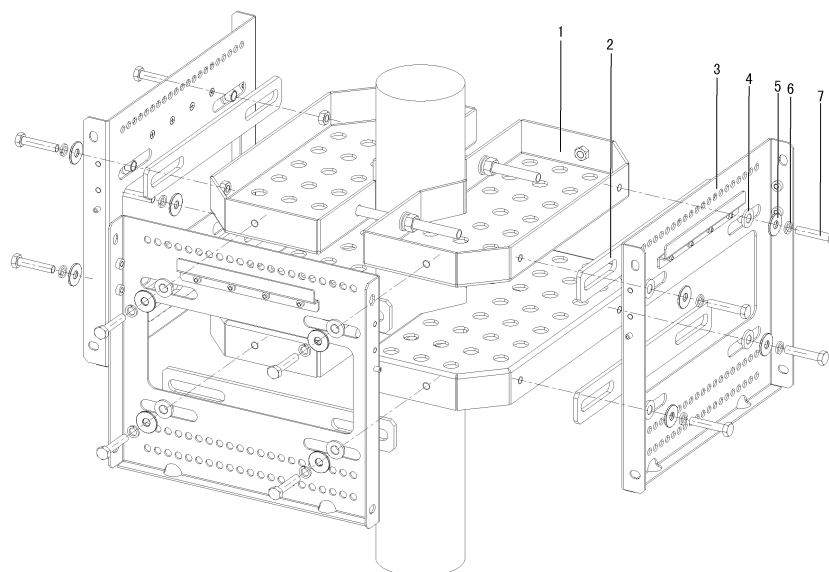
**Figure 4-22 INSTALLING MOUNTING BRACKET ASSEMBLY**



2. Assemble 3 sets of wall mounted installation assemblies and fasten the M8 bolts, as shown in [Figure 4-23](#). Fasten the bolts of the clamp assemblies.



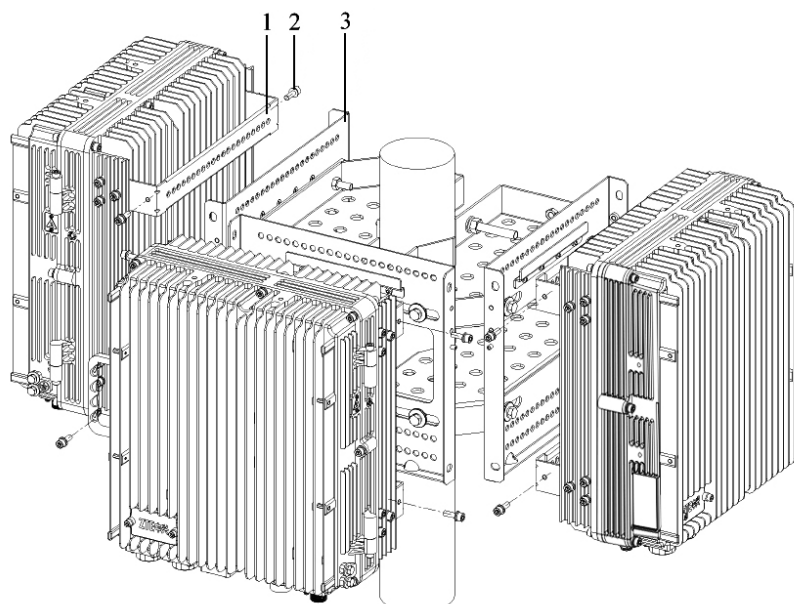
**Figure 4-23 ASSEMBLING WALL-MOUNTED INSTALLATION ASSEMBLY**



- |                           |  |                  |
|---------------------------|--|------------------|
| 1. Fixation plate         | 3. Wall-mounting installation assemblies | 5. Plain washer  |
| 2. Large insulation plate | 4. Insulation flange                     | 6. Spring washer |
|                           |  | 7. Bolt          |

3. Hang the R8860E GU198 cabinet on the wall mounted installation assembly (align it with the clamps), and fix the cabinet to the assembly with 2 M6 bolts, as shown in Figure 4-24.

**Figure 4-24 FIXING THE CABINET**



- |          |  |                   |
|----------|--|-------------------|
| 1. Screw | 2. Wall-mounting installation assemblies | 3. Fixation board |
|----------|--|-------------------|

**Note:**

The empty side of mounting bracket can be beside the wall or used to install outdoor lightning protection box.

– End of Steps –

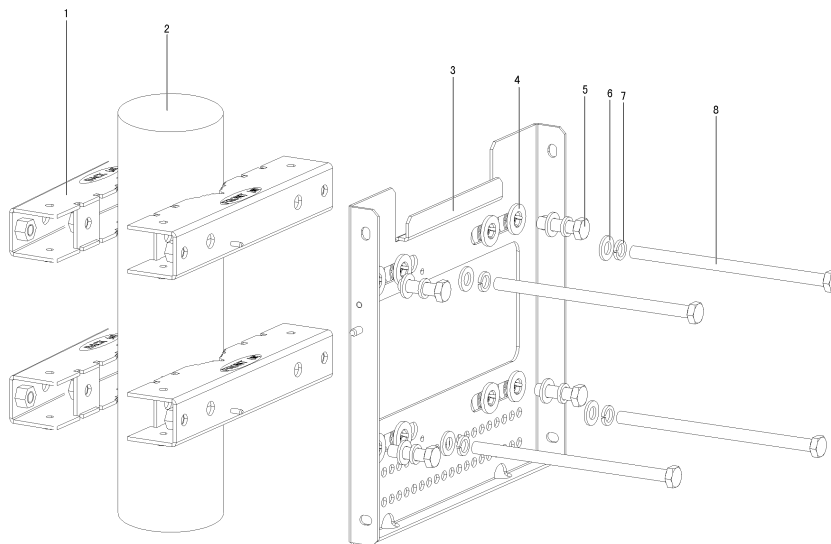
### 4.5.3.3 Pole Mounting (Universal Sheet-Metal Kit)

#### 4.5.3.3.1 Pole Mounting (Single Unit Solution)

##### Steps

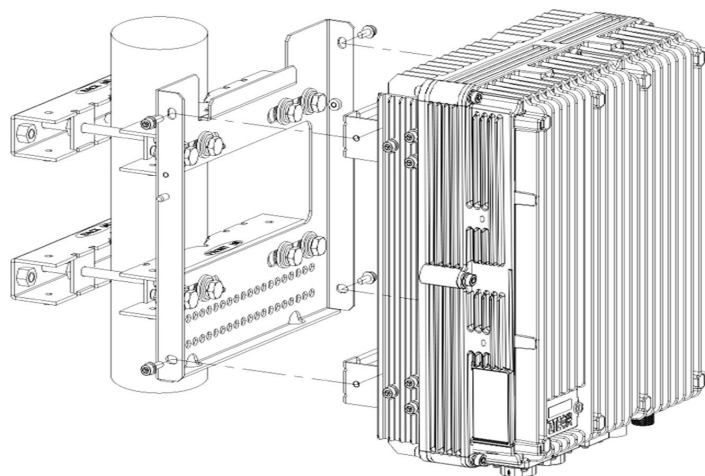
1. Fix two sets of front mounting pieces (keep the screen printing on the top) onto the mounting base by four M8×35 bolts, and insert four M10×180 long bolts to the mounting base and attach the mounting base to the pole, then attach two mounting pieces (keep the screen printing on the top) to the opposite position of the pole and connect them to the long bolt as shown in [Figure 4-25](#).

**Figure 4-25 Fixing the Mounting Piece**



- |  |                      |                      |
|--|----------------------|----------------------|
| 1. Mounting Piece (the screen printing on the top) | 3. Mounting Base     | 7. Lock Washer       |
| 2. Pole  | 4. Insulating Flange | 8. M10×180 Long Bolt |
|  | 5. M8×35 Bolt        |                      |
|  | 6. Flat Washer       |                      |

2. Attach the R8860E GU198 onto the hooks on the mounting base and fasten it with four M6×20 allen screws, as shown in [Figure 4-26](#).

**Figure 4-26 Mounting R8860E GU198**

**– End of Steps –**

#### 4.5.3.3.2 Pole Mounting (Double Unit Solution)

##### Steps

1. Fix two sets of front mounting pieces (keep the screen printing on the top) onto the mounting base by four M8×35 bolts. And Insert four M10×180 long bolts to the mounting base.
2. Fix two sets of rear mounting pieces (keep the screen printing on the top) onto another mounting base by four M8×35 bolts.
3. Attach the front/rear mounting pieces to the pole (keep the screen printing on the top). Fasten the M10×180 long bolts (note the bolts go through the insulating flange), as shown in [Figure 4-27](#) and [Figure 4-28](#).

Figure 4-27 Mounting base Double Unit Solution

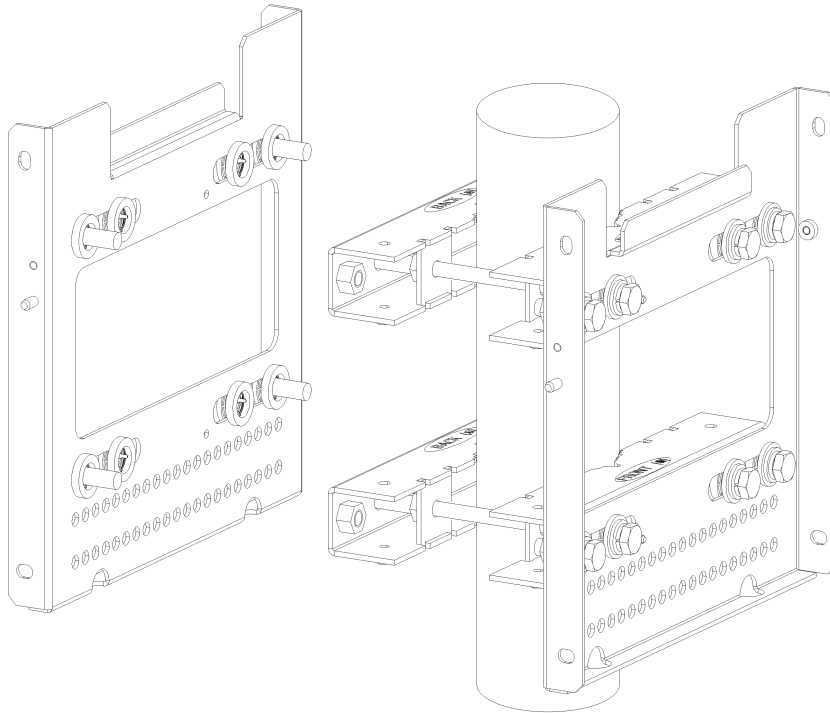
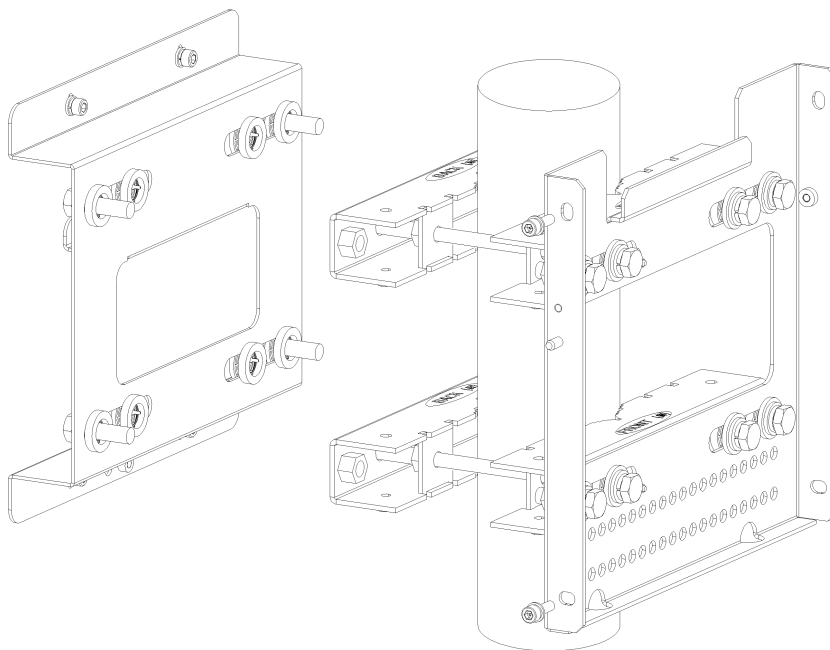


Figure 4-28 Mounting base Single Unit + Lightning Protector Box Solution



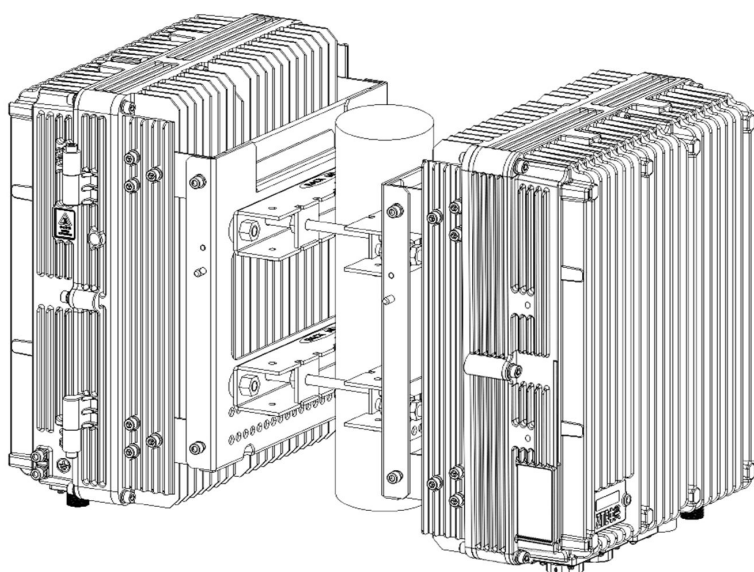
**Note:**

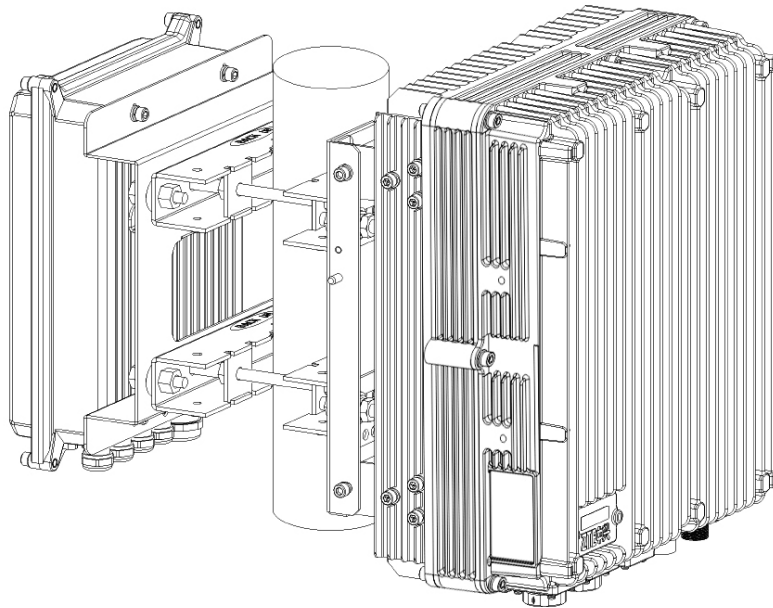
The fasteners are shown in the last section single unit solution.

The double unit mounting base solution supports two R8860E GU198 or one R8860E GU198 and a light arrestor unit.

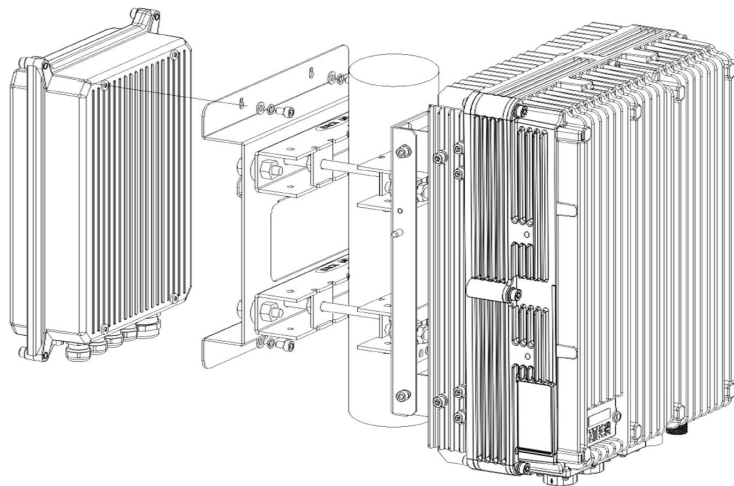
4. Fasten the M10×180 bolts and attach R8860E GU198 to the mounting base. Fasten the connection with the M6×20 Allen bolts, as shown in [Figure 4-29](#) and [Figure 4-30](#).

**Figure 4-29 Mounting Two R8860E GU198**



**Figure 4-30 Mounting one R8860E GU198 and One Lightning Protector Box****Note:**

The lightning protector box is fixed onto the lightning protector box mounting base with the bolts fastened, as shown in [Figure 4-31](#).

**Figure 4-31 Fixing the Lightning Protector Box**

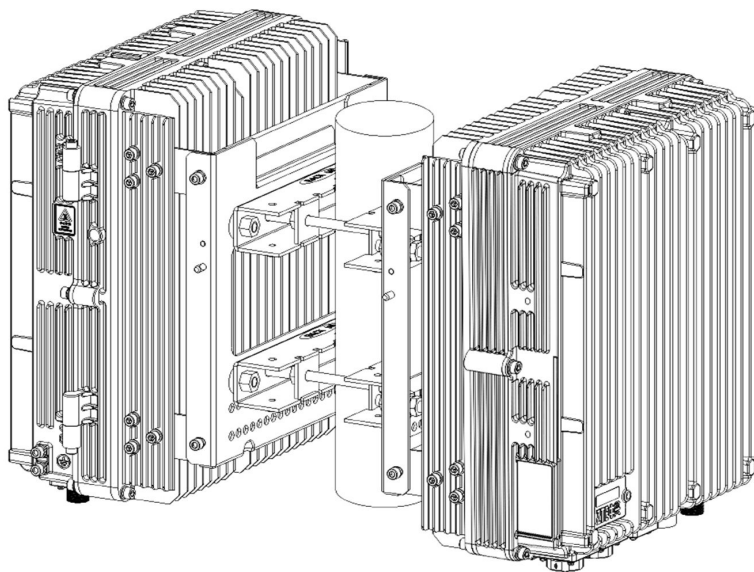
**– End of Steps –**

### 4.5.3.3.3 Pole Mounting (Triple Unit Solution)

#### Steps

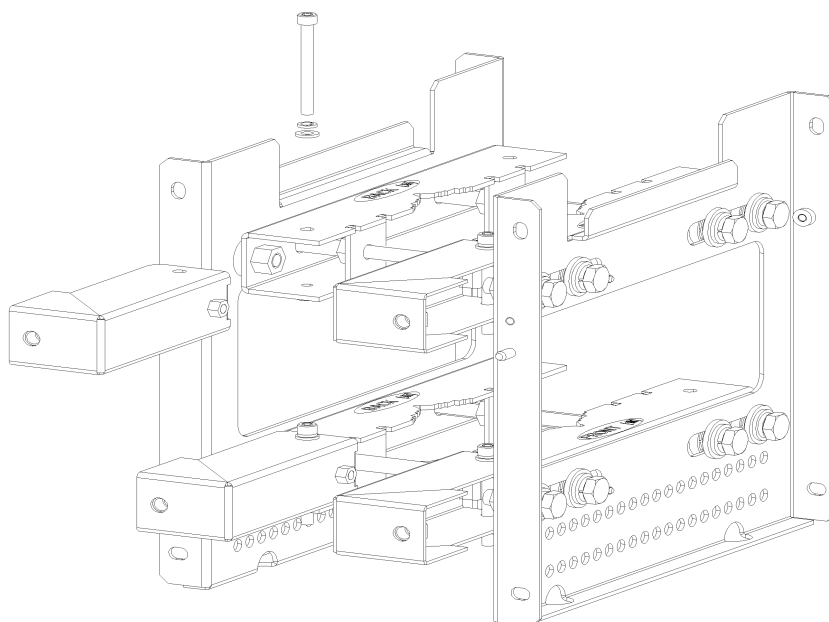
1. Secure two sets of mounting pieces and mounting bases on the pole and attach two R8860E GU198, as shown in Figure 4-32.

Figure 4-32 Mounting Two R8860E GU198



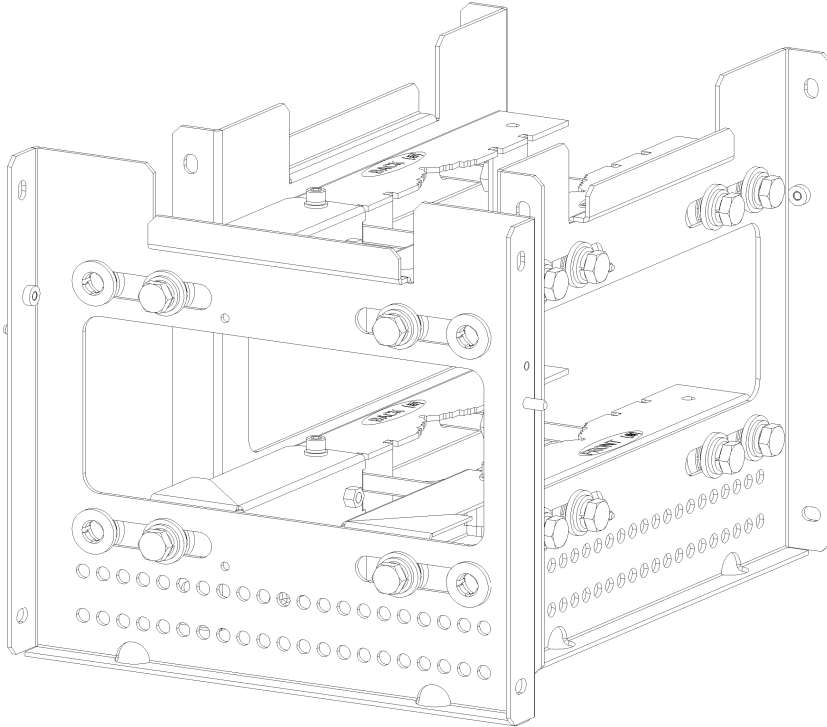
2. Attach the expansion piece to a side of the pole and fasten with M6×60 bolts. Install the lower piece before the higher piece, as shown in Figure 4-33.

Figure 4-33 Mounting the Expansion Piece



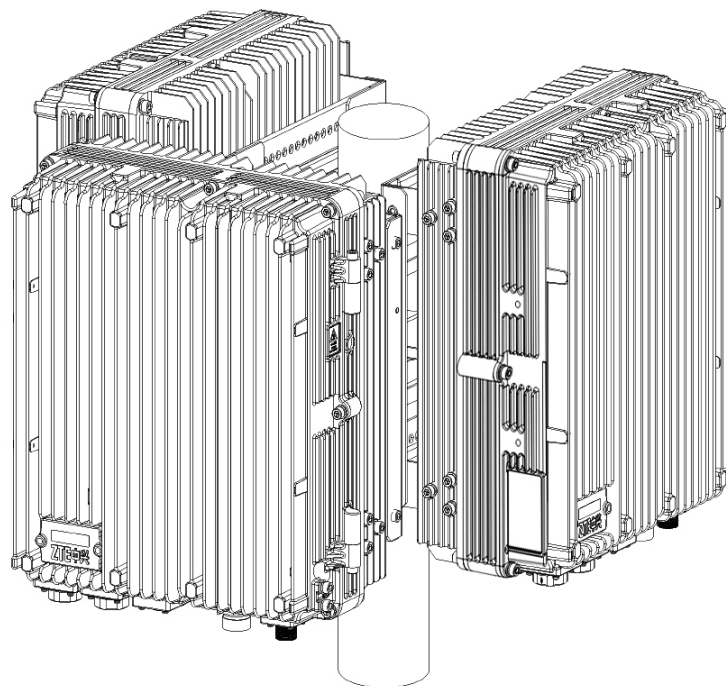
3. Attach the mounting base onto the expansion piece and fasten with the M10×35 bolts, as shown in [Figure 4-34](#).

**Figure 4-34 Attaching the Mounting base**



4. Attach the R8860E GU198 onto the hooks on the mounting base and fasten it with four M6×20 Allen screws, as shown in [Figure 4-35](#).



**Figure 4-35 Attach the R8860E GU198 to the Mounting base**

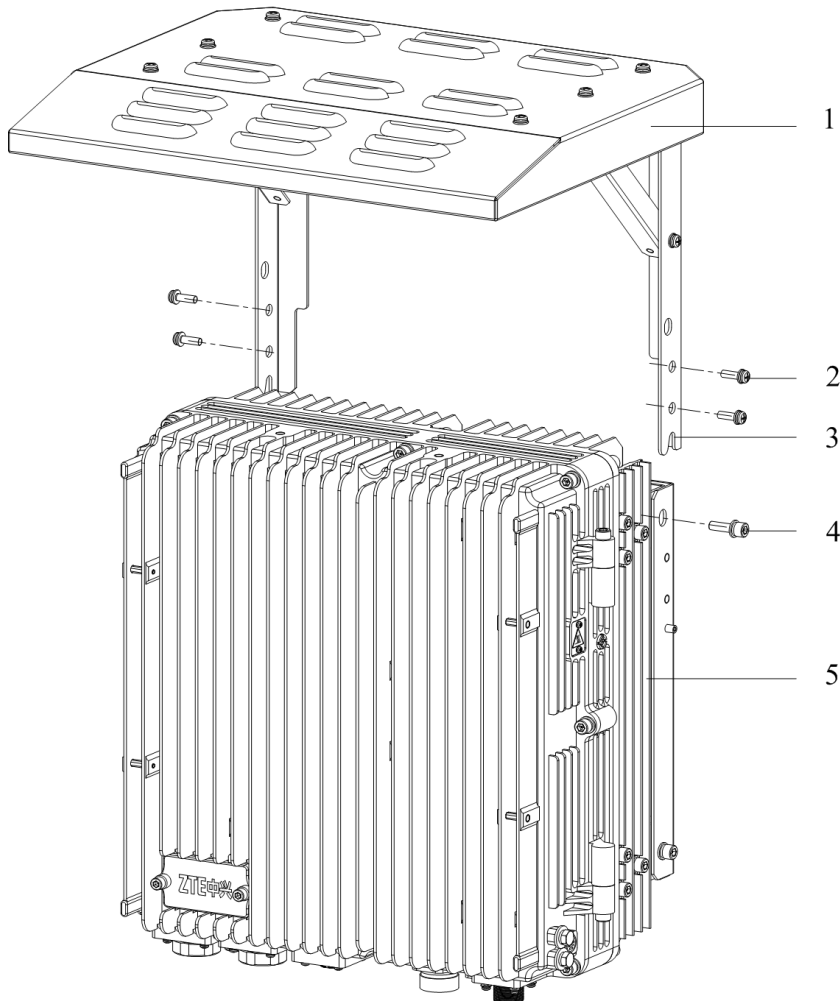
– End of Steps –

#### 4.5.3.4 Installing Protection Shade

##### Steps

1. Hang the R8860E GU198 cabinet on the wall.
2. Fix the protection shade on the 4 fixing positions on the front of R8860E GU198 cabinet, and fasten it on the handles on top of the cabinet with 2 M6 bolts, as shown in [Figure 4-36](#).

Figure 4-36 INSTALLING PROTECTION SHADE



- 1. M6 screw
- 2. Protection shade
- 3. Handle
- 4. Buckle
- 5. R8860E GU198

– End of Steps –

## 4.6 External Cable Installation

### 4.6.1 External Cable Layout

The connection relationship of R8860E GU198 external cables is described in [Table 4-4](#).

Table 4-4 R8860E GU198 External Cable Connection Relationship

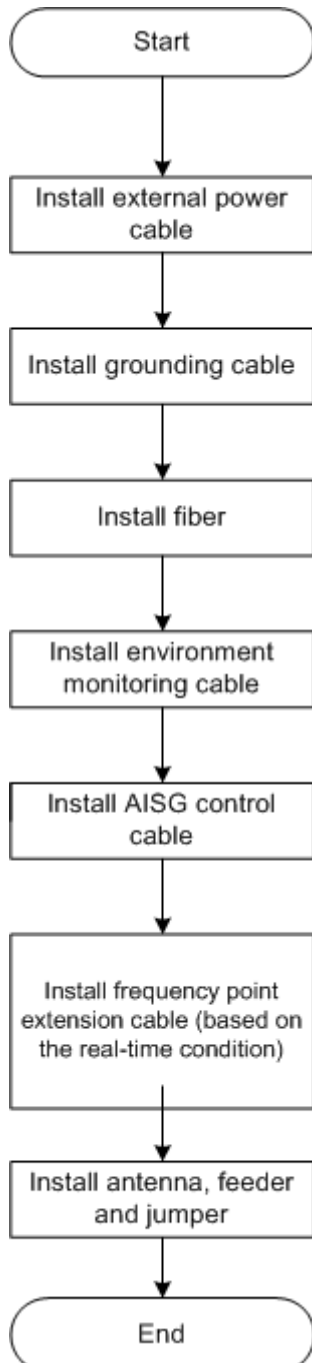
Name	Connection Relationship	Description
Power cable	Connects the R8860E GU198 power interface (DC IN) to the power supply equipment interface	One end is the aviation plug and the other end is reserved for power cable made on site. The length of cable is based on the engineering survey.

Name	Connection Relationship	Description
Grounding cable	Connects one R8860E GU198 ground bolt to the copper bar	The grounding cable is made up of strands of flame-retardant wire. The cross sectional area of R8860E GU198 grounding cable is 10 mm <sup>2</sup> . The color of grounding cable is yellow and green. Copper lugs are crimped at both ends of the R8860E GU198 grounding cable.
Optical Fiber	There are two types of R8860E GU198 fiber: BBU connection / R8860E GU198 cascading.	There are two types of R8860E GU198 optical fiber: one used in BBU connection and the other used in cascading between R8860E GU198s.
Environment monitoring cable	Connects the R8860E GU198 environment monitoring interface MON to the external monitoring components or the dry contact.	A end of the environment monitoring cable is PIN design. B end, with 3 m length in total, needs making based on the on-site engineering.
AISG control cable	Connects the R8860E GU198 debugging interface (AISG) to the control interface of electrical-adjustment antenna.	<b>AISG</b> is used for control of the electrical-adjustment antenna.
Frequency point extension cable	Interconnects the R8860E GU198 RXin/RXout interfaces.	The frequency point extension cable usually adopts the finished 1/2" jumper with 2 m length. The jumper can be self-made based on the real-time condition on site. A and B ends of jumper are N connectors (male).
Antenna, feeder and jumper	Connects the R8860E GU198 to the main feeder.	The RF jumper usually adopts the finished 1/2" jumper with 2 m length. The jumper can be self-made based on the real-time condition on site. The end of jumper is N connector (male) and the other end is DIN connector (female).

## 4.6.2 External Cable Installation Flow

Figure 4-37 lists the installation flow of external cable. This flow can be adjusted based on the real-time condition.

Figure 4-37 External Cable Installation Flow



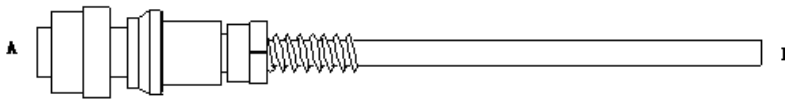
## 4.6.3 Installing Power Cable

### Context

The R8860E GU198 cabinet adopts -48 V DC for power supply. End A is the aviation plug and End B is reserved for self-made power cable on site. The length of power cable is according to the engineering survey.

R8860E GU198 [Figure 4-38](#) shows the structure of power cable.

**Figure 4-38 Power Cable structure**



[Table 4-5](#) describes the colors and specifications of inside core cable.

**Table 4-5 Color and Specification**

Color	Specification
Blue	-48 V
Black	-48 V GND



**Note:**

1. If the two-core cable is adopted, the blue core cable stands for -48 V and the black core cable stands for -48 V GND;
2. If the four-core cable is adopted, the two blue core cables connected in parallel stand for -48 V and the black core cables connected in parallel stand for -48 V GND.

### Steps

1. Connect End A of power cable with DC IN interface located at the bottom of R8860E GU198.
2. Strip the protective coat of End B and connect it with the DC input power source according to colors of the inside core cable.
3. Make waterproof protection of End B.
4. Attach labels at both ends of the power cable.
5. Fix the power cable.

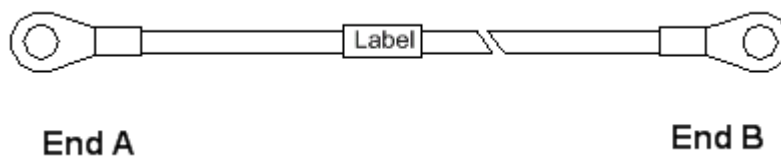
**– End of Steps –**

## 4.6.4 Installing Grounding Cable

### Context

The grounding cable is made up of strands of flame-retardant wire. The cross sectional area of R8860E GU198 grounding cable is  $10 \text{ mm}^2$ . The color of grounding cable is yellow and green. Copper lugs are crimped at both ends of the R8860E GU198 grounding cable, as shown in [Figure 4-39](#).

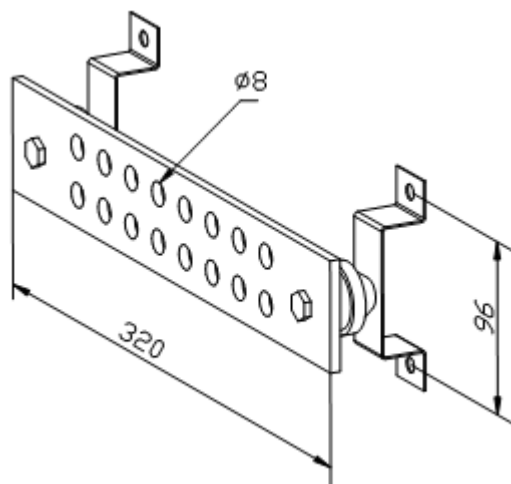
**Figure 4-39 Grounding Cable Structure**



### Steps

1. Cover and fix a copper lug on the a grounding bolt of the R8860E GU198 cabinet.
2. Connect the other copper lug to the earth-networking copper bar and fix it with a bolt, as shown in [Figure 4-40](#).

**Figure 4-40 Earth-network Copper Bar (Unit: mm)**



3. Attach the label on the grounding cable.
4. Measure the grounding resistance and make sure it less than  $5 \Omega$ .

– End of Steps –

## 4.6.5 Installing Fiber between BBU and RRU

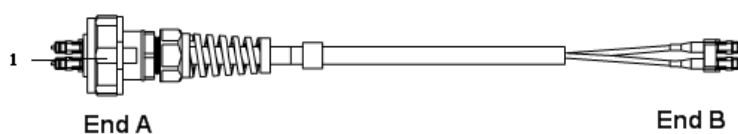
### Prerequisites

The R8860E GU198 cabinet must be installed and fixed successfully.

### Context

Figure 4-41 shows fiber connection between R8860E GU198 and BBU.

**Figure 4-41 Fiber Connection between R8860E GU198 and BBU**



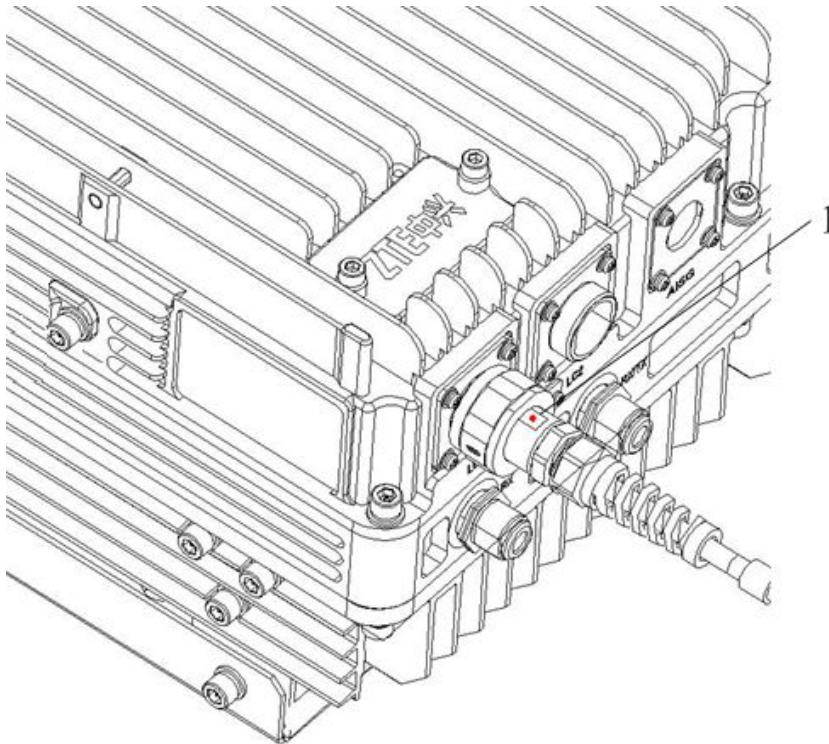
1. Outdoor Seal Component

While connecting a BBU to R8860E GU198, make sure that the baseband RF fiber interface (LC1/2) of the R8860E GU198 is connected to the optical interface connector of the BBU.

### Steps

1. Attach labels at both ends of the fiber.
2. Adjust the side of End A with the color mark and insert the R8860E GU198 fiber interface, and screw down the nuts, as shown in Figure 4-42

**Figure 4-42 Optical Fiber Installation**



1. Color mark
  3. Connect End A of the fiber to the base band RF fiber interface (LC1/2) of the R8860E GU198.
  4. Connect End B of the fiber, which is a DLC connector, to the BBU optical connector.
  5. Screw down the outdoor seal component at End A for waterproofing.
- End of Steps –

## 4.6.6 Installing Fiber between RRU and RRU

### Prerequisites

The cascading R8860E GU198 cabinets must be installed and fixed successfully.

### Context

Figure 4-43 shows fiber connection between R8860E GU198s.

**Figure 4-43 Fiber Connection between R8860E GU198s**



1. Outdoor Seal Component

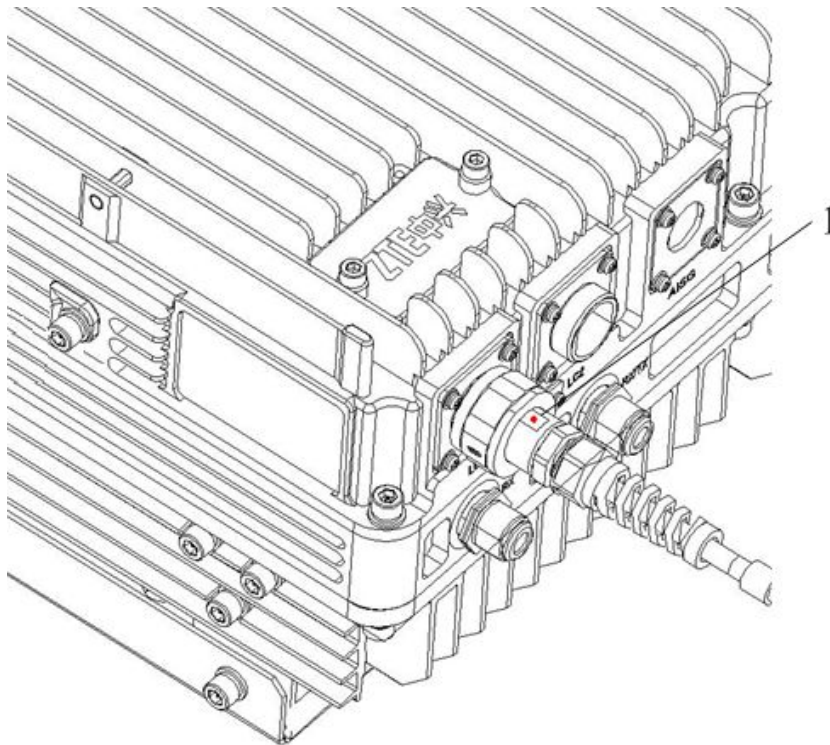


While interconnecting the R8860E GU198s, make sure that the two baseband RF fiber interfaces (LC1/2) of the R8860E GU198 are connected.

### Steps

1. Attach labels at both ends of the optical fiber.
2. Adjust the side of End A with the color mark and insert the R8860E GU198 fiber interface, and screw down the nuts, as shown in [Figure 4-44](#).

**Figure 4-44 Optical Fiber Installation**



1. Color mark
3. Connect End A of the optical fiber to the base band RF fiber interface (LC1/2) of the R8860E GU198.
4. Connect End B of the optical fiber to the other base band RF fiber interface (LC1/2) of the R8860E GU198.
5. Screw down the outdoor seal component at End A for waterproofing.

– End of Steps –

## 4.6.7 Installing Environment Monitoring Cable

### Prerequisites

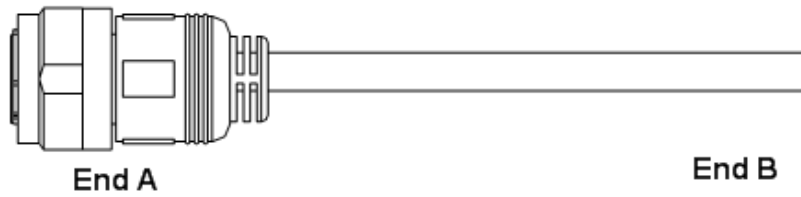
The R8860E GU198 cabinet must be installed and fixed successfully.

**Context**

The environment monitoring cable provides a 485 interface, used for R8860E GU198 environment monitoring. In addition, the cable also provides four extension accesses for external dry contact monitoring.

End A is the 37 PIN connector, and End B is made by on-site engineering. The total length is 3m. Figure 4-45 shows the appearance of environment monitoring cable.

**Figure 4-45 Environment Monitoring Cable**



The connector, connecting the environment monitoring cable to the R8860E GU198, adopts 37-core aviation jack. The connector accords with the GJB599 specification. The connector appearance is as shown in Figure 4-46

**Figure 4-46 Aviation Jack Appearance**

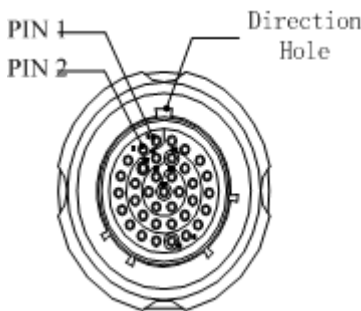


Table 4-6 describes the connector pins.

**Table 4-6 Cable Pin Description**

Pin	Core-Cable Color	Signal Description
15/16	White and blue/blue	Dry contact 4 -/+
17/18	White and orange/orange	Dry contact 3 -/+
19/20	White and green/green	Dry contact 2 -/+
21/22	White and brown/brown	Dry contact 1 -/+
23/24	Red and blue/blue	RS485 receive
25/26	Red and orange/orange	RS485 transmit

**Steps**

1. Connect End A to the MON interface located at the bottom of R8860E GU198.

2. Connect End B with external monitoring devices or dry contacts.
3. Attach the label at End B.

– End of Steps –

## 4.6.8 Installing AISG Control Cable

### Context

The AISG control cable is used for control of the electrical adjustment antenna.

Figure 4-47 shows the structure of the AISG control cable.

**Figure 4-47 AISG Control Cable Structure**

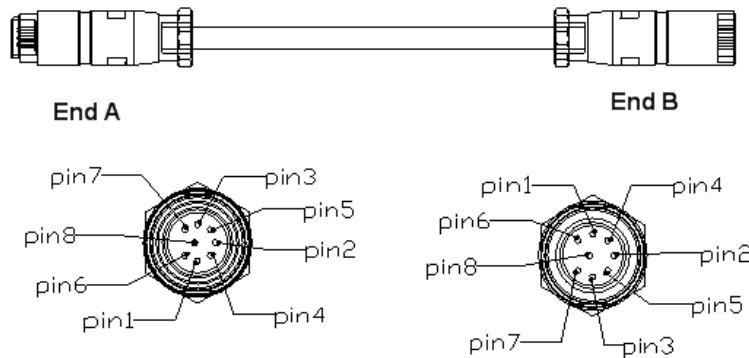


Table 4-7 describes the serial No. meaning of AISG control cable.

**Table 4-7 AISG Control Cable Description**

Serial No.	Name	Meaning
1	TRX_ANT_485_+	RS485+
2	TRX_ANT_485_-	RS485-
3,4	TRX_ANT_28 V	28 V
5,6	TRX_ANT_28 V GND	28 V GND
7,8	NC	Null

### Steps

1. Connect End A to the R8860E GU198 debugging interface (AISG) and screw down the bolt;
2. Connect End B to the control interface of electrical adjustment antenna and screw down the bolt.

– End of Steps –

## 4.6.9 Installing Frequency Point Extension Cable

### Prerequisites

The two R8860E GU198 cabinets to be combined must be installed and fixed successfully.

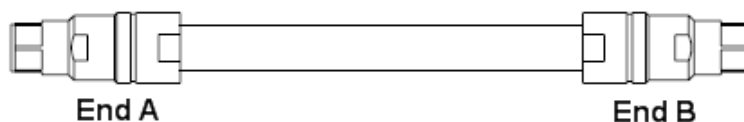
### Context

After the combination of cabinets, the R8860E GU198 can support 8 carrier sectors at most.

The two R8860E GU198 cabinets are connected through their connecting interfaces such as RXin and RXout by two frequency point extension cables. [Figure 4-48](#) shows the structure of the frequency point cable. End A and End B are N connectors (male).

The 2M 1/2" jumper is often used for the frequency point extension cable. It may be prepared on site if necessary.

**Figure 4-48 Frequency Point Extension Cable**



### Steps

1. Connect End A of the frequency point extension cable to the frequency point extension interface RXIN of one R8860E GU198;
2. Connect End B to RXout of the other R8860E GU198;
3. Connect the remaining RXin/RXout interfaces of the two combined cabinets with the other frequency point extension cable.

– End of Steps –

## 4.6.10 Installing Jumper

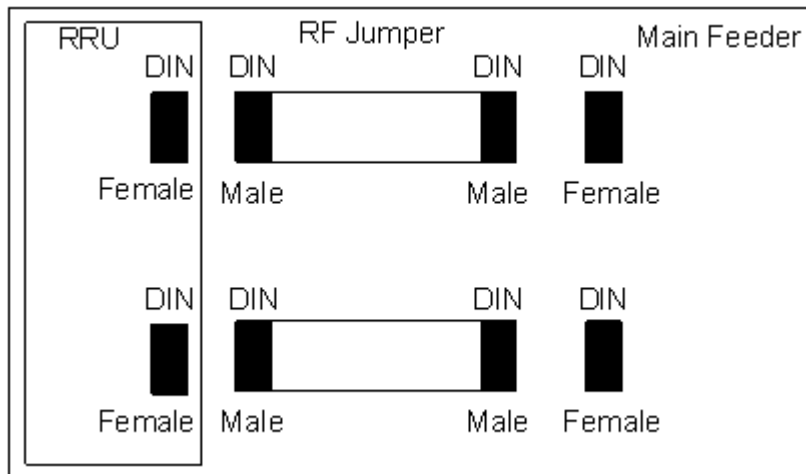
### Context

One end of RF jumper connects with the main feeder and the other end connects with the antenna feeder interface of R8860E GU198 cabinet. Before installing the RF jumper, the main feeder is installed.

The RF jumper adopts the 1/2" jumper with a 2 m length. The jumper can also be self-made according to the on-site condition.

The installation position of RF jumper is as shown in [Figure 4-49](#).

Figure 4-49 RF Jumper Installation



Perform the following steps to install the RF jumper.

### Steps

1. Connect the DIN connector (male) of RF jumper with the DIN connector (female) of main feeder.
2. Connect the DIN connector (male) of RF jumper with the DIN connector (female) of R8860E GU198 cabinet.
3. Seal the connectors with waterproof adhesive tapes and PVC tapes.

– End of Steps –

## 4.7 Hardware Installation Inspection

### 4.7.1 Checking Cabinet Installation

#### Steps

1. Ensure that the cabinet installation position complies with the engineering design drawing.
2. Erect cabinet firmly so as to resist an earthquake measuring up to 7.0 on Richter scale.
3. Ensure that horizontal and vertical error is less than 3 mm.
4. Ensure that cabinet surface is clean and tidy and covered well by oil paint. All parts of the cabinet are complete and all marking on the cabinet are correct, clear and complete.
5. Ensure all screws are fixed tight with flat washers or spring washers.

– End of Steps –

## 4.7.2 Checking Cable Installation

### 4.7.2.1 Cables Installation General Specification

#### Optical Fiber



**Note:**

The length of optical fiber is decided by engineering survey (1 Tx, 1 Rx).

The technical specifications of optical fiber are as follows:

- The optical fiber is a single mode with End B adopting two DLC/PC connectors.
- The insertion loss is less than 0.3 dB.
- The return loss is less than 45 dB.
- If optical fiber is to be used outdoor, then
  1. Take waterproof and anti-ultraviolet protection measures.
  2. Make sure that working temperature is in between -40 to 80°C.
- The sheath of optical fiber is black in color with a diameter of 7 mm. Under the sheath, there are two cores optical wires (yellow and blue color) with substantial amount of protection padding.
- The maximum distance between core optical wires (including both DLC/PC connectors) and sheathed optical fiber is 350 mm.
- ZTE supplies 15 m, 25 m, 35 m, 50 m, 70 m, 100 m, and 130 m long fiber cables.
- The 20 mm long black Pyrocondensation cannula should be added in between optical core wires and sheathed optical fiber.
- The label attached at both ends should satisfy the requirements of *ZTE Cable Designing Criteria – Label Designing and Usage Requirements*.

#### AISG Cable

The following are the technical specification of AISG cable:

- [Table 4-8](#) illustrates the connection relationship of both ends. Make sure to enclose End A connection by black cannula completely after connecting.

**Table 4-8 Connection Relationship**

Serial Number	Signal Definition	End A Pin Number	End B Pin Number	Connected Cable
1	485+	Pin 3	Pin 1	-
2	485-	Pin 5	Pin 2	-

Serial Number	Signal Definition	End A Pin Number	End B Pin Number	Connected Cable
3	28 V	Pin 6	Pin 3, 4	Two cables from Pin6 of A end are welded to Pin 3 and 4 of B end.
4	28 V GND	Pin 7	Pin 5, 6	Two cables from Pin7 of A end are welded to Pin 5 and 6 of B end.

- The Pin 6 and Pin 7 (See [Table 4-8](#)) are needed to be welded with two cables.
- The End A connector should be equipped with metal dust-proof cover
- The labels printing and pasting should satisfy the requirements of *Q/ZX04.113.4 Cable Designing Criteria – Label Designing and Usage Requirements*.

### Monitoring Cable

The following are the technical specification of monitoring cable:

- The End A is a 37-pin female connector.
- End B is an open end without any connector. The connector at the End B should be prepared on-site according to the on-site requirements.
- Make sure that connector at the End A is properly welded.
- The label attached at both ends should satisfy the requirements of *ZTE Cable Designing Criteria – Label Designing and Usage Requirements*.
- [Table 4-9](#) shows the connection relationship of End A.

**Table 4-9 Connection Relationship**

End A (Pins)	Color	Signal Definition
15/16	White/blue	Dry contact 4 - / +
17/18	White/orange	Dry contact 3 - / +
19/20	White/green	Dry contact 2 - / +
21/22	White/brown	Dry contact 1 - / +
23/24	Red/blue	485 Rx - / +
25/26	Red/orange	485 Tx - / +
Other Pins are free	Other core wires are free	

## 4.7.2.2 Power and Grounding Cables Installation Check

### Context

Ensure the power and grounding cables installation is done in accordance with the following checks:

**Steps**

1. The power and grounding cables are laid separately from other cables. If the power and grounding cables are to be laid parallel with other cables, then at least a distance of 20 cm is maintained between them.
2. The cable labels are intact on both sides of power and grounding cables. The labels are attached at almost 2 cm from cable copper lug.
3. Entire power and grounding cables are made from one material with no connections in between.
4. A single grounding point on the grounding busbar just connects to a piece of equipment.
5. Copper lugs on both ends of power and grounding cables are soldered or pressed firmly.
6. The shortest route between the grounding cables and grounding busbar is adopted.
7. Power and grounding cables at connecting terminals and lug handles are properly insulated using either insulated tapes or heat shrink tubes.
8. The redundant length of power and grounding cables is cut to avoid wrapping each other.

– End of Steps –

**4.7.2.3 Optical Fiber Installation Check****Context**

The fiber cable installation should meet the following specifications:

**Steps**

1. Do not fold optical fiber at 90°. For optical fiber that is to be laid outdoors, minimal twist radius should be at least greater than 90 mm. Whereas for optical fiber that is to be laid indoors, minimal twist radius should be at least greater than 30 mm.
2. After installation, any surplus optical fiber should be put back in the fiber card for convenience.
3. During installation, minimize optical fiber twist and turn, as much as possible.
4. The binding force should be proper to ensure that binding gaps are less 0.5 m.
5. Make sure that labels at both ends of optical fiber are intact and clear.

– End of Steps –



## 4.7.3 Checking Main Antenna System Installation

### Steps

1. Ensure the height of antenna is consistent with the network planning, and the installation position is consistent with the engineering design drawing.
2. Ensure the azimuth and down-tilt of the antenna is consistent with the engineering design drawing.
3. Ensure the antenna is within the protection area of lightning rod.
4. Ensure the VSWR not more than 1.5.
5. Ensure proper connection between antenna and jumper as well as between jumper and main feeder correct.
6. Make sure that the jumper and antenna at the junction keep straight within 30cm at least.

– End of Steps –

## 4.8 Power on and off

### 4.8.1 Power on Preparation

#### Context

Make sure that following conditions are fulfilled before powering-on R8860E GU198:

#### Steps

1. Make sure that input power supply is within the acceptable range.
2. Make sure that power cable connected to R8860E GU198 cabinet is properly grounded.

– End of Steps –

#### Result

The preparation to power on the cabinet is successfully completed.

### 4.8.2 Power ON

#### Context

Perform the following steps to power-on the R8860E GU198.

**Steps**

1. There is no power switch ON the R8860E GU198 cabinet. Close the external power switch to power on R8860E GU198.
2. During power ON, if some abnormal phenomena occurs, disconnect the external power switch or the plug immediately, and check the reason.

– End of Steps –

## 4.8.3 Power OFF

**Context**

Perform the following steps to power OFF the R8860E GU198.

**Steps**

1. There is no power switch on the R8860E GU198 cabinet. Disconnect the external power switch to power off R8860E GU198.

– End of Steps –

# Chapter 5

## RRU Connections with Antenna Feeder System

---

### Table of Contents

Typical Single-RRU Antenna Feeder System Configurations .....	5-1
Configuring RRU with Common Antennas and Without ADTMA .....	5-1
Configuring RRU with Common Antennas and ADTMA .....	5-2
Configuring RRU with Electrical Antennas and Without ADTMA (I) .....	5-3
Configuring RRU with Electrical Antennas and Without ADTMA (II) .....	5-4
Configuring RRU with Electrical Antennas and ADTMA .....	5-5

## 5.1 Typical Single-RRU Antenna Feeder System Configurations

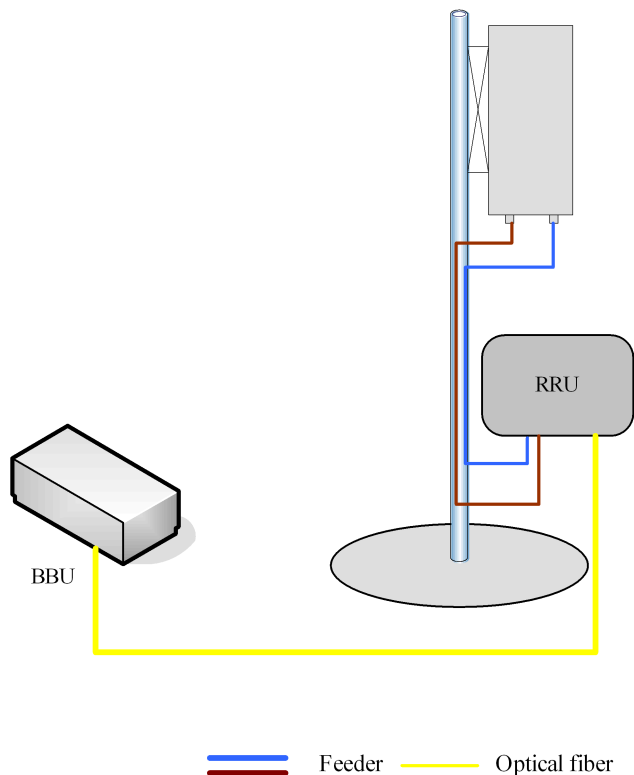
The typical configurations of a single-RRU feeder system are as follows:

- The RRU is configured with common antennas
- The RRU is configured with common antennas and AISG dual Tower Mounted Amplifier (ADTMA)
- The RRU is configured with electrical antennas (I)
- The RRU is configured with electrical antennas (II)
- The RRU is configured with electrical antennas and ADTMA

## 5.2 Configuring RRU with Common Antennas and Without ADTMA

Install the RRU close to the antenna on the rooftop. Directly connect the RRU to the antenna through 1/2" feeders, or in some situations, 5/4" or 7/8" feeders.

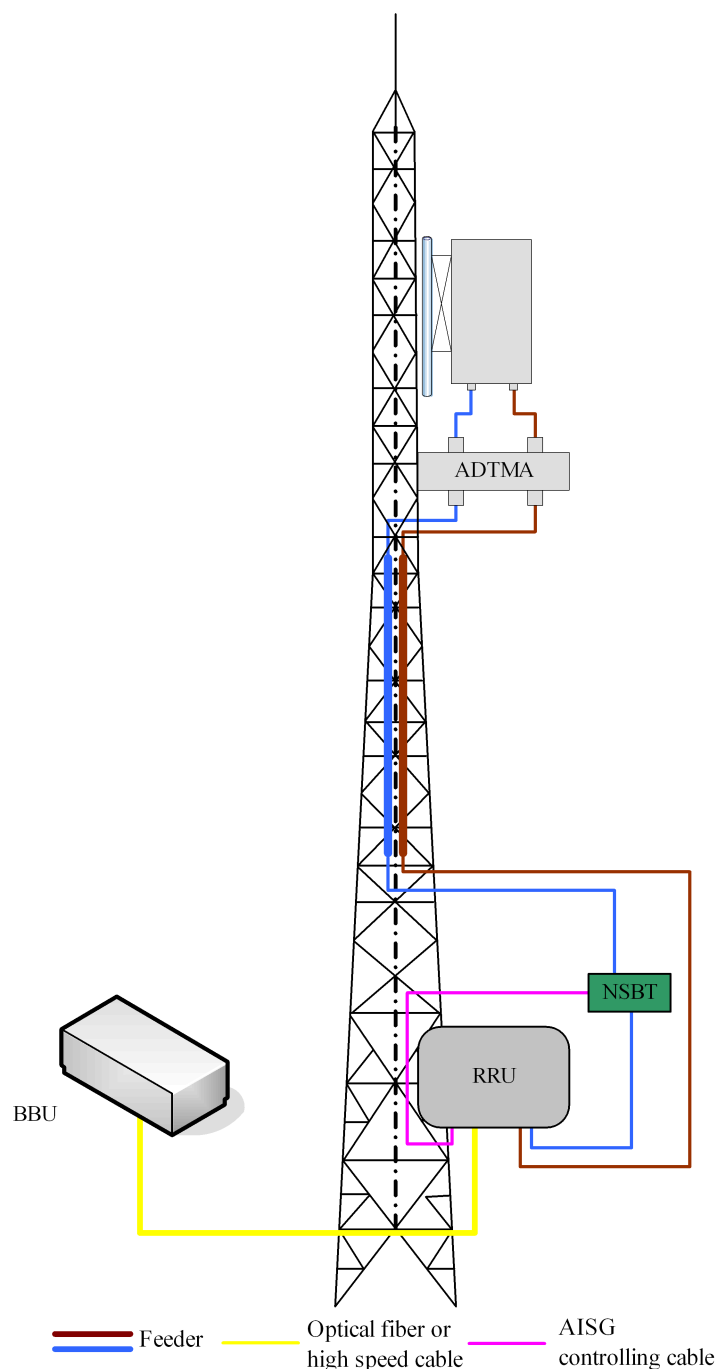
Figure 5-1 CONNECTING RRU TO COMMON ANTENNAS WITHOUT TWA



### 5.3 Configuring RRU with Common Antennas and ADTMA

Install the RRU under the tower and install the antenna on the tower. Connect the RRU to the antenna through 5/4" or 7/8" feeders.

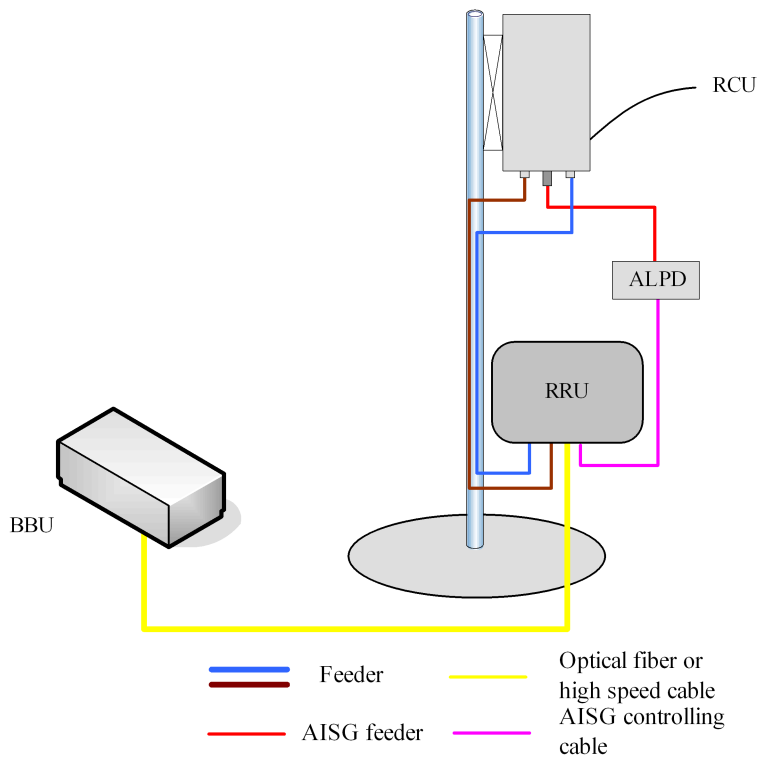
Figure 5-2 CONNECTING RRU TO COMMON ANTENNAS AND ADTMA



## 5.4 Configuring RRU with Electrical Antennas and Without ADTMA (I)

Install the RRU close to the antenna on the rooftop. Connect the RRU to the antenna through 1/2" feeders, or in some situations, 5/4" or 7/8" feeders.

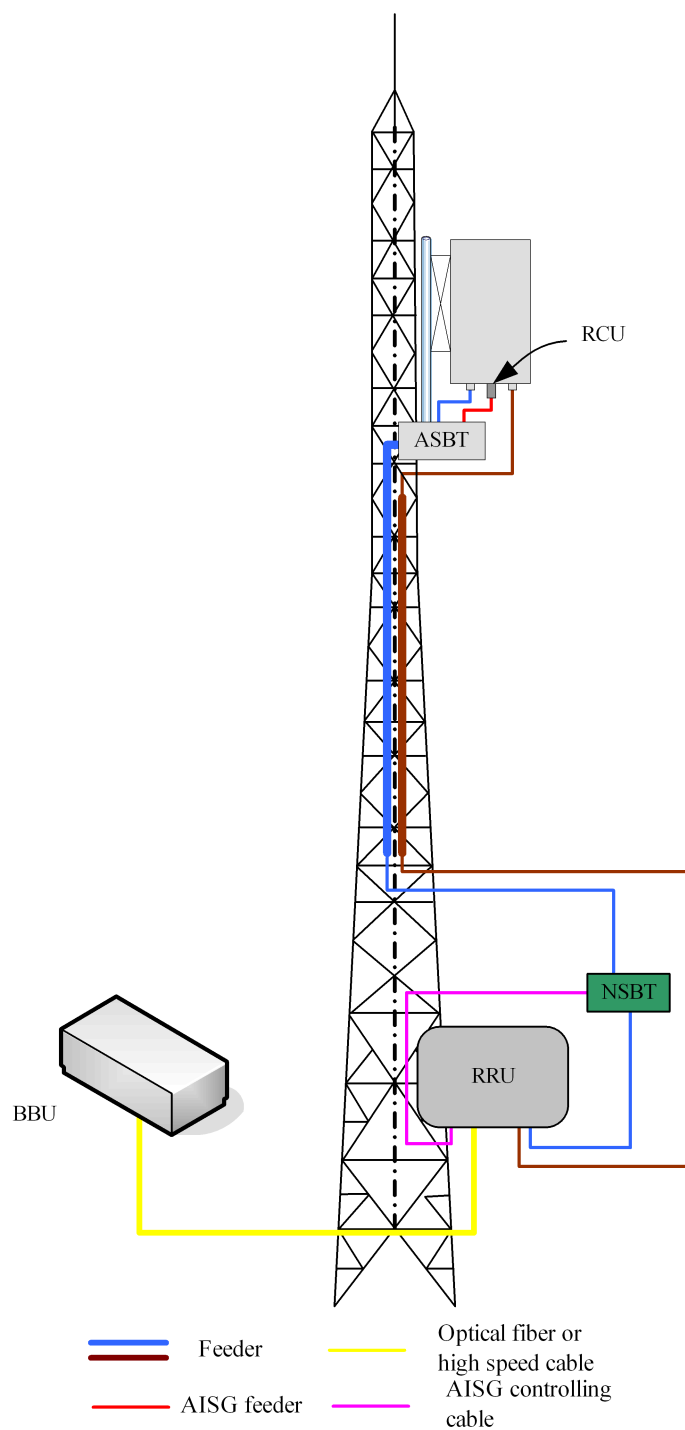
Figure 5-3 CONNECTING RRU WITH ELECTRICAL ANTENNAS (I)



## 5.5 Configuring RRU with Electrical Antennas and Without ADTMA (II)

Install the RRU under the tower and install the antenna on the tower. Connect the RRU to the antenna through 5/4" or 7/8" feeders.

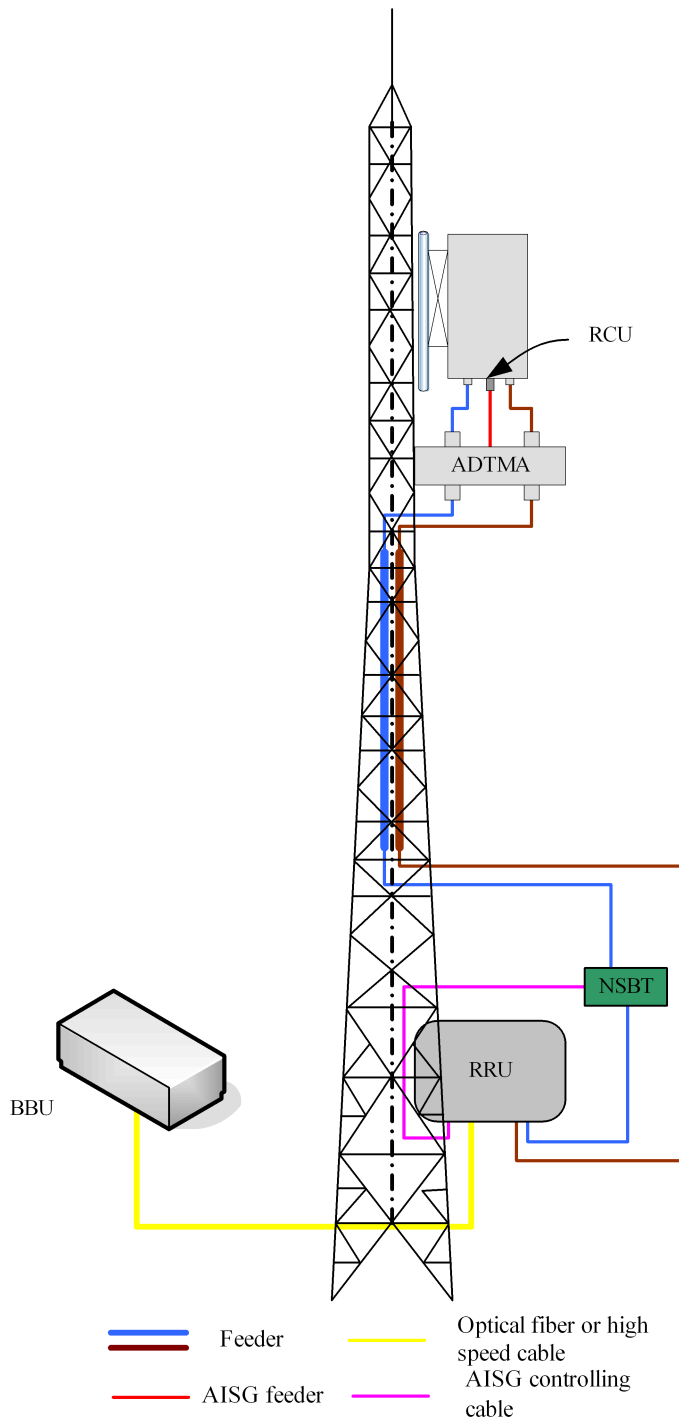
Figure 5-4 CONNECTING RRU WITH ELECTRICAL ANTENNAS (II)



## 5.6 Configuring RRU with Electrical Antennas and ADTMA

Install the RRU under the tower and install the antenna on the tower. Connect the RRU to the antenna through 5/4" or 7/8" feeders.

Figure 5-5 CONNECTING RRU TO ELECTRICAL ANTENNAS AND ADTMA





# Figures

---

Figure 1-1	R8860E GU198 POSITION IN GSM/UMTS NETWORK .....	1-2
Figure 1-2	BASE STATION (BBU AND RRU).....	1-2
Figure 1-3	DISTRIBUTED BASE STATION SYSTEM STRUCTURE .....	1-3
Figure 1-4	RUNNING ENVIRONMENT OF R8860E GU198 .....	1-4
Figure 1-5	R8860E GU198 Appearance .....	1-5
Figure 1-6	OPERATION AND MAINTENANCE OF R8860E GU198 .....	1-9
Figure 3-1	External Interfaces at Chassis Bottom .....	3-1
Figure 3-2	R8860E GU198 Indicators and Buttons.....	3-3
Figure 3-3	HARDWARE SYSTEM .....	3-4
Figure 3-4	R8860E GU198 SOFTWARE ARCHITECTURE .....	3-7
Figure 4-1	PACKING OF R8860E GU198 .....	4-16
Figure 4-2	FLOW OF UNPACKING AND CHECKING.....	4-17
Figure 4-3	R8860E GU198 Installation Flow .....	4-18
Figure 4-4	Taking out Cabinet.....	4-19
Figure 4-5	Binding Cabinet with Rope.....	4-19
Figure 4-6	Hoisting Operation Schematic Diagram.....	4-20
Figure 4-7	WALL MOUNTED INSTALLATION FOR R8860E GU198.....	4-24
Figure 4-8	POLE MOUNTED INSTALLATION FOR 1 OR 2 R8860E GU198s .....	4-25
Figure 4-9	POLE MOUNTED INSTALLATION FOR 3 R8860E GU198s .....	4-25
Figure 4-10	The Single R8860E GU198 Mounting Solution.....	4-26
Figure 4-11	The Double R8860E GU198 Mounting Solution.....	4-26
Figure 4-12	The Triple R8860E GU198 Mounting Solution.....	4-27
Figure 4-13	R8860E GU198 INSTALLATION FLOW.....	4-28
Figure 4-14	HOLING TEMPLATE .....	4-29
Figure 4-15	ASSEMBLING WALL-MOUNTED INSTALLATION ASSEMBLY .....	4-30
Figure 4-16	FIXING THE CABINET .....	4-31
Figure 4-17	INSTALLING CLAMP ASSEMBLY .....	4-32
Figure 4-18	FIXING THE CABINET .....	4-33
Figure 4-19	INSTALLING CLAMP ASSEMBLY .....	4-34
Figure 4-20	ASSEMBLING WALL-MOUNTED INSTALLATION ASSEMBLY .....	4-35
Figure 4-21	FIXING THE CABINET .....	4-35

Figure 4-22	INSTALLING MOUNTING BRACKET ASSEMBLY .....	4-36
Figure 4-23	ASSEMBLING WALL-MOUNTED INSTALLATION ASSEMBLY .....	4-37
Figure 4-24	FIXING THE CABINET .....	4-37
Figure 4-25	Fixing the Mounting Piece .....	4-38
Figure 4-26	Mounting R8860E GU198 .....	4-39
Figure 4-27	Mounting base Double Unit Solution .....	4-40
Figure 4-28	Mounting base Single Unit + Lightning Protector Box Solution .....	4-40
Figure 4-29	Mounting Two R8860E GU198 .....	4-41
Figure 4-30	Mounting one R8860E GU198 and One Lightning Protector Box .....	4-42
Figure 4-31	Fixing the Lightning Protector Box .....	4-42
Figure 4-32	Mounting Two R8860E GU198 .....	4-43
Figure 4-33	Mounting the Expansion Piece .....	4-43
Figure 4-34	Attaching the Mounting base .....	4-44
Figure 4-35	Attach the R8860E GU198 to the Mounting base .....	4-45
Figure 4-36	INSTALLING PROTECTION SHADE .....	4-46
Figure 4-37	External Cable Installation Flow .....	4-48
Figure 4-38	Power Cable structure .....	4-49
Figure 4-39	Grounding Cable Structure .....	4-50
Figure 4-40	Earth-network Copper Bar (Unit: mm) .....	4-50
Figure 4-41	Fiber Connection between R8860E GU198 and BBU .....	4-51
Figure 4-42	Optical Fiber Installation .....	4-52
Figure 4-43	Fiber Connection between R8860E GU198s .....	4-52
Figure 4-44	Optical Fiber Installation .....	4-53
Figure 4-45	Environment Monitoring Cable .....	4-54
Figure 4-46	Aviation Jack Appearance .....	4-54
Figure 4-47	AISG Control Cable Structure .....	4-55
Figure 4-48	Frequency Point Extension Cable .....	4-56
Figure 4-49	RF Jumper Installation .....	4-57
Figure 5-1	CONNECTING RRU TO COMMON ANTENNAS WITHOUT TWA .....	5-2
Figure 5-2	CONNECTING RRU TO COMMON ANTENNAS AND ADTMA .....	5-3
Figure 5-3	CONNECTING RRU WITH ELECTRICAL ANTENNAS (I) .....	5-4
Figure 5-4	CONNECTING RRU WITH ELECTRICAL ANTENNAS (II) .....	5-5
Figure 5-5	CONNECTING RRU TO ELECTRICAL ANTENNAS AND ADTMA .....	5-6

# Tables

---

Table 1-1	EQUIPMENTS RELATED TO R8860E GU198 RUNNING.....	1-4
Table 2-1	Wind Speed @ 150 km/h.....	2-2
Table 2-2	Wind Speed @ 240 km/h.....	2-2
Table 3-1	External Interfaces .....	3-2
Table 3-2	Indicators and Buttons.....	3-3
Table 3-3	COMPOSITION OF M8206 CABINET HARDWARE.....	3-5
Table 4-1	Safety Symbols Description.....	4-3
Table 4-2	Tool and Meter List.....	4-10
Table 4-3	INSTALLATION ACCESSORIES OF R8860E GU198 AND THEIR FUNCTIONS.....	4-22
Table 4-4	R8860E GU198 External Cable Connection Relationship.....	4-46
Table 4-5	Color and Specification.....	4-49
Table 4-6	Cable Pin Description.....	4-54
Table 4-7	AISG Control Cable Description .....	4-55
Table 4-8	Connection Relationship.....	4-58
Table 4-9	Connection Relationship.....	4-59

This page intentionally left blank.

# Glossary

---

**AISG**

- Antenna Interface Standards Group

**Abis**

- Abis Interface between BSC and BTS

**BBU**

- BaseBand Unit

**BSC**

- Base Station Controller

**BTS**

- Base Transceiver Station

**CN**

- Core Network

**DPD**

- Digital Pre-Distortion

**EDGE**

- Enhanced Data rates for GSM Evolution

**FP**

- Frame Protocol

**GPRS**

- General Packet Radio Service

**GPS**

- Global Positioning System

**GSM**

- Global System for Mobile Communication

**HSPA**

- High Speed Packet Access

**Iub**

- Interface between an RNC and a Node B

**LTE**

- Long Term Evolution

**MS**

- Mobile Station

**Node B**

- Node B

**OAM**

- Operation, Administration and Maintenance

**PA**

- Power Amplifier

**RF**

- Radio Frequency

**RNC**

- Radio Network Controller

**RRU**

- Remote Radio Unit

**UE**

- User Equipment

**UMTS**

- Universal Mobile Telecommunication System

**Uu**

- U interface in mobile network