



ZXSDR R8860E GU858

Outdoor GSM&UMTS Dual Mode Macro RRU

User Manual

HV2.0

ZTE CORPORATION
NO. 55, Hi-tech Road South, ShenZhen, P.R.China
Postcode: 518057
Tel: (86) 755 26771900
Fax: (86) 755 26770801
URL: <http://ensupport.zte.com.cn>
E-mail: support@zte.com.cn

LEGAL INFORMATION

Copyright © 2010 ZTE CORPORATION.

The contents of this document are protected by copyright laws and international treaties. Any reproduction or distribution of this document or any portion of this document, in any form by any means, without the prior written consent of ZTE CORPORATION is prohibited. Additionally, the contents of this document are protected by contractual confidentiality obligations.

All company, brand and product names are trade or service marks, or registered trade or service marks, of ZTE CORPORATION or of their respective owners.

This document is provided “as is”, and all express, implied, or statutory warranties, representations or conditions are disclaimed, including without limitation any implied warranty of merchantability, fitness for a particular purpose, title or non-infringement. ZTE CORPORATION and its licensors shall not be liable for damages resulting from the use of or reliance on the information contained herein.

ZTE CORPORATION or its licensors may have current or pending intellectual property rights or applications covering the subject matter of this document. Except as expressly provided in any written license between ZTE CORPORATION and its licensee, the user of this document shall not acquire any license to the subject matter herein.

ZTE CORPORATION reserves the right to upgrade or make technical change to this product without further notice. Users may visit ZTE technical support website <http://ensupport.zte.com.cn> to inquire related information.

The ultimate right to interpret this product resides in ZTE CORPORATION.

Revision History

Revision No.	Revision Date	Revision Reason
R1.0	2010-12-06	First edition
R1.1	2010-12-14	Updated
R1.2	2010-12-20	Updated

Serial Number: SJ-20101210110401-001

Publishing Date: 2010-12-06

Contents

About This Manual	I
Chapter 1 System Overview	1-1
1.1 System Background	1-1
1.2 System Positions.....	1-1
1.2.1 System Position in Network.....	1-1
1.2.2 BBU and RRU.....	1-2
1.3 System Running Environment.....	1-3
1.4 RRU Appearance	1-5
1.5 System Features	1-5
1.6 Services and Functions	1-6
1.7 System Operation and Maintenance	1-8
Chapter 2 Technical Indices	2-1
2.1 Physical Indices	2-1
2.2 Radio Performance Indices.....	2-2
2.3 Interface and Transmission Indices.....	2-3
Chapter 3 Structure and Principles	3-1
3.1 Structure Layout.....	3-1
3.1.1 External Interfaces	3-1
3.1.2 Indicators and Buttons.....	3-2
3.2 Hardware Principle.....	3-4
3.2.1 Hardware Architecture	3-4
3.2.2 Board Functions.....	3-5
3.3 Software System.....	3-7
3.3.1 Software Architecture	3-7
3.3.2 Software Functions.....	3-7
Chapter 4 Installation.....	4-1
4.1 Safety Description	4-1
4.1.1 Safety Specifications Guide	4-1
4.1.2 Safety Symbols	4-2
4.1.3 Safety Instructions.....	4-3
4.2 Preparation.....	4-7
4.2.1 Engineering Condition Inspection	4-7
4.2.2 Requirements to Onsite Personnel	4-8

4.2.3	Technical Document Preparation	4-9
4.2.4	Tools and Instruments Preparation	4-9
4.3	Unpacking and Checking	4-15
4.3.1	Container of R8860E GU858.....	4-15
4.3.2	Flow of Unpacking and Checking	4-16
4.4	Installation Overview	4-17
4.4.1	Installation Flow	4-17
4.4.2	Hoisting Operation Instructions.....	4-17
4.5	Cabinet Installation.....	4-20
4.5.1	Installation Mode Instruction.....	4-20
4.5.2	Installation Methods and Accessories	4-21
4.5.3	R8860E GU858 Installation.....	4-27
4.6	External Cable Installation	4-46
4.6.1	External Cable Layout	4-46
4.6.2	External Cable Installation Flow	4-48
4.6.3	Installing Power Cable	4-49
4.6.4	Installing Grounding Cable.....	4-50
4.6.5	Installing Fiber between BBU and RRU.....	4-51
4.6.6	Installing Fiber between RRU and RRU	4-52
4.6.7	Installing Environment Monitoring Cable	4-53
4.6.8	Installing AISG Control Cable.....	4-55
4.6.9	Installing Frequency Point Extension Cable.....	4-56
4.6.10	Installing Jumper	4-56
4.7	Hardware Installation Inspection.....	4-57
4.7.1	Checking Cabinet Installation.....	4-57
4.7.2	Checking Cable Installation.....	4-58
4.7.3	Checking Main Antenna System Installation.....	4-61
4.8	Power on and off.....	4-61
4.8.1	Power on Preparation.....	4-61
4.8.2	Power ON.....	4-61
4.8.3	Power OFF	4-62
Chapter 5 RRU Connections with Antenna Feeder System		5-1
5.1	Typical Single-RRU Antenna Feeder System Configurations	5-1
5.2	Configuring RRU with Common Antennas and Without ADTMA	5-1
5.3	Configuring RRU with Common Antennas and ADTMA.....	5-2
5.4	Configuring RRU with Electrical Antennas and Without ADTMA (I)	5-3
5.5	Configuring RRU with Electrical Antennas and Without ADTMA (II)	5-4

5.6 Configuring RRU with Electrical Antennas and ADTMA.....	5-5
Figures	I
Tables	III
Glossary	V

About This Manual

Purpose

This manual introduce the working principle, structure features, networking scheme and installation methods of ZXSDR R8860E GU858.

Intended Audience

- System Engineer
- Installation Engineer
- Maintenance Engineer

What Is in This Manual

This manual contains the following chapters.

Chapter	Description
Chapter 1, Product Overview	This chapter describes product's function, specification, features and technical specifications.
Chapter 2, Hardware Description	This chapter describes product's module function and work principle, cables's structure and main antenna system.
Chapter 3, Protocol Interface Description	This chapter describes product's protocol interfaces.

Chapter 1

System Overview

Table of Contents

System Background	1-1
System Positions.....	1-1
System Running Environment	1-3
RRU Appearance	1-5
System Features	1-5
Services and Functions	1-6
System Operation and Maintenance.....	1-8

1.1 System Background

R8860E GU858 is the outdoor dual-mode RF remote unit in the ZTE ZXSDR series base station products.

ZTE Corporation has launched a series of base station products to satisfy various requirements of operators. One of the solutions is dividing the base station into two parts: Base Band Unit (BBU) and Remote Radio Unit (RRU). R8860E GU858 is the outdoor RRU, and it works with BBU to realize complete logical functions of a base station.

R8860E GU858 adopts the multi-carrier technology as its core technology. It supports two radio systems: GSM and UMTS. R8860E GU858 can be used as an independent RRU for GSM or an independent RRU for UMTS, and it works with BBU to form the dual-mode base station.

1.2 System Positions

1.2.1 System Position in Network

The GSM/UMTS system consists of four parts:

- Base station (BTS/Node B)
- Radio network controller (BSC/RNC)
- Core Network (CN) system
- Mobile station (MS/UE)

Figure 1-1 shows the position of R8860E GU858 in the GSM/UMTS network.

Figure 1-1 R8860E GU858 POSITION IN GSM/UMTS NETWORK

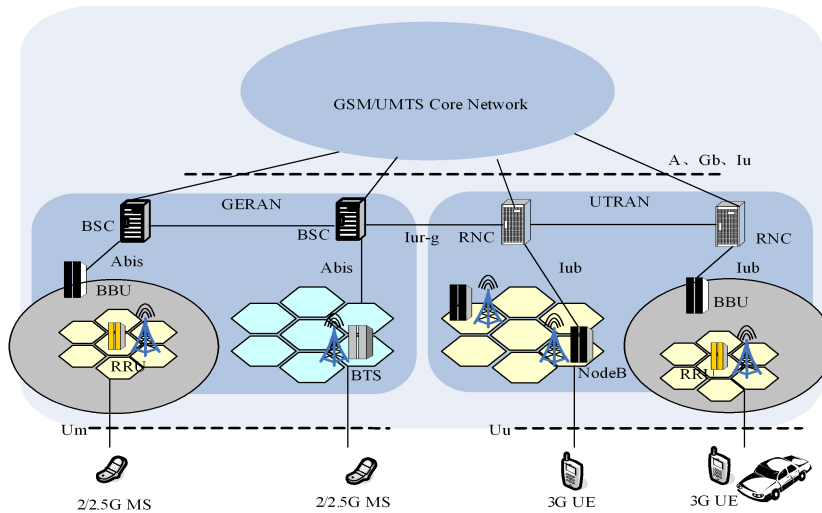

BTS/Node B, which provides the radio coverage of GSM/UMTS network, performs the following functions:

- Realizes MS/UE access and radio link transmission through Um/Uu interface.
- Connects with BSC/RNC through Abis/Iub interface, reports BTS/Node B measurement information, broadcasts system information provided by BSC/RNC, executes commands issued by BSC/RNC (such as access control, mobility management, and radio resource management), and performs FP processing and transmission management.

The distributed BTS/Node B system consists of BBU and RRU. R8860E GU858 realizes the function of RRU, and works with the dual-mode BBU to form the BTS/Node B base station.

1.2.2 BBU and RRU

Functions

Figure 1-2 shows the base station structure which is divided into BBU and RRU. BBU performs base band processing, transmission, and control, while RRU performs the RF processing.

Figure 1-2 BASE STATION (BBU AND RRU)

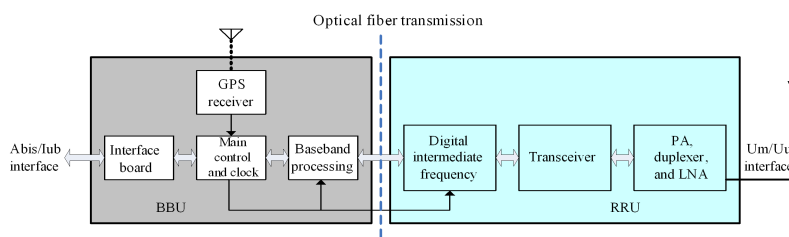

- The base station is divided into BBU and RRU. One BBU provides the base band resource for multiple RRUs
- BBU performs digital base band signal processing and control management.
- RRU performs conversion of the digital base band signal and the analog RF signal between BBU and antenna.
- BBU connects with RRU through the baseband-RF interface (optical interface), and transmits I/Q digital base band signal and OAM signaling data.
- BBU connects with BSC/Node B through Abis/Iub interface.
- RRU realizes MS/UE access through Um/Uu interface.

Distributed Base Station Architecture

BBU and RRU constitute the distributed base station system. One central BBU manages a group of RRUs, realizing rapid and flexible configuration and networking for the base station system. The BBU+RRU solution is a more flexible mode for base station establishment. It reduces requirements for the equipment room and the feeder cable loss.

BBU is arranged indoors and connected with RRU (usually arranged outdoors) through optical fiber, as shown in Figure 1-3.

Figure 1-3 DISTRIBUTED BASE STATION SYSTEM STRUCTURE

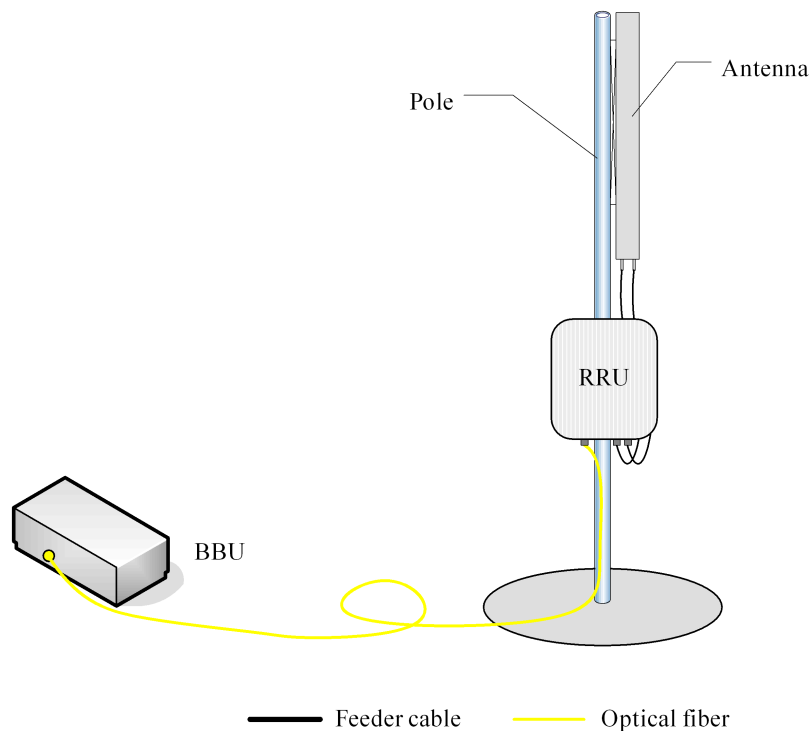

1.3 System Running Environment

The running environment of R8860E GU858 is shown in Figure 1-4.

Figure 1-4 RUNNING ENVIRONMENT OF R8860E GU858

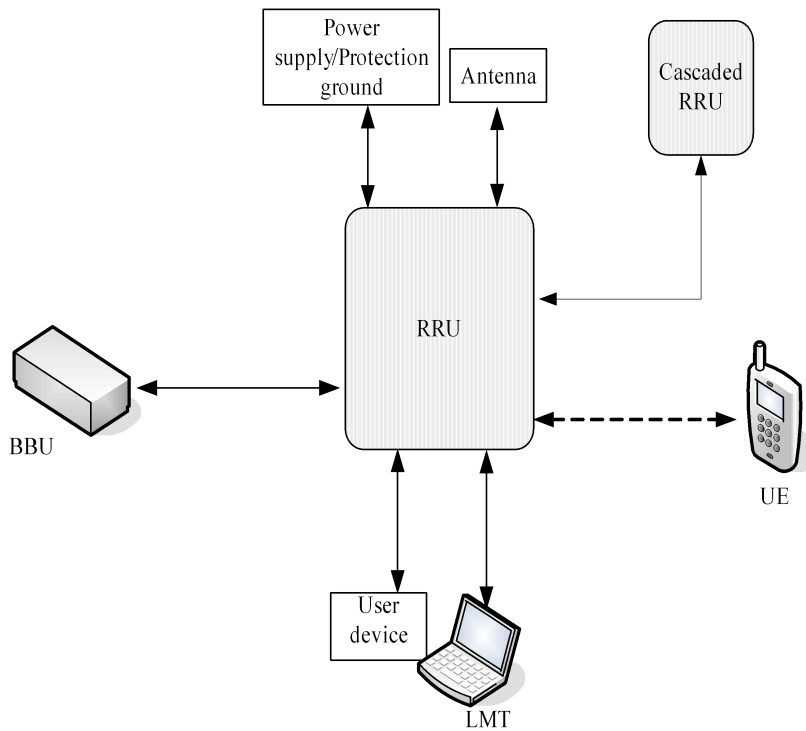

Equipment functions and interfaces related to the running of R8860E GU858 are shown in Table 1-1.

Table 1-1 EQUIPMENTS RELATED TO R8860E GU858 RUNNING

External System	Interface	External System Function Description
MS/UE	Um/Uu interface	Subscriber terminal equipment, realizing voice and data service transmission through the radio interface.
BBU	Baseband-RF interface (optical interface)	Base band resource pool, realizing GPS synchronization, main control, and baseband processing.
Cascaded RRU		Realizing RF processing function
User device	External device interface	Environment monitoring devices, etc.
Antenna	Antenna feeder interface	Receiving and sending radio signals
LMT	LMT interface	Local O & Mterminal

External System	Interface	External System Function Description
Power supply	Power supply interface	Providing power for RRU system
Protection ground	Protection ground interface	System grounding protection
Electrical antenna	Electrical antenna interface0	Antennas with adjustable electrical antenna

1.4 RRU Appearance

Figure 1-5 shows the appearance of the R8860E GU858 chassis.

Figure 1-5 R8860E GU858 Appearance



1.5 System Features

R8860E GU858 has the following system features:

- Dual-mode function

R8860E GU858 supports two radio access modes: GSM and UMTS. it is a dual-mode RRU.

- Distributed architecture

BBU and RRU constitute the distributed base station system, providing a more flexible mode for base station establishment.

- Smooth evolution

→ Smooth evolution towards enhanced **EDGE** and **HSPA+** can be realized through software upgrade, which helps save investment for operators to the maximum extent.

→ R8860E GU858 supports the 25 MHz bandwidth, which enables it to smoothly evolve into **LTE**.

- Flexible configuration and networking

→ With the multi-carrier technology, when R8860E GU858 works in the GSM mode, it supports 1 ~ 6 carriers through modifying software configuration.

→ When R8860E GU858 works in the UMTS mode, R8860E GU858 supports 4 Carrier and Sector (CS).

→ Within the same frequency band, R8860E GU858 can work in GSM/UMTS dual mode through modifying software configuration. For example, it can support the capacity of 4 GSM carriers plus one UMTS CS.

→ Star network, chaining networking, and ring networking at baseband-RF interface are supported.

- Energy saving and environment protection

→ R8860E GU858 adopts the multi-carrier Power Amplification (**PA**) and advanced Doherty and **DPD** linear PA technology.

→ The typical power consumption of R8860E GU858 is less than 215 W.

- Easy installation

R8860E GU858 system has small size and light weight, which facilitates installation and maintenance.

1.6 Services and Functions

R8860E GU858 works with BBU to form the distributed base station system. Signals are transferred to BBU through R8860E GU858 for further processing. R8860E GU858 connects with the baseband processing unit and realizes the following services and functions.

Services

R8860E GU858 provides the following services:

- GSM/EDGE

- Full-rate voice service
- Enhanced full-rate voice service
- Half-rate voice service
- Adaptive multi-rate voice service
- 9.6 Kbps CS-domain data service
- GPRS/EDGE service
- Location service
R8860E GU858 supports Cell ID, Cell ID+RTT, and AGPS location services.
- R99 service
 - CS domain service: adaptive multi-rate voice service (8 coding schemes), CS 64 Kbps data service.
 - PS domain service: UL/DL 64 Kbps, UL/DL 128 Kbps, and UL/DL 384 Kbps data services.
 - Concurrent service: CS domain (AMR 12.2 Kbps, CS 64 Kbps) + PS domain (64 Kbps, 128 Kbps, 384 Kbps).
- HSDPA service
 - 14.4 Mbps data rate
 - 15 code channel
 - HSDPA and R99 can be configured at different carriers
 - Supporting co-frequency/hetero-frequency handover and HSDPA/R99 handover
 - Supporting concurrent service
 - Supporting stream media service
- HSUPA service
5.76 Mbps data rate
- MBMS service
 - Supporting broadcasting and multicasting functions, supporting PtP and Ptm multicast mode
 - Supporting mobility management
 - Supporting stream-type and background-type MBMS service
- HSPA+ service
 - Downlink 43.2 Mbps data rate
 - Uplink 11.5 Mbps data rate

Functions

R8860E GU858 performs the following functions:

- Performs terminal access and RF link transmission function through Um/Uu interface, including RF signal processing, channel coding and decoding, channel multiplexing and de-multiplexing, measurement and report, power control, transmission diversity, reception diversity, calibration, and synchronization.
- Connects with BBU through the optical interface. Functions performed by the optical interface include IQ data transmission, reporting measurement information, RF function configuration, and clock synchronization.
- Provides system management functions through the O&M interface, including configuration management, alarm management, and status check and monitoring.
- Other basic functions
 - Supports GSM Phase I/Phase II/Phase II+
 - Supports UMTS R99, R4, R5, R6, R7
 - Supports EGSM/GSM 800 MHz, UMTS 800 MHz.
 - Supports GPRS CS1~CS4 and EDGE MCS1~MCS9 coding schemes
 - Supports various diversity modes, including space diversity, frequency diversity, time diversity, and polarization diversity
 - Supports Viterbi demodulation algorithm at the receiving end to enhance system receiving sensitivity and channel decoding capability
 - Supports frequency hopping technology
 - Supports inconsecutive transmission technology
 - Supports TA calculation and ultra-distance coverage, with the maximum coverage distance of 120 km
 - Supports Co-BCCH technology

1.7 System Operation and Maintenance

There are two Operation and Maintenance (O & M) modes for R8860E GU858: local O & M and remote O & M. Local O & M uses the LMT software, and remote O & M uses the ZTE NetNumen™ network management system, as shown in [Figure 1-6](#).

Figure 1-6 OPERATION AND MAINTENANCE OF R8860E GU858

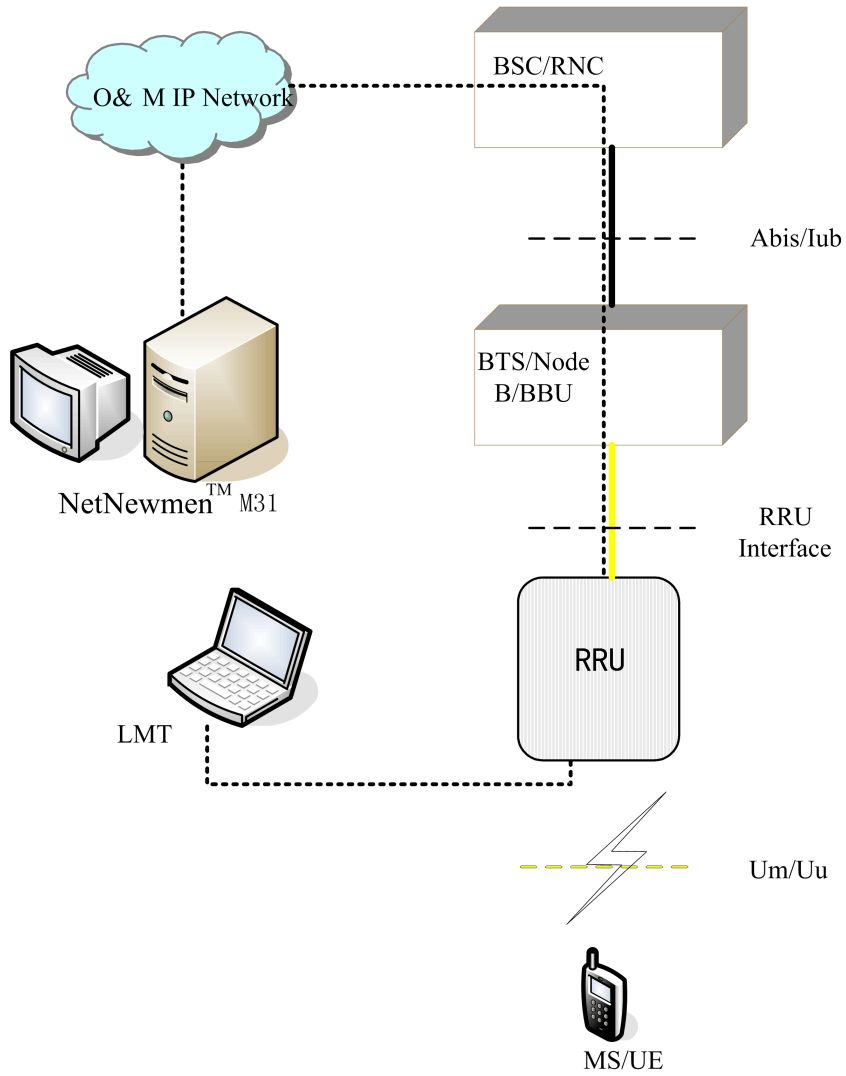

This page intentionally left blank.

Chapter 2

Technical Indices

Table of Contents

Physical Indices	2-1
Radio Performance Indices	2-2
Interface and Transmission Indices	2-3

2.1 Physical Indices

The following lists physical indices of R8860E GU858.

Appearance

Item	Index
Size	370 mm × 320 mm × 197 mm (H × W × D)
Weight	≤ 20 kg
Color	Silver gray

Power Supply and Power Consumption

Item	Index
Peak power consumption	330 W
Rated input voltage	-48 V (-57 V DC ~ -37 V DC)

Environment Condition

Item	Index
Working environment temperature	-40 °C ~ 55 °C
Relative working environment humidity	5% ~ 100%
Storage environment temperature	-45 °C ~ 70 °C
Relative storage environment humidity	5 % ~ 98 %
Transportation condition	With the condition of 4K2/4Z5/4Z7/4B1/4C2/4S3/4 M3, the transportation process lasts less than 180 days.

Reliability

Item	Index
Availability	99.999868%
MTBF	≥ 380,000 hours
MTTR	1 hour
System service interruption time	The system's entire service interruption time ≤ 1.383 minute/year

Wind Load Indices of R8860E GU858

Wind Speed	Frontal	Lateral	Rearside
150 km/h	439 N	219 N	439 N
240 km/h	1137 N	567 N	1137 N

Wind Load Indices of R8860E GU858 Lightning Protection Box

Table 2-1 Wind Speed @ 150 km/h

Lightning Protection Box (H × W × D)	Frontal	Lateral	Rearside
OLP48-2A 295 mm × 220 mm × 86 mm	178 N	70 N	178 N
ZXB08.002 300 mm × 250 mm × 115 mm	206 N	95 N	206 N

Table 2-2 Wind Speed @ 240 km/h

Lightning Protection Box (H × W × D)	Frontal	Lateral	Rearside
OLP48-2A 295 mm × 220 mm × 86 mm	462 N	180 N	462 N
ZXB08.002 300 mm × 250 mm × 115 mm	534 N	245 N	534 N

2.2 Radio Performance Indices

The following lists radio performance indices.

Capacity Indices

Item	Index
Single-mode configuration	GSM 6 TRX or UMTS 4 Carriers
G/U dual-mode configuration	4 GSM TRX and 1 UMTS carriers or 2 GSM TRX and 2 UMTS carriers

RF Indices

Item	Index
Working Frequency	GU858 GSM800/UMTS800: Uplink frequency range: 824~849 MHz Downlink frequency range: 869~894 MHz
Maximum transmission power	GSM: GMSK 80 W/8PSK 50 W UMTS: 80 W
Static receiving sensitivity	GSM: -113 dBm@GSM single antenna UMTS: -126.5 dBm@UMTS single antenna/-129.2 dBm@UMTS double antennas

2.3 Interface and Transmission Indices

The following lists interface and transmission indices.

Item	Index
Baseband-RF interface	2, connecting with the baseband unit and cascading with other RRUs.
RS485 interface	1, connecting with external monitoring equipment.
FE interface	1, used for local maintenance.
Antenna port	2, connecting with antenna feeder.
AISG interface	1, used for electrical downtilt adjustable antenna
Dry contact input	4 ways, external alarm

This page intentionally left blank.

Chapter 3

Structure and Principles

Table of Contents

- Structure Layout.....3-1
- Hardware Principle.....3-4
- Software System.....3-7

3.1 Structure Layout

3.1.1 External Interfaces

The external interfaces of R8860E GU858 are located at the bottom of the chassis, as shown in Figure 3-1.

Figure 3-1 External Interfaces at Chassis Bottom

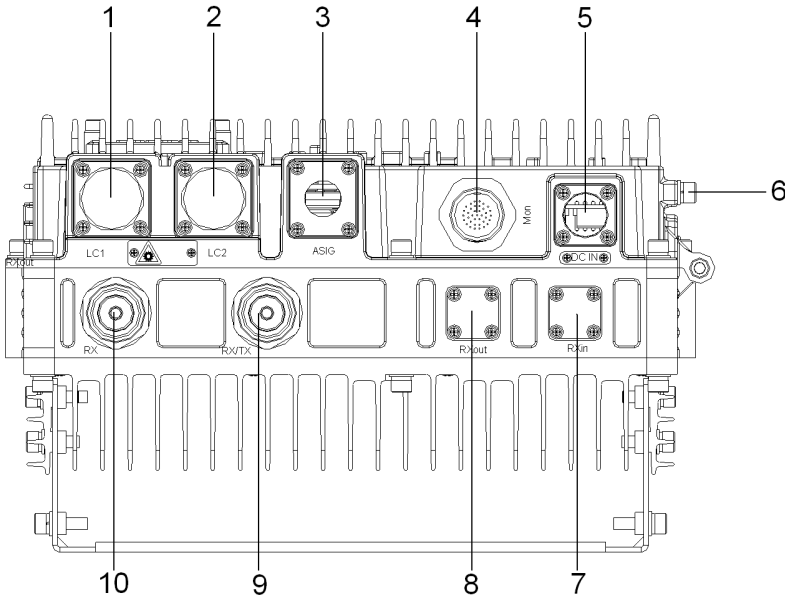

Table 3-1 describes the external interfaces.

Table 3-1 External Interfaces

Serial Number	Label	Interface	Interface Type/Connector
1	LC1	Interface between BBU and RRU/RRU cascading interface	LC-type optical interface (IEC 874)
2	LC2	Interface between BBU and RRU/RRU cascading interface	LC-type optical interface (IEC 874)
3	AISG	AISG equipment interface	8-core aeronautical socket (IEC 60130-9-ED)
4	Mon	External equipment interface (monitoring, LMT, etc.)	37-core aeronautical socket
5	DC IN	Power supply interface	DC interface: Connector XCG18T4K1P1-01+XC18FJJP1-10.5 The cable's cross-sectional area is 1.5 mm ²
6	GND	The equipment is grounded	The cable's cross-sectional area is 35 mm ²
7	RXin	Frequency point extended interface	N-KY (MIL-C-39012 or IEC169-16)
8	RXout	Frequency point extended interface	N-KY (MIL-C-39012 or IEC169-16)
9	RX/TX	Transmitting/Receiving main diversity RF cable interface	50 Ω DIN-type connector
10	RX	Receiving diversity RF cable interface	50 Ω DIN-type connector

3.1.2 Indicators and Buttons

R8860E GU858 indicators and buttons are located in the bottom-left of the front panel of the chassis, behind the cover plate, as shown in [Figure 3-2](#).

Figure 3-2 R8860E GU858 Indicators and Buttons

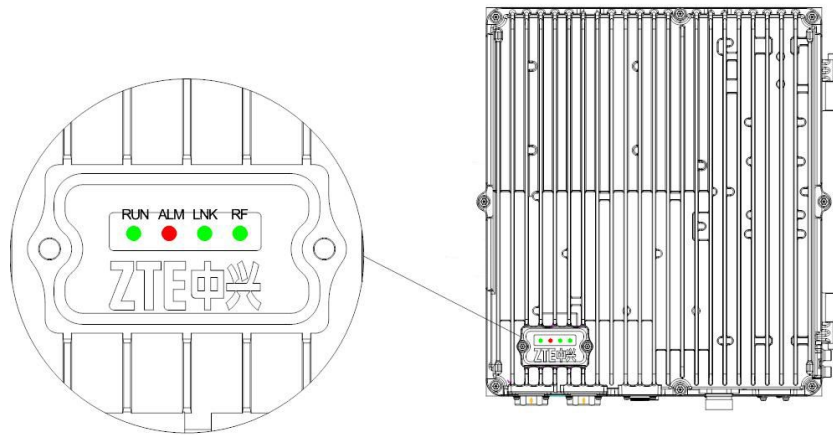

Table 3-2 describes the indicators and buttons.

Table 3-2 Indicators and Buttons

Color	Name	Meaning	Working Mode
Green	RUN	Running indicator	Constantly ON: R8860E GU858 is being reset and started.
			Flashing at 1 Hz: Normal status
			Flashing at 5 Hz: Indicates that version is being downloaded.
			OFF: Indicates the self-test fails.
Red	ALM	Alarm indicator	OFF: Indicates that there is no fault or R8860E GU858 is being reset, started, or downloading version.
			Flashing at 5 Hz: Indicates critical alarm or major alarm.
			Flashing at 1 Hz: Indicates minor alarm or warning.

Color	Name	Meaning	Working Mode
Green	LNK	Optical link indicator	Constantly ON: The optical fiber connection is normal.
			OFF: The optical fiber is disconnected.
			Flashing at 5 Hz: The link is taken as the clock reference source, and Phase-Locked Loop (PLL) is in the capture status.
Green	RF	RF working status indicator	Flashing at 2.5 Hz: The link is taken as the clock reference source, and Phase-Locked Loop (PLL) is in the tracing status.
			OFF: There is no RF output.
			ON: There is RF output.

3.2 Hardware Principle

3.2.1 Hardware Architecture

For general hardware architecture block, see [Figure 3-3](#)

Figure 3-3 HARDWARE SYSTEM

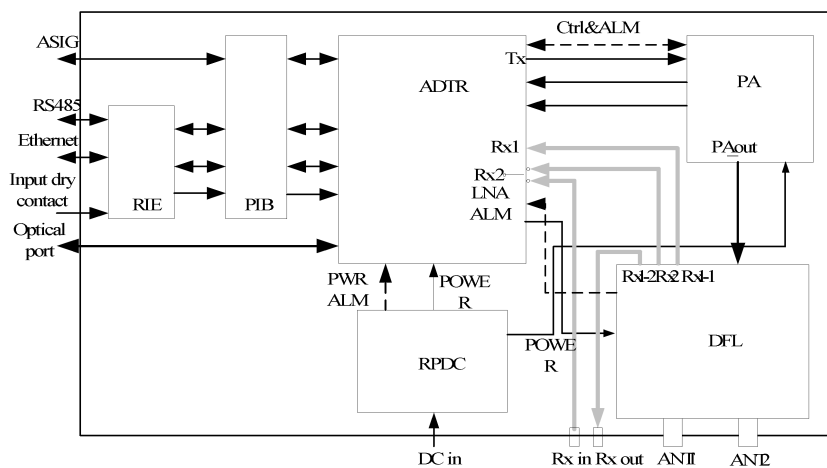

R8860E GU858 is composed of ADTR, PA, DFL, RIE, PIB, and RPDC, as shown in [Table 3-3](#).

Table 3-3 COMPOSITION OF M8206 CABINET HARDWARE

Name	Meaning	Main functions
ADTR	Advanced Dual-mode transceiver board	Completes the function of transmitter by one path and receiver by two paths, providing interface and control
PA	RRU Power Amplify Unit	Provides amplification function during transmission for RF signal
DFL	Duplexer filter line	Provides receiving & transmitting combination and division function for RF signal, and provides low noise amplification function for signal. It includes duplexer by one path and receiving filter by one path.
RIE	RRU interface exchange board	Mainly completes the transition between PIB board test and monitoring interface signal
PIB	Protective interface board	Mainly completes electrically tuned antenna and tower amplifier AISG interface protection and ADTR board interface signal transition
RPDC	RRU Power Module	Supplied by DC power conversion

3.2.2 Board Functions

1. ADTR

- Process 2 paths receiving and 1 path transmitting signal;
- Uplink & downlink transition for radio link signal;
- Downlink IQ signal multiplexing, uplink IQ signal demultiplexing;
- Signal amplification, filter, and digit/analog conversion;
- Optical and electric signal conversion;
- Extract clock reference signal from baseband unit, provide clock for different modules;
- RTWP and TSSI measurement report;
- Standing wave ratio (SWR) measurement report
- Hardware failure self-test and alarm;
- Environment Detection;
- Provide 2 paths of baseband–RF interface and 4 paths of external alarm input, and a serial port, a FE interface, a RS232 interface, and a AISG interface;
- Provide reset function.

2. PA

Amplify downlink RF signal input by ADTR, and output it to DFL;

Provide digital predistortion feedback signal for ADTR;

Provide power amplification output control;

Feedback forward power coupling signal to ADTR, and ADTR do forward power inspection;

Feedback backward power coupling signal to ADTR, and ADTR do backward power (SWR) inspection;

Provide PA internal temperature data to ADTR and ADTR will do temperature inspection.

3. DFL

Combination and separation of receiving and transmitting signal;

Filter function of receiving & transmitting signal;

Low-noise amplification function;

Provide DFL alarm inspection function.

4. RIE

Access following these signals from PIB board: Ethernet signal, 485 dry contact, LED indicator, single board reset signal, jumper, button signal, digital ground;

Transmit the access signal by the socket and finish the function of interface conversion.

5. PIB

Access following these signals from ADTR board: Ethernet signal, LED indicator, single board reset signal, jumper, button signal, digital ground, power, ground and 458 signal of electrically tuned antenna;

Power, ground, and 458 signal of electrically tuned antenna, output to electrically tuned antenna by socket; other signals are introduced to outside by test socket, to do debug and use as indicative signal;

Finish AISG interface power filtering and 485 lightning protection;

Finish interference protection for indicators, reset signals, buttons, and jumpers.

6. RPDC

Finish power conversion from DC to DC, and provide power supply function;

Inspect input overvoltage or undervoltage, input power disconnection, output overvoltage or undervoltage, output over-current alarm, and report it to ADTR board.

3.3 Software System

3.3.1 Software Architecture

R8860E GU858 software can be classified into drivers, supporting software, and application software, as shown in Figure 3-4.

Figure 3-4 R8860E GU858 SOFTWARE ARCHITECTURE

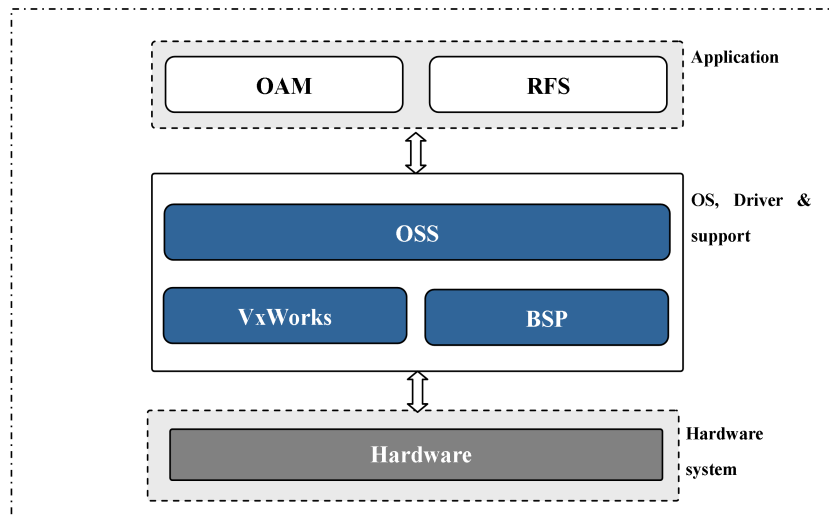

3.3.2 Software Functions

Application layer includes radio frequency subsystem (RFS) and operation and maintenance (OAM) subsystem, mainly implementing software download, configuration, management, system maintenance, and measurement.

Operation Support Sub-system (OSS) is the supporting layer of whole software framework, which provides a hardware-unrelated platform to run system software and provides basic software function, such as dispatching, timer, memory management, inter-module communication, sequence control, monitoring, alarm, and log function.

Board Support Package (BSP) is responsible for routing relevant information and data to application layer of GSM or UMTS.

VxWorks is the operating system of hardware platform.

This page intentionally left blank.

Chapter 4

Installation

Table of Contents

Safety Description	4-1
Preparation	4-7
Unpacking and Checking.....	4-15
Installation Overview	4-17
Cabinet Installation.....	4-20
External Cable Installation.....	4-46
Hardware Installation Inspection.....	4-57
Power on and off	4-61

4.1 Safety Description

4.1.1 Safety Specifications Guide

These safety instructions must be considered as supplementary for local safety regulations. The priority must be given to local safety regulations if there is any conflict between the two.

The maintenance personnel must have the knowledge of safety operations and maintenance with required qualification and technical background.



Warning

This device complies with part 15 of the FCC Rules. Operation is subject to the following two conditions: (1) This device may not cause harmful interference, and (2) this device must accept any interference received, including interference that may cause undesired operation. Changes or modifications not expressly approved by the party responsible for compliance could void the user's authority to operate the equipment.

All the operation and maintenance personnel must follow the safety precautions and instructions provided by ZTE Corporation to avoid any accident.



Note

ZTE Corporation does not bear any liabilities incurred because of violation of the universal safety operation requirements, or violation of safety standards for designing, manufacturing and using the equipment.

FCC Radiation Exposure Statement:

This equipment complies with FCC radiation exposure limits set forth for an uncontrolled environment .This equipment should be installed and operated with minimum distance 4 m between the radiator& your body.

FCC & IC Statement



Warning

Changes or modifications to this unit not expressly approved by the party responsible for compliance could void the user’s authority to operate the equipment.



Note

This equipment has been tested and found to comply with the limits for a Class A digital device, pursuant to Part 15 of the FCC Rules. These limits are designed to provide reasonable protection against harmful interference when the equipment is operated in a commercial environment. This equipment generates, uses, and can radiate radio frequency energy and, if not installed and used in accordance with the instruction manual, may cause harmful interference to radio communications. Operation of this equipment in a residential area is likely to cause harmful interference in which case the user will be required to correct the interference at his own expense.









Operation of this equipment in a residential area is likely to cause harmful interference in which case the user will be required to correct the interference at his own expense.

4.1.2 Safety Symbols

Table 4-1 lists safety symbols. They are to prompt the user of the safety precautions to be observed during R8860E GU858 operation and maintenance.

Table 4-1 Safety Symbols Description

Safety Symbols	Meaning
	No smoking: Smoking is forbidden

Safety Symbols	Meaning
	No flammables: No flammables can be stored.
	No touching: Do not touch.
	Universal alerting symbol: General safety attentions.
	Electric shock: Risk of electric shock.
	Electrostatic: The device may be sensitive to static electricity.
	Microwave: Beware of strong electromagnetic field.
	Laser: Beware of strong laser beam.
	Scald: Beware of scald.

Amongst these safety symbols, the universal alarm symbols are classified into three levels: danger, warning, and caution. The formats and meanings of the three levels are described as below:



Danger

Indicates a potentially hazardous situation which, if not avoided, will result in death or serious injury of people, or equipment damages and breakdown.



Warning

Indicates a potentially hazardous situation which, if not avoided, could result in death or serious injury.



Caution

Indicates a potentially hazardous situation which, if not avoided, could result in serious injuries, equipment damages or interruption of part services.

4.1.3 Safety Instructions

This section describes the safety instructions related to electrical safety, antistatic, heavy objects and modules.

Electrical Safety Instructions

The following are the electrical safety instructions about tools, high voltage, power cables, holes and lightning:

- **Tools**

Use special tools rather than common tools for high-voltage and AC operations.

- **High Voltage**



Danger

High voltage is hazardous. Direct or indirect contact with high voltage or main supply using a wet object could result in death.

-
- Strictly follow local safety rules to install AC power devices.
 - Installation staff must be qualified for performing high-voltage and AC operations.
 - Do not wear any watch, hand chain, bracelet, ring or any other conductive objects during such operations.
 - Prevent moisture from accumulating on the equipment during operations in a damp environment.

- **Power Cable**



Warning

Never install or uninstall power cables while they are live. Otherwise, the power cable, when contacting a conductor, may result in sparks or electric arc causing a fire or even damage to eyes.

-
- Make sure of shutting off power supply before installing or disconnecting a power cable.
 - Before connecting the power cable, make sure that the connecting cable and its label are appropriate for the actual installation requirements.

- **Drilling Holes**



Warning

It is not allowed to drill chassis holes without permission.

-
- Unqualified drilling could damage wiring and cables inside the chassis. Additionally, metal pieces inside the chassis created by the drilling could result in a short circuit. Use insulation protection gloves and first move cables inside a chassis away when drilling is necessary on a chassis.

- Protect eyes during drilling as dust or flying debris may damage eyes.
- Clean any debris in time after drilling.

- **Lightning**

**Danger**

Do not perform high-voltage, AC, iron tower or mast operations in a thunderstorm.

Thunderstorms would give rise to a strong electromagnetic field in the atmosphere. Therefore, the equipment must be grounded and protected in time against lightning strikes.

Antistatic Safety Instructions

**Electrostatic**

Static electricity produced by human body can damage static-sensitive components on circuit board, such as large-scale integrated circuits.

- Friction caused by human body activities is the root cause of electrostatic charge accumulation. Static voltage carried by a human body in a dry environment can be up to 30 kV, and can remain there for a long time. An operator with static electricity may discharge electricity through a component when he/she touches the conductor and causing damage.
- Wear an antistatic wrist strap (the other end of wrist strap must be well grounded) before touching the equipment or holding a plug-in board, circuit board, Integrated Circuit (IC) chip or other devices, to prevent human static electricity from damaging sensitive components.
- The antistatic wrist strap used must be subject to regular check. Do not replace the cable of an antistatic wrist strap with any other cables.
- Do not contact static-sensitive modules with any object that easily generates static electricity. For example, friction of package bag, transfer box and transfer belt made from insulation plastic may cause static electricity on components. Discharge of static electricity may damage components when they contact a human body or the ground.
- Modules should only contact materials such as an antistatic bag. Keep modules in antistatic bags during storage and transportation.
- Discharge static electricity of the test device before use, that is, ground the test device first.
- Do not place the module near a strong DC magnetic field, such as the cathode-ray tube of a monitor. Keep the module at least 10 cm away.

Hoisting Heavy Objects



When hoisting heavy objects, ensure that nobody is standing or walking under the hoisted object.

- Ensure the hoister can meet hoisting requirements when disassembling heavy equipment, or moving and replacing equipment.
- The installation personnel must be duly trained and qualified for hoisting operations.
- Hoisting tools must be inspected and complete before service.
- Make sure that hoisting tools are fixed firmly on a sufficiently secured object or wall before the hoisting operation.
- Give brief oral instructions during hoisting operations to prevent any mishap.

Unplugging/Plugging a Module

- Never plug a module with excessive force, to ensure that the pins on the backplane do not get deformed.
- Plug the module right into the slot and make sure module circuit faces do not contact each other lest any short circuit may occur.
- Keep hands off the module circuit, components, connectors and cable trough when holding a module.

Rack Mount Safety Instructions

Rack Mount Instructions - The following or similar rack-mount instructions are included with the installation instructions:

- Elevated Operating Ambient - If installed in a closed or multi-unit rack assembly, the operating ambient temperature of the rack environment may be greater than room ambient. Therefore, consideration should be given to installing the equipment in an environment compatible with the maximum ambient temperature (T_{ma}) specified by the manufacturer.
- Reduced Air Flow - Installation of the equipment in a rack should be such that the amount of air flow required for safe operation of the equipment is not compromised.
- Mechanical Loading - Mounting of the equipment in the rack should be such that a hazardous condition is not achieved due to uneven mechanical loading.
- Circuit Overloading - Consideration should be given to the connection of the equipment to the supply circuit and the effect that overloading of the circuits might have on overcurrent protection and supply wiring. Appropriate consideration of equipment nameplate ratings should be used when addressing this concern.
- Reliable Earthing - Reliable earthing of rack-mounted equipment should be maintained. Particular attention should be given to supply connections other than direct connections to the branch circuit (e.g. use of power strips).

Other Safety Instructions



Note

Do not perform maintenance or debugging independently, unless a qualified person is present.

- Perform an airtight test before RRU delivery, and prohibit disassembling the RRU on site.
- Replacing any parts or making any changes to the equipment might result in an unexpected danger. Therefore, be sure not to replace any parts or perform any changes to the equipment unless authorized otherwise.
- Due to that RRU is in high temperature during running, the RRU should be installed in some regions out of operators' reach or strictly restricted.
- Contact ZTE office if you have any question, to ensure your safety.

4.2 Preparation

R8860E GU858 is the outdoor dual-mode RF remote unit in the ZTE ZXSDR series base station products.

ZTE Corporation has launched a series of base station products to satisfy various requirements of operators. One of the solutions is dividing the base station into two parts: Base Band Unit (BBU) and Remote Radio Unit (RRU). R8860E GU858 is the outdoor RRU, and it works with BBU to realize complete logical functions of a base station.

R8860E GU858 adopts the multi-carrier technology as its core technology. It supports two radio systems: GSM and UMTS. R8860E GU858 can be used as an independent RRU for GSM or an independent RRU for UMTS, and it works with BBU to form the dual-mode base station.

4.2.1 Engineering Condition Inspection

Before installing devices, follow the requirements of *Environment Acceptance Report* and check installation environment. The following content is just as a reference.

Installation Position Inspection

R8860E GU858 installation position should accord with the requirements of engineering design, the specified requirements as follows:

- Avoid dusty, harmful-gas or explosive-goods environment;
- Avoid the places with big shock or strong noise;
- Far away substation;
- Far away pollution source;
- Avoid an industrial boiler and heating boiler;
- Far away high-power wireless interference source.

Temperature and Humidity Inspection

R8860E GU858 temperature and humidity in work environment should meet the requirements, as shown in

Power Supply Inspection

The requirements of R8860E GU858 power supply are described as follows.

1. DC power supply: R8860E GU858 is -48 V DC power supply and the voltage of power supply is $-40\text{ V DC}\sim-57\text{ V DC}$.
2. Indirect AC power supply: adopt an outdoor AC unit (OAU); the OAU can provide 220V AC power supply for one ZXSDR B8200 C100 and one R8860E GU858 at the same time.

Lightning Inspection

The R8860E GU858 lightning requirements are described as follows.

- Outdoor Installation
 1. For DC power supply, configure an outdoor DC lightning box OLP48-2. If the DC power is exported from the equipment room, the length of power cable is more than 10 m (less than 50 m) and the output end of indoor DC power is not configured with B-level or above lightning devices, it is required to configure an indoor DC lightning box ILP48-3 in the equipment room.
 2. For indirect AC power supply, it is required to configure an AC lightning box (ZXPCS combined arrester).
- For indoor installation, if the power cable is distributed outdoors, configure the power lightning box according to the conditions of outdoor installation.

Grounding Inspection

R8860E GU858 adopts an associated grounding mode. The value of grounding resistance is not more than 5 ohm.

Other Inspections

1. The corollary devices or components should accord with the requirements of R8860E GU858 engineering design drawing.
2. The transmission devices interconnected with BBU should have been prepared.

4.2.2 Requirements to Onsite Personnel

The onsite engineering supervisor is in charge of the training and management of installation personnel, to make sure the installation is performed correctly and control installation quality. The installation personnel perform the installation. Refer to Safety Instruction.

Requirements to Engineering Supervisor

- The engineering supervisor should have quality control ability.

- The engineering supervisor should have received corresponding ZTE training and obtained certification.
- The engineering supervisor should be familiar with the materials, tools and operation methods used in the installation.
- The engineering supervisor should be familiar with the installation flow and installation methods of each component.
- The engineering supervisor should follow the “Safety First” principle, to ensure the smooth completion of installation.

Requirements to Installation Personnel

- The installation personnel should have received corresponding ZTE training and obtained certification.
- The installation personnel should be healthy, have not drunk alcohol.
- The installation personnel should follow the safety instructions of tools, and use safety belts.
- The installation personnel should fasten the tools, to prevent them from falling.
- The installation personnel should not wear loose clothes and slippery shoes.

4.2.3 Technical Document Preparation

Before installing R8860E GU858, make sure that the following technical document is at hand:



- ZXSDR R8860E GU858 GU858 Outdoor GSM&UMTS Dual Mode Macro RRU User Manual











4.2.4 Tools and Instruments Preparation







Table 4-2 shows tools and meters list required during installation.











Table 4-2 Tool and Meter List







Category	Name	Example
Special-purpose tools	One feeder connector knife	
	One 75 Ω coaxial cable stripper	



Category	Name	Example
	One multi-functional crimping pliers	
	One multimeter	
	One standing wave ratio tester	
	One earth resistance tester	
Punching tools	One electric percussion drill	
	Several auxiliary percussion drill bits	
	One vacuum cleaner	
	Power connector board (providing at least 3 two-phase sockets and 3 three-phase sockets, with the current capacity larger than 15 A)	

Category	Name	Example
General-purpose tools	Cross screwdrivers (4", 6" and 8" each)	
	Flathead screwdrivers (4", 6" and 8" each)	
	Adjustable wrenches (6", 8", 10" and 12" each)	
	Dual-purpose wrenches (17" and 19" each)	
	One set of socket wrenches	
	One paper knife	
	5 kg nail hammer	
	One 300 W iron and one 40 W iron	
	One set of inner-hexagon wrench	
Solder wires		

Category	Name	Example
Measurement tools	One 50 m (164 feet) tape measure	
	One 5 m (16 feet) steel tape	
	One angle instrument	
	One compass	
	One level bar	
	One plumb	
Protection tools	Antistatic wrist strap	

Category	Name	Example
	slip-proof gloves	
	Safety helmet	
Clamp tools	One hacksaw (with several saw blades)	
	One pair of sharp-nose pliers (8")	
	One pair of diagonal pliers (8")	
	One pair of round-nose pliers (8")	
	One pair of vices (8")	
	One set of needle files (medium-sized)	
	Nippers	
	One paint brush	
	One pair of scissors	

Cate-gory	Name	Example
	One hot air blower	
	One solder removal tool	
	One hydraulic crimper	
	One crowbar	
Auxiliary tools	Pulley set	
	Rope	
	Ladder	

Category	Name	Example
Meters	Spectrum analyzer (required in certain special cases)	
	BTS tester	
	Field strength tester (required in certain special cases)	

4.3 Unpacking and Checking

4.3.1 Container of R8860E GU858

R8860E GU858 uses cartons for packing. The R8860E GU858 cabinet is wrapped by EPE polyfoam and then put into the carton, as shown in [Figure 4-1](#).

Figure 4-1 PACKING OF R8860E GU858

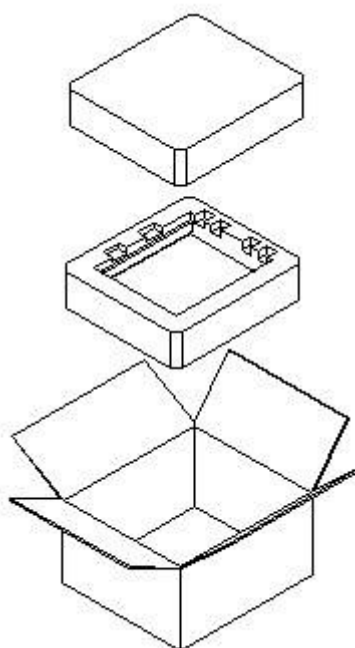

4.3.2 Flow of Unpacking and Checking

The flow of unpacking and checking is shown in Figure 4-2. Refer to the Unpacking and Checking Manual in the R8860E GU858 engineering materials for detailed steps.

Figure 4-2 FLOW OF UNPACKING AND CHECKING

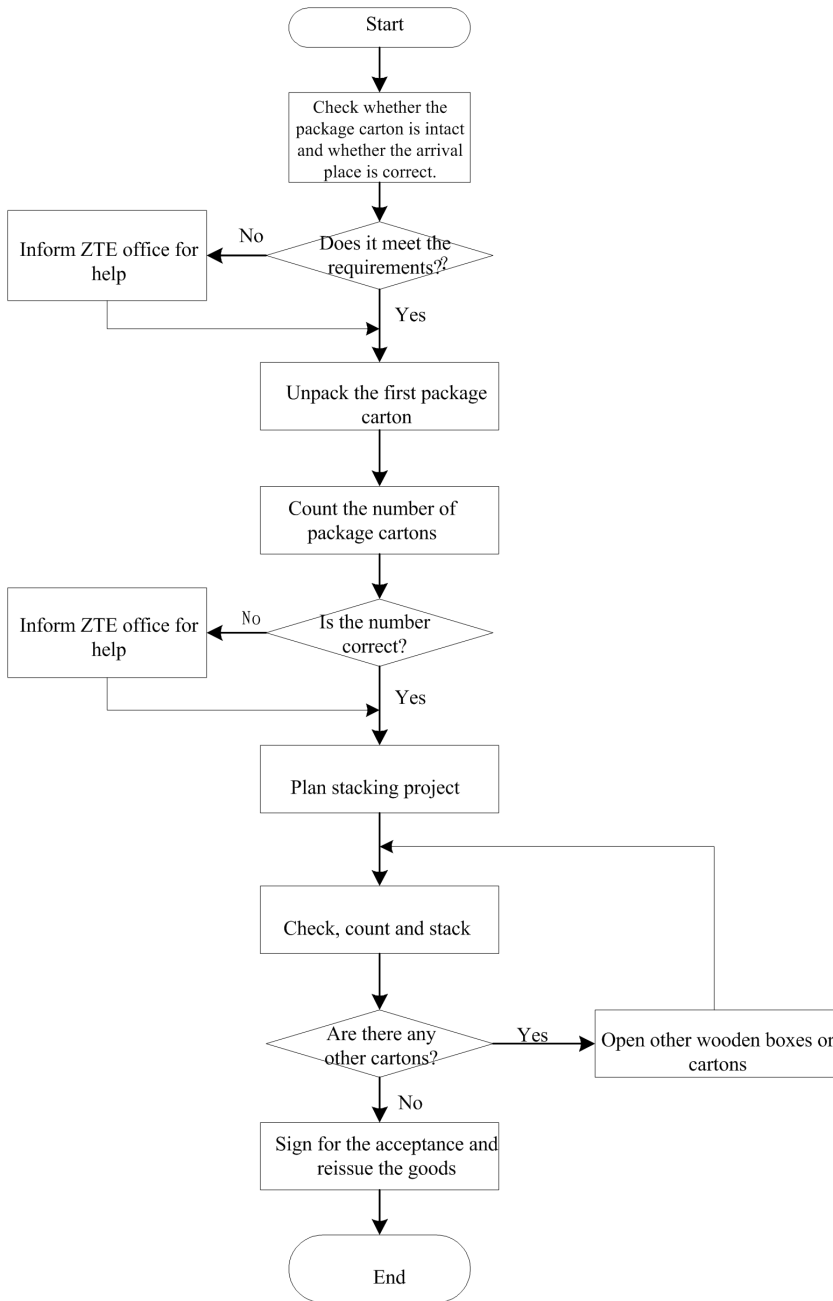

4.4 Installation Overview

4.4.1 Installation Flow

The installation of R8860E GU558 includes two parts, that is, main part installation and cable installation. The installation flow is shown in [Figure 4-3](#)

Figure 4-3 R8860E GU558 Installation Flow

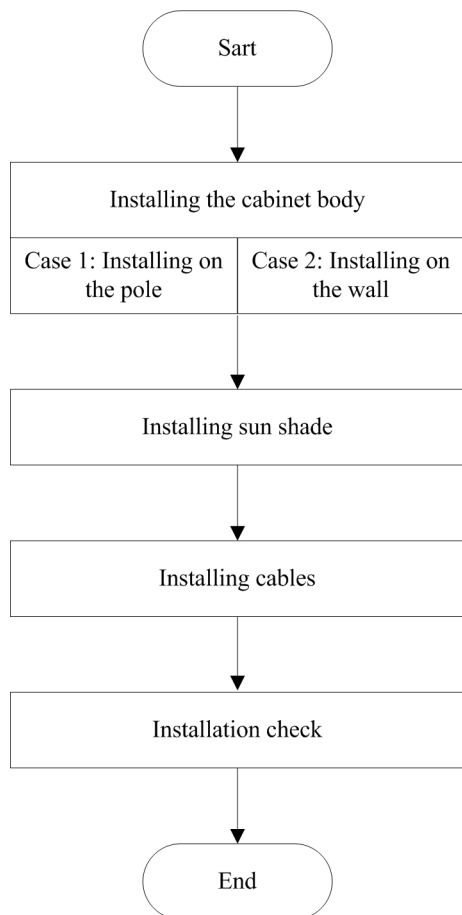

4.4.2 Hoisting Operation Instructions

If it is required to hoist RRU to the tower, refer to the following instructions.

Prerequisites

- Natural conditions for hoisting operation are satisfied, such as no fog and high visibility. The hoisting operation is prohibited in windy, snowy, or rainy days.
- Tools for hoisting operation are available, such as the hoisting rope (with a bearing capacity of 100 kg) and the crown block, and the crown block is firmly installed in appropriate position on the tower.
- Open the package to check whether the cabinet is in good condition. Hoist the cabinet to the tower after the inspection.

Procedure

Perform the following steps for hoisting operation.

1. Take out the cabinet, make its fixing board upwards, and lay it on the floor, as shown in [Figure 4-4](#).

Figure 4-4 Taking out Cabinet



2. Bind the fixing board with rope, as shown in [Figure 4-5](#). Make sure that the rope is bound on the two fixing boards, and the binding is firm.

Figure 4-5 Binding Cabinet with Rope



3. When performing the hoisting operation, two persons stand at the foot of the tower. One pulls the rope slowly, the other one releases the rope slowly and prevents the cabinet from touching the tower, protecting the heat sink device and the cabinet, as shown in [Figure 4-6](#).

Figure 4-6 Hoisting Operation Schematic Diagram

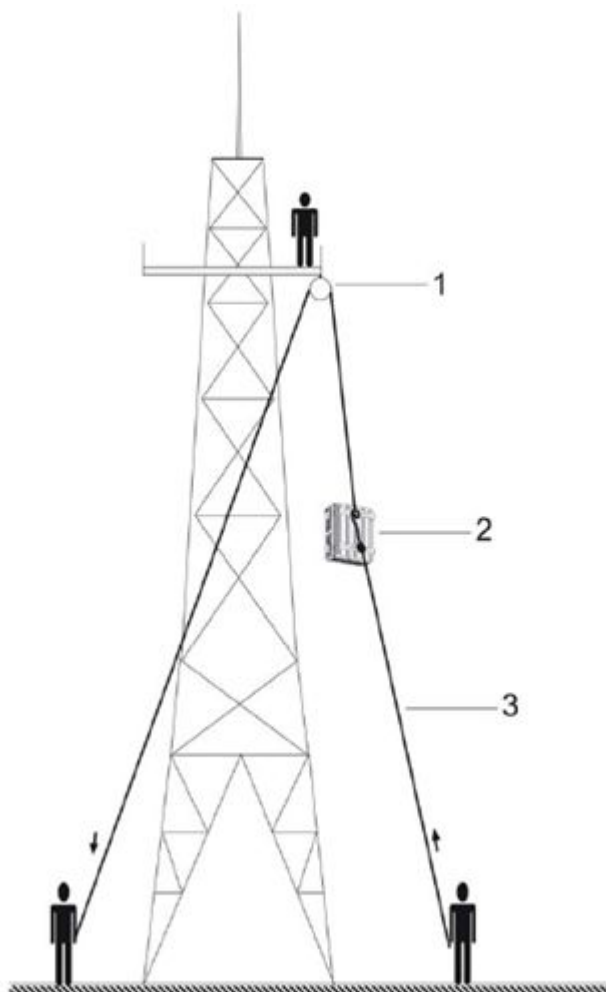

 **Warning**

- The RRU handle can not be used for binding the hoisting rope.
- It is strictly prohibited to use steel wire rope as the hoisting rope.
- During the hoisting procedure, irrelevant person is prohibited to stand surrounding the tower, especially under the RRU, to avoid unexpected injury.

4.5 Cabinet Installation

4.5.1 Installation Mode Instruction

According to different installation environments, there are three modes of R8860E GU858 installation:

- Pole-mount installation
- Wall-mount installation

- Gantry-mount installation
- Simplified-cabinet integrative Installation

4.5.2 Installation Methods and Accessories

There are two installation methods for R8860E GU858, as below:

- Pole mounted installation (Pole Mounting Kit): It is suggested that the diameter of installation pole should be 60 mm ~ 120 mm.
- Pole mounted installation (Universal Sheet-Metal Kit): It is suggested that the diameter of installation pole should be 60 mm ~ 114 mm.
- Wall mounted installation.



Note

The universal sheet-metal kit also support channel iron and angle iron. The supported channel width is 50mm–100mm. The supported angle iron width is 63mm-80mm. (The installation method is similar to the pole installation.)

4.5.2.1 Installation Accessories

The installation accessories of R8860E GU858 and their functions are shown in [Table 4-3](#).

Table 4-3 INSTALLATION ACCESSORIES OF R8860E GU858 AND THEIR FUNCTIONS

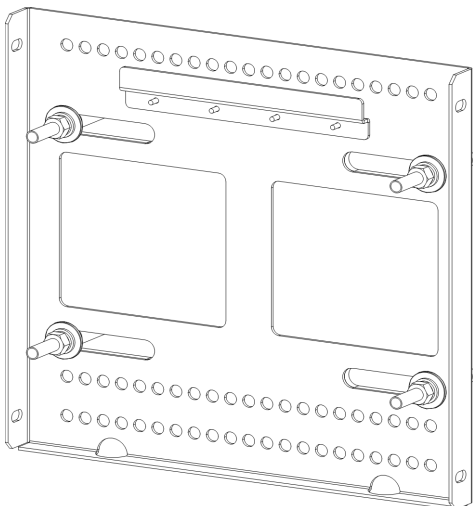
Name	Shape	Function
Wall mounted installation assembly		Used by wall mounted and pole mounted installation (clamp assembly for pole mounted installation)