



ZXSDR R8882

Macro Remote Radio Unit

Product Description

Hardware Version: HV2.0

ZTE CORPORATION
NO. 55, Hi-tech Road South, ShenZhen, P.R.China
Postcode: 518057
Tel: +86-755-26771900
Fax: +86-755-26770801
URL: <http://ensupport.zte.com.cn>
E-mail: support@zte.com.cn

LEGAL INFORMATION

Copyright © 2011 ZTE CORPORATION.

The contents of this document are protected by copyright laws and international treaties. Any reproduction or distribution of this document or any portion of this document, in any form by any means, without the prior written consent of ZTE CORPORATION is prohibited. Additionally, the contents of this document are protected by contractual confidentiality obligations.

All company, brand and product names are trade or service marks, or registered trade or service marks, of ZTE CORPORATION or of their respective owners.

This document is provided “as is”, and all express, implied, or statutory warranties, representations or conditions are disclaimed, including without limitation any implied warranty of merchantability, fitness for a particular purpose, title or non-infringement. ZTE CORPORATION and its licensors shall not be liable for damages resulting from the use of or reliance on the information contained herein.

ZTE CORPORATION or its licensors may have current or pending intellectual property rights or applications covering the subject matter of this document. Except as expressly provided in any written license between ZTE CORPORATION and its licensee, the user of this document shall not acquire any license to the subject matter herein.

ZTE CORPORATION reserves the right to upgrade or make technical change to this product without further notice. Users may visit ZTE technical support website <http://ensupport.zte.com.cn> to inquire related information.

The ultimate right to interpret this product resides in ZTE CORPORATION.

Revision History

Serial No.	Publishing Date	Publishing Reason
R1.1	2011-12-30	Modified the following sections: <ul style="list-style-type: none">● 1.3 Services and Functions● 1.4 Product Specifications● 2.1.1 Hardware Architecture
R1.0	2011-10-30	First Edition

Serial Number: SJ-20111021104623-002

Publishing Date: 2011-12-30 (R1.1)

Contents

About This Manual	I
Chapter 1 Product Overview	1-1
1.1 Position of the ZXSDR R8882 in the Radio Network	1-1
1.2 Product Features.....	1-1
1.3 Services and Functions	1-3
1.4 Product Specifications	1-6
1.5 Installation Scenarios	1-7
Chapter 2 System Structure	2-1
2.1 Hardware Subsystem	2-1
2.1.1 Hardware Architecture	2-1
2.1.2 Module Functions.....	2-2
2.2 Software Subsystem.....	2-3
2.2.1 Software Architecture	2-3
2.2.2 Software Functions.....	2-4
Chapter 3 Operation and Maintenance.....	3-1
3.1 Operation and Maintenance Modes.....	3-1
3.2 Operation and Maintenance Functions.....	3-2
Chapter 4 Networking	4-1
4.1 Star Networking	4-1
4.2 Cascade Networking	4-1
4.3 Ring Networking.....	4-2
Chapter 5 Technical Specifications	5-1
5.1 Physical Specifications	5-1
5.2 Radio Performance	5-2
5.3 Interfaces	5-3
Chapter 6 FCC & IC STATEMENT	6-1
Figures.....	I
Tables	III
Index	V
Glossary	VII

About This Manual

Purpose

The ZXSDR R8882 is a multi-mode remote [RF](#) unit that supports 2T4R [FDD](#). It supports [GSM](#), [UMTS](#), [CDMA](#), and [LTE](#) communications systems and features compact structure, large capacity, and easy installation.

The ZXSDR R8882 works with a [BBU](#) to constitute the distributed [SDR BTS](#), that is, ZXSDR of ZTE.

This manual provides a general description of the ZXSDR R8882, covering the product features, services and functions, system architecture, operation and maintenance, networking, and technical specifications.

Intended Audience

This manual is intended for

- Engineering personnel and technicians
- Installation engineers
- Maintenance engineers

What is in This Manual



This manual contains the following chapters:

Chapter	Summary
Chapter 1, Product Overview	Describes the position of the ZXSDR R8882 in the radio network, product features, services and functions, and installation scenarios.
Chapter 2, System Structure	Describes the hardware and software structures of the ZXSDR R8882 and the functions.
Chapter 3, Operation and Maintenance	Describes the operation and maintenance modes of the ZXSDR R8882.
Chapter 4, Networking	Describes the networking modes supported by the ZXSDR R8882.
Chapter 5, Technical Specifications	Describes the technical specifications of the ZXSDR R8882.

Conventions

ZTE documents employ the following typographical conventions.

Typeface	Meaning
Italics	References to other Manuals and documents.
“Quotes”	Links on screens.

Typeface	Meaning
Bold	Menus, menu options, function names, input fields, radio button names, check boxes, drop-down lists, dialog box names, window names.
CAPS	Keys on the keyboard and buttons on screens and company name.
	Note: Provides additional information about a certain topic.
	Checkpoint: Indicates that a particular step needs to be checked before proceeding further.
	Tip: Indicates a suggestion or hint to make things easier or more productive for the reader.

Chapter 1

Product Overview

Table of Contents

Position of the ZXSDR R8882 in the Radio Network.....	1-1
Product Features.....	1-1
Services and Functions.....	1-3
Product Specifications.....	1-6
Installation Scenarios.....	1-7

1.1 Position of the ZXSDR R8882 in the Radio Network

The ZXSDR R8882 is the outdoor remote Radio Frequency (RF) unit of the ZTE Base Transceiver Station (BTS). The ZXSDR R8882 and a Base Band Unit (BBU) form a complete BTS/NodeB/eNodeB, implementing radio transmission in the covered area, controlling radio channels and realizing the communication with the Base Station Controller (BSC)/Radio Network Controller (RNC)/Long Term Evolution (LTE).

Figure 1-1 shows the position of the ZXSDR R8882 (RRU) in the radio network.

Figure 1-1 Position of the ZXSDR R8882 in the Radio Network

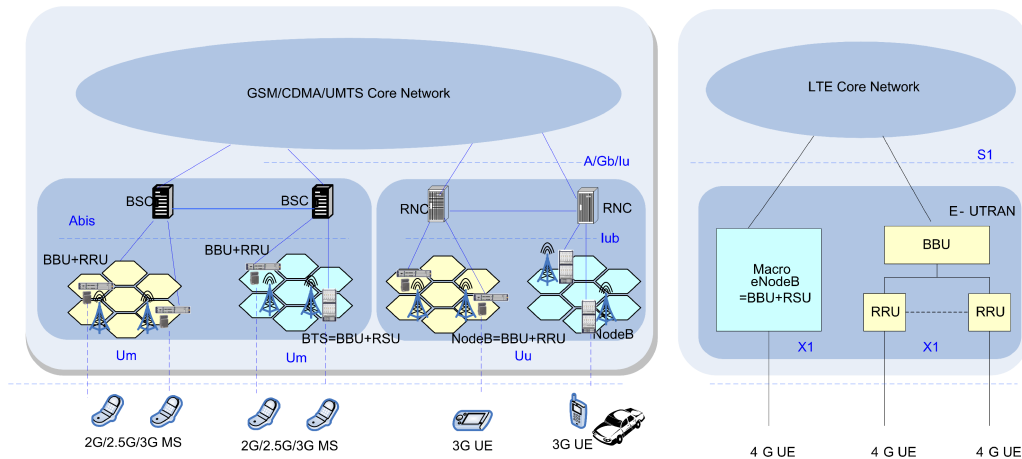

1.2 Product Features

The ZXSDR R8882 is an outdoor Remote Radio Unit (RRU) with dual transmitters. The ZXSDR R8882 works with a Baseband Unit (BBU) to provide all logical functions of a BTS.

Based on the digital intermediate frequency and multi-carrier technologies, the ZXSDR R8882 is capable of transmitting dual channels of radio signals and receiving four channels of radio signals. The ZXSDR R8882 can act as an independent remote RF unit for Global

System for Mobile Communication (GSM)/Universal Mobile Telecommunication System (UMTS)/Code Division Multiple Access (CDMA), and it supports evolution to LTE.

The features of the ZXSDR R8882 are as follows:

- Multiple radio access modes
The ZXSDR R8882 supports single mode, dual mode, or hybrid mode, including GSM, UMTS, CDMA, and LTE.
- Distributed architecture
BBUs and RRUs constitute distributed BTS systems, providing flexible office deployment.
- Smooth evolution
Through software upgrade, the ZXSDR R8882 can be smoothly evolved to HSPA or LTE, saving the investment of the telecom operator to the maximum.
- Flexible configuration and networking
 - Because the dual-density multi-carrier technologies are used, when the ZXSDR R8882 works in GSM mode, it supports 2 x 6 carriers through software configuration. (A single channel supports 6 carriers.)
 - When the ZXSDR R8882 works in UMTS mode, it supports up to 2 x 4 carriers. (A single channel supports 4 carriers.)
 - When the ZXSDR R8882 works in CDMA mode, it supports up to 2 x 8 carriers. (A single channel supports 8 carriers.)
 - When the ZXSDR R8882 works in GSM/UMTS dual mode, the ZXSDR R8882 supports 4 GSM carriers + 1 UMTS carrier or 2 GSM carriers + 2 UMTS carriers, and it supports up to 8 GSM carriers + 2 UMTS carriers.
 - When the ZXSDR R8882 works in LTE mode, the ZXSDR R8882 supports one carrier.
 - The baseband-RF interface of ZXSDR R8882 supports star and chain networking.
- Advanced internal structure
Between internal boards and modules, blind interconnection and hard link interconnection are used.
- Energy saving and environment-friendly design
Energy-saving and environment-friendly due to multi-carrier power amplifiers, and advanced Doherty and Digital Pre-Distortion (DPD) linear power amplification technologies.
- Easy installation and maintenance
Easy installation and maintenance due to compact size and light weight.

1.3 Services and Functions

Services

The ZXSDR R8882 works with BBUs to provide the following services:

- GSM
 - Full Rate (FR) voice service.
 - Enhanced Full Rate (EFR) voice service.
 - Half Rate (HR) voice service.
 - Adaptive Multiple Rate (AMR) voice service.
 - 9.6 Kbps Circuit Switched (CS) domain data service.
 - General Packet Radio Service (GPRS).
- UMTS
 - R99 services.
 - High Speed Downlink Packet Access (HSDPA) services.
 - High Speed Uplink Packet Access (HSUPA) services.
 - Evolved High-Speed Packet Access (HSPA+) services.
- CDMA
 - 1X service
 - Evolution-Data Optimized (EVDO) service
 - Push-To-Talk (PTT) service
- LTE
 - The capacity and data transmission speed of mobile network are greatly improved, and the service latency is lessened too. The peak data transmission rate are 50 Mbps(UL) and 100 Mbps(DL).
 - LTE is based on whole IP network, and it supports both IPv4 and IPv6.
 - LTE supports the configuration of 5 MHz, 10 MHz, 15 MHz and 20 MHz scalable bandwidth.
- Positioning services
 - Cell ID, Cell ID + Round Trip Time (RTT), and Assisted Global Positioning System (AGPS) positioning
- Multimedia Broadcast/Multicast Service (MBMS) services
 - Supports broadcast and multicast functions, and supports the Point-To-Point (PTP) and Point-To-Multipoint (PTM) multicast modes.
 - Supports mobility management.
 - Supports the streaming and background MBMS services.

Functions

- GSM/UMTS Mode

The ZXSDR R8882 works with BBUs to constitute the distributed BTS system. The ZXSDR R8882 forwards signals that are received or to be transmitted to the BBU for further processing. By connecting to the BBU, the ZXSDR R8882 provides the following functions:

- Through the Um/Uu interface, the ZXSDR R8882 provides access to terminals and provides RF link transmission functions, including channel multiplexing and de-multiplexing, measurement and report, power control, receive diversity, calibration, and synchronization.
- The ZXSDR R8882 is connected to the BBU through the optical interface. The optical interface implements the following functions: IQ data transmit, measurement information report, RF function configuration, and clock synchronization.
- Through the operation and maintenance interface, the ZXSDR R8882 provides the system management functions, including configuration management, alarm management, status check and monitoring.
- The ZXSDR R8882 also provides other basic functions:
 - ◆ Supports GSM Phase I/Phase II/Phase II +.
 - ◆ Supports GSM 900 M and GSM 1800 M.
 - ◆ Supports UMTS R99, R4, R5, R6, R7, and R8.
 - ◆ Supports UMTS 850M, 900M, 1900M, and 2100M. Supports hybrid networking of different modes and different frequency bands.
 - ◆ Supports GPRS CS1 to CS4 encoding modes.
 - ◆ Supports space diversity, frequency diversity, time diversity, and polarization diversity.
 - ◆ The receive end supports the Viterbi decoding algorithm, improving the system receive sensibility and channel decoding capability.
 - ◆ Supports frequency hopping.
 - ◆ Supports Discontinuous Transmission (DTX).
 - ◆ Support Timing Advance (TA) calculation and super-distance coverage. The maximum coverage distance is 120 km.
 - ◆ Supports Co-Broadcast Control CHannel (BCCH).

- CDMA Mode

When the ZXSDR R8882 works in CDMA mode, it provides the following functions:

- Basic RF functions
 - ◆ Frequency band range: 850 MHz/1900 MHz

- ◆ RF modulation and demodulation
- ◆ Duplex RF transmitting and receiving
- ◆ Low-noise amplification of received RF signals
- ◆ Amplification of transmitted RF signals
- ◆ RF transceiver
- Interface
 - ◆ The Common Public Radio Interface (CPRI) interface complies with the CPRI protocol, supporting transmission through fibers and high-speed cables.
 - ◆ The air interface complies with the IS-2000 Release A series standards and IS-856-A standard.
- Device maintenance and test
 - ◆ Front maintenance
 - ◆ Remote version upgrade of the software such as FPGA, BOOT, DSP, and CPU
 - ◆ Remote reset of service boards
 - ◆ Electronic label
 - ◆ Power query: baseband power, RF power
 - ◆ Auto calibration
 - ◆ Received Signal Strength Indicator (RSSI) query
 - ◆ Reverse spectrum query. Supports query of the spectrum of the signals received by each carrier in the reverse direction.
 - ◆ Provides power amplifier control and protection functions, including over-power-amplification alarms, over-temperature alarms, and Standing Wave Ratio (SWR) alarms.
- Reliability
 - Supports protection against reverse power connection.
- Application scenario
 - ◆ Supports indoor and outdoor applications.
- LTE Mode

When the ZXSDR R8882 works in LTE mode, it provides the following functions:

 - Basic RF functions
 - ◆ Frequency band range: 1800MHz
 - ◆ Supports QPSK, 16-QAM, 64-QAM on downlink.
 - ◆ Supports QPSK, 16-QAM, 64-QAM on uplink.
 - ◆ Supports RF channel grid.

- ◆ Supports MIMO.
- Interface
 - ◆ CPRI interface apply to CPRI protocol, which supports both optical fiber and SFP cable.
 - ◆ Supports measurement of propagation delay and compensation of propagation delay.
- Device maintenance and test
 - ◆ Supports FPGA / BOOT / DSP / CPU software version upgrade remotely.
 - ◆ Supports board resetting remotely.
 - ◆ Supports both baseband power inquiry and RF power inquiry.
 - ◆ Supports alarm inquiry.
 - ◆ Supports real-time report when alarm occurs.
 - ◆ Supports AISG antenna management both remotely and locally.
 - ◆ Supports hardware version and software version inquiry.
- Reliability
 - Supports anti-misplug for power socket connection
- Application scenario
 - Supports indoor and outdoor deployment.

1.4 Product Specifications

Table 1-1 shows the specifications of the ZXSDR R8882.

Table 1-1 Product Specifications

Product Specifications	Description
ZXSDR R8882 S9000(C)	Three optical ports; a maximum of 6 Gbps; GSM single mode; 900 MHz frequency band; 2 x 60 W
ZXSDR R8882 S1800(C)	Three optical ports; a maximum of 6 Gbps; GSM single mode, 1800 MHz frequency band; 2 x 60 W
ZXSDR R8882 S9000(B)	Two optical ports; a maximum of 3 Gbps; GSM single mode, UMTS single mode, or GSM/UMTS dual mode; 900 MHz frequency band; 2 x 60 W
ZXSDR R8882 S8500(B)	Two optical ports; a maximum of 3 Gbps; CDMA single mode, GSM/UMTS dual mode, or CDMA/LTE dual mode; 850 MHz frequency band; 2 x 60 W
ZXSDR R8882 S8000(B)	Two optical ports; a maximum of 3 Gbps; LTE single mode ; DD frequency band; 2 x 40 W

Product Specifications	Description
ZXSDR R8882 S2600(B)	Two optical ports; a maximum of 3 Gbps; LTE single mode ; 2.6 Gbps frequency band; 2 x 30 W
ZXSDR R8882 S2100(B)	Two optical ports; a maximum of 3 Gbps; UMTS single mode; 2T4R; 2100 MHz frequency band; 2 x 60 W
ZXSDR R8882 S1900(B)	Two optical ports; a maximum of 3 Gbps; CDMA single mode, GSM/UMTS dual mode, or CDMA/LTE dual mode; 2T4R; 1900 MHz frequency band; 2 x 50 W
ZXSDR R8882 S1800(B)	Two optical ports; a maximum of 3 Gbps; GSM single mode, or GSM/LTE dual mode; 2T4R; 1800 MHz frequency band; 2 x 60 W
ZXSDR R8882 S1700(B)	Two optical ports; a maximum of 3 Gbps; LTE single mode ; AWS frequency band; 2 x 40 W

1.5 Installation Scenarios

The ZXSDR R8882 supports the following installation modes: wall-mounting, pole-mounting, and L-shape gantry-mounting.

- Wall-mounting

The ZXSDR R8882 can be wall-mounted indoor or outdoor.

- Pole-mounting

In pole-mounting installation, you can install one, two, three, or four ZXSDR R8882 devices on one pole.

- L-shape gantry mounting

This page intentionally left blank.

Chapter 2

System Structure

Table of Contents

Hardware Subsystem2-1
 Software Subsystem2-3

2.1 Hardware Subsystem

2.1.1 Hardware Architecture

Figure 2-1 takes three-port ZXSDR R8882 for example to show the general hardware architecture of ZXSDR R8882.

Figure 2-1 Hardware System Three optical ports

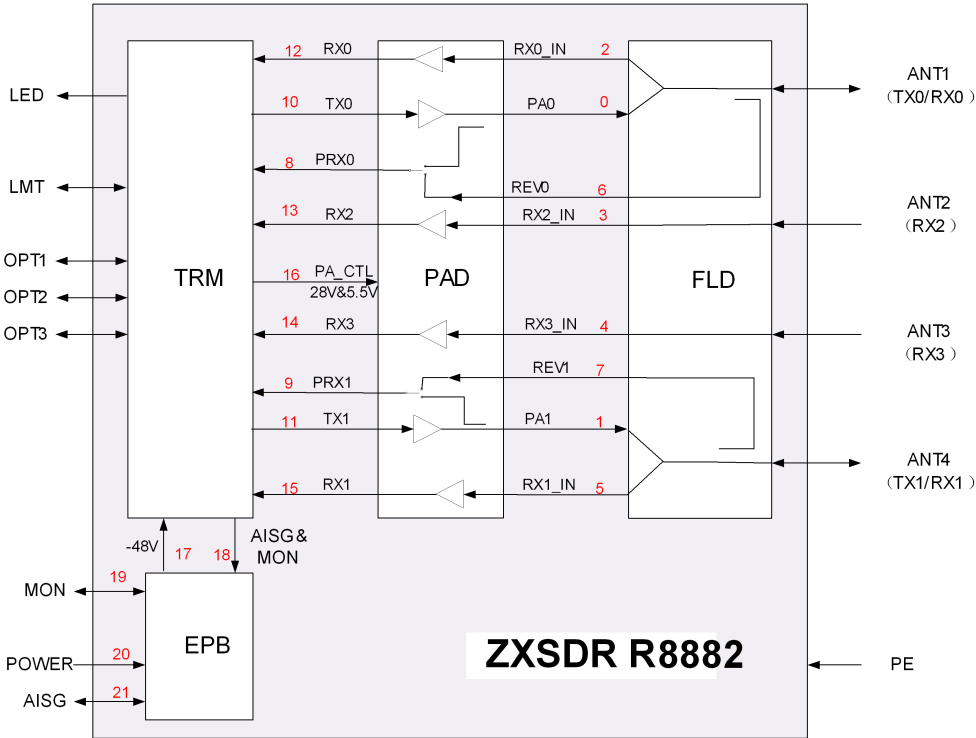

NOTE

The ZXSDR R8882 with two optical ports has no OPT3 interface.

ZXSDR R8882 contains four modules: TRM, PAD, FLD, and EPB, as introduced in [Table 2-1](#).

Table 2-1 Hardware Modules

Code	Module	Function
TRM	Multi-mode TRX module	Provides two transmitters and four receivers for transmitting and receiving radio signals.
PAD	Power amplification module	Implements the amplification of two RF signals to be transmitted, and the LNA amplification of four received RF signals.
FLD	Duplexer and filter	Provides a dual-channel duplexer and a four-channel filter, implementing the forward and backward coupling of Tx power.
EPB	EMC protection module	Provides EMC protection for the power interface, monitoring interface, and the AISG interface.

2.1.2 Module Functions

The following describes the functions of each hardware module in ZXSDR R8882.

TRM

- Optical interface processing
- Clock processing
- Uplink and downlink processing
- Frequency hopping
- Adaptive modulation rate
- Monitoring
- Indication
- Power supply and on-off switch
- Reset switch
- Interfaces for connecting external devices

PAD

- Amplifies downlink radio signals received from the TRM, and outputs the amplified signals to the FLD.
- Amplifies four signals received from the FLD with the LNA, and then sends the amplified signals to the TRM.
- Provides a pre-distortion feedback interface to the TRM.
- Provides an interface to the TRM for Voltage Standing Wave Ratio (VSWR) detection (forward power detection).
- Supports separate switch-off.
- Supports Inner-module temperature detection.
- Provides read and write interfaces for module inventory management.

FLD

- Transmits and receives uplink and downlink signals in duplex mode.
- Suppresses spurious emission on the downlink to get acceptable out-band Tx spurious emission required by the system and related protocol.
- Suppresses interference signals on the uplink to achieve a satisfied noise coefficient.

EPB

- Provides the lightning protection for -48 V power supply.
- Provides -48 V power filter.
- Protects AISG signals (14 V, half-duplex 485 signal).
- Protects three pairs of dry contacts.
- Protects the RS485 monitoring signals.
- Provides adaptation for external MON interface, AISG interface, and power interface.
- Provides the hardware version identifiers of boards.

2.2 Software Subsystem

2.2.1 Software Architecture

The software subsystem of ZXSDR R8882 contains lower-layer software of boards, and L2 software, L3 software and applications operating on a Linux operating system. For the software architecture of ZXSDR R8882, see [Figure 2-2](#).

Figure 2-2 Software Architecture

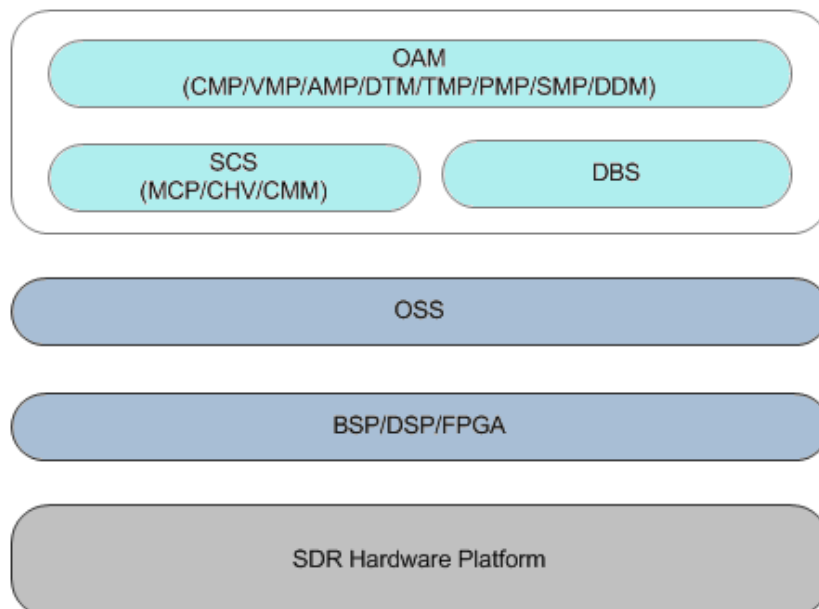

- OAM: Operation, Administration and Maintenance
- SCS: System Control Subsystem
- DBS: Database Subsystem
- OSS: Operation Support Subsystem
- BSP: Board Support Package
- DSP: Digital Signal Processing
- FPGA: Field Programmable Gate Array

- SDR: Software Defined Radio

2.2.2 Software Functions

- The lower-layer software modules of boards include Board Support Package (BSP), Digital Signal Processing (DSP), and Field Programmable Gate Array (FPGA).
 - The BSP module initializes the system hardware and provides driver interface functions.
 - The DSP module exchanges information with the CPU, and exchanges control signals and data with the FPGA module. In addition, it implements maintenance and measurement functions such as extracting and updating pre-distortion parameters, and detecting errors and alarms.
 - The FPGA module exchanges control signals and data with the DSP module.
- The Operation Support Subsystem (OSS) is a support layer for the entire software. It provides a hardware irrelevant platform on which the system software operates to provide basic software function, such as scheduling, timing, memory management, inter-module communication, queuing controlling, monitoring, alarm management, and log management.
- The L3 software on the Layer-3 platform contains three parts: Operation, Administration and Maintenance (OAM), System Control Subsystem (SCS), and Database Subsystem (DBS).
 - The OAM provides the functions of version management, diagnosis test, configuration management, tool management, performance management, system management, dynamic data management, and communication management.
 - The SCS controls the power-on sequence, active/standby switchover, and Intelligent Platform Management Interface (IPMI).
 - The DBS manages the system database.

Chapter 3

Operation and Maintenance

Table of Contents

Operation and Maintenance Modes.....	3-1
Operation and Maintenance Functions	3-2

3.1 Operation and Maintenance Modes

Remote Maintenance Mode

In remote maintenance, the NetNumen™ M3 OMC of ZTE is connected to the BSC/RNC/BBU, and then connected to the ZXSDR R8882 through the Abis/Iub/CPRI interface. In this way, you can operate and maintain the ZXSDR R8882 through the OMC. [Figure 3-1](#) shows the networking.

Figure 3-1 Remote Maintenance Mode (Taking CDMA and GSM for Example)

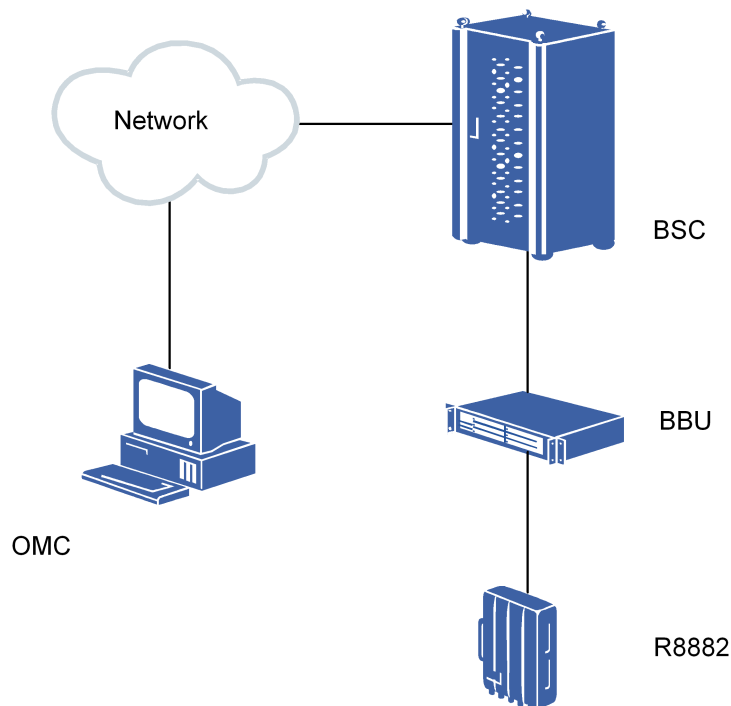

In remote maintenance mode, the OMC and NEs are connected through the TCP/IP protocol. One OMC can maintain multiple BTSs.

Local Maintenance Mode

In local maintenance mode, the Local Maintenance Terminal (LMT), usually a PC, is connected to the ZXSDR R8882 through an Ethernet cable. Figure 3-2 shows the networking.

Figure 3-2 Local Maintenance Mode

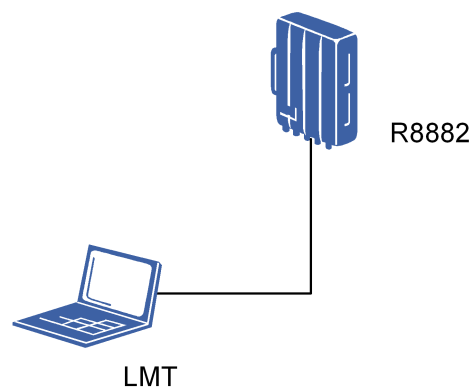

Through the LMT, you can query the power, increase or decrease the power, and perform calibration on the ZXSDR R8882. Through the LMT, you can maintain the entire BTS.

3.2 Operation and Maintenance Functions

The NetNumen™ M3 OMC provides a topological view on the GUI interface. Through the GUI interface, users can view the information about all the NEs in the entire network. The users can select a required NE and view its detailed performance data, alarm information, and configuration data. They can also operate and maintain one type of NEs through the topological view. The OMC provides the following functions:

- Configuration management
Adds, queries, deletes, modifies physical and radio resource data of BTSs. Performs data consistency check; and supports dynamic and static data configuration modes.
- Security management
Ensures that only authorized users can perform the specified groups of commands.
- Performance management
Supports performance analysis, invocation tracing, and signaling tracing.
- Version management
Through the OMC, users can query the software and hardware versions that are in use. The OMC provides the software download mechanism, supporting software upgrade of NEs.
- Fault management
Supports alarm management and diagnosis test. Monitors the BTS operating status in a centralized manner; Collects abnormal information of boards and links in real time,

which helps the operation and maintenance personnel to determine the equipment faults and maintain the equipment.

This page intentionally left blank.

Chapter 4

Networking

Table of Contents

- Star Networking.....4-1
- Cascade Networking4-1
- Ring Networking.....4-2

4.1 Star Networking

Figure 4-1 shows the star networking of a BBU and multiple RRUs (ZXSDR R8882).

Figure 4-1 Star Networking

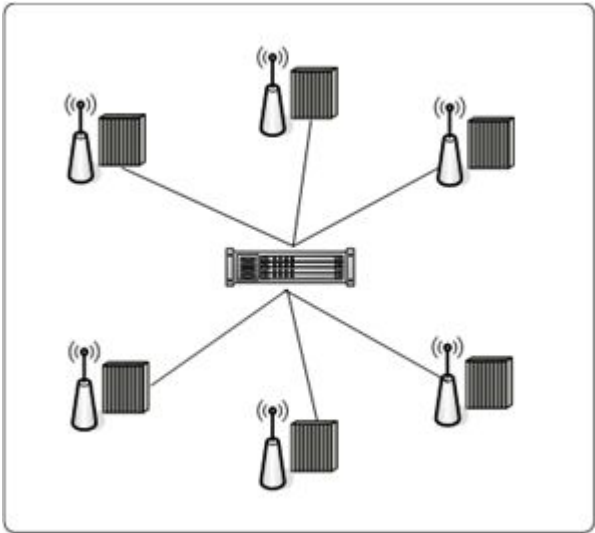

4.2 Cascade Networking

Figure 4-2 shows the cascade networking of a BBU and multiple RRUs (ZXSDR R8882).

Figure 4-2 Cascade Networking

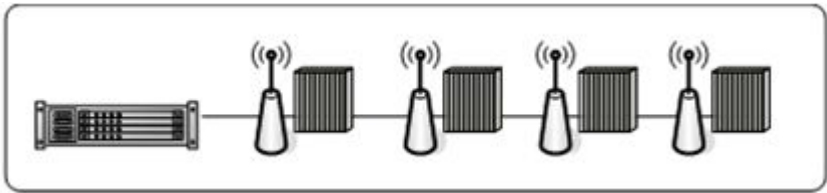

4.3 Ring Networking

Figure 4-3 shows the ring networking of a BBU and multiple RRUs (ZXSDR R8882).

Figure 4-3 Ring Networking

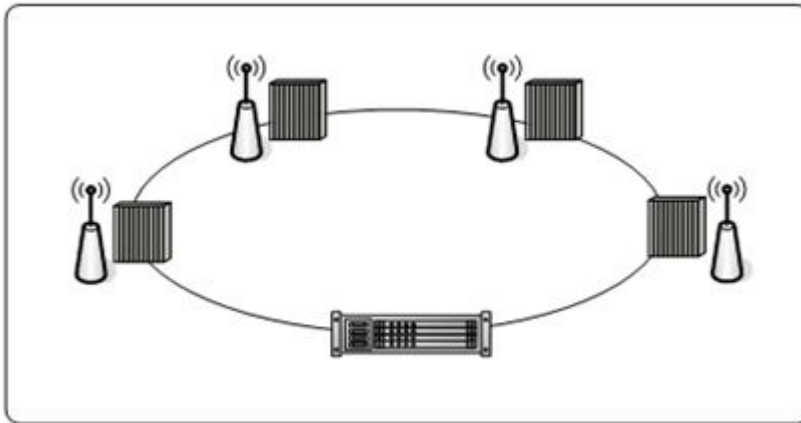

When ZXSDR R8882 provides three optical ports, chain (cascading) networking can be added to the ring networking, as shown in Figure 4-4.

Figure 4-4 Ring and Chain Networking (with Three Optical Ports)

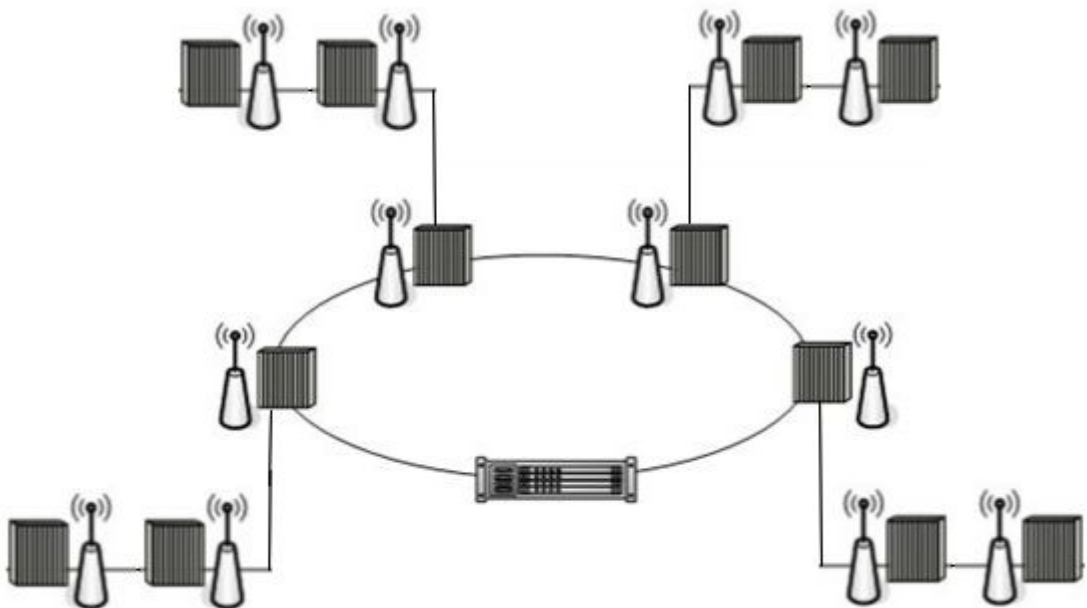

Chapter 5

Technical Specifications

Table of Contents

Physical Specifications	5-1
Radio Performance	5-2
Interfaces	5-3

5.1 Physical Specifications

Appearance

Item	Specifications
Dimensions	480 mm × 320 mm × 150 mm (Height × Width × Depth)
Weight	27 kg
Color	White

Power Supply Requirements and Power Consumption

Item	Specifications
Average power consumption in GSM single mode	<ul style="list-style-type: none"> ● 310 W (850 M/900 M) ● 320 W (1800 M/1900 M)
Average power consumption in UMTS single mode	<ul style="list-style-type: none"> ● 310 W (850 M/900 M) ● 320 W (1900 M/2100 M)
Average power consumption in CDMA single mode	<ul style="list-style-type: none"> ● 310 W (850 M) ● 320 W (1900 M)
Average power consumption in LTE single mode	320 W (1800M)
Rated input voltage	-48V (-60 V DC to -37 V DC)

Environmental Requirements

Item	Requirement	
Operation	Ambient temperature	-40 °C to +55 °C
	Relative humidity	10 % to 100%

Item		Requirement
Storage	Ambient temperature	-60 °C to +70 °C
	Relative humidity	5 % to 100 %
Transportation condition		In condition of 4K2, 4Z5, 4Z7, 4B1, 4C2, 4S3, or 4M3, the transportation must be completed within 180 days.

Reliability

Item	Specifications
Availability	99.9995%
Mean Time Between Critical Failures (MTBF)	≥100,000 hours
Mean Time To Recovery (MTTR)	0.5 hour
System service interruption time	The service interruption time of the entire system is no more than 1.632 minutes per year.

Wind Load

Wind Speed	Front	Side	Rear
150 km/h	422 N	197 N	422 N
240 km/h	1092 N	510 N	1092 N

5.2 Radio Performance

Capacity Specifications

Item	Specifications
GSM single mode	Maximum: 2 x 6 carriers
UMTS single mode	Maximum: 2 x 4 carriers
CDMA single mode	Maximum: 2 x 8 carriers
GSM/UMTS dual mode	2 x 4 GSM carriers + 2 x 1 UMTS carriers, or 2 x 2 GSM carriers + 2 x 2 UMTS carriers
LTE single mode	1 carrier

RF Specifications

Item	Specifications
Working frequency band	<ul style="list-style-type: none"> ● GSM:850 MHz/900 MHz/1800 MHz/1900 MHz ● UMTS: 850 MHz/900 MHz/1900 MHz/2100 MHz ● CDMA:850 MHz/1900 MHz ● LTE: 1800 MHz
Maximum transmit power	2 x 60 W
Static receiver sensibility	<ul style="list-style-type: none"> ● GSM:-113 dBm (TCH/FS) ● UMTS single antenna: -125.5 dBm ● UMTS dual antennas: -128.2 dbm ● CDMA: -115 dBm

5.3 Interfaces

The ZXSDR R8882 provides the following interfaces:

Item	Specifications
Baseband-RF interface (optical port)	<p>ZXSDR R8882 S9000(C) Provides three optical ports:</p> <ul style="list-style-type: none"> ● OPT1: the interface through which the ZXSDR R8882 is cascaded to a BBU ● OPT2: the interface through which the ZXSDR R8882 is cascaded to an RRU ● OPT3: the interface through which the ZXSDR R8882 is cascaded to a branch RRU <p>ZXSDR R8882 S1800(C) Provides three optical ports:</p> <ul style="list-style-type: none"> ● OPT1: the interface through which the ZXSDR R8882 is cascaded to a BBU ● OPT2: the interface through which the ZXSDR R8882 is cascaded to an RRU ● OPT3: the interface through which the ZXSDR R8882 is cascaded to a branch RRU <p>ZXSDR R8882 S9000(B) Provides two optical ports:</p> <ul style="list-style-type: none"> ● OPT1: the interface through which the ZXSDR R8882 is cascaded to a BBU ● OPT2: the interface through which the ZXSDR R8882 is cascaded to an RRU <p>ZXSDR R8882 S8500(B) Provides two optical ports:</p>

Item	Specifications
	<ul style="list-style-type: none"> ● OPT1: the interface through which the ZXSDR R8882 is cascaded to a BBU ● OPT2: the interface through which the ZXSDR R8882 is cascaded to an RRU <p>ZXSDR R8882 S8000(B) Provides two optical ports:</p> <ul style="list-style-type: none"> ● OPT1: the interface through which the ZXSDR R8882 is cascaded to a BBU ● OPT2: the interface through which the ZXSDR R8882 is cascaded to an RRU <p>ZXSDR R8882 S2600(B) Provides two optical ports:</p> <ul style="list-style-type: none"> ● OPT1: the interface through which the ZXSDR R8882 is cascaded to a BBU ● OPT2: the interface through which the ZXSDR R8882 is cascaded to an RRU <p>ZXSDR R8882 S2100(B) Provides two optical ports:</p> <ul style="list-style-type: none"> ● OPT1: the interface through which the ZXSDR R8882 is cascaded to a BBU ● OPT2: the interface through which the ZXSDR R8882 is cascaded to an RRU <p>ZXSDR R8882 S1900(B) Provides two optical ports:</p> <ul style="list-style-type: none"> ● OPT1: the interface through which the ZXSDR R8882 is cascaded to a BBU ● OPT2: the interface through which the ZXSDR R8882 is cascaded to an RRU <p>ZXSDR R8882 S1800(B) Provides two optical ports:</p> <ul style="list-style-type: none"> ● OPT1: the interface through which the ZXSDR R8882 is cascaded to a BBU ● OPT2: the interface through which the ZXSDR R8882 is cascaded to an RRU <p>ZXSDR R8882 S1700(B) Provides two optical ports:</p> <ul style="list-style-type: none"> ● OPT1: the interface through which the ZXSDR R8882 is cascaded to a BBU ● OPT2: the interface through which the ZXSDR R8882 is cascaded to an RRU
MON interface	One MON interface, through which the external monitoring devices are connected, providing input of RS485 signals and two pairs of dry contacts.

Item	Specifications
Ethernet interface	One Ethernet interface, which is used for local maintenance.
Antenna and feeder interface	Four antenna and feeder interfaces through which antennas and feeders are connected.
AISG interface	One AISG interface, which is used for the electrical tilt tunable antenna.
Power interface	One power interface, which provides external power input.
Protective Earth (PE) interface	One PE interface, through which the ZXSDR R8882 is connected to the PE.

This page intentionally left blank.

Chapter 6

FCC & IC STATEMENT

This device complies with Part 15 of the FCC Rules. Operation is subject to the following two conditions:

1. This device may not cause harmful interference.
2. This device must accept any interference received, including interference that may cause undesired operation.



Note:

This equipment has been tested and found to comply with the limits for a Class A digital device, pursuant to Part 15 of the FCC Rules. These limits are designed to provide reasonable protection against harmful interference when the equipment is operated in a commercial environment. This equipment generates, uses, and can radiate radio frequency energy and, if not installed and used in accordance with the instruction manual, may cause harmful interference to radio communications.



Warning!

Changes or modifications to this unit not expressly approved by the party responsible for compliance could void the user's authority to operate the equipment.

Operation of this equipment in a residential area is likely to cause harmful interference in which case the user will be required to correct the interference at his own expense.

This page intentionally left blank.

Figures

Figure 1-1	Position of the ZXSDR R8882 in the Radio Network	1-1
Figure 2-1	Hardware System Three optical ports	2-1
Figure 2-2	Software Architecture.....	2-3
Figure 3-1	Remote Maintenance Mode (Taking CDMA and GSM for Example).....	3-1
Figure 3-2	Local Maintenance Mode	3-2
Figure 4-1	Star Networking	4-1
Figure 4-2	Cascade Networking.....	4-1
Figure 4-3	Ring Networking	4-2
Figure 4-4	Ring and Chain Networking (with Three Optical Ports).....	4-2

This page intentionally left blank.

Tables

Table 1-1	Product Specifications	1-6
Table 2-1	Hardware Modules	2-2

This page intentionally left blank.

Index

F

feature..... 1-1

I

installation scenario..... 1-7

N

networking

 cascade 4-1

 ring 4-2

 ring and chain 4-2

 star 4-1

O

operation and maintenance

 function 3-2

operation and maintenance mode

 local..... 3-2

 remote 3-1

P

position in network..... 1-1

R

radio access mode 1-2

S

Services and Functions 1-3

specifications

 interface..... 5-3

 physical 5-1

 product 1-6

 radio performance..... 5-2

structure

 hardware 2-1

 software..... 2-3

This page intentionally left blank.

Glossary

AGPS

- Assisted Global Positioning System

AMR

- Adaptive Multiple Rate

BBU

- BaseBand Unit

BCCH

- Broadcast Control CHannel

BSC

- Base Station Controller

BSP

- Board Support Package

BTS

- Base Transceiver Station

CDMA

- Code Division Multiple Access

CPRI

- Common Public Radio Interface

CS

- Circuit Switched

DBS

- Database Subsystem

DPD

- Digital Pre-Distortion

DSP

- Digital Signal Processing

DTX

- Discontinuous Transmission

EFR

- Enhanced Full Rate

EMC

- Electromagnetic Compatibility

EVDO

- Evolution-Data Optimized

FDD

- Frequency Division Duplex

FPGA

- Field Programmable Gate Array

FR

- Full Rate

GPRS

- General Packet Radio Service

GSM

- Global System for Mobile Communication

HR

- Half Rate

HSDPA

- High Speed Downlink Packet Access

HSPA

- High Speed Packet Access

HSUPA

- High Speed Uplink Packet Access

IPMI

- Intelligent Platform Management Interface

LMT

- Local Maintenance Terminal

LNA

- Low Noise Amplifier

LTE

- Long Term Evolution

MBMS

- Multimedia Broadcast/Multicast Service

MTBF

- Mean Time Between Failures

MTTR

- Mean Time To Recovery

OAM

- Operation, Administration and Maintenance

OSS

- Operation Support Subsystem

PE

- Protective Earth

PTM

- Point To Multipoint

PTP

- Point-To-Point

PTT

- Push-To-Talk

RF

- Radio Frequency

RNC

- Radio Network Controller

RRU

- Remote Radio Unit

RSSI

- Received Signal Strength Indicator

RTT

- Round Trip Time

SCS

- System Control Subsystem

SDR

- Software Defined Radio

SWR

- Standing Wave Ratio

TA

- Timing Advance

UMTS

- Universal Mobile Telecommunication System

VSWR

- Voltage Standing Wave Ratio