



ZXSDR R8964

TD-LTE Remote Radio Unit

User Manual

Version: V5.00

ZTE CORPORATION
No. 55, Hi-tech Road South, ShenZhen, P.R.China
Postcode: 518057
Tel: +86-755-26771900
Fax: +86-755-26770801
URL: <http://support.zte.com.cn>
E-mail: support@zte.com.cn

LEGAL INFORMATION

Copyright © 2013 ZTE CORPORATION.

The contents of this document are protected by copyright laws and international treaties. Any reproduction or distribution of this document or any portion of this document, in any form by any means, without the prior written consent of ZTE CORPORATION is prohibited. Additionally, the contents of this document are protected by contractual confidentiality obligations.

All company, brand and product names are trade or service marks, or registered trade or service marks, of ZTE CORPORATION or of their respective owners.

This document is provided “as is”, and all express, implied, or statutory warranties, representations or conditions are disclaimed, including without limitation any implied warranty of merchantability, fitness for a particular purpose, title or non-infringement. ZTE CORPORATION and its licensors shall not be liable for damages resulting from the use of or reliance on the information contained herein.

ZTE CORPORATION or its licensors may have current or pending intellectual property rights or applications covering the subject matter of this document. Except as expressly provided in any written license between ZTE CORPORATION and its licensee, the user of this document shall not acquire any license to the subject matter herein.

ZTE CORPORATION reserves the right to upgrade or make technical change to this product without further notice. Users may visit ZTE technical support website <http://ensupport.zte.com.cn> to inquire related information.

The ultimate right to interpret this product resides in ZTE CORPORATION.

Revision History

Revision No.	Revision Date	Revision Reason
R1.0	2013-09-12	First edition

Serial Number: SJ-20110921170448-002

Publishing Date: 2013-09-12(R1.0)

About This Manual

Purpose

This manual describes ZXSDR R8964 device description, technical specifications, and maintenance.

Intended Audience

This document is intended for:

- Commissioning and maintenance engineer
- Hardware installation and site testing engineer

Prerequisite Skill and Knowledge

To use this document effectively, users should have a general understanding of wireless telecommunications technology. Familiarity with LTE system and its various components is helpful.

What Is in This Manual

This manual contains the following chapters:

Chapter	Summary
Chapter 1 FCC Statement	Describes the FCC statement related to the device.
Chapter 2 Product Overview	Describes product function, typical application, networking mode, technical indices, etc.
Chapter 3 Technical Specification	Describes product indices.
Chapter 4 Product Description	Describes product interfaces, indicators and cables.
Chapter 5 Product Maintenance	Describes product cable replacement.

Chapter 1

FCC Statement



Note:

This equipment has been tested and found to comply with the limits for a Class A digital device, pursuant to Part 15 of the FCC Rules. These limits are designed to provide reasonable protection against harmful interference when the equipment is operated in a commercial environment. This equipment generates, uses, and can radiate radio frequency energy and, if not installed and used in accordance with the instruction manual, may cause harmful interference to radio communications. Operation of this equipment in a residential area is likely to cause harmful interference in which case the user will be required to correct the interference at his own expense.

Cable loss between transmitter and antenna is 1dB.



Note:

Operation of this equipment in a residential area is likely to cause harmful interference in which case the user will be required to correct the interference at his own expense.



Note:

FCC Radiation Exposure Statement: This equipment complies with FCC radiation exposure limits set forth for an uncontrolled environment. This equipment should be installed and operated with minimum distance 8 m between the radiator & your body.

This page intentionally left blank.

Chapter 2

Product Overview

Table of Contents

ZTE Distributed Base Station Solution.....	2-1
RRU Location in LTE Wireless Network.....	2-2
RRU Typical Application.....	2-2
Device Appearance.....	2-3
Device Functions.....	2-4
Device Features.....	2-4
Device Installation Scenarios.....	2-5
Device Networking.....	2-5
Operation and Maintenance Introduction.....	2-5

2.1 ZTE Distributed Base Station Solution

To supply the customer with more competitive communication equipment and solution in the market, ZTE develops and promotes ZTE **SDR BBU** (baseband unit) +**RRU** (remote RF unit) distributed BS solution timely, which jointly perform LTE BS service.

ZTE's LTE BBU+RRU distributed BS solution has the following predominance:

1. Clearer and Simpler Network

Instead of running hardware independent platforms for each technology, operators can have various wireless technologies implemented in software on the same hardware platform.

2. Lower TCO (Total Cost of Ownership)

Fewer engineers are required since there is a single platform to manage and maintain. The operational expenditures are kept to minimum compared to running several hardware platforms.

The TCO for a mobile network is much lower in performing upgrades for the new wireless technology due to multi-technology deployment supported by SDR-platform.

3. Lower Investment Risk

Since hardware platforms can be reused, there is significantly less investment risk for deploying hardware. Wireless technologies develop so fast, and investing on one technology only may bring risk to operators. SDR-based solutions will decrease the investment risk since SDR platform can support various technologies.

2.2 RRU Location in LTE Wireless Network

ZXSDR R8964 is a compact LTE remote radio frequency unit, which adopts the digital pre-distortion technology, high-efficiency power amplifier technology and SDR technology. ZXSDR R8964 and BBU form an integrated eNodeB to accomplish radio transmission within its coverage and control radio channels.

Figure 2-1 illustrates the position of ZXSDR R8964 (RRU) in network.

Figure 2-1 Device Location in Network

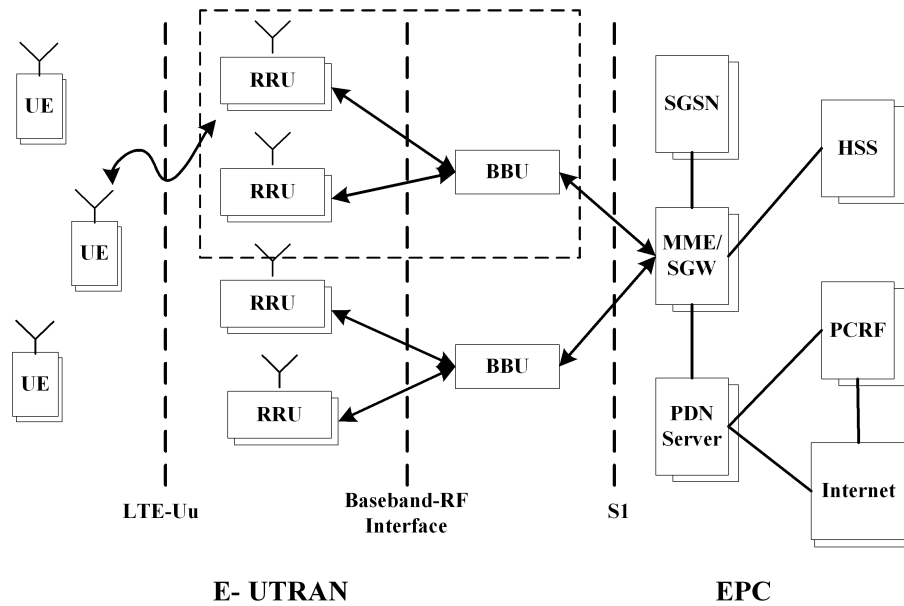

2.3 RRU Typical Application

Figure 2-2 illustrates the typical application of ZXSDR R8964.

Figure 2-2 RRU Typical Application

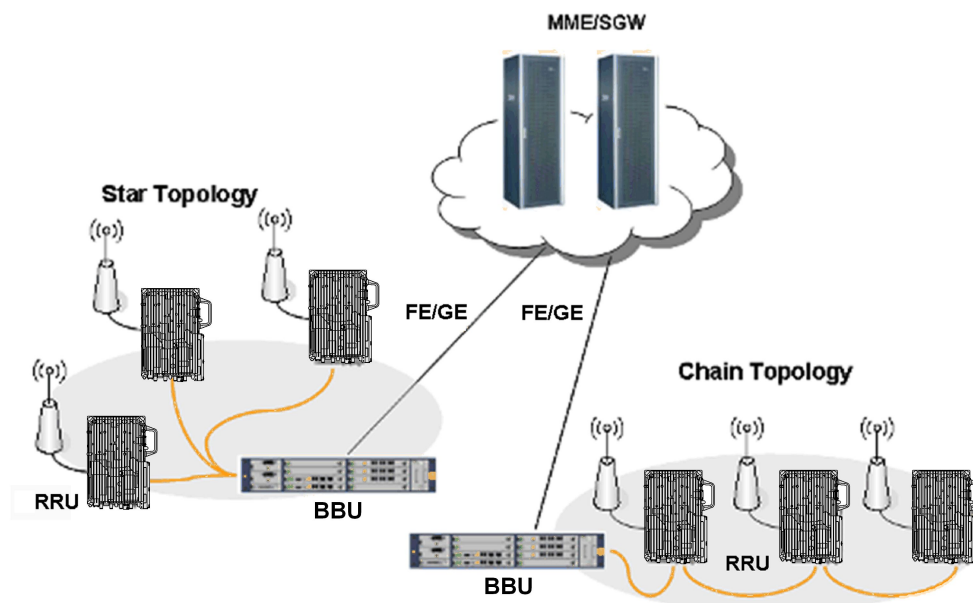

2.4 Device Appearance

The appearance of ZXSDR R8964 is shown in Figure 2-3.

Figure 2-3 Device Appearance

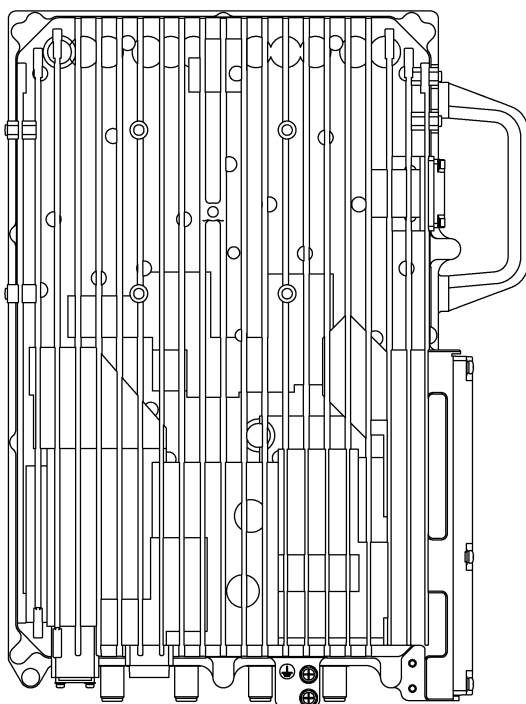

2.5 Device Functions

ZXSDR R8964 has following main functions:

- Supports channel bandwidth 10 MHz and 20 MHz.
- Supports frequency:
 - 2300 MHz ~ 2400 MHz
 - 2496 MHz ~ 2690 MHz
 - 3400 MHz ~ 3600 MHz (S3500-supported band)
 - 3600 MHz ~ 3700 MHz (S3600-supported band)
- Supports 2x2 MIMO, 4x4 MIMO.
- Supports Optical interface.
- Supports time slot switching point configuration of uplink and downlink.
- Supports measurement and compensation function of the fiber to BBU.
- Supports power measurement of carrier.
- Supports version management function.
- Supports performance management function.
- Supports malfunction management function.
- Supports security management function.
- Supports operation & maintenance function.
- Supports power management function.
- Supports transparent channel function.
- Supports LMT.

2.6 Device Features

ZXSDR R8964 is a single-mode outdoor RRU based on ZTE SDR platform, which can be used with ZTE's BBU series product to form a distributed base station.

The main characteristics of ZXSDR R8964 are described as follows:

- Unified Platform

ZXSDR R8964 adopts unified SDR platform to protect operators' investment and support smooth evolution.
- Higher Efficiency for Energy Saving
 - Multiple high-efficiency power amplifier technologies were used, like CFR, DPD and Doherty.
 - ZXSDR R8964 adopts natural cooling design without noise. At the same time, it can save power consumption compare with traditional air-condition system.
 - Using "BBU+RRU" solution to reduce feeder loss and lower power requirements of PA to realize green network.
- Compact Design, Easy Deployment
 - The volume of ZXSDR R8964 is 17.1 liters.

- ZXSDR R8964 can be installed to pole and mounted on the wall. The flexibility of installation benefits to reduce cost for operators.
- Multi-antenna Capability
ZXSDR R8964 supports multiple MIMO solution. It can improved frequency efficiency greatly and brings excellent user experience.

2.7 Device Installation Scenarios

ZXSDR R8964 supports wall-mounted installation and pole-mounted installation. .

2.8 Device Networking

ZXSDR R8964 is connected to BBU through optical fiber port. It supports star networking mode.

The ZXSDR R8964 typical star networking topology is shown in Figure 2-4.

Figure 2-4 Start Networking Mode

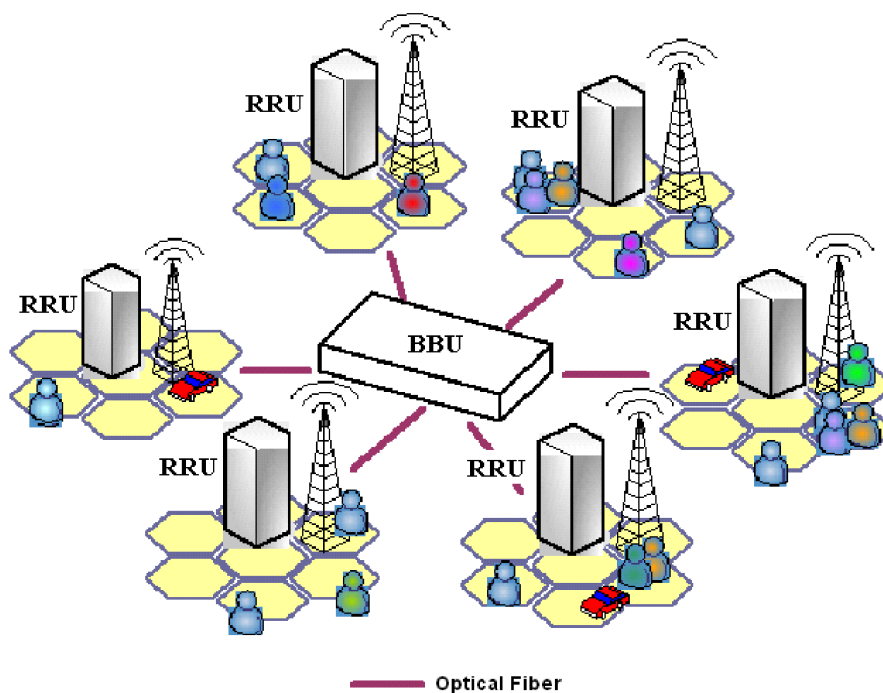

2.9 Operation and Maintenance Introduction

LMT Mode

Users can use a LMT to accomplish the operation, maintenance and management of ZXSDR R8964, as shown in Figure 2-5.

Figure 2-5 LMT Mode

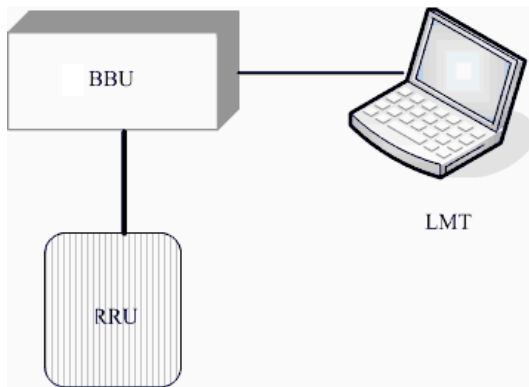

Network Management Mode

Users can use NetNumen™ network management system developed by ZTE to accomplish the operation, maintenance and management of ZXSDR R8964. NEs are connected to the network management system through TCP/IP, as shown in Figure 2-6.

Figure 2-6 Network Management Mode

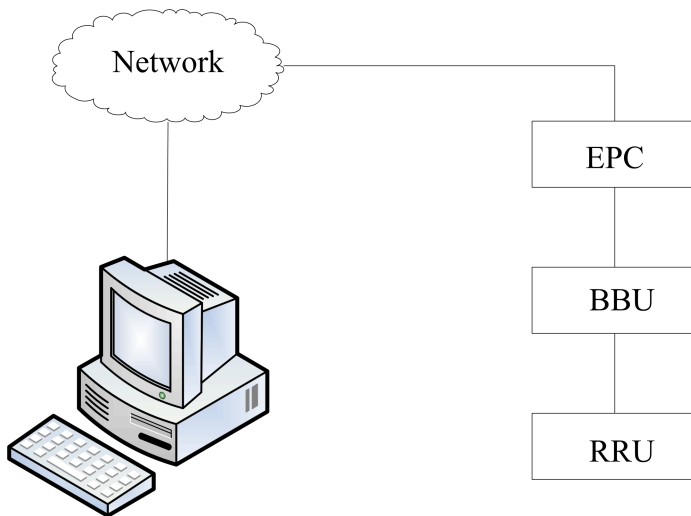

Chapter 3

Technical Specification

Table of Contents

Dimension and Weight	3-1
System Indices	3-1
Power Supply	3-2
Grounding Index.....	3-2
Power Consumption	3-2
Reliability.....	3-2
Working Environment	3-3

3.1 Dimension and Weight

Table 3-1 lists the dimension and weight of ZXSDR R8964.

Table 3-1 Dimension and Weight

Item	Index
Dimensions	440 mm x 290 mm x 134 mm (H x W x D)
Weight	17 kg
Color	light gray

3.2 System Indices

Table 3-2 lists the capacity specification of ZXSDR R8964.

Table 3-2 Device Capacity Index

Item	Index
Maximum output power	S3500 : <ul style="list-style-type: none">● 4 x 15 W @ DL:UL=2:2● 4 x 10 W @DL:UL=3:1 S2300/S2600 : <ul style="list-style-type: none">● 4 x 20 W S3600 : <ul style="list-style-type: none">● 4 x 10 W @ DL:UL=3:1

Item	Index
Frequency band	<ul style="list-style-type: none"> ● 2300 MHz ~ 2400 MHz ● 2496 MHz ~ 2690 MHz ● 3400 MHz ~ 3600 MHz (S3500) ● 3600 MHz ~ 3700 MHz (S3600)
Channel raster	100 KHz
Channel bandwidth	10 MHz, 20 MHz
Physical Interfaces	<ul style="list-style-type: none"> ● 2 optical interfaces ● 4 antenna interfaces ● 1 power interface ● 1 LMT Ethernet interface ● 1 AISG /dry contact interface
Antenna type	4-antenna
Protection	IP 65

3.3 Power Supply

ZXSDR R8964 supports -48V DC (-57V DC~-37V DC) power input.

3.4 Grounding Index

The grounding requirements of ZXSDR R8964 should be less than or equal to 5 Ω . The grounding resistance can be less than 10 Ω in the areas where the number of thunderstorm days is less than 20 a year.

3.5 Power Consumption

ZXSDR R8964 S3500 Typical Power Consumption:

- 270 W : (4*10 W @DL : UL= 3:1) .
- 240 W : (4*15 W @DL : UL=2:2) .

ZXSDR R8964 S2300/S2600 Typical Power Consumption:

- 170 W : (DL: UL= 2:2) .
- 260 W : (DL: UL= 3:1) .

ZXSDR R8964 S3600 Typical Power Consumption:

- 260 W : (4*10 W @DL : UL= 3:1)

3.6 Reliability

Table 3-3 lists the reliability index of ZXSDR R8964.

Table 3-3 Device Reliability

Item	Index
MTBF	> 180,000 hours
MTTR	<60 minutes
System service interruption time	< 3 minutes/year
Availability	99.9994%

3.7 Working Environment

Table 3-4 describes the temperature and humidity requirements of ZXSDR R8964.

Table 3-4 Temperature and Humidity Requirements

Work Environment	Regular Use in Place without Climatic Protection (Outdoor) 4K4/4Z5/4Z7/4B1/4C2/4S3/4M5
Environment Requirement	4B1
Chemical Environment	4C2
Storage temperature	-55°C to +70°C
Normal operating humidity	4% to 100%
Storage humidity	10% to 100%
Lower Temperature	-40°C
Upper Temperature	+50°C
Temperature Change rate	0.5°C/min
Air Pressure	70~106 kPa
Solar radiation	1120 W/m ²
Gel conditions	Yes

This page intentionally left blank.

Chapter 4

Product Description

Table of Contents

Device Interfaces4-1

Indicator Description.....4-2

Cables.....4-4

4.1 Device Interfaces

The external interfaces of ZXSDR R8964 are shown in Figure 4-1 and Figure 4-2.

Figure 4-1 External Interfaces 1

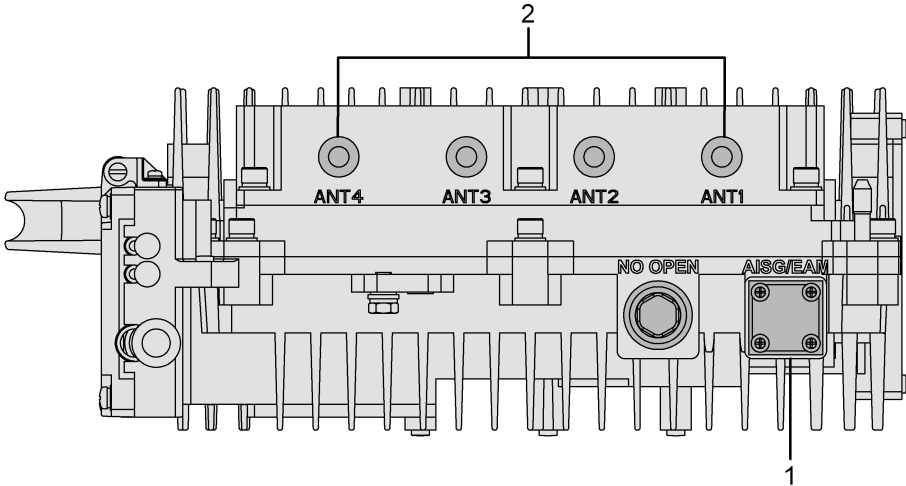
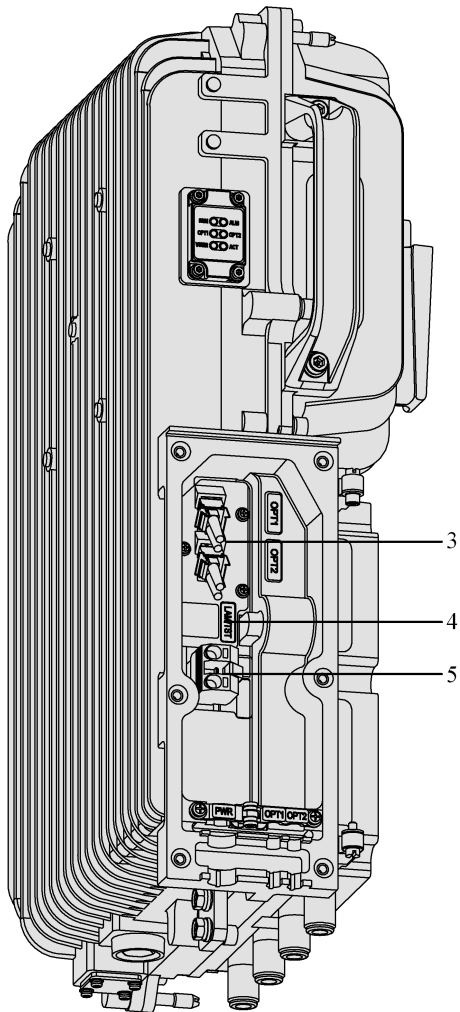

Figure 4-2 External Interfaces 2



- | | | |
|--|--------------------------------|-----------------------------|
| 1. AISG standard interface and dry contact input | 3. Optical interfaces | 5. -48 V DC power interface |
| 2. Antenna interfaces | 4. Local maintenance interface | |

4.2 Indicator Description

ZXSDR R8964 cabinet indicators are shown in [Figure 4-3](#).

Figure 4-3 ZXSDR R8964 Indicators

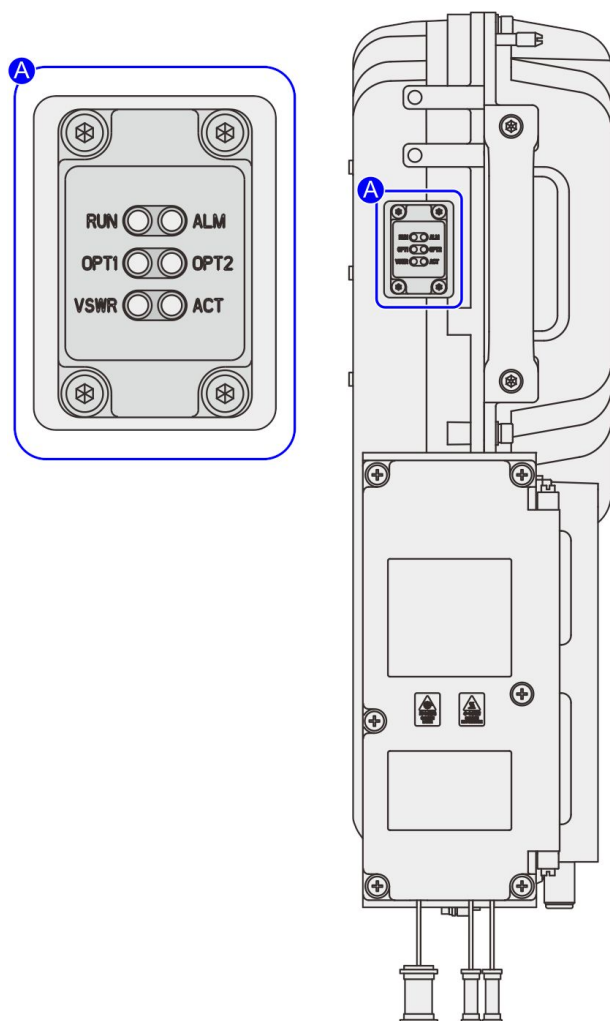

Indicators descriptions are shown in [Table 4-1](#).

Table 4-1 Indicator Descriptions

Indicator	Color	Status
RUN	Green	<ul style="list-style-type: none"> ● OFF: Indicates power off or the RRH is in fault state. ● ON: Indicates power on but the RRH is in fault state. ● Slow blinking (1.5s on, 1.5s off): Indicates that it is in the initialization process. ● Fast blinking (0.07s on, 0.07s off): Indicates that the RUDP (TCP) is not established. ● Normal blinking (0.3s on, 0.3s off): Indicates that the RRH is running normally.
ALM	Red	<ul style="list-style-type: none"> ● OFF: No Alarm(not including VSWR,OPT alarm) ● ON: Alarm(not including VSWR,OPT alarm)

Indicator	Color	Status
OPT1~OPT2	Green	<ul style="list-style-type: none"> ● OFF: The optical module has not received optical signal, or optical module is not existed etc. ● ON: The optical module has received optical signal, but optical link is not established. ● Blinking (0.3s on, 0.3s off): The optical link is established.
VSWR	Red	<ul style="list-style-type: none"> ● OFF: No VSWR Alarm ● ON: VSWR Alarm
ACT	Green	<ul style="list-style-type: none"> ● OFF: Cell is not established. ● ON: Cell is established.

4.3 Cables

4.3.1 Power Cable

ZXSDR R8964 adopts -48 V DC power input.

The DC power supply cable appearance is shown in [Figure 4-4](#).

Figure 4-4 DC Power Cable Appearance

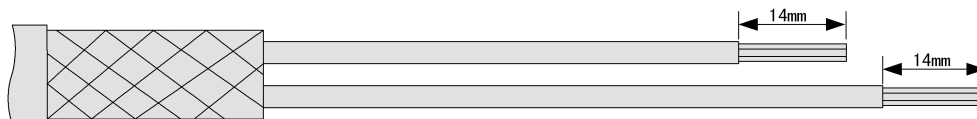

4.3.2 PE Cable

The PE cables of ZXSDR R8964 is made of 16 mm² yellow-green wires. The two ends of the wires are crimped to naked round terminals.

PE cable is shown in [Figure 4-5](#).

Figure 4-5 PE Cable

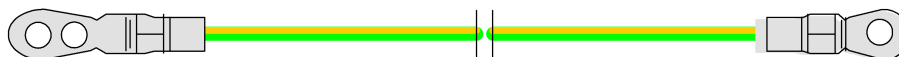

4.3.3 Optical Fiber

Optical fiber is used to connect BBU and ZXSDR R8964, as shown in [Figure 4-6](#).

Figure 4-6 Optical Fiber Cable



4.3.4 Antenna Jumper Cable

Antenna jumper cable is used to connect ZXSDR R8964 and the main feeder, the main feeder and the antenna. When the main feeder uses 7/8" or 5/4" coax cable, an antenna jumper cable is used to transit.

The appearance of the antenna jumper cable is shown in [Figure 4-7](#).

Figure 4-7 Appearance of Antenna Jumper Cable



Note:

The length of the jumper cable is decided according to the on-site situation.

4.3.5 AISG Cable

AISG is used to control the electrical-adjustment antenna. [Figure 4-8](#) shows the structure of AISG cable.

Figure 4-8 AISG Cable

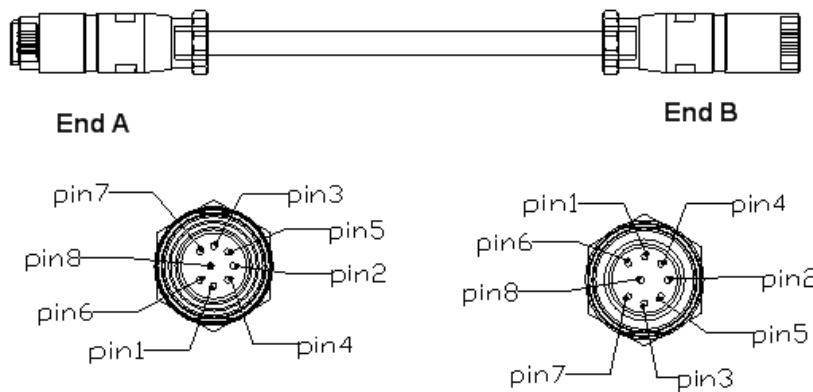

[Table 4-2](#) describes the meaning of sequence number of AISG cable.

Table 4-2 Meaning of Sequence Number of AISG Control Cable

Pins at end A	Pins at End B	Name	Meaning
PIN3	PIN1	RS485B_AISG	RS485-
PIN5	PIN2	RS485A_AISG	RS485+
PIN6	PIN3, PIN4	DC_AISG	DC power

Pins at end A	Pins at End B	Name	Meaning
PIN7	PIN5, PIN6	DC_Return_AISG	DC RTN
PIN2	PIN7	Dry_Node_In 1-	Dry contact input, negative
PIN8	PIN8	Dry_Node_In 1+	Dry contact input, positive

**Note:**

AISG cable is used only when AISG function is available.

Chapter 5

Product Maintenance

Table of Contents

Replacing Power Cable	5-1
Replacing PE Cable	5-2
Replacing Optical Fiber	5-2
Replacing Antenna Feeder Jumper	5-3

5.1 Replacing Power Cable

Prerequisite

Make sure that the type of the new power cable is the same as that of the original power cable, and their lengths must be the same.

Make sure to turn off the power supply when replacing the power cable, and to prevent user services from being affected, commit replacing procedure during appropriate period.

Steps

1. Turn off the main switch for the ZXSDR R8964.
2. Cut off the cable tie of RRU input power cable.
3. Unscrew the screw cap of the power cable from RRU power module and then remove the cable.
4. Unscrew the screw cap of the power cable from [APM/DPM](#) and then remove the cable.
5. Take out the old cable.
6. Lay the new power cable according to the cabling of the old power cable.
7. Connect the cable to the power module and [APM/DPM](#), and then fasten the bolt.
8. Make cables neat and then bundle the cables.
9. Properly handle the replaced power cable, and clean up the field.
10. Make sure that the connection is correct and reliable and then switch on the main switch of the ZXSDR R8964 for test.

– End of Steps –

5.2 Replacing PE Cable

Prerequisite

Make sure that the length of the new PE cable is the same as that of the old grounding cable.

Make sure that services are not affected during the replacement.

Context

The basic grounding net project and tower of the grounding system, the grounding project of the building, and connection points of the indoor/outdoor copper ground bar are constructed by customers. The field engineering personnel need to install the protection earth (PE) cable to the cabinet shell of the ZXSDR R8964.

Steps

1. Loosen screws on the two ends of the PE cable and then remove the cable.
2. Crimp the copper lug of one end of the PE cable to the protection grounding terminal of the ZXSDR R8964 cabinet.
3. Crimp the copper lug of the other end of the PE cable to the grounding bar.
4. Use multimeter to test the grounding resistance. The joint grounding resistance must be less than 5 ohms.
5. Clean up the field.

– End of Steps –

5.3 Replacing Optical Fiber

Prerequisite

- Perform fault observation and analysis to confirm that the optical fiber should be replaced.
- Select the optical fiber with the proper length, and check whether the type of the new optical fiber is the same as that of the old optical fiber to be replaced.
- Record the connection position of the optical fiber to be replaced, the new optical fiber should be connected at the original position.
- Prepare the moisture-proof bag and certain labels for marking.

Context

When replacing an optical fiber, pay attention to the following:

- During operations, do not damage the optical fiber cladding.
- Protect optical fiber connectors to avoid contaminating them.
- Do not forcibly pull out the original optical fiber or forcibly bundle the new optical fiber.

- Bend the new optical fiber at the turning.

Steps

1. After the old optical fiber is removed, put the protective cap on the optical port so as to avoid contaminating the optical port.
2. Cut off the cable tie of the old optical fiber, remove the old optical fiber, and then put the fiber to the moisture-proof bag.
3. Lay the new optical fiber the same path with the old one, fasten fiber connector, and then attach label on the new optical fiber.
4. Bundle the new optical fiber.

– End of Steps –

5.4 Replacing Antenna Feeder Jumper

Prerequisite

Prepare new feeder cable the same length and type as the one to be replaced.

Context

The jumper of the antenna feeder is used to induct the RF signal to RRU and connect the feeder cable of the antenna feeder system.

Steps

1. Switch off power supply.
2. Dismantle the older jumper to be replaced.
3. Connect one end of the feeder jumper to the feeder system, and then connect the other end of the feeder jumper to antenna port of RRU.
4. Switch on power supply.

– End of Steps –

This page intentionally left blank.

Glossary

AISG

- Antenna Interface Standards Group

APM

- AC Protection Module

BBU

- Baseband Unit

DPM

- DC Protection Module

IP

- Internet Protocol

LMT

- Local Maintenance Terminal

LTE

- Long Term Evolution

MIMO

- Multiple-Input Multiple-Output

MTBF

- Mean Time Between Failures

MTTR

- Mean Time To Repair

NE

- Network Element

RF

- Radio Frequency

RRU

- Remote Radio Unit

SDR

- Software Defined Radio

TCP

- Transmission Control Protocol

eNodeB

- Evolved NodeB