



# **ZXSDR RSUC**

## **Radio System Unit of CDMA with 1T2R**

### **User Manual**

---

Version V1.00

ZTE CORPORATION  
NO. 55, Hi-tech Road South, ShenZhen, P.R.China  
Postcode: 518057  
Tel: (86) 755 26771900  
Fax: (86) 755 26770801  
URL: <http://ensupport.zte.com.cn>  
E-mail: [support@zte.com.cn](mailto:support@zte.com.cn)

## LEGAL INFORMATION

Copyright © 2010 ZTE CORPORATION.

The contents of this document are protected by copyright laws and international treaties. Any reproduction or distribution of this document or any portion of this document, in any form by any means, without the prior written consent of ZTE CORPORATION is prohibited. Additionally, the contents of this document are protected by contractual confidentiality obligations.

All company, brand and product names are trade or service marks, or registered trade or service marks, of ZTE CORPORATION or of their respective owners.

This document is provided "as is", and all express, implied, or statutory warranties, representations or conditions are disclaimed, including without limitation any implied warranty of merchantability, fitness for a particular purpose, title or non-infringement. ZTE CORPORATION and its licensors shall not be liable for damages resulting from the use of or reliance on the information contained herein.

ZTE CORPORATION or its licensors may have current or pending intellectual property rights or applications covering the subject matter of this document. Except as expressly provided in any written license between ZTE CORPORATION and its licensee, the user of this document shall not acquire any license to the subject matter herein.

ZTE CORPORATION reserves the right to upgrade or make technical change to this product without further notice.

Users may visit ZTE technical support website <http://ensupport.zte.com.cn> to inquire related information.

The ultimate right to interpret this product resides in ZTE CORPORATION.

### **Revision History**

<b>Revision No.</b>	<b>Revision Date</b>	<b>Revision Reason</b>
25/10/2010	25/05/2010	R1.0

Serial Number: SJ-20101019140047-002

# FCC & IC STATEMENT

---

This device complies with Part 15 of the FCC Rules. Operation is subject to the following two conditions: (1) this device may not cause harmful interference, **and** (2) this device must accept any interference received, including interference that may cause undesired operation.

---

 **Note:**

This equipment has been tested and found to comply with the limits for a Class A digital device, pursuant to Part 15 of the FCC Rules. These limits are designed to provide reasonable protection against harmful interference when the equipment is operated in a commercial environment. This equipment generates, uses, and can radiate radio frequency energy and, if not installed and used in accordance with the instruction manual, may cause harmful interference to radio communications.

---

Operation of this equipment in a residential area is likely to cause harmful interference in which case the user will be required to correct the interference at his own expense.

This page is intentionally blank.

# Declaration of RoHS Compliance

---

To minimize the environmental impact and take more responsibility to the earth we live, this document shall serve as formal declaration that ZXSDR RSUC manufactured by ZTE CORPORATION are in compliance with the Directive 2002/95/EC of the European Parliament - RoHS (Restriction of Hazardous Substances) with respect to the following substances:

- Lead (Pb)
- Mercury (Hg)
- Cadmium (Cd)
- Hexavalent Chromium (Cr (VI))
- PolyBrominated Biphenyls (PBB's)
- PolyBrominated Diphenyl Ethers (PBDE's)

...

The ZXSDR RSUC manufactured by ZTE CORPORATION meet the requirements of EU 2002/95/EC; however, some assemblies are customized to client specifications. Addition of specialized, customer-specified materials or processes which do not meet the requirements of EU 2002/95/EC may negate RoHS compliance of the assembly. To guarantee compliance of the assembly, the need for compliant product must be communicated to ZTE CORPORATION in written form. This declaration is issued based on our current level of knowledge. Since conditions of use are outside our control, ZTE CORPORATION makes no warranties, express or implied, and assumes no liability in connection with the use of this information.

This page is intentionally blank.

# Chapter 1

## Safety Description

---

### Table of Contents

Safety Specifications Guide .....	1
Safety Symbols .....	2
Safety Instructions .....	3

## Safety Specifications Guide

These safety instructions must be considered as supplementary for local safety regulations. The priority must be given to local safety regulations if there is any conflict between the two.

The maintenance personnel must have the knowledge of safety operations and maintenance with required qualification and technical background.



### Warning:

This device complies with part 15 of the FCC Rules. Operation is subject to the following two conditions:

- This device may not cause harmful interference.
- This device must accept any interference received, including interference that may cause undesired operation.

Changes or modifications not expressly approved by the party responsible for compliance could void the user's authority to operate the equipment.

The equipment is intended for installation in RESTRICTED ACCESS LOCATIONS.

---

All the operation and maintenance personnel must follow the safety precautions and instructions provided by ZTE Corporation to avoid any accident.

 **Note:**

ZTE Corporation does not bear any liabilities incurred because of violation of the universal safety operation requirements, or violation of safety standards for designing, manufacturing and using the equipment.







**FCC Radiation Exposure Statement:**

This equipment complies with FCC radiation exposure limits set forth for an uncontrolled environment. This equipment should be installed and operated with minimum distance 4m between the radiator & your body.



## Safety Symbols

[Table 1](#) lists safety symbols. They are to prompt the user of the safety precautions to be observed during ZXSDR RSUC operation and maintenance.

**TABLE 1 SAFETY SYMBOLS DESCRIPTION**

Safety Symbols	Meaning
	No smoking: Smoking is forbidden
	No flammables: No flammables can be stored.
	No touching: Do not touch.
	Universal alerting symbol: General safety attentions.
	Electric shock: Risk of electric shock.
	Electrostatic: The device may be sensitive to static electricity.
	Microwave: Beware of strong electromagnetic field.



Safety Symbols	Meaning
	Laser: Beware of strong laser beam.
	Scald: Beware of scald.

Amongst these safety symbols, the universal alarm symbols are classified into three levels: danger, warning, and caution. The formats and meanings of the three levels are described as below:



#### **Danger:**

Indicates a potentially hazardous situation which, if not avoided, will result in death or serious injury of people, or equipment damages and breakdown.



#### **Warning:**

Indicates a potentially hazardous situation which, if not avoided, could result in death or serious injury.



#### **Caution:**

Indicates a potentially hazardous situation which, if not avoided, could result in serious injuries, equipment damages or interruption of part services.

## Safety Instructions

This section describes the safety instructions related to electrical safety, antistatic, heavy objects and modules.

### **Electrical Safety Instructions**

The following are the electrical safety instructions about tools, high voltage, power cables, holes and lightning:

- **Tools**

Use special tools rather than common tools for high-voltage and AC operations.

- **High Voltage**

**Danger:**

High voltage is hazardous. Direct or indirect contact with high voltage or main supply using a wet object could result in death.

- ▶ Strictly follow local safety rules to install AC power devices.
- ▶ Installation staff must be qualified for performing high-voltage and AC operations.
- ▶ Do not wear any watch, hand chain, bracelet, ring or any other conductive objects during such operations.
- ▶ Prevent moisture from accumulating on the equipment during operations in a damp environment.

**■ Power Cable****Warning:**

Never install or uninstall power cables while they are live. Otherwise, the power cable, when contacting a conductor, may result in sparks or electric arc causing a fire or even damage to eyes.

- ▶ Make sure of shutting off power supply before installing or disconnecting a power cable.
- ▶ Before connecting the power cable, make sure that the connecting cable and its label are appropriate for the actual installation requirements.

**■ Drilling Holes****Warning:**

It is not allowed to drill chassis holes without permission.

- ▶ Unqualified drilling could damage wiring and cables inside the chassis. Additionally, metal pieces inside the chassis created by the drilling could result in a short circuit. Use insulation protection gloves and first move cables inside a chassis away when drilling is necessary on a chassis.
- ▶ Protect eyes during drilling as dust or flying debris may damage eyes.
- ▶ Clean any debris in time after drilling.

**■ Lightning****Danger:**

Do not perform high-voltage, AC, iron tower or mast operations in a thunderstorm.

---

Thunderstorms would give rise to a strong electromagnetic field in the atmosphere. Therefore, the equipment must be grounded and protected in time against lightning strikes.

### Antistatic Safety Instructions



#### Electrostatic:

Static electricity produced by human body can damage static-sensitive components on circuit board, such as large-scale integrated circuits.

- Friction caused by human body activities is the root cause of electrostatic charge accumulation. Static voltage carried by a human body in a dry environment can be up to 30 kV, and can remain there for a long time. An operator with static electricity may discharge electricity through a component when he/she touches the conductor and causing damage.
- Wear an antistatic wrist strap (the other end of wrist strap must be well grounded) before touching the equipment or holding a plug-in board, circuit board, Integrated Circuit (IC) chip or other devices, to prevent human static electricity from damaging sensitive components.
- The antistatic wrist strap used must be subject to regular check. Do not replace the cable of an antistatic wrist strap with any other cables.
- Do not contact static-sensitive modules with any object that easily generates static electricity. For example, friction of package bag, transfer box and transfer belt made from insulation plastic may cause static electricity on components. Discharge of static electricity may damage components when they contact a human body or the ground.
- Modules should only contact materials such as an antistatic bag. Keep modules in antistatic bags during storage and transportation.
- Discharge static electricity of the test device before use, that is, ground the test device first.
- Do not place the module near a strong DC magnetic field, such as the cathode-ray tube of a monitor. Keep the module at least 10 cm away.

### Hoisting Heavy Objects



#### Warning:

When hoisting heavy objects, ensure that nobody is standing or walking under the hoisted object.

- Ensure the hoister can meet hoisting requirements when disassembling heavy equipment, or moving and replacing equipment.
- The installation personnel must be duly trained and qualified for hoisting operations.
- Hoisting tools must be inspected and complete before service.

**Unplugging/Plugging a Module**

- Make sure that hoisting tools are fixed firmly on a sufficiently secured object or wall before the hoisting operation.
- Give brief oral instructions during hoisting operations to prevent any mishap.
- Never plug a module with excessive force, to ensure that the pins on the backplane do not get deformed.
- Plug the module right into the slot and make sure module circuit faces do not contact each other lest any short circuit may occur.
- Keep hands off the module circuit, components, connectors and cable trough when holding a module.

**Rack Mount Safety Instructions**

Rack Mount Instructions - The following or similar rack-mount instructions are included with the installation instructions:

- Elevated Operating Ambient - If installed in a closed or multi-unit rack assembly, the operating ambient temperature of the rack environment may be greater than room ambient. Therefore, consideration should be given to installing the equipment in an environment compatible with the maximum ambient temperature (T<sub>ma</sub>) specified by the manufacturer.
- Reduced Air Flow - Installation of the equipment in a rack should be such that the amount of air flow required for safe operation of the equipment is not compromised.
- Mechanical Loading - Mounting of the equipment in the rack should be such that a hazardous condition is not achieved due to uneven mechanical loading.
- Circuit Overloading - Consideration should be given to the connection of the equipment to the supply circuit and the effect that overloading of the circuits might have on overcurrent protection and supply wiring. Appropriate consideration of equipment nameplate ratings should be used when addressing this concern.
- Reliable Earthing - Reliable earthing of rack-mounted equipment should be maintained. Particular attention should be given to supply connections other than direct connections to the branch circuit (e.g. use of power strips).

**Other Safety Instructions****Note:**

Do not perform maintenance or debugging independently, unless a qualified person is present.

- Perform an airtight test before RRU delivery, and prohibit disassembling the RRU on site.
- Replacing any parts or making any changes to the equipment might result in an unexpected danger. Therefore, be sure not to replace any parts or perform any changes to the equipment unless authorized otherwise.
- Due to that RRU is in high temperature during running, the RRU should be installed in some regions out of operators' reach or strictly restricted.

- Contact ZTE office if you have any question, to ensure your safety.

This page is intentionally blank.

## Chapter 2

# Product Description

---

### Table of Contents

Overview.....	9
Position in a Network .....	9
Outer View .....	10
Production Functions.....	11
Production Features .....	12

## Overview

ZTE Software Defined Radio (SDR) uses an architecture of separating the baseband part from the Radio Frequency (RF) part. This architecture features high integration, low consumption, flexible configuration and convenient installation & maintenance. The new generation ZTE CDMA Base Station (BS) products based on the SDR is the first SDR-based CDMA BS in the industry. It is able to help the operators have qualitative leap. The form of this product can be distributed BBU + RRU or BBU + RSU. The product form of ZTE SDR can be distributed BBU + RRU or BBU + RSU, macro BS or micro BS.

ZXSDR RSUC is the RSU part of ZTE CDMA2000 distributed SDR Common BTS Platform Solution. It provides functions including RF modulation/demodulation, forward power amplification, reverse low noise amplification, RF performance measurement and carrier power control etc.

With a smaller size and lighter weight, the ZXSDR RSUC has significant advantages for saving space, relocations, installation flexibility, and power savings. It designed for both indoor and outdoor applications.

## Position in a Network

In CDMA mobile communication network, the relationship between ZXSDR RSUC and other network entities is shown in [Figure 1](#).

FIGURE 1 ZXSDR RSUC POSITION IN A NETWORK

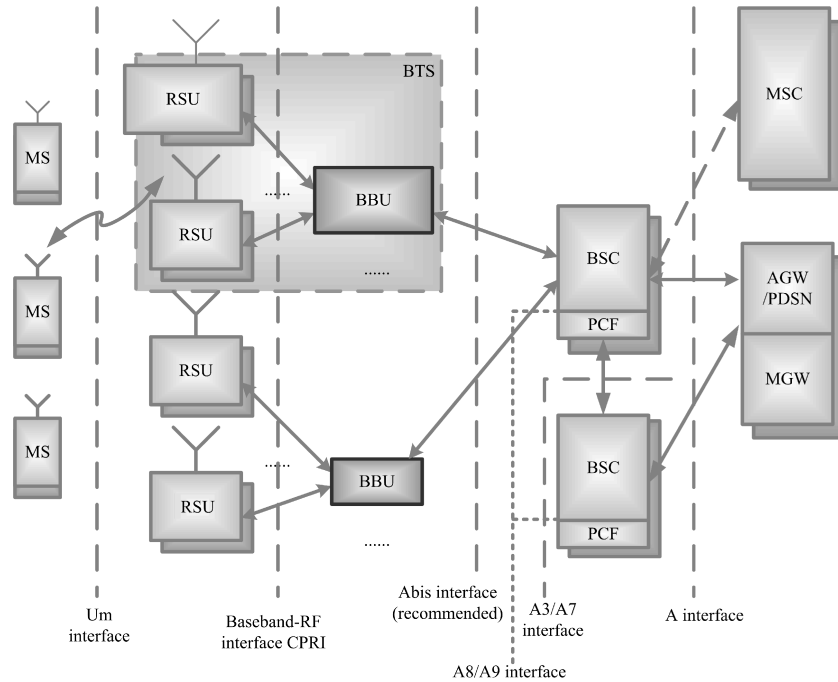

The ZXSDR RSUC is an independent RF subsystem. Together with BBU, it forms the complete BTS. The BTS implements radio transmission with the MS through the CDMA2000 air interface. In addition, the BTS implements control of radio channels and communication with the BSC.

## Outer View

[Figure 2](#) shows the outer view of ZXSDR RSUC.



FIGURE 2 OUTER VIEW OF ZXSDR RSUC



## Production Functions

ZXSDR RSUC provides primary functions is shown as [Table 2](#).

TABLE 2 THE PRIMARY FUNCTIONS OF ZXSDR RSUC

Function	Description
RF	Band: 800MHz、1.9GHz、2.1GHz、2.0GHz(AWS)、450MHz、420MHz、850MHz
	RF modulation/demodulation
	RF transceiver duplexer
	Low noise amplification for received RF signal
	Amplification for transmitted RF signal
	RF transceiver
Interface	Baseband-RF interface: compliant with Common Public Radio Interface (CPRI) protocol
	Air interface: compliant with IS-2000 Release A and IS-856-A
Equipment maintenance and test	Electronic label
	Remote upgrade of software version for FPGA/BOOT/DSP/CPU
	Remote reset of service boards
	RSSI query
	Automatic calibration
	Reverse spectrum query: querying the reverse received signal spectrum of each carrier
	Power amplification control and protection: over-power, over-temperature, and standing wave alarm
Reliability	Reverse voltage protection
Scenario	Indoor and outdoor applications

## Production Features

Here are the product features of ZXSDR RSUC :

- Easy transportation and installation will save labor and building costs
  - Lower power consumption reduces installation of power expenditures and saves on electricity charges.
  - Suitable for complicated base station environments
- Supports star and chain networks between baseband and RF to provide more convenient solutions for complicated base station environments.

# Chapter 3

## Technical Description

### Table of Contents

System Architecture .....	13
Signal Processing Flow .....	14
Technical Specifications .....	14

## System Architecture

A ZXSDR RSUC consists of the transmit/receive signal board (RTR), power amplifier (PA), duplexer (DFL), and power supply (RPDC). [Figure 3](#) shows the schematic diagram of the ZXSDR RSUC.

**FIGURE 3 SCHEMATIC DIAGRAM OF THE ZXSDR RSUC**

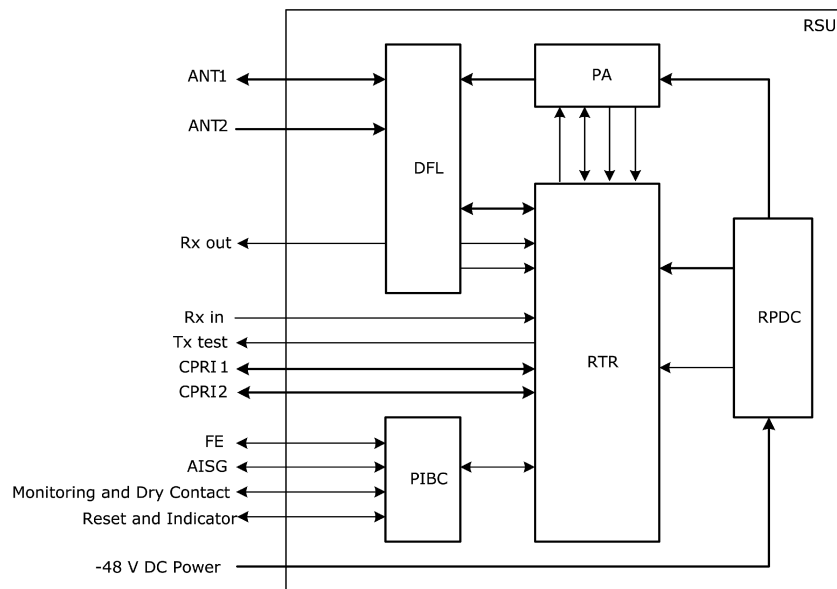

The functions of ZXSDR RSUC's subsystem is shown as [Table 3](#).

TABLE 3 THE FUNCTIONS OF SUBSYSTEM

Part	Description
RTR	RTR, the unit that integrates the processor, clock, CPRI interface, DPD digital predistortion, RF transmitting and receiving functions, is the core unit of the ZXSDR RSUC.
PA	<ul style="list-style-type: none"> <li>▪ Amplifies downlink RF signal input via the RTR and then sends the signal to the DFL</li> <li>▪ Provides digital pre-distortion feedback signals for the RTR</li> <li>▪ Provides a PA output enable/disable interface</li> </ul>
DFL	<ul style="list-style-type: none"> <li>▪ Performs filtering and low noise amplification of the reverse CDMA signal from the antenna</li> <li>▪ Filters the forward RF signal to be sent</li> <li>▪ Reports LNA alarms to the RTR</li> <li>▪ In the case of main/diversity combined cabinets, the main receive LNA output end of the DFL has the power splitter function and reserves an external port (Rx out)</li> </ul>
RPDC	Converts -48V DC input power supply to DC power supply required by the PA, RTR, or DFL

## Signal Processing Flow

The internal signal processing flow of ZXSDR RSUC is as below:

- Forwardlink processing  
The business data from BBU enters the RTR, and then for intermediate frequency processing. After the power amplification sent to the antenna for transmission.
- Reverselink processing  
The reverse CDMA signals from the antenna are converted to baseband digital signal by RTR, then send to BBU.

## Technical Specifications

### Physical Indices

---

#### Dimension

The dimensions of ZXSDR RSUC in mm are : 482.6(H) × 88 (W) × 360.0 (D).

## Weight

Weight of a ZXSDR RSUC : < 10 kg (22.05 pounds).

## Power Indices

---

- Power Supply  
-48V DC Voltage range: -37V~-62V.
- Power Consumption  
In the case of 1S-1T, 4C/S, 15W/C, the total power consumption of the equipment is 270 W.

## Capacity Indices

---

ZXSDR RSUC Capacity Indices is shown as [Table 4](#)

**TABLE 4 ZXSDR RSUC CAPACITY INDICES**

Item	Carriers supported
1	8C 1X
2	4C 1X + 4C DO
3	the MAX 8C/1S-1T

## Temperature and Humidity

---

Temperature: -40 °C~+55 °C. The change frequency must be less than 0.5 °C/min.

Relative humidity: 5% ~95%

## Environmental Classes

---

- Grade Of Protection: IP55
- Grounding Requirements: Joint grounding resistance less 1W; BTS grounding resistance less 5 W.
- Noise: Noise of working environment: less 65 dBA

## Reliability Indices

- Mean Time Between Failures (MTBF) : > 100,000 hours
- MTTR (Mean Time To Repair): < 0.5 hour
- Availability: > 99.999%

## RF Indices

RF indices of the ZXSDR RSUC comply with 3GPP2 C.S0010-C, Recommended Minimum Performance Standards for cdma2000 Spread Spectrum Base Station and 3GPP2 C.S0032-A, Recommended Minimum Performance Standards for CDMA2000 High Rate Packet Data Access Network.

[Table 5](#) illustrates the 800 MHz transmitter indices.

**TABLE 5 800 MHz TRANSMITTER INDICES**

Name	Index
Operating band	800 MHz (Band Class 0)
Transmitter output frequency tolerance	$\pm 0.01$ ppm
Occupied channel bandwidth	1.23 MHz (Band Class 0)
Output power at the Top of Cabinet (TOC)	60W
Total transmit power	The total transmit power is within +2 dB and -2 dB of the manufacturer's rated power.
Modulation mode	Quadrature amplitude modulation
Conducted spurious emission and radiated spurious emission suppression	<p>&lt; -45dBc @<math>\pm 750</math>kHz offset Center Freq (RBW 30kHz)</p> <p>&lt; -60dBc @<math>\pm 1.98</math>MHz offset Center Freq(RBW 30kHz)</p> <p>&gt;4MHz OFFSET:</p> <p>&lt; -36dBm(RBW 1kHz) @ 9kHz &lt; f &lt; 150kHz</p> <p>&lt; -36dBm(RBW 10kHz) @ 150kHz &lt; f &lt; 30MHz</p> <p>&lt; -30dBm(RBW 1MHz) @ 1GHz &lt; f &lt; 12.5GHz</p> <p>4-6.4MHz OFFSET:</p> <p>&lt; -36dBm(RBW 1kHz) @ 30MHz &lt; f &lt; 1GHz</p> <p>6.4M TO 16M OFFSET:</p> <p>&lt; -36dBm(RBW 10kHz) @ 30MHz &lt; f &lt; 1GHz</p> <p>&gt;16MHz OFFSET:</p> <p>&lt; -36dBm(RBW 100kHz) @ 30MHz &lt; f &lt;</p>

Name	Index
	1GHz
Transmitter intermodulation performance	If one BTS transmits at the rated power but another BTS' output power is 30 dB less than the former's rated power. When the powers of two BTSs are combined on the antenna port, the generated intermodulation spurious emission meets the conducted spurious emission requirement. The IF difference of the transmit signals of two BTSs is 1.25M.
Pilot time tolerance	The PN time tolerance falls within 3 us and the inter-carrier tolerance falls within 1 us.
Time Tolerance/phase tolerance of pilot channel to other channels	Time difference: < $\pm 50$ ns
	Phase difference: < 0.05 rad
Waveform quality	Rho is greater than 0.970 dBm with configuration of a single pilot.
Pilot code domain power	With the standard 9CH configuration, the pilot code domain power is in the range of $-7.0 \pm 0.5$ dB.
Inactive channel code domain power	With the standard 9CH configuration, the inactive channel code domain power is less than -27 dB.
DO MAC inactive channel code domain power	With configuration of 13 FLUSs, the MAC inactive channel code domain power is less than -29.5 dB (type 2).
DO DATA channel code domain power	With configuration of 13 FLUSs at the rate of 614.44 kbs (test 1), the DATA channel code domain power is in the range of -15.5 dB to -14.5 dB.
Wave quality of DO channels	Pilot channel: Rho > 0.97
	MAC channel: Rho > 0.912
	DATA channel: Rho > 0.97
Radio frequency Front End SWR	< 2.0

[Table 6](#) illustrates the 1.9 GHz transmitter indices.

**TABLE 6 1.9 GHz TRANSMITTER INDICES**

Name	Index
Operating band	1.9 GHz (Band Class 1)
Transmitter output frequency tolerance	$\pm 0.01$ ppm

Name	Index
Occupied channel bandwidth	1.25 MHz
Output power at the Top of Cabinet (TOC)	60W
Total transmit power	The total transmit power is within +2 dB and -2 dB of the manufacturer's rated power.
Modulation mode	Quadrature amplitude modulation
Conducted spurious emission and radiated spurious emission suppression	<p>&lt; -45dBc @±885 kHz offset Center Freq (RBW 30kHz)</p> <p>&lt; -55 dBc @±1.98 MHz offset Center Freq (RBW 30kHz)</p> <p>&gt; 4 MHz OFFSET:</p> <p>&lt; -36 dBm (RBW 1kHz) @ 9kHz &lt; f &lt; 150 kHz</p> <p>&lt; -36 dBm (RBW 10kHz) @ 150 kHz &lt; f &lt; 30 MHz</p> <p>&lt; -36 dBm (RBW 100kHz) @ 30 MHz &lt; f &lt; 1 GHz</p> <p>4-16 MHz OFFSET:</p> <p>&lt; -30 dBm (RBW 30kHz) @ 1 GHz &lt; f &lt; 12.5 GHz</p> <p>16M-19.2M OFFSET:</p> <p>&lt;-30dBm(RBW 300kHz) @ 1GHz &lt; f &lt; 12.5GHz</p> <p>&gt;19.2MHz OFFSET:</p> <p>&lt;-30dBm(RBW 1MHz) @ 1GHz &lt; f &lt; 12.5GHz</p>
Transmitter intermodulation performance	If one BTS transmits at the rated power but another BTS' output power is 30 dB less than the former's rated power. When the powers of two BTSs are combined on the antenna port, the generated intermodulation spurious emission meets the conducted spurious emission requirement. The IF difference of the transmit signals of two BTSs is 1.25 M.
Pilot time tolerance	The PN time tolerance falls within 3 us and the inter-carrier tolerance falls within 1 us.
Time Tolerance/phase tolerance of pilot channel to other channels	Time difference: < ±50 ns
	Phase difference: < 0.05 rad
Waveform quality	Rho is greater than 0.990 dBm under the configuration of a single pilot.
Pilot code domain power	With the standard 9CH configuration, the pilot code domain power is in the range of -7.0±0.5 dB.
Inactive channel code domain power	With the standard 9CH configuration, the inactive channel code domain power is less than -27 dB.



Name	Index
DO MAC inactive channel code domain power	With configuration of 13 FLUSs, the MAC inactive channel code domain power is less than -29.5 dB (type 2).
DO DATA channel code domain power	With configuration of 13 FLUSs at the rate of 614.44 kbs (test 1), the DATA channel code domain power is in the range of -15.5 dB to -14.5 dB.
Wave quality of DO channels	Pilot channel: $\text{Rho} > 0.97$
	MAC channel: $\text{Rho} > 0.912$
	DATA channel: $\text{Rho} > 0.97$
Radio frequency Front End SWR	< 2.0

[Table 7](#) illustrates the 800 MHz receiver indices.

**TABLE 7 800 MHz RECEIVER INDICES**

Name	Index
Operating band	800 MHz (Band Class 0)
Receiver sensitivity	< -115 dBm
Receiver dynamic range	When the lower limit is the receiver sensitivity and the upper limit (noise level) equals 55 dBm/1.23MHz ( $E_b/N_0 = 10 \text{ dB} \pm 1\text{dB}$ ), the Frame Error Rate (FER) is lower than 1%.
Noise figure	< 3
Single tone desensitization	In the presence of a single tone that is 50 dB above the CDMA signal level, and is at offset of $\pm 750$ kHz from the center frequency, the output power of the MS increases by no more than 3 dB, and the FER is less than 1.5%. In the presence of a single tone that is 75 dB above the CDMA signal level, and is at offset of $\pm 900$ kHz from the center frequency, the output power of the MS increases by no more than 3 dB, and the FER is less than 1.5%.
Intermodulation spurious response attenuation	BAND 0: In the presence of two interfering tones that are 60 dB above the CDMA signal level, and are at offsets of +900 kHz, +1.7 MHz, -900 kHz and -1.7 MHz from the center frequency, the output power of the MS increases by no more than 3 dB, and the FER is less than 1.5%.
Conducted spurious	< -80 dBm, measured within the BTS

Name	Index
emissions and radiated spurious emissions	receive band < -60 dBm, measured within the BTS transmit band
Radio frequency Front End SWR	< 2.0

[Table 8](#) illustrates the 1.9 GHz receiver indices.

**TABLE 8 1.9 GHz RECEIVER INDICES**

Name	Index
Operating band	1.9G Hz (Band Class 1&14)
Receiver sensitivity	< -115 dBm
Receiver dynamic range	When the lower limit is the receiver sensitivity and the upper limit (noise level) equals - 55 dBm/1.23 MHz ( $E_b/N_0 = 10\text{dB} \pm 1\text{dB}$ ), the Frame Error Rate (FER) is lower than 1%.
Noise figure	< 3
Adjacent channel selection (ACS)	Band Class 6:> - 53dBm ( $\pm 2.5\text{M}$ )
Single tone desensitization	In the presence of a single tone that is 50 dB above the CDMA signal level, and is at offset of $\pm 750$ kHz from the center frequency, the output power of the MS increases by no more than 3 dB ,and the FER is less than 1.5%. In the presence of a single tone that is 75 dB above the CDMA signal level, and is at offset of $\pm 900$ kHz from the center frequency, the output power of the MS increases by no more than 3 dB, and the FER is less than 1.5%.
Intermodulation spurious response attenuation	In the presence of two interfering tones that are 60 dB above the CDMA signal level, and are at offsets of 1.25 MHz and 2.05 MHz, and -1.25 MHz and -2.05 MHz from the center frequency, the output power of the MS increases by no more than 3 dB, and the FER is less than 1.5%.
Conducted spurious emissions and radiated spurious emissions	< -80 dBm, measured within the BTS receive band < -60 dBm, measured within the BTS transmit band
Radio frequency Front End SWR	< 2.0

## Interface Indices

---

The interface indices of ZXSDR RSUC is shown as [Table 9](#).

**TABLE 9 DESCRIPTION OF ZXSDR RSUC'S INTERFACES**

Type	Description	Index
CPRI	Fiber/Cable	2CPRI interfaces: 1 CPRI for BBU or upper-level RSU , 1 CPRI for lower-level RSU
UE	Um interface	1 Tx/Rx , 1 diversity receivers

This page is intentionally blank.

## Chapter 4

# Hardware Description

---

### Table of Contents

Function.....	23
Panel .....	23
Button .....	24
Indicators.....	25
Panel Interfaces .....	25

## Function

RSU provides the following functions:

- Communication with the baseband subrack
- Conversion between air interface RF signals and digital signals
- RF signal amplification, transmission, and reception
- Clock synchronization.

## Panel

[Figure 4](#) illustrates the ZXSDR RSUC panel.

FIGURE 4 ZXSDR RSUC PANEL

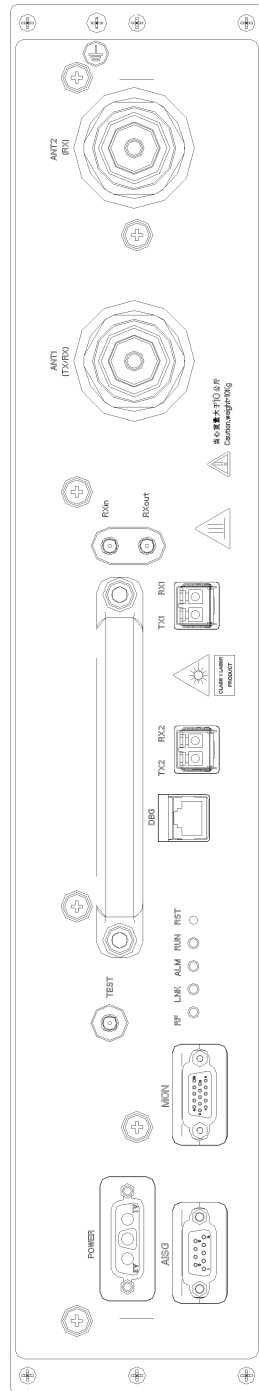

## Button

There is only one button (RST) on the ZXSDR RSUC panel. [Table 10](#) describes the button.

**TABLE 10 ZXSDR RSUC PANEL BUTTON DESCRIPTION**

Button	Description
RST	Reset button

## Indicators

[Table 11](#) describes ZXSDR RSUC panel indicators.

**TABLE 11 ZXSDR RSUC PANEL INDICATOR DESCRIPTION**

Indicator	Color	Meaning	Description
RUN	Green	Running status indicator	<p>Always on: The RSU is resetting or starting up.</p> <p>Blinking at 1 Hz: The RSU is functioning properly.</p> <p>Blinking at 5 Hz: The RSU is downloading version files.</p> <p>Off: The RSU fails the self-check.</p>
ALM	Red	Alarm indicator	<p>Off: There is on alarm or the RSU is resetting, starting up, or downloading version files.</p> <p>Blinking at 5 Hz: There is a critical alarm.</p> <p>Blinking at 1 Hz: There is a minor alarm.</p>
LNK	Green	Optical link status indicator	<p>Always on: The optical connection is normal.</p> <p>Off: The optical fiber fails.</p> <p>Blinking at 5 Hz: This link is used as the clock reference source and the phase lock loop (PLL) is in the fast capture state.</p> <p>Blinking at 0.25 Hz: This link is used as the clock reference source and the phase lock loop (PLL) is in the tracing state.</p>
RF	Orange	RF working status indicator	<p>Off: The RF has no output.</p> <p>On: The RF has output.</p>

## Panel Interfaces

[Table 12](#) describes ZXSDR RSUC panel interfaces.

**TABLE 12 INTERFACES ON THE FRONT PANEL OF THE ZXSDR RSUC**

<b>Interface</b>	<b>End A</b>	<b>End B</b>	<b>Description</b>
ANT1(TX/RX)	RSU	Tx/Rx antenna	Connects to the Tx/Rx antenna for the Tx/Rx major channel.
ANT2(RX)	RSU	Rx antenna	Connects to the antennal for the Rx minor antenna
Rx out	RSU	RSU with expanded frequency points	Frequency-point expansion output interface for outputting the Rx signals of the major channel.
Rx in	RSU with expanded frequency points	RSU	Frequency-point expansion input interface for inputting the Rx signals of the minor channel.
TX1/RX1	RSU	BBU or the upper-layer cascaded RSU	Connects to the CPRI optical interface of BBU or the upper-layer cascaded RSU
TX2/RX2	RSU	Lower-layer cascaded RSU	Connects to the CPRI optical interface of the lower-layer cascaded RSU
DBG	RSU	PC or testing equipment (with a the testing board)	Commissioning Ethernet interface and testing interface
TEST	RSU	Testing equipment	Tx testing signal interface
MON	RSU	External equipment	Provides four dry-contact input interfaces and RS-485 environment monitoring interface
AISG	RSU	Antenna	Connects to the AISG interface
POWER	RSU	RF power of the power distribution module	Power input interface



## Chapter 5

# Hardware Installation

---

### Table of Contents

Installing the RSU Module.....	27
Connecting RSU Monitoring Cable .....	35
Installing Optical Fibers Between BBU and RSU.....	36
Installing the Interconnected Cable Between BBU and RSU.....	38
Installing the RF Jumper.....	40

## Installing the RSU Module

- Prerequisites**
- Before installing the RF module, wear the ESD wrist strap to avoid damaging the RF module.
  - The RF cabinet has already been installed.
- Context** [Figure 5](#) shows the front panel of a ZXSDR RSUC.

FIGURE 5 ZXSDR RSUC PANEL

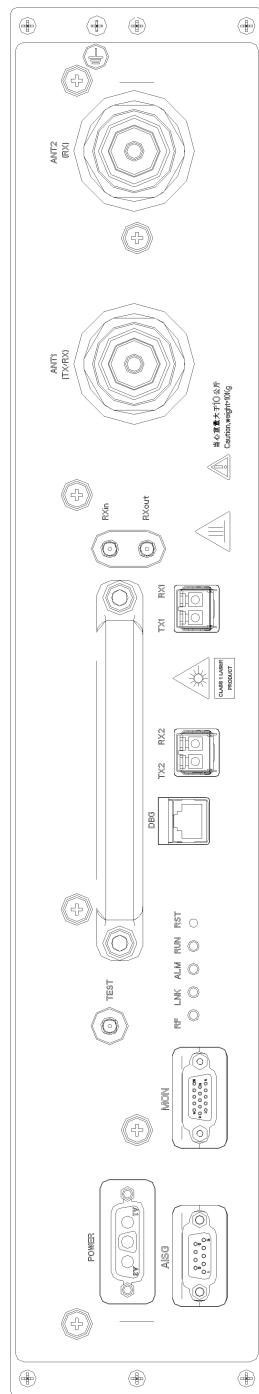

- Steps**
1. Determine the target slot, hold the handle of the module with one hand, support the lower back of the module with the other hand, and try to make parallel the module and the guiding plane, as shown in [Figure 6](#).

FIGURE 6 STEP 1

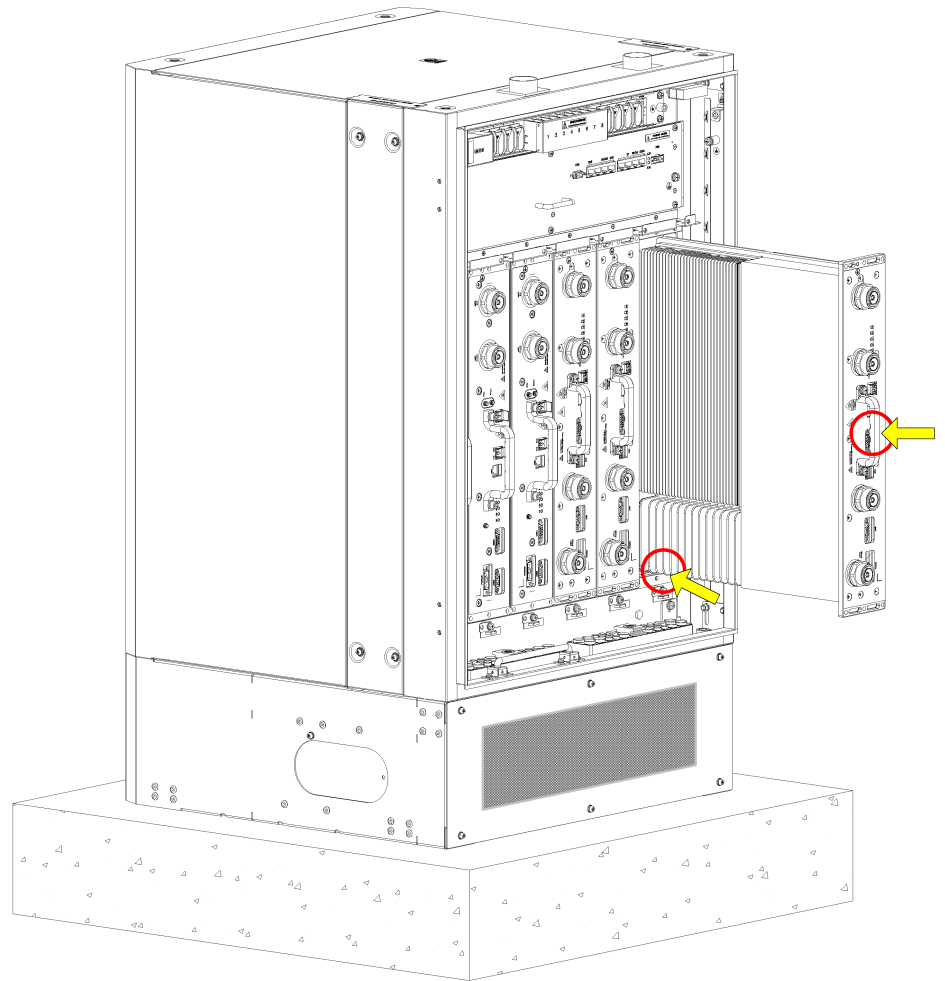

2. Push the module slightly into the slot to more than half the depth of the slot, as shown in [Figure 7](#).

FIGURE 7 STEP 2

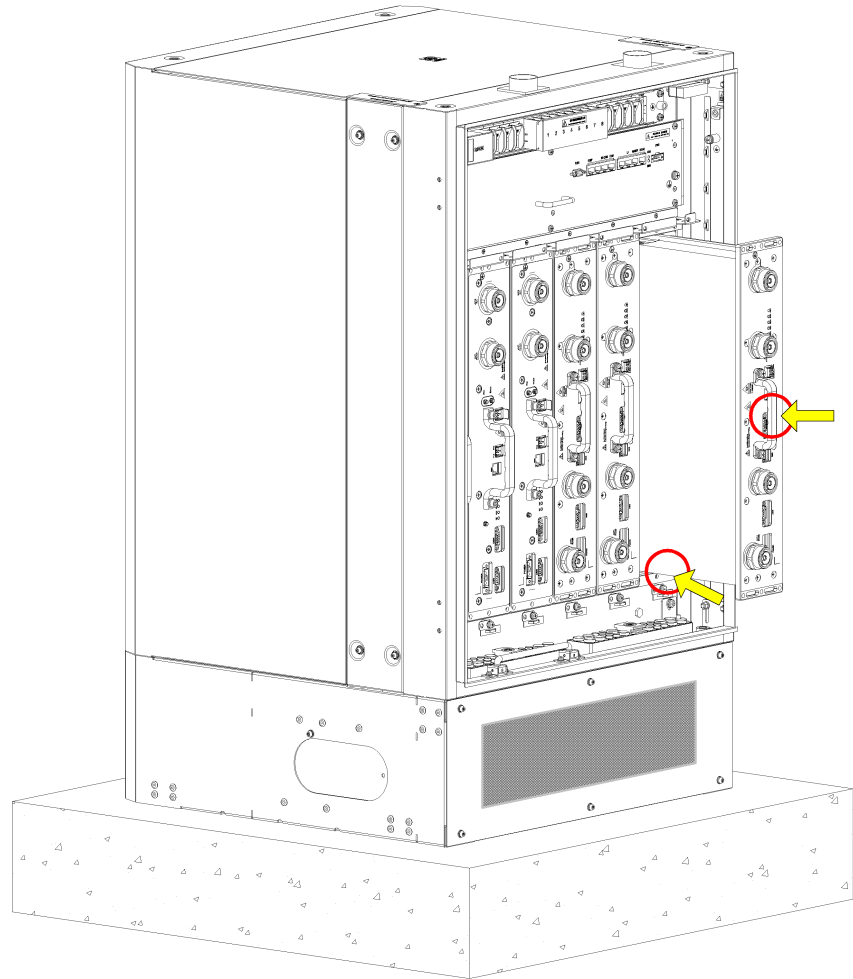

3. Change the place where exercise force and then push further the module with even force, as shown in [Figure 8](#).

FIGURE 8 STEP 3

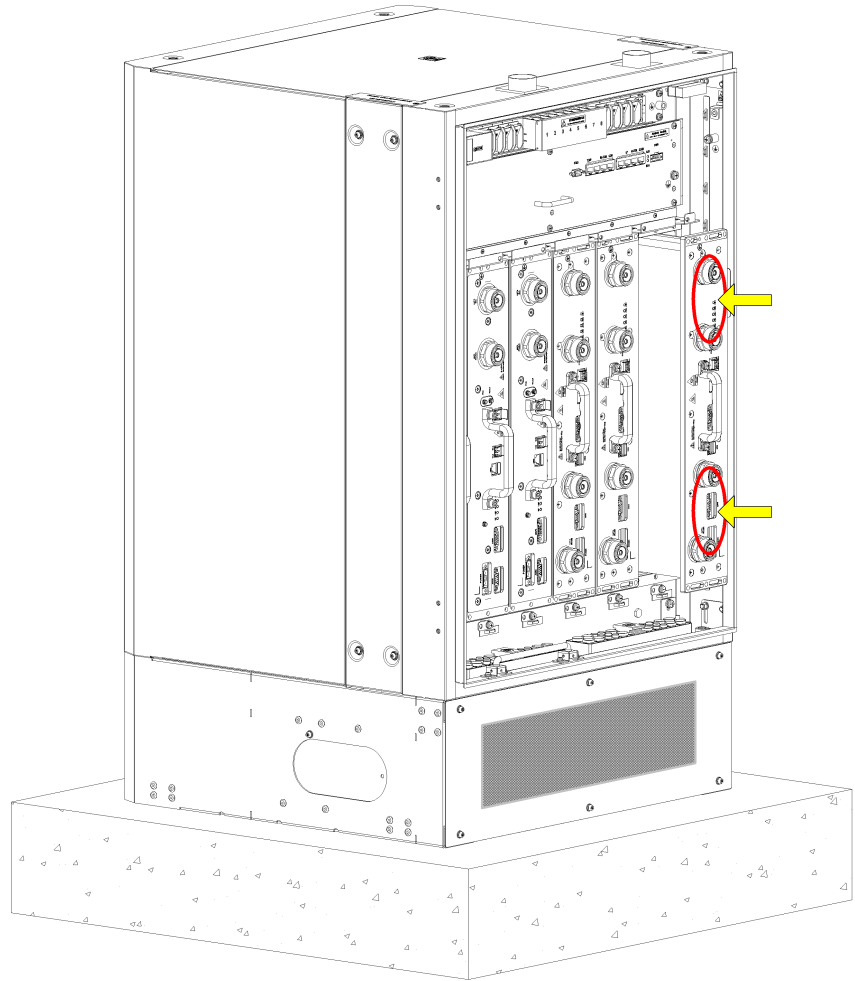

4. Push the module until the inner side of the front panel closely touch the vertical shaft, as shown in [Figure 9](#).

FIGURE 9 STEP 4

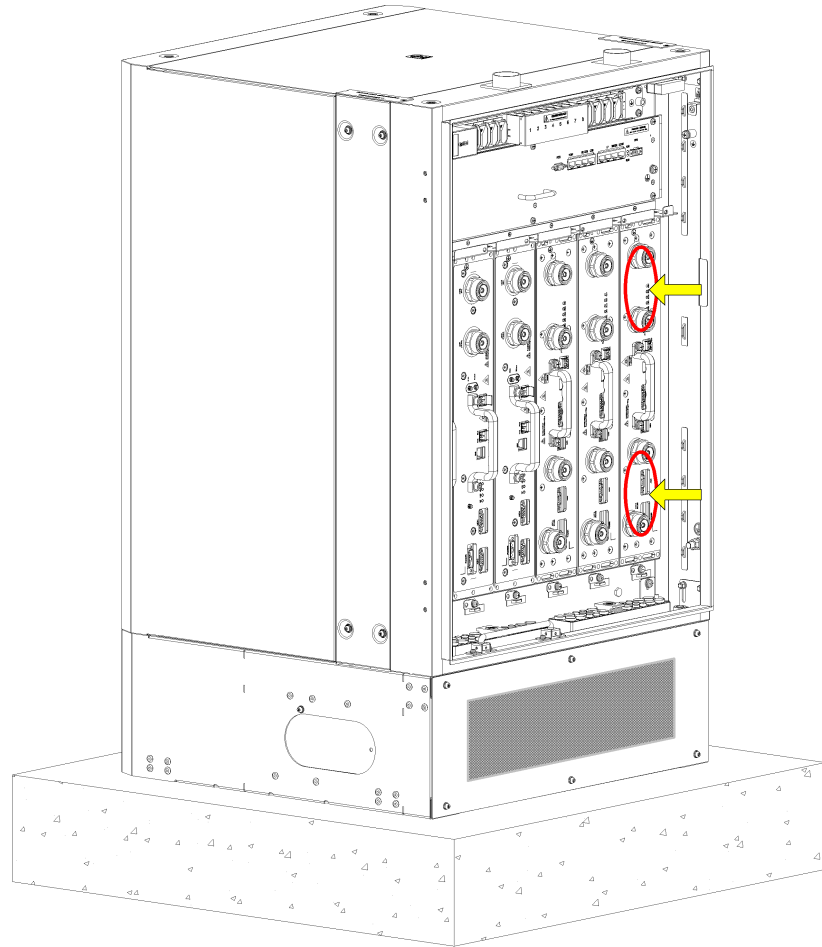

5. Secure the module using five M5 x 20 screws, as shown in [Figure 10](#).

FIGURE 10 STEP 5

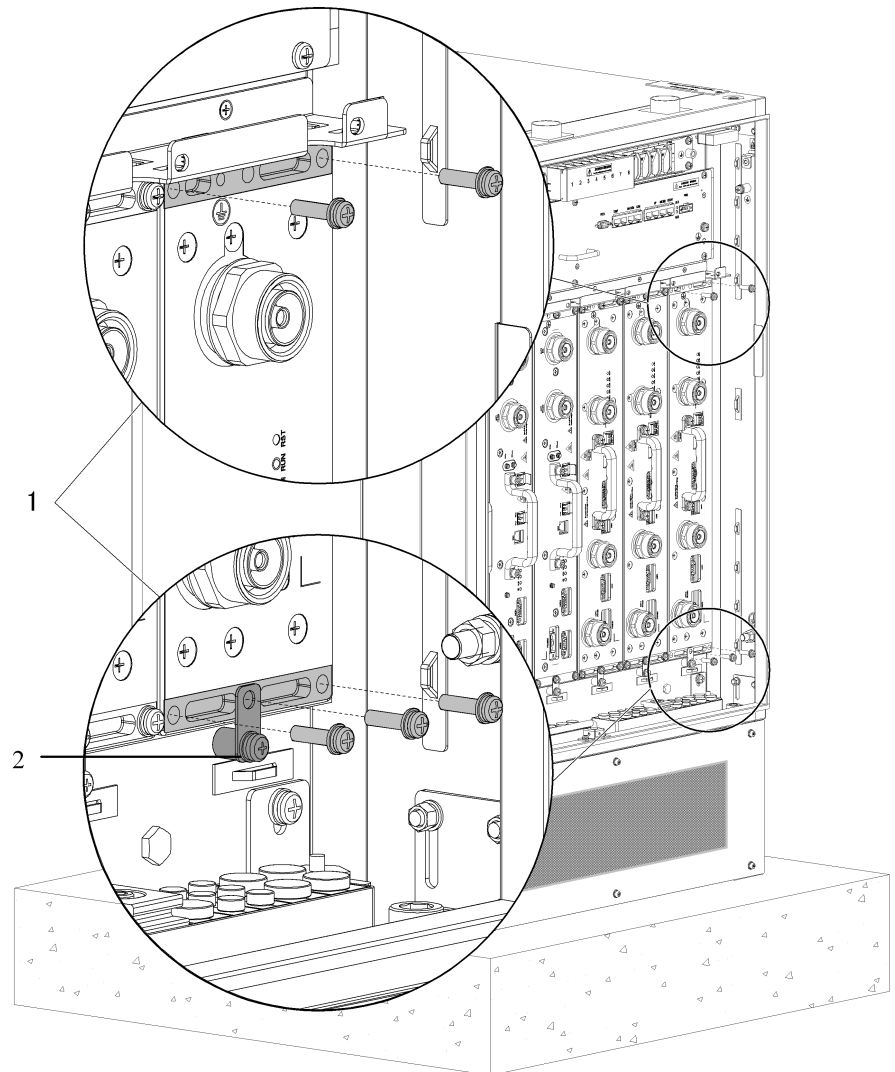

1. Fixing the cabinet with 5 M5x20 screws

2. Fixing the grounding lug

6. Secure the ground lug.

As shown in [Figure 10](#), the M5 x 20 screws secures the ground lug of the RSU module to the ground points.

**END OF STEPS**

---

**Result** [Figure 11](#) shows the completion of installing the RF module.

**FIGURE 11 RSU MODULE INSTALLED COMPLETELY**

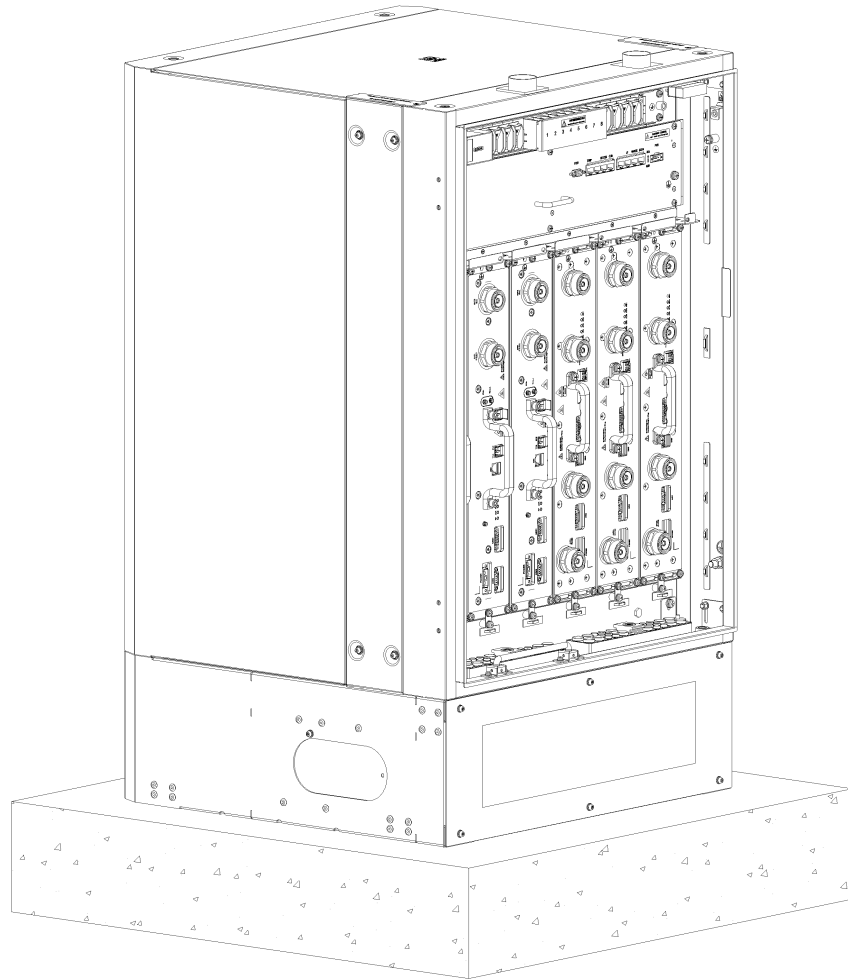

**Postrequisite** After installing RSU modules, connect the RSU power cables to the RSU power interfaces. RSU power cables have been routed to proper slots, as shown in [Figure 12](#).

**FIGURE 12 POWER CABLE CONNECTING THE RSU**





# Connecting RSU Monitoring Cable

- Prerequisites**
- ZXSDR RSUC RF cabinet has already been installed.
  - The RSU module has already been installed.

**Context** The RSU monitoring cable of the RF cabinet is routed to the right side of the RF cabinet in delivery, as shown in [Figure 13](#). After the RSU module is installed, insert the terminal of the RSU monitoring cable to the MON (monitoring) interface of the RSU module.

**FIGURE 13 RSU MONITORING CABLE**



**Note:**

If multiple RSU modules need to be monitored, only one RSU module needs to be connected to the RSU monitoring cable.

- Steps**
1. Connect one end of the RSU monitoring cable to the MON (monitoring) interface of the RSU module and fasten the screw.
  2. Bundle the RSU monitoring cable.

[Figure 14](#) shows the connected RSU monitoring cable.

FIGURE 14 INSTALLING THE RSU MONITORING CABLE

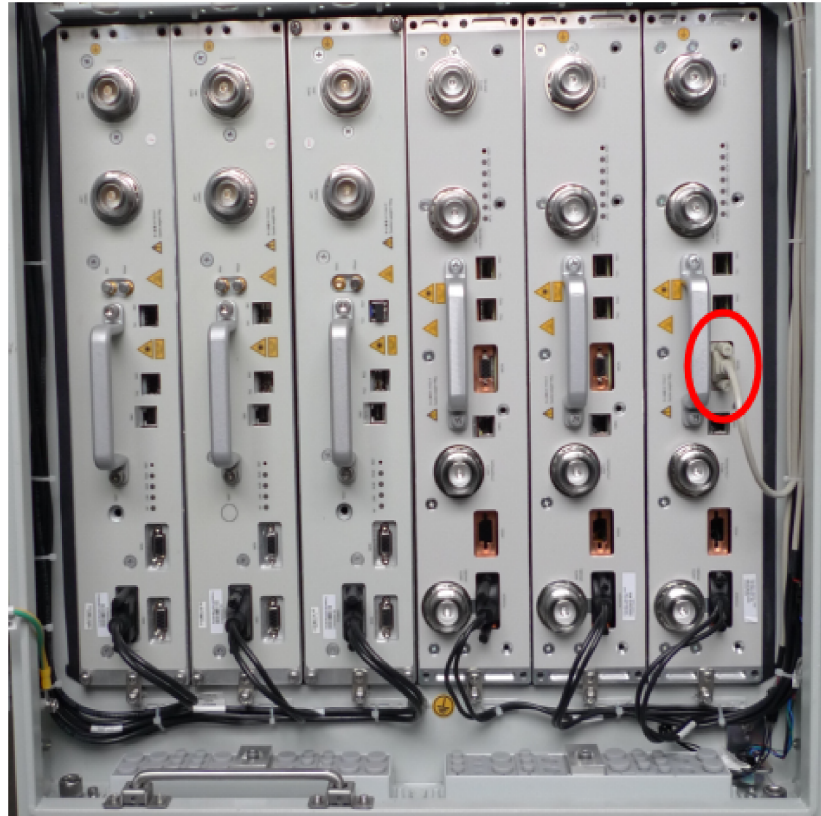
**END OF STEPS**

## Installing Optical Fibers Between BBU and RSU

- Prerequisites**
- The ESD wrist strap must be worn.
  - The baseband power cabinet and the RF cabinet have been independently installed.

**Context** When the baseband power cabinet and the RF cabinet are installed side by side or they are far away from each other, you need to connect BBU and RSU using optical fibers.

Pay attention to the following points when installing optical fibers:

- Do not damage the optical fiber cladding during operations.
- Protect optical fiber connectors and avoid contaminating them.
- Do not forcibly bundle optical fibers.
- Curve optical fibers at the turning.

- Steps**
1. Affix a temporary label.

Affix temporary labels to both ends of the new optical fiber to set up a mapping. If more than one optical fiber needs to be installed, use different labels to differentiate optical fibers.

2. Route optical fibers.
  - i. Optical fibers go out from the side waterproof module of the baseband module and go through the routing apertures on the base.
  - ii. Then, optical fibers go through the routing apertures on the base of the RF cabinet, traverse the waterproof modules, and connect to the six optical interfaces for RF modules.

[Figure 15](#) shows how optical fibers traverse the waterproof modules.

**FIGURE 15 WATERPROOF MODULE THROUGH WHICH OPTICAL FIBERS PASS**



3. Insert optical fiber connectors.

Insert optical fiber connectors according to the mapping on temporary labels.



**Caution:**

Insert optical fiber connectors tightly.

4. Bundle optical fibers.

Bundle and secure optical fibers along the routing troughs, which complies with relevant regulations.
5. Affix an engineering label to an optical fiber.

Remove the temporary label for the optical fiber and affix an engineering label.

**Caution:**

Protect an optical fiber with the winding tube when routing the optical fiber inside the cabinet. Protect an optical fiber with the corrugated pipe when routing the optical fiber outside the cabinet.

**END OF STEPS**

## Installing the Interconnected Cable Between BBU and RSU

- Prerequisites**
- The ZXSDR RSUC cabinet has already been installed.
  - The BBU module and RSU module have already been installed.

**Context** ZXSDR RSUC In the system, optical fibers or SFP cables can be used to connect BBU and RSU. During the stacked installation of the ZXSDR RSUC, a 2 m SFP high-speed cable is recommended for interconnecting BBU and RSU. [Figure 16](#) shows an SFP cable.

**FIGURE 16 HIGH-SPEED CABLE**



- Steps**
1. Affix temporary labels to both ends of the SFR cable, with markings 0-5 to set up one-to-one mapping with interfaces TX0RX0 to TX5RX5 of BBU and six TX/RX interfaces of RSU.
  2. Insert one end of the SFP cable to a TX/RX interface of RSU.

3. Route the SFP cable along the routing trough and cabinet sides to the FS module of BBU. The SFP cables connecting to the RSUs in slots 1 to 3 on the RF cabinet go through the left routing apertures and those SFP cables go through the right apertures if connecting to slots 4 to 6 on the RF cabinet, as shown in [Figure 17](#) and [Figure 18](#).

**FIGURE 17 LAYOUT OF THE SFP CABLES IN THE RF CABINET**

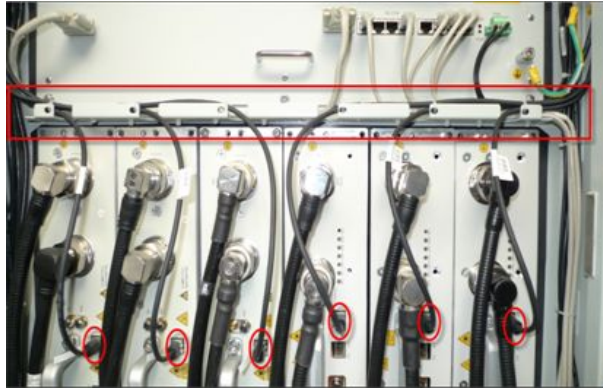

**FIGURE 18 SFP CABLE LAYOUT**

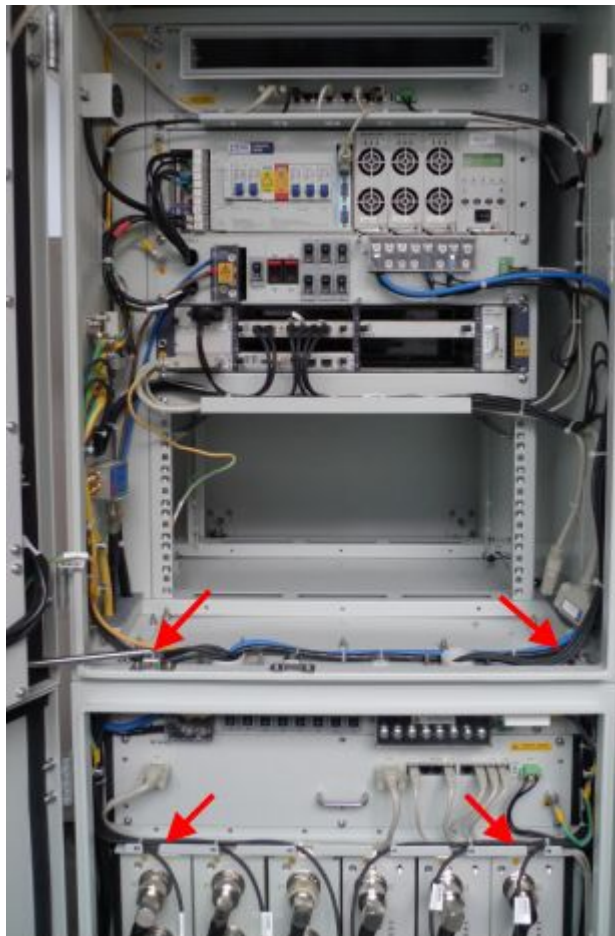

4. Insert SFP cables into the interfaces TX0RX0 to TX5RX5 of the BBU FS board according to the markings 0-5, as shown in [Figure 19](#).

**FIGURE 19 FS BOARD CONNECTING TO THE BBU**



5. Bundle SFP cables.
6. Remove temporary labels and affix engineering labels.

**END OF STEPS**

---

## Installing the RF Jumper

**Prerequisites** The ZXSDR RSUC RF cabinet and other modules have already been installed.

**Context** The RF jumpers for the three ZXSDR RSUC go through the waterproof module on the right.

Remove the front baffle of the base before installing the RF jumpers and reseal the front baffle after all jumpers are completely installed.

- Steps**
1. Connect the RF jumpers to ANT1 and ANT2 interfaces of RSU from left to right.
  2. Wear the waterproof rubber plug after every two RF jumpers are installed.
  3. Insert the horizontal and longitudinal slide blocks and use the hexagon ring wrench to fasten them.



**Caution:**

Clamp the waterproof rubber plug tightly and make sure that the unused cabling aperture wears the plug.

4. Repeat the preceding steps to install other RSU-related jumpers.

**END OF STEPS**

---

**Result** [Figure 20](#) shows the completion of installing the RF jumpers.

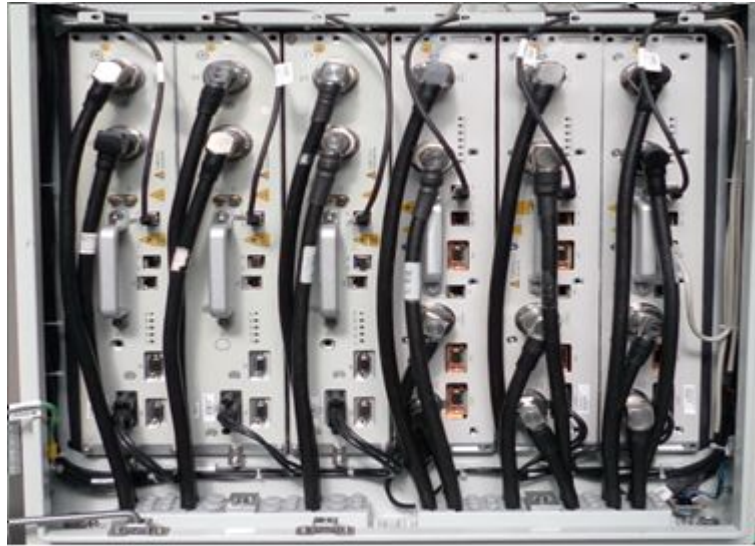
**FIGURE 20 ANTENNA FEEDER JUMPER INSTALLED COMPLETELY**

The RF jumpers go out from the base, as shown in [Figure 21](#). The cables between cabinets must be protected with protective tubes, without any exposed part of the cables and the openings at two ends of these cables must be sealed, as shown in [Figure 22](#).

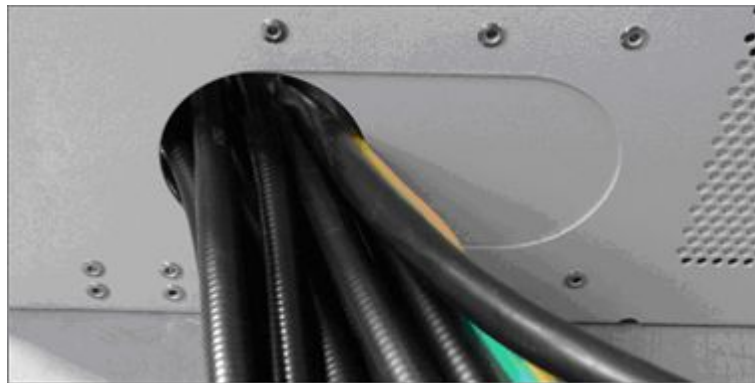
**FIGURE 21 LEAD-OUT OF THE ANTENNA FEEDER JUMPER**

**FIGURE 22 CABLES IN TUBES**

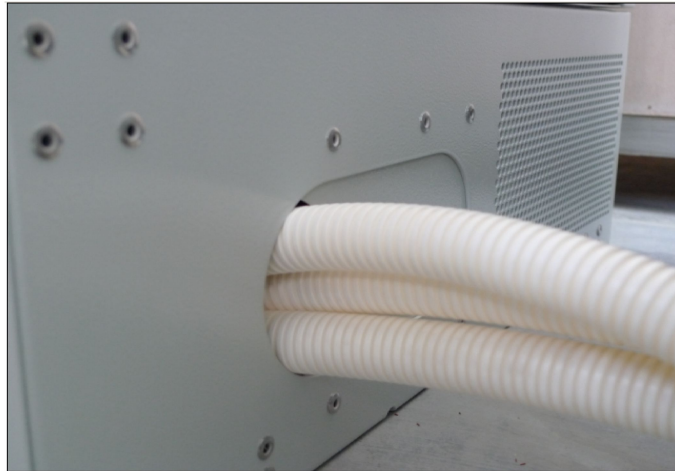



# Figures

---

Figure 1 ZXSDR RSUC Position in a Network.....	10
Figure 2 Outer View of ZXSDR RSUC .....	11
Figure 3 Schematic Diagram of the ZXSDR RSUC .....	13
Figure 4 ZXSDR RSUC Panel.....	24
Figure 5 ZXSDR RSUC Panel.....	28
Figure 6 Step 1 .....	29
Figure 7 Step 2 .....	30
Figure 8 Step 3 .....	31
Figure 9 Step 4 .....	32
Figure 10 Step 5 .....	33
Figure 11 RSU Module Installed Completely.....	34
Figure 12 Power Cable Connecting the RSU .....	34
Figure 13 RSU Monitoring Cable .....	35
Figure 14 Installing the RSU Monitoring Cable .....	36
Figure 15 Waterproof Module through Which Optical Fibers Pass.....	37
Figure 16 High-Speed Cable.....	38
Figure 17 Layout of the SFP Cables in the RF Cabinet .....	39
Figure 18 SFP Cable Layout.....	39
Figure 19 FS Board Connecting to the BBU.....	40
Figure 20 Antenna Feeder Jumper Installed Completely .....	41
Figure 21 Lead-Out of the Antenna Feeder Jumper .....	41
Figure 22 Cables in Tubes .....	42

This page is intentionally blank.

# Tables

---

Table 1 Safety Symbols Description.....	2
Table 2 The Primary Functions of ZXSDR RSUC.....	12
Table 3 The functions of subsystem.....	14
Table 4 ZXSDR RSUC Capacity Indices.....	15
Table 5 800 MHz Transmitter Indices .....	16
Table 6 1.9 GHz Transmitter Indices .....	17
Table 7 800 MHz Receiver Indices .....	19
Table 8 1.9 GHz Receiver Indices .....	20
Table 9 Description of ZXSDR RSUC's interfaces.....	21
Table 10 ZXSDR RSUC Panel Button Description.....	25
Table 11 ZXSDR RSUC Panel Indicator Description .....	25
Table 12 Interfaces on the Front Panel of the ZXSDR RSUC .....	26

This page is intentionally blank.

# Glossary

---

**BBU**

- BaseBand Unit

**BS**

- Base Station

**BSC**

- Base Station Controller

**BTS**

- Base Transceiver Station

**CDMA**

- Code Division Multiple Access

**CPRI**

- Common Public Radio Interface

**MS**

- Mobile Station

**RF**

- Radio Frequency

**RSSI**

- Received Signal Strength Indicator

**RSU**

- RF System Unit

**SDR**

- Software Defined Radio