

ZTE Z932L
Quick Start Guide

LEGAL INFORMATION

Copyright © 2013 ZTE CORPORATION.

All rights reserved.

No part of this publication may be quoted, reproduced, translated or used in any form or by any means, electronic or mechanical, including photocopying and microfilm, without the prior written permission of ZTE Corporation.

Notice

ZTE Corporation reserves the right to make modifications on print errors or update specifications in this guide without prior notice.

We offer self-service for our smart terminal device users. Please visit the ZTE official website (at www.zte.com.cn) for more information on self-service and supported product models. Information on the website takes precedence.

Disclaimer

ZTE Corporation expressly disclaims any liability for faults and damages caused by unauthorized modifications of the software.

Images and screenshots used in this guide may differ from the actual product. Content in this guide may differ from the actual product or software.

Trademarks

ZTE and the ZTE logos are trademarks of the ZTE Corporation.

Google and Android are trademarks of Google, Inc.

The *Bluetooth*[®] trademark and logos are owned by the Bluetooth SIG, Inc. and any use of such trademarks by ZTE Corporation is under license.

The microSD logo  is a trademark of the SD Card Association.

Other trademarks and trade names are the property of their respective owners.

Version No. : R1.0

Edition Time : 20130604

Manual No. :

Getting to Know Your Phone

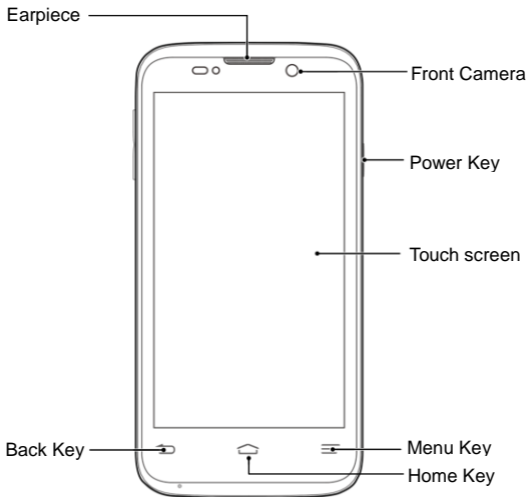

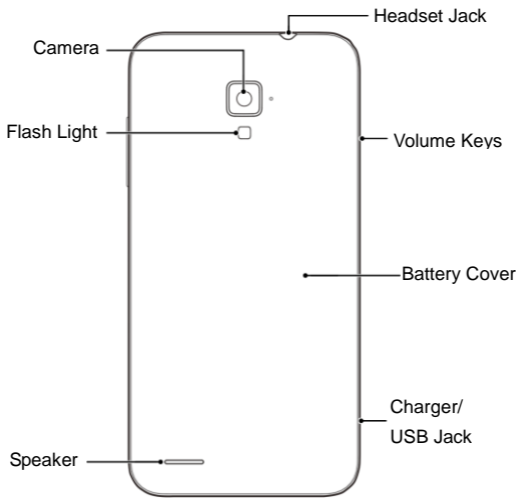

Knowing the Keys

Power Key

- Press and hold to power on, select phone modes, turn on/off airplane mode, or power off.
- Press to turn off or on the screen display.

Home Key

- Touch to return to the home screen from any application or screen.
- Touch and hold to see recently used applications.

Menu Key

Touch to get the options for the current screen.

Back Key

Touch to go to the previous screen.

Volume Keys

Press or hold to turn the volume up or down.

Starting Up

Switch off your phone before installing or replacing the battery. The microSD card is optional and can be installed and removed while the phone is turned on. Unmount the microSD card before removing it.

1. Place your finger in the slot at the bottom of the back cover to lift and remove the cover.

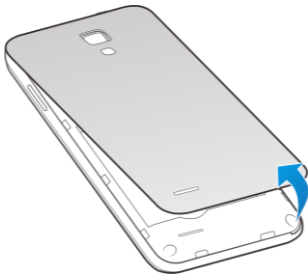

2. Switch off your phone before installing SIM card. Hold the SIM card with the cut corner oriented as shown and slip it into the card holder.

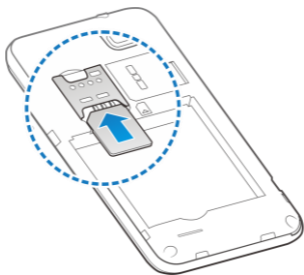

3. Insert the battery by aligning the contacts on the battery with the gold contacts in the battery compartment. Gently push down on the battery until it clicks into place.

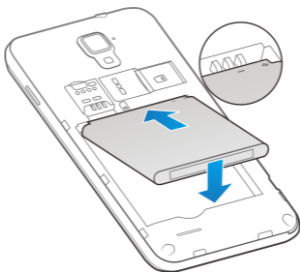

WARNING! Do not handle a damaged or leaking Li-Ion

battery as you can be burned.

4. Hold your microSD card with the metal contacts facing down and slide it into the microSD card slot.

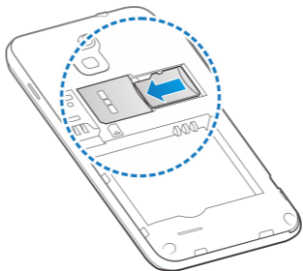

NOTE:

- Your phone may come with a pre-installed microSD card. Some applications may not function normally after you remove the card, pre-installed or otherwise.
 - Your phone has a 4GB capacity SD card is offered in the box. This should give you enough storage for normal use, but you can put in a larger SD card if you need more.
5. Press the cover gently back into place until you hear a click.

Charging the Battery

1. Connect the adapter to the charging jack. Ensure that the adapter is inserted with the correct orientation. Do not force the connector into the charging jack.

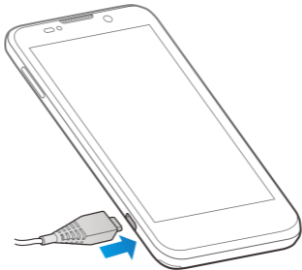

2. Connect the charger to a standard AC power outlet.
3. Disconnect the charger when the battery is fully charged.

Powering On/Off Your Phone

Make sure the battery is charged before powering on.

- Press and hold the **Power Key** to turn on your phone.
- To turn it off, press and hold the **Power Key** to open the options menu. Touch **Power off** > **OK**.

Getting to Know the Home Screen

The home screen is the starting point for your phone's applications, functions, and menus. You can customize your home screen by adding application shortcuts, folders, widgets, and more.

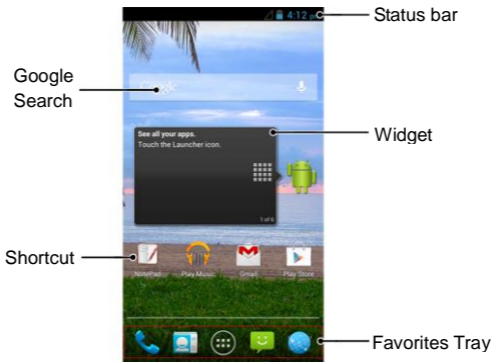

NOTE: Your home screen extends beyond the initial screen, providing more space for shortcuts, widgets, and folders. Simply swipe left or right to see the extended home screens.

Opening Applications

1. Touch the **Home Key** if the current screen is not the home screen.
2. Touch .
3. Slide left or right on the screen and touch an app to open it.

Adding Shortcuts or Widgets

1. Touch the **Home Key** > .
2. If you want to add a widget, touch **Widgets**.
3. Touch and hold a widget or an app icon and drag it to the home screen.

Removing Shortcuts or Widgets

1. Touch and hold a widget or shortcut on the home screen.
2. Drag it to  **Remove** to remove it.

Organizing Shortcuts With Folders

1. Touch and hold a shortcut on the home screen.
2. Drag it to  **folder** at the top of the screen. A new folder is created.
3. If needed, drag more shortcuts and drop them into the folder.











Applying New Wallpapers











You can set the wallpaper for the home screen or lock screen.

1. Touch the **Home Key > Menu Key > Wallpaper**.
2. Touch **Home** or **Lock screen**.
3. Select a wallpaper source from **Gallery**, **Live Wallpapers**, or **Wallpapers** and touch the image or animation you want to use as the wallpaper.
4. Touch **Done**, **Set wallpaper** or **SET WALLPAPER**.

Checking the Phone Status

The status bar at the top of the screen displays phone and service status with various icons on the right side. Below are some of the icons and their meanings.







	No signal		Signal strength
	3G connected		CDMA connected
	Roaming		Mobile data in use
	Bluetooth on		Wired headset connected
	Ringer off		Connected to a Wi-Fi network













	Vibrate mode		Wi-Fi in use
	Battery low		Speaker on
	Battery partially drained		Phone microphone off
	Battery full		Alarm set
	Battery charging		Flight mode

Managing Notifications

The status bar at the top of the screen provides notification alerts with different icons on the left side. Below are some of the icons and their meanings.

The notifications depend on the apps installed and you can touch and drag the status bar down to see more information.

	New SMS		microSD card unmounted
	New MMS		microSD card removed
	New Email		Upcoming event
	New Gmail message		Call on hold

	Updates available		New Wi-Fi network detected
	Problem with SMS/MMS delivery		Downloading/Saving/Download data
	Missed call		Sending data
	Call in progress		USB tethering is on
	USB connected		Wi-Fi direct is on
 	Song is playing		GPS on

Setting Ringtone and Sounds

Setting Ringtone or Notification Sound

1. Touch the **Home Key** >  > **Settings** > **Sound**.
2. Touch **Phone ringtone** or **Default notification**.
3. Select the ringtone you want to use.
4. Touch **OK**.



Setting System Sounds

1. Touch the **Home Key** >  > **Settings** > **Sound**.
2. Scroll to the **SYSEM** section and check the sounds you want to hear or uncheck those you do not need.

Adjusting Volumes

To adjust call volume, press the **Volume Key** while on a call. To adjust other volumes, follow the steps below.

1. Touch the **Home Key** >  > **Settings** > **Sound** > **Volumes**.
2. Drag the sliders to adjust the volume for music, video, games, and other media, the ringtone and notification volume, and the alarm volume.
3. Touch **OK** to save.

TIP: Press and hold the **Power Key** and then touch  to enable the silent mode, touch  to enable the vibration mode, or touch  to disable the silent mode.



Setting a Screen Lock

You can protect your phone by creating a screen lock. When enabled, you need to touch and hold an icon, draw a pattern, or enter a numeric PIN or password to unlock the phone's screen





and keys.



1. Touch the **Home Key > Menu Key > System settings > Security > Screen lock**.
2. Touch **None, Long press, Face Unlock, Pattern, PIN or Password**.
 - ▶ Touch **Long press** to enable unlock with a 'touch and hold' gesture. You can unlock the screen by touching and holding  at the center of the display.
 - ▶ Touch **Face Unlock** to create a pattern that you must look at your phone to unlock it.
 - ▶ Touch **Pattern** to create a pattern that you must draw to unlock the screen.
 - ▶ Touch **PIN or Password** to set a numeric PIN or a password you must enter to unlock your screen.

Checking Voicemail

1. Touch the **Home Key >** .
2. In the phone tab , touch and hold "1". If prompted, enter your voicemail password.
3. Follow the voice prompts to listen to and manage your voicemail messages.



Making a Call

1. Touch the **Home Key** > .
2. In the phone tab , enter the phone number with the on-screen keypad. Touch  to delete incorrect digits.
3. Touch the  icon below the keypad to place the call.

NOTE: To call a contact, touch the **Home Key** >  >  and touch a contact and number.



Adding Contacts

Creating a New Contact

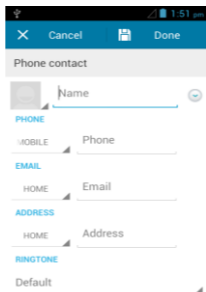

1. Touch the **Home Key** >  and touch the all contacts tab .
2. Touch  to add a new contact.
3. Enter the contact name, phone numbers, email addresses, and other information, as shown. Touch **Done** to save the contact.



Importing Contacts in Batches

1. Touch the **Home Key** >  and touch the all contacts tab .
2. Touch the **Menu key** > **Import/export** > **Import from phone storage** or **Import from SD card**.
3. If prompted, select an account in which to save the contacts.
4. For importing from the microSD card, select the vCard file(s) on the microSD card and touch **OK** to begin importing.

Sending a Message

1. Touch  in the home screen and select **Messaging**, then touch .
2. Enter the recipient(s) and message text. If you want to send an MMS, add subject and attachments.
3. Touch **Send** to send the message.

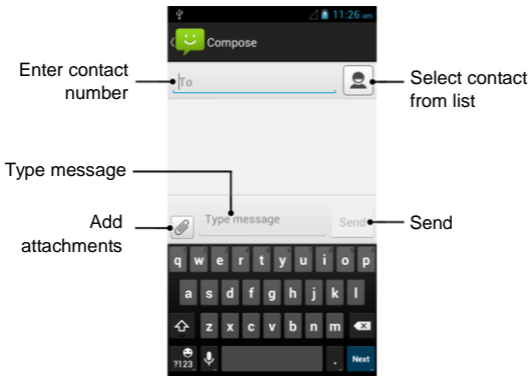

Setting Up Email Accounts

Setting Up Gmail

1. Touch  in the home screen and select **Gmail**.
NOTE: If another Gmail account is already set up, touch the **Menu Key > Settings > Add Account**.
2. Touch Existing to sign in to your existing Google Account. If you have no Google Accounts, touch New to create one.
3. Follow the instructions on the screen to set up the account.

Setting Up Email

1. Touch  in the home screen and select **Email**.
NOTE: If another email account is already set up, touch the **Menu Key > Settings > Add Account**.
2. Enter the email address and password.
3. Touch **Next** and follow the onscreen instructions.

Setting Up Corporate Exchange Email

1. Touch  in the home screen and select **Email**.
NOTE: If another email account is already set up, touch the **Menu Key > Settings > Add Account**.
2. Enter the email address and password.

3. Touch **Manual setup > Exchange**.
4. Enter **Domain\Username**, **Password**, and **Server** information.
5. Read the onscreen activation disclaimer and, if prompted, touch **Next**.
6. If prompted, touch **OK** to allow the server to remotely control some of your phone's security features.
7. Configure the settings on the screen, such as **Days to sync**, and then touch **Next**.
8. If prompted, touch **Activate** to activate the Email app as a device administrator.
9. Identify your new account with a unique name and then touch **Next**.

Contact your server administrator for more help.

Connecting With a Bluetooth Headset

1. Turn on the Bluetooth headset and switch it to pairing mode. Refer to the headset's user guide for more information.
2. Touch  in the home screen and select **Settings > Bluetooth**.
3. Slide the **ON/OFF** switch if Bluetooth is off. When Bluetooth

is on, the  icon appears in the status bar.

NOTE: Your phone automatically scans for and displays the IDs of all available Bluetooth devices in range. You can touch **SEARCH FOR DEVICES** if you want to scan again.

4. Touch the ID of the headset, or any other device you want to pair with your phone. Enter a password if prompted.
5. If necessary, touch the ID of the paired headset to connect with it. Once connected, the  icon in the status bar turns blue.

TIP: Touch the ID again to end the connection.

Installing Apps From the Google Play Store



There are tens of thousands of games and applications in the Google Play Store for you to download and install. You can send feedback or comments on an application.

Before you begin, make sure that you have signed in to your Google account.

NOTE: The content you can access in the Play Store depends on your region and your service provider.

1. Touch the **Home Key** >  > **Play Store**.
The first time you launch **Play Store**, accept the Google Play Terms of Service.

2. Find the apps you need either by category or by touching .
3. Touch the app to see detailed description.
4. Touch **Install** (free apps) or the price (paid apps). If the app is not free, you need to sign in to your Google Wallet account and select a payment method.
CAUTION: Once installed, some apps can access many functions or a significant amount of your personal data. The Play Store will show you what the app can access. Touch **ACCEPT** (free apps) or **Accept & buy** (paid apps) to proceed, or touch the **Back Key** to cancel.
5. Wait for the app to be downloaded and installed automatically. Payment needs to be authorized before paid apps start downloading.

The app is successfully installed when the  icon appears in the status bar. You can find the new app after touching the **Home Key** > .

Taking a Photo

1. Touch  in the home screen and select **Camera**.
2. Aim the camera at the subject and make any necessary adjustment.

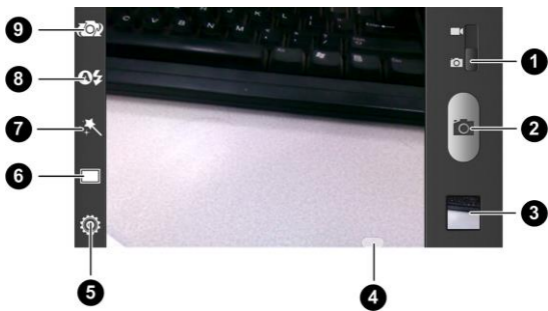

Number	Function
1	Switch to the camcorder.
2	Capture a photo.
3	View photos and videos you have captured.
4	Hold the slider and slide to zoom in or out.
5	Change the camera settings.
6	Switch between normal and timing mode.
7	Select the color effect.
8	Turn on/off flash.
9	Switch between the front and the back cameras.

3. Lightly touch the capture button .



Recording a Video

1. Touch  in the home screen and select **Camera**.
2. Switch to the camcorder mode.
3. Aim the camera at the subject and make any necessary adjustment.



Number	Function
1	Switch to the camera.
2	Start or stop recording a video.
3	View photos and videos you have captured.
4	Hold the slider and slide to zoom in or out.

Number	Function
5	Change the camcorder settings.
6	Turn on/off flash.
7	Switch between the front and the back cameras.

4. Touch  to start and  to stop recording.

TIP: While the recording is in progress, you can touch the  button to save the frame as a photo.

Playing Music

1. Touch  in the home screen and select **Play Music**.
2. Touch a category, such as Artists or Albums, to find the song you want to play.
3. Touch the song to play it back. When the song is playing, touch the album artwork to display more options.

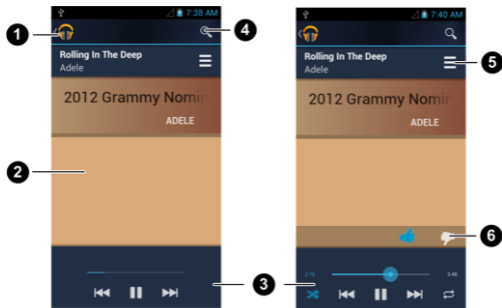

Number	Function
1	Touch to view the current playing list.
2	Album artwork.
3	Playback control. Skip songs, pause and resume playback, use shuffle or repeat. Drag the progress bar to jump to any part of the song.
4	Search for music.
5	Back to Now playing list.
6	Rate the song.

Connecting to PC

You can connect your phone to a computer with a USB cable and transfer music, pictures, and other files in both directions. Your device stores these files in internal storage or on a removable microSD card.

1. Touch and hold the status bar across the top of the screen and flick down.



2. Touch  (**Connected as [current connection mode]**).
3. Choose one of the following options:
 - ▶ **Charge only:** Charge your phone via USB.
 - ▶ **Install driver:** Install the driver needed for connecting your phone to your PC.

- ▶ **Media device (MTP):** Transfer media files on Windows, or using Android File Transfer on Mac.
- ▶ **Camera (PTP):** Transfer photos using camera software, and transfer any files on computers that don't support MTP.

To disconnect the device from the computer, simply unplug the USB cable when you're finished.

Connecting to the Internet

Connecting via Wi-Fi

1. Touch the **Home Key > Menu Key > System settings > Wi-Fi**.

2. Slide the ON/OFF switch if Wi-Fi is off.

Your phone automatically searches for Wi-Fi networks in range and displays their names and security settings. Your phone also connects to previously linked networks when they are in range.

3. Touch a network name to connect to it.

If the network is secured, enter a password or other credentials. (Ask your network administrator for details.)

Connecting via Mobile Network

1. Touch the **Home Key >  > Settings > Mobile**

networks.

2. Check **Data enabled.**



Extending Battery Life

There are several things you can do to make your battery last longer.

- Turn on Wi-Fi, Bluetooth, GPS, mobile data, auto-sync only when you need to.
- Lower the screen brightness.
- From the home screen, touch  > **Task Manager** and close the apps you do not need but still run in the background.

Freeing Up Memory Space

Use **Task Manager** to free up memory space and optimize system speed.

1. From the home screen, touch  > **Task Manager**.
2. Touch the **Tasks** tab and touch the  button next to the application you do not need.
You can also touch **CLOSE ALL** to stop all running applications.

Managing the Phone Storage

Deleting Old Messages



















You can manually delete old messages to free up some storage space. You may also set up auto deletion of the oldest messages when the limits are reached.

1. From the home screen, touch  > **Messaging**.
2. Touch the **Menu Key > Settings**.
3. Check **Delete old messages** to enable auto deletion.
4. Touch **Text message limit** or **Multimedia message limit** to set the maximum limit.
5. Touch **Set**.

Clearing Browser's Local Content

1. From the home screen, touch  > **Browser**.
2. Touch the **Menu Key > Settings > Privacy & security**.
3. Touch **Clear cache**, **Clear history**, and **Clear all cookie data**.

Product Safety Information

	Do not use hand-held while driving		Do not use while re-fuelling
	For body-worn operation maintain a separation of 15 mm		This device may produce a bright or flashing light
	Small parts may cause a choking hazard		Do not dispose of it in a fire
	This device may produce a loud sound		To prevent possible hearing damage, do not listen at high volume levels for long periods.
	Avoid contact with magnetic media		Avoid Extreme Temperatures
	Keep away from pacemakers and other personal medical devices		Avoid any contact with liquid, keep it dry
	Switch off when instructed in hospitals and medical facilities		Do not attempt to disassemble
	Switch off when instructed in aircrafts and airports		Only use approved accessories
	Switch off in explosive environments		Do not rely on this device for emergency communications

Radio Frequency (RF) Energy

This model phone meets the government's requirements for exposure to radio waves.

This phone is designed and manufactured not to exceed the emission limits for exposure to radio frequency (RF) energy set by the Federal Communications Commission of the U.S. Government:

The exposure standard for wireless mobile phones employs a unit of measurement known as the Specific Absorption Rate, or SAR.

The SAR limit set by the FCC is 1.6 W/kg.

Tests for SAR are conducted using standard operating positions accepted by the FCC with the phone transmitting at its highest certified power level in all tested frequency bands. Although the SAR is determined at the highest certified power level, the actual SAR level of the phone while operating can be well below the maximum value. This is because the phone is designed to operate at multiple power levels so as to use only the power required to reach the network. In general, the closer you are to a wireless base station, the lower the power output.

The highest SAR values for this model phone as reported to the FCC when tested for use at the ear and on the body are:

Head: 1.37 W/kg, Body: 1.31 W/kg.

(Body-worn measurements differ among phone models, depending upon available enhancements and FCC requirements.)

While there may be differences between the SAR levels of individual Z932L phones and at various positions, they all meet the government requirement.

The FCC has granted an Equipment Authorization for this model phone with all reported SAR levels evaluated as in compliance with the FCC RF exposure guidelines. SAR information on this model phone is on file with the FCC and can be found under the Display Grant section of <http://www.fcc.gov/oet/ea/fccid> after searching on

FCC ID: Q78-Z932L

For body worn operation, this phone has been tested and meets the FCC RF exposure guidelines for use with an accessory that contains no metal and that positions the handset a minimum of 1.0 cm from the body. Use of other enhancements may not ensure compliance with FCC RF exposure guidelines. If you do not use a body-worn accessory and are not holding the phone at the ear, position the handset a minimum of 1.0 cm from your body when the phone is switched on.

FCC Compliance

This device complies with part 15 of the FCC Rules. Operation is subject to the following two conditions: (1) This device may not cause harmful interference, and (2) this device must accept any interference received, including interference that may cause undesired operation.

CAUTION: Changes or modifications not expressly approved by the manufacturer could void the user's authority to operate the equipment.

NOTE: This equipment has been tested and found to comply with the limits for a Class B digital device, pursuant to part 15 of the FCC Rules.

These limits are designed to provide reasonable protection against harmful interference in a residential installation. This equipment generates, uses and can radiate radio frequency energy and, if not installed and used in accordance with the instructions, may cause harmful interference to radio communications. However, there is no guarantee that interference will not occur in a particular installation. If this equipment does cause harmful interference to radio or television reception, which can be determined by turning the equipment off and on, the user is encouraged to try to correct the interference by one or more of the following measures:

- Reorient or relocate the receiving antenna.

- Increase the separation between the equipment and receiver.
- Connect the equipment into an outlet on a circuit different from that to which the receiver is connected.
- Consult the dealer or an experienced radio/TV technician for help.
-

Hearing Aid Compatibility (HAC)

In 2003, the FCC adopted rules to make digital wireless telephones compatible with hearing aids and cochlear implants. Although analog wireless phones do not usually cause interference with hearing aids or cochlear implants, digital wireless phones sometimes do because of electromagnetic energy emitted by the phone's antenna, backlight, or other components. Your phone is compliant with FCC HAC regulations (ANSI C63.19- 2011). While some wireless phones are used near some hearing devices (hearing aids and cochlear implants), users may detect a buzzing, humming, or whining noise. Some hearing devices are more immune than others to this interference noise and phones also vary in the amount of interference they generate. The wireless telephone industry has developed a rating system for wireless phones to assist hearing device users in finding phones that may be compatible with their hearing devices. Not all

phones have been rated. Phones that are rated have the rating on their box or a label located on the box. The ratings are not guarantees. Results will vary depending on the user's hearing device and hearing loss. If your hearing device happens to be vulnerable to interference, you may not be able to use a rated phone successfully. Trying out the phone with your hearing device is the best way to evaluate it for your personal needs.

This phone has been tested and rated for use with hearing aids for some of the wireless technologies that it uses. However, there may be some newer wireless technologies used in this phone that have not been tested yet for use with hearing aids. It is important to try the different features of this phone thoroughly and in different locations, using your hearing aid or cochlear implant, to determine if you hear any interfering noise. Consult your service provider or the manufacturer of this phone for information on hearing aid compatibility. If you have questions about return or exchange policies, consult your service provider or phone retailer.

M-Ratings: Phones rated M3 or M4 meet FCC requirements and are likely to generate less interference to hearing devices than phones that are not labeled. M4 is the better/higher of the two ratings.

T-Ratings: Phones rated T3 or T4 meet FCC requirements and are likely to be more usable with a hearing device's telecoil ("T Switch" or "Telephone Switch") than unrated phones. T4 is the better/ higher of the two ratings. (Note that not all hearing devices have telecoils in them.)

Your phone meets the M4/T4 level rating.

Hearing devices may also be rated. Your hearing device manufacturer or hearing health professional may help you find this rating. For more information about FCC Hearing Aid Compatibility, please go to <http://www.fcc.gov/cgb/dro>.

Distraction

Driving

Full attention must be given to driving at all times in order to reduce the risk of an accident. Using a phone while driving (even with a hands free kit) can cause distraction and lead to an accident. You must comply with local laws and regulations restricting the use of wireless devices while driving.

Operating Machinery

Full attention must be given to operating machinery in order to reduce the risk of an accident.

Product Handling

General Statement on Handling and Use

You alone are responsible for how you use your phone and any consequences of its use.

You must always turn off your phone wherever the use of a phone is prohibited. Use of your phone is subject to safety measures designed to protect users and their environment.

- Always treat your phone and its accessories with care

and keep it in a clean and dust-free place.

- Keep the screen and camera lens clean. Unclean screen or camera lens may slow down the phone's reaction to your operations or lower image quality.
- Clean the device and its accessories with a soft material such as cleaning cloth for eyeglass lenses. Do not use alcohol or other corrosive substances for cleaning or allow them to get inside.
- Do not expose your phone or its accessories to open flames or lit tobacco products.
- Do not expose your phone or its accessories to liquid, moisture or high humidity.
- Do not drop, throw or try to bend your phone or its accessories.
- Do not paint your phone or its accessories.
- Do not attempt to disassemble your phone or its accessories. Only authorized personnel can do so.
- Do not expose or use your phone or its accessories in an environment with or that can reach extreme temperatures, minimum - [5] and maximum + [50] degrees Celsius.
- Do not place your phone inside or near heating equipments or high pressure containers, such as water heaters, microwave ovens, or hot cooking utensils. Otherwise, your phone may be damaged.

- Please check local regulations for disposal of electronic products.
- Do not carry your phone in your back pocket as it could break when you sit down.

Small Children

Do not leave your phone and its accessories within the reach of small children or allow them to play with it.

They could hurt themselves or others, or could accidentally damage the phone.

Your phone contains small parts with sharp edges that may cause an injury or may become detached and create a choking hazard.

Demagnetization

To avoid the risk of demagnetization, do not allow electronic devices or magnetic media to be close to your phone for a long time.

Electrostatic Discharge (ESD)

Do not touch the metal connectors of the phone.

Antenna

Do not touch the antenna unnecessarily.

Normal Use Position

When placing or receiving a phone call, hold your phone to your ear, with the bottom towards your mouth.

Air Bags

Do not place a phone in the area over an air bag or in the air bag deployment area as an airbag inflates with great force and serious injury could result.

Store the phone safely before driving your vehicle.

Seizures/Blackouts

The phone can produce a bright or flashing light. A small percentage of people may be susceptible to blackouts or seizures (even if they have never had one before) when exposed to flashing lights or light patterns such as when playing games or watching video. If you have experienced seizures or blackouts or have a family history of such occurrences, please consult a physician.

Repetitive Strain Injuries

To minimize the risk of Repetitive Strain Injury (RSI) when texting or playing games with your phone:

- Do not grip the phone too tightly.
- Press the buttons lightly.

- Use the special features which are designed to minimize the times of pressing buttons, such as Message Templates and Predictive Text.
- Take many breaks to stretch and relax.

Emergency Calls

This phone, like any wireless phone, operates using radio signals, which cannot guarantee connection in all conditions. Therefore, you must never rely solely on any wireless phone for emergency communications.

Loud Noise

This phone is capable of producing loud noises, which may damage your hearing. Turn down the volume before using headphones, Bluetooth stereo headsets or other audio devices.

Phone Heating

Your phone may become warm during charging and during normal use.

Electrical Safety

Accessories

Use only approved accessories.

Do not connect with incompatible products or accessories.
Take care not to touch or allow metal objects, such as coins or key rings, to contact or short-circuit in the battery terminals.
Never puncture the surface of the battery with sharp objects.

Connection to a Car

Seek professional advice when connecting a phone interface to the vehicle electrical system.

Faulty and Damaged Products

Do not attempt to disassemble the phone or its accessories.
Only qualified personnel can service or repair the phone or its accessories.

If your phone (or its accessories) has been submerged in water, punctured, or subjected to a severe fall, do not use it until you have taken it to be checked at an authorized service center.

Radio Frequency Interference

General Statement on Interference

Care must be taken when using the phone in close proximity to personal medical devices, such as pacemakers and hearing aids.

Pacemakers

Pacemaker manufacturers recommend that a minimum separation of 15 cm be maintained between a mobile phone and a pacemaker to avoid potential interference with the pacemaker. To achieve this, use the phone on the opposite ear to your pacemaker and do not carry it in a breast pocket.

Hearing Aids

People with hearing aids or other cochlear implants may experience interfering noises when using wireless devices or when one is nearby.

The level of interference will depend on the type of hearing device and the distance from the interference source. Increasing the separation between them may reduce the interference. You may also consult your hearing aid manufacturer to discuss alternatives.

Medical Devices

Please consult your doctor and the device manufacturer to determine if operation of your phone may interfere with the operation of your medical device.

Hospitals

Turn off your wireless device when requested to do so in hospitals, clinics or health care facilities. These requests are

designed to prevent possible interference with sensitive medical equipment.

Aircraft

Turn off your wireless device whenever you are instructed to do so by airport or airline staff.

Consult the airline staff about the use of wireless devices onboard the aircraft. If your device offers a 'flight mode', this must be enabled prior to boarding an aircraft.

Interference in Cars

Please note that because of possible interference with electronic equipment, some vehicle manufacturers forbid the use of mobile phones in their vehicles unless a hands-free kit with an external antenna is included in the installation.

Explosive Environments

Gas Stations and Explosive Atmospheres

In locations with potentially explosive atmospheres, obey all posted signs to turn off wireless devices such as your phone or other radio equipment.

Areas with potentially explosive atmospheres include fueling areas, below decks on boats, fuel or chemical transfer or storage facilities, and areas where the air contains chemicals

or particles, such as grain, dust, or metal powders.

Blasting Caps and Areas

Power off your mobile phone or wireless device when in a blasting area or in areas posted power off “two-way radios” or “electronic devices” to avoid interfering with blasting operations.