

SPECIFICATION

ZM460B-APS

9PA4601100

**Main Feature: Low Noise High Efficiency Active PFC Circuit
Full Range Input**

DEC 21, 2005

REV:01

MODEL: ZM460B-APS

Revision History

Rev	Description	Date	Author
1.0		2005/12/26	

1. GENERAL DESCRIPTION AND SCOPE

This is the specification of Model ZM460B-APS; AC-line powered switching power supply with active PFC (Power Factor Correction) circuit, meet EN61000-3-2 and with Full Range Input features.

The specification below is intended to describe as detailedly as possible the functions and performance of the subject power supply. Any comment or additional requirements to this specification from our customers will be highly appreciated and treated as a new target for us to approach.

2. REFERENCE DOCUMENTS

The subject power supply will meet the EMI requirements and obtain main safety approvals as following:

2.1 EMI REGULATORY

- FCC Part 15 Subpart J, Class 'B' 115 Vac operation.
- CISPR 22 Class 'B' 230 Vac operation.

2.2 SAFETY

- NEMKO EN 60950
- TUV EN60950 OR VDE EN60950 -CSA-C22.2 NO. 60950 -IEC 60950
- UL 60950
- CE : EN 55022:1998+A1: 2000, Class B EN 61000-3-2: 2000 EN 61000-3-3: 1995+A1: 2001

CISPR22: 1997+A1: 2000, Class B

AS/NZS CISPR 22: 2002, Class B

3. INPUT ELECTRICAL SPECIFICATIONS

3.1. AC INPUT

Parameter	Min.	Nom.(1)	Max.	Unit
V _{in} (115VAC)	90	115	135	VAC _{rms}
V _{in} (230VAC)	180	230	265	VAC _{rms}
V _{in} Frequency	47		63	HZ

◆ Nominal voltages for test purposes are considered to be within $\pm 1.0V$ of nominal.

3.2. INRUSH CURRENT (Cold start – 25 deg. C)

115V	No damage
230V	No damage

Maximum inrush current from power-on (with power on at any point on the AC sine) and including, but not limited to, three line cycles, shall be limited to a level below the surge rating of the input line cord, AC switch if present, bridge rectifier, fuse, and EMI filter components. Repetitive ON/OFF cycling of the AC input voltage should not damage the power supply or cause the input fuse to blow.

3.3. INPUT LINE CURRENT

115V	5.5Amps – rms maximum
230V	3Amps – rms maximum

3.4. EFFICIENCY

3.4.1 General

Under the load conditions defined in Table 1 and Table 2. The loading condition for testing efficiency shown in Table 1 represents a fully loaded system. a ~ 50% (typical) loaded system. and a ~ 20% (light) loaded system.

Table. 1 Loading Table for Efficiency Measurements

460W(loading shown in Amps)						
Loading	+12V1	+12V2	+5V	+3.3V	-12V	+5Vsb
Full	14.0	15.0	11.0	13.0	0.4	2.0
Typical	6.0	10.0	4.0	6.0	0.1	1.0
Light	3.0	3.5	2.0	4.0	0.0	1.0

Table 2. Minimum Efficiency Vs Load

Loading	Voltage	Full load	Typical load	Light load
Required Minimum Efficiency	115V	75%	75%	70%
Required Minimum Efficiency	230V	80%	80%	75%

3.5 MECHANICAL SPECIFICATIONS

The mechanical drawing of the subject power supply, which indicate the form factor, location of the mounting holes, location, the length of the connectors, and other physical specifications of the subject power supply. Please refer to the attachment drawing.

4.0. OUTPUT ELECTRICAL REQUIREMENTS

4.1 OUTPUT VOLTAGE AND CURRENT RATING

Output	MINIMUM LOAD	NORMAL LOAD	MAXIMUM LOAD	LOAD REG	LINE REG.	RIPPLE&NOISE	RIPPLE
+3.3V	0.5A	15A	30A	±5%	±1%	100mV P-P	50mV P-P
+5V	0.3A	15A	30A	±5%	±1%	100mV P-P	50mV P-P
+12V1	1A	8A	16 A	±5%	±1%	200mV P-P	120mV P-P
+12V2	1A	9A	18A	±5%	±1%	200mV P-P	120mV P-P
-12V	0A	0.25A	0.5A	±10%	±1%	200mV P-P	120mV P-P
+5VSB	0A	1.25A	2.5A	±5%	±1%	100mV P-P	50mV P-P

- (1) +3.3V & +5V total output not exceed 152W.
- (2) +3.3V & +5V & +12V1 & +12V2 total output not exceed 440W
- (3) total output for this subject power supply is 460 watts
- (4) +5VSB Peak current loading is 3A , shall be supported for a minimum of 500m second. .

4.2. LOAD

CAPACITY SPECIFICATIONS

The cross regulation defined as follows, the voltage regulation limits DC include DC Output ripple & noise.

LOAD	STM.	+3.3V	+5V	+12V1 DC	+12V2 DC	-12V	+5VSB
FULL LOAD	LHHMHH	0.5A	30A	16A	8.1A	0.5A	2.5A
FULL LOAD	HMMHHH	30A	10.6A	6.1A	18A	0.5A	2.5A
+3.3V MAX other MIN	HLLLLL	30A	0.3A	1A	1A	0A	0A
+5V MAX Other MIN	LHLLLL	0.5A	21A	1A	1A	0A	0A
+12V1&+12V2 MAX Other MIN	LLHHLL	0.5 A	2.0A	16A	18A	0A	0A
-12V MAX other MIN	LLLLHL	0.5A	0.3A	1A	1A	0.5A	0A
+5VSB MAX other MIN	LLLLLH	0.5A	0.3A	1A	1A	0A	2.5A
ALL MIN	LLLLLL	0.5A	0.3 A	1A	1A	0A	0A

4.3. HOLD-UP TIME (@FULL LOAD)

115V / 60Hz : 17 mSec. Minimum. 230V / 50Hz : 17 mSec. Minimum.

The output voltage will remain within specification, in the event that the input power is removed or interrupted, for the duration of one cycle of the input frequency. The interruption may occur at any point in the AC voltage cycle. The power good signal shall remain high during this test.

4.4. OUTPUT RISE TIME

(10% TO 95% OF FINAL OUTPUT VALUE, @FULL LOAD)

115V-rms or 230V-rms
+ 3.3Vdc : 20ms Maximum
+ 5Vdc : 20ms Maximum
+ 12Vdc : 20ms Maximum
-12Vdc : 20ms Maximum
+ 5Vsb : 25ms Maximum

4.5. OVER VOLTAGE PROTECTION

Voltage Source	Protection Point
+3.3V	3.76V-4.8V
+5V	5.6V-7.0V
+12V	13.0V-15.6V

4.6.OVER-CURRENT PROTECTION

OUTPUT VOLTAGE	Max. overcurrent limit
+3.3V	50.0A
+5V	48.0A
+12V1 DC	22.0A
+12V2 DC	22.0A

4.7.SHORT CIRCUIT PROTECTION

Output short circuit is defined to be a short circuit load of less than 0.1 ohm.

In the event of an output short circuit condition on +3.3V, +5V or +12V output, the power supply will shutdown and latch off without damage to the power supply. The power supply shall return to normal operation after the short circuit has been removed and the power switch has been turned off for no more than 2 seconds.

In the event of an output short circuit condition on -12V output, the power supply will not be damaged. The power supply shall return to normal operation as soon as the short circuit has been removed. and the power switch has been turned off for no more than 2 seconds.

4.8. POWER SIGNAL

POWER GOOD @ 115/230V, FULL LOAD	100 – 500mSec.
POWER FAIL @115/230V, FULL LOAD	1 mSec. minimum

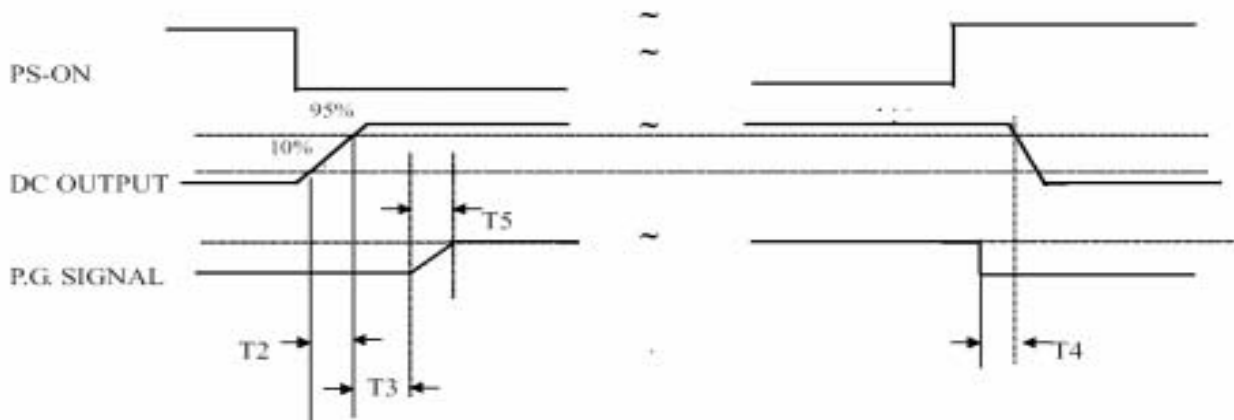

Figure 1

T2 : RISE TIME < 20mS

T3 : POWER GOOD DELAY TIME 100mS-500mS

T4 : POWER FAIL DELAY TIME > 1mS

T5 : POWER GOOD RISE TIME ≤ 10mS

5.0 FAN NOISE REQUIREMENTS

5.1. The subject power supply is cooled by a self-contained, 120mm, 12VDC fan.

1. FAN NOISE

2. ENVIRONMENTAL REQUIREMENTS

AC INPUT	FULL (Table.1)	TYPICAL (Table.1)	LIGHT (Table.1)
115V	NOISE \leq 35dB	NOISE \leq 30dB	NOISE \leq 25dB
230V	NOISE \leq 35dB	NOISE \leq 30dB	NOISE \leq 25dB

The power supply will be compliant with each item in this specification for the following Environmental conditions.

6.1. TEMPERATURE RANGE

Operating	0 to +50 deg. C
Storage	-20 to +80 deg. C

6.2. HUMIDITY

Operating	5 -95% RH, Non-condensing
Storage	5 -95% RH, Non-condensing

6.3. VIBRATION

The subject power supply will withstand the following imposed conditions without experiencing non-recoverable failure or deviation from specified output characteristics.

Vibration Operating – Sine wave excited, 0.25 G maximum acceleration, 10-250 Hz swept at one octave / min. Fifteen minute dwell at all resonant points, where resonance is defined as those exciting frequencies at which the device under test experiences excursions two times large than non-resonant excursions.

Plane of vibration to be along three mutually perpendicular axes.

6.4 GROUND LEAKAGE CURRENT

The power supply ground leakage current shall be less than 3.5 mA.

6.5 RELIABILITY

The power supply reliability, when calculated by MIL-HDBK-217; latest revision, are exceed 100,000 hours with

all output at maximum load and an ambient temperature of 25°C.

6.6 DIELECTRIC STRENGTH

Primary to Frame Ground : 1800 Vac for 1 sec. Primary to
Secondary : 1800Vac for 1 sec

6.7 INSULATION RESISTANCE

Primary to Frame Ground : 20 Meg.ohms Minimum Primary to
Secondary : 20 Meg.ohms Minimum

7.0. LABELLING

Label marking will be permanent, legible and complied with all agency requirements.

7.1. MODEL NUMBER LABEL Labels will be affixed to the sides of the power supply showing the following:

- Manufacturer's name and logo.

- Model no., serial no., revision level, location of manufacturer.

- The total power output and the maximum load for each output.

- AC input rating.

Note: This equipment has been tested and found to comply with the limits for a Class B digital device, pursuant to part 15 of the FCC Rules. These limits are designed to provide reasonable protection against harmful interference in a residential installation. This equipment generates, uses and can radiate radio frequency energy and, if not installed and used in accordance with the instructions, may cause harmful interference to radio communications. However, there is no guarantee that interference will not occur in a particular installation. If this equipment does cause harmful interference to radio or television reception, which can be determined by turning the equipment off and on, the user is encouraged to try to correct the interference by one or more of the following measures:

- Ⓒ Reorient or relocate the receiving antenna.
- Ⓒ Increase the separation between the equipment and receiver.
- Ⓒ Connect the equipment into an outlet on a circuit different from that to which the receiver is connected.
- Ⓒ Consult the dealer or an experienced radio/TV technician for help.

Modifications not expressly approved by the manufacturer could void the user's authority to operate the equipment under FCC rules.