

Battery Life

Extend battery life by switching off when not in use.

Interference

Advisable not to use vehicle close to high tension wires or CB radios.

HINTS FOR MAINTENANCE

Radio waves interference may affect behaviour of the vehicle. Special care for your vehicle is mentioned below.

Do not abuse your vehicle.

Radio waves interference may affect behaviour of the vehicle. Special care for your vehicle is mentioned below. Do not abuse your vehicle.

- Avoid heat, water, sand and high impact collisions. Off road vehicles run easily on grassy surfaces.
- Avoid using vehicle on wet surfaces or rain.
- Avoid using vehicle on sandy or dusty areas.
- Avoid using vehicle for long periods under direct sunlight. Sunlight or excessive heat may damage sensitive / electronic instruments.
- Store vehicle transmitter in dry cool places away from heaters or warm areas.
- Collision with hard surface may damage vehicle.
- Vehicle will not perform on thick carpet or dusty floors.
- Avoid running two vehicles of the same frequency (Purchase two vehicles with different frequencies instead.)
- Always brush your vehicle after use to remove dust. Keep vehicle clean.
- Always wipe vehicle with soft rag or cloth. Avoid cleaning vehicle with water or any chemicals

TROUBLE SHOOTING AND CARE FOR R/C VEHICLES

PROBLEM! VEHICLE DOES NOT MOVE

- Are the + and - contacts correctly matched in transmitter?
- Are the metal contact tabs touching, rusty or dirty in transmitter?
- Are there batteries in transmitter?
- Is the power switch on transmitter turned on?
- Is the battery weak or out of power?

TIME TO CHARGE!

Built in rechargeable battery is uncharged when new. Batteries lose all power at once. Your vehicle will suddenly stop. If this is the case, the vehicle is not defective, it had just run out of power.

Warning:

Changes or modifications to this unit not expressly approved by the party responsible for compliance could void the user's authority to operate the equipment

NOTE: This equipment has been tested and found to comply with the limits for a Class B digital device, pursuant to Part 15 of FCC Rules and R&TTE Directive 1999/5/EC. These limits are designed to provide reasonable protection against harmful interference in a residential installation. This equipment generates, uses and can radiate radio frequency energy and, if not installed and used in accordance with the instructions, may cause harmful interference to the radio communications.

However, there is no guarantee that interference will not occur in a particular installation. If this equipment does cause harmful interference to radio or television reception, which can be determined by turning the equipment off and on, the user is encouraged to try to correct the interference by one or more of the following measures:

- Reorient or relocate the receiving antenna.
- Increase the separation between the equipment and receiver.
- Connect the equipment into an outlet on a circuit different from that to which the receiver is needed.
- Consult the dealer or an experienced radio/TV technician for help.

THIS PRODUCT IS FOR THE USE IN U.K., SPAIN, GERMANY, FRANCE, BELGIUM, ITALY, SWITZERLAND, THE NETHERLANDS, DENMARK, U.S., CANADA AND PORTUGAL



CE0197

printed in china

Another Quality Product From



NO.8390
©ZAPTOYS 2002
MADE IN CHINA
REV 1 1202

Range

When vehicle loses battery radio signal contact, loss of control or slowness will occur.

Extend transmit antenna higher for re-contact.

Ensure antenna is screwed on tightly.

RADIO CONTROL

FULL FUNCTION

For over 5 years of age



Mini Crashers

8390

Instruction Manual

PLEASE ENSURE TO REMOVE ALL ACCESSORIES AND COMPONENTS FROM THE PACKAGING

How to Operate:

Charger

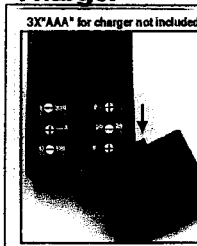

Charging battery:

The car has built in rechargeable battery. Put 3 x 1.5V AAA batteries into the charger with correct polarity, then place the car in the charger. The LED light on the charger will be turned on and the car is now charging. Once the car is fully charged, the LED light will be turned off automatically. The car is now ready to run.

- Remarks:
1. The charging time is 60 - 80 seconds.
 2. Recommend to use alkaline batteries for best performance.

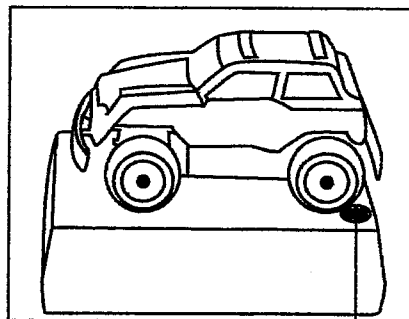

LED Light

After charging, pull back the car and release

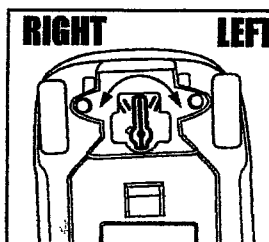
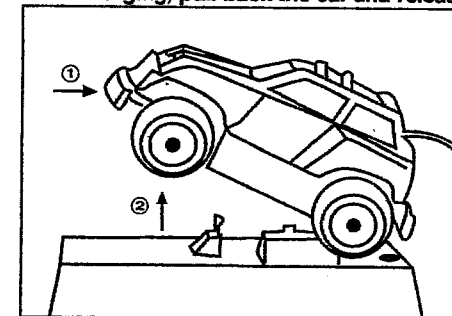

TRIM SWITCH CONTROL

The switch is located on the underside of the vehicle, between the two front wheels and is used to align the wheels for consistent straight line driving.

1/16/03

TRANSMITTER BATTERY INSTALLATION AND ASSEMBLY

- A. Insert 3X"AAA" battery matching + and - signs.
- B. In a clockwise direction, screw the threaded end of antenna into cavity located on top of transmitter. Ensure antenna is tightly screwed for good transmission.

3X"AAA" for transmitter not included

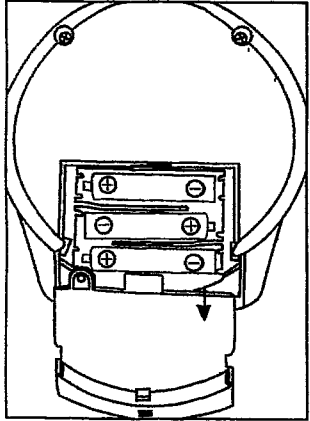

A.

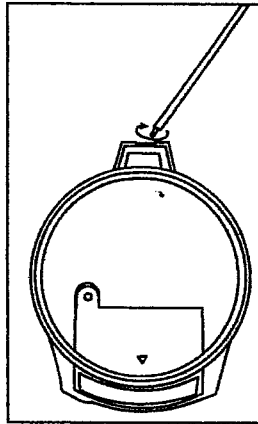

B.

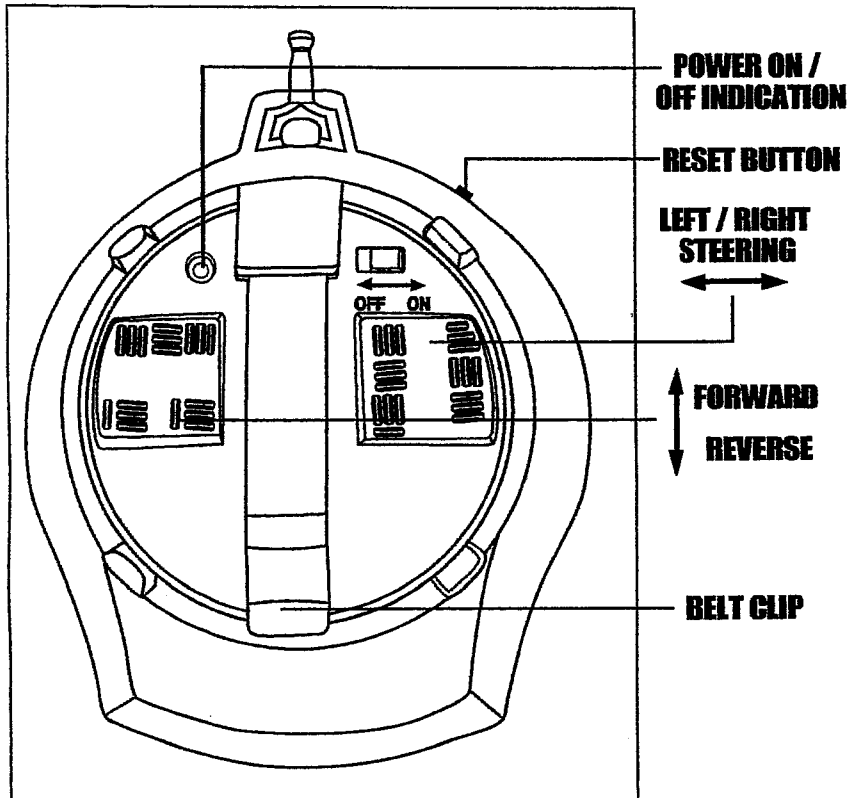

HOW TO PLAY

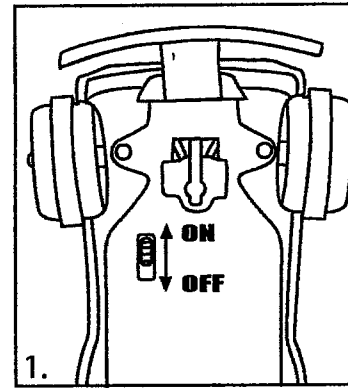

1.

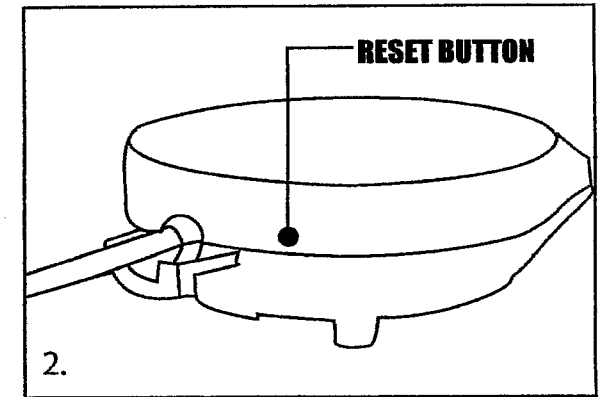

2.

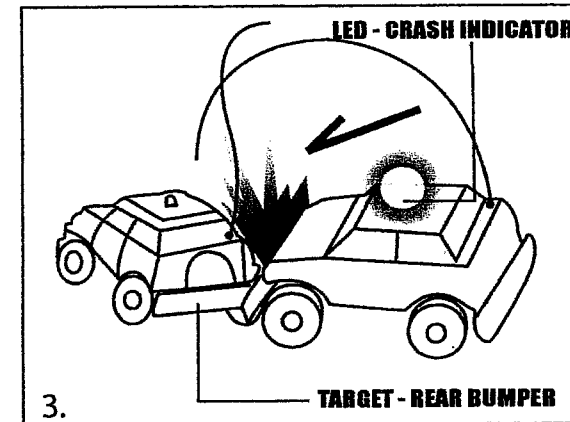

3.

1. After charge up the battery of the car, turn the switch "ON" for the car.
2. Turn the switch "ON" for the controller, push the "RESET" button, then the car will start with the engine sound and the LED - CRASH INDICATOR on the car is on.
3. Try to control the car by using the controller and hit the opponent's target - rear bumper. After the rear bumper is hit by 5 times, the LED of that car will be off and it will stop all the functions also.
4. To re-start the game, turn the switch of the car to "OFF" position then to "ON" again, also press the "RESET" button on the controller.
5. Sometimes the car will be off without being hit by 5 times, it is due to the car is out of battery, please recharge the car and restart the game.