

Motorola Solutions Inc.										
Title: 148603 Specification and Integration Guide										
Description/Abstract/Synopsis: The purpose of this document is to provide an integration guide targeted for module integrators who have an NDA with Motorola Solutions.										
	A	Document Status: In Progress								
MPA Document Number: NA	Division: MCD	<input type="checkbox"/> – Released Version <input type="checkbox"/> – Next Release In Process <input type="checkbox"/> – Document Obsolete Obsolete Document Replaced By:								
Working Revision: 20110610-i	Sub-team: RF-SYS	Obsolete Document Replaced By: N/A								
Last Updated: 01/18/2012	Document Type: SPEC / IG									
Confidentiality Statement: Classification: N/A <input type="checkbox"/> - Contains Motorola Solutions partner NDA related material (Disclosure requires a three-way NDA.)										
<table border="1" style="width: 100%; border-collapse: collapse;"> <thead> <tr> <th style="width: 50%;">Partner Name</th> <th style="width: 50%;">Agreement Number</th> </tr> </thead> <tbody> <tr> <td>USI</td> <td>Under NDA and Motorola Corporate Supply Agreement between Motorola Solutions and USI</td> </tr> <tr> <td> </td> <td> </td> </tr> <tr> <td> </td> <td> </td> </tr> </tbody> </table>			Partner Name	Agreement Number	USI	Under NDA and Motorola Corporate Supply Agreement between Motorola Solutions and USI				
Partner Name	Agreement Number									
USI	Under NDA and Motorola Corporate Supply Agreement between Motorola Solutions and USI									
<input type="checkbox"/> - For Motorola Solutions Internal Use Only <input checked="" type="checkbox"/> - Disclosure allowed under Motorola Solutions NDA Only <input checked="" type="checkbox"/> - Does or may contain Motorola Solutions patentable property *** Direct this document's disclosure inquires to (Job Title):										
TNT Archive Location/Path: Agile										
Current Owner:										
Authors / Contributors:										

Revision History

Rev #	Author	Date	Notes

Supporting or Reference Documentation	
MPA or Motorola Solutions Document Number	Title

Release Signatures Required	
Divisional Role	Motorola Solutions Associate

Copyright Information

No part of this document may be reproduced, stored in or introduced into a retrieval system, or transmitted in any form or by any means (electronic, mechanical, photocopying, recording, or otherwise) for any purposes, without the express written permission of Motorola Solutions, Inc.

Motorola Solutions, Inc. may have patents, patent applications, trademarks, copyrights, or other intellectual property rights covering subject matter in this document. Except as expressly provided in any written license agreement from Motorola Solutions, Inc., the furnishing of this document does not give you any express or implied rights to these patents, trademarks, copyrights, or other intellectual property.

© 2011 Motorola Solutions, Incorporated. All rights reserved.

Table of Contents

1. INTRODUCTION	6
1.1. BACKGROUND	6
1.2. GENERAL NOTE	6
1.3. PURPOSE	6
1.4. PART NUMBERS	6
2. ARCHITECTURE	7
2.1. WLAN	7
2.1.1. HOST COMMUNICATIONS	7
2.2. BLUETOOTH	7
2.3. GPS	9
2.4. POWER SUB-SYSTEM	9
3. SIGNAL DESCRIPTIONS	10
3.1. SIGNAL DESCRIPTIONS	10
3.1. PIN LAYOUT	13
4. DESIGN GUIDELINES AND RECOMMENDATIONS	14
4.1. TYPICAL APPLICATION SCHEMATIC	14
4.2. HOST PCB LAYOUT RECOMMENDATIONS	17
5. HOST REQUIREMENTS	18
5.1. ELECTRICAL POWER	18
5.2. ENVIRONMENTAL	18
5.2.1. ABSOLUTE MAXIMUM RATINGS	18
5.2.2. NORMAL OPERATING CONDITIONS	19
5.4. TIMING REQUIREMENTS	21
5.4.1. POWER UP TIMING	21
5.4.1.1. WLAN	21
5.4.1.2. BT/GPS/FM	21
5.4.2. SDIO TIMING REQUIREMENTS	22
5.4.2.1. SDIO DATA SWITCHING CHARACTERISTICS	22
5.4.2.2. SDIO DATA SWITCHING CHARACTERISTICS	22
5.4.2.3. SDIO SWITCHING CHARACTERISTICS	23
5.5. ANTENNA REQUIREMENTS	24

5.5.1.	WLAN	24
5.5.2.	BT	24
5.5.3.	GPS	25
6.	MODULE SPECIFICATIONS	26
6.1.	POWER CONSUMPTION	26
6.1.1.	WLAN POWER CONSUMPTION	27
6.1.2.	BT POWER CONSUMPTION	28
6.1.3.	GPS POWER CONSUMPTION	28
7.	APPENDIX	29
7.1.	RECOMMENDED HOST PCB PASTEMASK	29
7.2.	MECHANICAL INTERFACE DRAWING	30
7.3.	REGULATORY	30
7.3.1.	CE REGULATIONS	30
7.3.2.	FCC REGULATIONS	31
7.3.3.	IC REGULATIONS	33

Table of Figures

Figure 1 - Pin Map	13
Figure 2 – TOP VIEW Recommended Option 3) Solid ground beneath the specific module areas	17
Figure 3 - Recommended host PCB PasteMask	29

Table of Tables

Table 1 - Module Part Numbers and Description	6
Table 2 – Signal Descriptions.....	10
Table 3 - Typical Application Schematic BOM	15
Table 4 - Absolute Maximum Ratings.....	18
Table 5 - Normal Operating Conditions	19
Table 6 - Slow Clock Requirements	20
Table 7 - SDIO Single Block Read	22
Table 8 - SDIO Interface Read.....	22
Table 9 - SDIO Single Block Write	22
Table 10 -SDIO Interface Write	22
Table 11 – SDIO Timing.....	23
Table 12 - SDIO Timing.....	23

Table 13 - WLAN Antenna Requirements 24
Table 14 - Bluetooth Antenna Requirements 24
Table 15 - GPS Antenna Requirements 25
Table 16 - Hardware Low Power Mode - Module Shutdown (SDWN) Current Draw..... 26
Table 17 - BT Power Consumption 28
Table 18 - GPS Power Consumption 28

1. Introduction

1.1. Background

148603 is a radio module that will provide Wireless Local Area Network (WLAN) Bluetooth, GPS and FM features to Motorola Solutions' EMS products.

NOTE: FM is DISABLED in all revisions, and WLAN RF0 Path is not populated in the -01 and -02 versions.

1.2. General Note

This is a living document. Some descriptions are based on the current phase of the 148603 module design program. Changes to this document will occur without direct notification to its users. Users who wish to have the latest information should coordinate with the module team leader. The terms “preferred” and “recommend” are used throughout this document. Preferred can be thought of as a “nice-to-have” or “in-good practice”. The term “recommendation” should be taken as a stronger implementation guideline where if not implemented performance degradation may occur.

1.3. Purpose

The purpose of this document is to provide a guide targeted for module integrators who have an NDA with Motorola Solutions.

1.4. Part Numbers

Part Number	SKU
21-148603-01	Diversity version with WLAN and BT on SHARED RF paths
21-148603-02	Diversity version with WLAN and BT on SEPARATE RF paths
21-148603-03	NON-Diversity version with WLAN and BT on a SHARED RF path
21-148603-04	NON-Diversity version with WLAN and BT on SEPARATE RF paths

Table 1 - Module Part Numbers and Description

2. Architecture

2.1. WLAN

2.1.1. Host Communications

The WLAN core requires a total of eight (8) dedicated signals in order to communicate to the host processor. The WLAN core is enabled via the WL_EN signal (1) and communicates to the host processor via SDIO (6) with an additional interrupt signal WL_IRQ(1).

2.1.1.1. Hardware Interface

The interface between the host and the 148603 Module is a standard SDIO interface (see SDIO spec version 2.0), supporting maximum clock rate of 52MHz.

The WL1281/3 SDIO also supports the following features:

- Both 1 and 4 bit data bus
- Abort command
- Multi-Block data transfer
- The SDIO interface is used for WLAN IP only.
- The SDIO interface supports High Speed protocol.

2.2. Bluetooth

2.2.1. Host Communications

The Bluetooth subsystem requires nine (9) connections to the host in order for full operation, including PCM (4), High-Speed UART (4) and BT_GPS_FM_EN (1) , which shall be connected to the host to enable the Bluetooth IP. It should also be noted that an additional line from the WL1283 can be used for debug purposes, namely BT_UART_DBG.

2.2.1.1. Hardware Interface

2.2.1.1.1. HCI UART Transport layers

The HCI UART Supports 4-wire UART interface to host. Supports most baud rates for all fast clock frequencies, up to a maximum of 4Mbps. Default baud rate after power up is 115.kkpbs with a deviation of +1.5%, -2.5%, until baud is changed via a vendor specific command.

- BT_GPS_FM_TX
- BT_GPS_FM_RX
- BT_GPS_FM_RTS
- BT_GPS_FM_CTS

2.2.1.1.2. PCM Audio

PCM audio interface to the host uses the following signals:

In Slave mode, input frequencies up to 16MHz supported. In master mode, the TI1283 can generate any clock frequency between 64KHz and 4.096MHz.

- BT_PCM_OUT
- BT_PCM_IN
- BT_PCM_SYNC
- BT_PCM_CLK

The BT Audio Codec has a fully dedicated programmable serial port

- Two voice channels
- Supports Master/slave modes
- u-law, a-law, linear and transparent coding schemes
- Long and short frames
- Different data sizes, order and positions
- UDI profile
- High rate PCM

2.2.2. Power Class

148603 supports up to Power Class 1.5 Operation.

2.2.3. 148603 BT RF Paths

The 148603 design will be the first internal module to integrate a PTA and selection diversity antenna structure over the same RF paths. Due to the development cycle and schedule, at the time of the release of the module's engineering design, this timing was not fully understood. Consequently, the 148603 team designed in a provision that would allow the BT RF to be available through a separate RF port. Should this population option need to be used, external matching and filtering would be required and support from the 148603 module team should be sought when implementing this option.

- **IMPORTANT NOTE: A tradeoff performance evaluation is currently being conducted to demonstrate the ability to break-out the BT RF from the WL1283 to the 148603 Module pins, bypassing the FEM and disabling PTA.**

2.3. GPS

The GPS hardware interface shares the BT UART hardware interface as described in Section **Error! Reference source not found.**. On power up, the core is disabled by default and will remain in this state until host enables it by setting BT_GPS_FM_EN and writing Vendor Specific commands to turn on GPS via the shared transport.

2.4. Power Sub-System

The 148603 requires two external voltage sources a VBAT=3.3V nominal and a VIO=1.8V nominal. The VBAT is used to supply voltage to the SoC, FEM, and antenna selection control logic. The VIO is used to supply voltage to the SoC and provide level detection to the antenna switch control logic. The SoC incorporates an internal 1.8V that is used to supply the internal Soc 1.8V rail as well as power to the 26MHz TCXO.

2.5. Internal Clock Frequencies

The 148603 has on-module TCXO operating at 26MHz

2.5.1. WLAN

WLAN has an Zero-IF architecture and thus the LO operates at ~10GHz that is divided by 2 for 5G Band operation and divided by 4 for 2.4GHz Band operation.

2.5.2. BT

The TCXO is used to produce the relevant BT channel, between 2.402G to 2.480GHz. The ADPLL produces the frequencies between 4.804GHz to 4.96GHz, which divided by 2 to provide the BT frequencies.

2.5.3. GPS

The LO frequency for GPS is 1579.5MHz.

2.5.4. FM

The FM IP generates the FM station frequency from the divided FREF clock or by the 32K clock. It is generated by the Synthesizer and ADPLL. The FM channel frequency band is between 76-108MHz (Europe and Japan).

NOTE: FM is DISABLED.

3. Signal Descriptions

3.1. Signal Descriptions

Listed below are the pin numbers and signals on the 148603 module.

GEN = General (No specific function), PWR= Power Supply, ANA= Analog

NOTE: FM is DISABLED in all revisions, and WLAN RF0 Path is not populated in the -01 and -02 versions.

Table 2 – Signal Descriptions

PIN DEFINE REV		0.02						
Module Pin Name	Pin #	I/O Type	Function	Connects to	SD State	Default State (after POR)	Buffer [mA]	Description
VBAT1	68	PWR	GEN	PWR				VBAT 3.3V Input
VBAT2	69	PWR	GEN	PWR				VBAT 3.3V Input
VBAT3	70	PWR	GEN	PWR				VBAT 3.3V Input
VBAT4	71	PWR	GEN	PWR				VBAT 3.3V Input
VIO1	16	PWR	GEN	PWR				VIO 1.8V Digital Voltage
VIO2	17	PWR	GEN	PWR				VIO 1.8V Digital Voltage
GND1	6	GND	GEN	GND				Ground Pin
GND3	8	GND	GEN	GND				Ground Pin
GND4	10	GND	GEN	GND				Ground Pin
GND5	11	GND	GEN	GND				Ground Pin
GND6	13	GND	GEN	GND				Ground Pin
GND7	14	GND	GEN	GND				Ground Pin
GND8	15	GND	GEN	GND				Ground Pin
GND9	18	GND	GEN	GND				Ground Pin
GND10	23	GND	GEN	GND				Ground Pin
GND11	30	GND	GEN	GND				Ground Pin
GND12	33	GND	GEN	GND				Ground Pin
GND13	36	GND	GEN	GND				Ground Pin
GND14	38	GND	GEN	GND				Ground Pin
GND15	41	GND	GEN	GND				Ground Pin
GND16	43	GND	GEN	GND				Ground Pin
GND17	46	GND	GEN	GND				Ground Pin
GND18	48	GND	GEN	GND				Ground Pin
GND19	50	GND	GEN	GND				Ground Pin
GND20	54	GND	GEN	GND				Ground Pin
GND21	60	GND	GEN	GND				Ground Pin
GND22	67	GND	GEN	GND				Ground Pin

GND23	72	GND	GEN	GND				Ground Pin
GND_H	73	GND	GEN	GND				Ground Pin Heat Sink Pad
WL_EN	32	IN	WLAN	HOST	PD	PD	N/A	WLAN IP enable (0=not active, 1=host enable WLAN IP)
SDIO_CLK	25	IN	WLAN	HOST	HiZ	HiZ	4	WLAN SDIO clock. Place signal conditioning resistor on SDIO_CLK close to host processor
SDIO_CMD	24	I/O	WLAN	HOST	HiZ	HiZ	8/6/4/2	SDIO command in. SDIO lines must be pulled up by the host.
SDIO_D0	26	I/O	WLAN	HOST	HiZ	HiZ	8/6/4/2	SDIO data bit 0. SDIO lines must be pulled up by the host.
SDIO_D3	28	I/O	WLAN	HOST	PD	HiZ	8/6/4/2	SDIO data bit 3. SDIO lines must be pulled up by the host.
SDIO_D1	29	I/O	WLAN	HOST	HiZ	HiZ	8/6/4/2	WLAN SDIO data bit 1. SDIO lines must be pulled up by the host.
SDIO_D2	27	I/O	WLAN	HOST	HiZ	HiZ	8/6/4/2	WLAN SDIO data bit 2 . SDIO lines must be pulled up by the host.
WLAN_IRQ	58	OUT	WLAN	HOST	PD	Drive 0	4	WLAN Interrupt out. Active low.
WL_RS232_TX	66	OUT	WLAN	DEBUG	PU	Drive 1	4	RTT tool UART output
WL_RS232_RX	65	IN	WLAN	DEBUG	PU	PU	4	RTT tool UART input
WL_UART_DBG	57	OUT	WLAN	DEBUG	PU	Drive 1	4	WLAN Logger output UART output
JTAG_TMS	62	IN	WLAN	DEBUG	PU	PU	4	JTAG Test Mode State Input
JTAG_TDO	61	OUT	WLAN	DEBUG	PU	Drive 1	4	JTAG Test Data Out Output
JTAG_TDI	64	IN	WLAN	DEBUG	PU	PU	4	JTAG Test Data In Input
JTAG_TCK	63	IN	WLAN	DEBUG	PD	PD	4	JTAG Test Clock Input
RF2	9	RF	WLAN/BT	ANT	RF			Default WLAN RF Port (Shared with BT using -01 Module Configuration) 50Ω Termination if not used.
RF1	12	RF	WLAN/BT	ANT	RF			Auxiliary WLAN RF Port (Shared with BT using -01 Module Configuration) 50Ω Termination if not used.
RF0	7	RF	GEN	GND	RF			Diversity Bypass Path. WLAN RF Port (Shared with BT using -03 Module Configuration) This path is mutually exclusive with RF1 and RF2. RF0 Path is not populated in the -01 and -02 versions. 50Ω Termination if not used.
BT_GPS_FM_EN	53	IN	BT/GPS/FM	HOST	PD*	PD*	N/A	Bluetooth IP enable (0=not active, 1= host enable Bluetooth IP (GPS and FM active through VS commands)
BT_GPS_FM_TX	19	OUT	BT/GPS/FM	HOST	PU	Drive 1	4	HCI UART transmit output
BT_GPS_FM_RX	20	IN	BT/GPS/FM	HOST	PU	PU	4	HCI UART receive input
BT_GPS_FM_CTS	21	IN	BT/GPS/FM	HOST	PU	PU	4	HCI UART clear to send input (active low)
BT_GPS_FM_RTS	22	OUT	BT/GPS/FM	HOST	PU	Drive 1	4	HCI UART request to send (active low). Signal IRQ asserted until cleared by host.

BT_PCM_CLK	2	I/O	BT	HOST	PD	PD	8/6/4/2	Bluetooth PCM clock in or out. Data can be driven out on rising edge or falling edge. Data can be sampled on rising edge or falling edge.
BT_PCM_SYNC	3	I/O	BT	HOST	PD	PD	8/6/4/2	Bluetooth PCM frame sync in or out.
BT_PCM_IN	4	IN	BT	HOST	PD	PD	8/6/4/2	Bluetooth PCM data.
BT_PCM_OUT	1	OUT	BT	HOST	PD	PD	8/6/4/2	Bluetooth PCM Data out.
BT_RF	49	RF	BT	ANT	RF			BT RF Port (Using -02 Module Configuration) 50Ω Termination if not used
BT_UART_DBG	5	OUT	BT	DEBUG	PU	PU	4	BT Logger output UART output
GPS_TIMESTAMP	56	IN	GPS	WWAN/ HOST	PD	PD	4	Time stamp from cellular clock or any reference clock used to calibrate TCXO
GPS_PA_EN	55	IN	GPS	WWAN	PD	PD	4	GPS PA enable can be used for possible WWAN coexistence. This input will "blank-out" GPS signal in the case where there is known jamming from WWAN module.
GPS_PPS_OUT	52	OUT	GPS	HOST	PD	PD	4	GPS Pulse per second strobe output
GPS_EXT_LNA_EN	51	OUT	GPS	GPS	PD	PD	4	GPS External LNA Enable output
GPS_RF	42	RF	GPS	ANT	RF			GPS RF input port 50Ω Termination if not used.
FM_RF_IN_P	37	RF	FM	ANT	RF			FM 50Ω Receive RF Input Port. 180nH external serial inductor required. 50Ω Termination if not used.
FM_RF_OUT_P	34	RF	FM	ANT	RF			FM Transmit RF Plus Differential Output Port. No Connect if not used
FM_RF_OUT_M	35	RF	FM	ANT	RF			FM Transmit RF Minus Differential Output Port. No Connect if not used
FM_AUD_IN_L	40	ANA	FM	HOST	ANA			FM Audio Left Input Requires external serial 0.22uF cap if used. GND if not used.
FM_AUD_IN_R	39	ANA	FM	HOST	ANA			FM Audio Right Input Requires external serial 0.22uF cap if used. GND if not used.
FM_AUD_OUT_L	44	ANA	FM	HOST	ANA			FM Audio Left Output Requires external serial 0.22uF cap if used. No Connect if not used
FM_AUD_OUT_R	45	ANA	FM	HOST	ANA			FM Audio Right Output Requires external serial 0.22uF cap if used. No Connect if not used
SLOW_CLK	47	ANA	GEN	HOST	ANA			32.768KHz Slow CLK input. See Sec. 0
GPIO_WL_BT_N7	31	I/O	GEN	TP	PD	PD	4	Spare GPIO. Can be used by the WL and BT IP's
GPIO_WL_BT_GPS_M8	59	I/O	GEN	TP	PU	PU	4	Spare GPIO. Can be used by the WL, BT, and GPS IP's

148603 Specification and Integration Guide

3.1. Pin Layout

Pin layout has been optimized for RF performance, heat dissipation, Voltage drop, signal route, host signal connections, module size, and manufacturability.

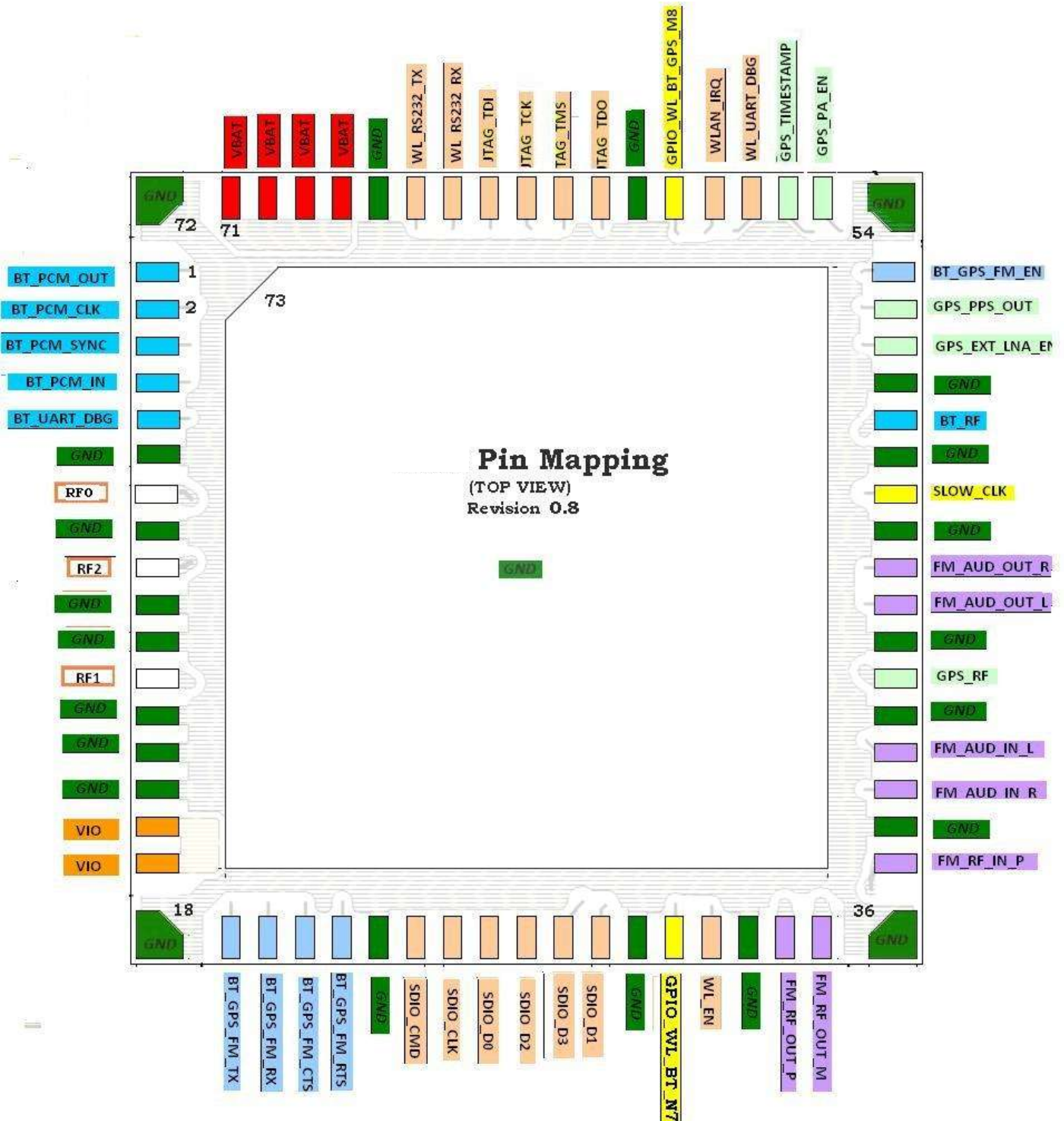

Figure 1 - Pin Map

4. Design Guidelines and Recommendations

4.1. Typical Application Schematic

General Note: This typical application schematic and BOM has not been updated to reflect the addition of RF0 and the associated part numbers in the Section 1.4. As such, **please use the latest MPA3 platform schematics**. This section(4.1) is superseded by Section 1.4 and the MPA3 controlled schematics.

NOTE: FM is DISABLED in all revisions, and WLAN RF0 Path is not populated in the -01 and -02 versions.

An application schematic has been created for the MPA3 platform and is controlled outside of this document. Schematic-function-blocks have been created for each sub-function such as optional BT and FM.

Shown on page 16 is a typical application schematic for the 148603 module with all schematic blocks for both the -01 and -02 module versions. Listed below Table 3 is the bill of materials (BOM) for the Application Schematic.

- **IMPORTANT NOTE: SDIO lines must be pulled up by the host.**
- Place signal conditioning resistor on SDIO_CLK close to host processor.

Table 3 - Typical Application Schematic BOM

Motorola Part Number	Qty	Ref Designator
21-144290-02	1	U2
50-11500-458	2	C10,C17
50-11500-471	1	C9
50-11568-25K102	1	C25
50-11568-25K471	2	C13,C14
50-11573-10K104	3	C11,C16,C21
50-11578-25J100	1	C29
50-11578-25J470	3	C12,C15,C24
50-11800-542	2	L3,L4
50-11800-563	1	L2
50-11800-715	1	L1
50-11800-717	2	L5,L11
50-11824-2R7	2	L8,L9
50-11828-510	2	L6,L7
50-12700-167	1	FL1
50-12700-168	1	U3
50-13130-3981	1	U1
50-14714-1000	1	R20
50-14725-2701	1	R22
50-14726-000	18	R1-R12, R17-R19,R21,R23,R24
50-15600-072	1	T1
50-21815-181	1	L10
NOT_USED	22	C1-C8,C18-C20,C22,C23,C26-C28,C30,C31,R13-R16

148603 WL1283 PRODUCT SCHEMATIC

REVISIONS				
REV	DATE	DESCRIPTION	E.C.	BY
1		SEE SHEET 1		

DEDICATED BT ANTENNA OPTION

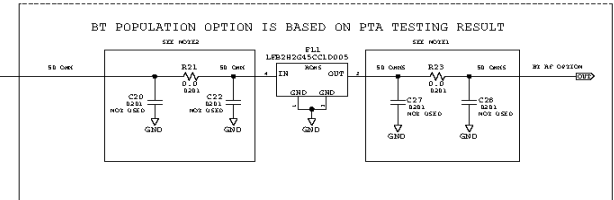

GPS RF

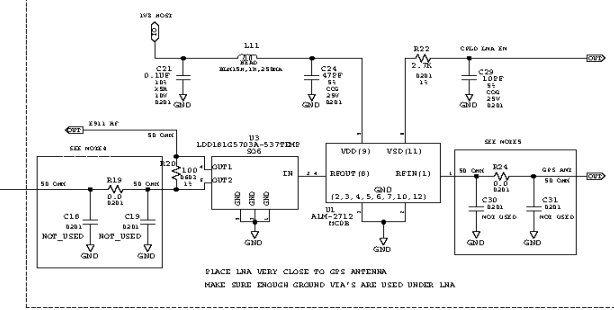

FM_RF_RX

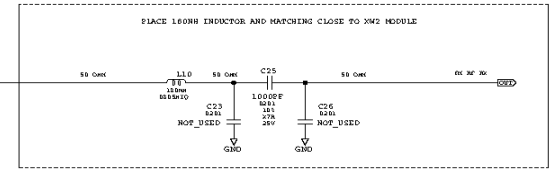

FM RF TX

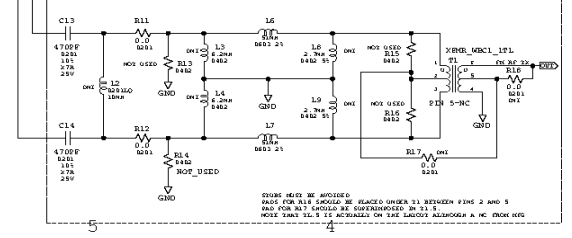

WLAN RF

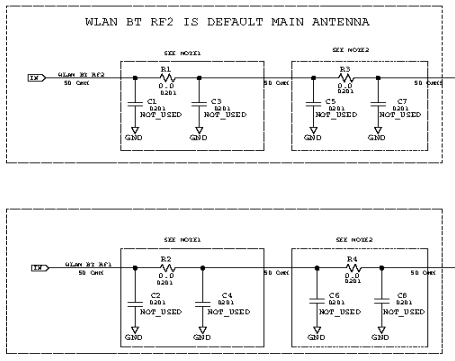

- NOTES:
- NOTE1: OPTIONAL FOR PRODUCT IMPLEMENTATION, PLACE IS CLOSER TO ANTENNA
 - NOTE2: REPLACE MATCHING COMPONENTS CLOSER TO 342 MODULE
 - NOTE3: KEEP 0 OHM RESISTOR CLOSE TO 342 MODULE
 - NOTE4: ACTUAL VALUE IS DEPENDENT ON PRODUCT IMPLEMENTATION
 - NOTE5: OPTIONAL FOR PRODUCT IMPLEMENTATION, PLACE IS CLOSER TO ANTENNA
 - NOTE6: REPLACE MATCHING COMPONENTS CLOSER TO 342 MODULE
 - NOTE7: GROUND PIN AND IN L AND IN AND IN R IF IN IS NOT USED.

REVISION HISTORY

REV	DATE	DESCRIPTION	E.C.	BY
1		SEE SHEET 1		

4.2. Host PCB Layout Recommendations

4.2.1. Recommended Footprint and Solder Paste

The latest part symbol should be always be refreshed from the Motorola Solution part libraries. See Appendix

for the Recommended Host PCB Footprint/Pastemask.

The Allegro Footprint (.dra) is also available.

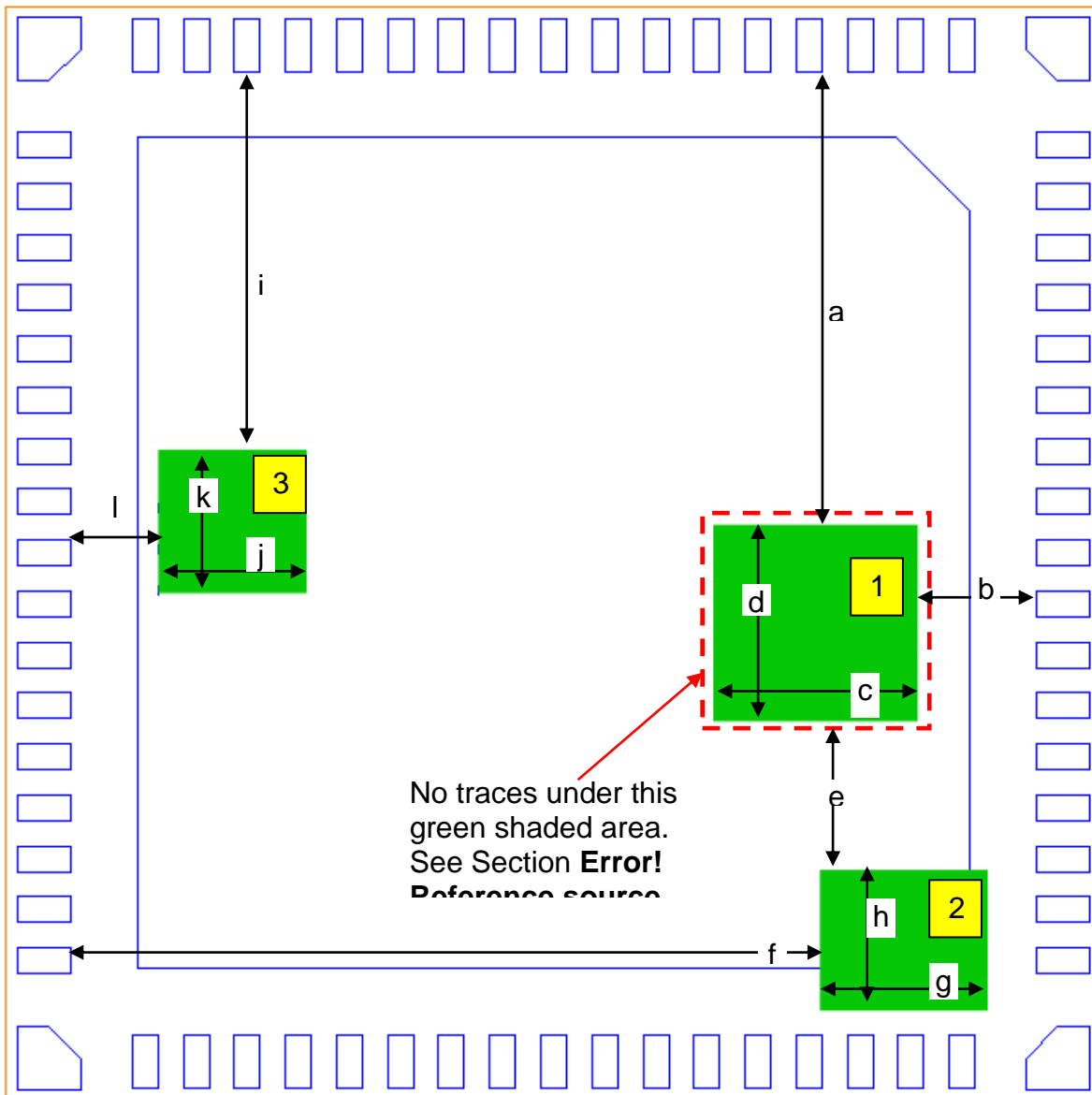

Figure 2 – TOP VIEW Recommended Option 3) Solid ground beneath the specific module areas

5. Host Requirements

5.1. Electrical Power

V_{BAT} = 3.3V ±10%, with a ripple of 25mV_{RMS} (Sine wave 10 Hz to 5 MHz)

V_{IO} = 1.8V ±5%, with a ripple of 25mV_{RMS} (Sine wave 10 Hz to 5 MHz)

5.2. Environmental

5.2.1. Absolute Maximum Ratings

Stresses beyond those listed in Table 4 below may cause permanent damage to the device. These are stress ratings only and the functional operation of the device at these or any other conditions beyond those indicated under Table 5 - Normal Operating Conditions” is not implied. Exposure to absolute-maximum-rated conditions for extended periods may affect device reliability.

Rating	Condition	Min	Max	Unit
V _{BAT} power supply voltage	Absolute Max Voltage up to 6 hours cumulative in 7 years.	-0.5	5.5	V
V _{IO} power supply voltage		-0.5	2.1	V
Input voltage to Analog pins	FM_RF_IN_P, FM_AUD_IN_L, FM_AUD_IN_R FM_AUD_OUT_L, FM_AUD_OUT_R	-0.5	2.1	V
Input voltage to all other pins		-0.5	V _{IO} +0.5V	V
Operating ambient temperature range	Absolute Minimum driven by TCXO	-30	85	°C
Storage temperature range	Absolute Max driven by TCXO	-40	85	°C

Table 4 - Absolute Maximum Ratings

5.2.2. Normal Operating Conditions

Rating	Condition	Sym	Min	Typ	Max	Unit
VBAT power supply voltage			3	3.3	3.6	V
VIO power supply voltage			1.71	1.8	1.89	V
VBAT Maximum ripple	Sine wave 10 Hz to 5 MHz				25	mVrms
VIO Maximum ripple	Sine wave 10 Hz to 5 MHz				25	mVrms
VIO High-level input voltage	Default	VIH	0.65 x VIO		VIO	V
VIO Low-level input voltage	Default	VIL	0		0.35 x VIO	V
High-level output voltage	@ 4 mA	VOH	VIO - 0.45		VIO	V
	@ 1 mA		VIO - 0.112		VIO	V
	@ 0.3 mA		VIO - 0.033		VIO	V
Low-level output voltage	@ 4 mA	VOL	0		0.45	V
	@ 1 mA		0		0.112	V
	@ 0.09 mA		0		0.01	V
Input transitions time Tr/Tf from 10% to 90% (Digital IO) (1)		Tr/Tf	1		10	nS
Output rise time from 10% to 90% (Digital pins) (1)	CL < 25 pF	Tr			5.3	ns
Output fall time from 10% to 90% (Digital pins) (1)	CL < 25 pF	Tf			4.9	ns
Ambient operating temperature (installed environment)			-20		+70	°C
Storage temperature (installed environment)			-40		+85	°C
Pull currents All except WL_EN, BT_GPS_FM_EN, (For these typ = 6uA)			110		190	uA

(1) Applies to all Digital lines except SDIO, UART, and SLW_CLK lines

Table 5 - Normal Operating Conditions

5.3. External Slow Clock (32K) Requirement

The supported digital slow clock is a free-running clock of 32.768 KHz which is supplied from an external clock source. It shall be connected to the SLOW_CLK pin and is a digital square-wave signal in the range of 0-1.8V Nom. See Table 2 above on page 10 for module pin number. All four core functions share a single input. Refer to * If the available slow clock source does not meet the 40 ppm requirement, there are two options;

- Use the fast clock for the FM_TX functionality. This is configured using a vendor-specific command to switch to Fref operation after enabling the FM core with the slow clock source.
- Enable clock error calibration in the FM core to compensate for the clock source error. The calibration can be done using a known vendor-input clock error or intrinsically to the core (self-calibration).

Table 6 - Slow Clock Requirements below for slow clock specifications. SLOW_CLK is a "fail-safe" input and can support an external clock voltage on the module pin even when no power is supplied to the module. See **Error! Reference source not found.** **Error! Reference source not found.** for the SLOW_CLK input requirements.

Characteristics	Condition	Sym	Min.	Typ.	Max.	Unit
Input slow clock frequency				32768		Hz
Input slow clock accuracy (Initial + temp + aging)	WLAN, BT				±250	ppm
	GPS				±200	
	FM_RX				±150	
	FM_TX *				±40	
Input transition time Tr/Tf -10% to 90%		Tr/Tf			100	ns
Frequency input duty cycle			15	50	85	%
Input voltage limits	Square wave, DC-coupled	Vih	0.65 x VIO		VIO	Vpeak
		Vil	0		0.35 x VIO	
Input impedance			1			MΩ
Input capacitance					5	pF
Phase noise	1 kHz , 10 kHz				-125	dBc/Hz
Jitter	Integrated over 300 - 15000 Hz				1Hz / 0.5nS	

* If the available slow clock source does not meet the 40 ppm requirement, there are two options;

- Use the fast clock for the FM_TX functionality. This is configured using a vendor-specific command to switch to Fref operation after enabling the FM core with the slow clock source.
- Enable clock error calibration in the FM core to compensate for the clock source error. The calibration can be done using a known vendor-input clock error or intrinsically to the core (self-calibration).

Table 6 - Slow Clock Requirements

5.4. Timing Requirements

5.4.1. Power Up Timing

5.4.1.1. WLAN

TBD

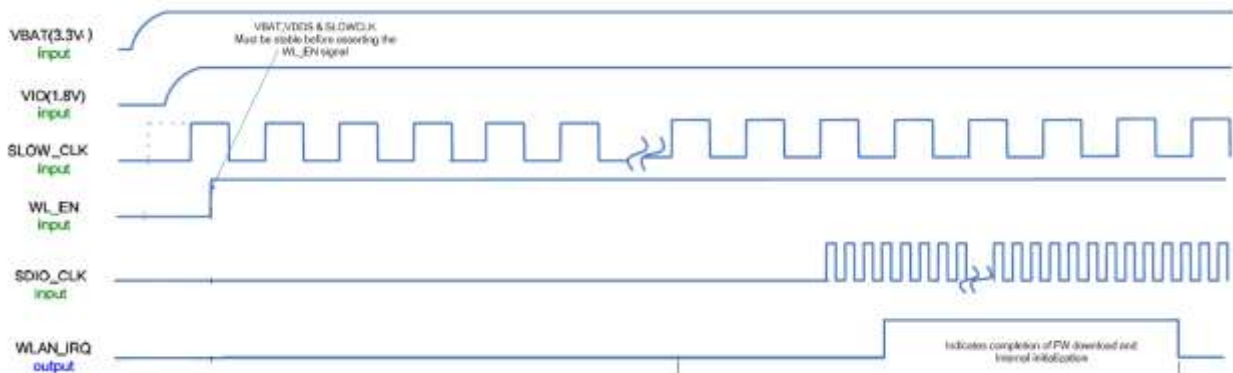

5.4.1.2. BT/GPS/FM

TBD

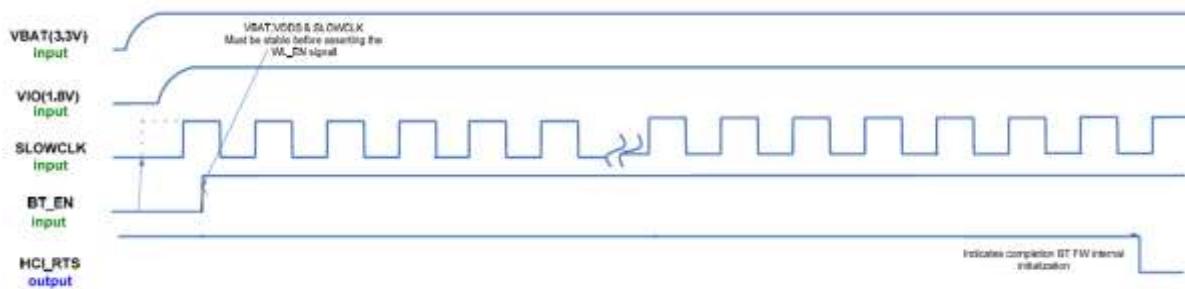

5.4.2. SDIO Timing Requirements

5.4.2.1. SDIO Data Switching Characteristics

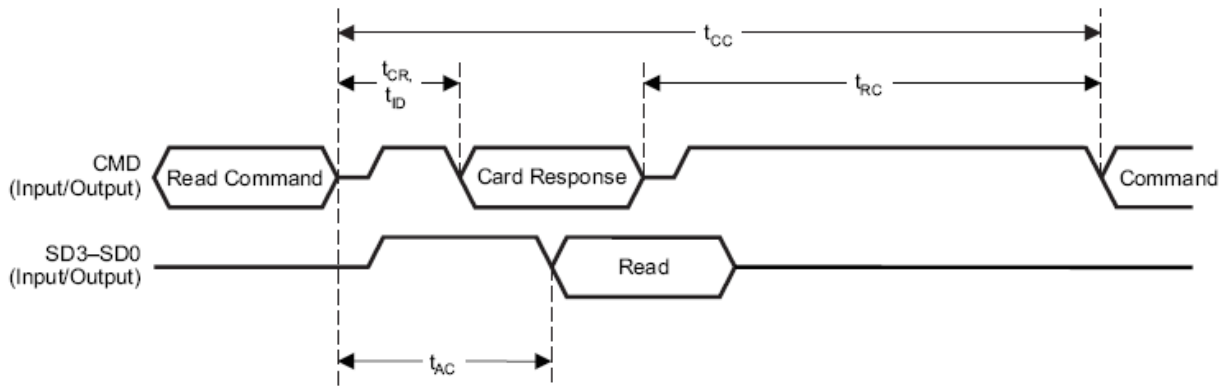
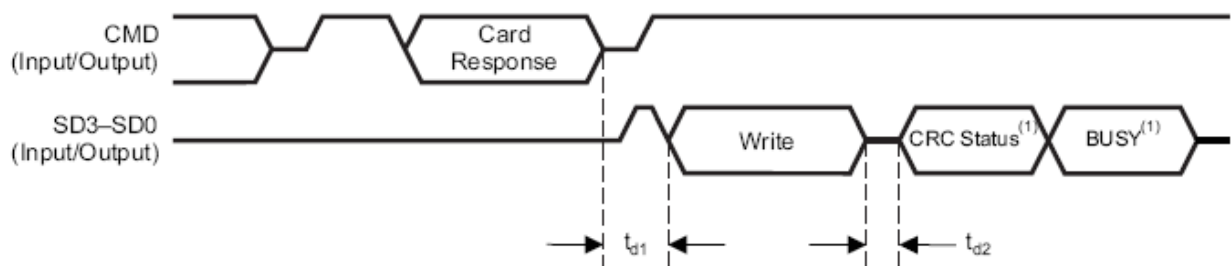

Table 7 - SDIO Single Block Read

Parameter	Sym	Min.	Max.	Unit
Delay time, assign relative address or data transfer mode / Read-command CMD valid to card-response CMD valid	tCR	2	64	Clock cycles
Delay time, CMD command valid to CMD command valid	tCC	58		Clock cycles
Delay time, CMD response valid to CMD command valid	tRC	8		Clock cycles
Access time, CMD command valid to SD3-SD0 read data valid	tAC	2		Clock cycles

Table 8 - SDIO Interface Read

5.4.2.2. SDIO Data Switching Characteristics



NOTE: CRC status and busy waveforms are only for data line 0. Data lines 1-3 are N/A. The busy waveform is optional, and may not be present.

Table 9 - SDIO Single Block Write

Parameter	Sym	Min.	Max.	Unit
Delay time, CMD card response invalid to SD3-SD0 write data valid	td1	2		Clock cycles
Delay time, SD3-SD0 write data invalid end to CRC status valid	td2	2	2	Clock cycles

Table 10 -SDIO Interface Write

5.4.2.3. SDIO Switching Characteristics

Over Recommended operating conditions
Parameters for maximum clock frequency

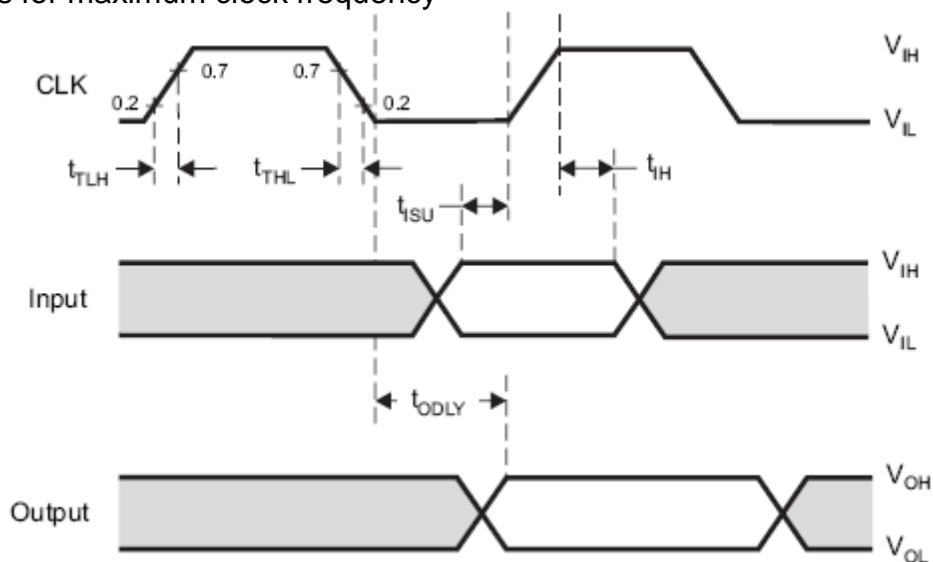

Table 11 – SDIO Timing

Parameter	Sym	Min.	Max.	Unit
Clock frequency, CLK Default Rate	fclock	0	26	MHz
Clock frequency, CLK High Rate	fclock	0	52	MHz
Low/high duty cycle	DC	40	60	%
Rise time, CLK	t_{TLH}	1	3	ns
Fall time, CLK	t_{THL}	1	3	ns
Setup time, input valid before CLK \uparrow	t_{ISU}	2		ns
Hold time, input valid after CLK \uparrow	t_{IH}	2		ns
Delay time, CLK \downarrow to output valid	t_{ODLY}	2.5	14.8	ns
Capacitive load on outputs	Cl		15	pF

Table 12 - SDIO Timing

5.5. Antenna Requirements

The following table summarizes the guidelines for the Antenna design:

5.5.1. WLAN

Description	Requirement	Comments
Frequency Bands		
Lower band	2.4 GHz to 2.5 GHz	Required for 802.11g support
Upper band	4.920 GHz to 5.825 GHz	Required for 802.11a support
Nominal Impedance	50 ohms	
VSWR	Less than 2.0:1	Across bands
Gain (Peak)	3dBi for the lower band	Does not include RF losses between 148603 radio and Antenna connector
	4dBi for the upper band	

Table 13 - WLAN Antenna Requirements

Regulatory Note: Many country regulations require special testing and reporting of antenna performance or of the system with the antenna attached. Please check the appropriate regulatory authority or contact Motorola Solutions for more information.

5.5.2. BT

If the BT antenna is being shared with WLAN, then the WLAN antenna requirements in Table 13 above supersede the requirements in this section.

If a standalone antenna for BT is being used then the requirements in Table 14 apply.

Description	Requirement	Comments
Frequency Band		
Bluetooth	2.4 GHz to 2.5 GHz	
Nominal Impedance	50 ohms	
VSWR	Less than 2.0:1	Across the Band

Table 14 - Bluetooth Antenna Requirements

5.5.3. GPS

Description	Requirement	Comments
Frequency Bands		
GPS	1575.42MHz ± 2MHz	
GLONASS*	1565MHz- 1606MHz	Although the 148603 does not support GLONASS it is recommended that the antenna is ready for future proofing
Nominal Impedance	50 ohms	
VSWR	Less than 2.0:1	

Table 15 - GPS Antenna Requirements

6. Module Specifications

6.1. Power Consumption

Hardware Low Power Mode - Module Shutdown (SDWN)

- *Description:* After VBAT and VIO are supplied to the module and while WLAN_EN and BT_GPS_FM_EN are de-asserted (LOW), the module is in Shutdown state. Open connections will be lost. Upon resume downloading firmware is necessary.
- *Requirements:*
 - SDIO lines should be held high by the host to prevent leakage.
 - Host clears all enables WL_EN & BT_GPS_FM_EN.
 - Host ensures all other IOs are in the correct state to prevent back-powering.

State	Comments	VBAT current (uA)			VIO current (uA)		
		Min.	Typ.	Max.	Min.	Typ.	Max.
Supply Voltage VBAT= 3.3V, VIO = 1.8V							
Shutdown	See Section 6.1		40			10	

Table 16 - Hardware Low Power Mode - Module Shutdown (SDWN) Current Draw

6.1.1. WLAN Power Consumption

- System Draws for MPA3 Guidance:
 - **Software Low Power Mode** – Extended Low Power Mode (**ELP**, RTTT=Sleep Mode)
 - *Description:* In this mode, MAC, PHY, and DRPw are in shutdown mode. The WL1283 SoC will not be able to receive packets. While in ELP mode, the WL1283 WLAN IP operates on slow clock only.
 - *Requirements:* Processor sends SDIO (or RTTT UART) commands to the WLAN core.
 - In case of critical suspend need to disable wake on WL_IRQ.
 - See **Error! Reference source not found.** on page **Error! Bookmark not defined.**
 - **Highest Current Mode**
 - VBAT :Transmitting CW 22dBm on 2.4GHz (This will change based on EV2 /DV results and the limitation in output power)
 - VIO: Loading FW
 - **Worst Case Suspend Mode** - Wake on LAN (WOWL)
 - *Description:* WAKE ON LAN is designed to block packets from going up from the firmware layer into the driver layer.
 - *Requirements:* The enabling of this feature requested two separate different commands.1. Enable the feature. 2. Configure the filter different variants. If the filter is activated and the user didn't define the filter variants, then all packets will be blocked from arriving to the driver layer.
 - Current draws are approximate based and are solely based on TI solution specification: Dynamic mode with Beacon (DTIM = 1 ; TBTT = 100 ms; Beacon duration ~1.6 ms ; Rate=1 Mbps) Beacon in Listen mode This mode reflects results with software drivers and not the RTTT tool.
- **Other WLAN Core Discrete Power Modes:**

Together with **ELP** there are 4 discrete power modes for the WLAN Core. The other three are:

- **Awake mode**
 - In this mode MAC, PHY, and DRPw are fully active and various RT3 functions are all active. While in this mode, power consumption is not optimized.
- **Listen mode**
 - In Listen mode, MAC and Phy are awake, but DRPw shuts down one of the RF channels. While in this mode, the WL1283 SoC will accept only 11b packets; OFDM packets are not supported. This mode saves power while the WL1283 SoC is active and ready to receive a new packet.
- **StandBy (Power Down Mode)**

- In this mode, PHY and DRPw are in shutdown mode. The WL1271 SOC will not be able to receive packets.

6.1.2. BT Power Consumption

Software Low Power Mode - Deep Sleep

Send Vendor specific command to radio during download of patch BT connections will be maintained. No need to download patch. In case of critical suspend need to disable wake on data.

Highest Current Mode

Transferring data using BT Serial port profile. Transmitting EDR data.

*Specification is at 4 dBm and needs to be measured at class1.5 power levels.

Worst Case Suspend Mode

Depends on if either Hardware or Software Low Power Mode is implemented WC numbers here are represented of Software low power mode

State	Comments	VBAT current (mA)			VIO current (mA)		
		Min.	Typ.	Max.	Min.	Typ.	Max.
Supply Voltage VBAT= 3.3V, VIO = 1.8V							
System (MPA3 Guidance)							
Software Low Power Mode - Deep Sleep	See Section		0.2			0.03	
Highest Current Mode	See Section		29			TBD	

Table 17 - BT Power Consumption

6.1.3. GPS Power consumption

GPS sub-section shall not exceed current draw indicted below.

Characteristics		DC Spec	
		Current (mA)	
		Average Typical	Peak
Full Power Tracking Mode	LNA 1.8V	5	7.5
	VIO 1.8V	0.5	0.6
	Vbat 3.3V	22	27
Acquisition Mode @-130dBm Power Level	LNA 1.8V	5	7.5
	VIO 1.8V	0.5	0.6
	Vbat 3.3V	36.5	42
Sleep current	LNA 1.8V	-	-
	VIO 1.8V	0.5	0.6
	Vbat 3.3V	0.1	1.1

Table 18 - GPS Power Consumption

7. Appendix

7.1. Recommended Host PCB Pastemask

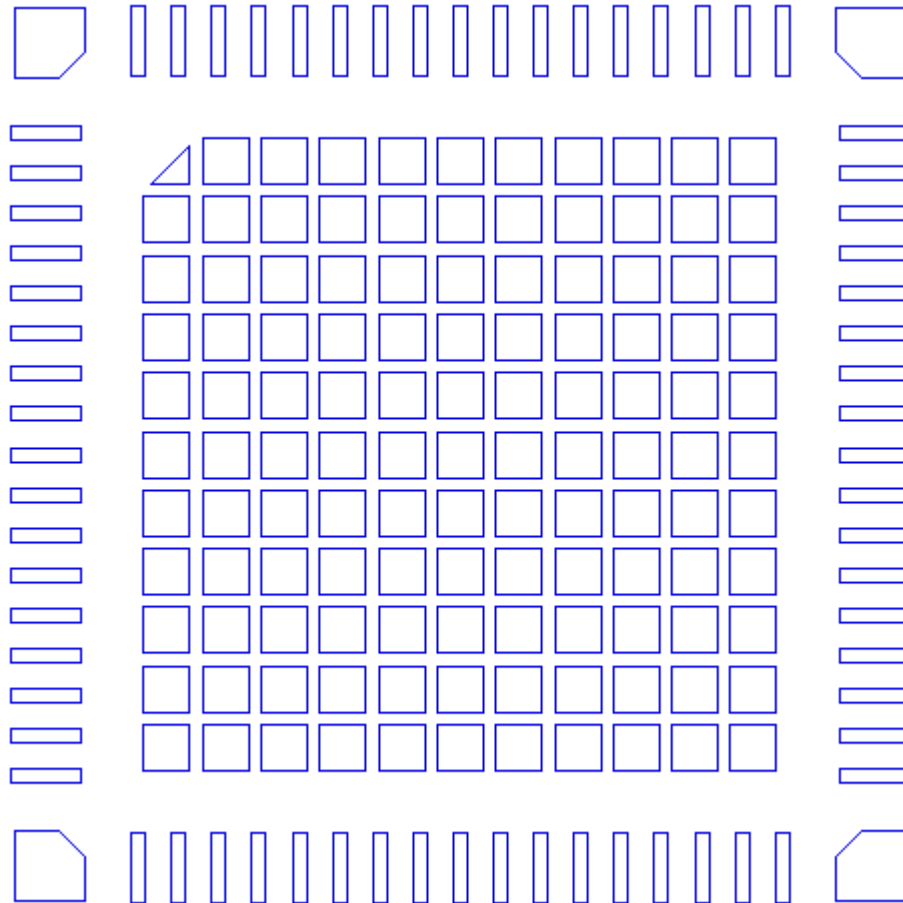
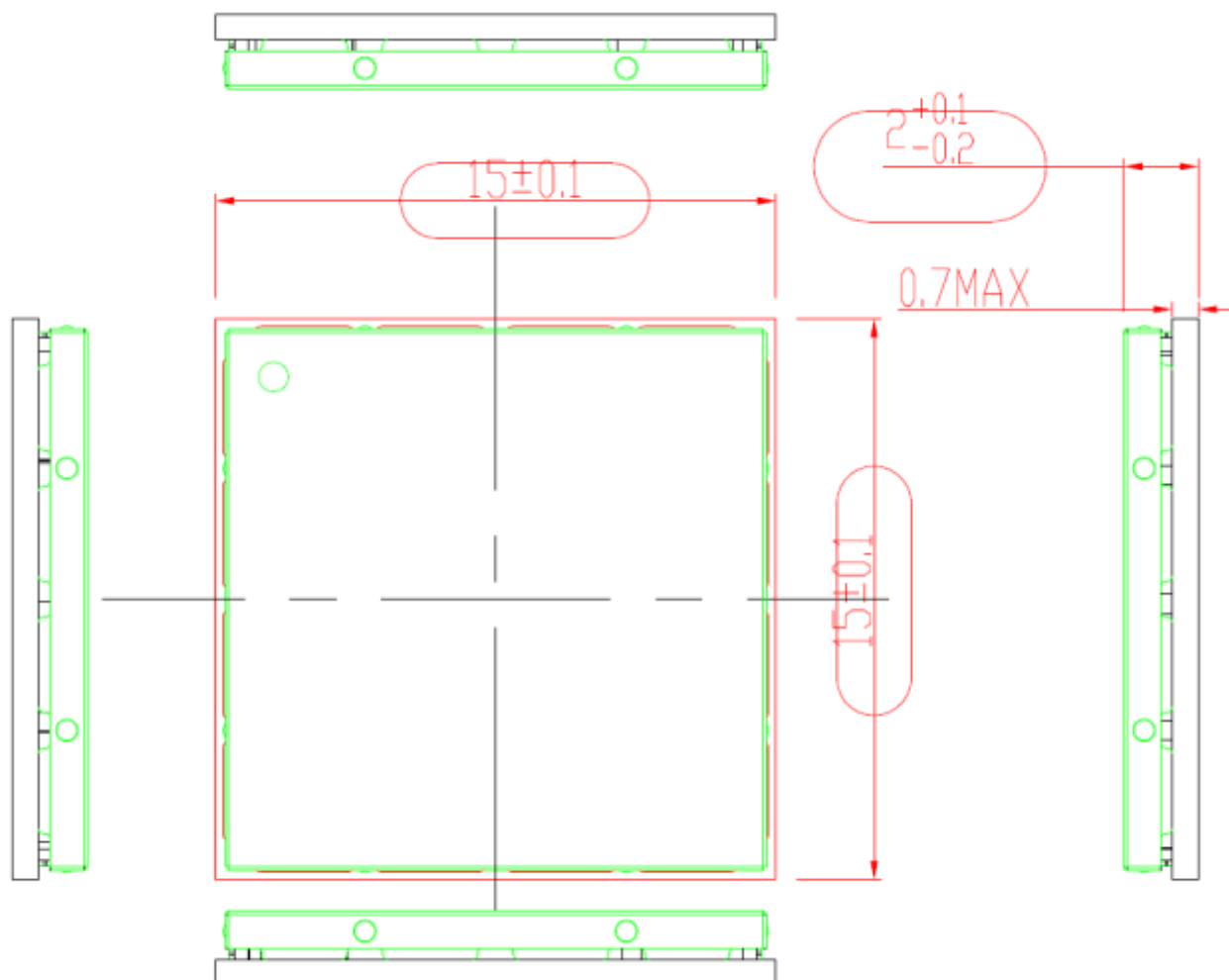

Figure 3 - Recommended host PCB PasteMask

7.2. Mechanical Interface Drawing



7.3. Regulatory

7.3.1. CE Regulations

This equipment may be operated in:							
AT	BE	BG	CH	CY	CZ	DE	DK
EE	ES	FI	FR	GB	GR	HU	IE
IT	IS	LI	LT	LU	LV	MT	NL

148603 **Specification and Integration Guide**

NO	PL	PT	RO	SE	SI	SK	TR
----	----	----	----	----	----	----	----

Products with 2.4–GHz Wireless LAN Devices France

L'utilisation de cet équipement (2.4GHz wireless LAN) est soumise à certaines restrictions: cet équipement peut être utilisé à l'intérieur d'un bâtiment en utilisant toutes les fréquences de 2400 à 2483.5MHz (Chaîne 1–13). Pour une utilisation en environnement extérieur, les fréquences comprises entre 2400-2454 MHz (Chaîne 1-9) peuvent être utilisées. Pour les dernières restrictions, voir <http://www.art-telecom.fr>.

For 2.4–GHz wireless LAN operation of this product, certain restrictions apply. This equipment may use the entire–2400–MHz to 2483.5–MHz frequency band (channels 1 through 13) for indoor applications. For outdoor use, only 2400-2454 MHz frequency band (channels 1-9) may be used. For the latest requirements, see <http://www.art-telecom.fr>.

7.3.2. FCC Regulations

- This mobile phone complies with part 15 of the FCC Rules. Operation is subject to the following two conditions: (1) This device may not cause harmful interference, and (2) this device must accept any interference received, including interference that may cause undesired operation.

- This mobile phone has been tested and found to comply with the limits for a Class B digital device, pursuant to Part 15 of the FCC Rules. These limits are designed to provide reasonable protection against harmful interference in a residential installation. This equipment generates uses and can radiated radio frequency energy and, if not installed and used in accordance with the instructions, may cause harmful interference to radio communications. However, there is no guarantee that interference will not occur in a particular installation. If this equipment does cause harmful interference to radio or television reception, which can be determined by turning the equipment off and on, the user is encouraged to try to correct the interference by one or more of the following measures:

- Reorient or relocate the receiving antenna.
- Increase the separation between the equipment and receiver.
- Connect the equipment into an outlet on a circuit different from that to which the receiver is connected.
- Consult the dealer or an experienced radio/TV technician for help.

FCC Caution:

Any Changes or modifications not expressly approved by the party responsible for compliance could void the user's authority to operate the equipment.

The antenna(s) used for this transmitter must not be co-located or operating in conjunction with any other antenna or transmitter.

Operation on the 5.15-5.25 GHz frequency band is restricted to indoor use only.

Note: The country code selection is for non-US model only and is not available to all US model. Per FCC regulation, all WiFi product marketed in US must fixed to US operation channels only.

Radiation Exposure Statement:

Radiation Exposure Statement:

This equipment complies with FCC radiation exposure limits set forth for an uncontrolled environment. This equipment should be installed and operated with minimum distance 20cm between the radiator & your body.

Note: The country code selection is for non-US model only and is not available to all US model. Per FCC regulation, all WiFi product marketed in US must fixed to US operation channels only.

This device is intended only for OEM integrators under the following conditions:

The antenna must be installed such that 20 cm is maintained between the antenna and users, and

The transmitter module may not be co-located with any other transmitter or antenna.

As long as 2 conditions above are met, further transmitter test will not be required. However, the OEM integrator is still responsible for testing their end-product for any additional compliance requirements required with this module installed

IMPORTANT NOTE: In the event that these conditions can not be met (for example certain laptop configurations or co-location with another transmitter), then the FCC authorization is no longer considered valid and the FCC ID can not be used on the final product. In these circumstances, the OEM integrator will be responsible for re-evaluating the end product (including the transmitter) and obtaining a separate FCC authorization.

End Product Labeling

This transmitter module is authorized only for use in device where the antenna may be installed such that 20 cm may be maintained between the antenna and users. **The final end product must be labeled in a visible area with the following: “Contains FCC ID: XXXXXXXX”, where XXXXXXXX is the approved FCC ID for the device being installed.**

The grantee's FCC ID can be used only when all FCC compliance requirements are met.

Manual Information To the End User

The OEM integrator has to be aware not to provide information to the end user regarding how to install or remove this RF module in the user's manual of the end product which integrates this module.

The end user manual shall include all required regulatory information/warning as show in this manual.

7.3.3. IC Regulations

Industry Canada statement:

This device complies with RSS-210 of the Industry Canada Rules. Operation is subject to the following two conditions: (1) This device may not cause harmful interference, and (2) this device must accept any interference received, including interference that may cause undesired operation.

Ce dispositif est conforme à la norme CNR-210 d'Industrie Canada applicable aux appareils radio exempts de licence. Son fonctionnement est sujet aux deux conditions suivantes: (1) le dispositif ne doit pas produire de brouillage préjudiciable, et (2) ce dispositif doit accepter tout brouillage reçu, y compris un brouillage susceptible de provoquer un fonctionnement indésirable.

Radiation Exposure Statement:

This equipment complies with IC radiation exposure limits set forth for an uncontrolled environment. This equipment should be installed and operated with minimum distance 20cm between the radiator & your body.

Déclaration d'exposition aux radiations:

Cet équipement est conforme aux limites d'exposition aux rayonnements IC établies pour un environnement non contrôlé. Cet équipement doit être installé et utilisé avec un minimum de 20 cm de distance entre la source de rayonnement et votre corps.

This device is intended only for OEM integrators under the following conditions: (For module device use)

- 1) The antenna must be installed such that 20 cm is maintained between the antenna and users, and
- 2) The transmitter module may not be co-located with any other transmitter or antenna.

As long as 2 conditions above are met, further transmitter test will not be required. However, the OEM integrator is still responsible for testing their end-product for any additional compliance requirements required with this module installed.

Cet appareil est conçu uniquement pour les intégrateurs OEM dans les conditions suivantes: (Pour utilisation de dispositif module)

- 1) L'antenne doit être installée de telle sorte qu'une distance de 20 cm est respectée entre l'antenne et les utilisateurs, et
- 2) Le module émetteur peut ne pas être coimplanté avec un autre émetteur ou antenne.

Tant que les 2 conditions ci-dessus sont remplies, des essais supplémentaires sur l'émetteur ne seront pas nécessaires. Toutefois, l'intégrateur OEM est toujours responsable des essais sur son produit final pour toutes exigences de conformité supplémentaires requis pour ce module installé.

IMPORTANT NOTE:

In the event that these conditions can not be met (for example certain laptop configurations or co-location with another transmitter), then the Canada authorization is no longer considered valid and the IC ID can not be used on the final product. In these circumstances, the OEM integrator will be responsible for re-evaluating the end product (including the transmitter) and obtaining a separate Canada authorization.

NOTE IMPORTANTE:

Dans le cas où ces conditions ne peuvent être satisfaites (par exemple pour certaines configurations d'ordinateur portable ou de certaines co-localisation avec un autre émetteur), l'autorisation du Canada n'est plus considéré comme valide et l'ID IC ne peut pas être utilisé sur le produit final. Dans ces circonstances, l'intégrateur OEM sera chargé de réévaluer le produit final (y compris l'émetteur) et l'obtention d'une autorisation distincte au Canada.

End Product Labeling

This transmitter module is authorized only for use in device where the antenna may be installed such that 20 cm may be maintained between the antenna and users. **The final end product must be labeled in a visible area with the following: "Contains IC:XXXXXXXX" , where XXXXXXXX is the approved IC ID for the device being installed.**

Plaque signalétique du produit final

Ce module émetteur est autorisé uniquement pour une utilisation dans un dispositif où l'antenne peut être installée de telle sorte qu'une distance de 20cm peut être maintenue entre l'antenne et les utilisateurs. "Contient des IC: IC: XXXXXXXX", où XXXXXXXX est l'ID approuvée IC pour le périphérique en cours d'installation.

Manual Information To the End User

The OEM integrator has to be aware not to provide information to the end user regarding how to install or remove this RF module in the user's manual of the end product which integrates this module.

The end user manual shall include all required regulatory information/warning as show in this manual.

Manuel d'information à l'utilisateur final

L'intégrateur OEM doit être conscient de ne pas fournir des informations à l'utilisateur final quant à la façon d'installer ou de supprimer ce module RF dans le manuel de l'utilisateur du produit final qui intègre ce module.

Le manuel de l'utilisateur final doit inclure toutes les informations réglementaires requises et avertissements comme indiqué dans ce manuel.

Caution :

- (i) the device for operation in the band 5150-5250 MHz is only for indoor use to reduce the potential for harmful interference to co-channel mobile satellite systems;
- (ii) the maximum antenna gain permitted for devices in the bands 5250-5350 MHz and 5470-5725 MHz shall comply with the e.i.r.p. limit; and
- (iii) the maximum antenna gain permitted for devices in the band 5725-5825 MHz shall comply with the e.i.r.p. limits specified for point-to-point and non point-to-point operation as appropriate.
- (iv) Users should also be advised that high-power radars are allocated as primary users (i.e. priority users) of the bands 5250-5350 MHz and 5650-5850 MHz and that these radars could cause interference and/or damage to LE-LAN devices.

Avertissement:

Le guide d'utilisation des dispositifs pour réseaux locaux doit inclure des instructions précises sur les restrictions susmentionnées, notamment :

- (i) les dispositifs fonctionnant dans la bande 5 150-5 250 MHz sont réservés uniquement pour une utilisation à l'intérieur afin de réduire les risques de brouillage préjudiciable aux systèmes de satellites mobiles utilisant les mêmes canaux;
- (ii) le gain maximal d'antenne permis pour les dispositifs utilisant les bandes 5 250-5 350 MHz et 5 470-5 725 MHz doit se conformer à la limite de p.i.r.e.;
- (iii) le gain maximal d'antenne permis (pour les dispositifs utilisant la bande 5 725-5 825 MHz) doit se conformer à la limite de p.i.r.e. spécifiée pour l'exploitation point à point et non point à point, selon le cas.
- (iv) De plus, les utilisateurs devraient aussi être avisés que les utilisateurs de radars de haute puissance sont désignés utilisateurs principaux (c.-à-d., qu'ils ont la priorité) pour les bandes 5 250-5 350 MHz et 5 650-5 850 MHz et que ces radars pourraient causer du brouillage et/ou des dommages aux dispositifs LAN-EL.