



MN00236A01 Revision Draft 1- December 2015

Zebra and the stylized Zebra head are trademarks of ZIH Corp., registered in many jurisdictions worldwide. All other trademarks are the property of their respective owners.

©2015 ZIH Corp and/or its affiliates. All rights reserved.

Zebra Technologies Corporation  
Lincolnshire, IL U.S.A.  
http://www.zebra.com



This warranty is given by Zebra Technologies Asia Pacific Pte. Ltd., 71 Robinson Road, #05-02/03, Singapore 068895, Singapore. Our goods come with guarantees that cannot be excluded under the Australia Consumer Law. You are entitled to a replacement or refund for a major failure and compensation for any other reasonably foreseeable loss or damage. You are also entitled to have the goods repaired or replaced if the goods fail to be of accepted quality and the failure does not amount to a major failure.

Zebra Technologies Corporation Australia's limited warranty above is in addition to any rights and remedies you may have under the Australian Consumer Law, if you have any queries, please call Zebra Technologies Corporation at +65 6588 0722. You may also visit our website: http://www.zebra.com for the most updated warranty terms.

**For Australia Only:**  
http://www.zebra.com/warranty

For the complete Zebra hardware product warranty statement, go to:

## Warranty

For the latest version of this guide go to: http://www.zebra.com/supprt.

Support at: http://www.zebra.com/supprt.

If you have a problem using the equipment, contact your facility's Technical Systems Support. If there is a problem with the equipment, they will contact Zebra

## Service Information

**Čeština:** Pro zákazníky z EU: Všechny produkty je nutné po skonění jejich životnosti vrátit společnosti Zebra k recyklaci. Informace o způsobu vrácení produktu najdete na webovė stránce: http://www.zebra.com/weee.

**Danski:** Til kunder i EU: Alle produkter skal returneres til Zebra til recirkulering, når de er udjent. Læs oplysningerne om returnering af produkter på: http://www.zebra.com/weee.

**Deutsch:** Für Kunden innerhalb der EU: Alle Produkte müssen am Ende ihrer Lebensdauer zum Recycling an Zebra zurückgesandt werden. Informationen zur Rücksendung von Produkten finden Sie unter http://www.zebra.com/weee.

**Ελληνικά:** Για πελάτες στην E.E.: Όλα τα προϊόντα, στο τέλος της διάρκειας ζωής τους, πρέπει να επιστρέφονται στην Zebra για ανακύκλωση. Για περισσότερες πληροφορίες σχετικά με την επιστροφή ενός προϊόντος, επισκεφθείτε τη διεύθυνση http://www.zebra.com/weee στο Διαδίκτυο.

**Eesti:** EL klientidele: kõik tooted tuleb nende eluea lõppedes tagastada taaskasutamise eesmärgil Zebra'ile. Lisainformatsiooni saamiseks toote tagastamise kohta külastage palun aadressi: http://www.zebra.com/weee.

**English:** For EU Customers: All products at the end of their life must be returned to Zebra for recycling. For information on how to return product, please go to: http://www.zebra.com/weee.

**Español:** Para clientes en la Unión Europea: todos los productos deberán entregarse a Zebra al final de su ciclo de vida para que sean reciclados. Si desea más información sobre cómo devolver un producto, visite: http://www.zebra.com/weee.

**Français:** Clients de l'Union Européenne : Tous les produits en fin de cycle de vie doivent être retournés à Zebra pour recyclage. Pour de plus amples informations sur le retour de produits, consultez : http://www.zebra.com/weee.

**Italiano:** per i clienti dell'UE: tutti i prodotti che sono giunti al termine del rispettivo ciclo di vita devono essere restituiti a Zebra al fine di consentirne il riciclaggio. Per informazioni sulle modalità di restituzione, visitare il seguente sito Web: http://www.zebra.com/weee.

**Latviešu:** ES klientiem: visi produkti pēc to kalpošanas mūža beigām ir jānogādā atpakaļ Zebra atreizējai pārstrādei. Lai iegūtu informāciju par produktu nogādāšanu Zebra, lūdz, skatiet: http://www.zebra.com/weee.

**Lietuvių:** ES vartotojams: visi gaminiai, pasibaigus jų eksploatacijos laikui, turi būti gražinti utilizuoti į kompaniją „Zebra“. Daugiau informacijos, kaip gražinti gaminių, rasite: http://www.zebra.com/weee.

**Magyar:** Az EU-ban vásárlóknak: Minden tökéretem termékét a Zebra vállalathoz kell eljuttatni újrahazszonítás céljából. A termék visszajuttatásának módjával kapcsolatos tudnivalókrét látogasson el a http://www.zebra.com/weee weboldalra.

**Malti:** Għal klijenti fl-UE: Il-prodotti kollha li jkunu waslu fl-aħħar tal-hajja ta' l-użu tagħhom, iridu jiġu rritornati għand Zebra għar-riċiklaġġ. Għal aktar taġrif dwar kif għandek tirritorna l-prodott, jekk jogħġbok zur: http://www.zebra.com/weee.

**Nederlands:** Voor klanten in de EU: alle producten dienen aan het einde van hun levensduur naar Zebra te worden teruggezonden voor recycling. Raadpleeg http://www.zebra.com/weee voor meer informatie over het terugzenden van producten.

**Polski:** Klienci z obszaru Unii Europejskiej: Produkty wycofane z eksploatacji naleŹy zwrócić do firmy Zebra w celu ich użycizacji. Informacje na temat zwrotu produktów znajdujŹ się na stronie internetowej http://www.zebra.com/weee.

**Portugués:** Para clientes da UE: todos os produtos no fim de vida devem ser devolvidos à Zebra para reciclagem. Para obter informações sobre como devolver o produto, visite: http://www.zebra.com/weee.

**Românski:** Pentru clienții din UE: Toate produsele, la sfârșitul duratei lor de funcționare, trebuie returnate la Zebra pentru reciclare. Pentru informații despre returnarea produsului, accesați: http://www.zebra.com/weee.

**Slovenski:** Za kupce v EU: vsi izdelki se morajo po poteku življenjske dobe vrniti podjetju Zebra za reciklažo. Za informacije o vračilu izdelka obiščite: http://www.zebra.com/weee.

**Slovenčina:** Pre zákazníkov z krajín EU: Všetky výrobky musia byť po uplynutí doby ich životnosti vrátené spoločnosti Zebra na recykláciu. Blížšie informácie o vrátení výrobkov nájdete na: http://www.zebra.com/weee.

**Suomi:** Asiakkat Euroopan unionin alueella: Kaikki tuotteet on palautettava kierrätettäväksi Zebra-yhtiöön, kun tuotetta ei enää käytetä. Lisätietoja tuotteen palauttamisesta on osoitteessa http://www.zebra.com/weee.

**Svenska:** För kunder inom EU. Alla produkter som uppnått sin livslängd måste returneras till Zebra för återvinning. Information om hur du returnerar produkten finns på http://www.zebra.com/weee.

**Türkçe:** AB Müşterileri için: Kullanım süresi dolan tüm ürünler geri dönüştürme için Zebra'ya iade edilmelidir. Ürünlerin nasıl iade edileceği hakkında bilgi için lütfen şu adresi ziyaret edin: http://www.zebra.com/weee.

**TURKISH WEEE Statement of Compliance**

EEE Yönetmeliğine Uyğundur



## Industrial Scanner Cradle

## Quick Reference Guide

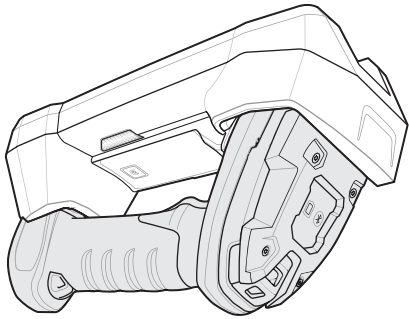

## FLB3678 CRADLE



© 2015 Symbol Technologies, Inc.

Zebra reserves the right to make changes to any software or product to improve reliability, function, or design.

Zebra does not assume any product liability arising out of, or in connection with, the application or use of any product, circuit, or application described herein.

No license is granted, either expressly or by implication, estoppel, or otherwise under any Zebra Technologies Corporation intellectual property rights. An implied license exists only for equipment, circuits, and subsystems contained in Zebra products.

Zebra and the stylized Zebra head are trademarks of ZIH Corp., registered in many jurisdictions worldwide. All other trademarks are the property of their respective owners.

Zebra Technologies Corporation  
Lincolnshire, IL USA  
http://www.zebra.com

## Health and Safety RecommendationsErgonomic

**Caution:** In order to avoid or minimize the potential risk of ergonomic injury follow the recommendations below. Consult with your local Health & Safety Manager to ensure that you are adhering to your company's safety programs to prevent employee injury.

- Reduce or eliminate repetitive motion
- Maintain a natural position
- Reduce or eliminate excessive force
- Keep objects that are used frequently within easy reach

- Perform tasks at correct heights
- Reduce or eliminate vibration
- Reduce or eliminate direct pressure
- Provide adjustable workstations
- Provide adequate clearance
- Improve work procedures.

RF signals may affect improperly shielded or inadequately shielded electronic systems in motor vehicles (including safety systems). Check with the manufacturer or its representative regarding your vehicle. You should also consult the manufacturer about any equipment that has been added to your vehicle.

### Vehicle Installation

Use ONLY a Zebra approved UL LISTED ITE (IEC/CEN 60950-1, LP/S/SELV) power supply with electrical ratings: Output 12Vdc, min 4, 16A, with a maximum ambient temperature of at least 50 degrees C. Use of alternative power supply will invalidate any approvals given to this unit and may be dangerous.

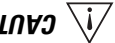

**CAUTION** Operation of the device without regulatory approval is illegal.

Slovenia, Spain, Sweden, Switzerland and the United Kingdom.

Note: Europe includes: Austria, Belgium, Bulgaria, Croatia, Czech Republic, Cyprus, Denmark, Estonia, Finland, France, Germany, Greece, Hungary, Iceland, Ireland, Italy, Latvia, Liechtenstein, Lithuania, Luxembourg, Malta, Netherlands, Norway, Poland, Portugal, Romania, Slovak Republic.

is available at: http://www.zebra.com/doc.

Please refer to the Declaration of Conformity (DoC) for details of other country markings. This Korea, Australia, and Europe.

Regulatory markings, subject to certification, are applied to the device signifying the radio(s) is/are approved for use in the following countries: United States, Canada, Japan, China, South

### Wireless Device Country Approvals

please visit https://www.bluetooth.org/pf/pg/lists/cfm.

This is an approved Bluetooth product. For more information or to view End Product Listing,

### Bluetooth® Wireless Technology

Zebra hereby declares that this device is in compliance with the essential requirements and other relevant provisions of Directive 1995/5/EC and 2011/65/EU. A Declaration of Conformity may be obtained from http://www.zebra.com/doc.

### Statement of Compliance

Declared maximum operating temperature: 50°C.

Do NOT attempt to charge damp/wet batteries. All components must be dry before connecting to an external power source.

Only use Zebra approved and UL Listed accessories, battery packs and battery chargers.



**CAUTION**

The user's authority to operate the equipment. Any changes or modifications to Zebra equipment not expressly approved by Zebra could void Local language translations are available at the following website: http://www.zebra.com/doc.

They are sold and will be labeled as required.

All Zebra devices are designed to be compliant with the rules and regulations in the locations

This guide applies to the following Model Number: FLB3678

This device is approved under Zebra Technologies Corporation.

### Regulatory Information

## RF Exposure Guidelines

### Reducing RF Exposure – Use Properly

Only operate the device in accordance with the instructions supplied. The device complies with internationally recognized standards covering human exposure to electromagnetic fields from radio devices. For information on "International" human exposure to electromagnetic fields refer to the Zebra Declaration of Conformity (DoC) at http://www.zebra.com/doc.

For further information on the safety of RF energy from wireless devices, see http://responsibility.zebra.com/index.php/downloads/, which is located under Wireless Communications and Health.

### Europe

Remote and Standalone Antenna Configurations - To comply with EU RF exposure requirements, antennas that are mounted externally at remote locations or operating near users at stand-alone desktop of similar configurations must operate with a minimum separation distance of 20 cm from all persons.

### US and Canada

To comply with FCC RF exposure compliance requirement, the antenna used for this transmitter must not be co-located or operating in conjunction with any other transmitter/antenna except those already approved in this filing.

Radiation Exposure Statement:

This equipment complies with IC radiation exposure limits set forth for an uncontrolled environment. This equipment should be installed and operated with minimum distance 20cm between the radiator and your body.

NOTE IMPORTANTE: (Pour l'utilisation de dispositifs mobiles)

Déclaration d'exposition aux radiations:

Cet équipement est conforme aux limites d'exposition aux rayonnements IC établies pour un environnement non contrôlé. Cet équipement doit être installé et utilisé avec un minimum de 20 cm de distance entre la source de rayonnement et votre corps.

Remote and Standalone Antenna Configurations

To comply with FCC RF exposure requirements, antennas that are mounted externally at remote locations or operating near users at stand-alone desktop of similar configurations must operate with a minimum separation distance of 20 cm from all persons.

### Radio Frequency Interference Requirements-FCC

**Note:** This equipment has been tested and found to comply with the limits for a Class B digital device, pursuant to Part 15 of the FCC rules. These limits are designed to provide reasonable protection against harmful interference in a residential installation. This equipment generates, uses and can radiate radio frequency energy and, if not installed and used in accordance with the instructions, may cause harmful interference to radio communications. However

there is no guarantee that interference will not occur in a particular installation. If this equipment does cause harmful interference to radio or television reception, which can be determined by turning the equipment off and on, the user is encouraged to try to correct the interference by one or more of the following measures:

- Reorient or relocate the receiving antenna
- Increase the separation between the equipment and receiver
- Connect the equipment in an outlet on a circuit different from the receiver is connection
- Consult the dealer or an experienced radio/TV technician for help

### Radio Transmitters (Part 15)

This device complies with Part 15 of the FCC Rules. Operation is subject to the following two conditions: (1) This device may not cause harmful interference, and (2) this device must accept any interference received, including interference that may cause undesired operation.

### Radio Frequency Interference Requirements-Canada

CAN ICES-3 (B)/NMB-3(B)

Radio Transmitters - This device complies with Industry Canada's license-exempt RSS's. Operation is subject to the following two conditions: (1) This device may not cause interference; and (2) This device must accept any interference, including interference that may cause undesired operation of the device.

Cet appareil est conforme exemptés de licence le flux RSS de Industrie Canada. Son fonctionnement est soumis aux deux conditions suivantes:

(1) Ce dispositif ne peut causer des interférences; et (2) Cet appareil doit accepter toute interférence, y compris les interférences qui peuvent causer un mauvais fonctionnement de l'appareil.

### Radio Frequency Interference Requirements-Brazil

For more information consult the website www.anatel.gov.br

Declarações Regulamentares para STB/FLB3678 - Brazil

Nota: A marca de certificação se aplica ao Transceptor, modelo STB/FLB3678. Este equipamento opera em caráter secundário, isto é, não tem direito a proteção contra interferência prejudicial, mesmo de estações do mesmo tipo, e não pode causar interferência a sistemas operando em caráter primário. Para maiores informações sobre ANATEL consulte o site: www.anatel.gov.br Este equipamento opera em caráter secundário, isto é, não tem direito a proteção contra interferência prejudicial, mesmo de estações do mesmo tipo, e não pode causar interferência a sistemas operando em caráter primário.

Este produto está homologado pela Anatel, de acordo com os procedimentos regulamentados pela Resolução n°242/2000 e atende aos requisitos técnicos aplicados, incluindo os limites de exposição da Taxa de Absorção Específica referente a campos elétricos, magnéticos e eletromagnéticos de radiofrequência, de acordo com as Resoluções n° 303/2002 e 533/2009.

Este dispositivo está em conformidade com as diretrizes de exposição à radiofrequência quando posicionado pelo menos 20 centímetros de distância do corpo. Para maiores informações, consulte o site da Anatel.

### Chile

Este equipo cumple con la Resolución No 403 de 2008, de la Subsecretaría de telecomunicaciones, relativa a radiaciones electromagnéticas.

### Ukraine

Дане обладнання відповідає вимогам технічного регламенту №1057, № 2008 на обмеження щодо використання деяких небезпечних речовин в електричних та електронних пристроях.

### Japan (VCCI) - Voluntary Control Council for Interference

Class B ITE

この装置は、クラスB情報技術装置です。この装置は、家庭環境で使用することを目的としていますが、この装置がラジオやテレビジョン受信機に近接して使用されると、受信障害を引き起こすことがあります。

取扱説明書に従って正しい取り扱いをして下さい。 VCCI-B

### Taiwan

#### 臺灣

低功率電波輻射性電機管理辦法 第十二條

經型式認證合格之低功率射頻電機，非經許可，公司、商號或使用者均不得擅自變更頻率、加大功率或變更原設計之特性及功能。

第十四條

低功率射頻電機之使用不得影響飛航安全及干擾合法通信；經發現有干擾現象時，應立即停用，並改善至無干擾時方得繼續使用。

前項合法通信，指依電信規定作業之無線電通信。

低功率射頻電機須符合合法通信或工業、科學及醫療用電波輻射性電機設備之干擾。

「本器材須經專業工程人員安裝及設定，始得設置使用，且不得直接販售給一般消費者」警語。

# Draft 1\_Reg Submission



## Introduction

The FLB3678 cordless scanner cradle acts as charger and radio communication interface for the XX3678 cordless scanner. It attaches to a mounting bracket using three isolators. The bracket is then mounted on the forklift surface.

The FLB3678 cradle receives data from the scanner via a Bluetooth radio, and sends that data to the host through an attached cable. The cradle also charges the scanner's internal battery pack when the scanner is inserted. A portable power supply on the forklift supplies power to the cradle.

This document provides basic instructions on setting up and using the cradle. Any discussion of transmission of information refers specifically to the FLB3678 cradle.

**CAUTION** LS3578 and DS3578 cordless scanners are incompatible with FLB3678 cradles.

## Equipment Supplied

The cradle package includes:

- Cradle
- Mounting bracket with isolators
- Three 8-32 x 1.5" Phillips head screws (for attaching cradle to mounting bracket).

## Accessories

The following equipment may be needed:

- Three 1/4-20 screws, minimum length 1.0" (for fastening bracket to mounting surface).

Save the shipping container for storing or shipping. Inspect all equipment for damage. If anything is damaged or missing, call an authorized Zebra Support Center immediately.

## Related Documentation

LI3678 Product Reference Guide, p/n MN001740Axx.

LI3678 Quick Start Guide, p/n MN002323Axx.

STB3678 Quick Reference Guide, p/n MN002334Axx.

This documentation is available at: [www.zebra.com/support](http://www.zebra.com/support).

## Cradle Parts

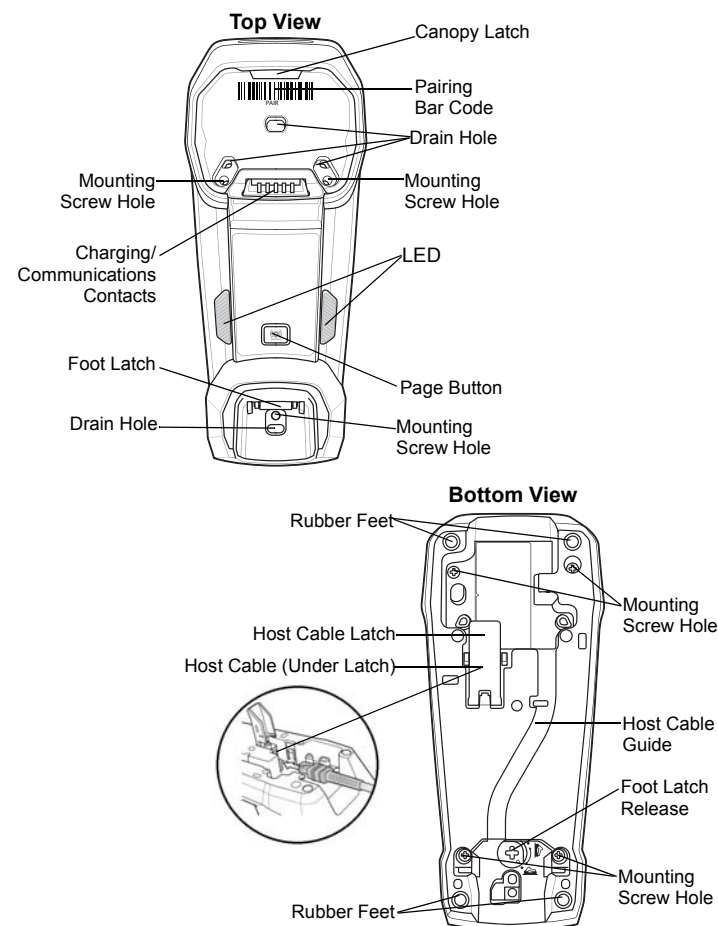

## Cradle Connections

**IMPORTANT** Connect the interface cable and power supply (if necessary) in the following order to ensure proper operation of the scanner and cradle.

1. Connect the appropriate cable to the power supply and an AC power source, if necessary. This will ensure detection of the host and prevent inadvertently back powering the cradle from improper detection of the host.
2. Insert the interface cable into the host port.
3. Lift the latch and connect the interface cable into the cradle's host port, then close the latch.
4. If applicable, thread the host cable over the cable hook and run the host and power cables into their respective cable grooves, or use cable ties to secure them to the mounting plate after it is attached to the cradle (see [Mounting the Cradle](#)).
5. Pair the scanner to the cradle either by inserting it in the cradle (if Pair on Contacts is enabled) or by scanning the pairing bar code.
6. If necessary, scan the appropriate host bar code (for non-autodetected interfaces). Refer to the *Product Reference Guide*.

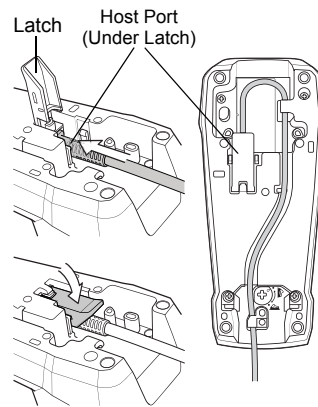

## Changing the Host Interface

To connect to a different host, or to the same host through a different cable:

1. Unplug the interface cable from the host.
2. Unplug the power supply from the cradle.
3. Connect the interface cable to the new host, or the new interface cable to the existing host.
4. Reconnect the power supply, if required.
5. If necessary, scan the appropriate host bar code (for non-autodetected interfaces). Refer to the *Product Reference Guide*.

## Using a Host Interface to Supply Power

Some hosts can provide power to the cradle via the host interface, instead of an external power supply.

**CAUTION** Always disconnect the DC power supply BEFORE disconnecting the cable to the host end or the cradle may not recognize the new host.

## Mounting the Cradle

### Horizontal Mount

1. Ensure the desk/wall mount converter knob is in the correct position, shown at right.
2. If mounting the cradle horizontally where no fastening is necessary, peel the protective paper from the back of the rubber feet included with the cradle packaging, and attach the feet to the cradle at the indentations in the plastic. These feet provide traction and prevent surface damage.

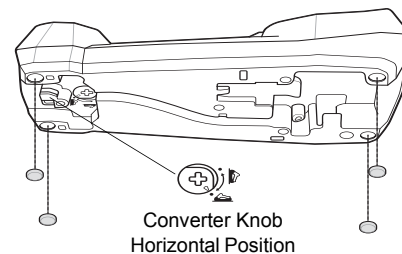

### Vertical Mount

**NOTE** Do not use the rubber feet when mounting in a vertical orientation.

### To mount the cradle on a vertical surface:

1. Use a Philips screwdriver to turn the desk/wall mount converter knob to the position shown below. The front latches protract to engage the depressions at the base of the scanner's handle.
2. Attach the interface and power cables (see [Cradle Connections](#)).
3. Press the cables into the cable grooves.
4. Position the cradle on the mounting surface, or use the template included in this guide.
5. Mark the surface through the three holes on the bottom of the cradle, or use the mounting template to determine the location of the screw holes.
6. Pre-drill holes to accommodate three 1.5" #8 Phillips head screws.
7. Attach the cradle securely to the surface.
8. Place the scanner in the cradle.

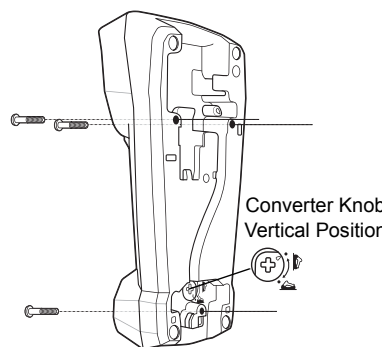

## Inserting the Scanner in the Cradle

**CAUTION** Do not pour, spray, or spill any liquid on the cradle.

To insert the scanner in the cradle:

- Insert the scanner top first. Push the handle until it clicks into place, engaging the contacts in the cradle and scanner.

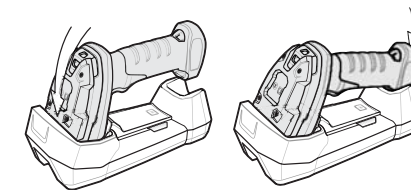

## Sending Data to the Host Computer

The cradle receives data from the scanner via a wireless radio connection and transmits it to the host computer via the host cable. The scanner and cradle must be paired for successful wireless communication.

### Pairing

**NOTE** The pairing bar code that connects the scanner to a cradle is unique to each cradle. Do not scan data or parameters until pairing completes.

Pairing registers a scanner to the cradle such that the scanner and cradle can exchange information. The FLB3678 operates in two modes: Point-to-Point and Multipoint-to-Point. In Point-to-Point mode, pair the linear imager scanner to the cradle either by inserting it in the cradle (if pair on contacts is enabled), or by scanning the pairing bar code. In Multipoint-to-Point mode, you can pair up to seven scanners to one cradle.

To pair the linear imager scanner with the cradle, scan a pairing bar code. A high-low-high-low beep sequence followed by a low-high beep sequence indicates successful pairing and connection to the remote device. A long low, long high beep sequence indicates unsuccessful pairing.

### Lost Connection to Host

If scanned data does not transmit to the cradle's host, ensure that all cables are firmly inserted and the power supply is connected to an appropriate AC outlet, if applicable. If scanned data still does not transmit to the host, reestablish a connection with the host:

1. Disconnect the power supply from the cradle.
2. Disconnect the host interface cable from the cradle.
3. Wait three seconds.
4. Reconnect the host interface cable to the cradle.
5. Reconnect the power supply to the cradle, if required.
6. Reestablish pairing with the cradle by scanning the pairing bar code.

## Charging the Scanner Battery in the Cradle

When using a new battery in the scanner, the battery requires a charge to be enabled. Insert the battery in the scanner and place the scanner in the FLB3678 cradle (see [Inserting the Scanner in the Cradle](#)). The battery begins charging when the scanner LED indicator starts flashing amber. The battery is fully charged when the cradle LED is solid green. A complete charge of a fully discharged battery can take up to three hours using external power and up to ten hours using the USB interface cable.

## Cradle LED Indicators

LED	Indication
Green	Power on
Green flashing	Bluetooth connection established
Blue	Page button
Amber (fast fast slow)	Scanner page issued

### Battery Indications

Amber Blinking	Charging
Amber fast blinking	Charging error
Green	Fully charged

## Troubleshooting

If the cradle does not work after following the previous procedures:

- Check the system power.
- Check for loose cable connections.
- Check that the scanner is inserted properly in the cradle.
- Check that the host settings are correct and the cradle is connected to the appropriate port on the host.

## Wall Mount Template

