

AP-7131 Access Point

Installation Guide

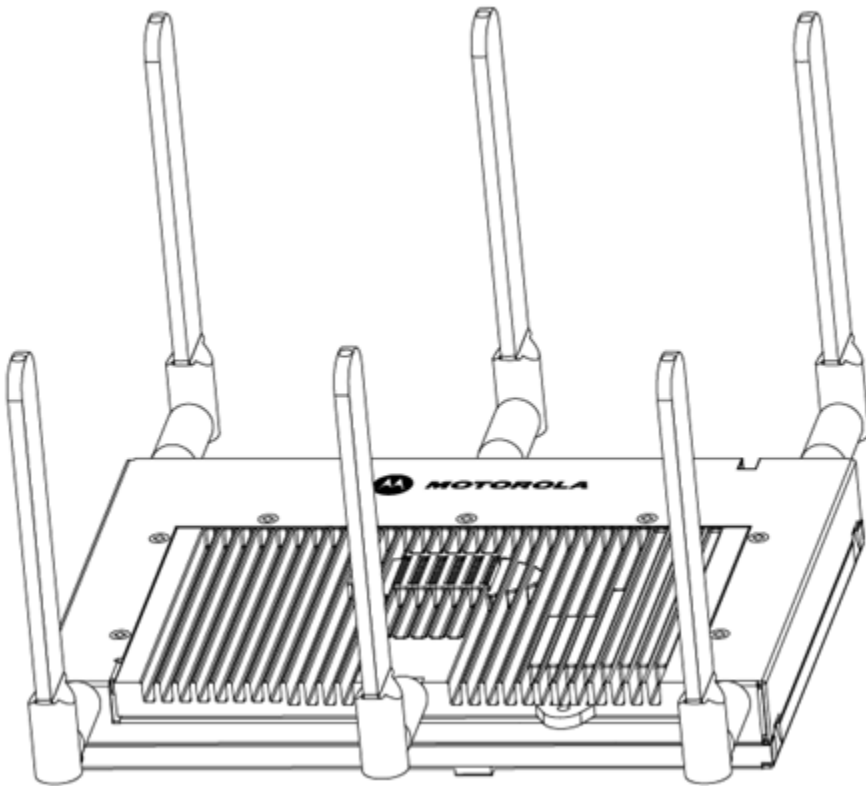

| | |
|---|-----------|
| 1.0 Introduction | 1 |
| 1.1 Document Conventions | 1 |
| 1.2 Warnings | 2 |
| 1.3 Site Preparation | 2 |
| 2.0 Hardware Installation | 3 |
| 2.1 Precautions | 3 |
| 2.2 Package Contents | 3 |
| 2.3 AP-7131 Placement | 4 |
| 2.4 Mounting the AP-7131 | 9 |
| 2.5 LED Indicators | 19 |
| 3.0 Basic AP-7131 Configuration | 21 |
| 3.1 Resetting the AP-7131 Password | 23 |
| 3.2 Configuring "Basic" Device Settings | 24 |
| 3.3 Where to Go From Here? | 32 |

4.0 Regulatory Compliance 33
5.0 Waste Electrical and Electronic Equipment (WEEE) 38
6.0 Motorola’s Enterprise Mobility Support Center 40

MOTOROLA and the Stylized M Logo are registered in the US Patent & Trademark Office. Symbol is a registered trademark of Symbol Technologies, Inc. All other product or service names are the property of their respective owners. © Motorola, Inc. 2008. All rights reserved.

1 Introduction

As a standalone access point, the AP-7131 provides small and medium-sized businesses with a consolidated wired and wireless networking infrastructure, all in a single device. The integrated router, gateway, firewall, DHCP and AAA Radius servers, VPN, hot-spot gateway and *Power-over-Ethernet* (PoE) simplify and reduce the costs associated with networking by eliminating the need to purchase and manage multiple pieces of equipment.

The AP-7131 is also designed to meet the needs of large, distributed enterprises by converging the functionality of a thick access point and thin access port into a single device. This mode enables the deployment of a fully featured intelligent access point that can be centrally configured and managed via a Motorola wireless switch in either corporate headquarters or a *network operations center* (NOC). In the event the connection between the AP-7131 and the wireless switch is lost, a *Remote Site Survivability* (RSS) feature ensures the delivery of uninterrupted wireless services at the local or remote site. All traffic between the adaptive access points and the wireless switch is secured through an IPsec tunnel. Additionally, compatibility with Motorola's RF Management Suite allows you to centrally plan, deploy, monitor, and secure large AP-7131 deployments.

If new to the AP-7131 and access point technology, refer to the *AP-7131 Product Reference Guide* to familiarize yourself with access point technology and the feature set exclusive to the Motorola AP-7131. The guide is available, at <http://support.symbol.com/support/product/manuals.do>.

1.1 Document Conventions

The following graphical alerts are used in this document to indicate notable situations:



NOTE Tips, hints, or special requirements that you should take note of.



CAUTION Care is required. Disregarding a caution can result in data loss or equipment malfunction.



WARNING! Indicates a condition or procedure that could result in personal injury or equipment damage.

1.2 Warnings

- Read all installation instructions and site survey reports, and verify correct equipment installation before connecting the AP-7131 to its power source.
- Remove jewelry and watches before installing this equipment.
- Verify that the unit is grounded before connecting it to the power source.
- Verify that any device connected to this unit is properly wired and grounded.
- Connect all power cords to a properly wired and grounded electrical circuit.
- Verify that the electrical circuits have appropriate overload protection.
- Attach only approved power cords to the device.
- Verify that the power connector and socket are accessible at all times during the operation of the equipment.
- Do not work with power circuits in dimly lit spaces.
- Do not install this equipment or work with its power circuits during thunderstorms or other weather conditions that could cause a power surge.
- Verify there is adequate ventilation around the device, and that ambient temperatures meet equipment operation specifications.

1.3 Site Preparation

- Consult your site survey and network analysis reports to determine specific equipment placement, power drops, and so on.
- Assign installation responsibility to the appropriate personnel.
- Identify and document where all installed components are located.
- Provide a sufficient number of power drops for your equipment.
- Ensure adequate, dust-free ventilation to all installed equipment.
- Identify and prepare Ethernet and console port connections.
- Verify that cable lengths are within the maximum allowable distances for optimal signal transmission.

2 Hardware Installation

An AP-7131 installation includes mounting the AP-7131 on a wall, ceiling T-bar or an above the ceiling orientation, connecting the AP-7131 to the network (LAN or WAN port connection), connecting antennas and applying power. Installation procedures vary for different environments.

An AP-7131 model access point has the following port designations:

- GE1/POE - LAN port
- GE2 - WAN Port

2.1 Precautions

Before installing the AP-7131 verify the following:

- Do not install in wet or dusty areas without additional protection. Contact a Motorola representative for more information.
- Verify the environment has a continuous temperature range between -20° C to 50° C.

2.2 Package Contents

Check package contents for the correct model AP-7131 and applicable AP-7131 accessories. Each available configuration (at a minimum), contains:

- AP-7131 model access point (accessories dependent on SKU ordered)
- AP-7131 Install Guide (this guide)
- Accessories Bag (4 rubber feet and a LED light pipe and badge with label for above the ceiling installations)

Contact the Motorola Support Center to report missing or improperly functioning items.



NOTE The AP-7131 ships with a cover (facade) to protect the access point. The cover disconnects from the access point as illustrated on the next page. When attached, the AP-7131's LEDs continue to illuminate through the cover.

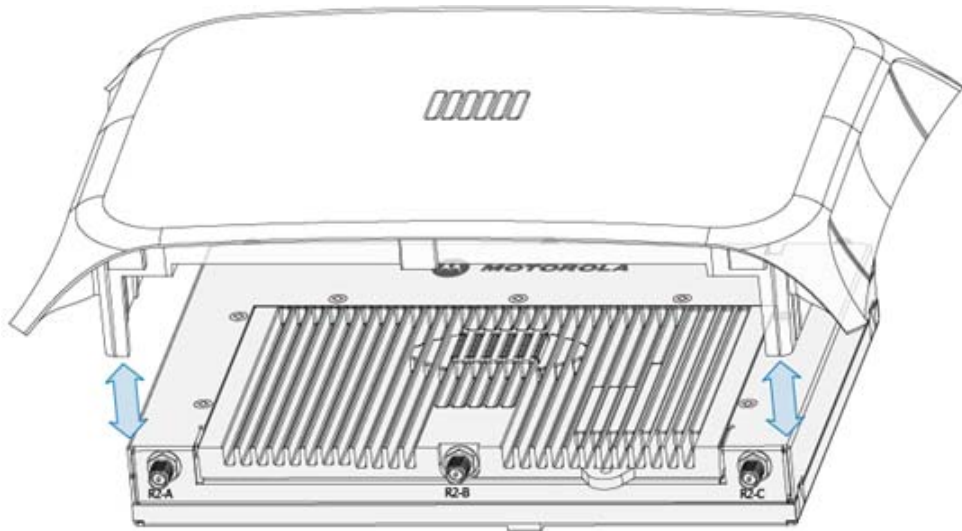

2.3 AP-7131 Placement

For optimal performance, install the AP-7131 away from transformers, heavy-duty motors, fluorescent lights, microwave ovens, refrigerators and other industrial equipment. Signal loss can occur when metal, concrete, walls or floors block transmission. Install the AP-7131 in open areas or add access points as needed to improve coverage.

Place the AP-7131 using the following guidelines:

- Install the AP-7131 at an ideal height of 10 feet from the ground.
- Orient the AP-7131 antenna vertically for best reception.
- Point the AP-7131 antenna(s) downward if attaching to the ceiling.

Motorola recommends conducting a site survey to define and document radio interference obstacles before installing the AP-7131 to maximize its radio coverage area.

2.3.1 AP-7131 Antenna Options

Motorola supports two antenna suites for the AP-7131. One antenna suite supporting the 2.4 GHz band and another antenna suite supporting the 5.2 GHz band. Select an antenna model best suited to the intended operational environment of your AP-7131.



NOTE On a single-radio AP-7131, Radio 1 can be configured to be either a 2.4 GHz or 5.2 GHz radio. On a dual-radio model, Radio 1 refers to the AP-7131's 2.4 GHz radio and Radio 2 refers to the AP-7131 5.2 GHz radio. However, there could be some cases where a dual-radio AP-7131 is performing a Rogue AP detector function. In this scenario, the AP-7131 is receiving in either 2.4 GHz or 5.2 GHz over the Radio 1 or Radio 2 antennas depending on which radio is selected for the scan.

Antenna connectors for Radio 1 are located in a different location from the Radio 2 antenna connectors. On single radio versions, the R-SMA connectors can support both bands and should be connected to a R-SMA dual-band antenna or an appropriate single band antenna. If necessary a R-SMA to R-BNC adapter (Part No. 25-72178-01) can be purchased separately from Motorola.

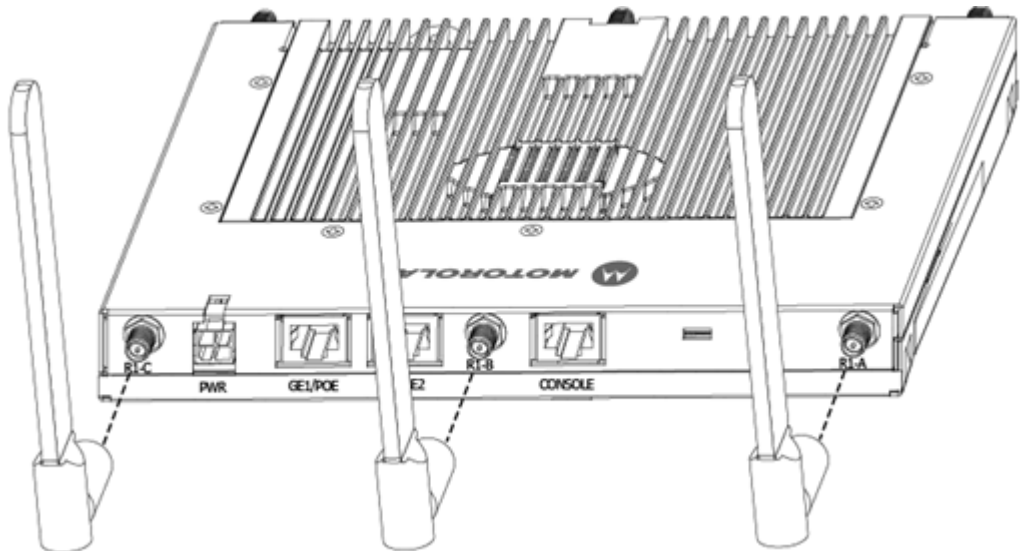

Certain Rogue AP Detection and Intrusion Detection features use an AP-7131 radio to perform dual-band scanning. The dedicated radio should be connected to an appropriate dual-band dipole antenna (Part No. ML-2452-APA2-01).

The 2.4 GHz antenna suite includes the following models:

| Part Number | Antenna Type | Nominal Net Gain (dBi) |
|--------------------|--------------------------------------|-------------------------------|
| ML-2499-11PNA2-01R | Wide Angle Directional | 8.5 |
| ML-2499-HPA3-01R | Omni-Directional Antenna | 3.3 |
| ML-2499-BYGA2-01R | Yagi Antenna | 13.9 |
| ML-2452-APA2-01 | Dual-Band | 3.0 |
| ML-2452-PTA2M3X3-1 | Facade with 6 Element Antenna Module | 2.0 |
| ML-2452-PTA3M3-036 | 3 Port MIMO Antenna | 3.0 |



NOTE An additional adapter is required to use ML-2499-11PNA2-01R and ML-2499-BYGA2-01R model antennas. Please contact Motorola for more information.

The 5.2 GHz antenna suite includes the following models:

| Part Number | Antenna Type | Nominal Net Gain (dBi) |
|--------------------|--------------------------------------|-------------------------------|
| ML-5299-WPNA1-01R | Panel Antenna | 13.0 |
| ML-5299-HPA1-01R | Wide-Band Omni-Directional Antenna | 5.0 |
| ML-2452-APA2-01 | Dual-Band | 4.0 |
| ML-2452-PTA2M3X3-1 | Facade with 6 Element Antenna Module | 2.0 |
| ML-2452-PTA3M3-036 | 3 Port MIMO Antenna | 3.0 |

For detailed specifications on the antennas available to the AP-7131, refer to the *AP-7131 Product Reference Guide* or the *Enterprise Wireless LAN Antenna Specification Guide*. Both guides are available at <http://support.symbol.com/support/product/manuals.do>.

2.3.2 Power Injector System

An AP-7131 receives power directly from a 48V AC-DC power supply (Part No. 50-14000-247R) or via an Ethernet cable connected to the GE1/POE port.

When users purchase a Motorola WLAN solution, they often need to place access points in obscure locations. In the past, a dedicated power source was required for each access point in addition to the Ethernet infrastructure. This often required an electrical contractor to install power drops at each access point location. An approved power injector solution merges power and Ethernet into one cable, reducing the burden of installation and allows optimal AP-7131 placement in respect to the intended radio coverage area.

The Power Injector is included in certain AP-7131 product SKUs. The Power Injector (Part No. AP-PSBIAS-1P3-AFR) is a high power POE Injector delivering up to 30 watts.

The Motorola AP-7131 Power Supply (Part No. 50-14000-247R) is not included with the AP-7131 and is orderable separately as an accessory.



CAUTION The AP-7131 supports any standards-based 802.3af high power complaint power source. However, using the wrong solution (including a POE system used on a legacy Motorola access point) could severely damage the AP-7131 and void the product warranty.

A separate Power Injector is required for each AP-7131 comprising the network.

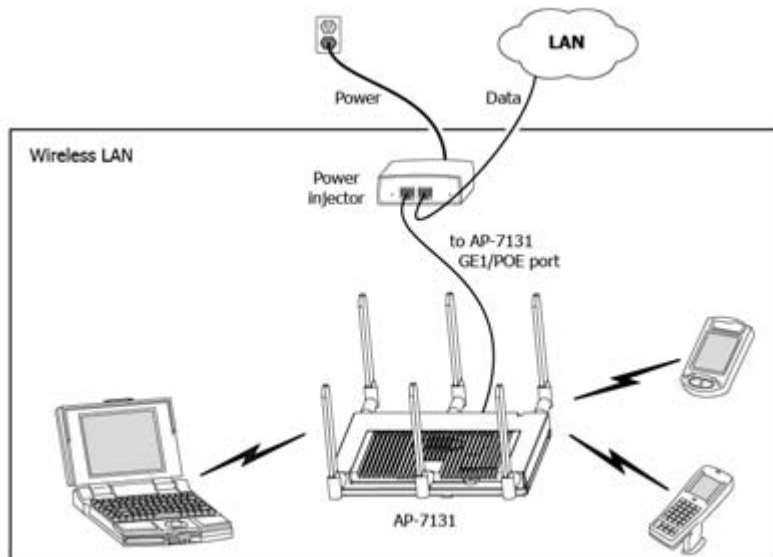

The Power Injector can be installed free standing, on an even horizontal surface or wall mounted using the power injector's wall mounting key holes. The following guidelines should be adhered to before cabling the Power Injector to an Ethernet source and an AP-7131:

- Do not block or cover airflow to the Power Injector.
- Keep the Power Injector away from excessive heat, humidity, vibration and dust.
- The Power Injector isn't a repeater, and does not amplify the Ethernet signal. For optimal performance, ensure the Power Injector is placed as close as possible to the data port.

To install the Power Injector to an Ethernet data source and AP-7131:



CAUTION Ensure AC power is supplied to the Power Injector using an AC cable with an appropriate ground connection approved for the country of operation.

1. Connect the Power Injector to an AC outlet (110VAC to 220VAC).
2. Connect an RJ-45 Ethernet cable between the network data supply (host) and the Power Injector **Data In** connector.
3. Connect an RJ-45 Ethernet cable between the Power Injector **Data & Power Out** connector and the AP-7131 GE1/POE port.



NOTE Cabling the Power Injector to the AP-7131's WAN port renders the AP-7131 non-operational. Only use a AP-PSBIAS-1P3-AFR model Power Injector with the AP-7131's GE1/POE (LAN) port.

Ensure the cable length from the Ethernet source (host) to the Power Injector and AP-7131 does not exceed 100 meters (333 ft).

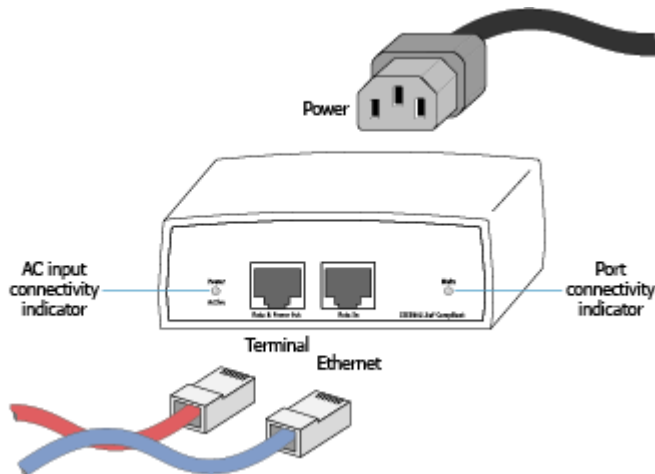

The Power Injector has no On/Off power switch. The Power Injector receives power and is ready for AP-7131 device connection and operation as soon as AC power is applied.

The Power Injector demonstrates the following LED behavior under normal and/or problematic operating conditions:

| LED | AC (Main) | Port |
|---------------------------|--|---|
| Green (<i>Steady</i>) | Power Injector is receiving power from AC outlet | Indicates a device is connected to the Power Injector's outgoing Data & Power cable |
| Green (<i>Blinking</i>) | Output voltage source is out of range | The Power Injector is overloaded or has a short circuit |

2.4 Mounting the AP-7131

The AP-7131 can attach to a wall, mount under a suspended T-Bar or above a ceiling (plenum or attic). Choose one of the following mounting options based on the physical environment of the coverage area. Do not mount the AP-7131 in a location that has not been approved in a site survey.

2.4.1 Wall Mounting

Wall mounting requires hanging the AP-7131 along its width (or length) using the pair of slots on the bottom of the unit and using the AP-7131 itself as a mounting template for the screws.



CAUTION An AP-7131 should be wall mounted to concrete or plaster-wall-board (dry wall) only. Do not wall mount an AP-7131 to combustible surfaces.

The hardware and tools (customer provided) required to install the AP-7131 on a wall consists of:

- Two Phillips pan head self-tapping screws (ANSI Standard) #6-18 X 0.875in. Type A or AB Self-Tapping screw, or (ANSI Standard Metric) M3.5 X 0.6 X 20mm Type D Self-Tapping screw
- Two wall anchors
- Wall mount template (included on the next page)
- Security cable (optional)

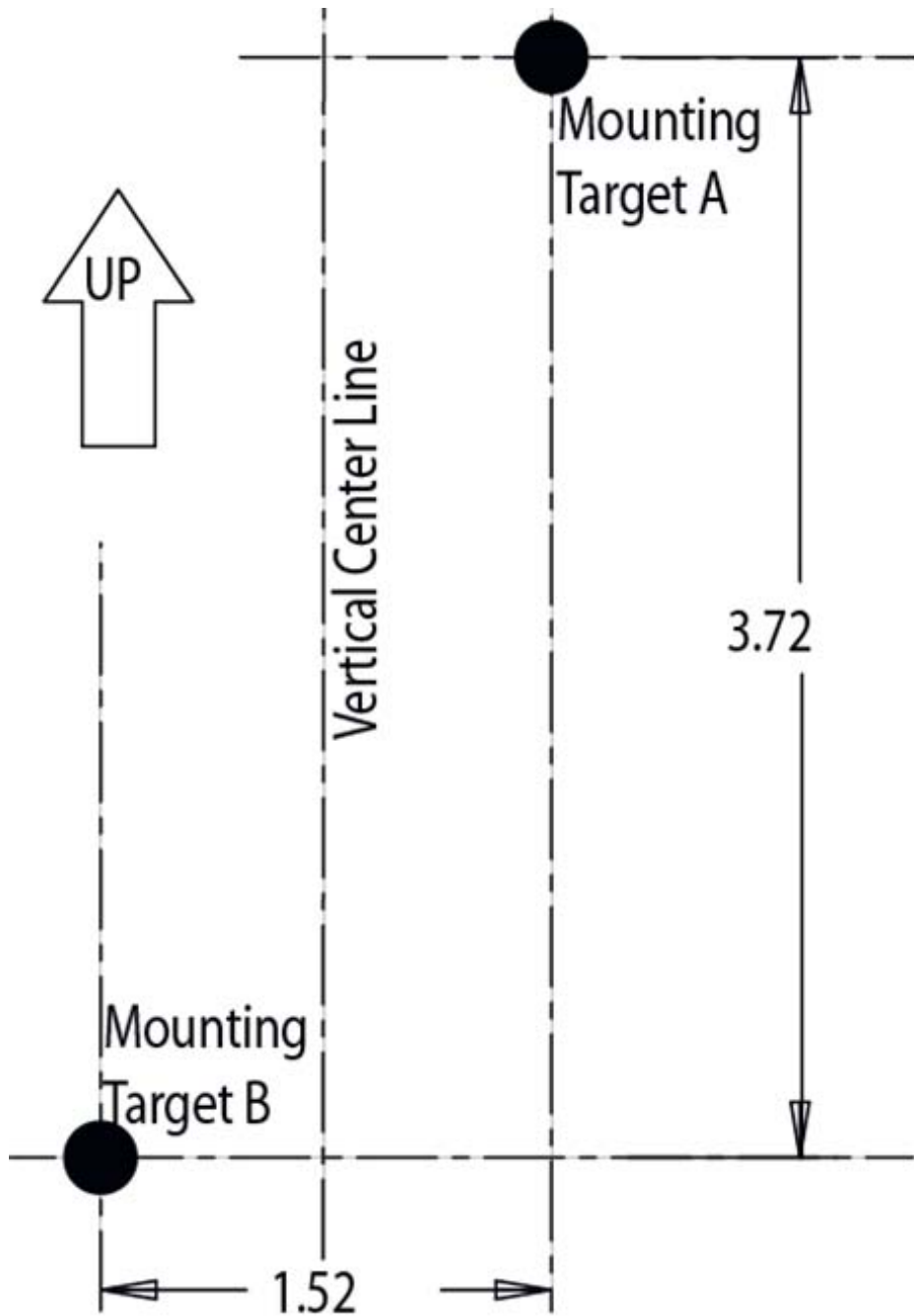

To mount the AP-7131 on a wall using the provided template:



CAUTION The procedure described in this section is exclusively for wall mount installations.

1. Xerox copy the template (on the previous page) to a blank piece of paper. Do not reduce or enlarge the scale of the template.
2. Tape the template to the wall mounting surface.
 - If the installation requires the antenna be positioned vertically, the centerline reference (of the template) needs to be positioned vertically. The cabling shall exit the access point in a vertical direction.
 - If the installation requires the antenna be positioned horizontally, the vertical centerline (of the template) needs to be positioned horizontally. The cabling shall exit the access point in a horizontal direction.
3. At mounting targets A and B, mark the mounting surface through the template at the target center.
4. Discard the mounting template.
5. At each point, drill a hole in the wall, insert an anchor, screw into the anchor the wall mounting screw and stop when there is 1mm between the screw head and the wall.

If pre-drilling a hole, the recommended hole size is 2.8mm (0.11in.) if the screws are going directly into the wall and 6mm (0.23in.) if wall anchors are being used.
6. If required, install and attach a security cable to the AP-7131 lock port.
7. Attach the antennas to their correct connectors.
8. For information on the antennas available to the AP-7131, see "**AP-7131 Antenna Options**" on page 5.
9. Place the large center opening of each of the mount slots over the screw heads.
10. Slide the AP-7131 down along the mounting surface to hang the mount slots on the screw heads.



CAUTION Ensure you are placing the antennas on the correct connectors (depending on your single or dual-radio model and frequency used) to ensure the successful operation of the AP-7131.



NOTE It is recommended the AP-7131 be mounted with the RJ45 cable connector oriented upwards or downwards to ensure proper operation.

11. Cable the AP-7131 using either the Power Injector solution or an approved line cord and power supply.

For Motorola Power Injector installations:

- a. Connect a RJ-45 CAT 5 Ethernet cable between the network data supply (host) and the Power Injector **Data In** connector.
- b. Connect a RJ-45 CAT 5 Ethernet cable between the Power Injector **Data & Power Out** connector and the AP-7131 GE1/POE port.
- c. Ensure the cable length from the Ethernet source (host) to the Power Injector and AP-7131 does not exceed 100 meters (333 ft). The Power Injector has no On/Off power switch. The Power Injector receives power as soon as AC power is applied. For more information on using the Power Injector, see “**Power Injector System**” on page 6.

For standard power adapter (non Power Injector) and line cord installations:

- a. Connect a RJ-45 CAT 5 Ethernet cable between the network data supply (host) and the AP-7131 GE1/POE or GE2 port.
- b. Verify the power adapter is correctly rated according the country of operation.
- c. Connect the power supply line cord to the power adapter.
- d. Attach the power adapter cable into the power connector on the AP-7131.
- e. Attach the power supply line cord to a power supply.



CAUTION Do not actually connect to the power source until the cabling portion of the installation is complete.

12. Verify the behavior of the AP-7131 LEDs. For more information, see “**LED Indicators**” on page 19.
13. The AP-7131 is ready to configure. For information on basic AP-7131 device configuration, see “**Configuring “Basic” Device Settings**” on page 24.

2.4.2 Suspended Ceiling T-Bar Installations

A suspended ceiling mount requires holding the AP-7131 up against the T-bar of a suspended ceiling grid and twisting the AP-7131 chassis onto the T-bar.

The mounting tools (customer provided) and hardware required to install the AP-7131 on a ceiling T-bar consists of:

- Safety wire (recommended and customer supplied)
- Security cable (optional and customer supplied)

To install the AP-7131 on a ceiling T-bar:

1. Motorola recommends you loop a safety wire — with a diameter of at least 1.01 mm (.04 in.), but no more than 0.158 mm (.0625 in.) — through the tie post (above the AP-7131's console connector) and secure the loop.
2. If desired, install and attach a security cable to the AP-7131 lock port.
3. Attach the antennas to their correct connectors.

For information on the antennas available to the AP-7131, see “**AP-7131 Antenna Options**” on page 5.



CAUTION Ensure you are placing the antennas on the correct connectors (depending on your single or dual-radio model and frequency used) to ensure the successful operation of the AP-7131.

4. Cable the AP-7131 using either the Power Injector solution or an approved line cord and power supply.

For Motorola Power Injector installations:

- a. Connect a RJ-45 CAT 5 Ethernet cable between the network data supply (host) and the Power Injector **Data In** connector.
- b. Connect a RJ-45 CAT 5 Ethernet cable between the Power Injector **Data & Power Out** connector and the AP-7131 GE1/POE port.
- c. Ensure the cable length from the Ethernet source (host) to the Power Injector and AP-7131 does not exceed 100 meters (333 ft). The Power Injector has no On/Off power switch. The Power Injector receives power as soon as AC power is applied. For more information, see “**Power Injector System**” on page 6.

For standard power adapter (non Power Injector) and line cord installations:

- a. Connect a RJ-45 Ethernet cable between the network data supply (host) and the AP-7131 GE1/POE or GE2 port.
- b. Verify the power adapter is correctly rated according the country of operation.
- c. Connect the power supply line cord to the power adapter.
- d. Attach the power adapter cable into the power connector on the AP-7131.
- e. Attach the power supply line cord to a power supply.



CAUTION Do not actually connect to the power source until the cabling portion of the installation is complete.

5. Verify the behavior of the AP-7131 LEDs. For more information, see “**LED Indicators**” on page 19.
6. Align the bottom of the ceiling T-bar with the back of the AP-7131.
7. Orient the AP-7131 chassis by its length and the length of the ceiling T-bar.
8. Rotate the AP-7131 chassis 45 degrees clockwise, or about 10 o'clock.
9. Push the back of the AP-7131 chassis on to the bottom of the ceiling T-bar.

10. Rotate the AP-7131 chassis 45 degrees counter-clockwise. The clips click as they fasten to the T-bar.

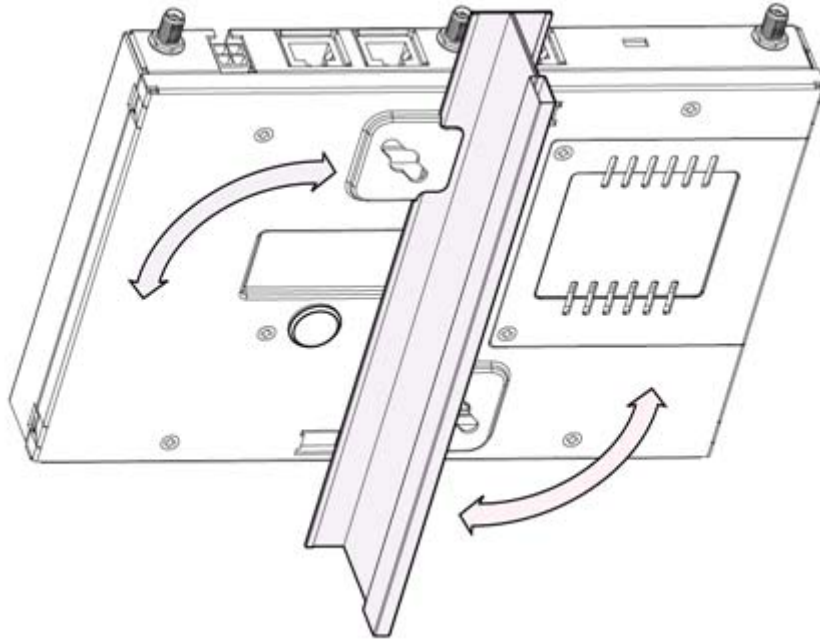

11. The AP-7131 is ready to configure. For information on basic AP-7131 device configuration, see "**Configuring "Basic" Device Settings**" on page 24.



NOTE If the AP-7131 is utilizing remote management antennas, a wire cover can be used to provide a clean finished look to the installation. Contact Motorola for more information.

2.4.3 Above the Ceiling (Plenum) Installations

An AP-7131 above the ceiling installation requires placing the AP-7131 above a suspended ceiling and installing the provided light pipe under the ceiling tile for viewing the rear panel status LEDs of the unit. An above the ceiling AP-7131 installation enables installations compliant with drop ceilings, suspended ceilings and industry standard tiles from .625 to .75 inches thick.



NOTE The AP-7131 is Plenum rated to UL2043 and NEC1999 for above the ceiling installations.



CAUTION Motorola does not recommend mounting the AP-7131 directly to any suspended ceiling tile with a thickness less than 12.7mm (0.5in.) or a suspended ceiling tile with an unsupported span greater than 660mm (26in.). Motorola strongly recommends fitting the AP-7131 with a safety wire suitable for supporting the weight of the device. The safety wire should be a standard ceiling suspension cable or equivalent steel wire between 1.59mm (.062in.) and 2.5mm (.10in.) in diameter.

The mounting hardware required to install the AP-7131 above a ceiling consists of:

- Light pipe
- Badge for light pipe
- Decal for badge
- Safety wire (strongly recommended)
- Security cable (optional)

To install the AP-7131 above a ceiling:

1. If possible, remove the adjacent ceiling tile from its frame and place it aside.
2. If required, install a safety wire, between 1.5mm (.06in.) and 2.5mm (.10in.) in diameter, in the ceiling space.
3. If required, install and attach a security cable to the AP-7131's lock port.
4. Mark a point on the finished side of the tile where the light pipe is to be located.
5. Create a light pipe path hole in the target position on the ceiling tile.
6. Use a drill to make a hole in the tile the approximate size of the AP-7131 LED light pipe.



CAUTION Motorola recommends care be taken not to damage the finished surface of the ceiling tile when creating the light pipe hole and installing the light pipe.

7. Remove the light pipe's rubber stopper (from the AP-7131) before installing the light pipe.

8. Connect the light pipe to the bottom of the AP-7131. Align the tabs and rotate approximately 90 degrees. Do not over tighten.

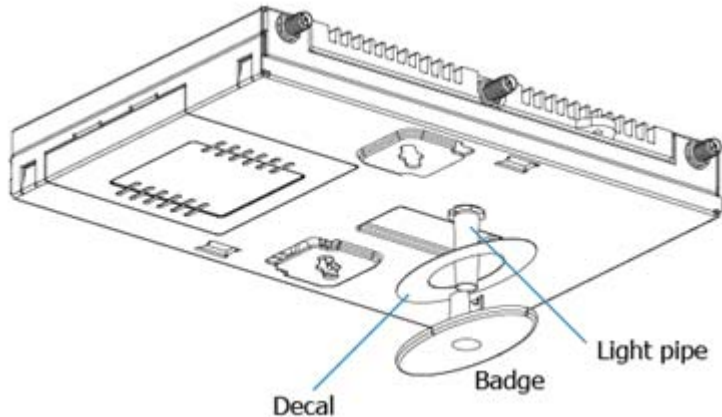

9. Fit the light pipe into hole in the tile from its unfinished side.
10. Place the decal on the back of the badge and slide the badge onto the light pipe from the finished side of the tile.
11. Attach the antennas to their correct connectors.
For information on the antennas available to the AP-7131, see "**AP-7131 Antenna Options**" on page 5.



CAUTION Ensure you are placing the antennas on the correct connectors (depending on your single or dual-radio model and frequency used) to ensure the successful operation of the AP-7131.

12. Motorola recommends attaching safety wire to the AP-7131 safety wire tie point or security cable (if used) to the AP-7131's lock port.
13. Align the ceiling tile into its former ceiling space.
14. Cable the AP-7131 using either the Power Injector solution or an approved line cord and power supply.

For Motorola Power Injector installations:

- a. Connect a RJ-45 CAT 5 Ethernet cable between the network data supply (host) and the Power Injector **Data In** connector.
- b. Connect a RJ-45 CAT 5 Ethernet cable between the Power Injector **Data & Power Out** connector and the AP-7131 GE1/POE port.

- c. Ensure the cable length from the Ethernet source (host) to the Power Injector and AP-7131 does not exceed 100 meters (333 ft). The Power Injector has no On/Off power switch. The Power Injector receives power as soon as AC power is applied. For more information on using the Power Injector, see "**Power Injector System**" on page 6.

For standard power adapter (non Power Injector) and line cord installations:

- a. Connect a RJ-45 Ethernet cable between the network data supply (host) and the AP-7131 GE1/POE or GE2 port.
- b. Verify the power adapter is correctly rated according the country of operation.
- c. Connect the power supply line cord to the power adapter.
- d. Attach the power adapter cable into the power connector on the AP-7131.
- e. Attach the power supply line cord to a power supply.



CAUTION Do not actually connect to the power source until the cabling portion of the installation is complete.

15. Verify the behavior of the AP-7131 LED light pipe. For more information, see "**LED Indicators**" on page 19.
16. Place the ceiling tile back in its frame and verify it is secure.
17. The AP-7131 is ready to configure. For information on basic AP-7131 device configuration, see "**Configuring "Basic" Device Settings**" on page 24.

2.5 LED Indicators

Six LEDs illuminate on the front of the AP-7131 (on top of the AP-7131 housing) for dual radio models and five illuminate for single radio models. Two LEDs (for above the ceiling installations) are located on the back of the device.

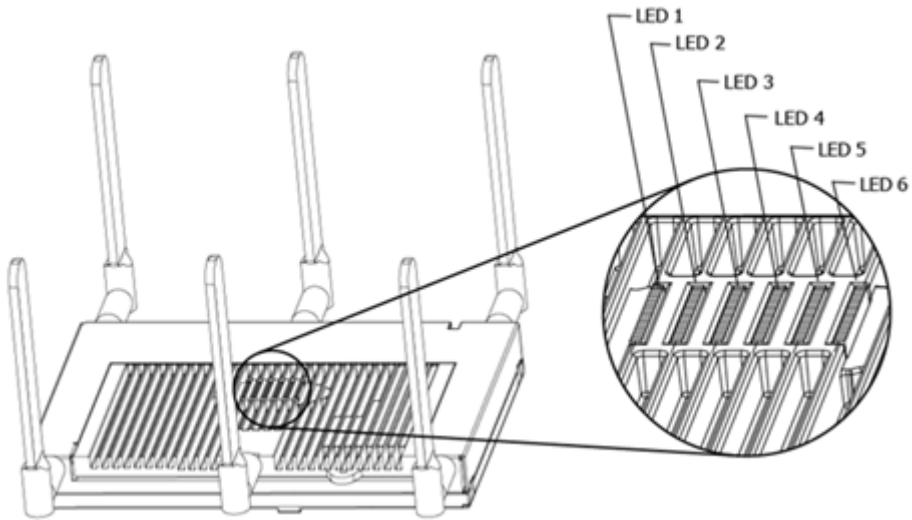

The LEDs on the top housing of the AP-7131 are clearly visible in wall and below ceiling installations. The top housing LEDs have the following display and functionality:

2.5.1 Dual Radio (2.4/5.2 Ghz) AP-7131 With Sensor Slot LEDs

A dual radio (2.4/5.2 Ghz) model AP-7131 has the following unique LED behavior:

| LED 1 | LED 2 | LED 3 | LED 4 | LED 5 | LED 6 |
|--|---|---|--|--|--|
| Blinking Red indicates booting. Solid Red defines a failure condition. White defines normal operation | Green defines normal GE1 operation. Yellow defines a collision | Green defines normal GE2 operation. Yellow defines a collision | Amber defines 5.2 Ghz radio as configured | Emerald defines 2.4 Ghz radio as configured | Amber 5.2 Ghz radio as present and scanning Emerald 2.4 Ghz radio as present and scanning |

2.5.2 Single Radio 2.4 Ghz AP-7131 LEDs

The single 2.4 Ghz radio model AP-7131 has the following unique LED behavior:

| LED 1 | LED 2 | LED 3 | LED 4 | LED 5 |
|---|---|---|--|--|
| Blinking Red indicates booting. Solid Red defines a failure condition. White defines normal operation | Green defines normal GE1 operation. Yellow defines a collision | Green defines normal GE2 operation. Yellow defines a collision | Amber defines 5.2 Ghz radio as configured | Emerald defines 2.4 Ghz radio as configured |

2.5.3 Single Radio 5.2 Ghz AP-7131 LEDs

The single 5.2 Ghz radio model AP-7131 has the following unique LED behavior:

| LED 1 | LED 2 | LED 3 | LED 4 | LED 5 |
|--|--|--|--|--|
| Blinking Red indicates booting. Solid Red defines a failure condition. White defines normal operation | Green defines normal GE1 operation. Yellow defines a collision | Green defines normal GE2 operation. Yellow defines a collision | Amber defines 5.2 Ghz radio as configured | Emerald defines 2.4 Ghz radio as configured |

2.5.4 Rear AP-7131 LED

The LED on the rear (bottom) of the AP-7131 is viewed using a single (customer installed) extended light pipe, adjusted as required to suit above the ceiling installations. A LED displayed using the light pipe has the following display and functionality:

| LED 1 |
|--|
| White/Red defining power and boot status |

3 Basic AP-7131 Configuration

For the basic setup described in this guide, the Java-based Web UI will be used to configure the AP-7131. To access the AP-7131 via the GE1/POE port, the GE1/POE port default setting is DHCP client. For this example, the AP-7131's WAN interface will be used to connect to the access point. The default WAN IP address is 10.1.1.1. For optimal viewing of the AP-7131 Web UI, the screen resolution should be set to 1024 x 768 pixels or greater.



NOTE For advanced configuration options beyond the scope of this guide, refer to the *AP-7131 Product Reference Guide*. The guide is available on the Motorola Web site, at <http://support.symbol.com/support/product/manuals.do>.

1. Start a browser and enter the following IP address in the address field:

http://10.1.1.1



NOTE For optimum compatibility, use Sun Microsystems' JRE 1.5 or higher (available from Sun's Website), and be sure to disable Microsoft's Java Virtual Machine if installed.

The AP-7131 login screen displays.



2. Log in using **admin** as the default User ID and **motorola** as the default password. If the default login is successful, the **Change Admin Password** window displays.
3. Change the password.

Enter the current password and a new admin password in fields provided, and click **Apply**. Once the admin password has been updated, a warning message displays stating the AP-7131 could be operating illegally unless set to operate in the correct country. Proceed to **“Configuring “Basic” Device Settings”** on page 24 to validate the country setting.



NOTE Though the AP-7131 can have its basic settings defined using a number of different screens, Motorola recommends using the **AP-7131 Quick Setup** screen to define a minimum required configuration from one location.

3.1 Resetting the AP-7131 Password

The AP-7131 *Command Line Interface* (CLI) enables users who forget their password to reset it to the factory default (motorola). From there, a new password can be defined. To reset the AP-7131 password back to its default setting:

1. Connect one end of a null modem serial cable to the AP-7131's serial connector. Attach the other end of the null modem serial cable to the serial port of a PC running HyperTerminal or a similar emulation program.
2. Set the HyperTerminal program to use 19200 baud, 8 data bits, 1 stop bit, no parity, no flow control and auto-detect for terminal emulation.
3. Press <ESC> or <Enter> to access the AP-7131 CLI. A serial connection has now been established and the user should be able to view the serial connection window.
4. Reset the AP-7131. An AP-7131 can be reset by removing and re-inserting the LAN (GE1/POE) cable or removing and re-inserting the power cable.

As the AP-7131 is re-booting, a “Press esc key to run boot firmware” message displays.

5. Quickly press <ESC>.



CAUTION If the <ESC> key is not pressed within three seconds after the “Press esc key to run boot firmware” message displays, the AP-7131 will continue to boot.

If the <ESC> key is pressed within three seconds a boot> prompt displays.

6. Reset the AP-7131 by typing the following at the boot prompt: **reset system**

When the AP-7131 re-boots again, the password will return to its default value of “motorola.” You can now access the AP-7131.

3.2 Configuring “Basic” Device Settings

Configure a set of minimum required device settings within the **AP-7131 Quick Setup** screen. The values defined within the Quick Setup screen are also configurable in numerous other locations within the AP-7131 menu tree. When you change the settings in the Quick Setup screen, the values also change within the screen where these parameters also exist. Additionally, if the values are updated in these other screens, the values initially set within the Quick Setup screen will be updated. The following table illustrates the AP-7131’s default configuration.

| | WAN | LAN 1 | LAN 2 | Access via WAN port |
|--|--|--|--------------|---|
| | Static IP: 10.1.1.1 Static Mask: 255.0.0.0 | DHCP Client Auto-Update Enabled Default Gateway Ethernet Port Enabled | Disabled | HTTP, HTTPS, SSH, SNMP, Telnet: Enabled |

To define a basic AP-7131 configuration:

1. Select **System Configuration** -> **Quick Setup** from the AP-7131 menu tree.

2. Enter a **System Name** for the AP-7131. The System Name is useful if multiple devices are being administered.
3. Select the **Country** for the AP-7131's country of operation from the drop-down menu.

The AP-7131 prompts the user for the correct country code on the first login. A warning message also displays stating that an incorrect country setting may result in illegal radio operation. Selecting the correct country is central to legally operating the AP-7131. Each country has its own regulatory restrictions concerning electromagnetic emissions and the maximum RF signal strength that can be transmitted. To ensure compliance with national and local laws, be sure to set the Country accurately. CLI and MIB users cannot configure their AP-7131 until a two character country code (for example, United States - us) is set.



NOTE The System Name and Country are also configurable within the **System Settings** screen. Refer to the *AP-7131 Product Reference Guide* to optionally set a system location and admin email address for the AP-7131 or to change other default settings.

4. Optionally enter the IP address of the server used to provide system time to the AP-7131 within the Time Server field.

Once the IP address is entered, the AP-7131's *Network Time Protocol (NTP)* functionality is engaged automatically. Refer to the *AP-7131 Product Reference Guide* for information on defining alternate time servers and setting a synchronization interval for the AP-7131 to adjust its displayed time.

5. Click the **WAN** tab to set a minimum set of parameters for using the WAN interface.
 - a. Select the **Enable WAN Interface** checkbox to enable a connection between the AP-7131 and a larger network or outside world through the WAN port. Disable this option to effectively isolate the AP-7131's WAN connection. No connections to a larger network or the Internet will be possible. MUs cannot communicate beyond the configured subnets.
 - b. Select the **This Interface is a DHCP Client** checkbox to enable DHCP for the AP-7131 WAN connection. This is useful, if the target corporate network or *Internet Service Provider (ISP)* uses DHCP. DHCP is a protocol that includes mechanisms for IP address allocation and delivery of host-specific configuration parameters from a DHCP server to a host. Some of these parameters are IP address, network mask, and gateway.
 - c. Specify an **IP address** for the AP-7131's WAN connection. An IP address uses a series of four numbers expressed in dot notation, for example, 190.188.12.1.
 - d. Specify a **Subnet Mask** for the AP-7131's WAN connection. This number is available from the ISP for a DSL or cable-modem connection, or from an administrator if the AP-7131 connects to a larger network. A subnet mask uses a series of four numbers expressed in dot notation. For example, 255.255.255.0 is a valid subnet mask.
 - e. Specify a **Default Gateway** address for the AP-7131's WAN connection. The ISP or a network administrator provides this address.
 - f. Specify the address of a **Primary DNS Server**. The ISP or a network administrator provides this address.
6. Optionally, use the **Enable PPP over Ethernet** checkbox to enable *Point-to-Point over Ethernet (PPPoE)* for a high-speed connection that supports this protocol. Most DSL providers are currently using or deploying this protocol. PPPoE is a data-link protocol for dialup connections. PPPoE will allow the AP-7131 to use a broadband modem (DSL, cable modem, etc.) for access to high-speed data networks.
 - a. Select the **Keep Alive** checkbox to enable occasional communications over the WAN port even when client communications to the WAN are idle. Some ISPs terminate inactive connections, while others do not. In either case, enabling Keep-Alive maintains

- the WAN connection, even when there is no traffic. If the ISP drops the connection after the idle time, the AP-7131 automatically reestablishes the connection to the ISP.
- b. Specify a **Username** entered when connecting to the ISP. When the Internet session begins, the ISP authenticates the username.
 - c. Specify a **Password** entered when connecting to the ISP. When the Internet session starts, the ISP authenticates the password.
7. Click the **LAN** tab to set a minimum set of parameters to use the AP-7131 LAN interface.
 - a. Select the **Enable LAN Interface** checkbox to forward data traffic over the AP-7131 LAN connection. The LAN connection is enabled by default.
 - b. Use the **This Interface** drop-down menu to specify how network address information is defined over the AP-7131's LAN connection. Select **DHCP Client** if the larger corporate network uses DHCP. DHCP is a protocol that includes mechanisms for IP address allocation and delivery of host-specific configuration parameters from a DHCP server to a host. Some of these parameters are IP address, network mask, and gateway. Select **DHCP Server** to use the AP-7131 as a DHCP server over the LAN connection.
 - c. Enter the network-assigned **IP Address** of the AP-7131.
 - d. The **Subnet Mask** defines the size of the subnet. The first two sets of numbers specify the network domain, the next set specifies the subset of hosts within a larger network. These values help divide a network into subnetworks and simplify routing and data transmission.
 - e. Enter a **Default Gateway** to define the IP address of a router the AP-7131 uses on the Ethernet as its default gateway.
 - f. Enter the **Primary DNS Server** IP address.
 - g. If using DHCP Server, use the **Address Assignment Range** parameter to specify a range of IP address reserved for mapping clients to IP addresses. If a manually (static) mapped IP address is within the IP address range specified, that IP address could still be assigned to another client. To avoid this, ensure all statically mapped IP addresses are outside of the IP address range assigned to the DHCP server.



NOTE For additional AP-7131 port configuration options, as well as radio, WLAN and Quality of Service (QoS) options, refer to the *AP-7131 Product Reference Guide*.

8. Enable the radio(s) using the **Radio Enable** checkbox(es). If using a single radio model, enable the radio, then select either 802.11a (5 GHz) or 802.11b/g (2.4 GHz) from the **RF Band**

of Operation field. Only one RF band option at a time is permissible in a single-radio model. If using a dual-radio AP-7131, the user can enable both RF bands.

9. Select the **WLAN #1** tab (WLANs 1 - 4 are available within the Quick Setup screen) to define its ESSID security scheme for basic operation.



NOTE A maximum of 16 WLANs are configurable within the AP-7131 Wireless Configuration screen. The limitation of 16 WLANs exists regardless of the number of radios supported.

- a. Enter the *Extended Services Set Identification (ESSID)* and name associated with the WLAN.
 - b. Use the **Available On** checkboxes to define whether the target WLAN is operating over the 802.11a or 802.11b/g radio. Ensure the radio selected has been enabled (see step 8).
10. Once the WLAN's radio designations have been made, the radio must be configured in respect to intended 2.4 or 5 GHz radio traffic and the antennas used. Refer to **Network Configuration** -> **Wireless** -> **Radio Configuration** -> **Radio1 (or Radio2)**, and configure the Radio Settings field (at a minimum). If you know the radio's Properties, Performance and Beacon Settings, those fields can also be defined at this time. Define the Channel Settings, Power Level and 802.11 mode in respect to the 2.4 or 5 GHz 802.11b/g/n or 802.11a/n radio traffic and anticipated gain of the antennas.



CAUTION Only a qualified wireless network administrator should set the access point radio configuration. Refer to the *AP-7131 Product Reference Guide* for an understanding of the configurable values involved and their implications. To access the guide, go to <http://support.symbol.com/support/product/manuals.do>.



NOTE Even an AP-7131 configured with minimal values must protect its data against theft and corruption. A security policy should be configured for WLAN1 as part of the basic configuration outlined in this guide. A security policy can be configured for the WLAN from within the Quick Setup screen. Policies can be defined over time and saved to be used as needed as the AP-7131's security requirements change. Motorola recommends you familiarize yourself with the security options available on the AP-7131 before defining a security policy.

11. Click **Apply** to save any changes to the AP-7131 Quick Setup screen. Navigating away from the screen without clicking Apply results in all changes to the screens being lost, unless you use the **Un-applied Changes** pop-up window to overwrite the current settings.
12. Click **Undo Changes** (if necessary) to undo any changes made. Undo Changes reverts the settings displayed on the AP-7131 Quick Setup screen to the last saved configuration.

3.2.1 Configuring Basic AP-7131 Security

For testing basic connectivity, there is no reason to configure a server supported authentication scheme. WEP 128 is described in this guide as a basic security scheme sufficient to protect the AP-7131's initial transmissions. For details on configuring more sophisticated authentication and encryption options available to the AP-7131, refer to the *AP-7131 Product Reference Guide*. The guide is available on the Motorola Web site, at <http://support.symbol.com/support/product/manuals.do>.

To configure WEP 128:

1. From the AP-7131 Quick Setup screen, click the **Create** button to the right of the Security Policy item.

The **New Security Policy** screen displays with the **Manually Pre-shared key/No authentication** and **No Encryption** options selected. Naming and saving such a policy (as is) would provide no security and might only make sense in a guest network wherein no sensitive data is either transmitted or received. Consequently, at a minimum, a basic security scheme (in this case WEP 128) is recommended.



NOTE For information on configuring the other (more sophisticated) encryption and authentication options available to the AP-7131, refer to the *AP-7131 Product Reference Guide*. The guide is available on the Motorola Web site, at <http://support.symbol.com/support/product/manuals.do>.

2. Ensure the **Name** of the security policy entered suits the intended configuration or function of the policy.

Multiple WLANs can share the same security policy, so be careful not to name security policies after specific WLANs or risk defining a WLAN to single policy. Motorola recommends naming the policy after the attributes of the authentication or encryption type selected.

- Select the **WEP 128 (104 bit key)** checkbox. The **WEP 128 Setting** field displays within the New Security Policy screen.

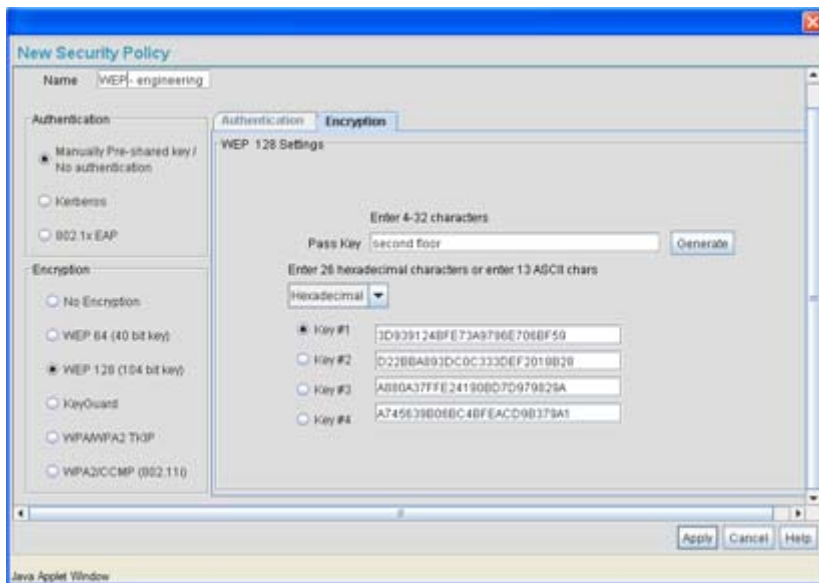

- Configure the **WEP 128 Setting** field as required to define the Pass Key used to generate the WEP keys.

Pass Key

Specify a 4 to 32 character pass key and click the **Generate** button. The AP-7131, other proprietary routers and Motorola MUs use the same algorithm to convert an ASCII string to the same hexadecimal number. Non-Motorola clients and devices need to enter WEP keys manually as hexadecimal numbers. The AP-7131 and its target client(s) must use the same pass key to interoperate.

Keys #1-4

Use the **Key #1-4** fields to specify key numbers. The key can be either a hexadecimal or ASCII depending on which option is selected from the drop-down menu. For WEP 64 (40-bit key), the keys are 10 hexadecimal characters in length or 5 ASCII characters. For WEP 128 (104-bit key), the keys are 26 hexadecimal characters in length or 13 ASCII characters. Select one of these keys for activation by clicking its radio button. The AP-7131 and its target client(s) must use the same key to interoperate.

- Click the **Apply** button to save the security policy and return to the **AP-7131 Quick Setup** screen.

At this point, you can either restrict specific MU access to the AP-7131 (using the AP-7131 ACL) or test the AP-7131 for MU interoperability.

3.2.2 Excluding MUs from AP-7131 Association

Optionally, use the AP-7131 *Access Control List ACL* to specify which MUs can or cannot gain access to an AP-7131 managed WLAN. By default, all mobile units can gain access. For specific information on configuring (restricting) MU access, refer to the *AP-7131 Product Reference Guide*. The guide is available on the Motorola Web site, at <http://support.symbol.com/support/product/manuals.do>.

3.2.3 Testing Mobile Unit Connectivity

Verify the AP-7131's link with an MU by sending *Wireless Network Management Protocol* (WNMP) ping packets to the associated MU. Use the **Echo Test** screen to specify a target MU and configure the parameters of the ping test. The WNMP ping test only works with Motorola MUs. Only use a Motorola MU to test AP-7131 connectivity using WNMP.

To ping a specific MU to assess its connection with an AP-7131:



NOTE Before testing for connectivity, the target MU needs to be set to the same ESSID as the AP-7131. Since WEP 128 has been configured for the AP-7131, the MU also needs to be configured for WEP 128 and use the same WEP keys. Ensure the MU is associated with the AP-7131 before testing for connectivity.

1. Select **Status and Statistics** - > **MU Stats** from the AP-7131 menu tree.
2. Select the **Echo Test** button from within the **MU Stats Summary** screen.
3. Define the following ping test parameters:

Station Address The station address is the IP address of the target MU. Refer to the **MU Stats Summary** screen for associated MU IP address information.

Number of ping Specify the number of ping packets to transmit to the target MU. The default is 100.

Packet Length Specify the length of each data packet transmitted to the target MU during the ping test. The default is 100 bytes.

4. Click the **Ping** button to begin transmitting ping packets to the MU address specified.

Refer to the **Number of Responses** value to assess the number of responses from the target MU versus the number of pings transmitted by the AP-7131. Use the ratio of packets sent versus packets received to assess the link quality between MU and the AP-7131.

Click the **Ok** button to exit the Echo Test screen and return to the MU Stats Summary screen.

With basic AP-7131 and associated MU connectivity verified, the AP-7131 is now ready to operate as defined within this guide or have its more advanced features configured.

3.3 Where to Go From Here?

Once basic connectivity has been verified, the AP-7131 can be fully configured to meet the needs of the network and the users it supports. The sections referenced below are located within the *AP-7131 Product Reference Guide*. The guide is available on the Motorola Web site, at <http://support.symbol.com/support/product/manuals.do>.

- Refer to Chapter 4 to define System Settings (beyond the scope of the Quick Setup screen), configure AP-7131 device access, set SNMP values, log system events, set the AP-7131 system time and import device firmware and configuration files.
- See Chapter 5 for information on configuring the AP-7131 LAN and WAN ports, define up to 16 individual WLANs and their QoS policies and configure AP-7131 router settings.
- Refer to Chapter 6 for detailed information on configuring specific encryption (WEP, KeyGuard, WPA/TKIP and WPA2/CCMP) and authentication (Kerberos and 802.1x EAP) security schemes.
- See Chapter 7 for information on accessing statistics helpful in monitoring the connection between the AP-7131 and its connected devices.
- Refer to Chapter 8 for information on using the AP-7131 *Command Line Interface (CLI)*, as accessed through the serial port or Telnet.
- See Appendix A for device specifications.

4 Regulatory Compliance

This device is approved under the Symbol Technologies brand; Symbol Technologies, Inc., is the Enterprise Mobility business of Motorola, Inc (“Motorola”).

All Motorola devices are designed to be compliant with rules and regulations in locations they are sold and will be labeled as required. Any changes or modifications to Motorola equipment, not expressly approved by Motorola, could void the user's authority to operate the equipment.

Motorola's devices are professionally installed, the Radio Frequency Output Power will not exceed the maximum allowable limit for the country of operation.

Antennas: Use only the supplied or an approved replacement antenna. Unauthorized antennas, modifications, or attachments could cause damage and may violate regulations.

This guide is available in local languages, translations can be downloaded from the following website:

<http://support.symbol.com/support/product/manuals.do>.

Country Approvals

Regulatory markings are applied to the device signifying the radio (s) are approved for use in the following countries: United States, Canada, Australia, Japan and Europe.

Please refer to the *Declaration of Conformity* (DoC) for details of other country markings. This is available at

<http://www2.symbol.com/doc/>.

Note 1: For 2.4GHz Products: Europe includes, Austria, Belgium, Bulgaria, Czech Republic, Cyprus, Denmark, Estonia, Finland, France, Germany, Greece, Hungary, Iceland, Ireland, Italy, Latvia, Liechtenstein, Lithuania, Luxembourg, Malta, Netherlands, Norway, Poland, Portugal, Romania, Slovak Republic, Slovenia, Spain, Sweden, Switzerland and the United Kingdom.



Operation of the device without regulatory approval is illegal.

Health and Safety Recommendations



Warnings for the use of Wireless Devices

Please observe all warning notices with regard to the usage of wireless devices

Potentially Hazardous Atmospheres

You are reminded of the need to observe restrictions on the use of radio devices in fuel depots, chemical plants etc. and areas where the air contains chemicals or particles (such as grain, dust, or metal powders).



Safety in Hospitals

Wireless devices transmit radio frequency energy and may affect medical electrical equipment. When installed adjacent to other equipment, it is advised to verify that the adjacent equipment is not adversely affected.

RF Exposure Guidelines

Safety Information

The device complies with Internationally recognized standards covering human exposure to electromagnetic fields from radio devices.

Reducing RF Exposure—Use Properly

Only operate the device in accordance with the instructions supplied.

Remote and Standalone Antenna Configurations

To comply with FCC RF exposure requirements, antennas that are mounted externally at remote locations or operating near users at stand-alone desktop of similar configurations must operate with a minimum separation distance of 20 cm from all persons.

Power Supply

Use only a Motorola approved power supply output rated at 48Vdc and minimum 0.75A. The power supply shall be Listed to UL/CSA 60950-1; and certified to IEC60950-1 and EN60950-1 with SELV outputs.

Use only a Motorola approved power supply. Use of alternative power supply will invalidate any approval given to this device and may be dangerous.

Wireless Devices - Countries

Country Selection

Select only the country in which you are using the device. Any other selection will make the operation of this device illegal.

Operation in the US

The use on UNII (Unlicensed National Information Infrastructure) Band 1 5150-5250 MHz is restricted to indoor use only, any other use will make the operation of this device illegal.

The available channels for 802.11 b/g operation in the US are Channels 1 to 11. The range of channels is limited by firmware.

Radio Frequency Interference Requirements—FCC



This equipment has been tested and found to comply with the limits for a Class B digital device, pursuant to Part 15 of the FCC rules. These limits are designed to provide reasonable protection against harmful interference in a residential installation. This equipment generates, uses and can radiate radio frequency energy and, if not installed and used in accordance with the instructions, may cause harmful interference to radio communications. However there is no guarantee that interference will not occur in a particular installation. If this equipment does cause harmful interference to radio or television reception, which can be determined by turning the equipment off and on, the user is encouraged to try to correct the interference by one or more of the following measures:

- Reorient or relocate the receiving antenna
- Increase the separation between the equipment and receiver
- Connect the equipment into an outlet on a circuit different from that to which the receiver is connected
- Consult the dealer or an experienced radio/TV technician for help.

Radio Transmitters (Part 15)

This device complies with Part 15 of the FCC Rules. Operation is subject to the following two conditions: (1) this device may not cause harmful interference, and (2) this device must accept any interference received, including interference that may cause undesired operation.

Radio Frequency Interference Requirements – Canada

This Class B digital apparatus complies with Canadian ICES-003.

Cet appareil numérique de la classe B est conforme à la norme NMB-003 du Canada.

Devices using the 5.470 – 5.725 GHz band shall not be capable of transmitting in the band 5.60-5.65 GHz in Canada, make sure that Canada is the country selected during setup to ensure compliance.

Radio Transmitters

This device complies with RSS 210 of Industry & Science Canada. Operation is subject to the following two conditions: (1) this device may not cause harmful interference and (2) this device must accept any interference received, including interference that may cause undesired operation.

To reduce potential radio interference to other users, the antenna type and its gain should be so chosen that the equivalent isotropically radiated power (EIRP) is not more than that permitted for successful communication.

This device has been designed to operate with the antennas listed in section 3.3.1 of this installation guide, and having a maximum gain of 13.9 dBi (2.4 GHz) and 13 dBi (5 GHz). Antennas not included in this list or having a gain greater than 13.9 dBi (2.4 GHz) and 13 dBi (5 GHz) are strictly prohibited for use with this device. The required antenna impedance is 50 ohms.

Label Marking: The Term "IC:" before the radio certification signifies that Industry Canada technical specifications were met.

CE Marking and European Economic Area (EEA)

The use of 2.4GHz WLAN's, for use through the EEA, have the following restrictions:

- Maximum radiated transmit power of 100 mW EIRP in the frequency range 2.400 -2.4835 GHz.
- France outside usage, the equipment is restricted to 2.400-2.45 GHz frequency range.
- Italy requires a user license for outside usage.

Statement of Compliance

Motorola hereby, declares that this device is in compliance with the essential requirements and other relevant provisions of Directive 1999/5/EC. A Declaration of Conformity may be obtained from <http://www2.symbol.com/doc/>.

NOTICE!

According to: Administrative Regulations on Low Power Radio Waves Radiated Devices

Article 12

Without permission granted by the DGT, any company, enterprise, or user is not allowed to change frequency, enhance transmitting power or alter original characteristic as well as performance to a approved low power radio-frequency devices.

Article 14

The low power radio-frequency devices shall not influence aircraft security and interfere legal communications; If found, the user shall cease operating immediately until no interference is achieved. The said legal communications means radio communications is operated in compliance with the Telecommunications Act. The low power radio-frequency devices must be susceptible with the interference from legal communications or ISM radio wave radiated devices.

FCC Caution: Any changes or modifications not expressly approved by the party responsible for compliance could void the user's authority to operate this equipment.

Country Code Statement

For product available in the USA/Canada market, only channel 1~11 can be operated. Selection of other channels is not possible.

This device and its antenna(s) must not be co-located or operation in conjunction with any other antenna or transmitter.

For IEEE 802.11a 5GHz Statement

This device is going to be operated in 5.15~5.25GHz frequency range, it is restricted in indoor environment only.

For MPE Statement – Mobile device

IMPORTANT NOTE:

FCC Radiation Exposure Statement:

This equipment complies with FCC radiation exposure limits set forth for an uncontrolled environment. This equipment should be installed and operated with minimum distance 20cm between the radiator & your body.

5 Waste Electrical and Electronic Equipment (WEEE)

English: For EU Customers: All products at the end of their life must be returned to Symbol for recycling. For information on how to return product, please go to: http://www.symbol.com/environmental_compliance.

Čeština: Pro zákazníky z EU: Všechny produkty je nutné po skončení jejich životnosti vrátit společnosti Symbol k recyklaci. Informace o způsobu vrácení produktu najdete na webové stránce: http://www.symbol.com/environmental_compliance.

Dansk: Til kunder i EU: Alle produkter skal returneres til Symbol til recirkulering, når de er udtjent. Læs oplysningerne om returnering af produkter på: http://www.symbol.com/environmental_compliance.

Deutsch: Für Kunden innerhalb der EU: Alle Produkte müssen am Ende ihrer Lebensdauer zum Recycling an Symbol zurückgesandt werden. Informationen zur Rücksendung von Produkten finden Sie unter http://www.symbol.com/environmental_compliance.

Eesti: EL klientidele: kõik tooted tuleb nende eluea lõppedes tagastada taaskasutamise eesmärgil Symbol'ile. Lisainformatsiooni saamiseks toote tagastamise kohta külastage palun aadressi: http://www.symbol.com/environmental_compliance.

Español: Para clientes en la Unión Europea: todos los productos deberán entregarse a Symbol al final de su ciclo de vida para que sean reciclados. Si desea más información sobre cómo devolver un producto, visite: http://www.symbol.com/environmental_compliance.

Ελληνικά: Για πελάτες στην Ε.Ε.: Όλα τα προϊόντα, στο τέλος της διάρκειας ζωής τους, πρέπει να επιστρέφονται στην Symbol για ανακύκλωση. Για περισσότερες πληροφορίες σχετικά με την επιστροφή ενός προϊόντος, επισκεφθείτε τη διεύθυνση http://www.symbol.com/environmental_compliance στο Διαδίκτυο.

Français : Clients de l'Union Européenne : Tous les produits en fin de cycle de vie doivent être retournés à Symbol pour recyclage. Pour de plus amples informations sur le retour de produits, consultez : http://www.symbol.com/environmental_compliance.

Italiano: per i clienti dell'UE: tutti i prodotti che sono giunti al termine del rispettivo ciclo di vita devono essere restituiti a Symbol al fine di consentirne il riciclaggio. Per informazioni sulle modalità di restituzione, visitare il seguente sito Web: http://www.symbol.com/environmental_compliance.

Latviešu: ES klientiem: visi produkti pēc to kalpošanas mūža beigām ir jānogādā atpakaļ Symbol otrreizējai pārstrādei. Lai iegūtu informāciju par produktu nogādāšanu Symbol, lūdzu, skatiet: http://www.symbol.com/environmental_compliance.

Lietuvių: ES vartotojams: visi gaminiai, pasibaigus jų eksploatacijos laikui, turi būti grąžinti utilizuoti į kompaniją „Symbol“. Daugiau informacijos, kaip grąžinti gaminį, rasite: http://www.symbol.com/environmental_compliance.

Magyar: Az EU-ban vásárlóknak: Minden tönkrement terméket a Symbol vállalathoz kell eljuttatni újrahasznosítás céljából. A termék visszajuttatásának módjával kapcsolatos tudnivalókért látogasson el a http://www.symbol.com/environmental_compliance weboldalra

Malti: Għal klijenti fl-EU: il-prodotti kollha li jkunu waslu fl-aħħar tal-hajja ta' l-użu tagħhom, iridu jiġu rritornati għand Symbol għar-riċiklaġġ. Għal aktar tagħrif dwar kif għandek tiritorna l-prodott, jekk jogħġbok żur: http://www.symbol.com/environmental_compliance.

Nederlands: Voor klanten in de EU: alle producten dienen aan het einde van hun levensduur naar Symbol te worden teruggezonden voor recycling. Raadpleeg http://www.symbol.com/environmental_compliance voor meer informatie over het terugzenden van producten.

Polski: Klienci z obszaru Unii Europejskiej: Produkty wycofane z eksploatacji należy zwrócić do firmy Symbol w celu ich utylizacji. Informacje na temat zwrotu produktów znajdują się na stronie internetowej http://www.symbol.com/environmental_compliance.

Português: Para clientes da UE: todos os produtos no fim de vida devem ser devolvidos à Symbol para reciclagem. Para obter informações sobre como devolver o produto, visite: http://www.symbol.com/environmental_compliance.

Slovenski: Za kupce v EU: vsi izdelki se morajo po poteku življenjske dobe vrniti podjetju Symbol za reciklažo. Za informacije o vračilu izdelka obiščite: http://www.symbol.com/environmental_compliance.

Slovenščina: Pre zákazníkov z krajín EU: Všetky výrobky musia byť po uplynutí doby ich životnosti vrátené spoločnosti Symbol na recykláciu. Bližšie informácie o vrátení výrobkov nájdete na: http://www.symbol.com/environmental_compliance.

Suomi: Asiakkaat Euroopan unionin alueella: Kaikki tuotteet on palautettava kierrätettäväksi Symbol-yhtiöön, kun tuotetta ei enää käytetä. Lisätietoja tuotteen palauttamisesta on osoitteessa http://www.symbol.com/environmental_compliance.

臺灣

低功率電波輻射性電機管理辦法

第十二條

經型式認證合格之低功率射頻電機，非經許可，公司、商號或使用者均不得擅自變更頻率、加大功率或變更原設計之特性及功能。

第十四條

低功率射頻電機之使用不得影響飛航安全及干擾合法通信；經發現有干擾現象時，應立即停用，並改善至無干擾時方得繼續使用。

前項合法通信，指依電信規定作業之無線電通信。

低功率射頻電機須忍受合法通信或工業、科學及醫療用電波輻射性電機設備之干擾。

限制頻率範圍是：2.400 - 2.4835 GHz。 最大發射功率：27dBm

5.250 - 5.350 GHz。 最大發射功率：17dBm

5.725 - 5.850 GHz。 最大發射功率：24dBm

2.4GHz：11個通道

5GHz：8個通道

6 Motorola's Enterprise Mobility Support Center

If you have a problem with your equipment, contact Enterprise Mobility support for your region. Contact information is available at: <http://support.symbol.com/support/>.

When contacting Enterprise Mobility support, please provide the following information:

- Serial number of the unit
- Model number or product name
- Software type and version number

Motorola responds to calls by email, telephone or fax within the time limits set forth in support agreements. If you purchased your Enterprise Mobility business product from a Motorola business partner, contact that business partner for support.

Customer Support Web Sites

Motorola's Support Central Web site, located at <http://support.symbol.com/support/> provides information and online assistance including developer tools, software downloads, product manuals and online repair requests.

Manuals

<http://support.symbol.com/support/product/manuals.do>

General Information

Obtain additional information by contacting Motorola at:

Telephone (North America): 1-800-722-6234

Telephone (International): +1-631-738-5200

Website: <http://www.motorola.com>

MOTOROLA INC
1303 E. ALGONQUIN ROAD
SCHAUMBURG, IL 60196
<http://www.motorola.com>



72-109210-01 Revision A
April 2008